

# Controlling Ground Squirrel Damage to Forages and Field Crops, Ditches, and Dams

F. C. Rulofson, P. Test, and W.D. Edge

Ground squirrels are a major wildlife pest in central and eastern Oregon. They consume substantial amounts of forage and field crops, and their burrow systems can damage ditches, dams, and farm equipment. The degree of damage depends on the kind and density of ground squirrels, the crops present, geographical location, weather, and other environmental conditions.

The two species of ground squirrels that may cause severe damage to live-stock forage, field crops, ditches, and dams in eastern and central Oregon are the Belding's (*Spermophilus beldingi*) and Columbian (*S. columbianus*) ground squirrels. Three other species may cause problems in the area: the Townsend's (*S. townsendii*), California (*S. beecheyi*), and Washington (*S. washingtoni*) ground squirrels. Belding's and Columbian ground squirrels live in large colonies.

Populations increase not dramatically but steadily over several years, reaching 100 or more per acre depending on species and habitat suitability.

Belding's ground squirrel occurs throughout Oregon east of the Cascade Mountains; the Columbian ground squirrel is found in northeastern Oregon. Where their ranges overlap, the two species are easy to distinguish: Belding's ground squirrel is 10 inches long and has a wide band of brown-gray down its back, contrasting with grayish sides; the Columbian ground squirrel is half again as long (15 inches) as Belding's and has a mottled gray back.

## Life History

The annual life cycle for both squirrels is similar. They emerge from hibernation from mid-January to late-February, as soon as the ground thaws and most of the

snow cover is gone. Males emerge 2-3 weeks before females to establish breeding territories. Five to eight young are born 3½ weeks after the female breeds (Table 1). The young are weaned 3 weeks later and appear above ground for the first time in late March to mid-May.

Adults use fat reserves all winter long and during the short breeding season, and don't feed until February or March, when they begin a furious eating binge to replenish fat reserves. They stop eating in late June to mid-July and hibernate until the following February. Young ground squirrels also eat voraciously, and they begin hibernation in late July to early August. Some squirrels may reappear briefly in the fall before winter hibernation.

Adult ground squirrels usually restrict their movements to an area within a 200-foot radius of the burrow. The young of the year initially feed close to the burrow system of their mother, and later disperse. Recorded dispersal distances have exceeded 1 mile.

## Damage

Ground squirrels begin to damage crops as soon as "green-up" occurs in spring. Crop damage is caused primarily by squirrels eating the above-ground parts or by covering the crops with mounds of

*Franz C. Rulofson, Extension agent, Deschutes County; Peter Test, Extension agent, Grant County; and W. Daniel Edge, Extension wildlife specialist; Oregon State University.*

**Table 1. Reproductive characteristics and breeding seasons of ground squirrel species in Oregon.**

| Species                    | Number of litters | Litter size |       | Reproductive season |
|----------------------------|-------------------|-------------|-------|---------------------|
|                            |                   | Mean        | Range |                     |
| Townsend's ground squirrel | 1                 | 8.6         | 4-16  | February-March      |
| Washington ground squirrel | 1                 | 8.0         | 5-11  | February-March      |
| Belding's ground squirrel  | 1                 | 5.9         | 5-9   | February-April      |
| Columbian ground squirrel  | 1                 | 5.8         | 2-7   | March-May           |
| California ground squirrel | 1                 | 7.2         | 4-15  | February-April      |

EC 1429  
June 1993



**OREGON STATE UNIVERSITY EXTENSION SERVICE**

soil from their burrow excavations. These mounds also may damage mowing equipment, and raising mowers to clear mounds reduces the harvestable yield of hay crops. Burrows in irrigated fields often cause water loss, which makes flood irrigation of alfalfa impossible. Burrows may weaken earthen stock dams and levees, causing them to leak or wash away. Burrowing on hilly or mountainous terrain also may accelerate soil erosion by channeling runoff.

Many ranchers suffer significant losses due to ground squirrels. Ground squirrels are a serious pest on rangelands, competing directly with livestock for forage. They also can be a serious pest in pasture land and in some areas cause extensive losses in alfalfa production. The problem is most severe in years of below-normal rainfall, when forage is scarce.

One study showed in a single day 355 Columbian ground squirrels can consume the same amount of forage as 1 cow, and 96 squirrels can consume the same amount as 1 sheep. In northern California, another study reported that, during the growing season, 123 Belding's ground squirrels per acre consumed 1,790 pounds of alfalfa per acre.

Most of the damage to alfalfa occurs before the first cutting. Estimates in Oregon indicate 45% or more of the first cutting of alfalfa may be lost to ground

squirrels. Usually by the time the second cutting is approaching maturity, the squirrels are hibernating and little damage occurs. However, during periods of poor production or cool weather, damage can extend into the second cutting. Thus, the period of damage is fairly short, extending from "green-up" until early to mid-July.

### Management Methods

In the past, flood irrigation flooded ground squirrels' tunnel systems, providing an effective form of control. Now, most irrigation is of the sprinkler system type, which does not flood tunnel systems.

The most effective and economical method of controlling moderate-to-high populations of ground squirrels over large areas is toxic baits. Shooting, trapping, or burrow fumigation may be appropriate for small, isolated populations, or where there is concern for human safety, endangered species, or other nontarget wildlife. However, these methods are more labor intensive, and are unlikely to be cost effective except for high-value crops.

Few rodenticides are available for above-ground control of ground squirrels. Anticoagulants, such as chlorophacinone and diphacinone, are available in several commercially prepared baits. Anticoagulants are effective, but require multiple baitings. Acute toxicants such as zinc phosphide are faster acting and less expensive.

Timing of bait application is critical for effective ground squirrel control. Control should be initiated immediately after the entire population has emerged from hibernation, 2-3 weeks after the first squirrels appear. Food may be scarce at this time because spring growth may not have started, and squirrels will readily accept treated grain baits.

In warmer climates where green forage already is plentiful when the squirrels emerge, cereal baits may be ineffective. In these areas, control is delayed until later in the spring or early summer, when seeds make up much of the squirrels' diet and bait acceptance is improved. During this time, the young feed above ground and the number to be controlled is greater than during the breeding season.

In many areas, adult ground squirrels hibernate in the summer, and in other areas, a summer estivation may occur. In these cases, control is ineffective because much of the population is unavailable to feed on bait.

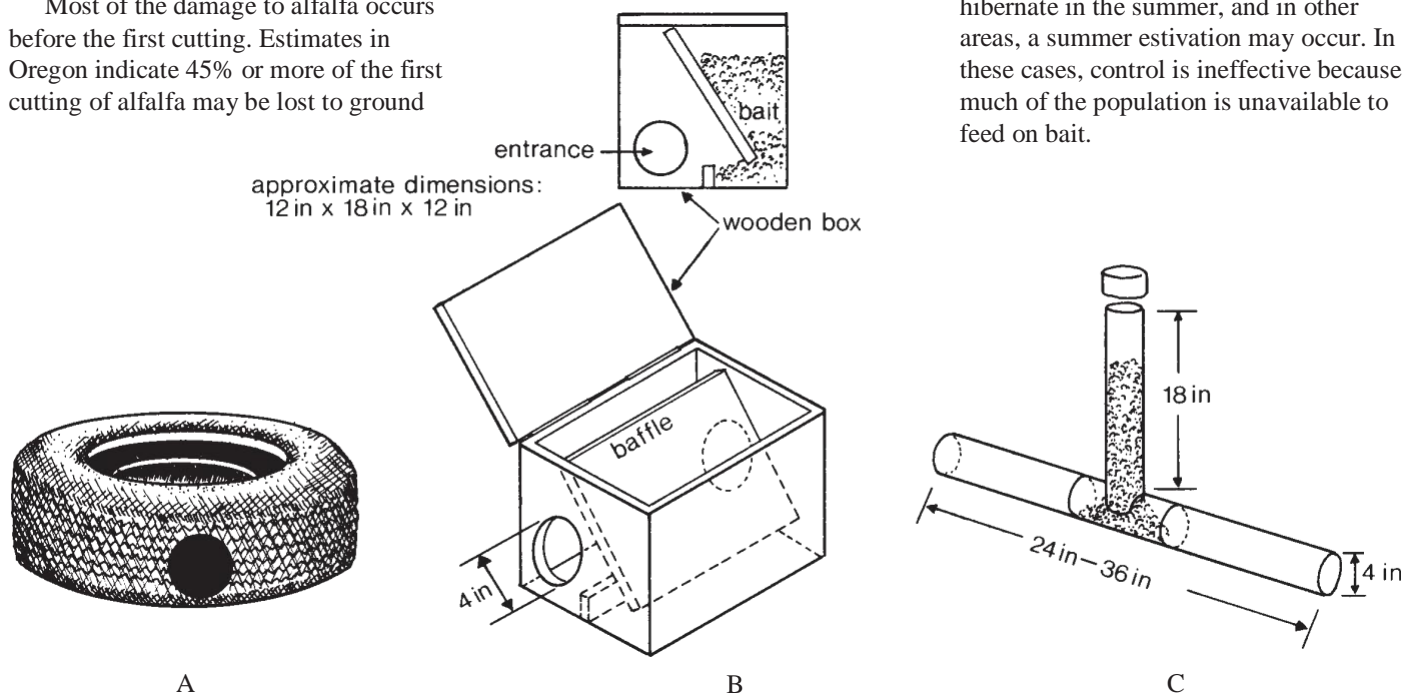

**Figure 1.** Bait stations can prevent exposure of baits to nontarget animals. Tires can be laced shut to prevent rainfall or irrigation water from entering the tire and soaking the bait (A). You can build a simple ground squirrel bait box from wood (B), or from PVC pipe (C). (Illustrations B and C adapted from *Wildlife Pest Control Around Gardens and Homes*, University of California Cooperative Extension Publication No. 21385, 1984.)

Three methods of poison bait application are available depending upon the rodenticide and crop (check with your OSU Extension agent for **current** information). The methods include broadcast baiting, spotbaiting, and bait stations.

Broadcast baiting is done by aircraft, from the back of a pickup truck, or by hand with a cyclone-type fertilizer spreader. Generally, baits are applied in 30-foot swaths, with a 30-foot interval between swaths. Check your rodenticide labels for application rates.

Spot baiting is done simply by scattering a teaspoon of bait directly behind the squirrel's burrow, or preferably along feeding trails. Spot baiting is used to reduce populations in small acreages, ditch banks, and dams.

Bait stations (24- to 36-inch sections of irrigation pipe, old tires, or other designs, as illustrated) are placed at 100-foot intervals throughout fields and kept supplied with poison baits. Bait stations also are used to reduce populations in small acreages, ditch banks, and dams.

Costs and effectiveness of three poison baiting methods and shooting (Table 2) differ markedly. Broadcast baiting is the cheapest and most effective method, followed by bait stations. Shooting is the costliest, least effective, and most time-consuming method.

Control measures using burrow fumigants such as sodium nitrate, potassium nitrate, and aluminum phosphide can be very effective, but fumigation is much more expensive than baiting. The gas cartridges used most commonly are small cardboard cylinders containing a mixture of ingredients with a fuse inserted. They are ignited, then inserted into the burrow. The burrows are closed tightly first with newspaper and then with sod or soil to keep the toxic gases from escaping.

The best time to use fumigants is in the spring, when soil moisture is sufficient to prevent rapid loss of the gas. The burrows should be checked a week after fumigation, and all opened holes should be retreated. Fumigants will not work effectively in dry or coarse-textured soils. Fumigants are not effective when the animals are hibernating, because their metabolic rate is low and they sometimes construct earth plugs in the burrow to seal themselves in until spring.

**Table 2. Cost and effectiveness of poison baiting and shooting for control of ground squirrels**

| Method         | Application time (hrs/acre) | Cost/acre (\$) | Population reduction (%) |
|----------------|-----------------------------|----------------|--------------------------|
| Broadcast bait | 0.01                        | 7.50           | 75                       |
| Bait station   | 1.0                         | 7.50-15.00*    | 60                       |
| Spot bait      | 1.0                         | 15.00          | 75                       |
| Shooting       | 2.0                         | 20.00          | 5                        |

\* Cost varies with expense of bait station

## Environmental Hazards

Increasing public concern is being expressed about the associated environmental hazards of pesticides. Studies show that even with proper use, some nontarget wildlife are being exposed to pesticides.

Shooting provides no risk to nontarget wildlife, but in areas adjacent to housing, shooting may place humans and pets at risk. In these situations, shooting is unacceptable.

Pesticides pose the greatest risk to nontarget wildlife, but some application methods are less risky than others. Placing bait in covered bait stations reduces nontarget exposure to birds and larger mammals such as deer. Placing bait around burrow systems could expose birds to a concentrated dose of pesticide.

Broadcast baiting does scatter bait over a large area, but it is scattered so thinly that it poses little hazard to birds and larger mammals unless it is readily visible. Judicious use of pesticides, regardless of method of application, greatly reduces the risk to nontarget wildlife.

## Endangered Species Warning

The presence of an endangered or threatened species of plant or animal in the area where you plan to take action—chemical, nonchemical, mechanical, or otherwise—could preclude use of this action. If you are aware of an endangered or threatened species, or its critical habitat, in an area where you plan to take this action, you must contact the U.S. Fish and Wildlife Service for further information before taking the action.

## Use Pesticides Safely!

- Wear protective clothing and safety devices as recommended on the label. Bathe or shower after each use.
- Read the pesticide label—even if you've used the pesticide before. Follow closely the instructions on the label (and any other directions you have).
- Be cautious when you apply pesticides. Know your legal responsibility as a pesticide applicator. You may be liable for injury or damage resulting from pesticide use.

## When is Control Needed?

In pest control, the question often is asked, "Do the costs of anticipated damage justify the known costs of control?" Pesticide costs are so low (\$7.50-\$15.00/acre) that the presence of even a few ground squirrels (20-25/acre) justifies use of control. Control is cheaper when numbers are low than when populations expand.

The extent of squirrel damage to ditches and dams often is hard to diagnose visually; a good rule of thumb is, if you find ground squirrel burrows on dams or ditch banks, try to remove the squirrels before collapse occurs. Burrow building for 2-5 years can lead to collapse.

As one would expect, the number of squirrels per acre and the amount of damage are directly related. To estimate the percentage of first cutting you will lose to squirrels, use this rough rule of thumb: In April, before young emerge, count the ground squirrels per acre you see in 5 minutes and multiply by 0.25. Example: You count 20 squirrels on an acre in 5 minutes. Multiply 20 by 0.25, and you can estimate that the squirrels

will cost you 5% of your crop on first cutting.

Control methods often must be applied every year. Studies in Klamath County indicated that even with maximum control application, significant ground squirrel damage occurred the following year in many alfalfa fields. Migration of squirrels from nearby, untreated lands, and survival of some animals within treated fields can rapidly repopulate a treated field.

If the population is small and concentrated in the field, try shooting, followed by spot baiting. If the population is large and widespread, investigate the potential for flood irrigation. If that isn't feasible, consider broadcast baiting or bait stations.

## Poison Baiting Technique

Carefully read the label of the product you intend to use. Make sure the material can be used to control the specific pest, and can be used in your area or on your crop. Take all the necessary precautions to protect yourself and to avoid accidental poisoning of nontarget wildlife.

*Registration status of pesticides is under constant review by the U.S. Environmental Protection Agency. Registration of some toxicants is canceled and registration of other, new toxicants is granted without much public notice. To be sure, check with your county Extension agent for current legal status of a pesticide you wish to use.*

Once you have chosen the bait, take the following steps to optimize your chances of success. Poor results almost always are the result of failing to follow these rules.

1. Be sure the entire ground squirrel population is active. The first squirrels up in the spring usually are the males. The females appear about 3-4 weeks later; usually the increase in number will be obvious, or you can check by shooting or trapping at least 10 squirrels and checking the ratio of males to females. If it is 1:1, the females probably are active. If other factors are satisfactory, start control as soon as possible after the females appear.
2. When you initiate a control program for an area, plan to do the whole area at one time.
3. Be sure ground squirrels are readily accepting grain. Ground squirrel feeding habits vary with the time of year. Test the squirrels' acceptance of untreated (prebait) grain 3-5 days before using toxic grain. Prebaiting increases acceptance of toxic bait. Use the same bait material for prebaiting and baiting. In the case of oat groats, use good quality *whole* oats; the presence of empty hulls makes it easier to determine whether the squirrels used the bait. If little or no use occurs, do not use the poison. Prebaiting is much cheaper than toxic baits. Taking the time to prebait may save you time and money. Pelletized baits may be unavailable in prebait form.
4. Use fresh bait. Bait that is more than a few months old should not be used. Some baits lose their potency over time, and most decrease in palatability to ground squirrels. This leads to poor bait acceptance.
5. Avoid using any bait-carried poison more than once a year. Too much use, over time, can make the squirrel population bait shy.
6. Proper placement of bait is critical to successful control. Scatter bait adjacent to each active burrow in the amount specified on the label. Do not place it in the burrow, because squirrels usually will cover the bait with soil. If you have squirrels outside the target area, you will achieve the greatest reduction in damage by baiting a 200-foot border outside of crop fields, ditches, and dams, in addition to the area where damage is occurring. This removes squirrels that may migrate into the damaged areas—especially the young from areas that were not poisoned.
7. Destruction of the mounds or burrows also can slow re-invasion, but if not done in conjunction with other management activities, is difficult and expensive.

## For More Information

Record, C.R. 1983. "Franklin, Richardson, Belding's and Columbian ground squirrels." Pages B-133-136 in R.M. Timm, Ed. *Prevention and control of wildlife damage*. Great Plains Agricultural Council, Wildlife Resources Commission, and NE Cooperative Extension Service, Institute of Agriculture and Natural Resources, University of Nebraska, Lincoln.

Sauer, W.C. 1977. "Exclusion cylinders as a means of assessing losses of vegetation due to ground squirrel feeding." Pages 14-21 in W.B. Jackson and R.E. Marsh, Eds. *Test methods for vertebrate pest control and management materials*. ASTM STP 625, American Society for Testing and Materials, Philadelphia, Pennsylvania.

Shaw, W.T. 1921. *Washington's annual losses from ground squirrels*. Washington State College Extension Service Bulletin 69, Pullman. 8pp.

---

This publication replaces Extension Circular 1078, *Controlling Ground Squirrel Damage and Field Crops, Ditches, and Dams*, by David deCalesta, former Extension wildlife specialist, Oregon State University. Leonard Askham, Extension vertebrate specialist, Washington State University, and Thomas Hoffman, state director, U.S. Department of Agriculture Animal Damage Control, provided helpful comments on the manuscript.

---

Extension Service, Oregon State University, Corvallis, O.E. Smith, director. This publication was produced and distributed in furtherance of the Acts of Congress of May 8 and June 30, 1914. Extension work is a cooperative program of Oregon State University, the U.S. Department of Agriculture, and Oregon counties.

---

Oregon State University Extension Service offers educational programs, activities, and materials—*without regard to race, color, national origin, sex, age, or disability*—as required by Title VI of the Civil Rights Act of 1964, Title IX of the Education Amendments of 1972, and Section 504 of the Rehabilitation Act of 1973. Oregon State University Extension Service is an Equal Opportunity Employer.

---

