



Oregon Parks and Recreation Commission

March 18, 2021
Zoom Meeting

Draft Agenda

Business Meeting: 8:00am

1. Approve agenda.
2. Commission Business.
 - a) The Cove Palisades – Wave Attenuator Contract Award (**Action**)

The services, programs and activities of the Oregon Parks and Recreation Department are covered by the Americans with Disabilities Act (ADA). If you need special accommodations to participate in this meeting, please contact the commission assistant Denise Warburton at (503) 986-0719 or Denise.warburton@oregon.gov at least 72 hours prior to the start of the meeting.

DRAFT

Oregon Parks and Recreation Commission

March 11, 2021

Agenda Item: 2

Action

Topic: The Cove Palisades – Wave Attenuator Contract Award

Presented by: J.R. Collier, Mountain Region Manager

Description:

Staff requests approval for awarding a procurement contract exceeding \$500,000. The contract will be to purchase specialized Wave Attenuators and hardware to be installed at the Cove Palisades Marina. These units are specialized pieces that are designed and built for this specific location and as such take a significant amount of time to produce. Staff are recommending proceeding with this project award as we are experiencing an ever-increasing amount of damage within the marina due to wave action from weather events and/or an increase in large wake boats traversing the area. This wave action has caused significant damage and wear on the dock facilities within the marina and staff have even started to see damage to boats moored within the marina from these high wave events. Staff have been in consultation with the Oregon State Marine Board over the last several years regarding this issue as well and they had recommended installation of No Wake buoys 200 feet out from our facilities and installing some sort of wave breaker or attenuator floats similar to what we are proposing.

This procurement will include the following:

- 14 Sections of 36-inch diameter HDPE Wave Attenuators
- 10 Sections of 24-inch diameter HDPE Wave Attenuators
- Light Stands for attachment to Attenuators
- Hardware and Accessories for Attenuator Attachments
- Delivery and Off-Loading of units on-site at the Cove Palisades

Preliminary estimates for this project ranged to \$450,000. Upon completing the procurement process, OPRD had one qualified bidder from a fabrication company and that bid came in at \$605,000. This project will be funded via FIP Funds.

Attachments: #1-Bid Documents regarding Wave Attenuator Project

-Page 15 details cost breakdown.

-Page 31 details design and arrangement

Prior Action by Commission: None

Action Requested: Approval to Award Contract

Prepared by: J.R. Collier

Invitation to Bid (ITB)
OPRD - Agency - OREGON DEPARTMENT OF
PARKS AND RECREATION
Purchase of Wave Attenuators
Only Manual Bids Allowed
Opportunity #: OPRD-3074-21



OPRD - Agency - OREGON DEPARTMENT OF
PARKS AND RECREATION
Oregon Parks and Recreation
725 Summer Street NE Suite C
Salem, OR 97301

Contact Melody Waight
Phone 1 (503) 713-1506
Fax

Issued For
OPRD - Agency - OREGON DEPARTMENT OF
PARKS AND RECREATION
Oregon Parks and Recreation
725 Summer Street NE Suite C
Salem, OR 97301

Opportunity #
OPRD-3074-21
Publish Date & Time
02/22/2021 10:32 AM
Closing Date & Time
03/02/2021 11:00:00 AM
Time Zone
Pacific Time

All dates are mm/dd/yyyy

Attachments Exist
Organization Attachments Do Not Exist
Documents for Purchase Do Not Exist

Company Name Pacific Netting Products Inc
Address 25993 United RD NE
City Kingston State WA Zip Code 98346
Contact Name Dave Erickson
Phone 360-297-0858 Fax 360-297-0878
Email Dave@pacificnettingproducts.com
FID (Federal Business Number)
Resident Bidder Yes No FID 91-185-4938
(Do not enter SSN)

Opportunity Summary

PURPOSE AND SCOPE

The Oregon Parks and Recreation Department (OPRD) is seeking bids for the purchase of wave attenuators and, if budget allows, installation services at The Cove Palisades State Park Marina.

As a result of this solicitation process, OPRD intends to award one contract for the goods described in this Solicitation Document. The awarded contract will be in the form of a standard State of Oregon purchase order. The general provisions of the awarded contract(s) are included in Attachment 4 (Standard Terms and Conditions for the Purchase of Goods).

Unless OPRD specifies otherwise, the selected contractor is required to meet the highest standards prevalent in the industry or business most closely involved in providing the appropriate goods or services.

Deadline for questions, clarifications, or protests is 2/25/2021 at 5:00 PM (PT)
ITB Closes 3/2/2021 at 11:00 AM (PT)

Item #	Quantity	Description	Unit Price	Total Amount
1	1 Lump Sum	Commodity No. 120-35 Wave Attenuators for placement at marina.	Lump Sum	\$1,039,766.00

Delivery Requirements By June 30, 2021 Payment Terms Net 30 Payment Term Comments FOB FOB Destination Delivery Comments	Total Including all charges US Dollars Only
---	--

OREGON PARKS AND RECREATION DEPARTMENT



ISSUES THIS INVITATION TO BID

FOR THE PURCHASE OF

WAVE ATTENUATORS

FOR THE COVE PALISADES STATE PARK MARINA

OPRD ITB No. 8873

ORPIN Opportunity No. OPRD-3074-21

BID CLOSING: 3/2/2021 at 11:00 AM

TABLE OF CONTENTS

1.0 PROCUREMENT DESCRIPTION

- 1.1 Purpose and Scope
- 1.2 Specifications
- 1.3 Additional Information

2.0 SOLICITATION PROCESS

- 2.1 Procurement Authority and Method
- 2.2 General Definitions
- 2.3 Procurement Schedule
- 2.4 Public Notice
- 2.5 RESERVED
- 2.6 Inquiries and Changes
- 2.7 Bid Requirements
- 2.8 Bid Opening

3.0 EVALUATION PROCESS

- 3.1 Clarification of Bids
- 3.2 Disqualification of Bids
- 3.3 Cancellation of Solicitation
- 3.4 Administrative Review
- 3.5 Specifications; Minimum Requirements
- 3.6 Pricing
- 3.7 Method of Award
- 3.8 Applicable Preferences
- 3.9 Bidder References
- 3.10 Bidder Responsibility

4.0 AWARD PROCESS

- 4.1 Method of Award
- 4.2 Intent to Award
- 4.3 Protest of Award
- 4.4 Contract Requirements

5.0 BIDDERS CHECKLIST

ATTACHMENTS:

- Attachment 1 Bidder Information and Certification Form
- Attachment 2 Pricing Proposal Form
- Attachment 3 Detailed Specifications
- Attachment 4 Standard Terms and Conditions for the Purchase of Goods
- Attachment 5 Insurance Requirements
- Attachment 6 References
- Attachment 7 Or Equal Form

1.0 PROCUREMENT DESCRIPTION

1.1 PURPOSE AND SCOPE

The Oregon Parks and Recreation Department (OPRD) is seeking bids for the purchase of wave attenuators for use at The Cove Palisades State Park Marina.

As a result of this solicitation process, OPRD intends to award one contract for the goods described in this Solicitation Document. The awarded contract will be in the form of a standard State of Oregon purchase order. The general provisions of the awarded contract(s) are included in **Attachment 4 (Standard Terms and Conditions for the Purchase of Goods)**.

Unless OPRD specifies otherwise, the selected contractor is required to meet the highest standards prevalent in the industry or business most closely involved in providing the appropriate goods or services.

1.2 SPECIFICATIONS

Detailed specifications and requirements for the goods are described in **Attachment 3 (Detailed Specifications)**.

For "Or Equal" requests, see **section 2.6.4**.

1.3 ADDITIONAL INFORMATION

- 1.3.1 Tobacco Free Properties.** Bidders need to be aware that Executive Order 12-13 established statewide policy that properties wholly owned or leased by the State of Oregon shall be tobacco free. If Bidder is selected for contract award, Bidder, and its employees, agents and subcontractors will be expected to comply with established smoking restrictions while performing services on State property.

2.0 SOLICITATION PROCESS

2.1 PROCUREMENT AUTHORITY AND METHOD

OPRD is conducting this Procurement under the authority granted in ORS 279A.050(6)(d), which gives the State Parks and Recreation Department authority to procure or supervise the procurement of all goods, services, public improvements and personal services relating to state parks in accordance with the Public Contracting Code.

OPRD is conducting this Procurement in accordance with OAR 137-047-0255, Competitive Sealed Bidding.

2.2 GENERAL DEFINITIONS

Capitalized terms in the Solicitation Document have the meaning set forth below, and if not defined below, the meaning set forth in the Attorney General's Model Public Contract Rules (OAR Chapter 137), and if not defined there, the meaning set forth in the Public Contracting Code (ORS Chapters 279A, 279B and 279C). Other capitalized terms may be defined in the section in which they appear.

- 2.2.1 "Addendum" or "Addenda"** means an addition to, deletion from, a material change in, or general interest explanation of this Solicitation Document.
- 2.2.2 "Bid" or "Offer"** means the Bidder's written offer submitted in response to this Invitation to Bid, including all necessary attachments.

- 2.2.3 **“Bidder”** or **“Offeror”** means a Person that submits a Bid in response to this Invitation to Bid.
- 2.2.4 **“Closing”** means the date and time specified in this Solicitation Document as the deadline for submitting Bids.
- 2.2.5 **“Contractor”** means the Person with whom OPRD enters into a contract pursuant to this Invitation to Bid.
- 2.2.6 **“Goods”** means all supplies, equipment, materials, and personal property, including any tangible, intangible and intellectual property and rights and licenses in relation thereto, required to be delivered under the Contract resulting from this Solicitation Document.
- 2.2.7 **“OPRD”** means the Oregon Parks and Recreation Department.
- 2.2.8 **“Person”** means any of the following with legal capacity to enter into a Contract: individual, corporation, business trust, estate, trust, partnership, limited liability company, association, joint venture, governmental agency, public corporation or any other legal or commercial entity.
- 2.2.9 **“Responsive”** means having the characteristic of substantial compliance in all material respects with the applicable requirements of this Solicitation Document.
- 2.2.10 **“Services”** means all work required to be performed under the Contract resulting from this Solicitation Document.
- 2.2.11 **“Solicitation Document”** or **“Invitation to Bid (ITB)”** means this document, and all its attachments, which is issued to invite offers from prospective contractors pursuant to ORS Chapter 279B.

2.3 PROCUREMENT SCHEDULE

The anticipated procurement schedule is listed below. All dates are estimates and all times are Pacific Time. OPRD may modify the schedule at its sole discretion.

	<u>DATE</u>	<u>TIME</u>
Solicitation Issued/Posted on ORPIN	2/22/2021	
Deadline for Inquiries (Protests and Requests for Clarification).....	2/25/2021	5:00 PM
Closing/Bids Due/Opening	3/2/2021	11:00 AM (PT)
Contract Awarded	3/5/2021	

2.4 PUBLIC NOTICE

In accordance with OAR 137-047-0300, this Solicitation Document, including attachments and any Addenda issued, is published on the Oregon Procurement Information Network (“ORPIN”) at <http://orpin.oregon.gov>

Bidders should check ORPIN regularly up until Closing for any changes to the Solicitation Document. OPRD is not responsible for any errors or omissions from downloading the Solicitation Document and any attachments.

Bidders who do not have access to ORPIN may request copies from the Single Point of Contact listed in **section 2.6.1** or may request to review the Solicitation Document at the Oregon Parks and Recreation Department headquarters office located at 725 Summer Street NE, Suite C, Salem, Oregon.

2.5 RESERVED

2.6 INQUIRIES AND CHANGES

2.6.1 Single Point of Contact. Bidders shall address ALL INQUIRIES related to this Solicitation to the individual identified below by any of the following methods:

NAME: **Melody Waight, Sr. Procurement Specialist**
 EMAIL: **melody.waight@oregon.gov**
 PHONE: **503-713-1506**
 MAIL: **OREGON PARKS AND RECREATION DEPARTMENT**
725 SUMMER STREET NE, SUITE C, SALEM OR 97301

2.6.2 Requests for Clarification. A prospective Bidder may request clarification of any provision contained in this Solicitation Document. Any request for clarification **must**:

- Be submitted **in writing via e-mail** to the Single Point of Contact, and
- Be received by the deadline for inquiries designated in **section 2.3** Procurement Schedule, or as changed by Addenda.

At its sole discretion, OPRD will respond to such requests received by direct response to the requestor, by issuing clarification(s) in the form of Questions and Answers posted on ORPIN, or by issuing changes in the form of Addenda posted on ORPIN. OPRD's clarification to a Bidder's request, whether orally or in writing, does not change this Solicitation Document and is not binding on OPRD unless the Solicitation Document is amended by Addendum in accordance with **section 2.6.5** below.

2.6.3 Protests of Procurement Process or Solicitation Document. A prospective Bidder who believes that this procurement process is contrary to law or that this Solicitation Document is unnecessarily restrictive, legally flawed, or improperly specifies a brand name may protest the procurement process or Solicitation Document in accordance with OAR 137-047-0730. Any protest **must**:

- Be submitted **in writing (via e-mail)** to the Single Point of Contact,
- Be received by the deadline for inquiries designated in **section 2.3** Procurement Schedule, or as changed by Addenda,
- Describe how the procurement process is contrary to law or the Solicitation Document is unnecessarily restrictive, legally flawed, or improperly specifies a brand name, and
- Describe the desired changes that will remedy the conditions upon which the protest is based.

OPRD will consider such protests received and issue a written response in accordance with OAR 137-047-0730. OPRD's response to a protest does not change this Solicitation Document and is not binding on OPRD unless the Solicitation Document is amended by Addendum in accordance with **section 2.6.5** below.

2.6.4 Requests for "Or Equal" Product. A prospective Bidder may request approval of a manufacturer/brand as an "Or Equal" of the manufacturer/brand specified in this Solicitation Document. Any request for brand approval **must**:

- Be submitted with Bidders Bid response by the Closing date listed in Section 2.3 and must include all relevant information as shown on the Or Equal Form, Attachment 7 concerning how the requested brand meets or exceeds the specifications of the brand specified in this Solicitation Document.

OPRD will review requests for “or equal” submitted in accordance with this section and, at its sole discretion, will determine whether the requested brand is approved or not. OPRD will respond to the requestor with its determination in a timely manner.

2.6.5 Changes to Solicitation Document. Changes to the Solicitation Document will be made only by Addenda issued by OPRD and posted on ORPIN.

2.6.6 Protest of Addendum. A prospective Bidder may submit a protest of the Addendum by the close of the next business day after the issuance of the Addendum, or no later than the due date for Protests of ITB identified in Section 2.3 of this ITB, whichever is later. Unless otherwise specified in the Addendum, a protest must be submitted in the same manner as a protest of the ITB under Section 2.6.3.

2.7 BID REQUIREMENTS

2.7.1 Bid Format

Bids must be submitted on the forms and in the format required by this Solicitation Document. Any specific forms required for Bid submittal are included as attachments to this Solicitation Document.

2.7.2 Bid Content

The Bid must be complete in all respects, including necessary signatures, certifications, documentation, and responses to any other information required by this Solicitation Document, including but not limited to the following:

A. Bidder Information and Certification Form

The Bid must contain a completed **Bidder Information and Certification Form (Attachment 1) including an original or electronic signature** of the Bidder or a representative of the Bidder who is authorized to commit the Bidder to legal contracts. The person signing the Bid shall initial any alterations or erasures in ink. By submitting its Bid, a Bidder agrees to be bound by the terms and conditions contained in this Solicitation Document. A Bidder shall **not** make a Bid conditional upon OPRD’s acceptance of terms or conditions that conflict with or are in addition to those contained in this Solicitation Document.

B. Pricing Proposal

The Bid must contain a **completed Pricing Proposal Form (Attachment 2)**. All Pricing Proposals must be valid for 30 days from Closing.

C. Specifications; Minimum Requirements

The Bid must comply with all specifications and minimum requirements described in **Attachment 3 (Detailed Specifications)**.

D. References

The Bid must include a **Bidder Reference Form (Attachment 6)** and must contain three (3) references including valid contact information for each, from separate firms or clients that may be contacted to verify Bidder’s abilities and experience with respect to goods and/or services provided within the past ten (10) years that are similar in size and scope to those described in this Solicitation Document. References from Oregon Parks and Recreation Department will not be accepted.

E. Welder Qualifications / Certifications

The Bid must include the names and certifications of Bidder's welder(s) it intends to use in the manufacture of the wave attenuators as described in the **Detailed Specifications (Attachment 3)**.

2.7.3 Bid Submission

Bidder is solely responsible for ensuring its Bid is received by the SPC before Closing. OPRD is not responsible for any delays in mail or by common carriers, or for any mis-delivery for any reason, including electronic transmission error.

A Bid submitted by any means not authorized below may be rejected. The following delivery options are permitted for this ITB:

A. Delivery in Person. A Bid may be hand-delivered. A Bid submitted in this manner MUST:

- be delivered to the attention of the SPC at the address on the Cover Page and received prior to Closing;
- be submitted in a sealed envelope, package or box; and
- be clearly labeled on the outside of the sealed submission with Bidder's name and the Bid number.

Hand-delivered Bids will be accepted, one hour prior to Closing or during OPRD's front desk COVID business hours of 8:00 a.m. to 5:00 p.m. Pacific Time, Mondays, Wednesdays, and Fridays, except during State of Oregon holidays.

B. Delivery through Mail or Parcel Carrier. A Bid may be submitted through the U. S. mail or via parcel carrier. A Bid submitted in this manner MUST:

- be sent to the attention of the SPC at the address listed on the Cover Page and received prior to Closing;
- be submitted in a sealed envelope, package or box; and
- be clearly labeled on the outside of the sealed submission with Bidder's name and the ITB number.

C. Delivery by Email. A Bid may be submitted by email. A Bid submitted in this manner MUST:

- be submitted to Contract.OPRD@oregon.gov and received prior to Closing, and
- identify the ITB number in the email subject line.

Attached files must be in PDF format or file formats compatible with MS Office 10 applications. Files may not be in .zip, .exe or .com format. The combined size of all attachments may not exceed 20 Megabytes. Multiple emails may be submitted such that no single email contains attachments that exceed 20 Megabytes combined.

D. Unacceptable Delivery and Receipt. OPRD will **not** accept or consider Bids that are:

- Submitted orally, by FAX, the World Wide Web, or some other Internet protocol;
- Received at a physical location other than the address specified in **section 2.6.1** Single Point of Contact; or
- Received after the Closing.

2.7.4 Bid Modification. A Bid submitted in response to this Invitation to Bid may be modified, in writing, by the Bidder prior to Closing. Bid modifications submitted must be clearly marked as a modification and must comply with all Bid requirements in **section 2.7**. Bidder shall prepare modifications on Bidder's letterhead. Each Bid modification must be signed by an authorized representative and state that the modifications amend and supersede the identified portions of the Bid.

2.7.5 Bid Withdrawal. A Bid submitted in response to this Invitation to Bid may be withdrawn by the Bidder prior to Closing. To withdraw a Bid, Bidder must submit a written notice on company letterhead signed by an authorized representative to the Single Point of Contact listed in **section 2.6.1**. The written notice may be delivered by mail or in person. If delivered in person, OPRD will require appropriate identification before releasing the Bid.

2.7.6 Bid Costs. All costs associated with preparation, submission, modification and withdrawal of a Bid are the sole responsibility of the Bidder and will not be borne by OPRD.

2.7.7 Public Records; Trade Secrets. This Solicitation Document and one copy of each original Bid received in response to it will be kept by OPRD and made a part of a file or record which shall be open to public inspection. If a Bidder believes that its Bid contains any information that is considered a trade secret under ORS 192.501(2) or otherwise exempt from disclosure under the Oregon Public Records Law, ORS 192.410 through 192.505, each sheet of such information must be marked as follows:

"This data is exempt from disclosure under the Oregon Public Records Law pursuant to ORS 192, and is not to be disclosed except in accordance with the Oregon Public Records Law, ORS 192.410 through 192.505."

Bidders are cautioned that cost information submitted in response to a Solicitation is generally not considered a trade secret under the Oregon Public Records Law. Further, information submitted by a Bidder that is already in the public domain is not protected as a trade secret. Go to: https://www.oregonlegislature.gov/bills_laws/ors/ors192.html for the definition of trade secret and information on what is exempt from disclosure.

OPRD shall not be liable for disclosure or release of any information when authorized or required by law or court order to do so. OPRD shall also be immune from liability for disclosure or release of information under the circumstances set out in ORS 646.473(3).

By submitting a response to this ITB, Bidder grants the State of Oregon a non-exclusive, perpetual, irrevocable, royalty-free, worldwide license for the rights to copy, distribute, display, prepare derivative works of, and transmit the response for the purpose of conducting this procurement and to fulfill obligations under Oregon Public Records Laws.

2.8 BID OPENING

Bids will be opened by the Single Point of Contact at the Closing date and time designated in **section 2.3** Procurement Schedule or as changed by Addendum. Only the names of the Bidders and the total price bid, if applicable, will be made available at time of opening.

3.0 EVALUATION PROCESS

Bids received prior to Closing will be evaluated in accordance with the evaluation process described below and any other applicable rules and statutes, including but not limited to OAR 137-047-0255.

3.1 CLARIFICATION OF BIDS

During the evaluation process, OPRD may request clarification from any Bidder regarding any portion of their Bid. Bidders should remain available during the evaluation period to respond to any such requests for clarification. Bidders should respond to requests for Bid clarification in the format and timeframe required by OPRD. If OPRD is unable to contact or receive a requested clarification from a Bidder, that Bidder's Bid may be rejected according to OPRD's interpretation of the Bid without clarification.

3.2 DISQUALIFICATION OF BIDS

Any attempt by a Bidder to improperly influence the evaluation process will result in the disqualification of that Bidder's Bid from consideration.

3.3 CANCELLATION OF SOLICITATION

Any time during the Solicitation Process, OPRD may cancel this Solicitation or reject any and all Bids in accordance with ORS 279B.100.

3.4 ADMINISTRATIVE REVIEW

Bids will be evaluated for compliance with the Bid requirements identified in **section 2.7**. Bids deemed nonresponsive will be rejected. Bids deemed Responsive will be further evaluated as described in **section 3.5** below.

3.5 SPECIFICATIONS; MINIMUM REQUIREMENTS

Responsive Bids will be evaluated for compliance with the specifications and/or minimum requirements described in **section 2.7.2.C**. Bids deemed nonresponsive to the specifications and/or minimum requirements will be rejected. Bids deemed Responsive to the specifications and/or minimum requirements will be further evaluated as described in **section 3.6** below.

3.6 PRICING

For all Responsive Bids, Pricing submitted in accordance with the requirements described in **section 2.7.2.B** Pricing Proposals will be evaluated to determine the lowest total Bid for the items selected for award.

3.7 METHOD OF AWARD

Only Responsive Bids will be considered for award. Award will be based on the lowest total Bid determined in the Pricing section above.

OPRD reserves the right to award a Contract to the Bidder submitting a Bid with guaranteed delivery of all Goods elected for award by June 30, 2021, regardless of price, so long as the total Bid is within OPRD's budget.

If OPRD awards a Contract, OPRD will award the Contract in accordance with ORS 279B.055(10) and OAR 137-047-0600(4).

3.8 APPLICABLE PREFERENCES

In accordance with ORS 279A.120 and 125, OPRD must:

- (a) Give preference to goods or services that have been manufactured or produced in Oregon if price, fitness, availability and quality are otherwise equal,
- (b) Add a percent increase to the Bid of a nonresident Bidder equal to the percent, if any, of the preference given to the Bidder in the state in which the Bidder resides, and
- (c) Give preference to the procurement of goods manufactured from recycled materials.

For purposes of applying (a) and (b) above, Bidder must identify on the **Bidder Information and Certification Form (Attachment 1)** whether Bidder is a “Resident Bidder” as defined in ORS 279A120(1)(a).

3.9 BIDDER REFERENCES

OPRD may contact any or all of the references provided by Bidder in response to **section 2.7.2.D** to verify Bidder’s qualifications, abilities, and experience. OPRD reserves the right to reject a Bidder if the references fail to support Bidder’s ability to provide the Goods or Services described in this Solicitation Document.

3.10 BIDDER RESPONSIBILITY

In accordance ORS 279B.110, OPRD may contact any references (whether or not provided by Bidder) and request any additional information deemed necessary to determine the Responsibility of the Bidder to provide the Goods or Services.

4.0 AWARD PROCESS

4.1 METHOD OF AWARD

If an award is made, OPRD intends to award a contract to the Bidder submitting the lowest total bid for the Bid items selected for award per Attachment 2 – Pricing Proposal Form.

4.2 INTENT TO AWARD

OPRD will notify all Bidders via Notice on ORPIN of the selected Bidder. This announcement will serve as notice to all Bidders that OPRD intends to award a contract to the selected Bidder subject to the successful negotiation of any negotiable provisions.

4.3 PROTEST OF AWARD

If OPRD receives only one Bid, OPRD may dispense with the intent to award protest period described in this section and proceed with Contract award.

4.3.1 Protest Eligibility. A Bidder may protest OPRD’s intent to award a contract in accordance with OAR 137-047-0740 **if** the Bidder is adversely affected because the Bidder would be eligible to be awarded the Contract in the event that the protest were successful **and** the reason for the protest is that:

- All lower Bids are nonresponsive;
- OPRD has failed to conduct the evaluation of Bids in accordance with the criteria or processes described in the solicitation materials;
- OPRD has abused its discretion in rejecting the protestor’s Bid as nonresponsive; **or**
- OPRD’s evaluation of Bids or OPRD’s subsequent determination of award is otherwise in violation of ORS chapter 279B or ORS chapter 279A.

A Bidder’s protest must be submitted to OPRD in writing and must specify the grounds for the protest in order to be considered by OPRD.

4.3.2 Protest Submission. The written protest must be received at the delivery address identified in **section 2.6.1** within three (3) calendar days of OPRD’s Notice of Intent to Award. The protest **MUST** be marked PROTEST and **MUST** identify the Solicitation number.

4.3.3 Response to Protest. OPRD will consider any protest received by the deadline and respond in writing in a timely manner.

4.4 CONTRACT REQUIREMENTS

4.4.1 Contract Form. The Bid is an offer to enter into a contract that, if accepted for award, binds the Bidder to a contract and the terms and conditions contained in this Solicitation Document.

The form of contract will be a standard State of Oregon Purchase Order that incorporates the terms and conditions contained in **Attachment 4 (Standard Terms and Conditions for the Purchase of Goods)**.

A Bidder shall not make a Bid contingent upon OPRD’s acceptance of terms or conditions that conflict with or are in addition to those contained in this Solicitation Document. The process for requesting changes to the Contract terms and conditions is described in section 2.6 of this Solicitation Document.

4.4.2 Recyclable Products. Contractors shall use recyclable products to the maximum extent economically feasible in the performance of the contract work set forth in this document.

4.4.3 Insurance. If the selected Bidder uses owned or leased vehicles to deliver Goods (not common carrier), Bidder shall provide to OPRD certificates and additional insured endorsements of the insurance coverages identified in **Attachment 5 (Insurance Requirements)** or as otherwise specified in this Solicitation Document.

5.0 Bidder’s Checklist. The table below is provided for Bidder’s convenience only.

ITEMS TO INCLUDE IN BID	ATTACHMENT No.	Completed and attached to Bid
Bidder Information and Certifications Form	Attachment 1	<input checked="" type="checkbox"/>
Pricing Proposal	Attachment 2	<input checked="" type="checkbox"/>
References (per Attachment 3, Minimum Requirements 3.3.b)	Attachment 6	<input checked="" type="checkbox"/>
Certifications of Bidder’s Welder(s)	See Attachment 3 – Minimum Requirements (3.3.a)	<input checked="" type="checkbox"/>
Attenuator Specifications	See Attachment 3 – Minimum Requirements (3.3.c)	<input checked="" type="checkbox"/>
Approved Equal Form (if submitting an Equal wave attenuator)	Attachment 7	<input type="checkbox"/>

ATTACHMENT 1

BIDDER INFORMATION AND CERTIFICATION

Bidder Name (printed): Pacific Netting Products Inc.

Address: 25993 United RD NE **City, State, Zip:** Kingston WA. 98346

Bid Clarification Contact Person: Dave Erickson **Telephone:** 360-297-0858

Email: Dave@pacificnettingproducts.com

State of Incorporation: Washington **Entity Type:** S Corporation

Oregon Secretary of State Business Registry Number (if required): _____

Federal Employer Identification Number (EIN): 91-185-4938

Any individual signing below hereby certifies he/she is an authorized representative of Bidder and that:

1. Bidder understands and accepts the requirements of this ITB. By submitting a Bid, Bidder agrees to be bound by the Contract terms and conditions in Attachment A , as modified by Addenda, if any.
2. Bidder acknowledges receipt of any and all Addenda to this ITB.
3. If awarded a Contract, Bidder agrees to comply with all provisions of the ITB and meet the performance standards set forth in the Contract.
4. Bidder has no undisclosed liquidated and delinquent debt owed to the State or any department or agency of the State.
5. I have knowledge regarding Bidder's payment of taxes and by signing below I hereby certify, to the best of my knowledge, Bidder is not in violation of any tax laws of the state or a political subdivision of the state, including, without limitation, ORS 305.620 and ORS chapters 316, 317 and 318.
6. Bidder does not discriminate in its employment practices with regard to race, creed, age, religious affiliation, gender, disability, sexual orientation, national origin. When awarding subcontracts, Bidder does not discriminate against any business certified under ORS 200.055 as a disadvantaged business enterprise, a minority-owned business, a woman-owned business, a service-disabled veteran owned business, or an emerging small business. If applicable, Proposer has, or will have prior to contract execution, a written policy and practice, that meets the requirements described in ORS 279A.112, of preventing sexual harassment, sexual assault and discrimination against employees who are members of a protected class. Agency may not enter into a contract with an anticipated contract price of \$150,000 or more with a Proposer that does not certify it has such a policy and practice. See <https://www.oregon.gov/DAS/Procurement/Pages/hb3060.aspx> for additional information and sample policy template.
7. Bidder and Bidder's employees, agents, and subcontractors are not included on:
 - A. the "Specially Designated Nationals and Blocked Persons" list maintained by the Office of Foreign Assets Control of the United States Department of the Treasury found at: <https://www.treasury.gov/ofac/downloads/sdnlist.pdf>, or

B. the government wide exclusions lists in the System for Award Management found at: <https://www.sam.gov/portal/SAM/#1>

8. Bidder certifies to the best of its knowledge, there exists no actual or potential conflict between the business or economic interests of Bidder, its employees, or its agents, on the one hand, and the business or economic interests of the State, on the other hand, arising out of, or relating in any way to, the subject matter of the ITB. If any changes occur with respect to Bidder's status regarding conflict of interest, Bidder shall promptly notify the State in writing.
9. Bidder certifies all contents of the Bid (including any other forms or documentation, if required under this ITB), and this Bid Cover Sheet are truthful and accurate and have been prepared independently from all other Bidders, and without collusion, fraud, or other dishonesty.
10. Bidder understands any statement or representation made in response to this ITB, if determined to be false or fraudulent, a misrepresentation, or inaccurate because of the omission of material information could result in a "claim" {as defined by the Oregon False Claims Act, ORS 180.750(1)}, made under Contract being a "false claim" {ORS 180.750(2)} subject to the Oregon False Claims Act, ORS 180.750 to 180.785, and to any liabilities or penalties associated with the making of a false claim under that Act.
11. Bidder acknowledges these certifications are in addition to any certifications required in the Contract at the time of execution.

Dave Erickson

Authorized Signature

2-28-2021

Date

Dave Erickson - President

(Printed Name and Title)

dave@pacificnettingproducts.com

Email Address

ATTACHMENT 2

PRICING PROPOSAL FORM

Bidders shall list pricing for each item identified below. Unit price includes all costs associated with the manufacturer, handling, and delivery (FOB Destination) of the Wave Attenuators and all associated hardware and appurtenances to the OPRD address listed in the ITB and, if selected for award, all costs associated with the Services including, but not limited to, all labor, travel, materials, equipment and expenses necessary to perform the Services.

OPRD reserves the right to increase or decrease the quantity(ies) of items awarded or to eliminate line items from award, and does not guarantee, and is under no obligation to purchase any Wave Attenuators or related Services.

Wave Attenuators, Components, and Services

Item #	Description	Quantity	Unit	Unit Cost	Total Cost
1	Wave Attenuator: 36-inch diameter, 32.5 SDR HDPE pipe per Specifications Section 3.2	14	50-foot section	\$ 26,368.00	\$ 369,152.00
2	Wave Attenuator: 24-inch diameter 32.5 SDR HDPE pipe per Specifications Section 3.2	10	50-foot section	\$ 15,278.00	\$ 152,780.00
3	Light Stand with light affixed to Wave Attenuator per Specifications Section 3.8.1.a	24	Ea	\$ 415.00	\$ 9,960.00
4	Sign Stand affixed to Wave Attenuator per Specifications Section 3.8.1.b	24	Ea	\$ 1,290.00	\$ 30,960.00
5	Related Hardware and Accessories per Specifications Section 3.8.1.c	1	Lump Sum		\$ 46,869.00
6	Off-loading of Wave Attenuators FOB Destination per Specification Section 3.8.2.a	1	Lump Sum		\$ 27,200.00
7	Installation of Wave Attenuators per Specification Section 3.8.2.b	1	Lump Sum		\$ 402,845.00
TOTAL BID (Lines 1-7)					\$1,039,766.00

DELIVERY DATE

OPRD requires delivery no later than June 30, 2021. OPRD reserves the right to accept Bids providing partial deliveries that occur after June 30, 2021.

Date all Goods will be delivered to OPRD: Substantial delivery by June 30 OR,

For partial shipments, Insert number of deliveries and delivery dates:

Note: PNP will be able to have a substantial amount of boom sections ready to deliver prior to June 30. All remaining boom sections and materials will be available for delivery on or before July 30. All materials will be located at PNP secured production facility on or before June 30, 2021. Only fabrication labor will be required to complete remaining boom sections after June 30. Note: Concrete anchors would be stored at Hooker Creek Construction Materials - Bend Oregon, until required on site. Can be delivered on or before June 30.

ATTACHMENT 3

DETAILED SPECIFICATIONS

3.0 NEED

The Oregon Parks and Recreation Department (OPRD) wishes to purchase 1,200 feet of wave attenuator comprised of 700 feet of 36-inch SDR 32.5 HDPE and 500 feet of 24-inch SDR 32.5 HDPE, including all related hardware, anchor points, and connections identified in these specifications.

3.1 QUANTITY

OPRD anticipates purchasing 1200 feet of wave attenuator However, OPRD reserves the right to reduce the quantity of wave attenuator purchased if necessary due to budget restraints.

3.2 MATERIAL SPECIFICATIONS

3.2.1 General

- a. Wave Attenuator shall be multi-function wave attenuation boom (“Attenuator”) furnished by Pacific Netting Products, Inc. 25993 United Rd. NE, Kingston, WA. (1.360.297.0858) or Equal.
- b. Each Attenuator section shall be 50-feet in length.
- c. Attenuators shall have a 1-inch thick by 8-inch tall HDPE top splashguard, color Fed Std 13655 Safety Yellow, extending the length of the Attenuator that shall be extrusion welded at 22.5 degrees from top center, built as an integral part of the Attenuator. Manufacturer must provide supporting documents to meet a 20-year minimum life span without color fade.
- d. Attenuator sections shall bolt through the Attenuator end caps to other Attenuator sections using metal steel backing rings and grade 5 or A325 structural bolts.
- e. All steel metal components connecting or anchoring the wave attenuator shall be hot dipped galvanized

3.2.2 36-inch Diameter Attenuator (700 feet total length, all sections)

- a. Attenuator shall be 36-inch diameter, 32.5 SDR HDPE pipe with at least 1-inch thick water tight fusion welded HDPE end caps.
- b. Flanges connecting 36-inch Attenuator section to Attenuator section: Shall be 20, 1-inch A325 structural galvanized bolts.
- c. Attenuator skirt and keel shall be continuous length, built of 12-inch SDR 32.5 HDPE vertical pipes and 18-inch SDR 32.5 HDPE lower ballastable pipes with 1/2-inch thick HDPE rigid sheet with a total skirt/keel depth of 48-inches, permanently welded in-between pipes and to bottom of 36-inch Attenuator. Lower ballast shall be 100lb/ft.

Example of 36-inch Attenuator, skirt, and keel:



3.2.3 24-inch Diameter Attenuator (500 feet total length, all sections)

- a. Attenuator shall be 24-inch diameter 32.5 SDR HDPE pipe with at least 1-inch thick water tight fusion welded HDPE end caps.
- b. Flanges connecting 24-inch Attenuator section to Attenuator section: Shall be connected using 16, 3/4" A325 structural galvanized bolts
- c. Attenuator skirt shall be continuous length; built of heavy duty 4-ply poly-nylon with a depth of 48-inches, adequately bolted to the Attenuator. Keel shall be welded to bottom of 24-inch Attenuator. The skirt shall be resistant to impacts, tearing, and abrasion, flexible and weighted with ballast minimum of 20lbs per foot required.

Example of 24-inch Attenuator and skirt:

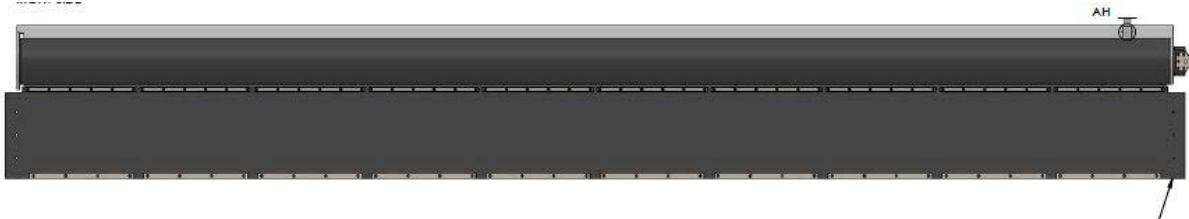

3.2.4 Anchor Points and Connections

- a. **Lake Anchor Points.** Steel anchor points shall be available at Attenuator section ends. Anchor points shall be on both sides at or just below water level; shore and lake anchor design, adequate for securing Attenuator in place.

- b. **Lake Anchor Connections.** Flange bolted assembly shall include steel mooring ring built of 1inch ASTM A572 g50 steel material.

Example of steel mooring ring and lake anchor point (one side of Attenuator):

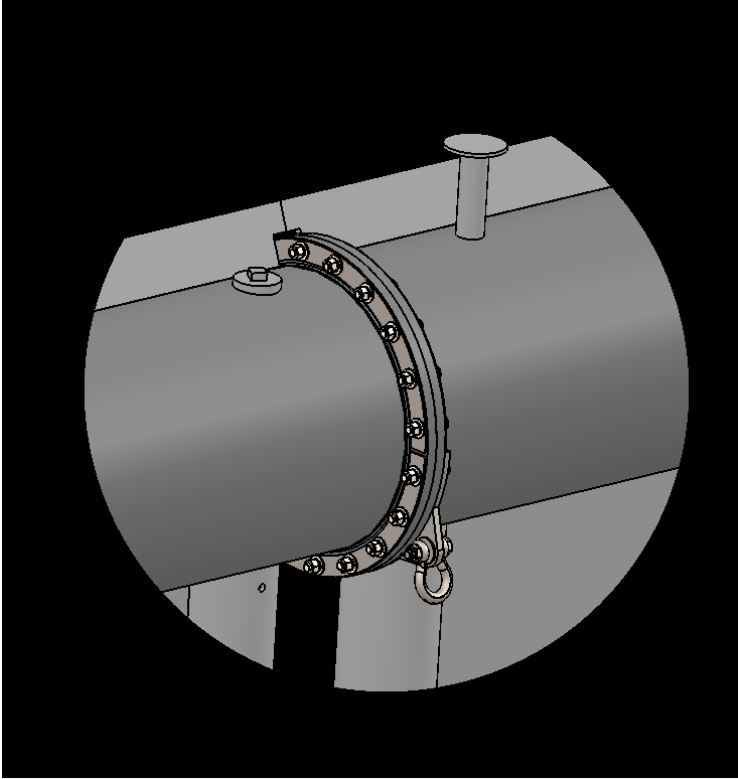

- c. **Shore Anchor Connections.** Shore anchor connections shall include steel end plate with 1-1/4-inch wide mouth mooring pad bolted to HDPE end plate.

Example of and cap and shore anchor plate:

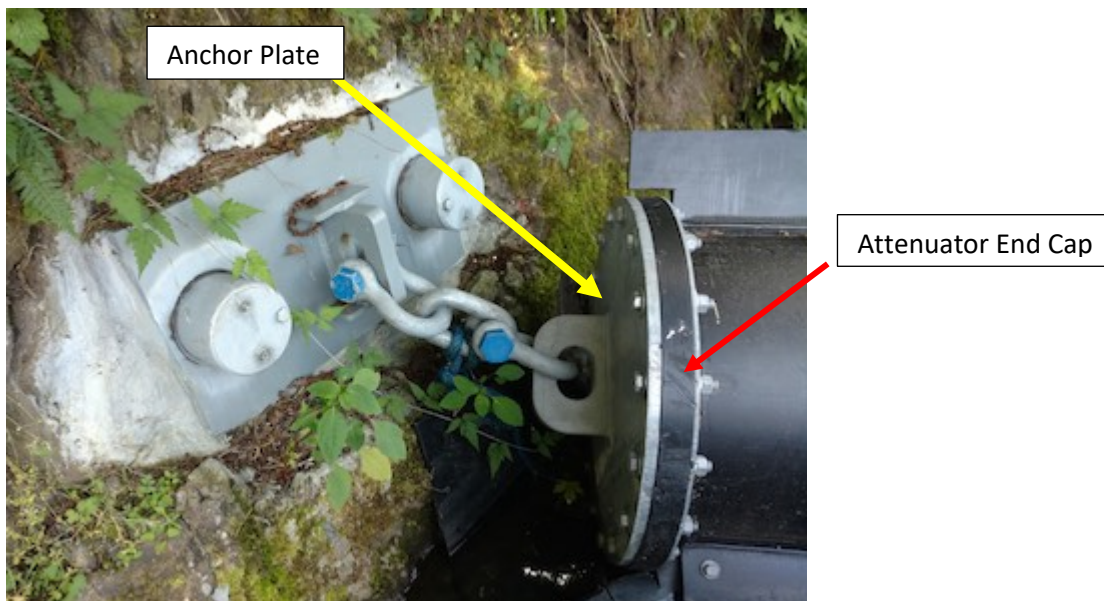

3.2.5 Hardware and Accessories

- a. All metal hardware or accessories shall be galvanized steel.
- b. All nut and bolt hardware shall have locking mechanisms.

3.3 MINIMUM REQUIREMENTS

- a. Bidder shall provide, with its Bid, references from at least three (3) customer's that Bidder provided goods and services most comparable to those requested in this ITB within the last ten years.

References shall include the following:

- Customer / Entity
 - Customer contact name
 - Customer contact telephone number
 - Customer contact email
- b. Bidder shall provide, with its Bid, qualifications and certifications of its welder(s) showing experience and certification for high density polyethylene welding.
 - c. Attenuator Specifications: Bidder shall provide, with its Bid, technical specifications for Attenuator's bid including: materials used, a description of manufacturing method of floating components, structural properties, and Attenuator section connection description and drawings.

If Bidding an "Equal" product, include Attachment 8 Or Equal form with all required technical specifications and information for OPRD to determine if Attenuator is an Equal product.

3.4 PRE-MANUFACTURE SUBMITTALS

Contractor shall provide shop drawings for Attenuator, Attenuator section connections, Attenuation skirts/keel and/or panels and anchor connections including materials lists to OPRD for review prior to fabrication.

3.5 DELIVERY

- a. All materials shall be delivered to The Cove Palisades State Park, Crooked River Day Use Area located at 7300 SW Jordan Rd. Culver, OR 97734 no later than June 30, 2021.

OPRD *may* consider accepting a partial delivery before June 30, 2021 and the remaining Attenuator's after June 30, 2021. Bidder shall state, in its Bid, the earliest date all product will be delivered or, the date(s) Bidder will make deliveries (if multiple dates), keeping in mind it is OPRD's desire to receive as many Attenuator's as possible prior to June 30, 2021.

- b. OPRD desires off-loading and placement services at time of delivery (see Optional Services below).

- c. Goods will be inspected by OPRD for damage upon delivery and off-loading.

3.6 MANUALS / INSTALLATION SUPPORT

- a. Provide installation procedures with delivered Attenuators.
- b. Provide technical installation guidance via phone support during OPRD installation of Attenuators (Note: installation is anticipated to occur during September 2021.)

3.7 WARRANTY

a. Attenuator Warranty.

Provide a 10-year warranty on Attenuators (including all components, hardware, etc. that are attached to, and part of the Attenuator) that warrants Attenuator to be: watertight; corrosion free; rot-resistant; UV-stable, and able to withstand temperatures to 32 degrees below freezing.

b. Attenuator Splash Guard Warranty.

Provide a 20-year minimum warranty for the Attenuator splash guard (see Section 3.2.1(c)) against color fade.

c. General Component Warranty.

Provide any other warranties for parts or equipment not included above that extend beyond a 1-year period.

3.8 OPTIONAL ITEMS AND SERVICES

3.8.1 Sign Stands, Light Stands, Additional Hardware and Connection Components

Bidder shall include, in the space(s) provided on the Pricing sheet (Attachment 2), the cost for the following optional Attenuator components and accessories:

- a. **Light Stand and Light.** Include the cost to affix manufacturer's standard light stand, with light, to Attenuator.
- b. **Sign Stand.** Include the cost to attach manufacturer's standard (safety) sign stand to Attenuator.
- c. **Related Hardware and Accessories.** Include the cost for each miscellaneous piece of hardware and accessories not identified or included as part of the Attenuator. Hardware and Accessories may include, but are not limited to: marine cable, chain, cable thimbles, shackles, cable clamps.

Please provide pictures or drawings of standard light stands and signage materials as affixed to an Attenuator. Include description or picture/drawing of Hardware and Accessories.

3.8.2 Services

Bidder shall include, in the space(s) provided on the Pricing sheet (Attachment 2), the cost for the following Services:

- a. Off-loading and placement of Attenuators in water or alternate location at delivery site.
- b. Cost for installation of Attenuators at The Cove Palisades State Park, Crooked River Day Use Area Marina located at 7300 SW Jordan Rd. Culver, OR 97734. Installation costs shall include all travel, labor, tools, equipment and materials necessary to install the purchased Wave Attenuators, including both lake and shore anchoring. (Note: installation is anticipated to occur during September 2021.)

3.9 PAYMENT

OPRD will make payment as follows:

3.9.1 Cost of Materials. OPRD will make payment for materials purchased for the manufacture of the wave attenuators upon receipt of an invoice from Contractor showing a detailed list of materials purchased and received by Contractor for the manufacture of the 24-inch and 36-inch Attenuators and receipt of Pre-Manufacture Submittals per Attachment 3 – Detailed Specifications section 3.4.

3.9.2. Attenuators. OPRD will make payment for the remaining balance of the awarded Contract price of the 24-inch and 36-inch Attenuators upon delivery and acceptance of the 24-inch and 36-inch Attenuators by OPRD.

3.9.3 Off-Loading. OPRD will make payment for Services (if awarded) to off-load Attenuators at The Cove Palisades State Park Marina upon completion of Services and acceptance by OPRD.

3.9.4 Installation. OPRD will make payment for Installation Services (if awarded) upon completion of Installation Services and acceptance by OPRD.

ATTACHMENT 4

STANDARD TERMS AND CONDITIONS FOR THE PURCHASE OF GOODS

STANDARD TERMS AND CONDITIONS

- 1. DELIVERY:** Deliveries will be F.O.B destination. Contractor shall pay all transportation and handling charges. Contractor is responsible and liable for loss or damage until final inspection and acceptance of the Goods. Contractor remains liable for latent defects, fraud, and warranties.
- 2. INSPECTIONS:** OPRD may inspect and test the Goods and related Services (collectively, Goods). OPRD may reject non-conforming Goods and require Contractor to correct them without charge or deliver them at a reduced price, as negotiated. If Contractor does not cure any defects within a reasonable time, OPRD may reject the Goods and cancel this Purchase Order (PO) in whole or in part. This paragraph does not affect or limit OPRD's rights, including its rights under the Uniform Commercial Code, ORS chapter 72 (UCC).
- 3. GOODS PAYMENT OBLIGATION:** OPRD will pay only for Goods that meet the specifications and performance standards specified in this Solicitation Document. If OPRD determines that any Goods do not meet these specifications or performance standards, OPRD will notify Contractor of OPRD's rejection of the Goods. Upon receipt of notice of non-acceptance, Contractor shall, remove and replace rejected Goods at Contractor's sole expense within 10 calendar days to ensure the Goods meet such specifications or performance standards, and shall notify OPRD in writing that it has completed such modifications or replacements and re-tender them to OPRD.

OPRD will thereafter examine the modified or replaced Goods within 5 business days of receipt of Contractor's delivery. Failure of the Goods to meet the specifications and performance standards after the re-tender following OPRD's initial rejection of the Goods shall constitute a default by Contractor. Upon such default, OPRD may either (i) notify Contractor of such default and instruct Contractor to modify or replace the Goods or (ii) notify Contractor of such default and instruct Contractor to cease work, in which case Contractor shall refund to OPRD all amounts paid by OPRD related to such Goods. Such refund is in addition to, and not in lieu of, any other remedies OPRD may have for Contractor's default.

OPRD will pay Contractor within 30 days from (i) the date the Goods are delivered and accepted, in accordance with the preceding paragraphs, or (ii) the date the invoice is received, whichever is later. If OPRD fails to pay within 45 days of such date, Contractor may assess overdue account charges up to a rate of 2/3% per month (8% APR) or the maximum rate allowed by law on the outstanding balance.

- 4. STATE PAYMENT OF CONTRACTOR CLAIMS:** If Contractor does not pay promptly any claim that is due for Goods or Services furnished to the Contractor by any subcontractor in connection with this PO, the State may pay such claim and charge that payment against any payment due to the Contractor under this PO. The State's payment of a claim does not relieve the Contractor or its surety, if any, from their obligations for any unpaid claims.
- 5. WARRANTIES:** Contractor represents and warrants that the Goods are new, current, and fully warranted by the manufacturer. Delivered Goods will comply with specifications and be free from defects in labor, material and manufacture. All UCC implied and expressed warranties are incorporated in this PO. Contractor shall transfer all warranties to the State.
- 6. TERMINATION:** (i) The parties may terminate this PO by mutual agreement. (ii) OPRD may terminate this PO at any time with written notice to Contractor. Upon receipt of the written notice, Contractor shall stop performance, and OPRD shall pay Contractor for Goods delivered and accepted. (iii) OPRD may terminate this PO at any time if OPRD fails to receive funding, appropriations, or other expenditure authority. (iv) If Contractor breaches any PO provision or is declared insolvent, OPRD may terminate this PO for cause with written notice to Contractor, and Contractor shall be liable for all incidental and consequential damages resulting from its breach, including all damages as provided in the UCC.
- 7. HOLD HARMLESS:** *Contractor shall indemnify, defend and hold harmless the State and its agencies, their divisions, officers, employees, and agents, from all claims, suits or actions of any nature arising out of or related to the activities of Contractor, its officers, subcontractors, agents or employees under this PO.*

- 8. GOVERNING LAW, JURISDICTION, VENUE:** This PO is governed by Oregon law, without resort to any other jurisdiction's laws. Any claim, action, suit, or proceeding between the State and the Contractor that relates to this PO (Claim) must be heard exclusively in the Circuit Court of Marion County for the State of Oregon . If the Claim must be brought in a federal forum, then it must be heard exclusively in the US District Court for the District of Oregon. Contractor consents to the in personam jurisdiction of these courts. *Neither this Section nor any other provision of this PO is a waiver by the State of any form of defense, sovereign immunity, governmental immunity, immunity based on the Eleventh Amendment to the US Constitution, or other immunity, from any Claim or from the jurisdiction of any court.*
- 9. FORCE MAJEURE:** Neither party is responsible for delay or default caused by an event beyond its reasonable control. OPRD may terminate this PO without liability to Contractor upon written notice after determining the delay or default reasonably prevents performance of this PO.
- 10. ASSIGNMENT/SUBCONTRACT/SUCCESSORS:** Contractor shall not assign, transfer, or subcontract rights (Subcontract) or delegate responsibilities under this PO in whole or in part, without the prior written approval of OPRD. This PO's provisions are binding upon and inure to the benefit of the parties to the PO and their respective successors and assigns.
- 11. ACCESS TO RECORDS:** Contractor shall maintain all accounting records relating to this PO according to GAAP and any other records relating to Contractor's performance ("Records") for six (6) years from termination or as otherwise required. Contractor shall grant the State and its agencies, the Secretary of State Audits Division, the federal government, and their duly authorized representatives access to the Records, including reviewing, auditing, copying, and making transcripts.
- 12. COMPLIANCE WITH APPLICABLE LAWS:** Contractor shall comply with all applicable federal, state and local laws, regulations, executive orders, and ordinances, as amended (Rules), including: (i) Titles VI and VII of Civil Rights Act of 1964; (ii) Sections 503 and 504 of the Rehabilitation Act of 1973; (iii) the Americans with Disabilities Act of 1990; (iv) Executive Order 11246; (v) The Age Discrimination in Employment Act of 1967, and the Age Discrimination Act of 1975; (vi) The Vietnam Era Veterans' Readjustment Assistance Act of 1974; (vii) ORS Chapter 659; (viii) ORS 279B.020, , and 279B.270; (ix) all other applicable requirements of federal and state civil rights and rehabilitation statues, rules and regulations; (x) all federal and state laws governing the handling, processing, packaging, storage, labeling, and delivery of food products; and (xi) all regulations and administrative rules established pursuant to the foregoing laws. OPRD's performance is conditioned upon Contractor's compliance with, 279B.220, 279B.225, 279B.230, and 279B.235, as applicable. All applicable Rules are incorporated by reference in this PO.
- 13. WORKERS' COMPENSATION:** Contractor shall comply with ORS 656.017 and provide the required workers' compensation coverage, unless exempt under ORS 656.126(2). Contractor shall ensure that its Subcontractors, if any, comply with these requirements.
- 14. SAFETY AND HEALTH REQUIREMENTS:** Contractor represents and warrants that the Goods comply with all federal and Oregon safety and health requirements.
- 15. SAFETY DATA SHEET (SDS):** Contractor shall provide OPRD with a Safety Data Sheet for any Goods which may release, or otherwise result in exposure to, a hazardous chemical under normal conditions of use (OAR 437- 002-0360 and 29 CFR 1910.1200). Contractor shall label, tag or mark such Goods.
- 16. RECYCLABLE PRODUCTS:** Unless otherwise required, Contractor shall use recycled and recyclable products to the maximum extent economically feasible in the performance of the PO. These products shall include recycled paper, recycled PETE products, other recycled products (ORS 279A.010(1)(gg),(hh),(ii)), and other recycled plastic resin products.
- 17. AMENDMENTS:** All amendments to this PO must be in writing, signed by OPRD.
- 18. SEVERABILITY:** If a court of competent jurisdiction declares any provision of this PO to be invalid, the other provisions and the rights and obligations of the parties remain in effect.
- 19. WAIVER:** OPRD's failure to enforce any provision of this PO is not a waiver or relinquishment by OPRD of its rights to such performance in the future or to enforce any other provisions.
- 20. AWARD TO FOREIGN CONTRACTOR:** If Contractor is not registered to do business or has no office in the State of Oregon, Contractor shall promptly provide to the Oregon Department of Revenue and the Secretary of

State Corporation Division all information required by those agencies relative to this PO. OPRD may withhold final payment under this PO until Contractor has met this requirement.

- 21. TAX CERTIFICATION:** Contractor hereby certifies under penalty of perjury: (a) the number shown on this form is the correct Federal Employer Identification Number; (b) it is not subject to backup withholding because (i) it is exempt from backup withholding, (ii) it has not been notified by the IRS that it is subject to backup withholding as a result of a failure to report all interest or dividends, or (iii) the IRS has notified Contractor that it is no longer subject to backup withholding; and (c) it is not in violation of any Oregon tax laws.
- 22. PREVENTION OF SEXUAL HARASSMENT, SEXUAL ASSAULT, & DISCRIMINATION:** Contractor hereby certifies that it has a written policy and practice that meets the requirements described in HB 3060 (2017), Oregon Laws, chapter 212, for preventing sexual harassment, sexual assault, and discrimination against employees who are members of a protected class and that Contractor shall maintain the policy and practice in force during the entire term of this PO.

ATTACHMENT 5

INSURANCE REQUIREMENTS

1. INSURANCE

Contractor shall obtain at Contractor's expense the insurance specified in this Attachment 5 prior to performing under this Contract and shall maintain it in full force and at its own expense throughout the duration of this Contract, as required by any extended reporting period or tail coverage requirements, and all warranty periods that apply. Contractor shall obtain the following insurance from insurance companies or entities that are authorized to transact the business of insurance and issue coverage in Oregon and that are acceptable to OPRD. Coverage shall be primary and non-contributory with any other insurance and self-insurance, with the exception of Professional Liability and Workers' Compensation. Contractor shall pay for all deductibles, self-insured retention and self-insurance, if any.

1.1 WORKERS' COMPENSATION; EMPLOYERS' LIABILITY

All employers, including Contractor, that employ subject workers, as defined in ORS 656.027, shall comply with ORS 656.017 and provide workers' compensation insurance coverage for those workers, unless they meet the requirement for an exemption under ORS 656.126(2). Contractor shall require and ensure that each of its subcontractors complies with these requirements. If Contractor is a subject employer, as defined in ORS 656.023, Contractor shall also obtain employers' liability insurance coverage with limits not less than **\$500,000** each accident. If Contractor is an employer subject to any other state's workers' compensation law, Contractor shall provide workers' compensation insurance coverage for its employees as required by applicable workers' compensation laws including employers' liability insurance coverage with limits not less than \$500,000 and shall require and ensure that each of its out-of-state subcontractors complies with these requirements.

1.2 COMMERCIAL GENERAL LIABILITY **(Only required if installation services are awarded)**

Commercial General Liability Insurance covering bodily injury, death and property damage in a form and with coverage that is satisfactory to the State. This insurance shall include personal and advertising injury liability, products and completed operations contractual liability coverage for the indemnity provided under this Contract, and have no limitation of coverage to designated premises, project or operation. Coverage shall be written on an occurrence basis in an amount of not less than **\$2,000,000** per occurrence. Annual aggregate limit shall not be less than **\$4,000,000**.

1.3 AUTOMOBILE LIABILITY INSURANCE **(If Services are awarded or if Contractor uses owned vehicles for delivery)**

If, Contractor uses an outside delivery company/motor carrier to deliver the Goods, proof of auto liability or motor carrier cargo liability related to shipment of the Goods will not be required.

If, Contractor will be delivering the Goods using their own truck/vehicle, the following additional required coverages shall include auto liability and motor carrier cargo liability

Automobile Liability Insurance covering Contractor's business-use including coverage for all owned, non-owned, or hired vehicles with a combined single limit of not less than **\$2,000,000** for bodily injury and property damage. This coverage may be written in combination with the Commercial General Liability Insurance (with separate limits for Commercial General Liability and Automobile Liability). Use of personal automobile liability insurance coverage may be acceptable if evidence that the policy includes a business use endorsement is provided.

Motor Truck Cargo Liability Insurance covering loss to cargo in transit during the performance of this contract. This coverage may be written in combination with the Commercial General Liability

Insurance (with separate limits). Combined single limit per occurrence shall not be less than **\$4,000,000**.

2. EXCESS/UMBRELLA INSURANCE

A combination of primary and excess/umbrella insurance may be used to meet the required limits of insurance.

3. ADDITIONAL INSURED (If applicable)

The Commercial General Liability insurance and Automobile liability insurance required under this Contract must include an additional insured endorsement specifying the State of Oregon, its officers, employees and agents as Additional Insureds, including additional insured status with respect to liability arising out of ongoing operations and completed operations, but only with respect to Contractor's activities to be performed under this Contract. Coverage shall be primary and non-contributory with any other insurance and self-insurance. The Additional Insured endorsement with respect to liability arising out of Contractor's ongoing operations must be on ISO Form CG 20 10 07 04 or equivalent and the Additional Insured endorsement with respect to completed operations must be on ISO form CG 20 37 04 13 or equivalent.

4. TAIL COVERAGE

If any of the required insurance is on a claims made basis and does not include an extended reporting period of at least 24 months, Contractor shall maintain either tail coverage or continuous claims made liability coverage, provided the effective date of the continuous claims made coverage is on or before the effective date of this Contract, for a minimum of 24 months following the later of (i) Contractor's completion and OPRD's acceptance of all Services and Goods required under this Contract, or, (ii) OPRD or Contractor termination of Contract, or, iii) The expiration of all warranty periods provided under this Contract.

5. CERTIFICATE(S) AND PROOF OF INSURANCE

Contractor shall provide to the OPRD individual/address below, or as otherwise directed by OPRD, Certificate(s) of Insurance for all required insurance before delivering any Goods and performing any Services required under this Contract. The Certificate(s) shall list the State of Oregon, its officers, employees and agents as a Certificate holder and as an endorsed Additional Insured. If excess/umbrella insurance is used to meet the minimum insurance requirement, the Certificate of Insurance must include a list of all policies that fall under the excess/umbrella insurance. OPRD has the right to request copies of insurance policies and endorsements relating to the insurance requirements in this Contract.

Oregon Parks and Recreation Department

ATTN: Melody Waight, Sr. Procurement Specialist
Procurement Division
725 Summer Street NE, Suite C
Salem, OR 97301

Or by email at:

melody.waight@oregon.gov (preferred method)

6. NOTICE OF CHANGE OR CANCELLATION

Contractor or its insurer must provide at least 30 days' written notice to OPRD before cancellation of, material change to, potential exhaustion of aggregate limits of, or non-renewal of the required insurance coverage(s).

7. INSURANCE REQUIREMENT REVIEW

Contractor agrees to periodic review of insurance requirements by OPRD under this Contract and to provide updated requirements as mutually agreed upon by Contractor and OPRD.

8. OPRD ACCEPTANCE

All insurance providers are subject to OPRD acceptance. If requested by OPRD, Contractor shall provide complete copies of insurance policies, endorsements, self-insurance documents and related insurance documents to OPRD's representatives responsible for verification of the insurance coverages required under this Attachment 5.

ATTACHMENT 6

REFERENCE CHECK FORM

REFERENCES COMPARABLE IN SIZE AND SCOPE: Bidder shall provide a list of three firms or clients who can be contacted regarding the quality of goods and services the Bidder provided within the last ten years.

Reference #1

Name of Firm/Client:	Cove Estates Marina		
Reference Contact Person:	Brett Bickford		
Telephone:	509-669-2308	Email:	brett.bickford@chelanpud.org
Alternate Reference Contact Person:			
Telephone:		Email:	
Description of goods and services (type, size, quantity, location installed): PNP provided layout, anchor design, fabrication for 36" x 500' Class III Multifunction Wave Attenuation System. Inclusive of anchor design, anchor materials fabrication, delivery. Same design as proposed to Oregon State Parks - Cove Palisades Marina			
Were installation services performed? If yes, please describe: Yes, onsite assembly assistance, deployment, oversight			
Total cost of goods or services provided: \$250,000.00			

Reference #2

Name of Firm/Client:	Portland General Electric (PGE)		
Reference Contact Person:	Pat Wilmouth		
Telephone:	503-464-7619	Email:	pat.wilmouth&pgn.com
Alternate Reference Contact Person:			
Telephone:		Email:	
Description of goods and services (type, size, quantity, location installed): PNP provided 1600 feet of 24" class 1 Multifunction Boom with lower rubber skirt, weight bars, anchoring. Same design as provided to Oregon State Parks- Cove Palisades Marina.			
Were installation services performed? If yes, please describe: Yes, PNP performed general contracting roll in design, manufacturing and installation.			
Total cost of goods or services provided: \$1,000,000.00			

"This data is exempt from disclosure under the Oregon Public Records Law pursuant to ORS 192, and is not to be disclosed except in accordance with the Oregon Public Records Law, ORS 192.410 through 192.505."

Reference #3

Name of Firm/Client:	Village of Naksup		
Reference Contact Person:	Cheryl Graham		
Telephone:	250-229-2169	Email:	info@grahammarine.ca
Alternate Reference Contact Person:			
Telephone:		Email:	
Description of goods and services (type, size, quantity, location installed):			
36" x 400' class III Multifunction Wave Attenuation Boom. Same design as proposed to Oregon State Parks - Cove Palisades Marina.			
Were installation services performed? If yes, please describe:			
PNP provided technical oversight during onsite assembly and deployment by others.			
Total cost of goods or services provided:			
\$200,000.00			

"This data is exempt from disclosure under the Oregon Public Records Law pursuant to ORS 192, and is not to be disclosed except in accordance with the Oregon Public Records Law, ORS 192.410 through 192.505."

ATTACHMENT 7 OR EQUAL FORM

We hereby submit for your consideration the following product(s) instead of the specified item(s) Described in the Detailed Technical Specifications, Attachment 3.

Include complete information and detailed specifications for all items proposed as "Equal". Please also provide scale drawing(s) of the proposed substitute item(s). Use additional sheets if necessary.

Proposed Substitution(s):

No Substitutions Provided

Respond to the following:

A. Does the substitution affect dimensions shown in the Detailed Specifications? Yes____No____ If yes, clearly indicate changes.

B. What effect does substitution have on the design, durability and usability?

C. Manufacturer's guarantees/warranty of the proposed and specified items are:

_____ Same _____ Different (explain)

The undersigned certifies that the function, appearance and quality are equivalent or superior to the specified item(s).

Submitted by:

Signature _____ Title _____

Company _____ By _____
Printed Name

Telephone _____ Email _____



Monday, March 1, 2021

Melody Waight
Melody.waight@oregon.gov
Sr. Procurement specialist
Oregon Parks Recreation Department
725 Summer Street NE Suite C, Salem OR 97301

Melody,

Thank you for the opportunity to offer a proposal for the design, manufacturing, and installation of a PNP wave attenuator for the Cove Palisades site. We have reviewed the bid specifications and are confident that we will be able to meet or exceed your expectations for this project. PNP has manufactured several Wave Attenuation Systems that are nearly identical to what you are requesting, all of which are performing well for their intended purpose.

Some of the key factors in wave attenuation effectiveness are the overall mass of the boom to control/dampen its motion; it is also the, depth, of the wall/skirt to reduce wave energy passage. For your site location, we feel that the combination of the 24" and 36" wave attenuation booms will be well suited to greatly reduce wave action that is created by passing boats and wind driven wave action.

General Arrangement: This image (figure 1) below shows the general arrangement as we understand it for this wave attenuator. Three sections, with a combined length of 1200 feet. Final alignment/configuration would certainly be a part of the design phase of the project if we are to be selected.

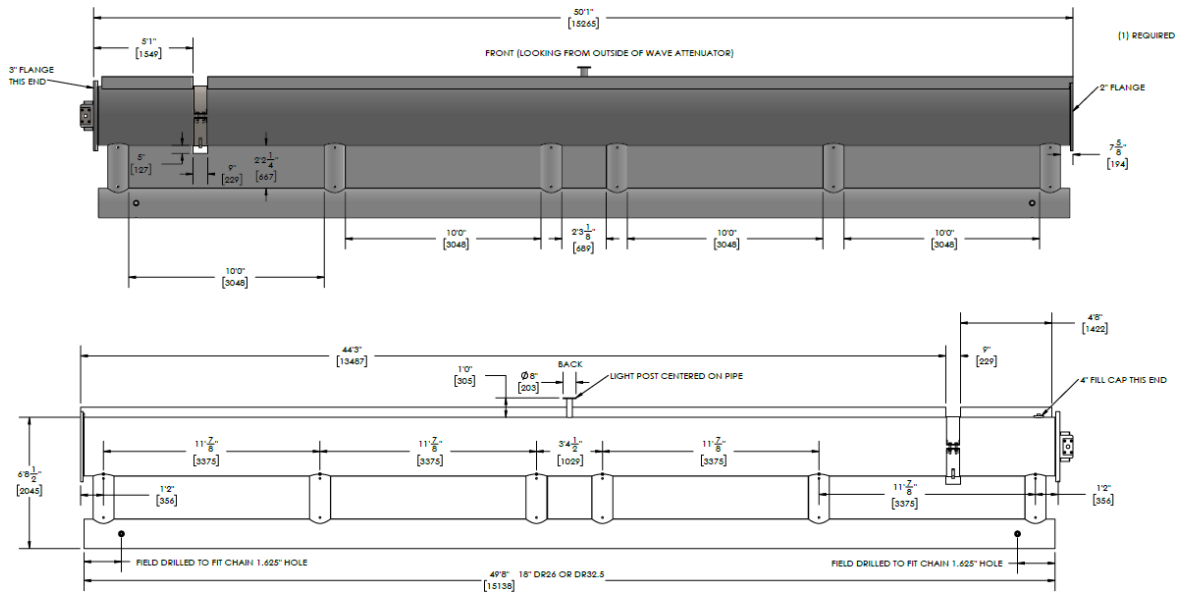



Figure 1: General Arrangement

36" Wave Attenuation Boom: 14 sections X 50', combined length of 700'

- 36-inch diameter Class 3, black color
- 50-foot Sections
- Water ballastable
- 8" x 1" Hi-Vis yellow splash guard – Federal Std. Color 1365
- Skirt: ½" hdpe sheet wall with 12" class 3 vertical and 18-inch class 3 lower pipes
- 100lb/ft used anchor chain for lower ballast
- Anchor pad eye/Backer rings and 1" A325 structural bolts
- Socket for light stands on each section (quoted as option)





24" class 3 wave attenuation boom: 10 sections x 50' – combined length Of 500'

- 24" diameter class 3, black color
- 50-foot Sections
- Water ballastable
- 8" x 1" Hi-Vis yellow top splashguard - Federal Std. Color 1365
- Skirt: 4' deep x 4ply 440 rubber attenuation skirt with 20lb/ft ballast weight attached.
- Anchor pad eye/Backer rings and 3/4" A325 structural bolts
- Socket for light stand (quoted as option)

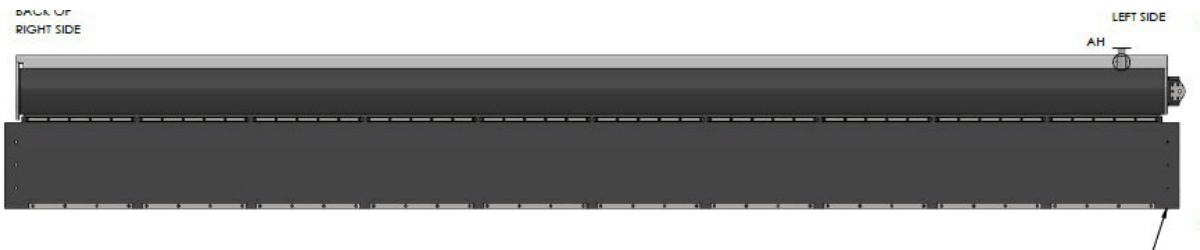



Signage:

As an option, 24 each sign brackets and signs were proposed as per RFP. Below picture represents PNP’s “standard” sized sign frame and signage. This of course can be modified to fit your particular needs and can be addressed during the design phase of the project.

Bolt on adjustable sign frame and sign with graphics to suit site.



Lighting:

As an option, 24 each navigational light are proposed as per RFP. Below picture represents PNP’s “standard” Light pedestal/light. Again, this can be modified to fit your needs and can be addressed during the design phase of the project.

SeaLite, Solar Marine Light, Model SL-60 with User-Adjustable Flash Settings, 1–2 NM w/ PNP mounting stand:





This page left blank intentionally.



In water anchoring:

There was limited information regarding anchoring of the wave attenuation system. Based on experience with our designs, we have chosen to offer a system using a series of concrete blocks and anchor cables to hold the boom in place and help resist wave loading effects. This design will be further reviewed and confirmed during design phase.

Anchor Blocks: Custom Manufactured by Hooker Creek Construction Materials – Bend Oregon

We are recommending pre-cast anchor blocks, like the sketch below but finished size of 2x2x6' with a weight of 3,600lbs dry weight. A 1.25-inch diameter galvanized bent rod will be placed within the block during the pour process for connection of the anchor cable.

60 each anchor blocks have been provided in our proposal. Spaced at 50' intervals on each side of the boom, will provide adequate holding power.

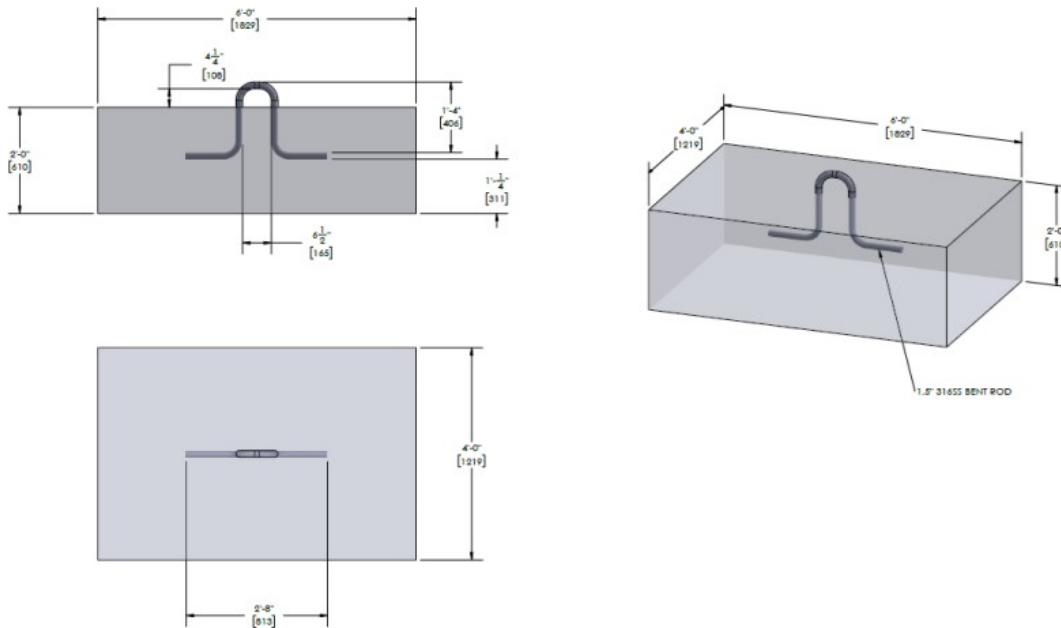



Anchor Lines:

Currently, we are recommending the use of ¾" IWRC galvanized wire rope for the anchor lines. The cable provides adequate strength and residue long term service life. Alternatively, stainless steel could be offered but not currently included in this proposal due to cost considerations.

Anchor materials quoted consist of:

60 each concrete anchor blocks 2x2x6'

¾" 6x19 galvanized wire x 8,000'

¾" galv. Drop forged wire rope clips (3 per eye splice)

¾" galv. Thimbles for each eye

1" galvanized safety anchor shackles to attach anchor cable to block and boom.

2 each 1-1/4" x 10' galvanized open link chain to attach boom end to shore anchors.

1-1/4" galvanized safety anchor shackles to attach boom to chain/boom to shore anchors.

Final anchor line design will be detailed out during design phase of project.



Shore anchors:

Limited information was provided within the RFP to fully vet best alternatives for anchor to shore. PNP has been involved on past projects around Lake Billy Chinook and realize there is a couple types of shore anchors that can be considered.

- 1) Pour in place concrete blocks - Site access is limited and may reduce the possibility of land-based equipment from reaching location. Shore grubbing and rock scaling to provide proper base for forming block will need to be performed/accessed from water. However, concrete could be pumped from land-based operation. Estimated concrete block size is 4x4x6’.
- 2) Drill and grout rock anchors – Again, site access is limited but good bedrock might be attainable to drill and epoxy grout anchor rods for attachment of a grouted galvanized steel pad eye base plate (shown below). Land based air supply could be provided for hand drill equipment.

Other considerations such as permitting, land ownership, environmental requirements will need to be discussed early in design phase to determine best approach moving forward.

PNP took into consideration, these two anchor options and captured the average costs within the installation portion of the proposal.

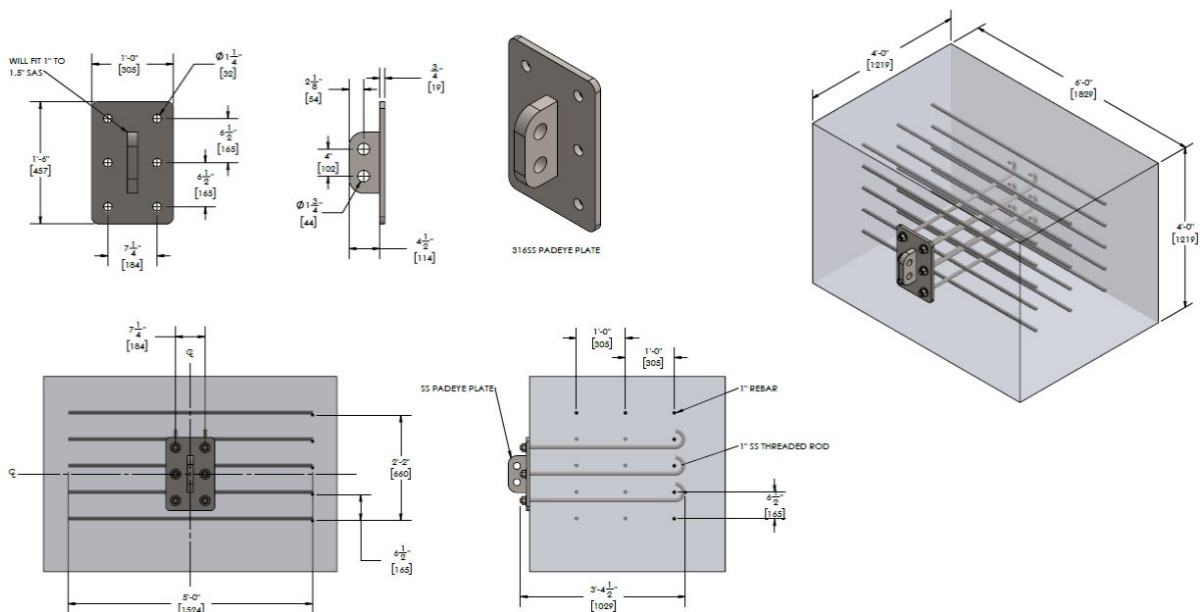



Shipping

11 each 48’ flatbed trucks will be required to ship all attenuator boom sections, ballast weight chain and anchoring hardware. In addition, 5 each 48’ flatbed trucks will be required to ship the 60 concrete anchor blocks. A 12K telehandler will be onsite for offloading equipment. It is assumed that material delivery will be located at final project site. Minimum laydown area requirement is 20,000 sq.ft



Delivery/Work Schedule:

Due to current project scheduling and long material lead times, PNP will have substantial portion of boom sections ready to ship prior to June 30. Remaining sections will be ready to ship on or before July 30.

However, PNP will have all materials for the boom manufacturing available at our Kingston WA. secured facility, cordoned off, tagged, and held specific for this project. On or before June 30, 2021.

March 5 –	Project award
March 10 –	Contract signing
March 15 –	Kick off meeting.
March – May	Design Phase
June -	Substantial delivery of materials
July	completion of fabrication - delivery of balance
November	Installation period



Installation:

Installation will be provided by Pacific Netting Products Inc.

Activities include:

Mob

Offloading attenuator equipment

Shore anchor construction (may require separate mob for install prior to attenuation deployment)

In lake anchor locating

Setting of anchors

Assembly of boom sections

Deployment of boom

Surface diving for final bolt up (underneath attenuator)

Attachment of anchor lines

Adjustment

PNP anticipates a portion of this work to be provided under PNP supervision by our primary sub-contractor – Harbor Offshore Inc.

PNP anticipates a 7-man crew to be onsite for the majority work schedule.

It is assumed that a 17-day work window will be required to perform all activities. Workdays will be M-F 7am-4pm



Payment Schedule:

Material payments will be invoiced net 30 as per section 3.9 of RFP.
Additional progress payments will be invoiced on the 15th of each month, due net 30.



Assumptions:

- 1) Permitting for project if required will be provided by others.
- 2) Anchoring design will be discussed between PNP and OSP to find best approach.
- 3) It will be acceptable to hold materials and or finished goods at PNP to meet best schedule for OSP.
- 4) Installation of system can take place after high season public use – assumed to be November time frame.
- 5) Excludes any state or local taxes that may apply.

Note on current HDPE raw material costs:

Due to the recent extreme winter storms in Texas, the raw HDPE material (hdpe chip) supply chain has become disrupted, resulting in material shortages, long lead times and significant increased cost. PNP has been staying in close contact with it's suppliers and believes that it is a short term issue, however, due to recent political changes, causing concern within the oil and natural gas sectors, is leading to a trend of higher prices.

PNP factored in the most recent price increases as of March 1. We anticipate the chance of further price increases but are committed to holding this proposal price schedule for 30 days.

We appreciate this opportunity and look forward to your questions and comments during the RFP review process.

Kindest Regards,

Dave Erickson

Dave Erickson

President PNP

25993 United RD NE

Kingston WA 98346

360-297-0858 office

206-795-1214 cell

www.pacificnettingproducts.com



CERTIFICATE OF QUALIFICATION

This certifies that
Adrian Madison

has completed training based on the requirements on

POLYETHYLENE BUTT HEAT FUSION 2" - 36"
ASTM F2620/TITLE 49 OF THE CFR # 192.285

GIVEN THIS 25TH DAY OF FEBRUARY, 2021 BY H.D. FOWLER
COMPANY.

Rusty Pressnall

H.D. Fowler Co. Service Department

February 25, 2021

Valid for two years

CERTIFICATE OF QUALIFICATION

This certifies that
Angelo Ritualo

has completed training based on the requirements on

POLYETHYLENE BUTT HEAT FUSION 2" - 36"
ASTM F2620/TITLE 49 OF THE CFR # 192.285

GIVEN THIS 25TH DAY OF FEBRUARY, 2021 BY H.D. FOWLER
COMPANY.

Rusty Pressnall

H.D. Fowler Co. Service Department

February 25, 2021

Valid for two years

DATALOGGER[®] 7

FUSION JOINT DATA COLLECTION & ANALYSIS



Capture the most important data from your fusion jobsite—no matter how long the workday. The DataLogger[®] 7 delivers increased battery life, automatic data backup, an updated Android operating system and more in a new, IP68-rated and MIL-STD-810 tested, rugged touchscreen tablet.

The DataLogger software helps to ensure that every joint was fused with the correct pressure and times according to supported standards by recording key parameters of the fusion process. Document heat soak times, heating pressure, open/close times, fusion time, fusion pressure, cool time along with jobsite details and operator information. A real-time graph gives immediate visual feedback regarding the integrity of each fusion joint. Joint records can be securely stored and analyzed online in the McElroy Vault[™] - allowing quick and easy sorting, tagging and sharing of joint records by machine, joint, operator, device or job.

ADDITIONAL IMAGES



SEE SECOND PAGE FOR DETAILED SPECIFICATIONS

STANDARD FEATURES

- ✓ Document fusion joint, operator and machine details including GPS locations
- ✓ Capture electrofusion, squeeze off techniques and pressure testing data
- ✓ 14+ hour battery capacity and a hot-swappable battery option
- ✓ IP68-rated rugged base tablet is waterproof, dust proof and shock proof
- ✓ Easy, simple-to-follow guided workflow
- ✓ Hard keys for easy navigation between applications
- ✓ Large, sunlight-readable 7" display with best-in-class outdoor visibility and clarity
- ✓ Automatic data backup to included SD card
- ✓ McElroy Optimized Cooling[™] algorithm allows for more joints to be completed in less time



DATALOGGER[®] 7

FUSION JOINT DATA COLLECTION & ANALYSIS

SPECIFICATIONS

MODELS		PERFORMANCE		CONNECTIVITY	
DLP0857716	DataLogger 7 - English, Spanish, and Russian	Battery	Removable Li-ion battery with 43.2 Whr and Internal 21.6 Whr battery providing hot-swap capability	Bluetooth	Long-range Bluetooth [®] Smart Ready wireless technology, v5.0 + EDR, Class 1.5, BLE support
WEIGHTS		Expandable Storage	User-accessible MicroSDXC card slot	Cellular Data	4G LTE multi-carrier capable
Machine	1.5 lbs. (0.7 Kg)	Operating System	Android 9	Wi-Fi	802.11 a/b/g/n/ac, 2.4 GHz and 5 GHz, 2x2 MIMO
MACHINE DIMENSIONS		Processor	Qualcomm [®] Snapdragon [™] Octa-core Kryo [™] 260	CAMERA	
Machine Length	8.5" (215.4mm)	Operating Temperature	-4 F to 122 F (-20 C to 50 C)	Front Camera	2 MP
Machine Width	5.4" (137.2mm)	RAM	6 GB LPDDR4x	Rear Camera	16 MP with LED illumination
Machine Height	1.4" (34.5mm)	Protection	IP68 waterproof, dustproof and shockproof (multiple drops from 4' (1.2 - 1.5 m) onto concrete), designed to meet MIL-STD-810G test procedures	INCLUDES	
SUPPORTED STANDARDS		Storage Capacity	64 GB or 128 GB flash storage options	Tablet, transducer, machine mount, stylus, micro SD card, carrying case and Quick Start Guide .	
Data Logging	ASTM F3124	Storage Temperature	-22 F to 158 F (-30 C to 70 C)		
Fusion	ASTM F2620, ISO 21307:2011-05, GIS/PL2-3-07, Profuse, DS /INF 70-2 PE:HD:1992-05, WIS 4-32-08:2002-04, DVS 2207-1 PE-HD:2005-09, DVS 2207-11 PP:2008-08, DS/INF 70-2 PP:1992-05				
SCREEN					
Active Viewing Area	7" (177.8 mm)				
Resolution	WXGA (1280 x 800)				
Touchscreen	Dragontrail [™] High Ion-Exchange (HIE [™])				

CERTIFICATE OF QUALIFICATION

This certifies that
Gabriel Paulino

has completed training based on the requirements on

POLYETHYLENE BUTT HEAT FUSION 2" - 36"
ASTM F2620/TITLE 49 OF THE CFR # 192.285

GIVEN THIS 25TH DAY OF FEBRUARY, 2021 BY H.D. FOWLER
COMPANY.

Rusty Pressnall

H.D. Fowler Co. Service Department

February 25, 2021

Valid for two years

CERTIFICATE OF QUALIFICATION

This certifies that
Joshua Bayne

has completed training based on the requirements on

POLYETHYLENE BUTT HEAT FUSION 2" - 36"
ASTM F2620/TITLE 49 OF THE CFR # 192.285

GIVEN THIS 25TH DAY OF FEBRUARY, 2021 BY H.D. FOWLER
COMPANY.

Rusty Pressnall

H.D. Fowler Co. Service Department

February 25, 2021

Valid for two years

LEISTER

Certificate of Attendance

We confirm that

of

Has completed attendance of Leister's on-site training demonstration module in the use of Leister hot air plastic welding tools.

Equipment that was covered during training included:

Extrusion Welders
Flooring Tools
Hot Air Hand Tools
Hot Gas Welding

Training Date:

Training Company:

Leister Technologies LLC

**Trainer: Dave
Rothbard**

David Rothbard

Signature

Leister Technologies LLC

U.S.A. www.leister.com

LEISTER

Certificate of Attendance

We confirm that

of

Has completed attendance of Leister's on-site training demonstration module in the use of Leister hot air plastic welding tools.

Equipment that was covered during training included:

Extrusion Welders
Flooring Tools
Hot Air Hand Tools
Hot Gas Welding

Training Date:

Training Company:

Leister Technologies LLC

**Trainer: Dave
Rothbard**

David Rothbard

Signature

Leister Technologies LLC

U.S.A. www.leister.com

LEISTER

Certificate of Attendance

We confirm that

of

Has completed attendance of Leister's on-site training demonstration module in the use of Leister hot air plastic welding tools.

Equipment that was covered during training included:

Extrusion Welders
Flooring Tools
Hot Air Hand Tools
Hot Gas Welding

Training Date:

Training Company:

Leister Technologies LLC

**Trainer: Dave
Rothbard**

David Rothbard

Signature

Leister Technologies LLC

U.S.A. www.leister.com

LEISTER

Certificate of Attendance

We confirm that

of

Has completed attendance of Leister's on-site training demonstration module in the use of Leister hot air plastic welding tools.

Equipment that was covered during training included:

Extrusion Welders
Flooring Tools
Hot Air Hand Tools
Hot Gas Welding

Training Date:

Training Company:

Leister Technologies LLC

**Trainer: Dave
Rothbard**

David Rothbard

Signature

Leister Technologies LLC

U.S.A. www.leister.com

LEISTER

Certificate of Attendance

We confirm that

of

Has completed attendance of Leister's on-site training demonstration module in the use of Leister hot air plastic welding tools.

Equipment that was covered during training included:

Extrusion Welders
Flooring Tools
Hot Air Hand Tools
Hot Gas Welding

Training Date:

Training Company:

Leister Technologies LLC

**Trainer: Dave
Rothbard**

David Rothbard

Signature

Leister Technologies LLC

U.S.A. www.leister.com

LEISTER

Certificate of Attendance

We confirm that

of

Has completed attendance of Leister's on-site training demonstration module in the use of Leister hot air plastic welding tools.

Equipment that was covered during training included:

Extrusion Welders
Flooring Tools
Hot Air Hand Tools
Hot Gas Welding

Training Date:

Training Company:

Leister Technologies LLC

**Trainer: Dave
Rothbard**

David Rothbard

Signature

Leister Technologies LLC

U.S.A. www.leister.com

LEISTER

Certificate of Attendance

We confirm that

of

Has completed attendance of Leister's on-site training demonstration module in the use of Leister hot air plastic welding tools.

Equipment that was covered during training included:

Extrusion Welders
Flooring Tools
Hot Air Hand Tools
Hot Gas Welding

Training Date:

Training Company:

Leister Technologies LLC

**Trainer: Dave
Rothbard**

David Rothbard

Signature

Leister Technologies LLC

U.S.A. www.leister.com

LEISTER

Certificate of Attendance

We confirm that

of

Has completed attendance of Leister's on-site training demonstration module in the use of Leister hot air plastic welding tools.

Equipment that was covered during training included:

Extrusion Welders
Flooring Tools
Hot Air Hand Tools
Hot Gas Welding

Training Date:

Training Company:

Leister Technologies LLC

**Trainer: Dave
Rothbard**

David Rothbard

Signature

Leister Technologies LLC

U.S.A. www.leister.com