

The Oregon Resilience Plan

Reducing Risk and Improving Recovery for the Next Cascadia Earthquake and Tsunami

Report to the
77th Legislative Assembly

from
Oregon Seismic Safety Policy
Advisory Commission (OSSPAC)



Salem, Oregon
February 2013

Cover Page graphic is designed by Deb Schueller with Oregon Department of Geology and Mineral Industries (DOGAMI)

2012-2013 Oregon Seismic Safety Policy Advisory Commission (OSSPAC) Members

CHAIR: Kent Yu - Structural Engineer Stakeholder, Degenkolb Engineers

VICE CHAIR: Jay Wilson - Public Member, Clackamas County Emergency Management

Deborah Boone - Representative, Legislative Assembly

Greg Ek-Collins - Oregon Department of Transportation

Carl Farrington - Multifamily Housing Stakeholder

Fred Girod - Senator, Legislative Assembly

David Holton - American Red Cross*

Francisco Ianni - American Red Cross

Ian Madin - Department of Geology and Mineral Industries

Michael Mumaw - Local Government Stakeholder, Emergency Manager, City of Beaverton

Jay Raskin - Public Member, Ecola Architects

Althea Rizzo - Oregon Emergency Management

Richard Rogers - Building Codes Division

Stephen Lucker - Department of Land Conservation & Development

Susan Steward – Building Owners Stakeholder, BOMA

Mark Tyler - Schools Stakeholder

Bryce Ward – Banking Stakeholder, ECONorthwest

Stan Watters – Utilities Stakeholder, Port of Portland

Gerry Williams - Public Member, Construction & Engineering Management Research, Inc.

Bev Hall – OSSPAC Secretary, Oregon Emergency Management

*Retired from the commission in June 2012.

Project Team and Acknowledgments

On behalf of my fellow OSSPAC Commissioners, I want to thank several individuals whose vision and support have made our resilience planning work possible. First and foremost, we thank our colleague Rep. Deborah Boone, who introduced House Resolution 3 and won the unanimous support of her colleagues on April 18, 2011. We are also grateful to Governor John Kitzhaber, who encouraged OSSPAC's efforts on resilience, and to President Barack Obama's Senior Director for Resilience Richard Reed, who took the time to express his support for the preparation of Oregon's resilience plan.

We are very grateful to members of the project Steering Committee, who have offered their advice, counsel, and support at every stage of our work: **Jay Wilson** (Vice Chair), **Ian Madin**, **Dr. Althea Rizzo**, and **Stan Watters**.

We appreciate the commitment of our Advisory Panel, whose members participated in meetings on January 26th, 2012 and October 5th, 2012 and have made themselves available for informal consultation over the past year: **Prof. Scott Ashford**, **Sen. Lee Beyer**, **Sen. Peter Courtney**, **Ed Dennis**, **JR Gonzalez**, **Prof. Chris Goldfinger**, **Dave Harlan**, **Onno Husing**, **Bruce Johnson**, **Dr. Leon Kempner, Jr.**, **Prof. Andre LeDuc**, **Dr. Vicki McConnell**, **Dr. Jean O'Connor**, **Cameron Smith**, **Jeffrey Soulages**, **Yumei Wang**, **Edward Wolf**, and **Dr. Nate Wood**. In particular, we want to thank Dr. Vicki McConnell, Yumei Wang and Edward Wolf for their guidance and support.

We owe the creation of the *Oregon Resilience Plan* to diligent efforts by our eight Task Groups and the capable leadership and project management performed by our Task Group leaders, who may not have fully realized the magnitude of the project when they agreed to serve:

Earthquake and Tsunami Scenario Task Group: **Ian Madin** (Chair), Bill Burns, Art Frankel, Chris Goldfinger, Matthew Mabey, George Priest, Yumei Wang, and Ivan Wong.

Business and Work Force Task Group: **Susan Steward** (Co-Chair), **Gerry Williams** (Co-Chair), Lori Chamberlain, Patrick Estenes, Kelley Okolita, Patrick Slabe, Bert Sorio, Jeffrey Soulages, Rick Van Dyke, and Bryce Ward.

Coastal Communities Task Group: **Jay Wilson** (Co-Chair), **Jay Raskin** (Co-Chair), Jacque Betz, Rep. Deborah Boone, Josh Bruce, Charlie Davis, Sue Graves, Dave Harlan, Jeffrey Hepler, Maggie Kirby, Sen. Jeff Kruse, Margo Lalich, Jack Lenox, Gary Milliman, Sam Steidel, Wayne Stinson, and Laren Woolley.

Critical Buildings Task Group: **Ed Quesenberry** (Co-Chair), **Trent Nagele** (Co-Chair), Andre Barbosa, David Bugni, Ed Dennis, Kimberly Dills, Shane Downing, Shelly Duquette, Jennifer Eggers, Joe Gehlen, Tonya Halog, Robert Johnson, Kevin Kaplan, Amit Kumar, Dominic Matteri, Anne Monnier, Willy Paul, Josh Richards, Tim Rippey, Richard Rogers, Terry Shugrue, Jason Thompson, Mark Tobin, Jim Weston, Michael Wieber, and Edward Wolf.

Transportation Task Group: *Bruce Johnson* (Chair), Martin Callery, Lieutenant Meredith Condon, Chris Corich, Peter Duskica, Greg Ek-Collins, Herb Florer, Doug Grafe, Elsie Hamner, Chuck Hutto, Doug Kirkpatrick, Jeff Langstrom, Lee Lazaro, Mark Libby, Matt Maass, Nason McCullough, Bob Melbo, Curran Mohney, Lucy Moore, Nancy Murphy, Albert Nako, David Neys, David Olongiagh, Jeff Olson, Jon Oshel, Tom Peterson, Craig Shike, Craig Totten, Tom Wharton, John Wilson, and Holly Winston.

Energy Task Group: *JR Gonzalez* (Co-Chair), *Stan Watters* (Co-Chair), Heide Caswell, Rick Carter, Brian Doherty, Michael Dougherty, Del Draper, Dave Ford, Debbie Guerra, Teresa Hagins, Marion Haynes, Leon Kempner, Jr., Brian Knight, Lori Koho, Christy Munro, Bruce Paskett, Robbie Roberts, Dave Stuckey, Jack Vranish, Yumei Wang, Tashiana Wanger, and Grant M. Yoshihara.

Information and Communications Task Group: *Mike Mumaw* (Chair), Rick Carter, Michael Dougherty, Walter Duddington, JR Gonzalez, Alexis Kwasinki, Devon Lumbard, Kelley Stember, Alex Tang, Yumei Wang, Stan Watters, and Geoffery Williams.

Water and Waste Water Task Group: *Mike Stuhr* (Co-Chair), *Mark Knudson* (Co-Chair), Don Ballantyne, Steve Behrandt, James Bela, Andy Braun, Scott Burns, Mel Damewood, Jim Doane, Michael Doane, Tom Hickmann, Gary Irwin, Gwynn Johnson, Jeff Leighton, Arturo Leon, Ian Madin, Jim Male, Jim Newell, Bob Patterson, Sherry Patterson, Todd Perimon, Brad Phelps, Jeff Rubin, Rob Schab, Ken Schlegel, Brian Stahl, and Jeffrey H. Winchester.

Dr. Kyra L. Nourse compiled and edited the *Oregon Resilience Plan*, with assistance from my OSSPAC colleagues Dr. Althea Rizzo, Jay Wilson, Ian Madin, Bev Hall and from Edward Wolf. We are grateful to FEMA for financial support, through a grant administered by Oregon Emergency Management, for the technical editing of the plan.

The Port of Portland hosted our workshops on January 26, 2012 and October 5, 2012 in its headquarter building. We want to thank Michelle Walker for her planning and coordination to make the workshops successful. Cascadia Region Earthquake Workgroup (CREW) provided their endorsement for our resilience planning efforts, and also helped sponsor our January 26, 2012 workshop. We want to thank Cale Ash (then President of CREW) and John Schelling (Washington State Emergency Management) for their participation and for sharing their resilience planning experience with us.

On a personal note, I wish to thank my colleagues at Degenkolb Engineers, particularly Chris Poland in San Francisco and Stacy Bartoletti in Seattle, for their inspiration on resilience, and colleagues in our Portland office including Liz Francis and Karla Richards who helped me to manage my resilience plan responsibilities without leaving my other professional obligations too far behind.

Finally, I want to acknowledge the leadership of OSSPAC's Vice Chair Jay Wilson, who has in every respect been a full partner in the vision and execution of the *Oregon Resilience Plan*, and who is a great champion for resilience.

Many other individuals have generously shared their expertise and perspective with us during the creation of this plan. OSSPAC bears the sole responsibility for any errors or omissions it contains.

A handwritten signature in black ink, appearing to read 'Kent Yu', with a stylized flourish at the end.

Kent Yu, Ph.D.

Chairman, Oregon Seismic Safety Policy Advisory Commission

Portland, Oregon

January 2013

Foreword

“If we cannot control the volatile tides of change, we can learn to build better boats.”

—Andrew Zollie and Ann Marie Healy, *Resilience: Why Things Bounce Back* (2012)

For more than 300 years, a massive geological fault off America’s northwest coast has lain dormant. Well into that interval, Meriwether Lewis and William Clark journeyed to the mouth of the Columbia River and returned to Washington, D.C. to tell the new United States about what came to be known as the Oregon Country. Tens of thousands of settlers crossed the Oregon Trail to establish communities throughout the Willamette Valley, in coastal valleys, and beside natural harbors. With the provisional government established in 1843 followed by statehood in 1859, the modern history of Oregon began. Industries rose and fell, cities and towns grew . . . and still the fault lay silent.

Not until the 1980s did scientists recognize the Cascadia subduction zone as an active fault that poses a major geological hazard to Oregon. A decade later, the state’s building codes were updated to address this newly revealed earthquake threat to the built environment.

Since that time, scientists have documented a long history of earthquakes and tsunamis on the Cascadia subduction zone, and state and local officials have urged Oregonians to prepare for the next one. In 1999, the state’s Department of Geology and Mineral Industries published a preliminary statewide damage and loss study identifying the dire consequences of a Cascadia earthquake and tsunami for Oregon’s infrastructure and for public safety.

One official who took that warning seriously was Senator Peter Courtney, Oregon’s unchallenged champion of earthquake safety and advocate for measures to protect students who attend unsafe schools. His legislative efforts over more than a decade launched a statewide assessment of schools and emergency response facilities, and established a state grant program to help fund seismic upgrades to hazardous schools and other critical facilities. Other than California, no state has done as much—yet the hazard surpasses the commitments Oregon has made to date.

In early 2011, we suggested in the pages of *The Oregonian* that Oregon should take new steps to make itself resilient to a big earthquake. Less than two months later, the Tohoku earthquake and tsunami disaster in Japan provided the occasion for Representative Deborah Boone to introduce a House Resolution calling on Oregon to plan for the impacts of a Cascadia earthquake and tsunami here.

House Resolution 3 directed Oregon Seismic Safety Policy Advisory Commission to lead the planning effort. Chairman Kent Yu, Ph.D., has skillfully guided more than 150 volunteer professionals, including noted experts, to develop a landmark report on Oregon’s priorities to survive and bounce back from a magnitude 9.0 Cascadia earthquake and tsunami.

The authors of this *Oregon Resilience Plan* set out to help Oregonians know what to expect from the state's infrastructure should that disaster strike this year, and to propose the level of infrastructure reliability that a resilient state should provide. The plan's recommendations highlight ways to close the gap that separates expected and desired performance.

Business leaders engaged in this resilience planning effort have indicated that in a major disaster, interruptions of infrastructure services lasting longer than two weeks will put their enterprises at risk. Yet, under present conditions, we can expect some interruptions to last much longer, in some cases from 18 to 36 months or more. The state, in tandem with the private sector, has much to do to improve the reliability of basic services. Citizens, too, need to plan to be self-sufficient for far longer than the 72-hour period commonly advised for disaster preparedness.

The most recent Cascadia earthquake struck at around 9:00 p.m. on a late January evening; the next could shake a mid-July morning when hundreds of thousands of Oregonians and visitors are enjoying coastal beaches and towns. No one can predict the next time the Cascadia fault will rupture, and *today* is just as likely as fifty years from now. If we begin now, it is possible to prevent that natural disaster from causing a statewide catastrophe. Now is the time to have a plan. Now is the time to close Oregon's resilience gap.

The Oregon Resilience Plan maps a path of policy and investment priorities for the next fifty years. The recommendations offer Oregon's Legislative Assembly and Governor immediate steps to begin a journey along that path. The plan and its recommendations build on the solid foundation laid over the past quarter century by some of Oregon's top scientists, engineers, and policymakers.

As we wrote two years ago, adopting and implementing such a plan can show "Oregon at its best, tackling a risk with imagination and resourcefulness while sharing the knowledge gained."

YUMEI WANG, JAY RASKIN, AND EDWARD WOLF

Portland, Oregon

November 2012

Yumei Wang, Jay Raskin, and Edward Wolf are the co-authors of "Oregon should make itself resilient for a big quake," *The Sunday Oregonian*, January 9, 2011.

Table of Contents

Project Team and Acknowledgments	iii
Foreword	vii
Executive Summary	xiii
1. Cascadia: Oregon’s Greatest Natural Threat	1
INTRODUCTION	
HOW OSSPAC DEVELOPED THIS PLAN	
GREAT EARTHQUAKES ON THE CASCADIA SUBDUCTION ZONE	
RESILIENCE PLAN EARTHQUAKE SCENARIO	
OREGON’S INFRASTRUCTURE AND RISK	
ESTIMATED IMPACTS	
REFERENCES	
2. Business and Workforce Continuity	17
INTRODUCTION	
EVALUATION OF THE SCENARIO EARTHQUAKE’S ECONOMIC IMPACT	
BUSINESS WORKFORCE INTERDEPENDENCY	
CONSIDERATIONS FOR DIFFERENT SECTORS	
CASCADIA EARTHQUAKE AFTERMATH	
CASCADIA EARTHQUAKE BUSINESS PLANNING	
REFERENCES	
3. Coastal Communities	47
INTRODUCTION	
EARTHQUAKE AND TSUNAMI ZONES	
AFTER THE CASCADIA EVENT	
COASTAL ZONE TARGETS	

GOVERNMENT/ESSENTIAL FACILITY CONTINUITY

LAND USE

RECONSTRUCTION

COASTAL ECONOMIC RESILIENCE

DISASTER RESILIENCE AND SUSTAINABILITY

RELIEF AND RESILIENCE RATINGS

REFERENCES

4. Critical and Essential Buildings

73

INTRODUCTION

BUILDING DATA AND ANALYSIS

TARGET STATES OF RECOVERY

ASSESSMENT OF CURRENT BUILDING PERFORMANCE: SECTOR BY SECTOR

Emergency Operations Centers, Police, and Fire Stations

Education Facilities

Healthcare Facilities

Emergency Sheltering

Critical Government Facilities

Residential Housing

Community Retail Centers and Banks

Vulnerable Buildings

FINDINGS AND RECOMMENDATIONS

REFERENCE

5. Transportation

105

INTRODUCTION

ASSESSMENT OF TRANSPORTATION PERFORMANCE

Highway Transportation

Rail Transportation

Air Transportation

Columbia and Willamette Navigation Channels

Public Transit Services

Local Roads and Streets

RESILIENCE GAP ANALYSIS SUMMARY

TRANSPORTATION INTERDEPENDENCY ASSESSMENT

RECOMMENDATIONS

REFERENCES

6. Energy

161

INTRODUCTION

OREGON'S CRITICAL ENERGY INFRASTRUCTURE HUB

Liquid Fuel

Natural Gas

Electricity

Findings of the Bonneville Power Administration

OPERATOR EFFORTS TO PREPARE FOR A CASCADIA SUBDUCTION ZONE EVENT

RECOMMENDATIONS

REFERENCES

7. Information and Communications

179

INTRODUCTION

RESILIENCE GOAL, OBJECTIVES, AND SCOPE

PLAN DEVELOPMENT

ASSESSMENT OF PERFORMANCE

RESILIENCE GAP ANALYSIS SUMMARY

RECOMMENDATIONS

TARGET TIMEFRAMES FOR RECOVERY	
REFERENCES	
8. Water and Wastewater Systems	203
INTRODUCTION	
WATER AND WASTEWATER RESILIENCE PLANNING	
ASSESSMENT OF SYSTEM PERFORMANCE	
ASSESSMENT OF WATER AND WASTEWATER STRUCTURES	
ESTIMATED RECOVERY TIMEFRAMES FOR EXISTING SYSTEMS	
RECOMMENDATIONS	
REFERENCES	
9. Looking Ahead	241
Appendix I: House Resolution 3 and Supporting Documentation	243
Appendix II: January 26, 2012 Workshop	253
Appendix III: October 5, 2012 Workshop	281
Appendix IV: List of Oregon Resilience Plan Contributors	305

Executive Summary

Very large earthquakes will occur in Oregon’s future, and our state’s infrastructure will remain poorly prepared to meet the threat unless we take action now to start building the necessary resilience. This is the central finding of the *Oregon Resilience Plan* requested by Oregon’s 76th Legislative Assembly.

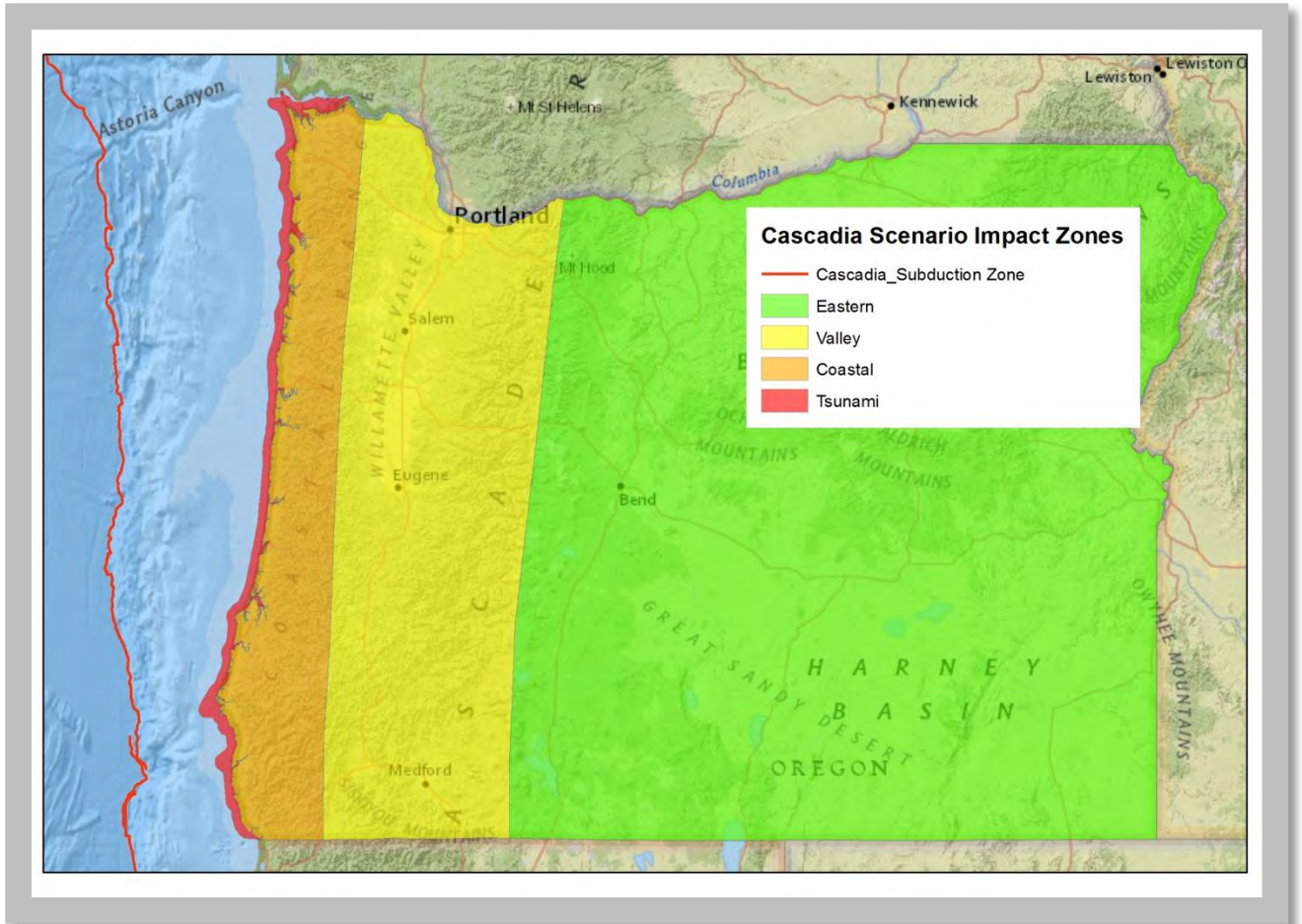

Impact zones for the magnitude 9.0 Cascadia earthquake scenario. Damage will be extreme in the Tsunami zone, heavy in the Coastal zone, moderate in the Valley zone, and light in the Eastern zone.

About the Plan

House Resolution 3, adopted in April 2011, directed the Oregon Seismic Safety Policy Advisory Commission (OSSPAC) “to lead and coordinate preparation of an Oregon Resilience Plan that reviews policy options, summarizes relevant reports and studies by state agencies, and makes recommendations on policy direction to protect lives and keep commerce flowing during and after a Cascadia earthquake and tsunami.” OSSPAC assembled eight task groups, comprising volunteer subject-matter experts from government, universities, the private sector, and the general public. An Advisory Group of public- and private-sector leaders oversaw the Task Groups’ work, assembled in the portfolio of chapters that make up the plan.

OSSPAC offered the following definition of the seismic resilience goal:

“Oregon citizens will not only be protected from life-threatening physical harm, but because of risk reduction measures and pre-disaster planning, communities will recover more quickly and with less continuing vulnerability following a Cascadia subduction zone earthquake and tsunami.”

Each group was charged with three tasks for four affected zones (tsunami, coastal/earthquake only, valley, and central/eastern Oregon):

1. Determine the **likely impacts** of a magnitude 9.0 Cascadia earthquake and tsunami on its assigned sector, and estimate the time required to restore functions in that sector if the earthquake were to strike under present conditions;
2. Define **acceptable timeframes** to restore functions after a future Cascadia earthquake to fulfill expected resilient performance; and
3. Recommend **changes in practice and policies** that, if implemented during the next 50 years, will allow Oregon to reach the desired resilience targets.

The purpose of the analysis is to identify steps needed to eliminate the gap separating current performance from resilient performance, and to initiate that work through capital investment, new incentives, and policy changes so that the inevitable natural disaster of a Cascadia earthquake and tsunami will not deliver a catastrophic blow to Oregon’s economy and communities.

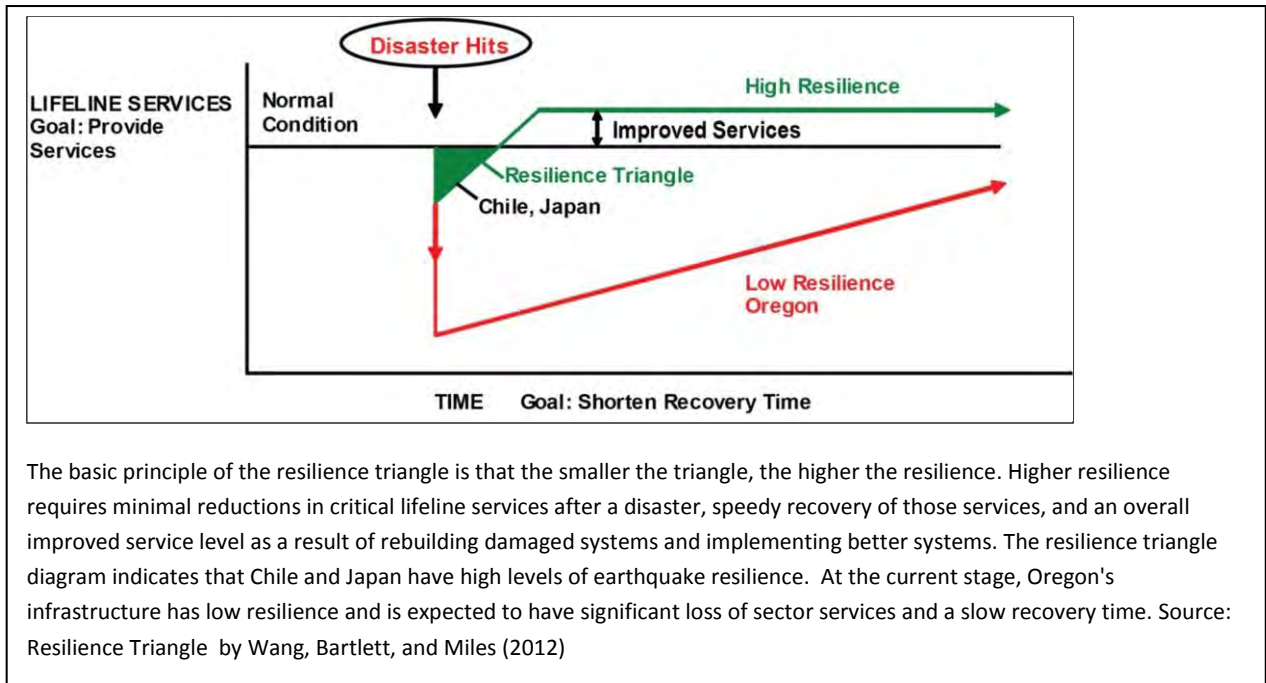

The basic principle of the resilience triangle is that the smaller the triangle, the higher the resilience. Higher resilience requires minimal reductions in critical lifeline services after a disaster, speedy recovery of those services, and an overall improved service level as a result of rebuilding damaged systems and implementing better systems. The resilience triangle diagram indicates that Chile and Japan have high levels of earthquake resilience. At the current stage, Oregon's infrastructure has low resilience and is expected to have significant loss of sector services and a slow recovery time. Source: Resilience Triangle by Wang, Bartlett, and Miles (2012)

Overview of the Task Groups

The **Cascadia Earthquake Scenario Task Group** (Chapter One) reviewed current scientific research to develop a detailed description of the likely physical effects of a great (magnitude 9.0) Cascadia subduction zone earthquake and tsunami, providing a scenario that other task groups used to assess impacts on their respective sectors.

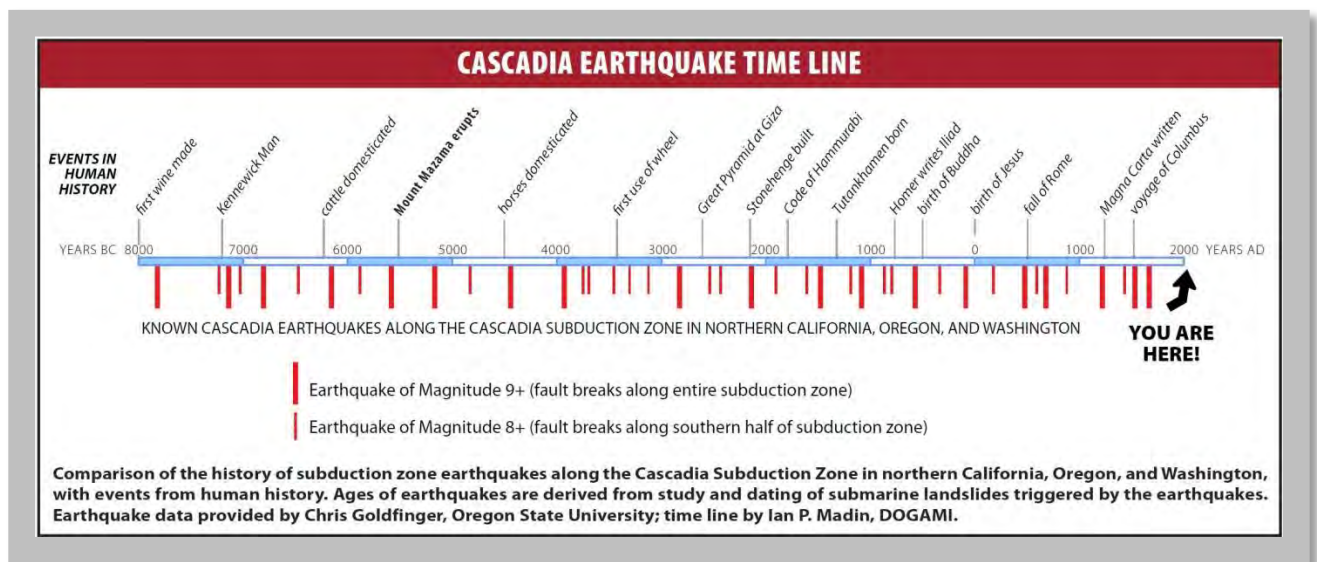

This timeline compares the 10,000-year-long history of Cascadia earthquakes to events in human history.

The **Business and Workforce Continuity Task Group** (Chapter Two) sought to assess the workplace integrity, workforce mobility, and building systems performance – along with customer viability – needed to allow Oregon’s businesses to remain in operation following a Cascadia earthquake and tsunami and to drive a self-sustaining economic recovery.

The **Coastal Communities Task Group** (Chapter Three) addressed the unique risks faced by Oregon’s coast, the region of the state that will experience a devastating combination of tsunami inundation and physical damage from extreme ground shaking due to proximity to the subduction zone fault.

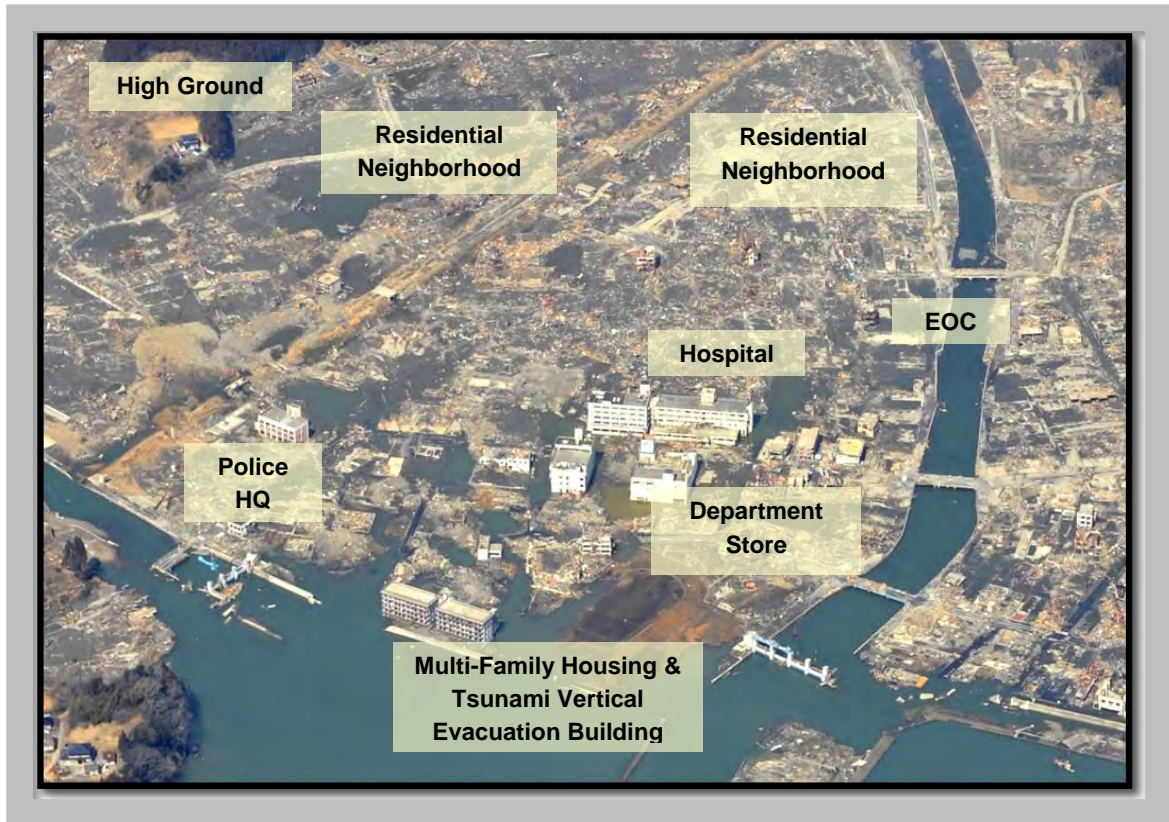

Critical Facilities in the Tsunami Zone – Minamisanriku, March 14, 2011. Because their hospital, emergency operation center, and other government and community service facilities were located in the tsunami inundation zone, the surviving community lost nearly all of its capacity to respond and implement recovery efforts. Source: Asia Air Survey Co., Ltd.

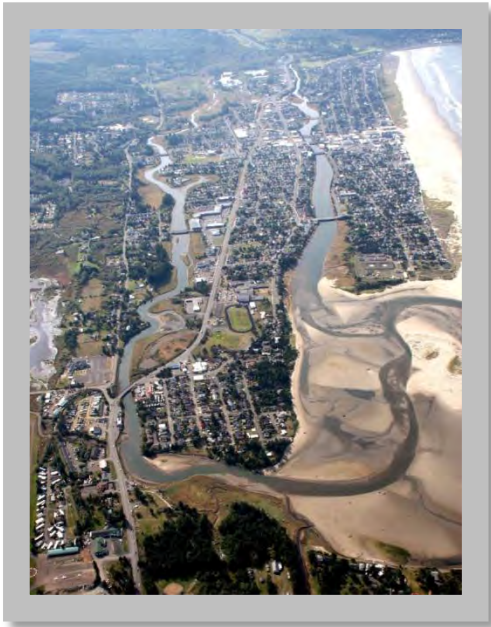

Tsunami Vulnerability: City of Seaside with 83% of its population, 89% of its employees and almost 100% of its critical facilities in the tsunami inundation zone. Source: Horning Geosciences

The **Critical and Essential Buildings Task Group** (Chapter Four) examined the main classes of public and private structures considered critical to resilience in the event of a scenario earthquake, and sought to characterize the gap between expected seismic performance (current state) and desired seismic resilience (target state). The group also assessed buildings deemed vital to community resilience, and addressed the special challenges posed by unreinforced masonry (URM) and non-ductile concrete structures.



Many of existing public and private buildings such as the State Capitol Building were built prior to our knowledge of the Cascadia subduction earthquake. They are not seismically safe, and pose significant life-safety threat to the building occupants. Photo Source:

http://en.wikipedia.org/wiki/File:Oregon_State_Capitol_1.jpg

The **Transportation Task Group** (Chapter Five) assessed the seismic integrity of Oregon’s multi-modal transportation system, including bridges and highways, rail, airports, water ports, and public transit systems, examined the special considerations pertaining to the Columbia and Willamette River navigation channels, and characterized the work deemed necessary to restore and maintain transportation lifelines after a Cascadia earthquake and tsunami. The group’s scope included interdependence of transportation networks with other lifeline systems.



The approach (foreground) to the 1966 Astoria-Megler Bridge that spans the Columbia River has major structural deficiencies that could lead to a collapse following an earthquake. Damaged bridge sections could block waterway access to the Critical Energy Infrastructure Hub. (DOGAMI photo)

The **Energy Task Group** (Chapter Six) investigated the seismic deficiencies of Oregon’s energy storage and transmission infrastructure, with a special emphasis on the vulnerability of the state’s critical energy infrastructure (CEI) hub, a six-mile stretch of the lower Willamette River where key liquid fuel and natural gas storage and transmission facilities and electricity transmission facilities are concentrated.



Left: Site map of the Critical Energy Infrastructure (CEI) Hub on the western bank of the Lower Willamette River area in NW Portland, Oregon. The CEI Hub, outlined in red, stretches for six miles. (Google Earth) Right: Oil terminals in the CEI Hub. (DOGAMI photo)

The **Information and Communications Task Group** (Chapter Seven) examined the inherent vulnerabilities of Oregon’s information and communications systems and the consequences of service disruptions for the resilience of other sectors and systems. The group explored the implications of co-location of communications infrastructure with other vulnerable physical infrastructure (e.g., bridges), and specified the conditions needed to accomplish phased restoration of service following a Cascadia earthquake and tsunami.



Left: These high voltage electrical transmission towers are built on a river bank in the Critical Energy Infrastructure (CEI) Hub susceptible to lateral spreading. (DOGAMI photo) Right: Structural damage to a high voltage transmission tower located at a river crossing in 2010 Chile earthquake (ASCE Technical Council on Lifeline Earthquake Engineering – TCLEE)

The **Water and Wastewater Task Group** (Chapter Eight) reviewed vulnerabilities of the pipelines, treatment plants, and pump stations that make up Oregon’s water and wastewater systems, and discussed the interventions needed to increase the resilience of under-engineered and antiquated infrastructure at potential failure points. The group proposed a phased approach to restoration of water services after a Cascadia earthquake and tsunami, beginning with a backbone water and wastewater system capable of supplying critical community needs.

Key Findings

Oregon is far from resilient to the impacts of a great Cascadia earthquake and tsunami today.

Available studies estimate fatalities ranging from 1,250 to more than 10,000 due to the combined effects of earthquake and tsunami, tens of thousands of buildings destroyed or damaged so extensively that they will require months to years of repair, tens of thousands of displaced households, more than \$30 billion in direct and indirect economic losses (close to one-fifth of Oregon’s gross state product), and more than one million dump truck loads of debris.

A particular vulnerability is Oregon’s liquid fuel supply. Oregon depends on liquid fuels transported into the state from Washington State, which is also vulnerable to a Cascadia earthquake and tsunami. Once here, fuels are stored temporarily at Oregon’s critical energy infrastructure hub, a six-mile stretch of the

lower Willamette River where industrial facilities occupy liquefiable riverside soils. Disrupting the transportation, storage, and distribution of liquid fuels would rapidly disrupt most, if not all, sectors of the economy critical to emergency response and economic recovery.

Business continuity planning typically assumes a period of two weeks to be the longest disruption of essential services (*i.e.*, utilities, communications, etc.) that a business can withstand, and service disruptions lasting for one month or longer can be enough to force a business to close, relocate, or leave the state entirely. Analysis in the *Oregon Resilience Plan* reveals the following timeframes for service recovery under present conditions:

Critical Service	Zone	Estimated Time to Restore Service
Electricity	Valley	1 to 3 months
Electricity	Coast	3 to 6 months
Police and fire stations	Valley	2 to 4 months
Drinking water and sewer	Valley	1 month to 1 year
Drinking water and sewer	Coast	1 to 3 years
Top-priority highways (partial restoration)	Valley	6 to 12 months
Healthcare facilities	Valley	18 months
Healthcare facilities	Coast	3 years

Resilience gaps of this magnitude reveal a harsh truth: a policy of business as usual implies a post-earthquake future that could consist of decades of economic and population decline – in effect, a “lost generation” that will devastate our state and ripple beyond Oregon to affect the regional and national economy.

- After the February 27, 2010 M8.8 Maule Earthquake, Chile was able to restore 90% communication services and 95% power supply within two weeks, and re-start commercial flights after ten days.
- After the March 11, 2011 M9.0 Tohoku Earthquake, Japan was able to restore more than 90% power supply in ten days, 90% telephone lines in two weeks, and 90% cellular base stations in 19 days.



Recommendations

Based on the findings in this *Oregon Resilience Plan*, OSSPAC recommends that Oregon start now on a sustained program to reduce our vulnerability and shorten our recovery time to achieve resilience before the next Cascadia earthquake inevitably strikes our state.

OSSPAC urges systematic efforts to assess Oregon’s buildings, lifelines, and social systems, and to develop a sustained program of replacement, retrofit, and redesign to make Oregon resilient.

Sector-by-sector findings and detailed recommendations are presented in each chapter of the *Oregon Resilience Plan*. Overarching priorities, illustrated with examples selected from the chapters, include new efforts to:

1. Undertake **comprehensive assessments** of the key structures and systems that underpin Oregon’s economy, including
 - a. Completing a statewide inventory of critical buildings (those needed for emergency response and the provision of basic services to communities) in both public and private sectors (Chapter Four);
 - b. Completing an updated inventory of the local agency, transit, port, and rail assets that assure access to school buildings and hospitals and could be used during emergencies (Chapter Five);
 - c. Charging the Oregon Public Utility Commission to define criteria for seismic vulnerability assessments that will be applied by operating companies in the energy and information and communications sectors (Chapters Six and Seven); and
 - d. Requiring all water and wastewater agencies to complete a seismic risk assessment and mitigation plan as part of periodic updates to facility plans (Chapter Eight).
2. Launch a sustained **program of capital investment** in Oregon’s public structures, including
 - a. Fully funding Oregon’s Seismic Rehabilitation Grants Program for K-12 schools, community colleges, and emergency response facilities (Chapters Two and Four);
 - b. Seismically upgrading lifeline transportation routes into and out of major business centers statewide by 2030 (Chapter Five); and
 - c. Establishing a State Resilience Office to provide leadership, resources, advocacy, and expertise in implementing statewide resilience plans (Chapter Four).
3. Craft a **package of incentives** to engage Oregon’s private sector in efforts to advance seismic resilience, including
 - a. Developing a seismic rating system for new buildings to incentivize construction of buildings more resilient than building code compliance requires and to communicate seismic risk to the public (Chapters Two and Four);
 - b. Tasking the Oregon Public Utilities Commission to provide oversight for seismic preparedness of the energy providers currently under its jurisdiction (Chapter Six); and

- c. Working with the hospitality industry to develop plans to assist visitors following a major earthquake and tsunami and to plan strategies to rebuild the tourism industry (Chapter Three).
4. **Update Oregon’s public policies**, including
 - a. Revising individual preparedness communications to specify preparation from the old standard of 72 hours to a minimum of two weeks, and possibly more (Chapters Two and Three);
 - b. Developing a policy and standards for installation of temporary bridges following earthquake disruption (Chapter Five); and
 - c. Adopting a two-tiered ratings system that indicates the number of hours/days that a citizen in a community can expect to wait before major relief arrives, and the number of days/months that a citizen can expect to wait before the community itself achieves 90 percent restoration of roads and municipal services (Chapter Two).

These and other recommendations may be refined and implemented via a combination of new legislation, regulations, administrative rules, budget priorities, and in consultation with private sector leaders as appropriate.

Looking Ahead

This *Oregon Resilience Plan* emphasizes the resilient physical infrastructure needed to support business and community continuity. The policy recommendations presented here, if implemented over the next 50 years, will enhance our infrastructure resilience, help preserve our communities, and protect our state economy.

This is a timeframe much longer than typical of government planning efforts. To affirm Oregon’s commitment, OSSPAC needs to work with the Joint Ways & Means Committee of Oregon’s Legislative Assembly to track and report on progress toward seismic resilience at the beginning of each legislative session, to keep the 50-year goal in view.

Local Oregon communities can use the framework and gap-analysis methodology developed by the *Oregon Resilience Plan* to conduct more refined assessments that consider local seismic and tsunami hazards, and develop community-specific recommendations to meet their response and recovery needs.

A Cascadia earthquake and tsunami will affect both Oregon and Washington. Both states share common challenges, among them the interstate bridges and the Columbia River navigation channel as well as the regional power grid and liquid fuel supply. In particular, Oregon gets almost one hundred percent of its liquid fuel from suppliers in Washington, delivered via pipeline and river. We believe that it would be beneficial for both states to work together at a regional level to address the common challenge of resilience to a region-wide seismic event.

OSSPAC recommends expanding future resilience planning efforts to include:

1. Community-level planning
2. Human resilience
3. Civic infrastructure
4. Joint regional planning with Washington State

With resilient physical infrastructure, a healthy population, and functioning government and civic infrastructure to provide services to those in need, Oregon will be ready to withstand a Cascadia earthquake and tsunami, and to expedite response and recovery efforts quickly.

NOTE: This Executive Summary selects from the large number of detailed recommendations in the chapters of the *Oregon Resilience Plan*. The full report is available online at the Oregon Office of Emergency Management website: <http://www.oregon.gov/OMD/OEM/Pages/index.aspx>

1. Cascadia: Oregon’s Greatest Natural Threat

Introduction

When, not if, the next great Cascadia subduction zone earthquake strikes the Pacific Northwest, Oregon will face the greatest challenge in its history. Oregon’s buildings, transportation network, utilities, and population are simply not prepared for such an event. Were it to occur today, thousands of Oregonians would die, and economic losses would be at least \$32 billion. In their current state, our buildings and lifelines (transportation, energy, telecommunications, and water/wastewater systems) would be damaged so severely that it would take three months to a year to restore full service in the western valleys, more than a year in the hardest-hit coastal areas, and many years in the coastal communities inundated by the tsunamis. Experience from past disasters has shown that businesses will move or fail if services cannot be restored in one month; so Oregon faces a very real threat of permanent population loss and long-term economic decline.

We cannot avoid the future earthquake, but we can choose either a future in which the earthquake results in grim damage and losses and a society diminished for a generation, or a future in which the earthquake is a manageable disaster without lasting impact. We need to start preparing now by assessing the vulnerability of our buildings, lifelines, and social systems, and then developing and implementing a sustained program of replacement, retrofit, and redesign to make Oregon resilient to the next great earthquake. We know how to engineer buildings, roads, and power lines to withstand this earthquake; the hard part will be to find the will, commitment, and persistence needed to transform our state.

The Oregon legislature recognized the scale of this problem when it passed House Resolution 3 in 2011 (see Appendix I for details of House Resolution 3), noting the likely impact of a Cascadia earthquake and the need for a plan to move the state towards resilience to that event. The Oregon Seismic Safety Policy Advisory Commission (OSSPAC) was charged with developing a resilience plan, which is described in this report. The report summarizes the science of Cascadia subduction zone earthquakes and estimates their impacts; it then provides detailed analysis of the current vulnerability of our buildings and business community, and our transportation, energy, communication, and water/wastewater systems. The report defines the performance targets that each sector must meet to achieve adequate resilience, and provides detailed recommendations for the actions required to meet those targets over the next 50 years.

How OSSPAC Developed This Plan

House Resolution 3 passed by the 2011 legislature directed OSSPAC to “lead and coordinate preparation of an Oregon Resilience Plan that reviews policy options, summarizes relevant reports and studies by state agencies and makes recommendations on policy direction to protect lives and keep commerce

flowing during and after a Cascadia earthquake and tsunami”. To meet this challenge OSSPAC first defined what resilience would mean for Oregon:

Oregon citizens will not only be protected from life-threatening physical harm, but because of risk reduction measures and pre-disaster planning, communities will recover more quickly and with less continuing vulnerability following a Cascadia subduction zone earthquake and tsunami.

OSSPAC identified existing and ongoing earthquake resilience planning from San Francisco, California (SPUR, 2009) and the State of Washington (Washington Seismic Safety Committee, 2012) as good models to follow. These studies outlined an approach that included estimating the current earthquake vulnerability of systems and structures, defining the performance standards that structures and systems would need to meet over fifty years in order to be sufficiently resilient, and then identifying changes in practice and policy that would help attain those performance standards. One difference for the Oregon Resilience Plan was that it needed to encompass the entire state unlike the City of San Francisco study, and that it focused on the Cascadia earthquake threat, unlike the Washington study which considered multiple earthquake scenarios.

To complete the plan without funding and on a one-year schedule, OSSPAC chose to tap into volunteer expertise from Oregon’s academic, professional, governmental and public communities. Over one hundred volunteer experts drawn from a broad section of Oregon society were organized into eight work groups to survey the following parts of the problem:

- Cascadia Earthquake Scenario
- Business and Workforce
- Coastal Communities
- Critical and Essential Buildings
- Energy
- Transportation
- Information and Communications
- Water and Wastewater

The purpose of the task group assigned to the Cascadia Earthquake Scenario was to develop a detailed description of the likely physical effects throughout Oregon of a major Cascadia subduction earthquake so that the other groups could assess the impact on their respective sectors. Each of the remaining seven groups focused on one of the sectors of society or parts of the built environment listed above. The Coastal Task Group was included to recognize the unique risk along the coast: this region will experience a combination of tsunami damage and damage from extreme shaking.

Each group was charged with three primary tasks: First, determine the likely impact of the scenario earthquake on the assigned sector and estimate the time required to restore functions in that sector if

the earthquake were to happen under current conditions. Second, define performance targets for the sector. The targets represent the desired timeframes for restoring functions in a future Cascadia earthquake—in other words, the timeframes within which functions must be restored if Oregon is to be resilient. Finally, provide a series of recommendations to OSSPAC for changes in practice and policy that, if implemented, would ensure that Oregon reaches the desired resilience targets over the next 50 years.

The products from the various task groups were reviewed by an advisory group of subject matter experts to ensure that the material was accurate, complete, and up-to-date. OSSPAC then reviewed the recommendations and selected and endorsed those that the commission felt offered the most effective way to achieve resilience to a great Cascadia disaster.

Great Earthquakes on the Cascadia Subduction Zone

For the last twenty-five years, the scientific community has been aware of the possibility that a great earthquake caused by the Cascadia subduction zone could strike the Pacific Northwest. Now, after decades of research and recent great earthquakes in Sumatra, Chile, and Japan, awareness of this threat is widespread in Oregon, and we know enough to paint a picture of what Oregon might look like after such an earthquake. Oregon is a geologic mirror image of northern Japan (see Figure 1.1). In both places, the Pacific Ocean floor is sliding beneath the adjacent continents along giant faults called subduction zones. The scientific understanding of the Cascadia threat makes it clear that very large earthquakes will occur in Oregon’s future, and that our societal and physical structures are poorly prepared to meet the threat unless we take action now to start building the necessary resilience.

What Are Subduction Zone Earthquakes?

The surface of the earth is broken into dozens of tectonic plates—continent-sized slabs of rigid rock that slowly slide across the more pliant mantle of the earth beneath. Moving at speeds of a few inches per year, the plates can pull apart, slide past each other, or collide head on. Where an oceanic and a continental plate collide, a subduction zone forms, as one plate is forced beneath the other, deep into the softer rock of the mantle. A great arc of subduction zones surrounds the Pacific Ocean, producing what geologists call the “Ring of Fire.” In Japan, the ocean floor of the Pacific Plate moves towards the west, sliding beneath the Eurasian Plate that supports the islands of Japan. The Pacific Northwest is a geologic mirror image of Japan, with the Pacific Ocean floor moving towards the east, sliding beneath Oregon, Washington, and Northern California along a 600-mile fault called the Cascadia subduction zone.

In Japan, there has never been any doubt that great subduction earthquakes are possible: Japan’s long written history has recorded many such events, with the 2011 Tohoku earthquake being the most recent and one of the most powerful and destructive. In that earthquake, a section of the Pacific Ocean floor measuring 300 miles long and 125 miles wide lurched as much as 100 feet down the subduction zone, causing a great magnitude 9.0 earthquake. The eastern edge of the Eurasian Plate, which had been slowly bending for centuries under the relentless pressure of subduction, snapped back during the

earthquake, displacing trillions of tons of seawater and triggering a catastrophic tsunami. The release of the bent Eurasian Plate caused land along the coast of Japan to permanently sink several feet, and the strong shaking from the earthquake caused widespread landslides on steep slopes (both on land and undersea) and widespread liquefaction of soft sediments on land.

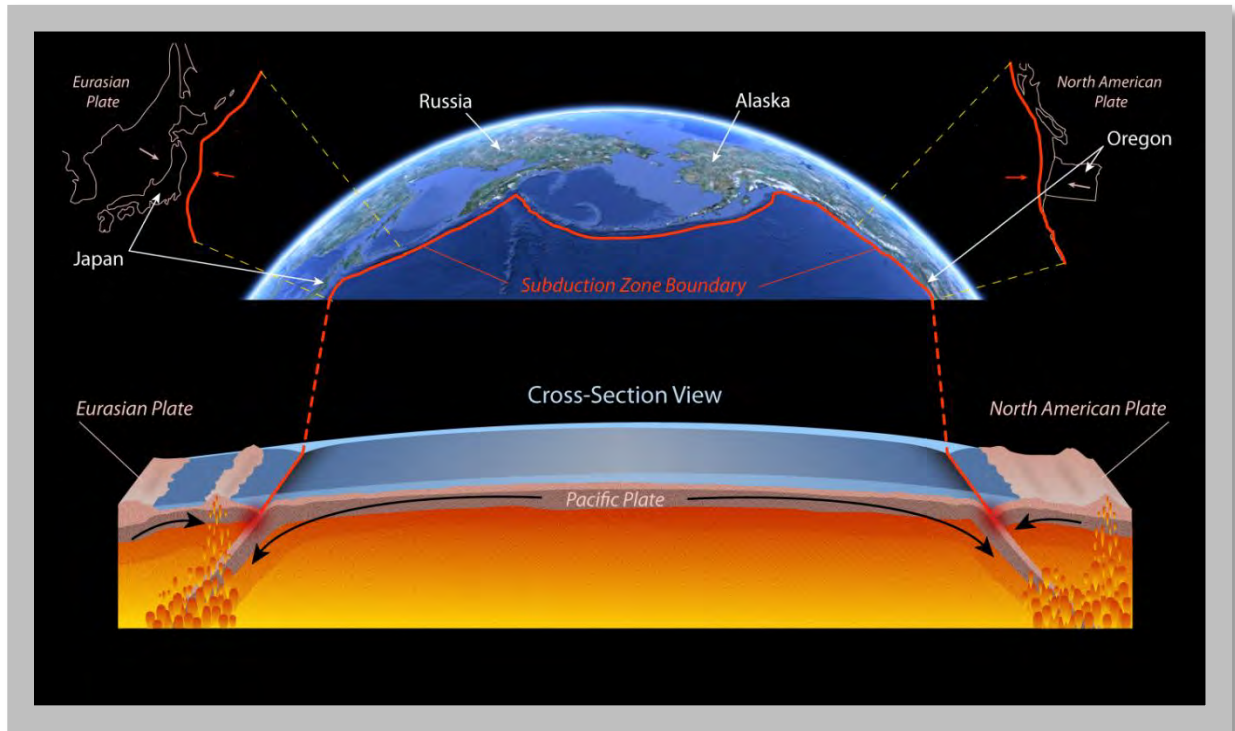

Figure 1.1: Oregon is a geologic mirror-image of Northern Japan. In both places, the Pacific Ocean floor is sliding beneath the adjacent continents along giant faults called subduction zones (Source: Graphic by Dan Coe, DOGAMI).

In 1984, when seismologists first proposed that Cascadia might produce similar earthquakes, there was considerable doubt. Research since then has confirmed that Cascadia has a long history of great subduction earthquakes and that energy for the next great earthquake is currently building along the fault. Geologic studies (see Figure 1.2) have uncovered evidence of the coastal subsidence, tsunamis, landslides, and liquefaction that were produced by past Cascadia earthquakes, and ultra-sensitive GPS measurements show that the Oregon coast is moving eastward a few inches per year along with the Pacific Ocean floor, motion that will be abruptly reversed during the next great subduction earthquake. There is no scientific doubt that another great subduction earthquake will strike the Pacific Northwest; the questions now are how soon, how large, and how destructive that earthquake will be.

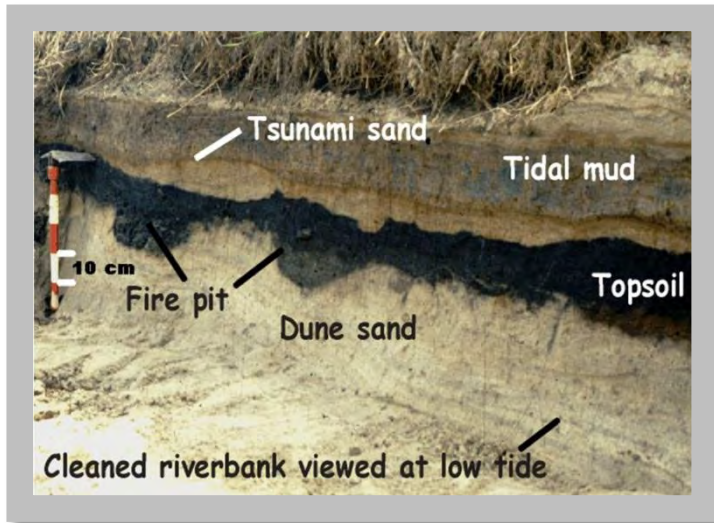

Figure 1.2: This photo (Source: Brian Atwater, USGS) shows a riverbank from the Salmon River estuary where Native American firepots were found in a forest soil that subsided in the 1700 AD earthquake and was buried by tsunami sand and tidal mud.

Geologists have assembled a ten thousand year record of past Cascadia earthquakes (see Figure 1.3) by studying sediments in coastal marshes and on the ocean floor. This record shows that past earthquakes have occurred at highly variable intervals and can range widely in size and in which parts of the Pacific Northwest they affect. About half of the past earthquakes have been very large (estimated magnitude 8.3 to 8.6) and centered on the southern Oregon coast, while the other half have been great (estimated magnitude 8.7 to 9.3) and extending from northern California to British Columbia. The most recent event occurred on January 26, 1700 AD, and was a great earthquake with a magnitude of 9.0. The time interval between previous earthquakes has varied from a few decades to many centuries, but most of the past intervals have been shorter than the 313 years since the last event. It is simply not scientifically feasible to predict, or even estimate, when the next Cascadia earthquake will occur, but the calculated odds that a Cascadia earthquake will occur in the next 50 years range from 7-15 percent for a great earthquake affecting the entire Pacific Northwest to about 37 percent for a very large earthquake affecting southern Oregon and northern California. The likelihood of a M 9 Cascadia earthquake during our lifetimes and the consequences of such an earthquake are both so great that it is prudent to consider this type of earthquake when designing new structures or retrofit of existing structures, evaluating the seismic safety of existing structures, or planning emergency response and preparedness.

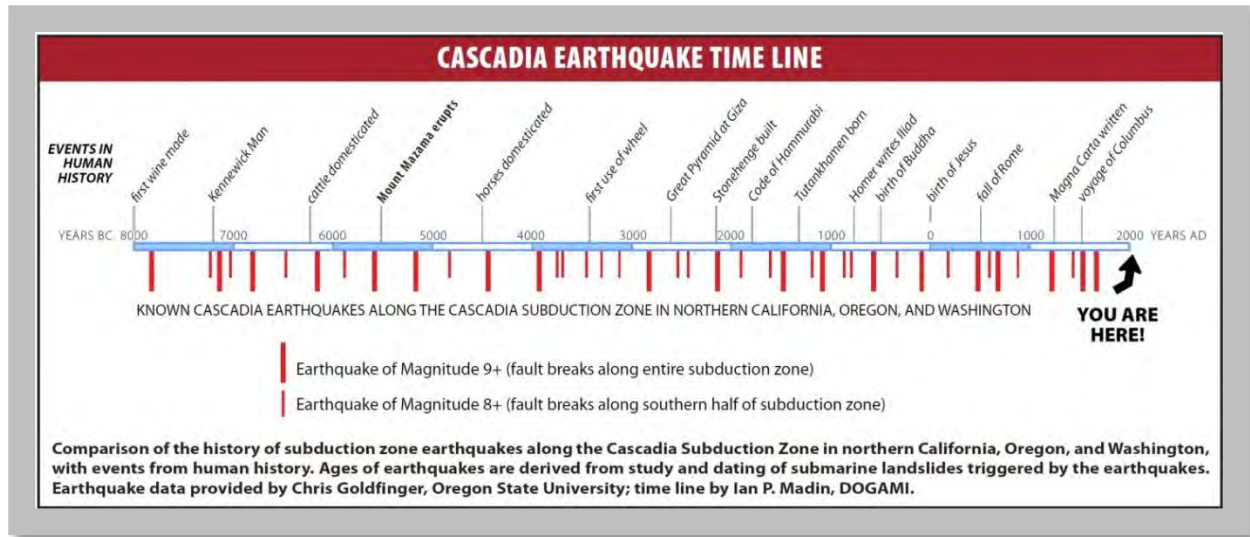

Figure 1.3: This timeline compares the 10,000-year-long history of Cascadia earthquakes to events in human history.

Resilience Plan Earthquake Scenario

For the purpose of this resilience planning effort, we chose to look at the effects of a great earthquake of magnitude 9.0, because it is a very real possibility that would affect all of Oregon and is directly comparable to the 2011 Tohoku earthquake, the effects of which are all too well known. Using the latest models from the United States Geological Survey (USGS), we simulated the strong shaking that is likely to occur during the region’s next magnitude 9.0 event. The simulated shaking map was then used to estimate the amount of ground failure due to liquefaction and landsliding that would result from such an earthquake. For the tsunami, we used a model of the inundation from a magnitude 9.0 event. This model, which was produced by the Oregon Department of Geology and Mineral Industries (DOGAMI), was applied to maps of the coast to show which areas and facilities would be inundated. The tsunami models also provided estimates of the permanent coastal subsidence that would accompany the earthquake and tsunami. These maps of simulated earthquake effects were used to evaluate the likely performance of Oregon’s critical buildings and infrastructure.

The simulation shows that Oregon would experience shaking very similar to the shaking that northern Japan endured in 2011. As indicated in Figure 1.4, areas along Oregon’s coast would experience severe to violent shaking, while cities along the I-5 corridor would experience strong or very strong shaking. East of the Cascades, shaking would be light to moderate. In all areas, the strong shaking would last from two to four minutes.

This expected pattern of damage led OSSPAC to evaluate the state in four distinct zones (see Figure 1.5):

- The Tsunami Zone, where severe shaking and tsunami inundation would cause near total damage, and threaten the lives of thousands of residents.

- The Coastal Zone, where severe shaking and damage to transportation systems would severely disrupt and isolate communities and where the major challenge after the earthquake would be to keep the population sheltered, fed and healthy.
- The Valley Zone, where widespread moderate damage would severely disrupt daily life and commerce and where restoring services to business and residents would be the main priority.
- The Eastern zone where light damage would allow rapid restoration of services and functions, and where communities would become critical hubs for the movement of response recovery and restoration personnel and materials for the rest of the state.

The results of the ground failure simulation (see Figure 1.6) suggest that large areas of western Oregon would be severely affected. Strong shaking causes ground failure in two ways. Along rivers, lakes, and the coast, where there are deposits of loose water-saturated sand, shaking causes the sand to liquefy, and the weakened soil readily settles or spreads. On steep slopes with weak soil and rock, or in areas of existing landslides, the shaking can cause new or renewed landslide movement, with very damaging results. Ground failure can cause severe damage to buildings and is particularly damaging to lifelines, which by their nature must often cross wide areas of affected ground.

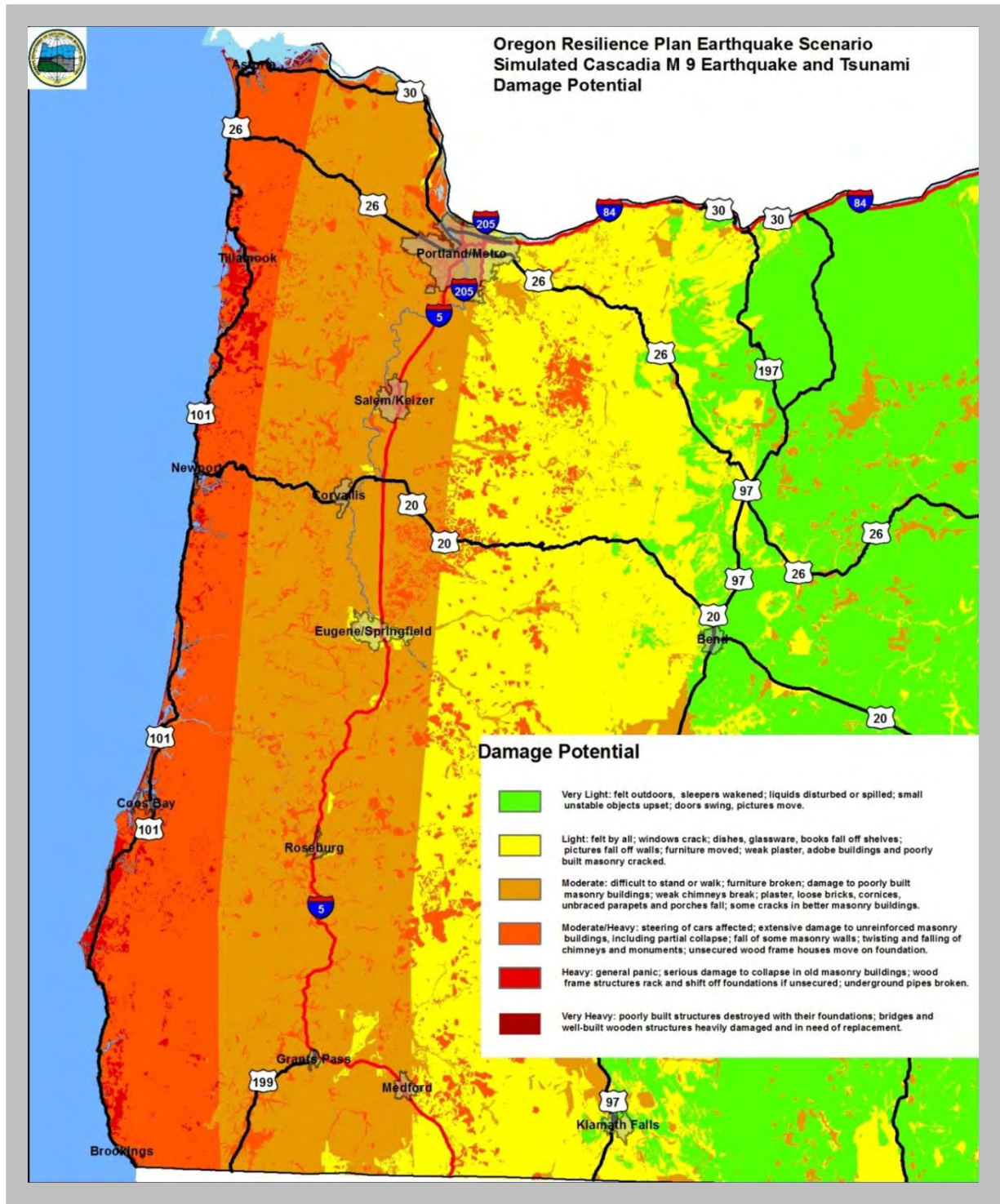

Figure 1.4: Simulated shaking for the magnitude 9.0 Cascadia scenario.

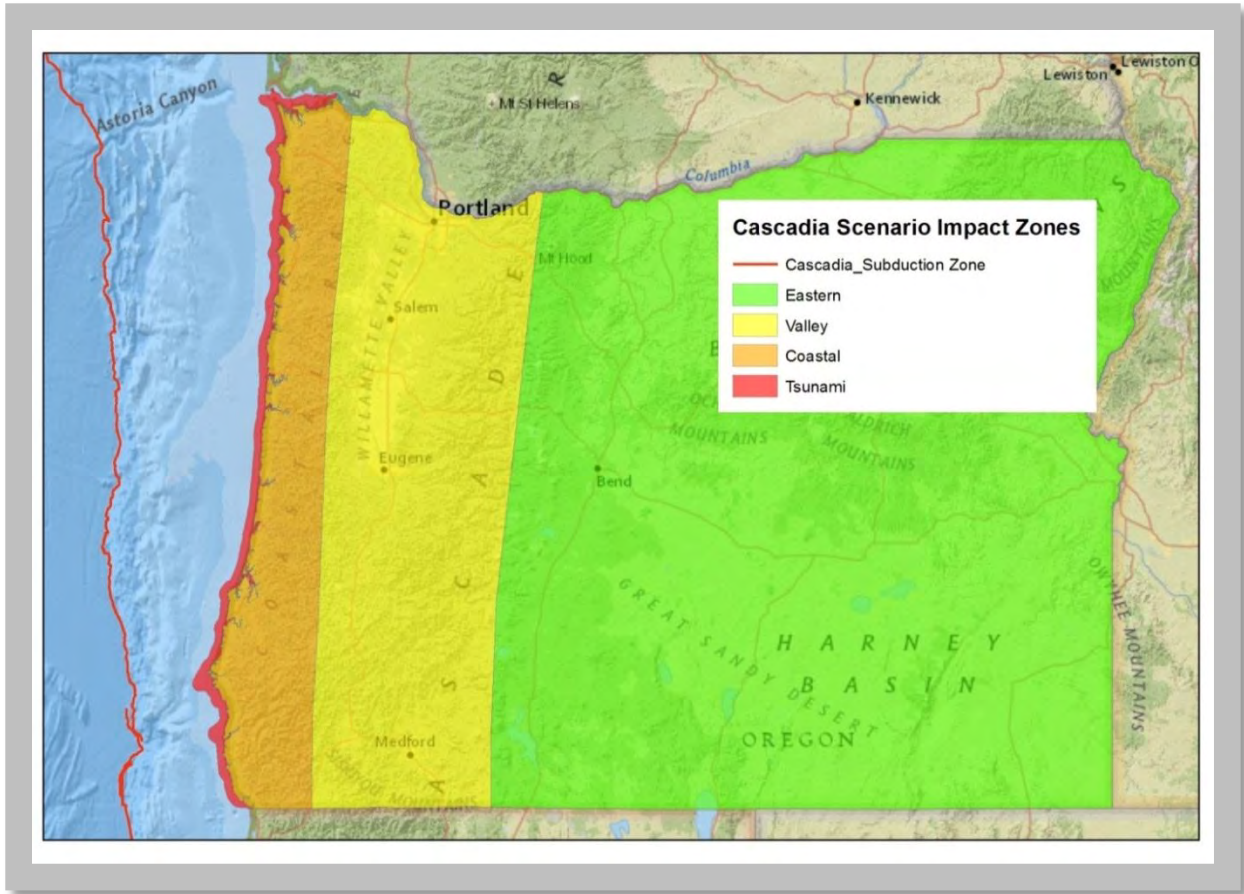

Figure 1.5: Impact zones for the magnitude 9.0 Cascadia earthquake scenario. Damage will be extreme in the Tsunami zone, heavy in the Coastal zone, moderate in the Valley zone, and light in the Eastern zone.

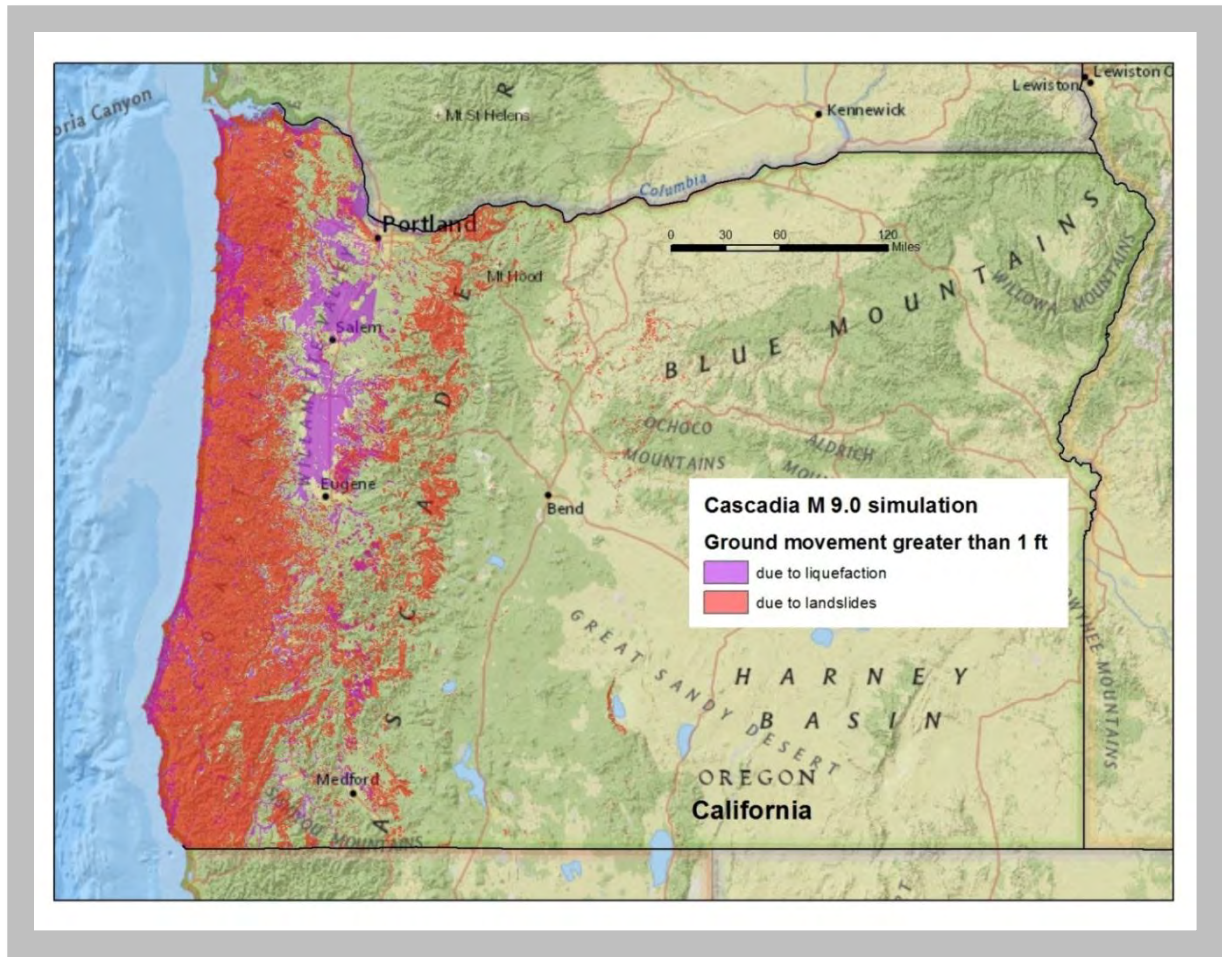

Figure 1.6: Ground failure and movement for the magnitude 9.0 Cascadia earthquake scenario. Colored areas could experience more than one foot of ground movement due to earthquake-induced landslides in steep areas and liquefaction failure in lowlands. Both forms of ground failure can cause severe damage.

The amount of tsunami inundation that would be experienced along the coast due to the scenario magnitude 9.0 earthquake is quite variable and depends on local topography. Large parts of many low-lying communities, such as Warrenton, Seaside, Rockaway Beach, and Neskowin (see Figure 1.7), will be inundated.

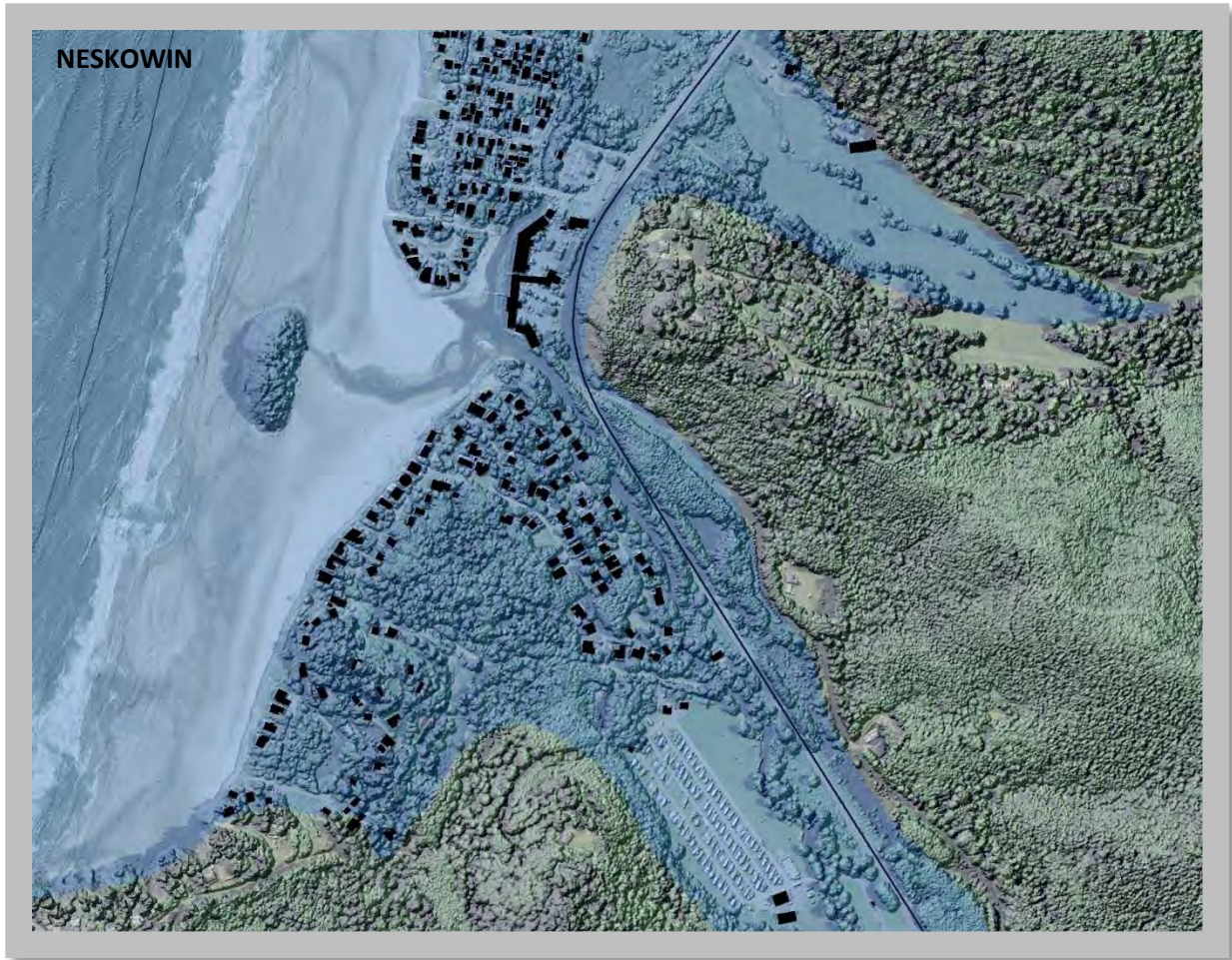

Figure 1.7: Estimated inundation of Neskowin due to the tsunami from the scenario magnitude 9.0 Cascadia earthquake. This tsunami map is based on the SB 379 regulatory inundation line.

The same large scale bending of the tectonic plates that causes the tsunami will also cause immediate and permanent subsidence in many parts of the coast. As indicated in Figure 1.8, the amount that the land will drop varies from place to place, with as much as 5 to 6 feet possible near Astoria, and even more possible at Brookings.

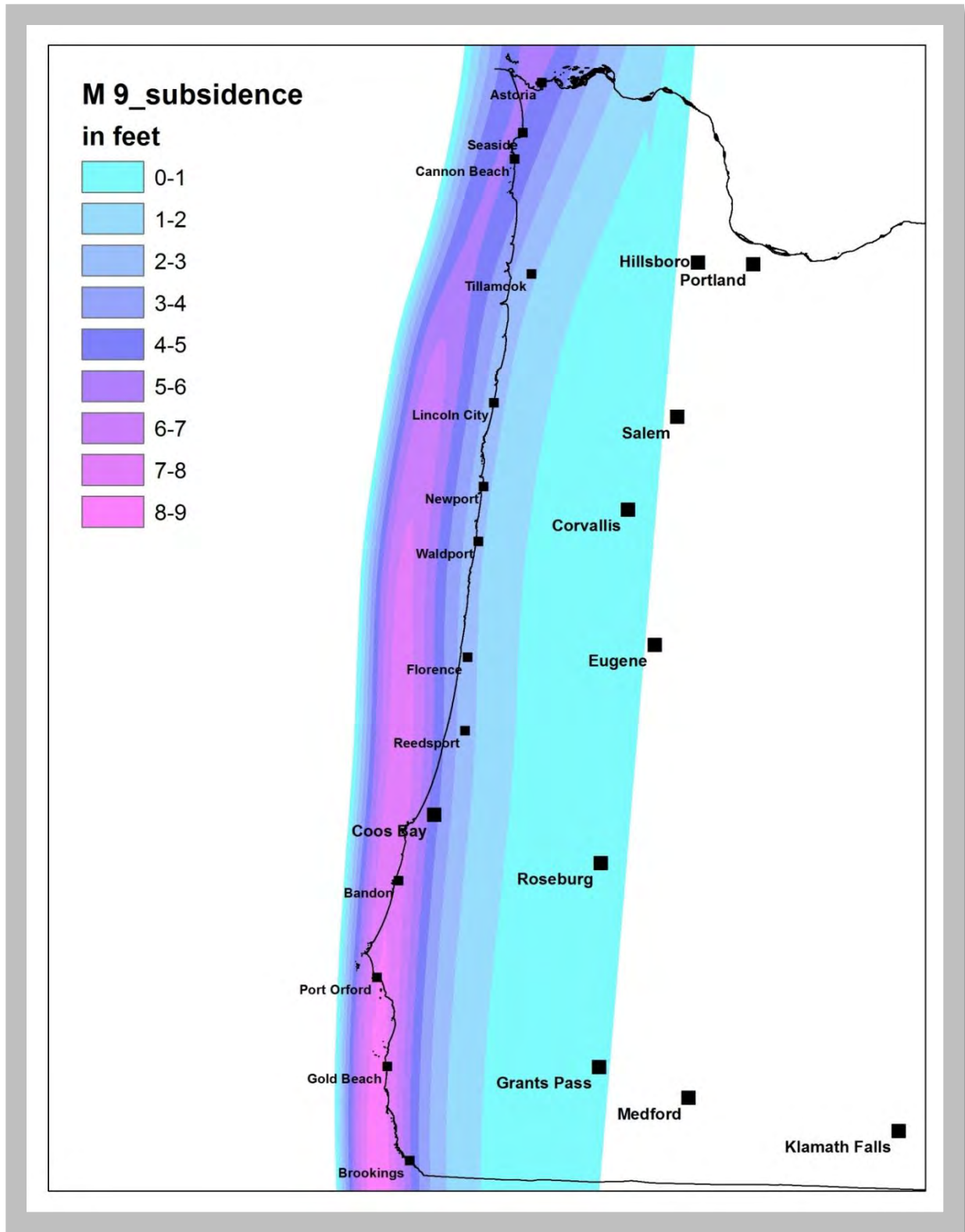

Figure 1.8: Estimated permanent land subsidence from the scenario magnitude 9.0 earthquake for the Oregon Coast. Subsidence would occur during the earthquake.

Oregon’s Infrastructure and Risk

The estimated impacts of a Cascadia subduction earthquake in Oregon are catastrophic. This is partly due to the sheer size and power of a magnitude 9.0 earthquake, but it is also the result of the inherent vulnerability of our buildings and lifelines. In 1974, Oregon adopted a statewide building code that mandated some seismic resistance for new construction. Prior to that date, the majority of buildings in Oregon had been designed without regard to earthquake forces. In 1993, Oregon’s building codes were changed to require designs that would accommodate shaking from a Cascadia subduction zone earthquake, almost doubling the earthquake forces used in earlier codes. This means that the majority of buildings in Oregon have not been designed to resist the shaking from a magnitude 9.0 Cascadia earthquake. This widespread vulnerability of Oregon’s buildings is grimly illustrated in the *Statewide Seismic Needs Assessment* completed by the Oregon Department of Geology and Mineral Industries (DOGAMI) in 2007. This study surveyed public schools and public safety buildings (police and fire stations, hospitals, and emergency operation centers) in Oregon and assessed their potential for collapse in a major earthquake. Almost half of the 2,193 public school buildings examined had a high or very high potential for collapse, as did almost a quarter of the public safety buildings. Of the 2,567 highway bridges in the Oregon Department of Transportation (ODOT) system, 982 were built without seismic considerations, and of the rest, only 409 were designed specifically with consideration of Cascadia subduction zone earthquakes. The list goes on: old, brittle iron water pipes in the Portland water system, century-old bridges over the Willamette River, and highways and power transmission lines that traverse landslide-prone terrain. The core of our vulnerability to a Cascadia earthquake is not the earthquake alone, but the inadequacy of our built environment.

The experience of the Tohoku earthquake shows that few structures are likely to survive in the tsunami inundation zone. In Oregon, the USGS estimates that almost 1,900 businesses employing nearly 15,000 people are located in the scenario inundation zone. The inundation zone also contains almost 10,500 housing units with a total population of just over 22,000. This exposure to the extreme hazard posed by the tsunami is unavoidable.

Another major factor that amplifies the effects of a Cascadia earthquake is the interdependency of our lifeline systems, coupled with the wide geographic spread of a Cascadia disaster. Unlike a severe storm, a Cascadia subduction earthquake would simultaneously damage power, natural gas, and petroleum lines, roads and bridges, water and sewer systems, critical buildings, and communications over large parts of three states (i.e., California, Oregon and Washington). Restoration of communication service would require that electric power be restored, which would require that roads and bridges be repaired, which in turn would require that the petroleum delivery and distribution system be repaired. These interdependencies between lifeline systems would be made even more difficult by the broad geographic extent of the damage. The nearest undamaged urban areas from which assistance could be organized would be Spokane, Washington, Boise, Idaho, and Redding, California. Virtually all of the resources required for the recovery of lifeline systems would have to come from outside the affected states.

Estimated Impacts

The scenario Cascadia earthquake would be an unprecedented catastrophe for Oregon and for the United States. It would impact every aspect of life for all Oregonians and for the residents of northern California, Washington, and British Columbia. The effects of a Cascadia subduction earthquake will be greatest on the coast, which is right next to the subduction zone fault, and will diminish as one goes inland. This, in combination with Oregon’s mountainous geography, divides the state into four impact zones: within the tsunami zone, damage will be nearly complete. In the coastal zone, shaking will be severe, liquefaction and landsliding will be widespread and severe, and damage will be severe. In the valley zone, shaking will be strong, liquefaction and landsliding will be common but less severe, and moderate damage will be widespread. In the eastern zone, shaking will be mild, landslides and liquefaction sporadic, and damage generally light.

The impacts of a great subduction earthquake on Oregon are impossible to predict accurately, but several studies have estimated damage and casualties, and those estimates give a sense for how far-reaching a disaster the next great earthquake will be. Estimated consequences include:

- Earthquake deaths ranging from 650 to 5,000, with another 600 to 5,000 deaths due to the tsunami.
- 24,000 buildings completely destroyed, and another 85,000 with extensive damage requiring months to years of repair.
- Approximately \$32 billion in economic losses.
- 27,600 displaced households.
- Almost 10 million tons of debris (1 million dump truck loads).

These high levels of damage and loss reflect both the great size of the earthquake and the fact that many buildings, roads, bridges, and utility networks were designed before Oregon’s building codes and practices recognized any significant earthquake threats, and most were designed before codes began to take great subduction earthquakes into account. Lifeline systems, such as highways and pipelines, are particularly vulnerable to ground failure, which will be widespread in the next great earthquake. As a result, the vulnerability analyses done for this plan are grim. For example, if the earthquake were to happen tomorrow, the estimated time to restore function would be:

- One to three years to restore drinking water and sewer service in the coastal zone.
- One month to one year to restore water and sewer in the valley zone.
- Six to twelve months to restore partial function of the top-priority highways in the valley zone.
- Two to four months to restore police and fire stations in the valley zone.
- Eighteen months to restore healthcare facilities in the valley zone, three years or more in the coastal zone.

- One to three months to restore electricity service in the valley zone.
- Three to six months to restore electricity service in the coastal zone.

These estimates of the time it will take to restore the functions necessary to maintain our population and economy are sobering, particularly when coupled with the likelihood that businesses will start to leave the state if services are not restored within one month. If we pursue a policy of “business as usual,” our future after the next Cascadia earthquake will include decades-worth of declining economy and population. We can only avoid this future and achieve resilience by starting now on a sustained program to reduce our vulnerability and decrease our recovery time before the next earthquake inevitably occurs.



Recommendations

The Cascadia Scenario workgroup prepared a description of the likely effects of a magnitude 9 subduction earthquake for the other workgroups to use in their evaluations. The scenario used the best currently available data, and well-established methods, but still provides an estimate that has a lot of uncertainty and little detail. For an improved understanding of the threat posed by Cascadia earthquakes, we recommend that the state:

- ▶ Support Oregon universities and state agencies to carry out research into the effects of future Cascadia subduction earthquakes and tsunamis on Oregon's landscape, population, buildings and lifelines;
- ▶ Support Oregon universities and state agencies in preparing more detailed and accurate estimates of damage and loss in Oregon from future Cascadia subduction earthquakes and tsunamis; and
- ▶ Provide ready access to the best available Cascadia earthquake information for emergency responders and planners, architects and engineers, and the general public.
- ▶ In order to ensure that design of future structures, retrofit of existing structures, seismic vulnerability evaluations and preparedness planning will provide adequate resilience, we also recommend that all of these efforts use, as a minimum, the ground motion parameters provided by the most current version of the International Building Code, which reflect the most current USGS seismic hazard maps.

Reference

1. DOGAMI (2007), *Statewide Seismic Needs Assessment Using Rapid Visual Screening (RVS)*. For detailed information, see <http://www.oregongeology.com/sub/projects/rvs/default.htm#overview>
2. Oregon Department of Transportation (2009), *Seismic Vulnerability of Oregon State Highway Bridges: Mitigation Strategies to Reduce Major Mobility Risks*. For detailed information, see ftp://ftp.odot.state.or.us/Bridge/bridge_website_chittirat/2009_Seismic_Vulnerability_final.pdf.
3. SPUR (2009). *The Resilient City: Defining What San Francisco Needs from Seismic Mitigation Policies*. For detailed information, see <http://www.spur.org/initiative/resilient-city>
4. Washington Seismic Safety Committee (2012). *Resilient Washington State: A Framework for Minimizing Loss and Improving Statewide Recovery after an Earthquake*. November. See <http://www.emd.wa.gov/about/SeismicSafetyCommittee.shtml>

2. Business and Workforce Continuity

Introduction

We know from experience of previous disasters such as hurricanes and earthquakes that a large proportion of the businesses affected by these natural cataclysms will not survive. Nevertheless, it is our mission to make Oregon's businesses and workforce more resilient against the threat posed by a megathrust Cascadia earthquake. The key to business survivability begins with the survivability of the buildings that house the businesses (see Figure 2.1). Few businesses can survive without a domicile for more than a month. Experience tells us that if a business cannot reoccupy its offices within a month, it will either relocate, or dissolve.

Reoccupation of a business's workspace depends on three principal factors: the building's structure must be safe; the workforce must be able to get to the workplace; and, the building's mechanical and utility systems must be up and running. In addition, it is essential that the business's customers survive the catastrophe. This is of particular concern when a business's customers are other businesses that may be housed in buildings that do not survive. A 2011 Cascadia earthquake study by the Federal Emergency Management Agency estimated that only about 20 percent of the buildings in the Metro Region would escape damage, while 80 percent would suffer damage ranging from slight damage to a complete loss (see Figure 2.2).

Statewide, about 27 percent of commercial buildings would survive without damage and about 22 percent would suffer slight damage. The remaining buildings, which would suffer moderate (31%) or extensive (16%) damage, or be completely destroyed (4%), will not be immediately inhabitable for commercial purposes.



Figure 2.1: Windham, N.Y., September 1, 2011 -- A shop on Main Street in Windham proclaims their victory over the destruction from Hurricane Irene. The town suffered damage to homes and businesses and was included in the disaster declaration by President Obama on 9/3/11. (Source: FEMA Photo/Judith Grafe)

Commercial	None	Slight	Moderate	Extensive	Complete	Total
Metro Region	6,759	10,106	12,270	4,647	461	34,242
Outside Metro	14,333	7,596	11,878	7,904	3,072	44,785
Total	21,092	17,702	24,148	12,551	3,533	79,027

Figure 2.2: Analytical Baseline Study for the Cascadia Earthquake and Tsunami (Source: FEMA, November 18, 2011)

Evaluation of the Scenario Earthquake's Economic Impact

A magnitude 9.0 Cascadia subduction earthquake has the potential to inflict tens (and maybe even hundreds) of billions of dollars in damage to existing property and infrastructure, but the costs of the event are not limited to these billions of dollars in replacement costs. While damaged infrastructure is removed, repaired, or replaced, normal economic activity will be interrupted. Some firms may be forced to shut down or move. Some people may migrate out of the state. These spillover disruptions may permanently change the trajectory of the regional economy, imposing damages that dwarf those inflicted directly by the event.

Preparing now and creating a more resilient Oregon is essential to reducing these costs and preserving the health of our communities and our economy. Resilience will reduce the deaths and injuries that such an event will inevitably cause. Resilience will minimize the damage to our homes and office buildings, to our roads and bridges, to our energy and telecommunications transmission systems, and to our water and wastewater systems. In short, resilience will minimize the disruptions to our economy, our community, and ourselves.

Every large natural disaster is unpredictable, not only in its timing, but in its effects. We cannot say precisely how large the damages associated with a Cascadia event will be, nor forecast in detail what will be damaged, nor foresee how the loss of buildings, roads, utility infrastructure, and other elements will ripple through the economy. As best, we can draw on economic theory and the experiences from previous disasters to assess the potential effects of such an event.

HOW DO NATURAL DISASTERS AFFECT REGIONAL ECONOMIES?

Fundamentally, natural disasters break things. They break houses and buildings. They break roads and bridges. They break pipelines and transmission lines. They break water pipes and treatment plants. When things break, people and the economy suffer.

Direct Damage

What disasters break is expensive to repair. Economists use the term *direct damage* to refer to damage that disasters inflict on buildings, infrastructure, inventories, natural resources, and people (Pelling, Oezerdem, and Barakat, 2002). When news articles report that a disaster inflicted \$300 billion in damages, they are reporting an estimate of the direct damage inflicted by the event. They are reporting the expected amount of money needed to replace what has been lost.

Indirect Damage

When things break, they can no longer be used to support economic activity. If key port infrastructure breaks, the port must shut down. If a bridge breaks, workers may not be able to get to work and firms may not be able to ship or receive goods. If the internet or telecommunications networks fail, firms may lose customers. If oil spills into rivers, river dependent industries, such as fishing or recreation, may be disrupted. Economists use the term *indirect damage* to refer to the loss of economic activity that results from the inability to use what breaks (Pelling, Oezerdem, and Barakat, 2002).



Figure 2.3: Branford, Conn., August 31, 2011 -- A gas station on Route 95 is closed due to loss of power from Hurricane Irene. (Source: Jocelyn Augustino/FEMA)

Thus, the benefits of greater resilience can be assessed along two lines: First, greater resilience means fewer things break, so Oregonians will need to spend less money on cleaning up, repairing, or replacing

what has been lost. Second, when fewer things break, there is less potential for extensive interruption of the economy (see Figure 2.3).

GREATER RESILIENCE MEANS LESS DIRECT DAMAGE FROM THE EVENT

Spending on resilience today means spending less on recovery later. For an event as large as a magnitude 9.0 Cascadia subduction zone earthquake, such avoided costs may be substantial. For instance, the recent earthquake in Sendai, Japan inflicted approximately \$300 billion in damage, the 1995 Kobe earthquake inflicted \$200 billion in damage, hurricane Katrina inflicted approximately \$160 billion in damage, and the 1994 Northridge earthquake inflicted nearly \$100 billion in damage (see *The Economist* online, 2011. “Natural Disasters: Counting the Costs”). For context, Katrina’s direct damages equaled nearly two-thirds of total personal income in Louisiana and Mississippi in 2006 and the Northridge quake inflicted damages equal to approximately 25 percent of the Los Angeles metro area’s personal income in 1994 (US Bureau of Economic Analysis, Regional Economic Accounts). By extension, if a Cascadia earthquake only inflicts damage proportionate to Hurricane Katrina, it might cost Oregon approximately \$100 billion to repair what was lost.¹

Ultimately, we cannot know precisely how much damage an earthquake in Oregon will inflict. The precise amount of initial damage will depend on the magnitude of the earthquake, the value of property and infrastructure in Oregon, and what we do to protect our property and infrastructure before the event occurs. We do know that recovery is unlikely to come cheaply.

While some (and hopefully much) of the money required to fund recovery will come from outside the region (for example, from insurance payments or the federal government), recovery will still require substantial local resources from both the private and public sectors. Money spent repairing something the region already had is money that cannot be spent pursuing other priorities. Furthermore, some of what Oregon will lose to the earthquake cannot be replaced. The direct damage estimates described above do not include damages to human health and other hard-to-value items, such as historical or culturally significant items.

GREATER RESILIENCE MEANS FEWER INTERRUPTIONS OF NORMAL ECONOMIC ACTIVITY

Disasters Depress Normal Economic Activity

Ultimately, the direct costs of a Cascadia subduction zone earthquake are likely to pale in comparison to the indirect costs. The interruption of normal economic activity could generate costs so substantial that the region may never fully recover.

In 2011, Oregon’s economy produced nearly \$195 billion in goods and services (US Bureau of Economic Analysis, Regional Economic Accounts). The state’s firms and agencies employed over 2.2 million people who earned over \$104 billion in compensation (Bureau of Economic Analysis, Regional Economic Accounts). While these workers produced goods and services in a wide variety of industries (including

¹ Oregon’s 2011 total personal income was \$145 billion.

agriculture, logging, wood products manufacturing, computer and electronics manufacturing, metals manufacturing, company management, and tourism), every industry depends on various factors that could be disrupted by a Cascadia event.

For a regional economy to operate smoothly, several conditions must be met:

- (1) Raw materials (food, water, energy, information, and other commodities) and imported goods and services must be available and able to reach households and firms.
- (2) Households must be able to provide workers to firms (and government) and they must be able to consume the goods and services that are made available by local producers. In other words, households must have their basic needs satisfied, and they must have the resources to consume.
- (3) Firms must be able to combine raw materials, workers, and equipment to transform the available inputs into finished products.
- (4) Finished products must be available to customers, inside and outside of the region.

These basic relationships are illustrated in Figure 2.4; however, a severe natural disaster would likely affect each of these areas and break the key infrastructure that connects them. For example, a severe natural disaster could:

- (1) Directly damage raw materials or inventories of imported goods.
- (2) Damage the roads, bridges, pipes, or utility lines used to transport such goods to households and firms.
- (3) Damage houses and households and limit both their ability to provide workers to firms and their ability to consume goods and services produced by local firms.
- (4) Damage the buildings and equipment owned by firms, making production impossible.
- (5) Damage the infrastructure used to transport finished products to customers (households or other firms).

If any of these (or many other possible) impacts occur, Oregon's economic output will suffer. Oregon's employers simply cannot produce and sell their goods and services if they lack the space in which to carry out production, if inputs cannot reach them, or if their outputs cannot get to their customers. When firms cannot produce and sell their goods and services, they stop contributing to the regional economy, and they may be unable to survive if the interruption lasts too long.

Firms may also struggle due to disruptions in consumption. Seventy percent of Oregon's workers work in industries that primarily serve customers in Oregon (that is, they work in the local as opposed to the traded sector). (For additional information about the distinctions between the traded and local sectors,

see Ward, Thoma, Moore, and Tapogna, 2012). Local sector firms will suffer if Oregonians (both households and firms) do not have money to spend, either because they have lost their sources of income or because they are spending their incomes on repairing or replacing what was lost. Local sector firms could also suffer if people or firms chose to leave the region entirely. Thus, even if local sector workers and firms are fully capable of continuing to produce, they could suffer because their customers have disappeared.

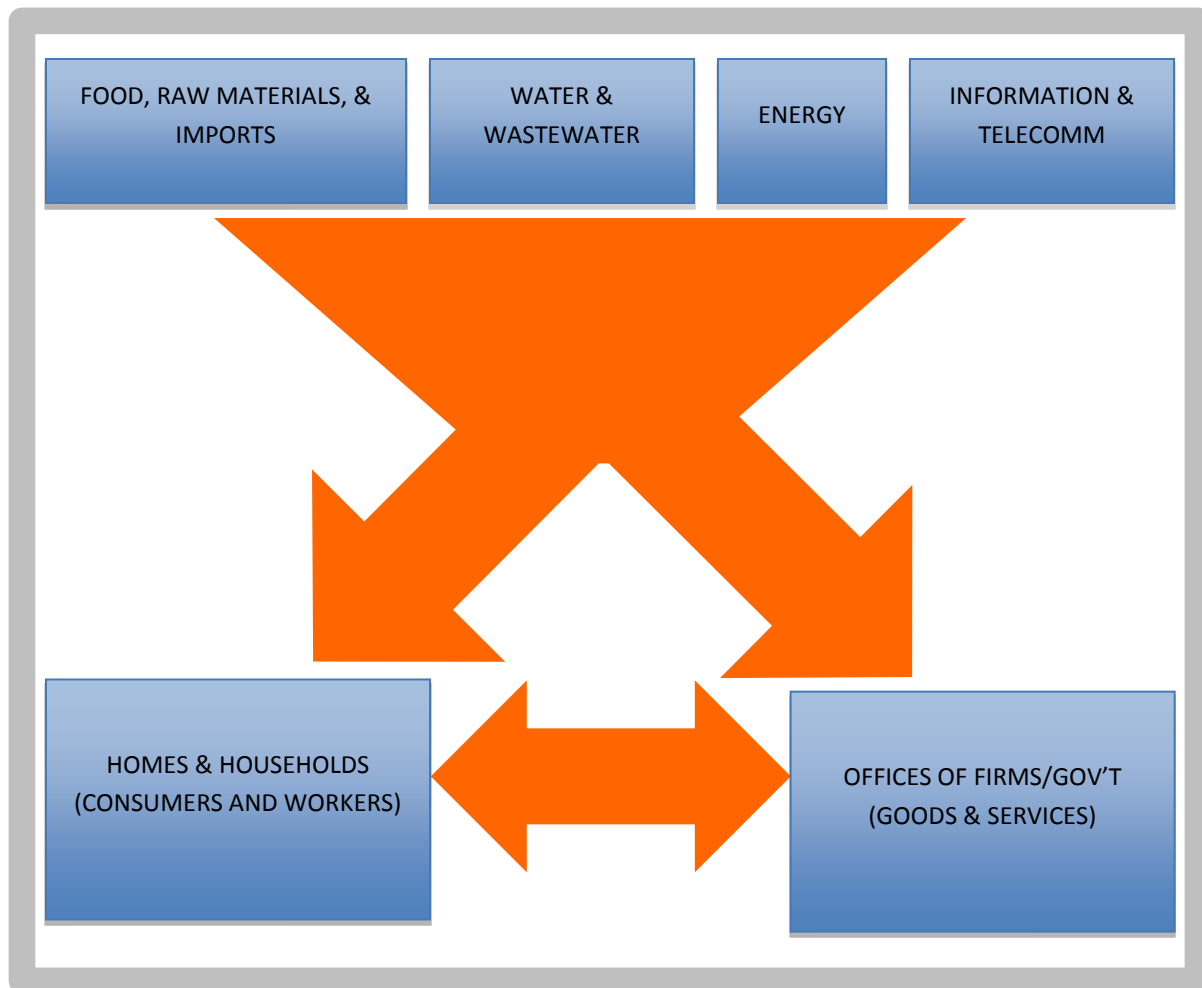

Figure 2.4: Core Economic Relationships That May Be Affected By Natural Disasters

A Disaster’s Indirect Effects Are Felt over Both the Short and the Long Run

When people imagine the economic effects of a natural disaster, they typically imagine the disruptions that occur in the immediate aftermath of the event. Economists refer to these initial disruptions as the

short-run effects of the disaster² (Cavallo and Noy, 2010). During this period (which may last a few years), normal economic activity may be severely inhibited as resources are diverted toward cleanup and recovery efforts. The literature that examines the short-run effects of natural disasters finds that the event will depress economic outcomes for a few years, but that areas with “a better educated population, better governance, and more direct access to reconstruction resources will fare better in the disaster’s aftermath” (see Noy, 2011).

Unfortunately, the effects of a natural disaster may not be limited to the time it takes to clean up and rebuild. Disasters may permanently shift the trajectory of the economy. In other words, the disaster may have long-run effects.³

Some economists argue that economies are resilient and generally return to “as before” conditions within a few years⁴ (see DuPont and Noy, 2012). However, recent evidence suggests that disasters may have larger long-run consequences than previously thought (see DuPont and Noy, 2012; Lynham, Noy, and Page, 2012; and Coffman and Noy, 2012). Specifically, economist Ilan Noy and various co-authors have examined the long-run regional effects of the 1995 Kobe earthquake, the 1960 tsunami in Hilo, Hawaii, and the 1992 hurricane in Kauai, Hawaii (DuPont and Noy, 2012; Coffman and Noy, 2012; Lynham, Noy, and Page, 2012). In each case, these studies found that the disaster caused outcomes to deteriorate from what they likely would have been in the absence of the disaster; however, how the disaster adversely affected long-run outcomes differs across these three events.

Kobe (DuPont and Noy, 2012): The Kobe earthquake inflicted nearly \$200 billion in damage (in 2010 dollars). The quake severely damaged Kobe’s port—a significant source of local economic activity—as well as 80 percent of its shoe factories, 50 percent of its sake breweries, and half of its markets. While many sectors recovered to pre-earthquake levels, several sectors of Kobe’s economy remain significantly below these levels. Port capacity recovered to 98 percent of pre-earthquake levels, but the number of ships handled peaked at 87.7 percent of pre-earthquake levels. Mining and manufacturing activity has only reached 81.3 percent of pre-earthquake levels. Shoe production remains at 60 percent of pre-earthquake levels. Sake breweries ship less than 50 percent of their pre-earthquake levels. Department store sales remain at only 75 percent of pre-earthquake levels.

While such changes could reflect other trends and not the influence of the earthquake, a careful analysis, which compared Kobe and its surrounding areas to parts of Japan not severely affected by the earthquake – finds evidence that the earthquake had lasting effects on local output. While output per

² The short run effects are generally those that occur within the first three years of the event, and long run effects are generally those occurring beyond five years.

³ Economic theory does not provide a clear expectation for the direction or magnitude of long run effects. Cavallo et al. (2010) summarize the competing theories.

⁴ This position was effectively summarized by John Stuart Mill in 1872 when he stated, “...what has so often excited wonder, the great rapidity with which countries recover from a state of devastation; the disappearance, in a short time, of all traces of the mischiefs done by earthquakes, floods, hurricanes, and the ravages of war. An enemy lays waste to a country . . . and yet in a few years after, everything is much as it was before.”(Mill, 1872). Many economists espoused similar sentiments in the wake of the recent 2010 Tohoku earthquake.

capita initially spiked with recovery efforts, it fell as recovery efforts waned. In 2010, output per person was 13 percent lower than it likely would have been in the absence of the earthquake. For context, if Oregon were to experience a 13 percent decline in output per capita, output would fall by over \$6,200 per person, and Oregon's output per capita would fall from 9th to 23rd among all states.

Hilo (Lynham, Noy, and Page, 2012): In 1960, a tsunami generated by the magnitude 9.5 Valdivia earthquake in Chile (the largest earthquake ever recorded) struck Hilo, Hawaii. This tsunami killed 61 people and inundated 600 acres, completely destroying half of the buildings in the inundation zone. An analysis that compared the affected area to other Hawaiian islands that were not significantly affected by the tsunami found that, 15 years after the event, Hilo was short of people, firms, and jobs.

Fifteen years after the tsunami, Hilo's population was nine percent below the levels it likely would have achieved in the absence of the tsunami. The total number of establishments remained depressed and unemployment remained elevated—33 percent higher than expected. Finally, sugar, the island's most important industry, remained depressed following the tsunami.

Kauai (Coffman and Noy, 2012): In 1992, Hurricane Iniki struck Kauai (but largely missed the other Hawaiian islands). While the hurricane did not cause significant mortality, it did severely damage local infrastructure. The loss of infrastructure appears to have had significant long-term consequences. Twenty years after the event, population and employment on Kauai remain well below (15 percent) the levels expected in the absence of the hurricane.

Combined, these three studies suggest that disasters can substantially disrupt long-run economic performance. Thus, greater resilience may help Oregon avoid large long-run consequences such as severe losses to output per capita (such as occurred in Kobe) or population and employment (such as occurred in Hilo and Kauai). This is not inconsistent with how regional economists expect regions to respond to non-natural economic disasters. Frequently, when regional economies suffer adverse regional shocks, the economy shrinks and then grows from the new lower base at the same rate as before—never catching up to where it would have been in the absence of the shock (Blanchard, Katz, Hall, and Eichengreen, 1992).



Figure 2.5: Carrollton, New Orleans, LA, 9-17-05 -- Small business owners are planning on returning to New Orleans. After three weeks many areas are still without power and utilities. (Source: MARVIN NAUMAN/FEMA photo)

Natural Disasters Do Not Uniformly Affect Residents

The above discussion focuses on the effects of natural disasters on aggregate measures of economic activity (such as output per capita) but ignores potentially important distributional consequences of disasters. Even if the disaster produced no adverse effect on aggregate outcomes, the avoided distributional effects may be sufficient to justify investments in greater resilience. Disasters affect incumbent residents and they are the ones whose homes are damaged, whose jobs may be lost, and whose businesses may close. Even if the economy recovers, those who benefit from the recovery may be different from those who lost during the destruction. Evidence shows that poorer residents are particularly likely to suffer following a natural disaster because they lack access to resources to help them absorb the adverse shock (Sawada and Shimizutani, 2008).

RESILIENCE AND REGIONAL ECONOMIES

In sum, greater resilience may benefit Oregonians in three major ways. First, greater resilience means less stuff will break, so Oregonians will spend less money later removing, repairing, or replacing items damaged by the event. Second, less breakage means smaller interruptions to normal economic activities in both the short and long run. Finally, greater resilience means fewer losses to the incumbent residents—particularly the poor who suffer the most when disasters strike.

While we cannot say with certainty how large such benefits may be, experiences with previous disasters suggest that the adverse consequences of disasters (and thus the benefits of greater resilience) may be large. Direct damages may reach into the hundreds of billions of dollars (amounts equal to half or more of Oregon’s annual output). If damages are similar in magnitude to those inflicted by Hurricane Katrina, Oregonians will need to work for almost a year (at normal levels) to replace what the disaster destroys. Indirect damages are very difficult to estimate. When the disaster breaks things, what is broken can no longer be used to support the economy. As a result, the damage inflicted by the disaster may ripple through the economy reducing population, output, income, and employment over both the short and long run (Figure 2.5). Several recent case studies suggest that, in the 15 years following a major disaster, outcomes (population, employment, or income) fall 10-15 percent below levels they might otherwise have reached in the absence of the disaster.

Business Workforce Interdependency

Businesses and the business workforce do not exist in a vacuum. Without a government and a system of laws and enforcement of commercial instruments (such as contracts), a strong banking system to provide access to capital, and a transportation network to bring in and distribute raw materials and manufactured goods, businesses cannot thrive. Even businesses whose products are “intellectual capital,” such as consultants, and personal services companies such as barbers or physical therapists, require strong information, communications, and municipal utility infrastructure to function successfully.

Figure 2.6 depicts some of the interdependencies of business, government, the public (both workforce and customers), banking, transportation, public and private infrastructure, and the healthcare sector. This figure is specifically intended to reflect the relationships following a major catastrophe and to serve as a guide for recovery. With the possible exception of the healthcare sector, the relationships depicted are also applicable to the interdependency of everyday commerce. The one notable omission is the education sector, which is a subset of both government (public schools) and business (private schools). Schools are likely to become major refugee and triage centers in the immediate aftermath of a Cascadia earthquake and tsunami, but from the standpoint of business recovery, schools are primarily important as a place where workers’ children can spend their days, thus freeing up parents to return to work.

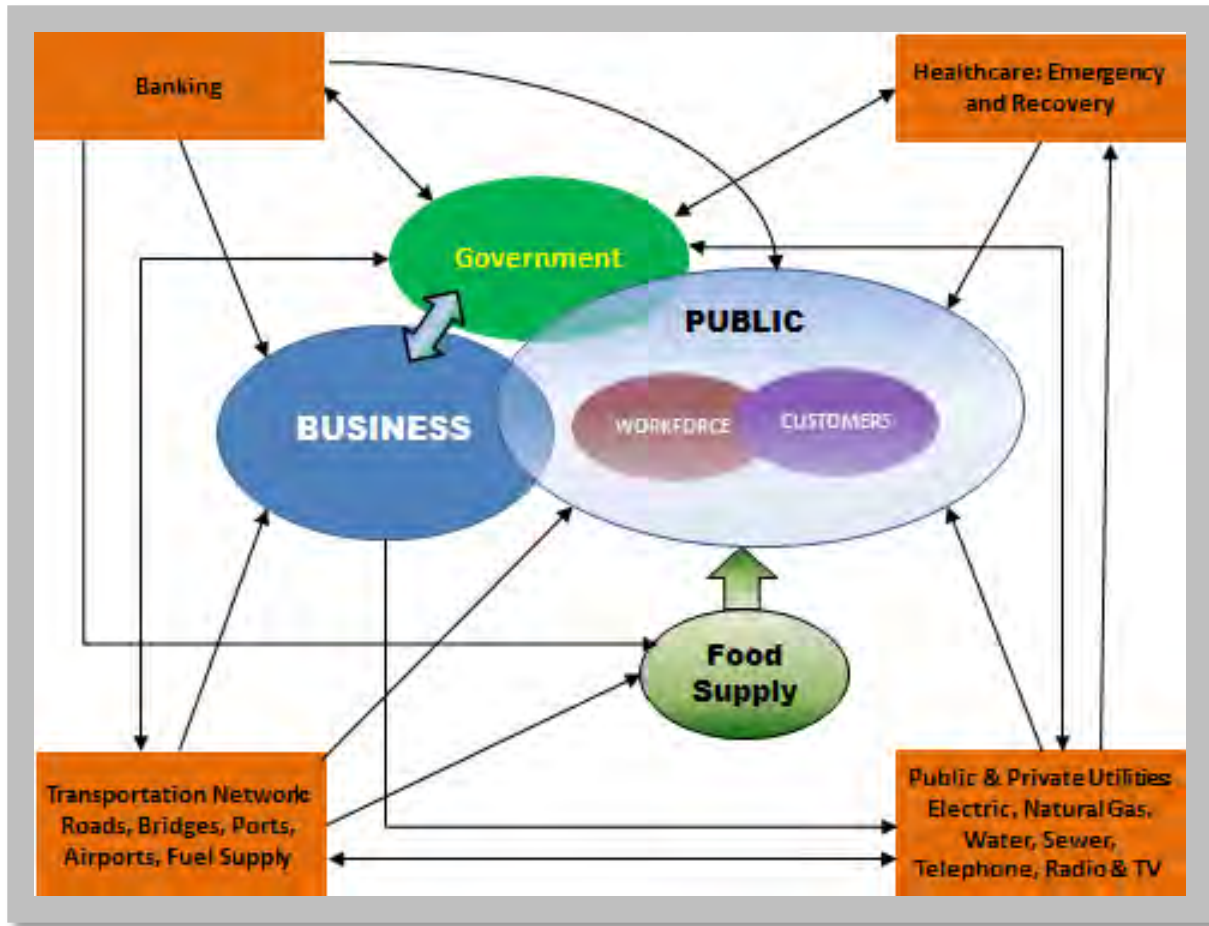

Figure 2.6: Business Workforce Interdependency

Some relationships, such as business interdependency with the healthcare sector are imputed through the business/workforce/public-to-healthcare relationship. In other words, to the extent that businesses rely on a healthy workforce and customers, who in turn rely on the healthcare sector for health-related services, the business sector relies on the healthcare sector through a sort of transitive property.



Recommendations

- ▶ **Rehabilitate or Replace vulnerable Oregon public schools**
 - *Finding:* The Department of Geology and Mineral Industries 2007 report assessed more than 1,100 public education buildings in Oregon at a high or very high risk of collapse in a major seismic event. Parents cannot return to work after a major seismic event if their children are unable to attend school.

- *Action Needed:* The State of Oregon shall establish (in addition to the General Obligation bond-funded Seismic Rehabilitation Grants Program) a statewide sinking or reserve fund, outside of the Oregon Emergency Management department budget, to fully fund the Seismic Rehabilitation Grant Program for public education facilities.

GOVERNMENT

Government, in addition to enforcing contracts and other commercial instruments, also provides security so that businesses can operate free from fear of being looted or robbed. Government’s security mission also extends to the public (see Figure 2.7). In the aftermath of Hurricane Katrina, looting of non-essential⁵ items by some members of the public was well documented. Some shop owners resorted to defending their property with personal firearms. Similar acts were documented when Hurricane Andrew devastated South Florida in 1992 and caused some homeowners to be without power for weeks.⁶

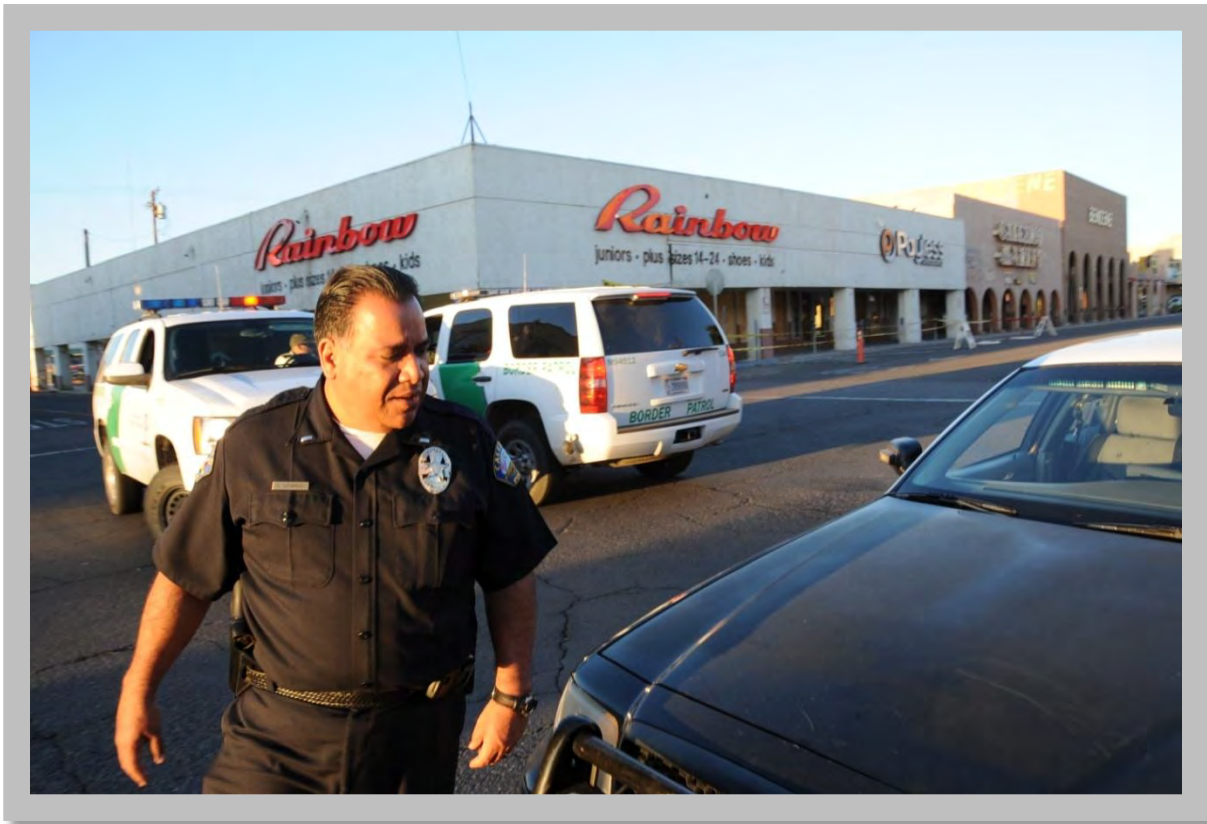

Figure 2.7: Calexico, Calif., April 6, 2010 -- Calexico Police Lt. Gonzalo Gerrado and US Border Patrol agents patrol the damaged businesses and public facilities to mitigate looting and theft. A magnitude 7.2 earthquake rocked the city on Easter leaving many facilities, roads, and public buildings closed, broken, and exposed. (Source: Adam DuBrowa/FEMA)

⁵ By “non-essential” we mean non-food, or non-food preparation items such as gas or charcoal grilles, fuel, and so on. Looting of entertainment devices, such as TV’s and X-Boxes, furniture, and so on were well documented, as was the lack of police presence in the immediate aftermath of the hurricane.

⁶ Within Miami-Dade County more than 25,500 homes were actually destroyed and another 100,000 plus were damaged.

Hurricane damage and devastation differs from the expected impacts of a Cascadia subduction zone earthquake in that much of the damage resulting from hurricanes such as Katrina and Andrew is to smaller wood frame buildings, a type of construction typically used for single-family homes. After Katrina, for example, much of the central business core of New Orleans either survived or was quickly re-inhabitable, but much of the housing stock was destroyed. Similarly, Hurricane Andrew destroyed 63,000 homes leaving 175,000 to 250,000 people homeless (Dorschner 1992). We expect most wood-frame homes to survive a Cascadia earthquake, but we expect power and the other private and public utilities to be down in some neighborhoods for several weeks or months.

Security in the central business districts of the state is likely to be more easily accomplished than in some residential neighborhoods. The main commercial areas of the state – Portland, Eugene-Springfield, Salem, and to some extent, Albany, Corvallis, Grants Pass, and Medford – are relatively small compared to the residential areas of the cities and their suburbs. For example, in the City of Portland, the downtown commercial core⁷ makes up less than seven tenths of one percent of Portland’s 145.4 square miles (376.6 square KM) of area. The remaining area is largely residential neighborhoods, local or neighborhood commercial areas⁸, parks and industrial areas (principally in northwest, north and northeast Portland). Keeping the neighborhoods secure is expected to be a major challenge for the Portland Police Bureau and, more likely than not, National Guard troops.

Continuity of government following a Cascadia event will depend on the immediate functionality of critical and essential facilities, such as police, fire, emergency operations and critical care centers.



Recommendations

► Assess seismic performance of critical and essential public buildings

- *Finding:* The seismic vulnerability of critical and essential public buildings throughout Oregon has not been fully assessed.
- *Action Needed:* The State of Oregon shall direct local jurisdictions to determine the seismic resilience of all critical and essential public buildings.

⁷ The commercial core here is the area west of the Willamette River extending to the I-405 freeway, about 13 city blocks, and south from Union Station to Portland State University and I-405. This area also includes the RiverPlace and Pearl District neighborhoods and the Old Town/China Town Districts.

⁸ These commercial districts include the Hawthorne District, the Broadway District, the Albina District, the Lloyd District, The Goose Hollow, Multnomah Village, Interstate Avenue, MLK, St. Johns, and so on. These areas include a significant inventory of mostly service businesses, restaurants, theaters, and in the case of the Lloyd District, a major shopping mall.

FOOD SUPPLY

Given that businesses cannot survive without their workforces or their customers, and given that people cannot survive for long without food, the food supply is inexorably linked to the survival of businesses. It is unlikely that a large proportion of the population currently stores more than a few days' worth of food—and probably stores even less water—in their homes. It is almost certain that a Cascadia subduction zone earthquake will cause all private and public utilities to fail; this means there will be no municipal water or sewer service, no electricity, no telephone, and no television, radio, or internet. Without power, local grocery stores will be unable to keep frozen foods frozen or fresh meats and dairy cold enough to prevent spoiling. It is likely that most of the food in the grocery stores will be distributed (as opposed to sold) to the public because the store's registers will not work without power and there would be no sense in letting frozen foods, meats, and dairy products spoil in the store.

Because stores are routinely resupplied several times each week, the amount of food actually held in an individual store is probably no more than what is required to supply the surrounding neighborhood for a few days. In particular, fresh fruits, vegetables, and dairy products are typically replenished several times a week, so the quantities kept in stock are not large. With supplies already limited, a related concern is that people will hoard food out of fear that stores will run out completely. In the near term, such hoarding will exacerbate the erosion of the food supply.



Figure 2.8: Brooklyn, N.Y., Dec. 4, 2012 -- Local Red Hook business, Cornell Paper and Box Company, continues cleanup of boxes at the warehouse that was flooded during Hurricane Sandy. (Source: Jocelyn Augustino/FEMA)

Once the food supply at local grocery stores is exhausted, the government will have to set up food distribution centers to support the population until local grocery stores regain electrical power and municipal services and can be resupplied. That resupply activity also requires the transportation and distribution network to be functioning (see Figure 2.8). Transportation lifelines have to be open for trucks to deliver the food, and truckers have to know where the lifeline routes are located and which bridges have been seismically braced and are safe to use following the earthquake. The transportation of supplies by truck is further dependent on the fuel supply. Currently, Oregon’s liquid fuel supply is severely constrained. The main liquid fuel depot in the Portland Metro area is a “tank farm” located in

Northwest Portland, adjacent to Highway 30, built on soils that are highly susceptible to liquefaction.

Finally, the resupply of food is dependent on a functioning banking system. All commercial transactions at grocery stores involve a debit or credit card issued from a bank (or the Oregon Trail cards issued by the state), a check (which is nearly always scanned to prevent fraud), or cash. Even after electrical power is restored and communications between stores and banks re-established, the banks themselves have to be functioning in order to assure the stores that transactions will result in actual payment (see Figure 2.9). Even cash purchases will require banks to have cash to distribute, and the banks’ own information systems have to be functioning in order for them to distribute cash to their customers via bank teller or ATM network.



Figure 2.9: Hoboken, N.J., Nov. 3, 2012 -- Bank of America and other banks have set up mobile ATMs for survivors of Hurricane Sandy to get cash to spend at stores that are open for cash customers. (Source: Photo by Liz Roll/FEMA)



Recommendations

► Strengthen transportation lifelines

- *Finding:* Transportation has been identified as a major linkage in the business recovery chain. Inability to access office buildings due to failed bridges will have a devastating effect on business recovery efforts.

- *Action Needed:* The Oregon Department of Transportation (ODOT) shall identify and repair major lifeline routes in and out of major business centers statewide. Prioritize and seismically upgrade these lifelines by 2030. The state must also arrange for alternate modes of transportation in and out of the major population areas in Oregon.

PUBLIC & PRIVATE UTILITIES, INFRASTRUCTURE AND TRANSPORTATION

In Figure 2.6 above, the transportation network is shown as a separate sector from the utilities and infrastructure sector, but these sectors have strong interdependencies. Utilities cannot be repaired if roads and bridges are impassable. Likewise, the communication infrastructure is interdependent with the transportation network. If communications systems are down, repair crews have no way of knowing where they are needed most.

It is axiomatic that workers need a functioning transportation system in order to get to the workplace; one only needs to look at rush hour traffic, on a bad day, across the Interstate Bridge linking Vancouver, Washington and Portland, Oregon to observe an example of how the transportation network affects the workplace. On December 14, 2007, the City of Portland allowed contractors working on separate projects⁹ to close all but one lane of SW 4th and SW 6th Avenue on or near SW Harrison Street, near the southern end of downtown. All traffic traveling north through the downtown core from the I-405 freeway, Barbur Boulevard, and SW 1st Avenue¹⁰ were squeezed down to two traffic lanes on 4th and 6th Avenues and two northbound lanes of Naito Parkway. The result was gridlock, with cars taking more than an hour to move through downtown.¹¹ What happened that night, similar to many other December nights that year, illustrates what can be expected following a Cascadia earthquake, with many roads impassable and many bridges closed. The challenge of getting the workforce home after a Cascadia event that occurs during the workday may be dwarfed by the challenge of getting the workforce back to work.

The Willamette River bisects all of Oregon's major commercial centers: Portland, Salem, Eugene, Corvallis, and Albany. In Portland, nine bridges—the St. Johns, Fremont, Broadway, Steel, Burnside, Morrison, Hawthorne, Ross Island, and Sellwood—were all built before modern seismic codes were in force. Multnomah County bridge engineers have stated that they do not expect their bridges to collapse into the river; however none are expected to be passable prior to inspection in the event of a Cascadia earthquake. What this means is that many of the workers in the downtown core of Portland will not be able to get home if they live east of the river. The west side Highway 26 tunnels, built in the 1960s, may not be passable following a Cascadia earthquake. Highway 26 is a major transportation artery between Portland and its west side suburbs (though the tunnels can be circumvented via SW Jefferson Street).

⁹ On SW 4th Avenue it was the Cyan Apartment Project and on SW 6th it was the Portland State University Student Recreation Center.

¹⁰ SW 1st Avenue's northbound lane ends at SW Harrison and traffic heading north has to either go east to Naito Parkway or west to SW 4th, SW 2nd Avenue (and 3rd) was abandoned when the South Auditorium Urban Renewal Development was built in the 1960's.

¹¹ A snowstorm at the time contributed to traffic slowing, but this condition would mirror the problems we would face in the aftermath of a Cascadia earthquake.



Figure 2.10: Sea Bright, N.J., Jan. 25, 2013 -- Some businesses have permanently relocated to higher ground after being destroyed by Hurricane Sandy. (Source: Photo by Liz Roll/FEMA)

Before a business can reopen following a Cascadia earthquake, the building it occupies has to be certified to be structurally safe, it has to be served by municipal and private utilities, and the communications infrastructure must be operating. A business that cannot reopen within a month of a major earthquake or other disaster resulting in extended service disruption will likely never reopen at its previous location (see Figure 2.10). Potable water, sewage systems, heating (natural gas or electric), and ventilating systems must be operable before workers can reoccupy a business. To a lesser extent, but nevertheless important in our ever more technologically oriented business environment, the communications infrastructure must be re-established before businesses can be re-established. These requirements set the performance benchmarks for the transportation and utility infrastructure sectors.



Recommendations

- ▶ **Improve seismic performance of infrastructure for rapid community recovery**
 - *Finding:* Business and community cannot recover within two to four weeks due to inadequate seismic performance of infrastructure.

- *Action Needed:* Upgrade existing infrastructure and increase seismic design standards for new infrastructure over the next 50 years to enable business and community recovery within two to four weeks.

Considerations for Different Sectors

As with all state economies, there are multiple business sectors in Oregon, and a Cascadia earthquake will affect each differently. A manufacturer, for example, could sustain significant damage to machines and equipment used to make products and suffer from the lack of raw materials in the immediate aftermath of the earthquake prior to repair of roads and bridges. In addition, even if the manufacturer is able to resume production quickly, the firm may not be able to ship products to market because the transportation system may not be available.

Service providers come in all shapes and sizes, from small consulting practices to large medical clinics. These will be affected differently by a Cascadia earthquake depending on the service they provide and the customer base. Companies that provide consulting services within the locality or region may not have a customer base for some time into the recovery. Others, like doctors' offices for example, will be pressed into service during the immediate recovery period and most likely for some months. However, it is also unknown how those services will be reimbursed or how liability for "bad outcomes" will be dealt with. It is our assessment that small service businesses like sundry shops will not survive in the central business cores that suffer significant damage, particularly those businesses dependent on sales to building occupants who may not return to their place of employment for some time (see Figure 2.11).

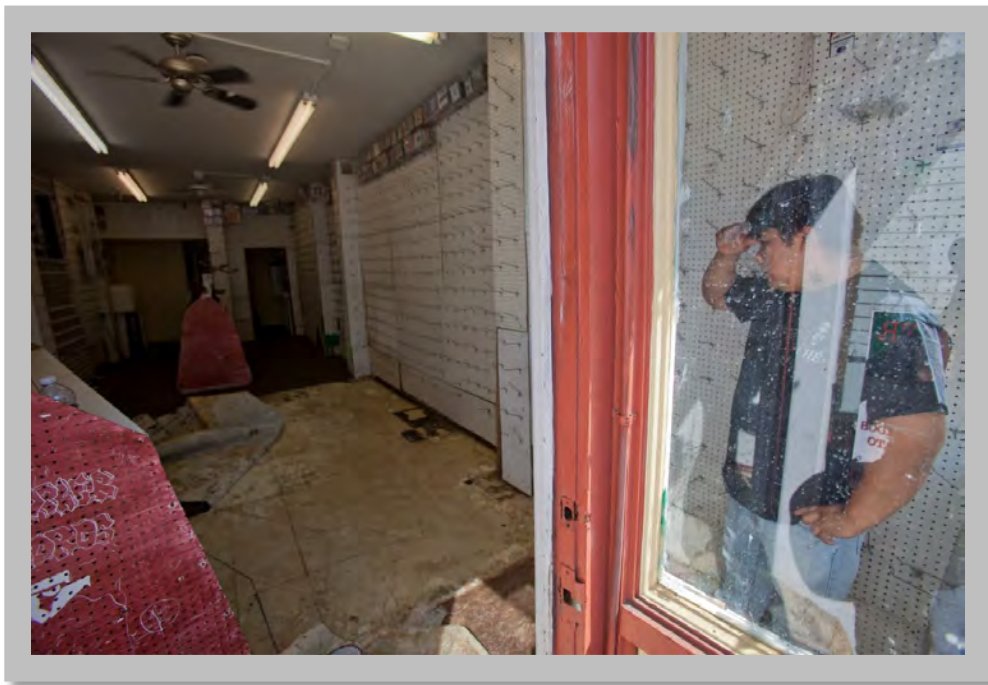

Figure 2.11: Bound Brook, N.J., August 30, 2011 -- Business owner, Brijo Garcia returns to clean up his internet store after Hurricane Irene swept through the Bound Brook area. (Source: Andrea Booher/FEMA)

Even though the goal is to have businesses up and running in two to four weeks, it seems unlikely that most customers will be making anything beyond the most essential purchases. Clothing stores, tailors, and other retail stores will suffer a prolonged period of depressed sales. These types of businesses should prepare for a Cascadia earthquake by building capital sufficient to help the business endure a prolonged disruption.

Some retail businesses, such as home repair,¹² plumbing supply, hardware, lumberyards and so on, will likely see their sales skyrocket during the immediate aftermath of a Cascadia earthquake. One problem facing homeowners who suffer earthquake-related damage to their homes will be finding construction contractors to repair the damage (assuming they cannot repair it on their own). Hurricane Andrew in 1992 drew hundreds of contractors to South Florida from as far away as Portland, Oregon. Many of the contractors in South Florida were there to repair roofs damaged in the Hurricane's high winds; an earthquake will cause different types of structural damage that will require more sophisticated contractors and likely require the services of structural engineers (see Figure 2.12). However, the potential exists for unlicensed contractors to enter the region affected by a Cascadia earthquake, and local building officials and the police will have to be aware of this potential problem.

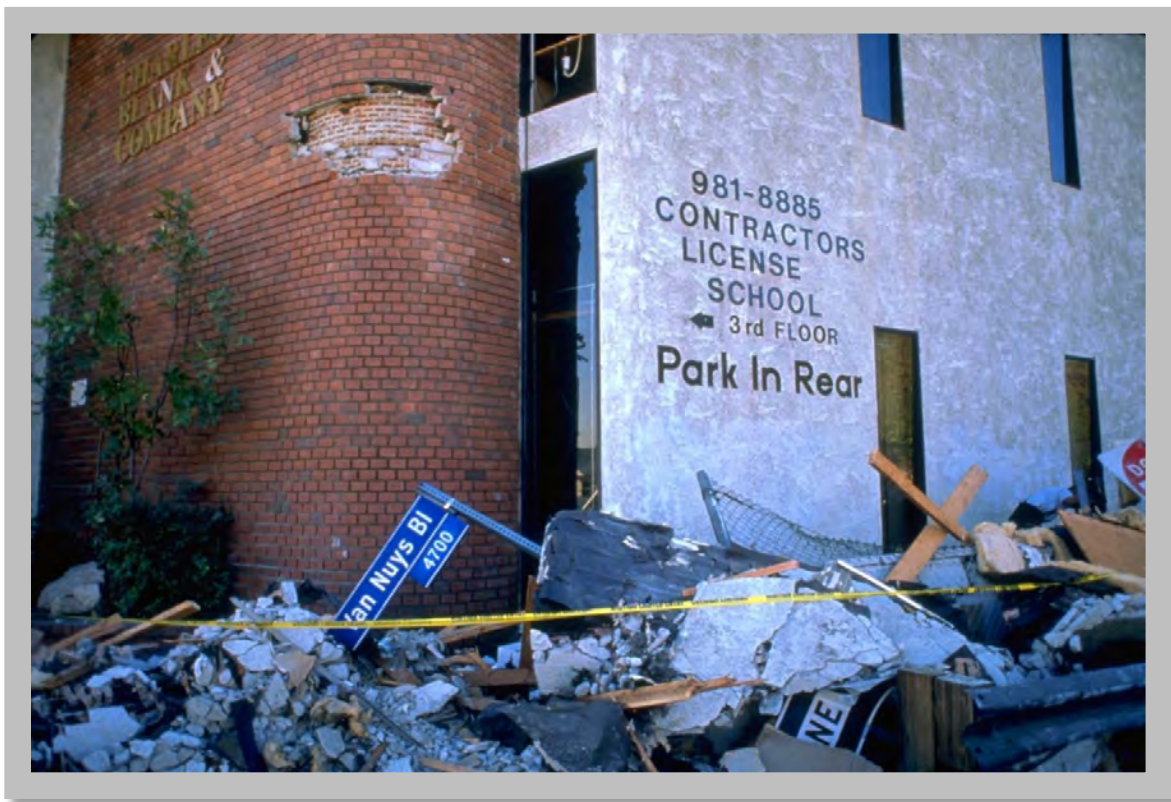

Figure 2.12: Northridge Earthquake, Calif., January 17, 1994 -- Approximately 114,000 residential and commercial structures were damaged and 72 deaths were attributed to the earthquake. Damage costs were estimated at \$25 billion. (Source: FEMA News Photo)

¹² Companies like Home Depot and Lowes, for example

Businesses that offer services outside the affected region¹³ are likely to be the least affected by a Cascadia earthquake. The demand for their services may not suffer, and their recovery will be more closely linked to the public infrastructure recovery discussed above. Once they can reoccupy their buildings or offices, they will be able to resume work.

A large portion of Oregon’s Willamette Valley remains in agricultural production. Other than damage to equipment, many of these types of businesses will suffer minimal impact to their operations from a Cascadia earthquake. The notable exceptions are agricultural businesses located at or near the Oregon Coast. Some of these businesses suffered significant losses in the 2007 flooding and windstorms; losses from a major tsunami are likely to be much greater. For further discussion of the special challenges facing coastal enterprises, see Chapter Three.



Recommendations

► Plan for business continuity

- *Finding:* Although there are numerous resources for business continuity planning, we are unaware of evidence that the majority of businesses in Oregon have a business continuity plan.
- *Action Needed:* Assess hazards that could impact business; develop business continuity/continuity of operations plan; partner with public sector to assess public/private building stock pre-event and help with post-event recovery. Business and building owners should be encouraged to review their business continuity plans and level of seismic vulnerability with respect to the Cascadia earthquake and to seismically upgrade their buildings. Employees must be trained to be their own first responders.

► Expand emergency operation efforts to support private business for rapid resumption

- *Finding:* To date, the State has not included the private sector in its Emergency Operation Centers (EOC).
- *Action Needed:* Encourage all Emergency Operation Centers to pursue public/private partnerships to enhance communication and coordination with the private sector after a major seismic event.

Cascadia Earthquake Aftermath

In the initial aftermath of a Cascadia earthquake, escaping the building safely will be the highest priority for businesses and their workers (Figure 2.13). Making workplaces safe before the event, as discussed in the previous section, will increase the chances that building occupants can exit unharmed. Several considerations need to be addressed by businesses in preparing for the immediate aftermath of a Cascadia subduction zone earthquake.

¹³ Examples of these types of firms would be attorneys with overseas clients, accounting firms, architects and engineers that have a significant amount of their business outside the region, software developers, advertising agencies, and so on.

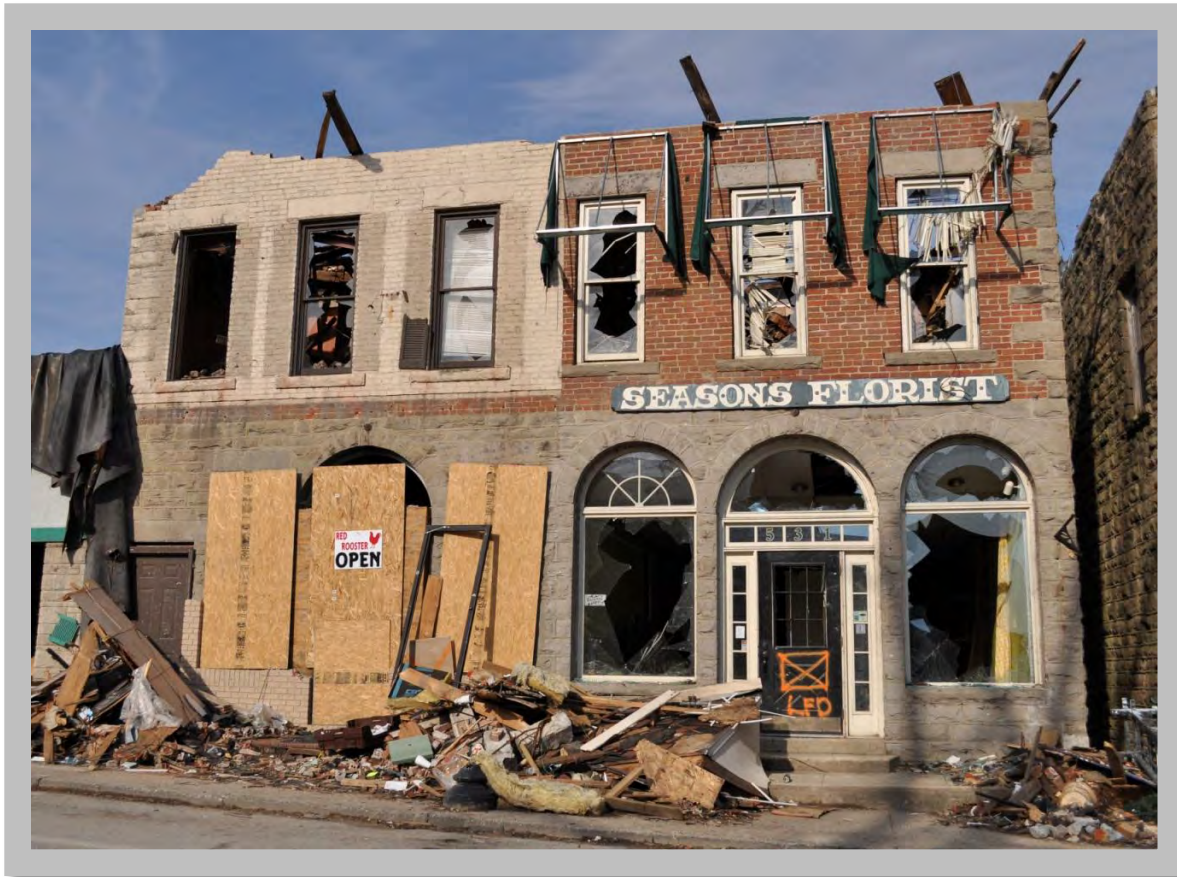

Figure 2.13: West Liberty, Ky., March 19, 2012 -- Destroyed buildings, many with historical significance, line the streets of downtown West Liberty. FEMA is working with Commonwealth and local officials to remove debris and demolish buildings that cannot be saved. (Source: Photo by Marilee Caliendo/FEMA)

If a Cascadia earthquake occurs during the workday (a one in three chance), workers will be in their offices or industrial plants during the event. In areas of the state where the Willamette River bisects the cities—Portland, Salem, Albany, Corvallis/Lebanon, and Eugene/Springfield—it is possible that a large number of workers will be trapped on the “wrong side” of the river. This will be a particular concern in Portland, where none of the ten bridges that currently carry automobile traffic is likely to be cleared by local officials to allow auto traffic for up to 72 hours, even if the bridge appears to have sustained no damage. The most recently constructed Willamette River bridge in Portland is the Fremont Bridge, built in 1976. Some renovations have been performed on the Broadway, Morrison, and Hawthorne Bridges in recent years, but the Multnomah County Bridge Division maintains that these upgrades have only brought the bridges up to level where those bridges were reinforced so that they will not collapse. The Sellwood Bridge is currently being reconstructed to modern seismic standards by Multnomah County and a new light rail bridge is currently being constructed by Tri-Met between the State-owned Marquam and Ross Island Bridges. The Marquam Bridge was opened in October 1964, and has had some seismic strengthening done since, but it is not expected to be immediately usable following a Cascadia earthquake, and may require some repairs before re-opening. The Ross Island Bridge is second only to

the existing Sellwood Bridge as the most unsafe bridge crossing the Willamette River in Portland due to unstable foundation on the east side, and is unlikely to be usable following a Cascadia earthquake.

It is likely that many of the workers in Portland’s downtown core who live on the east side of the Willamette River would be forced to shelter in their office buildings, if those structures are safe enough for that purpose. In absence of that, local downtown parks and open spaces would be natural shelter and triage sites.

Buildings that do survive and are capable of sheltering-in workers will face significant challenges related to building security and liability. Most large buildings in downtown Portland have a large number of tenants, and it is unlikely that any one person in a building knows all of the building occupants by sight. This means that there is a distinct possibility that someone who does not work a particular building may end up sheltering-in there. Building owners will have to provide first for the security of their tenants.



Figure 2.14: Mt. Olive, N.J., Nov. 12, 2012 -- After almost two weeks without power in the town of Mt. Olive, shop owners want to let people know the power has been restored and the mall is open for business. (Source: Photo by Sharon Karr)

A second concern for building owners is health and sanitary conditions (Figure 2.14). It is unlikely that water and sewer systems will work in the immediate aftermath of a Cascadia earthquake. Persons sheltering in a downtown office building will not be able to use or will have limited use of its

bathrooms.¹⁴ Sheltering –in is probably only going to be acceptable for one night, and only if an earthquake strikes in the mid to late afternoon on a short rainy or snowing winter day. If an earthquake strikes during a summer workday, when daylight extends well past 9 PM, it is likely that most workers will try to find some way to get home, even those who work on the opposite side of the river from where they live. Nevertheless, businesses in Oregon’s river-bisected cities need to plan for the possibility that people could have to shelter-in for several days, even if that possibility seems remote.



Recommendations

► Communicate gaps between current and target relief and resilience ratings

- *Finding:* The impact of a Cascadia earthquake and tsunami will be severe, especially for coastal communities. Earthquake ground shaking will damage buildings and infrastructure and disrupt lifelines. In addition, there will be near total destruction in the tsunami inundation areas that will result in large displacements of residents and visitors. Based on current expected levels of service disruption, the standard recommendation for the public to be prepared for 72 hours should be revised to at least two weeks or longer.
- *Action Needed:* With an overall goal to increase awareness, a dual ratings system is proposed to give citizens information about the status of emergency preparedness and resilience efforts in their communities.
 - Adoption of a two-level ratings system. The first level would indicate the time period that citizens should anticipate relying on emergency supplies. The second level would indicate the time anticipated necessary for 90 percent restoration of roads and services.
 - The rating system should follow the four zones proposed by the Oregon Resilience Plan: tsunami zone, coastal earthquake only, valley, and eastern zone. Standards and methodology need be developed for the system to be consistent across zones, and applicable at the community level.

Cascadia Earthquake Business Planning

BUSINESS STRATEGIES RELATED TO BUILDING STRUCTURES

One of the primary goals of pursuing disaster resilience in Oregon is to expedite building re-occupancy and restore public/private services such as transportation and power back to a 90% level within two to four weeks. Following a damaging earthquake the buildings occupied by businesses will need to be evaluated for the extent of damage and level of occupancy using the three-tiered Applied Technology Council (ATC)-20 methodology (see Figure 2.15):

¹⁴ Even flush valve toilets will function by gravity, and it is possible that some facilities can remain open for urination, but without water service, actual flushing to push fecal matter down the toilet will not happen, and toilet facilities will quickly become clogged and unsanitary.

- Green-Tagged: Structures that survived the earthquake and are immediately available for occupancy (as noted above, statewide this is about 27 percent of all commercial buildings).
- Yellow-Tagged: Structures that survived with limited access but require structural repair prior to re-occupancy (about 67 percent of all commercial buildings fall into this category). The time to re-occupy will depend on several factors including location, damage to infrastructure in the surrounding area, and the extent of damage to the building.
- Red-Tagged: Structures that have collapsed or are otherwise unsafe for occupancy due to damage (in the case of collapse, the building and its contents would be a complete loss). About 5 percent of all commercial buildings will fall into this category.

For pre-earthquake business planning with respect to business operations¹⁵:

Businesses in Green-Tagged buildings will need to have municipal and public utilities restored to the building within two to four weeks or tenant businesses may move their operations elsewhere, at least temporarily. Building owner-occupied businesses are probably less likely to relocate, but still will find it hard to survive much more than one month of inactivity due to their inability to get to their buildings. In addition, building owner-occupied businesses, particularly small businesses, probably have a large share of their net worth tied up in their buildings. This means that they are disproportionately likely to suffer losses from fire, or from burglary and looting, following a Cascadia earthquake. For businesses in Green-Tagged buildings, the business strategy following a Cascadia earthquake would be to back up intellectual capital off-site, and retrieve important documents or equipment following the event, as soon as it is safe to re-enter the building. Of course, this will be limited to the things that can be carried out by hand. If possible, a business may need to plan to set up shop temporarily in a building, such as a residence, which has not been damaged and is situated in a location the key business personnel can reach, continue minimal business operations if possible, and monitor reconstruction of transportation, infrastructure and utilities so that the business can re-occupy the building as soon as practicable.

For businesses in Yellow-Tagged buildings, restoring municipal services is less critical because it is likely to take several months to a year before these buildings will be structurally repaired to the extent required to allow reoccupation. Business strategy in these buildings will be to move to another location as soon as they can access the building and move business-related intellectual capital and equipment out. This will likely have to occur within one month for the reasons cited above, and moving will require at least some transportation lifelines to be open.

¹⁵ Here we separate “Business Operations Strategy” from other Business responsibilities such as making the business as safe as possible and caring for workers housed in the business’s building.



Figure 2.15: Northridge Earthquake, California, January 17, 1994 – Post-earthquake damage assessment teams coordinate between inspections to business buildings. (Source: Photo by Andrea Booher/FEMA News Photo)

For businesses in Red-Tagged buildings, restoring municipal services is irrelevant because the buildings and their contents will be a complete loss. Following earthquakes in California, businesses located in Red-Tagged buildings were not allowed to re-enter to retrieve equipment or intellectual capital, even if they agreed to hold the government harmless should the building collapse when they were inside. Businesses that occupy buildings unlikely to survive a seismic event in a condition that can be reoccupied need to have their intellectual capital backed up off-site and should be insured against a seismic event.



Recommendations

► Institutionalize post-earthquake assessment inspection process

- *Finding:* The State of Oregon has only a passive approach to training and registering certified structural inspectors and certified plan examiners as Applied Technology Council (ATC)-20 post-earthquake damage assessment inspectors and no formal process for deployment.
- *Action Needed:* State shall sponsor annual ATC-20 trainings at no cost to qualified engineers and certified plan examiners and indemnify all trained ATC-20 inspectors. The state must negotiate mutual aid agreements with professional associations and our neighboring states to increase ATC-20 certification and disaster response capacity.

► Develop seismic rating system for buildings to promote resilience

- *Finding:* Oregon does not have a seismic rating system for the expected performance of buildings subject to earthquake ground motions.
- *Action Needed:* State should develop a seismic rating system modeled after Structural Engineers Association of Northern California rating system. The objective of this system is (1) to make buildings more resilient and usable after a Cascadia event and (2) to help communicate seismic risk to the general public.

► Incentivize seismic upgrade of existing buildings

- *Finding:* The majority of buildings in Oregon were built before the code change of 1994 and thus do not meet current seismic building code standards. Seismic upgrading of these buildings is expensive and is typically only done when there is a change-in-use of the building, or when the buildings are substantially modified. If only a small portion of these buildings will be seismically upgraded over the next fifty years, then the potential loss of the business and workforce housing in these buildings will seriously impact the recovery of the economy following the Cascadia earthquake.
- *Action Needed:* The State should consider incentives and other options to encourage building owners to seismically upgrade their buildings.

► Reduce community vulnerability from unreinforced masonry (URM) buildings/non-ductile concrete buildings

- *Finding:* The Historic Preservation League of Oregon (HPLO) estimates there are between 5,000 and 10,000 unreinforced masonry (URM) buildings in Oregon.
- *Action Needed:* State shall adopt the findings and recommendations in the 2012 HPLO Special Report, *Resilient Masonry Buildings*, and extend the recommendations to all non-ductile concrete buildings.

BUSINESS STRATEGIES FOR COASTAL COMMUNITIES

The Oregon Coast can anticipate that a Cascadia subduction zone earthquake offshore will generate a tsunami similar to the March 2011 Tohoku earthquake in Japan. The Department of Geology and Mineral Industries has published numerous inundation maps that show whole communities including, for example, downtown areas of Cannon Beach and Seaside as being prone to complete inundation. Likewise, low-lying areas including Lincoln City, Neskowin, Rockaway, Tillamook, and Bandon will be inundated. Businesses in these tsunami inundation zones will be wiped out even more completely than businesses housed in Red-Tagged Buildings discussed above.



Figure 2.16: New Orleans, La., October 9, 2005 - This souvenir shop is open for business in New Orleans despite the sidewalk being blocked by crushed vehicles and debris leftover from Hurricanes Katrina and Rita. (Source: Robert Kaufmann/FEMA)

Businesses located in tsunami inundation zones should consider the business strategies outlined for businesses housed in Red-Tagged buildings. A high proportion of the businesses in Oregon's coastal communities cater to the tourist industry (see Figure 2.16). Most of these firms are small (or very small) businesses that would not be expected to survive following a tsunami. Even if a business had sufficient capital to relocate, it is unlikely that the tourist industry will recover rapidly enough to support business start-up. Local authorities may need to keep tourists out of the inundation zones, for safety reasons, for months or years after a tsunami.

In the event of a tsunami similar to the Tohoku event, coastal business owners' first concern will be personal survival, not business survival. Oregon's coastal communities face resilience challenges so unique that they are addressed in detail in Chapter Three.

References

1. Pelling, M., Oezerdem, A., and Barakat, S. (2002). "The Macroeconomic Impact of Disasters." *Progress in Development Studies* 2(4):283-305.
2. ECLAC (2003). *Handbook for Estimating the Socio-Economic Effects of Disasters*. United Economic Commission for Latin America and the Caribbean.
3. Cavallo, E. and Noy, I. (2010). "The Aftermath of Natural Disasters: Beyond Destruction." *CESifo Forum* 11(2): 25-35.
4. *The Economist* online (2011). "Natural Disasters: Counting the Costs." http://www.economist.com/blogs/dailychart/2011/03/natural_disasters (retrieved October 21, 2012).
5. Bureau of Economic Analysis, Regional Economic Accounts
6. Ward, B., Thoma, P., Moore, T., and Tapogna, J. (2012) "The Traded Sector in Portland's Regional Economy." ECONorthwest, Portland.
7. Noy, I. (2011). "The Economic Aftermath of the Recent Earthquake in Sendai, Japan." *The European Business Review* May-June 2011.
8. DuPont, W. IV and Noy, I. (2012). "What happened to Kobe? A Reassessment of the impact of the 1995 earthquake in Japan." *University of Hawaii Working Paper 2012-04*.
9. Lynham, J., Noy, I., and Page, J. (2012). "The 1960 Tsunami in Hawaii: Long Term Consequence of Coastal Disaster." *University of Hawaii Working Paper 2012-16*.
10. Coffman, M. and Noy, I. (2012). "Hurricane Iniki: Measuring the Long-Term Economic Impact of a Natural Disaster Using Synthetic Control." *Environment and Development Economics* 17,187-205.
11. Blanchard, O.J., Katz, L.F., Hall, R.E., & Eichengreen, B. (1992). Regional Evolutions. *Brookings papers on economic activity*, 1992(1), 1-75.
12. Sawada, Y., and Shimizutani, S. (2008). "How Do People Cope with Natural Disasters? Evidence from the Great Hanshin-Awaji (Kobe) Earthquake in 1995," *Journal of Money, Credit, and Banking* 40(2): 463-488.
13. Dorschner, J. (1992). "The Hurricane that Changed Everything," *The Miami Herald*. August 30.
14. Mill, J.S. (1872). *Principles of Political Economy*. p.47
15. Historical Preservation League of Oregon (HPLO) (2012). *Resilient Masonry Buildings*.

3. Coastal Communities

Because the coast will suffer the worst consequences of this inevitable Pacific Northwest catastrophe, we emphasize the following main actions in the next 50 years:

- Protecting lives requires consistent and relentless education and outreach based on up-to-date physical and social science.
- Investing in hazard mitigation is necessary to reduce, relocate, and avoid exposure of vital community assets to tsunami devastation.
- Strengthening of critical facilities in the earthquake-only zone must occur so that they will be available when communities need them most.
- Planning for reconstruction and recovery must be done now to provide a strategic vision for restoring the economy and livability of the Oregon coast.

Introduction

Of the Oregon Resilience Plan's eight task groups, the Coastal Task Group was the only one focused geographically on a single sub-region of the state. This group looked at the resilience of the coastal counties in the face of both the Cascadia earthquake and the resulting tsunami. To facilitate this assessment, the group divided the coastal area into the tsunami zone and the remaining earthquake-only zone. The group also recognized that almost all coastal communities have a necessary relationship with the Pacific Ocean or a connected marine environment, such as a bay or estuary. This proximity not only defines these communities, but is the basis of much of their economies, whether they are dependent on a port, recreation, or tourism. Tourism has the additional effect of bringing large numbers of second-homeowners and visitors to the coast, which means that coastal areas have a variable daily population that equals or exceeds the resident population.

The coastal region's built environment, including roads, bridges, and ports, is nestled into the coastline's natural environments of estuaries, wetlands, headlands, mountains, and beaches. It is this dependent relationship with the Pacific Ocean that creates so much of the inherent vulnerability that we now face with a Cascadia earthquake and tsunami (see Figure 3.1).

All of these communities will be affected by the earthquake. The vulnerabilities of these communities to the tsunami vary, with the northern coastal communities of Cannon Beach, Seaside, and Warrenton having the most concentrated exposure to inundation. The Coastal Task Group focused its attention on land use planning and other social factors and relied on the results and conclusions of the other task groups, which were sector based.

The tsunami creates a greater challenge for coastal communities. It is both more destructive than the earthquake and will make mitigation and reconstruction efforts more difficult. Achieving (within a 50 year timeframe) the goal of restoring 90 percent of service within two to four weeks of the earthquake and tsunami will be a greater challenge for the coast than it will be for the rest of the state.



Figure 3.1: Tsunami Vulnerability: City of Seaside with 83% of its population, 89% of its employees and almost 100% of its critical facilities in the tsunami inundation zone. (Source: Horning Geosciences)

Earthquake and Tsunami Zones

The coastal area covers the majority of the seven coastal counties of Clatsop, Tillamook, Lincoln, Lane, Douglas, Coos, and Curry, reaching up to the summit of the Coast Range. The Coastal Task Group divided the coastal area into two zones: the tsunami inundation zone and the earthquake-only zone. The relationship between these two zones will define the local and regional capacity for resilience in the context of the Cascadia event. The post-disaster welfare of the earthquake-only zone of each community is dependent on which critical and essential facilities are located inside the tsunami inundation zone. Each coastal community's capacity to respond, direct relief efforts, and begin recovery will depend on how much it relies on its tsunami-affected area (see Figure 3.2). Communities that have not successfully relocated or created redundancies for important facilities, such as emergency service facilities, energy and water facilities, and vital businesses, will have a severely diminished response and recovery capacity.

TSUNAMI ZONE

The tsunami zone is defined by inundation mapping, which was produced by the Oregon Department of Geology and Mineral Industries (DOGAMI), primarily based on the earlier mapping defining the state's tsunami inundation line and established by Senate Bill 379 in 1995. DOGAMI is currently finishing up a more accurate tsunami inundation mapping study that will be finished in 2014. Due to its proximity to the fault, the tsunami zone will be subject to among the strongest earthquake motions to be generated during a Cascadia subduction event. It will then be subject to multiple tsunami inundations generated by the earthquake, inundations which will continue for up to 24 hours after the earthquake. The tsunami will further damage buildings, bridges, roads, and utility infrastructure, and will obliterate nearly all wood frame buildings. Even steel and reinforced concrete buildings that survive the earthquake and tsunami may be damaged beyond repair. The existing utilities will be severely damaged or destroyed. The tsunami zone will also have areas of coastal subsidence—places that had been dry land above the tidal zone before the earthquake, but that, having sunk three to six feet during the earthquake, are afterwards inundated daily during high tides or seasonally by variable high tides.

The vulnerability of coastal communities to tsunami hazards varies, with the most concentrated exposure being on the northern Oregon coast (as indicated in Figure 3.3). Within the tsunami inundation zone, practically all of the 22,000 permanent residents—along with an equal or greater number of second-homeowners—who survive the tsunami will be instantly displaced (Wood, 2007). The visitor population presents a great challenge, because visitors tend to congregate in the tsunami inundation zone and have the least knowledge of where and how to evacuate. Moreover, those that survive will put extreme pressure on local relief efforts, which must provide for their initial welfare.



Figure 3.2: Critical Facilities in the Tsunami Zone – Minamisanriku, March 14, 2011. Because their hospital, emergency operation center, and other government and community service facilities were located in the tsunami inundation zone, the surviving community lost nearly all of its capacity to respond and implement recovery efforts. (Source: Asia Air Survey Co., Ltd.)

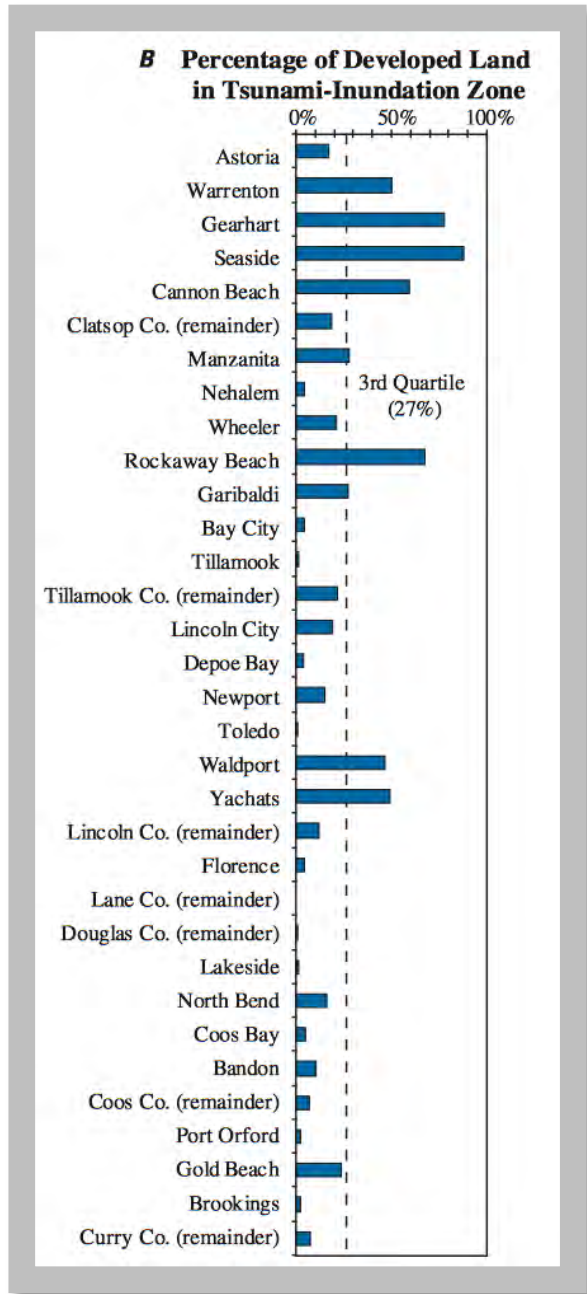

Numbers in Tsunami Inundation Zone

Residents	22,000
Households	10,000
Percent of coastal counties	4%
Employees	14,800
Businesses	1,800
Percent of coastal counties	6%
Oregon State Parks – Coastal	53,700
(Annual average daily attendance)	

Figure and numbers from Nate Wood Variations in City Exposure and Sensitivity to Tsunami Hazards in Oregon, USGS 2007

Figure 3.3: Oregon Coast Tsunami Exposure of People and Places. Wood, Nathan: 2007, Variations in City Exposure and Sensitivity to Tsunami Hazards in Oregon. (Source: US Geological Survey)

EARTHQUAKE-ONLY ZONE

The earthquake-only zone is the area outside of the tsunami zone. It includes portions of communities that will have tsunami inundations in their lowland areas, and communities that are completely outside of the inundation zone. Again, the proximity to the fault means that damage to roads and infrastructure from the magnitude 9.0 earthquake scenario will be greater here than in the valley. Minutes of strong ground shaking will concentrate damage in areas subject to ground failures such as liquefaction, lateral spreading, differential settlement, and landslides. The coast and Coast Range are particularly at risk from these effects of the earthquake.

Well-built wood frame buildings will withstand the shaking fairly well. Unreinforced masonry (URM) and under-reinforced concrete buildings will suffer significant damage. Unfortunately, this includes a number of government buildings and essential facilities in the coastal zone. Because subduction zone earthquakes generate long-period seismic waves and because the duration of the shaking is so long, certain structures, such as bridges, may resonate, amplifying shaking impacts.

Following the Cascadia Event

Following the Cascadia event, the coastal communities will be cut off from the rest of state and from each other. The coastal area's transportation system, electrical power transmission and distribution grid, and natural gas service will be fragmented and offline, with long-term setbacks to water and wastewater services. Reliable communications will be similarly affected. Because so many of these connecting systems are single lines with little or no redundancy, any break or damage requiring repair or replacement will compromise the service capacity of the entire line.

The loss of roads and bridges that run north and south will make travel up and down the coast and into the valley difficult, if not impossible, due to the lack of alternate routes in many areas. Reestablishing the roads and utility infrastructure will be a challenge, and the difficulties will be exacerbated in the tsunami inundation area by its more complete destruction. Even businesses outside of the tsunami inundation may not recover from the likely collapse of a tourist-based economy during the phased and complicated recovery and reconstruction period.

Based on the resilience targets provided by the Transportation, Energy, Communications, and Water/Wastewater task groups, current timelines for the restoration of services to 90-percent-operational levels will take a minimum of one to three years, and often over three years in the earthquake-only zone. Restoration in the tsunami zone will take even longer than that (see Figure 3.4). The most critical infrastructure is the road and highway system. Without functioning road systems, none of the infrastructure can be accessed to begin repairs.

The tsunami will also create an enormous amount of debris that needs to be gathered, sorted, and managed. The recent experience of Japan, with a similar mountainous coastline, has shown that debris management competes with shelter and reconstruction needs for the same flat land that is often in the inundation zone.



Figure 3.4: Hurricane Katrina Storm Surge – Electric Facility. Replacement of coastal power infrastructure based on 2012 capabilities may take one to three years for the Earthquake-only zone. (Source: FEMA.gov)

PREPAREDNESS AND POST DISASTER RELIEF

Emergency preparedness education and training helps people react appropriately during a disaster. Preparedness can also provide the foundation for initial disaster relief efforts at the personal, household, and community levels. Surviving the earthquake and then evacuating the tsunami zone is just the beginning of achieving life safety in the following hours, days, and even weeks (see Figure 3.5). Properly anticipating and managing relief efforts will have a significant impact on resilience.

Relief efforts need to consider other populations in addition to residents. The coast attracts a large number of second-homeowners and visitors. Data from the 2007 United States Geological Survey (USGS) study by Wood (2007) showed that the resident population in the coast's tsunami inundation area numbered around 22,000. Not included in this count was the population of second-homeowners and visitors, which in many coastal communities equals or exceeds the number of full-time residents. To arrive at a general estimate of the number of visitors to the coast, Wood looked at the number of visitors to Oregon's coastal state parks and found that the annual average daily attendance is 53,700 people. This is more than double the number of permanent residents at risk, and it does not include hotel visitors. The visiting population is generally located in the tsunami inundation zone and typically has low levels of knowledge about tsunami hazards and evacuation routes. The large population of visitors will also be difficult to house and feed adequately following the earthquake and tsunami. An essential task during the relief period will be transporting these people from the coastal areas to their own homes or to shelters further inland. Reducing the loss of life among residents and visitors is critical to insuring that people will come back to help with reconstruction and recovery.



Recommendations

► Improve earthquake/tsunami education efforts.

- Teach an earthquake/tsunami curriculum to Oregon’s school children.
- Provide information about Cascadia earthquakes and tsunami in all hotels, motels, and short-term rentals. This should include information about tsunami evacuation routes.
- Require that all businesses over a certain size and located in tsunami inundation zones have tsunami evacuation plans.

► Improve tsunami evacuation efforts.

- Create tsunami evacuation modeling for each coastal community as a base level to estimate the likely fatality level. Models can be used to test improvements in evacuation measures and determine whether the improvements will reduce fatality levels.
- Improve tsunami evacuation measures by further developing existing evacuation routes, creating new evacuation routes, bettering education and signage about evacuation routes, and creating vertical evacuation structures or buildings.

► Improve relief efforts to account for residents in the tsunami inundation areas and the visitor population.

- Develop plans to provide shelter, water, and food for residents and visitors.
- Develop plans for getting visitors back to their own homes.

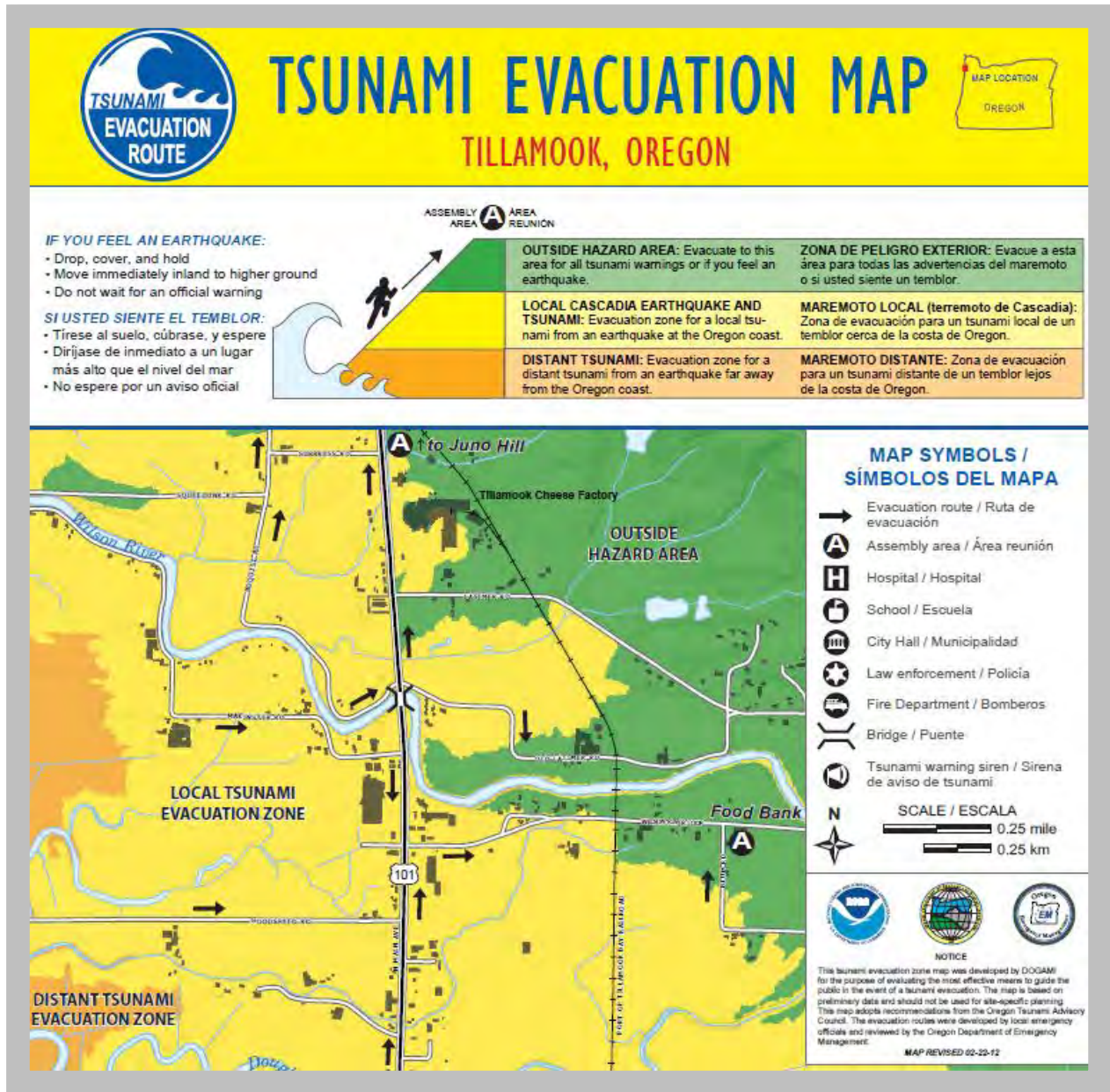

Figure 3.5: Tsunami Evacuation Map for the City of Tillamook, Oregon. (Source: Oregon Department of Geology and Mineral Industries, 2012)

Coastal Zone Targets

The goal for the coastal zone—like that of the other zones of the state—is 90-percent recovery in a two-to four-week period. This goal is based on the amount of stress businesses can take before they go out of business or relocate. While this goal should be the target for all of Oregon, it will be difficult to achieve in both the tsunami zone and the earthquake-only zone of the coast, with the tsunami zone presenting particularly significant obstacles. Consequently, it will likely either take longer to achieve this goal on the coast than it will in the other regions of the state, or it will require the application of substantial resources. Some coastal communities will have to reconstruct their economic districts—either substantially or completely. Alternate strategies need to be considered, and the expectations of coastal residents and businesses must be addressed with the realities of the state of preparedness.

PROTECTING BUILDINGS AND INFRASTRUCTURE

The first obstacle is the anticipated level of destruction of buildings and infrastructure within the tsunami zone. The solutions to protecting them include:

- Creating tsunami resistant seawalls. This solution has been tried in Japan, and it works provided that the wall is designed for the earthquake/tsunami that actually occurs. The failure of these structures in the 2011 Tohoku earthquake and tsunami was primarily due to their having been designed for a smaller event. They are very costly and would cut off the communities from the ocean, disrupting the main economic basis of many coastal communities. Moreover, this solution does not address such things as port facilities, which need direct access to the ocean.
- Constructing tsunami resistant buildings and infrastructure. This type of solution is typically used for port facilities, roads and bridges, and other essential buildings or infrastructure. It is very expensive and would be done in critical cases where other options do not exist. This solution does not address existing buildings and infrastructure.
- Relocating. While it is theoretically possible to relocate communities, in reality this rarely happens, even following major earthquakes and tsunamis. A more likely scenario is relocating essential buildings and functions outside of the tsunami zone as a mitigation strategy. In this way, police stations, fire stations, government offices, hospitals, public works, and similar critical facilities can, over time, be shifted outside of the tsunami zone. In addition, some thought can be given to the relocation of businesses and residences.

As Wood's study shows, the vulnerabilities of communities within the tsunami zone vary, so the solutions must vary accordingly (Wood 2007). Mitigation proposals should be developed that include actual mitigation projects—such as relocation—as well as more land-use related solutions that look at rebuilding communities after the earthquake and tsunami so that they are tsunami-ready for future events.

The target goal in earthquake-only areas of the coast also presents challenges. First, much of the essential infrastructure runs through both the tsunami zone and the non-tsunami earthquake zone.

Second, the geology of the coast means that there will be high levels of damage to these systems. Because these areas are lightly populated compared to the urban areas of the valley, strengthening them will tend to be a lower priority (from an economic standpoint) than projects that target the valley.



Recommendations

- ▶ **Use relocation strategies to meet target goals on a community basis as part of overall mitigation planning.**
- ▶ **Use tsunami resistant buildings as vertical evacuation structures to insure the safety of people in the inundation zone where other options are limited.**
- ▶ **Use tsunami resistant infrastructure for critical transportation, port facilities, and utilities.**
- ▶ **Ensure that critical transportation links to the valley and along the coast survive the earthquake so that coastal communities are not cut off from relief and recovery efforts.**

Government/Essential Facility Continuity

Given the high level of destruction in the tsunami zone, it is important that government buildings, essential facilities, and schools continue in operation following the earthquake and tsunami. Experience from the Tohoku earthquake/tsunami in Japan and other natural disasters in the U.S. and other countries has shown that where government continuity has been disrupted, post-disaster recovery times have been greatly increased. In addition to continuity of governments within the coastal zones, the capacity to communicate with state government offices must be firmly established.



Recommendations

- ▶ **Upgrade, or replace with buildings that meet or exceed current seismic codes, all government buildings, schools, and essential facilities located in the earthquake-only zone.**
- ▶ **Make all government buildings, schools, and essential facilities located within tsunami zones more resilient by adopting one of the following strategies:**
 - Relocate the facility outside of the tsunami zone.
 - Build the facility with reinforced concrete to resist tsunami loads. (If such a strategy is adopted, consider using the facility as a tsunami vertical evacuation refuge (TVER).

- Upgrade the facility to meet seismic life-safety standards, and create a backup facility outside of the tsunami zone.

Land Use

This resilience planning effort encourages a comprehensive, risk-based approach to reducing exposure and vulnerability to all natural hazards that potentially affect our coastal communities. Options and recommendations within this section should be helpful in assisting communities move forward in these important efforts. However, if a community needs to relocate a specific facility (for example, a hospital, fire station, police station, emergency response center, or school) in the short term to reduce tsunami risk, then utilizing a more strategic approach may be necessary and appropriate.

The need for pre-disaster relocation of government buildings, schools, and essential facilities has the potential to raise land-use issues. In some communities, such as Cannon Beach and Seaside, existing business areas may become part of new tidal zones after a Cascadia subduction earthquake as a result of subsidence. In some situations, such as the Seaside School District's relocation effort, sufficient existing land is not available inside the urban growth boundary for relocation, so it is necessary to collaborate with stakeholders to look at other appropriate sites. In other cases, such as the Waldport High School project, relocation can be accommodated within the existing urban growth boundary. In the Waldport case, it was necessary to maintain the vacated site as open space due to the requirements of FEMA funding, which assisted substantially in the relocation effort. FEMA funding can be very helpful in the development and implementation of community relocation strategies; however, there are situations in which these funds are not available or maintaining vacated sites as open space is not workable for a community. In these cases, transitioning to a more resilient community may dictate that the vacated site not be removed from the community's tax base, but instead be considered for (and used to help fund) the development of low-risk uses or uses which include appropriate and adequate protection or mitigation for seismic and tsunami risks.

The economies of most coastal communities are based on their proximity to the ocean. Ports, by their very nature, will always be in tsunami zones. Similarly, towns such as Cannon Beach and Seaside exist due to their close proximity to the ocean. Rethinking how ports can return and tourism can rebound following a Cascadia event will require an inspired strategy on the part of coastal communities and the state. (It should be noted that Oregon's coastal ports were built to support fishing and logging, and in many places, these industries are no longer the economic motors they were when the port facilities were built.) In addition, future development within the tsunami zone should seek to reduce risk. One hopeful sign is that 50 percent of growth since 2000 and 2010 census in coastal communities has been outside the tsunami zone (Personal communication with Wood, 2012).

SENATE BILL 379 TSUNAMI INUNDATION ZONE

In the mid 1990's, Senate Bill 379 directed the Department of Geology and Mineral Industries (DOGAMI) and its board to adopt a tsunami inundation line, and established requirements and restrictions for

certain development within the identified inundation zone. These requirements are found within ORS 455.446-447 and are administered within the Oregon Building Code. DOGAMI is currently remapping the Oregon coast for tsunami hazards. This new analysis is more comprehensive and uses updated methodology developed as a result of analysis of recent tsunami events and further Cascadia earthquake and tsunami research. The DOGAMI Board will soon review this new work to determine how this information should be used for purposes of administering the development restrictions of ORS 455.446-447. This updated mapping, and associated requirements as indicated, will be important considerations for local governments' comprehensive planning efforts and the development of implementation measures as required by Oregon Statewide Planning Goal 7, 17 and 18 (see <http://www.oregon.gov/lcd/pages/goals.aspx> for details).

OREGON DEPARTMENT OF LAND CONSERVATION AND DEVELOPMENT (DLCD) AND ITS COASTAL MANAGEMENT PROGRAM (OCMP)

Statewide Planning Goal 7 requires local governments to adopt comprehensive plans (inventories, policies, and implementing measures) to reduce risk to people and property from natural hazards and to address concerns about life safety, lifelines, economic viability, and infrastructure. Natural hazards include earthquakes and related hazards, tsunamis, and coastal erosion. DLCD is the agency charged with the responsibility of assisting local governments and local communities in addressing and planning for these hazards.

DLCD is charged with working with DOGAMI and local governments to address the implications of the updated tsunami inundation zone mapping for community development and comprehensive planning. This includes assisting local governments to develop adequate adaptation planning responses in anticipation of a major tsunami event. As part of this effort, DLCD has clarified specific policies that identify the tools that communities can use when adjustments to urban growth boundaries are required, or comprehensive long-term resilience planning is needed. These include:

- Urban growth boundary adjustments to address tsunami risk. Urban growth boundary expansions may be needed to allow for relocation of some community facilities due to tsunami hazard risks—if land is not suitable within the boundary. These would be strategic measures for a single purpose and would be subject to existing urban growth boundary requirements.
- Urban reserves. Communities may use a more comprehensive risk-based approach to reducing exposure and vulnerability to all natural hazards that may affect a community. This approach would be a longer-term effort and would help in situations where land-use zones would no longer be tenable or desirable following the event. Urban reserve work could include planning areas outside the urban growth boundary in preparation for pre- and post-disaster land-use efforts. This comprehensive approach could also help define what associated rezoning efforts would be needed inside the urban growth boundary.
- Community land use tsunami preparation. DLCD has placed a priority on supporting community land use tsunami preparation and on providing tools to help communities become more

resilient to this catastrophic hazard. In order to provide this assistance, the DLCD will partner with a qualified consultant to develop an array of best practices and tools which are tailored to the comprehensive plans of coastal local governments and statewide planning goals. This work will require comprehensive research, creative thinking, and compilation of an extensive set of resilience options, including a range of both land use incentive and regulation tools. This effort anticipates the development of a set of comprehensive tsunami resilience tools, which include such things as a tsunami hazard overlay zone and other land use related tsunami resilience provisions.



Recommendations

- ▶ **Encourage coastal communities to adopt the latest version of tsunami maps and analysis and to include these within local comprehensive plans.**
- ▶ **Work with local communities to develop comprehensive plans and policies related to becoming more resilient to tsunamis; such plans and policies should direct and authorize associated implementation actions.**
- ▶ **Encourage communities to develop a tsunami hazard overlay zone and other tsunami resilience provisions related to land use, which could be adopted and used within local land use codes.**
 - The code language could include options for incentives, requirements, and best practices for assisting communities to become more resilient to tsunamis.
 - Guidance materials could include options such as incentives and regulations related to allowed uses in inundation zone areas, tsunami evacuation route requirements, use requirements for vacated areas, and mitigation measures for development within inundation areas.
- ▶ **Support local government consideration of ORS 455.446-447 requirements (as potentially amended) for minimum requirements within local comprehensive plans and implementing ordinances.**
- ▶ **Support local government efforts to apply best practices and the tools developed by the Oregon Department of Land Conservation and Development (DLCD), when revising coastal communities' comprehensive plans to increase resilience to Cascadia type events.**
- ▶ **Support local governments as they review their respective urban growth boundaries to identify key community facilities which may need to be relocated to address substantial tsunami risk. Work with communities to develop local land use policies and strategies to address future relocation of these facilities.**
- ▶ **Encourage communities to consider strategies to increase the tsunami resilience of those parts of the community that cannot be relocated.**

- These strategies could include such things as the development of structures of such size and bulk that, if appropriate for the area, a vertical evacuation structure could be included as the top component.
- These strategies may need to include revision of zoning codes to allow suitable building height provisions for these structures.

Reconstruction

LARGE-SCALE DEBRIS REMOVAL

Requirements and plans for the removal of debris must be developed on a county and community level per discussion with U.S. Army Corps of Engineers before the Cascadia event. Given the terrain of the Oregon coast, available land for such purposes will be at a premium, and the need to dispose of debris may conflict with other vital needs during relief and recovery efforts. Moreover, both the debris and its removal will have long-lasting environmental impacts. Planning for recycling and reuse of this debris must be put into place before the event to reduce landfill and environmental impacts.

The U.S. Army Corps of Engineers has indicated that local governments should identify land for response and recovery efforts as part of their planning work *before* a Cascadia subduction zone event. This essential planning will expedite debris removal activities after the earthquake and tsunami. In addition, a viable transportation system must be put in place in order for the Corps of Engineers to get the necessary heavy equipment into place. Local jurisdictions can facilitate this effort by making arrangements in advance with existing local heavy equipment operators. These plans need to include both staging areas for the heavy equipment and areas for collection and sorting of the debris.

It should be noted that there are no landfill areas on the coast, and the local transfer station areas will be quickly overloaded following the event.



Recommendations

- ▶ **Develop and implement debris management programs for the recovery period following a Cascadia subduction zone earthquake and tsunami.**
- ▶ **Look at alternative strategies to reduce environmental impacts of debris for coastal communities.**
- ▶ **Develop a tool box of creative methods to recycle and reuse debris.**

COASTAL ECONOMIC RESILIENCE

Tourism

The impact of the earthquake and tsunami on coastal businesses will be severe and long-lasting. The impact on tourism will be felt with the loss of substantial numbers of buildings and businesses. Even those that remain will not have basic services, and the road system will be down, so that even if these services could be provided locally, there would be no way for visitors to travel into the area. The state park system will be damaged, and there will be changes in the beaches and estuaries as the tides re-equilibrate to the subsidence along the coast. Recreational opportunities will become limited. In addition, the positive image that people have of the Oregon coast will be damaged if there are widespread fatalities.

Plans should be developed for reestablishing tourism following the disaster (Figure 3.6). These arrangements should include coordinated recovery plans to provide an adequate workforce so that the number of visitors will not put a strain on the surviving infrastructure. Following the disaster, visitors must be protected and provided for in such a way that they understand that the coastal communities did all they could to assist them and that this understanding leads visitors to feel an attachment to the coastal communities and a desire to help them rebuild.

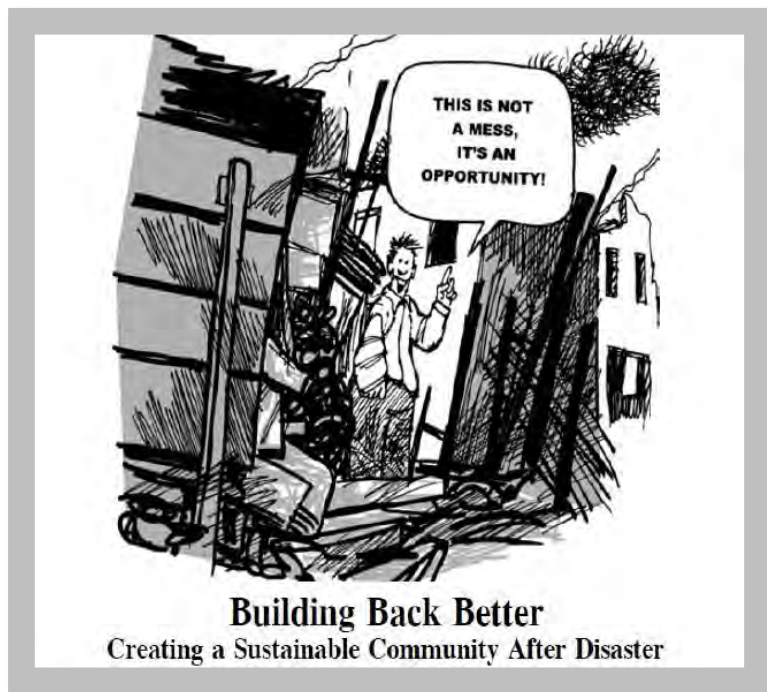

Figure 3.6: Building Back Better
(Source: www.colorado.edu/hazards)

Other Industries

- The logging industry will sustain major damage to its logging road system and will have difficulty transporting its products to market.
- The ports will sustain major damage so that goods and services will not be able to enter or leave until the ports are repaired.
- The fishing fleets may be severely damaged if they are in port when the tsunami arrives.

The Local Population

Even businesses that are not involved in tourism will be impacted by the loss of residents from the tsunami zones; and residents in earthquake-only zones will be forced to leave the area due to loss of jobs and loss of access to schools and medical facilities (see Figure 3.7). Many of the retirees who bring substantial money into the coastal communities may opt to relocate out of the area, putting further strain on coastal communities. The loss of the workforce will make it difficult for the businesses that remain to find sufficient help. For governments seeking to replace damaged infrastructure, the resulting reduction in the tax base will make recovery efforts more difficult. This problem will also hamper the efforts of the utilities providers, as demand for services will substantially decrease.



Recommendations

- ▶ **Require the state to do an assessment to determine an accurate level of coastal business operation following the Cascadia subduction zone event as a base case for recovery efforts.**
- ▶ **Require the Oregon Tourism Commission to work with the coastal hospitality industry and communities to develop plans for taking care of visitors following the Cascadia event and plan strategies for rebuilding the tourism industry after the event.**
- ▶ **Modify the use of room taxes to develop funding for mitigation efforts directly related to the evacuation of visitors to high ground, the provision of relief for visitors, and the development of mitigation and post-disaster recovery efforts. This could also include the creation of emergency funds.**
- ▶ **Develop economic incentives for recycling/reuse of post-disaster debris.**
- ▶ **Develop re-insurance or group insurance for the coastal zone to provide lower cost insurance to help with recovery efforts.**

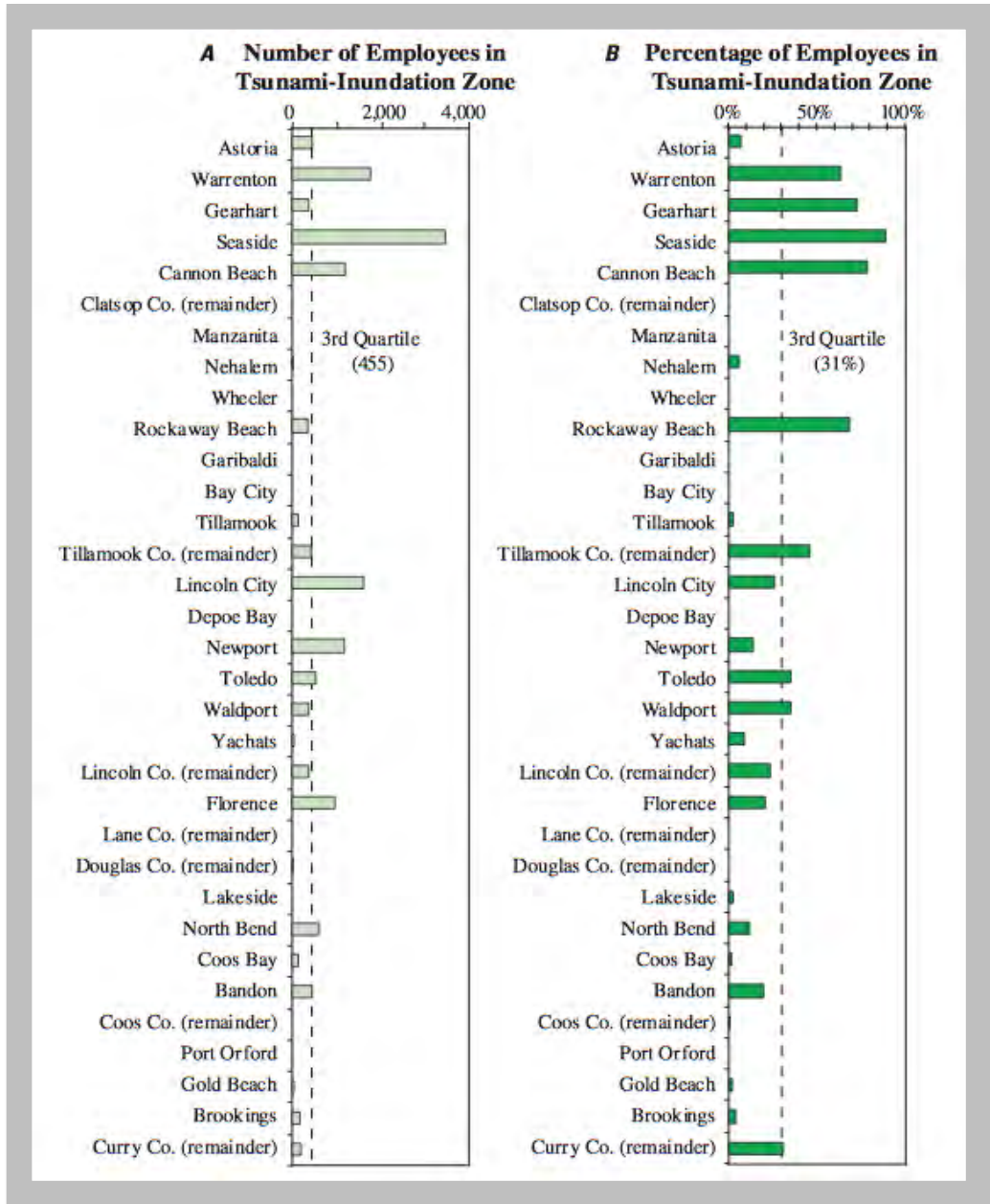

Figure 3.7: Number and Percentage of Employees in the Tsunami Inundation Zone. Wood, Nathan: 2007, Variations in City Exposure and Sensitivity to Tsunami Hazards in Oregon. (Source: US Geological Survey)

Disaster Resilience and Sustainability

Mitigation will be a primary tool in the creation of disaster resilience within Oregon’s coastal areas. Solutions that are currently thought of as *sustainable development* should be studied as part of these mitigation and post-disaster recovery plans (see Figure 3.8). One of the main reasons that Japan and Chile got back up and running from their most recent earthquakes (i.e., the 2010 M8.8 Maule Earthquake and the 2011 M9.0 Tohoku Earthquake) was that they have redundant service systems. Sustainable solutions can help provide this redundancy. Given the expected problems of energy delivery following a Cascadia event, coastal communities should explore alternatives to the statewide utility grid and, to the extent possible, work towards greater self-sufficiency. Current localized energy generation options include:

- Wave, wind, and solar as models for economic growth, improved emergency self-reliance, and less dependency on a tourism-based economy.
- The proposed energy generation plant, if it is accepted, for a Coos Bay LNG facility. This plant could have value after a Cascadia subduction zone event if it is located outside of the tsunami zone.
- Investment early in infrastructure redundancy and alternative local sources of energy for areas that will someday need to be rebuilt and relocated due to catastrophic earthquake and tsunami damage. Such investment can have dual benefits: minimizing disaster-related downtime and encouraging sustainable community development. (*Example: The Smart Grid concept <http://www.smartgrid.gov/> to invest in alternative local/regional electricity generation and distribution.*)



Figure 3.8: Disaster Resilience is a Critical Component of Community Sustainability. (Source: Public Entity Risk Institute)

HAZARD MITIGATION: PRE-DISASTER RISK REDUCTION

Natural hazard mitigation plans are required at the state, county, and city levels in order for these jurisdictions to be eligible for post-disaster FEMA grants. These plans acknowledge local and regional natural hazards and assess the related vulnerability of the community to determine the community's acceptable level of risk.

A tiered approach to mitigation should be developed:

- Top tier mitigation efforts should prioritize strengthening life-safety capacity during a worst-case-scenario event. Examples include finishing all mapping, hardening evacuation routes, increasing capacity to aid visitors, improving consistent signage, designating earthquake-resistant shelters, and stocking community emergency provisions sufficient to last for one month. This would also include strengthening existing critical facilities that are already outside of the tsunami zone.
- Tier two mitigation efforts should be to relocate critical infrastructure outside of the tsunami zone so that it is operational or repairable immediately following a Cascadia subduction zone event and is therefore able to provide emergency services (rather than being destroyed, abandoned, and useless).

Coastal hazard mitigation plans should have action items that are specific to a Cascadia subduction zone event. Such action items should call for prioritized mitigation projects to improve life safety and avoid damage or reduce exposure from the tsunami and earthquake.

PLANNING FOR RECONSTRUCTION AND RECOVERY

For legacy facilities that are too problematic to relocate, such as electric substations or wastewater treatment plants, pre-disaster recovery planning will allow community decision makers to outline goals, objectives, and strategies for realizing the more resilient and sustainable public and private sector arrangements that are to be implemented during post-disaster long-term recovery. There has been some concern expressed by utility providers about how these improvements will impact ratepayers.

Economic resilience must really address the number of local businesses that are located in the tsunami zone and the extent to which these businesses depend on services that are in (or move through) the tsunami zone. The tourism-based businesses that survive may have reduced demand following the Cascadia subduction zone event, but lodging, food, and commercial businesses can provide invaluable benefits to their communities by maintaining the capacity to operate.

Example: Timebank Concept from Lyttelton, New Zealand. *This isolated coastal community is using a concept they started called Timebank as a way to barter professional, skilled, and volunteer services to do earthquake recovery for community projects. This is a great model (at the small-community scale) for sharing the community's internal resources and a very practical model for Oregon's highly self-reliant coastal communities, especially those with a strong sense of place. (<http://www.lyttelton.net.nz/earthquake/lyttelton-timebank>)*

Recovery planning now is really about rebuilding for the *subsequent* Cascadia subduction zone event. While it may not provide any risk-reduction benefits now, it will substantially minimize uncertainty, deliberation, conflict, and delay by getting a very complicated and bureaucratic process moving forward in accordance with whatever vision the community adopts. The great importance of this recovery visioning process was revealed during a tsunami recovery workshop at Cannon Beach in 2006 (see <http://csc.uoregon.edu/opdr/recovery/cannonbeachpilot>). Coos, Curry, Douglas and Lane counties have already participated in a recovery planning process for southwestern Oregon. This process was facilitated by the Oregon Partnership for Disaster Resilience and funded by FEMA.

Having witnessed other subduction zone events during the past eight years (2004 Indian Ocean, 2009 American Samoa, 2010 Chile, and 2011 Japan)—events that are similar to what is expected from a Cascadia subduction zone earthquake and tsunami—Oregon’s coastal communities are taking stronger steps towards planning for this inevitability. With the imperative of the Oregon Resilience Plan, it is critical that limited federal, state, and local capital be wisely invested in a manner that looks forward to sustainable objectives, with an emphasis on local resources, rather than doubling down on older systems that have heavy dependencies on services delivered from out of the area.

Relief and Resilience Ratings

The initial analysis of the current state of preparedness that was done to establish baselines for resilience targets has confirmed that our levels of preparedness are low (see Figure 3.9). This analysis has also revealed the timeframes within which people in Oregon can expect relief efforts to reach them following a Cascadia subduction zone earthquake and tsunami. Relief efforts of any size will clearly need to come from outside of the area, but the transportation systems—whether travel is by highway, air, or sea—are expected to be severely impacted. The difficulties associated with delivering aid are most acute for the coastal zone, but they could also be an issue for rural areas in the valley.

Information about the likely timeframes involved in delivering aid should be disseminated to citizens and communities to allow them to plan accordingly. The standard recommendation is for people to prepare to be self-sufficient for 72 hours following a natural disaster of this kind. This standard should be raised (see Figures 3.10 and 3.11). In the tsunami zone, preparation involves evacuating to high ground. Because homes and businesses will be lost, the preparation of residents also needs to include survival kits containing some sort of shelter (protection from the elements), food and water, and any other items that the individual will need while living in temporary shelters, whether located on the coast or in other areas). Visitors in the tsunami zone will not have made these preparations and will be relying on the help of residents and communities. People in the earthquake-only zone are expected to fare better, because they will likely still have their homes—although a certain percentage of those homes will be so damaged by the earthquake that they can no longer be occupied.

Coastal communities are beginning to make preparations. For example, several communities are creating stockpiles of emergency supplies outside of the tsunami zone. Communities and citizens need

some level of transparency in order to keep track of their own level of preparation for emergency response and progress towards achieving resilience.



Recommendations

- ▶ **Adopt a two-tiered rating system that gives (1) the number of hours/days that a citizen in a community can expect to wait before major relief arrives and (2) the number of days/months that a citizen can expect to wait before the community itself achieves 90-percent restoration of roads and services.**
 - The rating system should adopt the zones established by the resilience report: tsunami zone, coastal earthquake-only zone, valley zone, and eastern zone.
 - Standards and methodology must be developed to ensure that the rating system is consistent.
 - Communities and counties should use these standards and methodology to develop standards for cities and unincorporated areas.

The goal of this two-tiered rating system is to provide information at any given time about what citizens should expect, and to serve both as the basis for a community’s resilience targets and as a means of measuring how close the community is to meeting them. Because the resilience report sets a 50-year target for achieving statewide resilience, a mechanism is needed to track progress and provide pressure to meet the target.

	RELIEF	RESILIENCE
Eastern	72 hours	1 to 3 years
Valley	72 hours	1 to 3 years
Coast (Earthquake Only)	1-2 Weeks	3 years +
Tsunami Zone	1-2 Weeks	3 years +

Figure 3.9: Existing Relief/Resilience Ratings

	RELIEF	RESILIENCE
Eastern	72 hours	2 weeks
Valley	72 hours	2 to 4 weeks
Coast (Earthquake Only)	72 hours	2 to 4 weeks
Tsunami Zone	72 hours	2-4 weeks

Figure 3.10: 50-Year Target Relief/Resilience Ratings

Coastal Service Restoration

50-Year Estimates for Roads/Bridges and Critical Facilities

ODOT Roads & Bridges		Event Occurs	0 – 24 hours	1 – 3 days	3 – 7 days	1 week – 1 month	1 – 3 months	3 – 6 months	6 – 12 months	1 – 3 years	3+ years
Coast - EQ Only Zone											
State Hwy System	Tier 1									60%	90%
	Tier 2										60%
	Tier 3										60%
	Other										
Coast - Tsunami Zone											
State Hwy System	Tier 1										60%
	Tier 2										60%
	Tier 3										60%
	Other										60%

50 Year Targets

Minimal: (A minimum level of service is restored, primarily for the use of emergency responders, repair crews, and vehicles transporting food and other critical supplies.)

Functional: (Although service is not yet restored to full capacity, it is sufficient to get the economy moving again— e.g. some truck/freight traffic can be accommodated. There may be fewer lanes in use, some weight restrictions, and lower speed limits.)

Operational: (Restoration is up to 90% of capacity: A full level of service has been restored and is sufficient to allow people to commute to school and to work.)

60% - ESTIMATED TIME FOR RECOVERY TO 60% OPERATIONAL

90% - ESTIMATED TIME FOR RECOVERY TO 90% OPERATIONAL

Figure 3.11: 50-Year Estimates for Roads/Bridges and Critical Facilities

Current 2012 Conditions for Critical Facilities in the Earthquake-Only Zone

Critical Facilities	Event Occurs	Phase 1 (hours)			Phase 2 (Days)		Phase 3 (Months)		
		4	24	72	30	60	4	18	36+
Coast - EQ Only Zone									
Emergency Operation Centers								X	
Police Stations									X
Fire Stations									X
Healthcare Facilities								X	X*
Primary Schools K-8								X	
Secondary/High Schools								X	
Emergency Shelters								X	
	Target in 50 Years								
X	Current Capability								

Figure 3.12: Current Conditions for Critical Facilities in the Earthquake-Only Zone

Disaster Resilience in Action:

- Waldport High School is the first FEMA tsunami acquisition project in the country. Lincoln County School District secured a bond to rebuild a new high school on the hill above the city.
- As of December 19, 2012, the Seaside School Board approved a resolution to authorize the superintendent to hire an architect to begin designing a new school campus, which would be constructed above the tsunami inundation zone. A long-anticipated bond measure to support this effort is expected to be on the ballot in May 2013.
- As of December 12, 2012, the Cannon Beach City Council agreed to acquire 55 acres to expand the city limits for a new school site above the tsunami inundation zone.

References

1. Wood, N. (2007). *Variations in City Exposure and Sensitivity to Tsunami Hazards in Oregon*. US Geological Survey Scientific Investigations Report 2007-5283.
2. Wood, N. (2012). Personal Communications

4. Critical and Essential Buildings

Introduction

Building safety and functionality will be critical both during and after a magnitude 9.0 Cascadia subduction zone seismic event. Oregon's buildings must be able to withstand the intense ground shaking without devastating loss of life, damage to infrastructure, or significant disruption to our communities and economy. Because of this, the Critical Buildings Task Group was assigned the task of reviewing the status of buildings in critical sectors and considering how they may be affected by a Cascadia subduction zone event. Buildings in these critical sectors include those that are necessary for the immediate response to the event—such as emergency operations centers, hospitals, police and fire stations, and emergency shelters—and buildings that are necessary for the provision of basic services to communities as they begin to restore functions and return to normal life—for example, schools, housing, certain retail stores, and banks. The group reviewed one additional building category: vulnerable buildings. These are unreinforced masonry and non-ductile concrete structures that have shown time and again in past earthquakes that they pose a very significant and direct threat to life safety.

While the task group acknowledges that there are many other buildings and sectors that could also be considered vital to resilience, the group decided to limit the study to those buildings that we believe are most critical to resilience in the case of an earthquake scenario. Buildings and structures that are directly associated with and critical to the functionality of communications, utilities, ports, water supply, wastewater, and fuel storage have been evaluated separately by other task groups; the assessments and recommendations of these task groups are provided elsewhere in this report.

To assess the overall seismic resilience of critical and essential buildings in the state of Oregon, the work group considered the gap between the building-performance goal needed for seismic resilience (target state) and the expected seismic performance of the buildings as they are today (current state). Most of the building sectors that are critical to the response to a seismic event are recognized by the current building code. Oregon's current seismic design standard for new buildings, the Oregon Structural Specialty Code (OSSC), classifies buildings according to four distinct occupancy categories based on their relative importance to life safety in the event of a natural disaster (see Figure 4.1). Occupancy Categories III and IV are structures that have large assembly areas (such as schools), or that are deemed essential to emergency response (such as hospitals, police and fire stations, and emergency operations centers). Buildings that fall under these Category III or IV classifications were obvious components of the Critical Buildings data set used in our evaluation. Under current code, occupancy category type III buildings are designed for a 25-percent higher seismic load than Category I and II buildings. Category IV buildings are designed for a 50-percent higher load.

Our group also looked beyond the building code to buildings that have functions that we believe are vital to the seismic resilience of the state as a whole. Supermarkets, pharmacies, some big-box retail stores, and banks comprise a subset of buildings that will be relied upon heavily following a disaster. The importance of having an ample supply of basic provisions—such as food, water, medical supplies, and money—in affected areas after a natural disaster has been underscored by many previous events, including Hurricane Katrina and the 2011 Tohoku earthquake and tsunami in Japan. If buildings that house these resources are not seismically resilient, the ability of the community to recover after the event will be adversely affected. For these reasons, the community’s large retail buildings and bank buildings have been classified as critical buildings in this study.

OCCUPANCY CATEGORY	NATURE OF OCCUPANCY
I	Buildings and other structures that represent a low hazard to human life in the event of failure, including but not limited to: <ul style="list-style-type: none"> • Agricultural facilities. • Certain temporary facilities. • Minor storage facilities.
II	Buildings and other structures except those listed in Occupancy Categories I, III and IV
III	Buildings and other structures that represent a substantial hazard to human life in the event of failure, including but not limited to: <ul style="list-style-type: none"> • Buildings and other structures whose primary occupancy is public assembly with an occupant load greater than 300. • Buildings and other structures containing elementary school, secondary school or day care facilities with an occupant load greater than 250. • Buildings and other structures containing adult education facilities, such as colleges and universities, with an occupant load greater than 500. • Group I-2 occupancies with an occupant load of 50 or more resident patients but not having surgery or emergency treatment facilities. • Group I-3 occupancies. • Any other occupancy with an occupant load greater than 5,000^a. • Power-generating stations, water treatment facilities for potable water, waste water treatment facilities and other public utility facilities not included in Occupancy Category IV. • Buildings and other structures not included in Occupancy Category IV containing sufficient quantities of toxic or explosive substances to be dangerous to the public if released.
IV	Buildings and other structures designated as essential facilities, including but not limited to: <ul style="list-style-type: none"> • Group I-2 occupancies having surgery or emergency treatment facilities. • Fire, rescue, ambulance and police stations and emergency vehicle garages. • Designated earthquake, hurricane or other emergency shelters. • Designated emergency preparedness, communications and operations centers and other facilities required for emergency response. • Power-generating stations and other public utility facilities required as emergency backup facilities for Occupancy Category IV structures. • Structures containing highly toxic materials as defined by Section 307 where the quantity of the material exceeds the maximum allowable quantities of Table 307.1(2). • Aviation control towers, air traffic control centers and emergency aircraft hangars. • Buildings and other structures having critical national defense functions. • Water storage facilities and pump structures required to maintain water pressure for fire suppression.

a. For purposes of occupant load calculation, occupancies required by Table 1004.1.1 to use gross floor area calculations shall be permitted to use net floor areas to determine the total occupant load.

Figure 4.1: Oregon Structural Specialty Code, Table 1604.5

Past earthquakes have brought to light the dangerous nature of unreinforced masonry (URM) and non-ductile concrete structures. Because of their tendency to sustain excessive damage or even collapse in

moderate earthquakes, these buildings pose the greatest threat to life safety of any other building type in the state of Oregon. This, along with the fact that URM and non-ductile concrete buildings can be found in all occupancy categories, was the main reason that our task group included these vulnerable buildings in our study of critical buildings.

Building Data and Analysis

After identifying the building sectors, the task group went on to identify data sources for the existing building stock that could be used for assessment of the buildings' seismic resilience. Two sources were used:

- The *2007 Statewide Seismic Needs Assessment: Implementation of Oregon 2005 Senate Bill 2 Relating to Public Safety, Earthquakes, and Seismic Rehabilitation of Public Buildings* (Open File Report 07-020) prepared by the Oregon Department of Geology and Mineral Industries (DOGAMI), hereafter referred to as the 2007 SSNA.
- The Hazus Earthquake Model developed by the Department of Homeland Security and FEMA, hereafter referred to as FEMA Hazus.

The 2007 SSNA is an assessment of existing hospitals, police and fire stations, emergency operations centers, and K-12 schools throughout Oregon. This assessment was conducted using a rapid screening method developed by FEMA to identify potential seismic hazards. The report provides evaluations of each facility, which were visited by screeners to establish a Rapid Visual Screening (RVS) score based on the FEMA 154 methodology. The data was compiled by DOGAMI, and the resulting scores were then reviewed by the structural engineers in our task group, who, in the case of emergency operation centers, police stations, fire stations, and acute care hospitals, reviewed the screening for every building and converted the RVS scores to *expected recovery* scores. These scores were then placed into the overall *Critical Building Target States of Recovery Matrix* shown in Figure 4.2. A similar procedure was also used for schools, but because of the number of school buildings, only about 10 percent of the total school building stock was reviewed directly. Additionally, the task group took into consideration tsunami inundation, liquefaction, and landslides, which were not a part of the DOGAMI study.

To assess residential buildings, community retail centers, banks, critical government facilities, and vulnerable buildings, data for expected damage estimates based on a Cascadia subduction zone event were extracted from the FEMA Hazus model, and an analysis was performed to develop *expected recovery* scores, which were then added to the overall matrix shown in Figure 4.3. Unlike the 2007 SSNA data, which looked at each individual building, the FEMA Hazus model utilizes a complex series of statistical analyses to predict damage estimates. This involves making predictions about the quantity, size, and construction of buildings in various sectors based on census data, and then calculating an expected performance for these buildings using additional statistical models. While this is a useful tool for looking at large populations of buildings, the outcomes do not correlate directly to any specific buildings. Because more detailed reports were not available, this data was used to establish *expected*

recovery scores; these are subject to a larger variation in expected results and should not be viewed with same level of reliability as those in Figure 4.2. Recovery scores developed from the 2007 SSNA report have been separated from the scores developed through the use of FEMA Hazus due to the differences between the two sources.

Target States of Recovery

With recovery scores established, the next step was to determine the recovery state that should be targeted in planning the path to statewide seismic resilience. The recovery state is the average time that should be needed to repair a building in a given sector and restore most of its functionality. For the Phase 1 target states, which are measured in hours, there is not much differentiation in the building performance, though it should be realized that just evaluating buildings, particularly in the areas most severely affected, may take several days. Buildings with Phase 2 response times are expected to require some repairs, but generally should not sustain major damage to the primary structures. Phase 3 buildings are expected to sustain significant damage, likely requiring many months to a year or more to repair. The worst building performance—expected of structures in the 18 month and 36+ month categories—will likely be at, or near, a complete loss. Many buildings can be reconstructed in 18 months with sufficient resources; the remaining collapsed buildings will likely require 36+ months.

The determination of target states was based mostly on assessing the relative importance of each of the occupancy types to the response and recovery effort after the seismic event. Buildings that house first responders or provide emergency functions are the most vital to the response effort and will need to be functional immediately after the seismic event occurs. Schools in the affected areas need to provide a level of life-safety protection for the children and adults in them during the earthquake, but could be out of service for up to 60 days without significant impacts on resilience. The exceptions are those schools designated as emergency shelters for displaced citizens after the event occurs. The availability of food, water, medical supplies, and money will also be critical to the speed of recovery of the communities affected by the seismic event. Consequently, retail centers, pharmacies, and banks will have to be able to return to normal operation in a reasonable amount of time. All of these considerations informed the development of the *target recovery* scores for each building class that are reflected in Figures 4.2 and 4.3. Note that a specific target state was not determined for vulnerable buildings. This is because the use and function of these structures varies widely. Instead, the recovery state should either match the building's occupancy category, if the building is used for a critical function, or upgrade criteria should be established based on the needs of the facility—but these criteria should not be less than life safety.

With both expected and target recovery states identified and tabulated for each building class by seismic region, the gaps between expected and target building performance can easily be seen.

Assessment of Current Building Performance: A Sector by Sector Review

EMERGENCY OPERATIONS CENTERS, POLICE AND FIRE STATIONS

Introduction

In 2005, the Oregon Department of Geology and Mineral Industries (DOGAMI) published a report titled *Statewide Seismic Needs Assessment: Implementation of Oregon 2005 Senate Bill 2 Relating to Public Safety, Earthquakes, and Seismic Rehabilitation of Public Buildings, Report to the Seventy-Fourth Oregon Legislative Assembly*. This report catalogued the vast majority, if not all, of the emergency operations centers, police stations, and fire stations within Oregon. Of the sources of data collected, 82 emergency operations centers, 109 police stations (which includes city police, state police, and county sheriff), and 595 fire stations (which includes city and rural fire protection districts) provided enough information for the Critical Buildings Task Group to reasonably assess the state of seismic resilience of each of these buildings.

Most of the buildings considered by the task group are one- or two-stories tall and are constructed from reinforced masonry or wood. The median building age is approaching 40 years. Despite the good performance record of wood structures during earthquakes, the age of these buildings and the low level of seismic design used prior to 1995 places the older structures at risk. Additionally, a number of buildings located in the coastal region are at risk of earthquake-caused tsunami inundation or large ground displacements due to either liquefaction or landslides. A number of buildings in the valley region are also at risk of significant movement due to liquefaction or landslides resulting from an earthquake. All of these factors increase the level of risk for many buildings exposed to the effects produced by a Cascadia subduction zone event.

Estimated State of Recovery

The expected state of recovery of these buildings ranges from a few buildings remaining fully functional during and immediately following a Cascadia subduction zone event, to many other buildings requiring three or more years for repair before they are deemed fully functional or are demolished. Of particular concern are the buildings along the Oregon coast, where 82 percent of the emergency operations centers, 86 percent of the police stations, and 67 percent of the fire stations will most likely take 18 months or more to resume normal operations. The buildings within the valley zone are also problematic, with 27 percent of the emergency operations centers, 38 percent of the police stations, and 31 percent of the fire stations likely to sustain damage to the extent that 18 months or more will most likely be required to resume normal operations. Therefore, instead of being able to withstand and operate during and after a Cascadia subduction zone seismic event, which is what we should expect of buildings performing these vital life-safety functions, it is anticipated that a significant percentage of the buildings that house these types of essential services will not be functional for some time after the event. Of significant concern is the longer recovery time anticipated for many of the critical buildings that are located along the coast and in portions of the valley.

Target State of Recovery

The importance of emergency operations centers, police stations, and fire stations to the post-earthquake response and recovery is widely recognized. Building codes have required for some time that these facilities be designed to a higher standard, with the intent that they will remain operational after a major earthquake. The public also recognizes that these facilities are the centers for first response, and there is consequently a general expectation that they will remain functional after the disaster. For these reasons, the target state of recovery for these facilities must be *Event Occurs* as indicated in the recovery matrix, Figure 4.2.

Sector Specific Recommendations and Conclusions

To our knowledge, a mandatory program with a formal mechanism to identify deficient structures and require their upgrade with a firm timeline does not currently exist. ORS 455.400 requires seismic rehabilitation of publicly-operated emergency operations centers, police stations and fire stations by 2022, but with the caveat of being, “subject to available funding.” As a result, it appears to have had only limited effect in this and other essential and critical building sectors. Typically, the impetus to evaluate these types of buildings to determine their seismic-resisting capability is motivated at the local level, often by the public agency itself. Once the evaluation has been completed, a determination can be made about whether a particular building or group of buildings requires seismic rehabilitation. The agency will then submit a request to the voters within that community to support a general obligation bond to accomplish the needed work. This was recently done within the city of Portland, where a general obligation bond was passed in 1998 to rehabilitate the city’s fire stations (See Figure 4.4). The last fire station rehabilitation was completed in 2012.



Figure 4.4: Some cities in Oregon have already started seismic rehabilitation program to strengthen the fire stations that are susceptible to serious damage in an earthquake. Fire Station #1, the largest in Portland, was retrofitted in 2009. It should now be in working order after an earthquake, serving downtown Portland. (Source: Peck Smiley Ettlin Architects)

Financing methods for the rehabilitation of public buildings are much more limited than the opportunities that exist for privately-owned buildings. As a result, general obligation bonds, or some variation thereof, are likely to be the primary method to finance the seismic upgrading of these critical facilities. Oregon Senate Bill 3 and 5 (2005) provided for the establishment and funding of a grant program for emergency services buildings to assist with upgrades of these facilities, but funding to date for this program has been limited. Public buildings ultimately must be financed, either substantially or completely, with public funds. This can only happen by implementing a broad program of education to inform the voters of the risks associated with these seismic hazards and the impact that those risks, if unmitigated, will have on their communities when the Cascadia subduction zone event occurs.

In addition to the types of public buildings discussed above, other types of critical government facilities exist, including, but not limited to, city halls, public safety answering points (PSAPs, usually termed 911 Centers), and jails. The 2007 SSNA report did not collect data on these types of facilities, and to our knowledge, no publicly-available data exists about them within Oregon, except for broad statistical data which can be inferred from the FEMA Hazus data discussed in the *Critical Government Facilities* section of this chapter (see below). Consequently, no specific, data-driven recommendations regarding the seismic resilience of these other critical government facilities have been provided as part of this report.

EDUCATION FACILITIES

Introduction

Public school facilities make up a special category of Oregon's public infrastructure. Oregon has 1,355 K-12 public schools organized in 197 school districts that are overseen by independent elected local school boards. Combined, these schools have a total of over 2,000 buildings of various structural types, sizes, and vintages, including numerous buildings that are more than a century old.

Schools are among the most heavily used public buildings in Oregon and one of a few classes of buildings whose occupants' presence is compulsory. In 2010, the Western States Seismic Policy Council (WSSPC) adopted a policy recommendation that states, "Children have the right to be safe in school buildings during earthquakes" (WSSPC, 2010). Based on the findings of the Critical Buildings Task Group, the state of Oregon is far from meeting this ideal of student safety today.

The 2007 Statewide Seismic Needs Assessment (SSNA) employed the FEMA 154 Rapid Visual Screening (RVS) methodology to characterize the structural performance of buildings by placing them into one of four broad categories of collapse potential. Of the full sample of 2,018 K-12 educational facilities assessed using the FEMA 154 methodology, 12 percent rated Very High, 35 percent rated High, 23 percent rated Moderate, and 30 percent rated Low collapse potential (Lewis, 2007). The assessment focused on school facilities constructed before 1994, although some more recent buildings were included. Of the buildings assessed, roughly 80 percent were built before Oregon first adopted a statewide building code in 1971, and 60 percent are more than 50 years old. The assessment revealed

that inadequate or non-existent seismic design is pervasive in every region of Oregon, and that seismic retrofit investment at the school district level has been limited.

Schools are typically large, complex buildings with plan irregularities that will be sources of poor seismic performance. Many schools are campuses that are comprised of multiple buildings of varying sizes and construction dates, and often varied construction materials. Primary, K-8, and high schools generally consist of one- or two-story wood-frame or concrete masonry unit (CMU) and concrete buildings with flexible roof diaphragms. One- to three-story lightly-reinforced concrete buildings braced by concrete shear walls, concrete tilt-up buildings, and unreinforced masonry (URM) buildings are also common.



Figure 4.5: The previous Molalla High School building, a three-story unreinforced masonry structure, was damaged from the M5 .6 Scotts Mills, Oregon earthquake in 1993. It happened during spring break, when the school was empty, which prevented serious injuries. The district took the opportunity to forecast future needs and decided not to rebuild at the same location. Molalla High School is now housed on a larger campus with a stronger, more spacious building. Many URM schools and other buildings in Oregon could suffer a similar fate in future earthquakes. Communities can act now to plan how and when to rehabilitate or replace these aging, potentially dangerous facilities. (Source: DOGAMI)

The building stock of Oregon’s K-12 schools possesses seismic vulnerabilities that are common to the specific building types of which it consists. Unreinforced masonry (URM) buildings historically perform poorly in seismic events and are the most dangerous existing building type in the school building stock (See Figure 4.5). Many 1930s-era multistory schools rely on lightly-reinforced concrete shear walls that are historically poor performers as well. Wood framed schools should perform well provided they are well constructed, even though many of them pre-date building codes. These wood buildings may possess deficiencies, including weak or missing roof-to-wall connections, and weak or missing anchorage of walls to foundations—all of which could contribute to poor seismic performance. Concrete tilt-up buildings have also proven to perform poorly in earthquakes. Newer tilt-up buildings have been improved by code changes adopted following the 1994 Northridge earthquake in California, but older tilt-up buildings, and even CMU buildings, may remain vulnerable due to poor connections between heavy rigid walls and flexible roofs. Modular classrooms may also be vulnerable, because they may have insufficient connections to their foundations. In addition, many schools contain unsecured and inadequately braced nonstructural components that may present falling hazards during a seismic event (See Figure 4.6).



Figure 4.6: Pendant light fixtures failed in this elementary school library during the 1983 M6.5 Coalinga, California earthquake. If the room had been occupied, this could have caused injuries. Bracing nonstructural elements in homes, schools, and offices can often be done easily and relatively inexpensively. (Source: NOAA/NGDC, Earthquake Engineering Research Institute)

Estimated State of Recovery

The 2,377 educational facility records in the 2007 SSNA were too numerous to be analyzed individually by members of the educational facilities subgroup. Our analysis and results are based on a random sample of approximately 300 records (224 primary school buildings and 79 secondary school buildings) that were selected as representative of the broader data set. We classified the building records into the appropriate geographic seismic zone (coast, valley, and eastern) and verified that we had assembled an adequate sample size for each zone.

Our analysis revealed that in a Cascadia subduction zone earthquake scenario, pervasive structural vulnerabilities would likely result in recovery durations of 18 months or longer for primary and secondary schools in the seismic zones of the coast and valley. Primary and secondary schools in the eastern seismic zone are expected to have recovery times of 60 days or less, mainly due to the minimal level of ground motion expected in that geographical area.

Target States of Recovery

Giving consideration to the prioritized needs of the entire community for resilience and recovery, returning children to school within 30 days is preferred. However, it was also the opinion of the task group that a disruption of the public education system for up to 60 days could be tolerated without having a major impact on communities and students. This determination was based on several considerations:

- School buildings will not initially be as critical to the recovery as most other critical buildings included in our study. The exception to this would be those schools that are needed as emergency shelters, and as such, should have a target state of recovery of 72 hours.
- Teacher/employee contracts can be adjusted to accommodate a 2 month stoppage of work more readily than employee contracts in many private businesses.
- Temporary facilities, including portable buildings and large buildings that are undamaged after the event, can be employed to serve some of the more immediate needs of education until full recovery is achieved.

Discussion and Sector Specific Recommendations

Oregon's K-12 educational facilities have been the focus of seismic rehabilitation policy efforts for more than a decade. In 2001, legislation (ORS 455.400) directed that, subject to available funding, K-12 educational facilities with seismic deficiencies should be rehabilitated to a life-safety performance level by 2032. In 2002, Oregon voters adopted ballot measures amending Oregon's constitution with Articles XI-M and XI-N, provisions that allow the state to issue general obligation bonds for the purpose of seismic retrofits to existing schools and emergency response facilities. In 2005, a series of bills (Senate Bills 2, 3, 4, and 5) directed DOGAMI to organize and conduct the *Statewide Seismic Needs Assessment*,

directed Oregon Emergency Management to establish a seismic rehabilitation grants program, and allowed the Department of Administrative Services and the Oregon State Treasurer to issue bonds to finance seismic rehabilitation.

In 2007, Senate Bill 1 provided funding to establish and staff the seismic rehabilitation grants program. The first opportunity to authorize a bond sale for an inaugural round of seismic retrofit grants came in the 2009-2011 biennium. The legislative assembly authorized \$30 million for seismic grants, divided equally between the program for K-12 schools and the companion program for emergency response facilities. The first round of K-12 grants directed \$5.6 million to projects at twelve schools in eight school districts in the spring of 2010. As the recession deepened, the governor chose to rescind \$7.5 million of the original authorization for the program, limiting additional granting during 2009-2011. Three additional seismic grants were awarded to K-12 schools (including two URM buildings) in early 2011. These grants marked the end of the first funded cycle of the program.

On the final day of the 2011 legislative session, the legislature authorized \$7.5 million in new seismic grants for K-12 schools during the 2011-2013 biennium. These grants, announced in Fall 2011 and funded by a bond sale in July 2012, directed \$7.2 million to seven K-12 schools. To date, the Seismic Rehabilitation Grants Program has funded retrofit projects at 22 schools, about 2 percent of the need documented by the *Statewide Seismic Needs Assessment*.

During the short 2012 session of the legislative assembly, legislators passed Senate Bill 1566. The bill directs the state's Department of Education, which communicates with parents about student achievement and school performance via an annual report card, to inform the public in that report that a database of seismic ratings exists and to provide a web link to the ratings. Further, the bill asks school districts to advise DOGAMI when they rebuild or renovate schools, so that the state can share information about the upgrades. The first reports submitted by individual school districts are now posted on the DOGAMI website, although the agency has no funding to integrate information from the reports in an update of the statewide database itself.

Given both the limited impact that existing policies have had on restoring resilience in Oregon's schools and the uneven success that Oregon school districts have had passing local capital bond measures for school rehabilitation and construction in recent years, an evaluation of Oregon's approach to characterizing and addressing the seismic vulnerability of school facilities is in order. Past outreach using the results of the *Statewide Seismic Needs Assessment* has emphasized the threat to life safety and the possibility of mass casualties in collapsed school buildings. By contrast, the gap analysis we have performed as part of this resilience study focuses on quantifying the state's ability to resume public education after a region-wide Cascadia subduction zone earthquake, given what is known about the condition of the state's school facilities. With the anticipated level of damage to those facilities, the disruption of public education could extend considerably beyond a full school year, particularly in the coast and valley regions—a factor that could impede Oregon's economic and social recovery for years after the Cascadia subduction zone earthquake.

HEALTHCARE FACILITIES

Introduction

There are 60, mostly privately-owned, healthcare facilities within the state of Oregon, with the majority of the buildings being over 40 years old. Each healthcare facility is comprised of either a single building or multiple buildings that form a campus. Roughly 180 structures within all of the 60 healthcare facilities serve critical healthcare functions. There are additional buildings within each healthcare facility's campus that have not been included in this study because they do not serve acute care needs and are not considered essential.

In essential healthcare buildings, the most prevalent construction material is concrete, with approximately 70 percent of concrete structures relying on concrete shear walls to resist lateral loads and the remaining structures relying on concrete moment frames. The second most prevalent construction material is steel: approximately an equal distribution using steel braced frames and steel moment frames to resist lateral loads. Reinforced masonry and wood are seen more often in the smaller structures located in the coastal or eastern zones.

The most notable structural lateral-system vulnerabilities found within healthcare facilities are the non-ductile concrete and non-ductile steel frame buildings. These building structures were typically constructed before the increased seismic risk in Oregon was well understood in the early 1990's, and before substantial code changes were made to require more robust connections that are better able to resist seismic forces.

Independent of the type of lateral system, two very notable structural irregularities that typically create problems were found in many of the healthcare buildings. The first is a horizontal irregularity in the footprint of the building. Seismically, the most reliable shape for a floor plan of a building is a square or a rectangle. The least reliable shapes are T, E, L, and X configurations or variations of these. In association with these irregular shapes, many problems occur at parts of the structure called *reentrant* or *interior* corners, which do not occur in a rectangular floor plan. The second notable structural irregularity is a vertical irregularity, which occurs when the building steps back in plane as the floor levels increase.

Historically, performance of healthcare facilities around the world has been extensively affected by nonstructural damage. The ability of a healthcare facility to function is greatly dependent on the nonstructural items within that facility. The building's structure may perform very well during the expected earthquake, but the hospital might not be functional after such an event due to nonstructural damage alone. Nonstructural vulnerabilities typically includes lack of proper anchorage of mechanical, electrical, and medical equipment and lack of proper bracing of ceilings, pipes, ductwork, electrical elements, medical gas such as oxygen, and other critical service lines. Healthcare facilities are often campuses made up of multiple buildings, which include those that provide healthcare and often a central utility plant (CUP) or a central building that contains a large number of pieces of essential equipment (such as boilers and air handling units) that support the rest of the campus. Although this

central building may not provide healthcare directly, it is considered a vulnerability, because damage to its structure and contents can have a great impact on the entire campus' utilities and ability to function.

Estimated State of Recovery

Currently, essential healthcare facilities in Oregon are not expected to perform well during a Cascadia subduction zone seismic event. The facilities on the coast and in the valley will likely take over three years to recover to an operational state. Some facilities in eastern Oregon will take approximately 30 days to recover to an operational state.

Target State of Recovery

Essential healthcare facilities are critical for the life safety of the entire population and must be capable of surviving the expected Cascadia subduction zone seismic event. This survival requires that the buildings remain completely functional during the event and be available to respond to emergency needs immediately following the earthquake and any aftershocks that may occur. For these reasons, the target state of recovery for these facilities must be *Event Occurs* as shown in the Recovery Matrix.

Sector Specific Recommendations

As outlined in the 2011 Oregon Revised Statutes (ORS 672.107), *significant structures* must be designed under direct supervision of a licensed structural engineer. Hospitals and other major medical facilities that have surgery and emergency treatment areas are considered *significant structures* or *essential facilities* according to ORS 455.447. Standby power generating equipment for essential facilities is also considered *essential* and is covered under ORS 672.107. However, buildings that contain the balance of equipment required to keep these vital facilities functional are not considered *essential*, and therefore are typically designed to a lesser seismic standard. In order for critical healthcare facilities to be truly resilient, all buildings that provide mechanical, electrical, and plumbing service to the buildings must be designed to the same standard. This shift will require revisions to the building code and an expanded definition of *essential facility*.

In 2001, legislation (ORS 455.400) directed that, subject to available funding, acute inpatient care facilities that are determined to pose an "undue risk to life" should be rehabilitated to a life-safety performance level by 2022. Currently, to our knowledge, most of the deficient acute care facilities in the state have not been upgraded in accordance with this legislation. By having the "subject to available funding clause" in the statute language, the legislation does not provide a mandate and therefore is not proving to be effective in addressing the problem. A more effective mandate should include specific measures that would give private healthcare systems incentives, whether tax credits or some other vehicle, to make seismic improvements.

A facility's buildings and internal infrastructure are not the only factors to take into consideration when assessing the facility's ability to operate without interruption after the expected Cascadia subduction zone seismic event. Healthcare facilities are also dependent on the city for their water, on distribution-center buildings for supplies, and on roadways for the delivery of supplies, to name only a few things.

Healthcare facilities do not have control over any of these components. It is therefore recommended that healthcare facilities maintain a minimum thirty-day supply of all items that come from external sources; this should include water, fuel, and medical supplies.

EMERGENCY SHELTERING

Shelter as an essential part of disaster recovery and resilience, and the need for it is great. Many facilities throughout the state are listed as designated emergency shelters by local jurisdictions and the state Office of Emergency Management. The most common buildings on these lists are schools and churches, followed by other miscellaneous buildings (including community centers) that have the capacity to hold large numbers of occupants. The expected and target states of recovery for school buildings can be found in the *Education Facilities* section of this chapter (above). As with all building sectors, the performance of churches and other facilities in a Cascadia subduction zone event will be a function of the building's vintage, construction type, and geographical location. In general, the expected and target states for churches should, at a minimum, match those of school facilities with similar construction.

Discussion of recommendations for buildings designated as emergency shelters can be found in the *Conclusions and Recommendations* section at the end of this chapter.

CRITICAL GOVERNMENT FACILITIES

Introduction

Critical government facilities are those buildings that are necessary to the continuing operation of essential services following a significant event. The most obvious of these—police stations, fire stations, and emergency operations centers (EOC)—are addressed separately in this report. Other services, however, which may include some limited administrative functions and essential health services, and certain structures, such as correctional facilities and even the maintenance buildings that are needed for repairing roads and utilities following the earthquake, are also necessary. Compiling a specific list of these services and their associated facilities was beyond the scope of this report—but in many ways, such a list was not necessary to get a general overview of how these facilities may perform.

Estimated State of Recovery

Data for general government facilities was available from the FEMA Hazus damage estimates and was reviewed to determine the resilience scores included in the resilience matrix. The statistical analysis from Hazus was based on an estimated 2,357 government buildings located throughout the state—this estimate represents the total number of government buildings, not all of which are critical to statewide resilience. We assumed that both the non-critical buildings and the remaining critical buildings (those not included in the assessment of police, fire, and EOC facilities) will generally behave in a similar manner. We were therefore able to determine with reasonable certainty the level of performance that can be expected.

The construction types anticipated by Hazus statistics are primarily steel and concrete prior to 1950, with about 20 percent of the inventory being shared between wood and unreinforced masonry (URM). These construction types change for construction periods between 1950 and 1970. The post-1970 distribution still anticipates concrete and steel, as well as some wood, but much more prevalent is reinforced concrete masonry (CMU), which is now estimated to comprise about 25 percent of the building stock.



Figure 4.7: Several states have rehabilitated their state capitol buildings. The Utah State Capitol was seismically retrofitted with base isolation to protect visitors and occupants and preserve historic fabric in the building. (Source: State of Utah)

Target State of Recovery

The target states of recovery for these facilities will vary depending on the facility. An average target state was estimated to be 30 days, although the task group recognized that some buildings may need to be immediately serviceable (correctional institutions, for instance), while other critical functions may not be immediately needed and could wait several weeks before coming back into service. It will be necessary for the state and local governments to determine which functions are critical for resilience and then inventory and evaluate the associated facilities, before eventually prioritizing and upgrading the deficient structures.

RESIDENTIAL HOUSING

Introduction

Following an earthquake, people must have shelter—it is one of the basic elements required for resilience. In some cases, such as when a person’s residence has been damaged and is not safe to occupy or when people are temporarily unable to reach their homes, this need may be met by emergency shelters. Emergency shelters, however, cannot provide for everyone. For a large segment of the population, primary residences must serve as shelters, although in many cases, they will be without power and running water. In the absence of such residential shelters, the humanitarian needs of the population following a large earthquake grow tremendously. Post-earthquake response can also be impeded if emergency responders must first devote time to finding shelter and safety for their own families before they are available to help others.

In the state of Oregon, single-family residential homes make up the largest portion of residences, and therefore, potential shelters. The U.S. Census data for 2010 place the number of residential dwelling units in Oregon at approximately 1.6 million. FEMA’s Hazus program, which was used for this review, estimates that there are approximately 960,000 single-family homes; this is generally consistent with similar census estimates.

Construction of single-family homes is almost entirely of light wood framing. Historically, these buildings have generally performed well in seismic events. One- and two-story wood frame buildings are relatively light-weight compared to other structures, and will usually see larger forces from a design-level wind storm than from a significant earthquake, since seismic forces are (in part) a function of the structure’s weight.

However, the details of a wood frame structure’s construction have a lot to do with its ability to withstand earthquakes, and certain common vulnerabilities make these buildings susceptible to earthquake damage, particularly if they were built before 1976. One of the most common deficiencies is a lack of adequate anchorage between the upper wood frame structure and the concrete foundation or basement walls. Another common deficiency can result in the failure of cripple walls, which are short wood framed wall segments that typically extend from a foundation to the floor above. Frequently, these lack proper connections and can easily rotate in a manner similar to a hinge, allowing the building to shift laterally off of its foundation (see Figure 4.8). In older structures, unreinforced masonry chimneys can fall and cause additional structural damage.

Multifamily housing is also at risk. Depending on construction type and size, these buildings will typically have more seismic risk compared to single-family homes. Construction of multifamily buildings ranges from light wood frame construction, unreinforced masonry, to steel and concrete. The apartment buildings built of unreinforced masonry apartment buildings are particularly vulnerable.



Figure 4.8: This residential building shifted on its foundation after the 1989 M 7.1 Loma Prieta, California earthquake. (Source: NOAA/NGDC, C. Stover, U.S. Geological Survey)

Estimated State of Recovery

Using statistical data from FEMA’s HAZUS program, the task group reviewed estimated damage data for single-family residences. The average estimated recovery duration for residences on the coast was less than 30 days, which may be low considering the intensity and duration of ground shaking that will likely result from a Cascadia subduction zone event in this area. In the valley, the estimated recovery duration is 72 hours, which again may underestimate the damage. The eastern zone is expected to have negligible damage (again based on the Hazus estimates). These results are compared with a target state of recovery of 30 days, which is based on the need for shelter as an essential part of disaster recovery and resilience.

The recovery time of multifamily housing was not reviewed by the task group. Recovery time for smaller light wood framed buildings will be similar to single family homes. Larger buildings of other construction types will have longer recovery times. The loss of low income multifamily housing will affect economic recovery.

Sector Specific Recommendations

Improving existing structures will require significant education of homeowners, who need to understand the risks, the potential costs, and the steps necessary to evaluate and correct deficiencies. Additionally, common structural deficiencies should be noted during home inspections at the time of purchase. It is

likely that homeowners will bear the majority of the expenses for upgrading deficient structures; however, financial incentives, such as tax credits and low interest loans, might be considered to encourage improvements if future evaluations, based on more complete data, show unacceptable damage estimates.

Outreach should seek to provide education and resources for homeowners. A number of such tools are already available, though not widely known. FEMA provides a number of publications on their website for homeowners, such as FEMA-530 Earthquake Safety Guide for Homeowners. The City of Portland has also created a guide, *Brochure #12-Residential Seismic Strengthening – Methods to Reduce Potential Earthquake Damage* and provided additional information on the Bureau of Development Services website at www.portlandoregon.gov/bds.

COMMUNITY RETAIL CENTERS AND BANKS

Introduction

There are thousands of community retail centers and banks within the state of Oregon. These types of facilities have been deemed critical buildings because of their importance to the post-disaster recovery of communities throughout the state. The most important of the many community retail buildings in the state are large supermarket and pharmacy chain stores, which have large inventories of supplies that will be in high demand following a disaster. Many of these large chains have remote storage and distribution centers that will be of equal importance for supplying goods to damaged communities. Banks also have an important role in Oregon's seismic resilience, as they will be critical to processing vital financial transactions for businesses and consumers as they recover from the disaster. Although many banks have emergency response plans in place, if the buildings they are housed in perform poorly during an earthquake, overall resilience will be compromised.

FEMA's Hazus analysis includes a wide variety of commercial buildings, including some overlap with other structures evaluated separately in this report using different analysis methods. However, part of this large group of commercial buildings includes wholesale and retail buildings and banks, which were reviewed to estimate the resilience of these structures. A specific estimate of building quantities for this subset was not available, but the statistical analysis considered their construction types, general age, and historical performance. The number of retail and bank buildings in each county was assumed to be proportional to the overall distribution of commercial buildings.

Structural Vulnerabilities

The construction types anticipated statistically by Hazus for retail buildings vary with the building's age. Prior to 1950, wood, steel, concrete, concrete masonry (CMU), and even unreinforced masonry (URM) were common. As construction practices changed, buildings shifted toward larger stores, and the post-1970 Hazus statistics reflect this, with greater use of CMU and concrete, including precast (or tilt-up) construction which began to see much wider use after 1970. Statistics for bank buildings also reflect

some similar shifts in construction, moving away from steel and unreinforced masonry after 1950 and toward more wood frame, CMU, and concrete construction.

Today, most big-box stores, supermarkets, distribution warehouses, and pharmacies are housed in concrete masonry (CMU) or tilt-up concrete structures with light-framed wood or steel roofs. Buildings of this type that were constructed prior to 1995 have historically not performed well in earthquakes. The seismic vulnerabilities of these buildings were highlighted in the aftermath of the 1994 Northridge earthquake. The most prominent structural failure in this building type has been the connection between the light framed roof and the relatively heavy exterior walls, which led to partial or full roof collapse (see Figure 4.9). Building code provisions for the design and construction of the roof/wall connections were enhanced following the Northridge earthquake, with requirements for a higher degree of resistance being incorporated in the 1997 UBC and subsequent building codes. As a result, buildings of this type that were built after approximately 1995 should have a higher degree of resilience than those built prior to that year.



Figure 4.9: Several tilt-up concrete panels of this construction material supply store in Concepcion fell away from the building, causing the roof framing to collapse after the M 8.8 February 27, 2010 Maule Chile earthquake. (Source: Kent Yu, Degenkolb Engineers)

Banks are different from big-box stores in that they are housed in a multitude of structures, including stand-alone one-story wood framed buildings, unreinforced masonry or non-ductile concrete buildings, and steel and concrete high-rise buildings. The seismic performance of these buildings will vary based on their location, vintage, and construction type; however, structural vulnerabilities are present to some degree in a large percentage of the existing building stock.

During an earthquake, many existing community retail and bank structures could also suffer extensive damage to nonstructural elements and components within the buildings. Nonstructural elements include, but are not limited to, mechanical, electrical, and plumbing systems and associated equipment, lighting fixtures, suspended ceiling and soffit systems, and unsecured storage racks and display shelving. These elements can be a falling hazard during a seismic event, impeding occupants from safely exiting the building, disrupting the operation of the facility, and extending the time it will take to restore the building to normal operation.

One unique aspect of retail and bank buildings is that they are almost exclusively privately owned. This makes establishing and enforcing building seismic upgrade requirements and mandates for these occupancies particularly difficult.

Estimated State of Recovery

The expected average time of recovery to normal operation for community retail big-box, supermarket, and pharmacy buildings after a Cascadian subduction zone seismic event is four months for Oregon's coastal region and 30 days for the valley region. The recovery duration for these types of buildings in eastern Oregon is expected to be nominal, mainly due to their distance from the earthquake source.

The recovery time for bank buildings after the Cascadia subduction zone seismic event is estimated at 60 days for Oregon's coastal region and 30 days for the valley region. As in the case of the community retail centers, the recovery duration for banks in eastern Oregon is expected to be nominal.

A critical aspect of the resilience of this building class is the degree to which the business' ancillary facilities, provided they are not located within the high seismic hazard zone, can provide support to and replacement of the functions of the damaged facilities. While this aspect was not considered in our analysis, it is possible that the actual impact of the Cascadia subduction zone event on the functionality of these buildings could be lessened if protocols are in place to replace their functions remotely. Additionally, it should be noted that the efficiency of the distribution of goods, services, and medical prescriptions to the general public has increased with the advent of one-stop-shop, big-box retailers that typically occupy newer tilt-up concrete or masonry (CMU) structures that have been designed and built to more stringent seismic code requirements. It is likely, however, that after the Cascadia subduction zone seismic event, the inventory in these facilities will be quickly depleted, so overall seismic resilience will depend upon the condition of ancillary facilities, including distribution warehouses, data centers, roads, bridges, and highways.

Target State of Recovery

The suggested statewide target state of recovery for community retail centers and banks is 30 days. This timeframe is primarily due to the importance of having goods, services, and medical prescriptions available to the general public after a significant seismic event. The assumption behind this target is that facilities in areas unaffected by the earthquake will be able to fill the needs of the public remotely until the damaged buildings can be repaired. This target state is also consistent with both the performance expectations behind code provisions for new buildings of this occupancy category and the recommendations of the Business Continuity Task Group that took part in the development of Oregon's resilience plan.

Sector Specific Recommendations

As community retail centers and banks are normally privately owned, the ability to mandate building upgrades with public funding is minimal. Therefore, seismic upgrades of deficient existing buildings will most likely need to be incentivized through tax credits or other similar means. Mandates, tax credits, and other incentives (whether singly or in combination) should also be developed to require or strongly encourage the building owners and tenants to properly brace and anchor deficient nonstructural elements within their buildings, as it is anticipated that nonstructural damage resulting from the Cascadia subduction zone earthquake will have a significant impact on the seismic resilience of these building types.

For the existing building stock in this sector, the redundancy of critical business continuity elements, such as distribution of goods and data, remote accessibility and support, and availability of personnel, should be assessed by each company. This redundancy is vital to achieving the 30-day target state of recovery over the entire state of Oregon.

Finally, improving awareness—both within businesses and among the general public—of the seismic vulnerabilities of the existing community retail centers and banks is critical to moving toward a more resilient Oregon. Developing a seismic resilience rating for existing retail and bank building stock could serve as an effective tool for these businesses as they select buildings to lease or prioritize buildings for upgrades. As part of this rating program, common seismic vulnerabilities could be explained in layman's terms, in an effort to improve public awareness and understanding of Oregon's current seismic resilience status.

VULNERABLE BUILDINGS

Introduction

For the purposes of this evaluation, vulnerable buildings are defined as unreinforced masonry (URM) and non-ductile concrete structures. These building types are classified as critical buildings in this study because they represent the most significant threat to life-safety and historically exhibit extremely poor performance in seismic events (see Figures 4.10 to 4.12). URM buildings are constructed with clay brick, hollow clay tiles, or concrete block, with little or no reinforcement. Most of these buildings in Oregon

were originally built prior to 1940, and the majority has undergone no seismic improvements since they were constructed. Non-ductile concrete buildings have been historically susceptible to extreme damage in moderate to severe seismic events and have very little steel reinforcement. These buildings range in age from 40 to 100 years and are generally one to five stories in height. These vulnerable buildings represent a building *type* rather than an occupancy *use* and, as such, they can be found in many occupancy uses, including essential facilities (such as fire and police stations), retail centers, restaurants, residential buildings, and commercial office buildings.



Figure 4.10: Christchurch Cathedral of the Blessed Sacrament, New Zealand after the M 7.0 September 3, 2010 Darfield earthquake [Source: NOAA/NGDC, Steve Taylor (Ray White)]



Figure 4.11: The fourth-story wall of this unreinforced masonry building on Bluxome Street in San Francisco collapsed onto the street, killing five people in their cars, during the M7.1 October 18, 1989 Loma Prieta, California earthquake. (Source: NOAA/NGDC, E.V. Leyendecker, U.S. Geological Survey)



Figure 4.12: This non-ductile concrete frame medical building collapsed during the 1994 M6.8 Northridge, California earthquake. (Source: NOAA/NGDC, J. Dewey, U.S. Geological Survey)

Estimated State of Recovery

Based on the limited information available for these types of buildings throughout the state (other than those that were already addressed in the other occupancy use categories discussed above), recovery timelines were estimated based on FEMA Hazus data provided by the Oregon Department of Geology and Mineral Industries (DOGAMI). Categories included URM buildings only; specific data was not available for non-ductile concrete structures. Hazus software operates through a geographic information system (GIS) to display earthquake hazard information, inventory data, and estimated losses, which approximate building damage from a particular seismic event. The Hazus data used for this study was based on a Cascadia subduction zone earthquake as well as the age and construction type of the buildings. In addition, the Hazus data assumes that all structures were designed prior to the incorporation of seismic provisions in the building code.

As expected, the data in Figure 4.3 indicates that most of these buildings will experience either significant structural damage or partial to total collapse. Accordingly, most of the vulnerable building stock in the coastal and valley regions will require major repairs or wholesale replacement. Buildings in eastern Oregon will experience ground shaking levels similar to or greater than those that URM buildings experienced during two previous Oregon earthquakes: Scotts Mills and Klamath Falls. Because the Cascadia subduction zone earthquake will likely be of much longer duration than these two previous events, it has the potential to cause even more damage. For this reason, the expected recovery duration for vulnerable buildings in eastern Oregon was determined to be 30 days.

It should be noted that these recovery times are based on a Cascadia subduction zone earthquake, which may not result in the highest possible ground shaking intensities in some parts of the valley and eastern Oregon, but would likely have a longer duration. Other hazards, such as soil liquefaction, landslides, and tsunamis, were considered in the projected states of recovery. DOGAMI's recent studies indicate that soil hazards exist in all three regions of the state, and many coastal regions are located in a tsunami inundation zone, which increases the vulnerability of these buildings.

Because hard data related to nonstructural components in vulnerable buildings was not readily available, the performance of these components was not a consideration in determining the recovery scores. It is likely, however, that the damage to the primary structure of these buildings will override that of nonstructural components in terms of effect on resilience.

Target State of Recovery

As mentioned above, vulnerable buildings can be found in many different building occupancy uses. Consequently, the reader should refer to the *Target State of Recovery* discussions in the occupancy-based sections of this chapter to develop an understanding of the gap between the projected and recommended performance of these buildings.

Codes, Past Legislation, and Funding Sources

A few jurisdictions have adopted code language mandating seismic upgrades for these types of buildings (primarily URMs) to varying degrees. For legislation, or funding sources, refer to each sector-specific section of this chapter and to the following recommendations.



Recommendations

Recommendations are provided below for Oregon’s critical and vulnerable structures with the goal of achieving a resilient state. In making these recommendations, the task group recognized that not all buildings are critical and necessary to achieve resilience. Many buildings are expected to perform reasonably close to their target states in the eastern part of the state, where the seismic design category is low. Residential buildings are expected to perform reasonably well, although older homes need to be tied to their foundations and older multi-family buildings are at risk.

Leadership and resources are needed for adopting standards and policies, evaluating and inventorying buildings, and rehabilitating structures. Creating a State Resilience Office that could outline the steps required for creating seismic resilience, should be a priority. This Office can take into consideration the gaps between existing and target states of recovery and critical building functions. It can also coordinate with resiliency efforts in the other sectors (such as transportation, energy, etc.)

It is imperative, however, that implementation and funding for seismic resilience not be delayed while we wait for a full inventory, definition, and budgeting of the problem. More than enough is already known to begin making strides toward resilience. Whether the journey before us is a thousand miles or ten thousand miles, we should start moving forward now; additional inventories and studies should be made as we progress along the way.

IMMEDIATE ACTIONS

► Establish a State Resilience Office

- *Finding:* The State does not currently have person or office to provide the resources and leadership necessary for coordinating and implementing a statewide seismic resilience plan.
- *Recommended:* Establish and fund a State Resilience Office(r) to provide leadership, resources, advocacy, and expertise in implementing a statewide resilience plan.

► Prioritize Education

- *Finding:* There is a great need for education and awareness of the impact of a Cascadia subduction zone event, and how to prepare Oregon to be resilient to that impact.
- *Recommended:* Programs should be encouraged and implemented to provide a broad range of education, public awareness, and public relations regarding Cascadia subduction zone risks and State resilience.

► Complete an Inventory of Critical Buildings

- *Finding:* A complete statewide inventory of critical buildings does not exist, but is needed for future planning, assessment and upgrading of critical building structures.
- *Recommended:* An inventory, compiled within five years, should include an initial seismic screening of each building and updates to the existing inventory. More detailed evaluations should be completed for those buildings identified by the initial screening to be the most susceptible to damage from an earthquake.

► Include Inspection in Emergency Response

- *Finding:* There will be immediate demand for safety inspections of critical buildings (both public and private) following a Cascadia earthquake.
- *Recommended:* Strengthen the existing database of ATC-20 certified post-earthquake inspectors, establish procedures for their engagement and response following an event, and strengthen Good Samaritan laws to protect them. Expand database and training for ATC-45 of certified post flood and wind inspectors.

SUSTAINED ACTIONS

► **Prioritize Essential Facilities**

- *Finding:* The estimated current state of hospitals, Emergency Operation Centers, fire and police stations falls significantly short of the target state need for these facilities to be immediately available following the CSZ event.
- *Recommended:* Hospitals should be upgraded within 15 years of completing an inventory and seismic evaluations. Emergency Operation Centers, fire and police stations should be upgraded within 20 years if the building is a URM or non-ductile concrete structure, or 30 years if it is of other construction. Non-structural elements in these buildings should also be upgraded within the same timeframes, and ORS 455.400 should be strengthened and updated for consistency with these recommendations. Create publicly accessible database that shows annual seismic performance data for essential facilities.

► **Fully Fund the Seismic Retrofit of K-12 Schools**

- *Finding:* The current average estimated state of recovery for K-12 school facilities in the Coast and Valley regions of Oregon falls significantly short of the recommended target state, despite an existing statute directing seismic retrofit by January 1, 2032.
- *Recommended:* Fully fund state investment in seismic retrofit of schools; prioritize the replacement of structure types that present the greatest hazard to their occupants in a seismic event; promote ASCE- 31 (or equivalent) engineering assessment of existing school facilities; and update the state's database of public school facilities on a regular basis.

► **Expand the Passive Trigger Seismic Strengthening Program**

- *Finding:* The existing building code includes triggers that require building upgrade for a change of occupancy or increase in structural loads, but does not go far enough, allowing major building upgrades to deficient structures without requiring seismic strengthening.
- *Recommended:* Encourage local jurisdictions to adopt the triggers for seismic upgrade to include changes in the level of occupancy risk, major building renovations, and re-roof of URM and non-ductile concrete buildings. Give seismic upgrades the highest priority for non-conforming upgrades, and allow them to be phased over 10 years if needed.

▶ **Accelerate the Retirement or Full Upgrade of Vulnerable Buildings**

- *Finding:* Unreinforced Masonry (URM) and non-ductile concrete buildings are generally the most dangerous types of buildings in an earthquake, and should not be allowed to remain in service indefinitely unless they are fully upgraded.
- *Recommended:* Initially, the danger of URM and non-ductile concrete buildings should be disclosed at the time of building sale or lease. Through market pressures and upgrades triggered by other building repairs and changes, upgrades can be made to many of these structures.

▶ **Improve Plan Review and Construction Oversight**

- *Finding:* Structural plan reviews are often performed by individuals who would not otherwise be qualified to provide the design being reviewed. Special inspections and structural observations are not currently required by code for certain structure types and structural elements important for resilience.
- *Recommended:* Require a licensed design professional or structural engineer provide plan reviews for critical buildings (Cat. 3 & 4) reciprocal with the licensing required to provide the design. Strengthen state building code to expand Special Inspections and Structural Observations to include special inspections and structural observations for most commercial structures, critical non-structural components, and wall connections in tilt-up and CMU buildings with light framed roofs and floors.

▶ **Introduce an Earthquake Performance Rating System**

- *Finding:* Public knowledge of the seismic safety of the buildings they own, live in, and work in is often limited, or misinformed, especially in comparison with public awareness of other hazards.
- *Recommended:* Encourage and promote a voluntary, standardized rating system for the expected earthquake performance of buildings, similar to the LEED rating used for green buildings. The system should be easily understood and readily available to anyone with an interest or stake in the building.

▶ **Incorporate Resilience into Performance-Based Design**

- *Finding:* Many new buildings will be constructed over the next 50 years, but current code is only intended to protect the life safety of occupants, not ensure resilient performance.

- *Recommended:* Adopt incentives to encourage owners to build to performance standards that exceed the “code minimum.” Support research aimed at better tools and criteria for performance based design.
- ▶ **Encourage seismic retrofit of existing homes and multi-family buildings.**
- *Finding:* Many residential homes built before 1976 have vulnerabilities to earthquakes and the damage may result in them being unusable or in need of costly repairs. Many older multi-family buildings are at risk as well.
 - *Recommended:* Adopt seismic retrofit programs and incentives to encourage homeowners to tie their older homes to their foundations, and encourage the seismic retrofit of multi-family buildings.

References

1. Western States Seismic Policy Council (WSSPC) (2010). "Identification and Potential Mitigation of Seismically Vulnerable School Buildings," Policy Recommendation 10-8. Broomfield, CO: WSSPC Annual Business Meeting.
2. Lewis, D. (2007). *Statewide Seismic Needs Assessment: Implementation of Oregon 2005 Senate Bill 2 Relating to Public Safety, Earthquakes, and Seismic Rehabilitation of Public Buildings* (Open File Report 07-020). Portland, OR: Department of Geology and Mineral Industries. (DOGAMI). Online: <http://www.oregongeology.org/sub/projects/rvs/default.htm>
3. Oregon Legislative Assembly (2012). Senate Bill 1566. Relating to Seismic Information about Schools. Sponsored by Sen. Peter Courtney. Online: <http://leg.state.or.us/12reg/measures/sb1500.dir/sb1566.en.html>
4. Seismic Rehabilitation Task Force created by Senate Bill 1057 (1996). *Seismic Rehabilitation of Existing Buildings in Oregon*. Report to the Sixty-Ninth Oregon Legislative Assembly, September 30, 1996, p.13 item B.
5. Seismic Rehabilitation Task Force created by Senate Bill 1057 (1996). *Seismic Rehabilitation of Existing Buildings in Oregon*. Report to the Sixty-Ninth Oregon Legislative Assembly, September 30, 1996, p.38, item C, and Appendix E.

5. Transportation

Introduction

Emergency response, access to critical buildings, the restoration of utilities, and the reopening of businesses all depend on the transportation network. The resilience of the transportation network is considered a key factor for re-establishing other lifelines after a major Cascadia subduction zone earthquake.

To assess the status of the various modes of transportation and determine appropriate levels of resilience, a task group consisting of representatives of each mode of transportation, including highways, rail, airports, water ports, and transit, along with representatives of local agencies, met in person monthly and worked extensively outside these meetings to develop and collect data and formulate a plan that will help increase the survivability of citizens and critical features of the built environment.

GOALS

The overall resilience goal for the transportation network is first to facilitate immediate emergency response, including permitting personnel to access critical areas and allowing the delivery of supplies, and second to restore general mobility within specified time periods for various areas of the state. In order to establish specific resilience goals in support of this larger objective, the task group assessed the transportation network in four geographical areas:

- The tsunami inundation zone along the coast (based on DOGAMI maps).
- The coastal zone (the area outside of the tsunami zone, from the Oregon coastline to the summit of the Coast Range).
- The Willamette Valley zone (from the summit of the Coast Range to the summit of the Cascades).
- The central Oregon zone (east of the Cascades summit).

In addition, the task group established resilience targets for transportation facilities. These targets align with a phased, three-tiered approach to the restoration of the transportation network. The main factors in forming this approach were the need to optimize post-earthquake response for our state and the need to establish priorities for making future investments to achieve the targets. Similar to the Oregon Seismic Lifeline Routes identification project, the task group prioritized highways into three tiers: Tier 1 is a small backbone system that allows access to all vulnerable regions, major population centers, and areas considered vital for rescue and recovery operations. Tier 2 is a larger network that provides access to most urban areas and restores major commercial operations. Tier 3 is a more complete transportation network.

Resilience targets were further established at three levels:

- **Minimal.** A minimum level of service is restored, primarily for the use of emergency responders, repair crews, and vehicles transporting food and other critical supplies.
- **Functional.** Although service is not yet restored to full capacity, it is sufficient to get the economy moving again—for example, some truck/freight traffic can be accommodated. There may be fewer lanes in use, some weight restrictions, and lower speed limits.
- **Operational.** Restoration is up to 90 percent of capacity: A full level of service has been restored and is sufficient to allow people to commute to school and to work.

THE TASK GROUP'S OBJECTIVES

In developing a resilience plan for transportation, the task group's objectives were to:

- Summarize the state of our knowledge about the seismic ground shaking and tsunami inundation risks of various transportation modes.
- Estimate the ability of each mode to recover following a major earthquake.
- Develop recommendations for strategically focused retrofit solutions. For example, one of the recommended solutions proposed in the plan includes a program of prioritized investments over a 50-year period to achieve the desired level of operation after a major Cascadia subduction zone event. (The plan considers all modes of transportation to maximize both access to and the utility of the network, while minimizing the level of investment.)

THE TRANSPORTATION SYSTEM'S ROLE IN STATEWIDE RESILIENCE

A resilient transportation network is critical for re-establishing other lifelines, such as water, electricity, fuel, communication, and natural gas, after the earthquake. For example, a resilient transportation system allows repair crews to access and reconnect water pipes and power lines more quickly, and it provides access to much needed fuel and supplies.

Given the transportation system's current state of vulnerability to ground shaking and tsunami inundation, initial damage from a Cascadia subduction zone earthquake is expected to be devastating to the parts of the system located along the coast and in western Oregon. The resulting lack of mobility will have direct impacts that severely limit rescue operations, inspection of critical infrastructure, restoration activities, and the state's ability to restore services leading to recovery. The widespread damage and lack of access to many parts of western Oregon will be partially mitigated by disaster preparedness planning, but that effort will be hampered by the lack of access to disaster areas after the event, which could limit the ability of emergency responders to save lives, facilitate evacuation, and manage critical infrastructure.

To collect and develop the information used for this report, the members of the Transportation Task Group consulted transportation providers and collected data on potential infrastructure damage and the

state of preparation and availability of trained, experienced personnel to manage transportation systems in the aftermath of a major earthquake. Keeping in mind that the core objective of the plan is to better support both immediate statewide post-earthquake/tsunami response and longer-term recovery and construction, the task group considered both emergency response actions and various ways to improve the resilience of the transportation network. This included strengthening or armoring existing systems, adding new facilities that will withstand seismic loads and motions, moving facilities out of tsunami inundation zones, and identifying alternate means to provide service. Resilient transportation systems planning must address all facets of the problem in order to provide for effective and efficient movement of goods and people after a large seismic event—an event that is expected to cause widespread damage to the built environment as well as significant reconfiguration of the natural environment.

THE TASK GROUP'S APPROACH

The task group's general approach in developing the transportation section of the Oregon's resilience plan was to use existing emergency operations or response plans and any existing programs for strengthening facilities and other assets within the various modes. The task group used existing plans for strengthening and armoring transportation systems. This chapter includes a section on each mode, covering response for life safety and recovery, and a section on strengthening and armoring options. The task group also considered the interdependencies among the various modes and the relevance of these interdependencies for response, recovery, and strengthening. Finally, a summary of known gaps in available data and a list of recommendations are provided to identify next steps in the transportation sector. These recommendations reflect the need to determine the most cost effective solutions to reduce interruptions in service and increase mobility immediately after an event and during long term recovery. An example of a fully developed assessment of a mode, including retrofitting recommendations and cost estimates, is provided in the 2012 Oregon Seismic Lifeline Routes identification project and ODOT Seismic Options Report.

Assessment of Transportation Performance

When a large earthquake is triggered within the Cascadia subduction zone, the result will be widespread disruption of the transportation system. This disruption will make rescue operations in many areas difficult, if not impossible, and will have an immediate, disruptive impact on the economy. The majority of bridges and other transportation infrastructure in western Oregon are susceptible to serious damage in a major seismic event, because they were built before modern seismic codes were in place. Dozens of unstable slopes and pre-existing deep slides are expected to fail under the extended three minutes or more of shaking that will accompany a large Cascadia event, further impacting our mobility by closing roads.

Modern seismic codes were developed in the late 1980s and early 1990s. The extended period of strong shaking from a Cascadia subduction zone event will damage many masonry and other structures built prior to modern seismic codes. Homes, hospitals, businesses, schools, and other critical structures that

have not been seismically retrofitted may collapse or be severely damaged, killing or injuring many people. The injured will need immediate attention, but may be stranded due to the lack of mobility.

Our knowledge of the locations of faults and the geological history of major events in Oregon is very recent. Although Oregon has low seismicity in comparison to California and Washington, there is potential for less frequent—but much larger and more damaging—earthquakes than the crustal earthquakes that have occurred regularly in those states. Oregon has not yet seen the effect of a large damaging earthquake, and ODOT has so far expended minimal resources on seismic retrofitting. As a result, much of Oregon’s highway system will not be usable immediately after a major seismic event.

Because the impacts will be widespread, a Cascadia earthquake and tsunami have the potential to cause unparalleled economic and human catastrophe for the state of Oregon. The issue is *when not if* the state will have a major damaging seismic event. The question is whether we will be effectively prepared to rescue our citizens and recover economically without the use of a continuous connected transportation system. Aftershocks and movement of historic slides will complicate rescue and extend recovery times.

The task group recognized that failure of a major dam would lead to additional impacts to transportation that were not explicitly considered in our study. Like much of our other infrastructure, it is assumed that most of the power generation and flood control dams in Oregon were constructed prior to consideration of modern seismic provisions. Well-constructed dams have fared well in other subduction zone events, however, so failure may not be likely in Oregon. Damage to spillway gates, on the other hand, may lead to unexpected water release, and the resultant flooding would compound damage from a Cascadia subduction zone event.

Highway Transportation

Because most of Oregon’s highways were constructed before design codes considered the potential Cascadia subduction zone effects, many bridges and unstable slopes are vulnerable to severe damage. The chart below shows the age-related vulnerability of Oregon’s bridges.

Resilience targets for mobility on highways vary from zone to zone and from tier to tier within the same zone. For example, a Tier 1 route in central Oregon is expected to be resilient within three days, whereas a Tier 3 route may take up to four weeks. Similarly, a Tier 1 route within the coastal zone is expected to become resilient within seven days, whereas a Tier 3 may take up to three months or more. The detailed range of targets is shown in the tables titled *Oregon Transportation Resilience Status* in Figure 5.22.

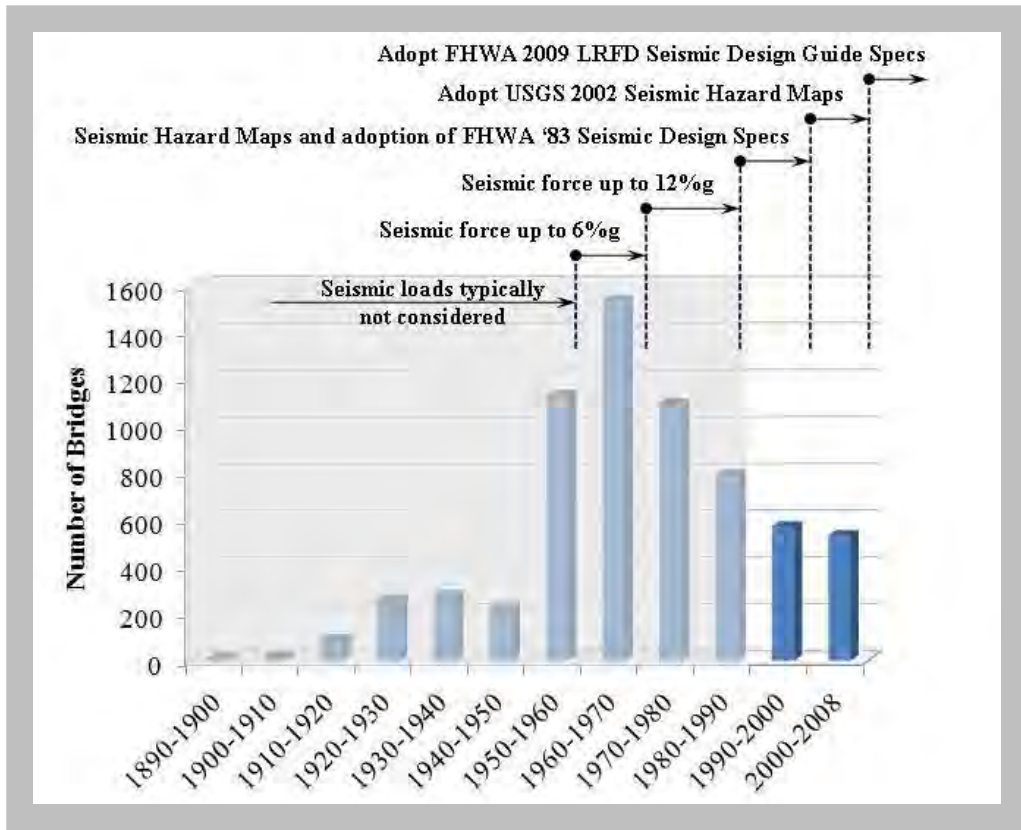

Figure 5.1: Oregon Bridge Seismic Design History (Source: Peter Dusicka, PSU)

The vulnerabilities of Oregon’s bridges are complex and differ from bridge to bridge and from site to site. Some bridges are prone to more than one type of seismic deficiency, and a few may need to be replaced. ODOT has already conducted research and investigation to develop the best approach for mitigating the problem. Worldwide experience has shown that, while we are not knowledgeable enough to predict the exact time that an earthquake will strike, we can be proactive to save lives and speed up the recovery process.

The following photos and diagrams describe some of the most common vulnerabilities of highway bridges and one of the possible retrofits to mitigate that type of failure.

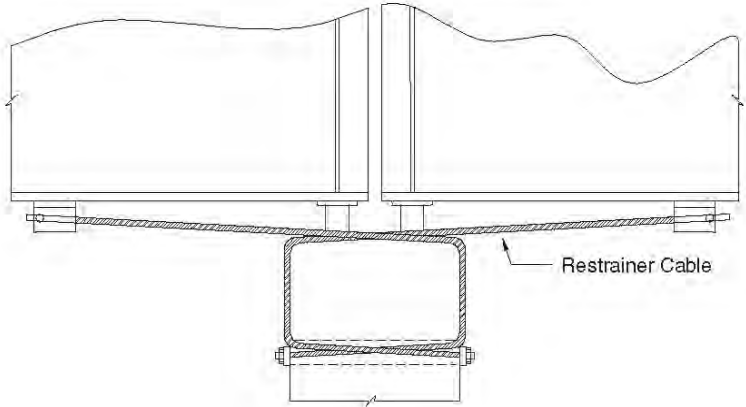
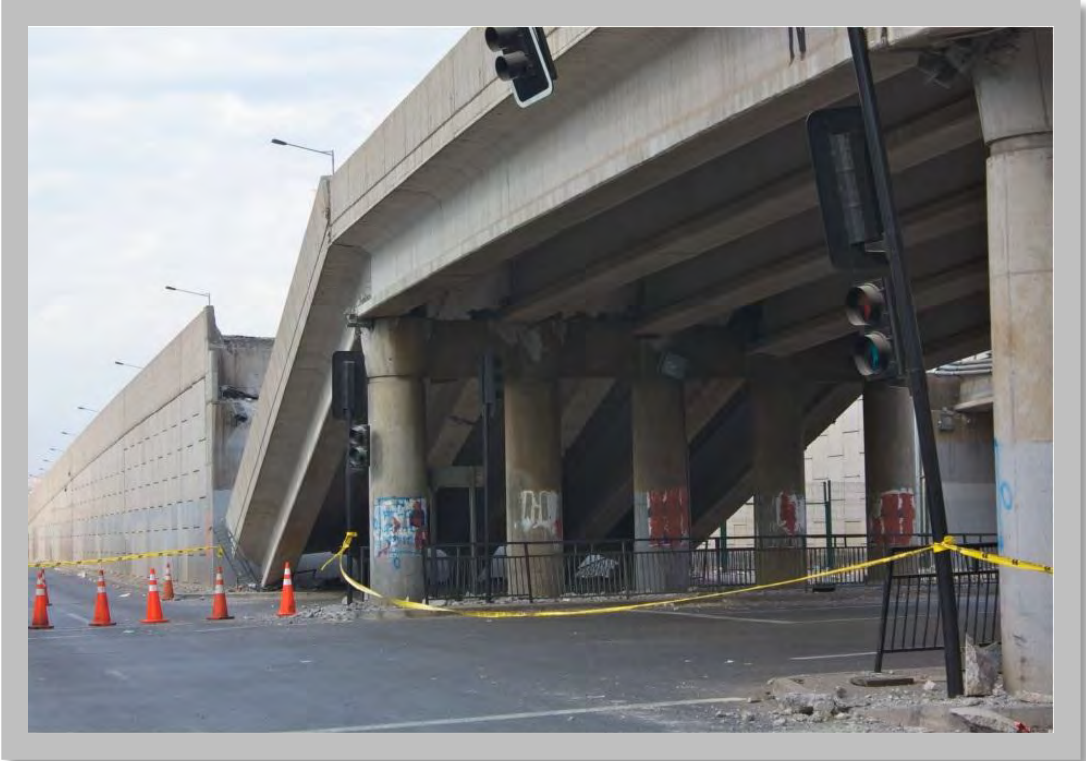

Figure 5.2: Restrainer cables will prevent bridge superstructure fall-off. (Photo Source: Flickr.com)

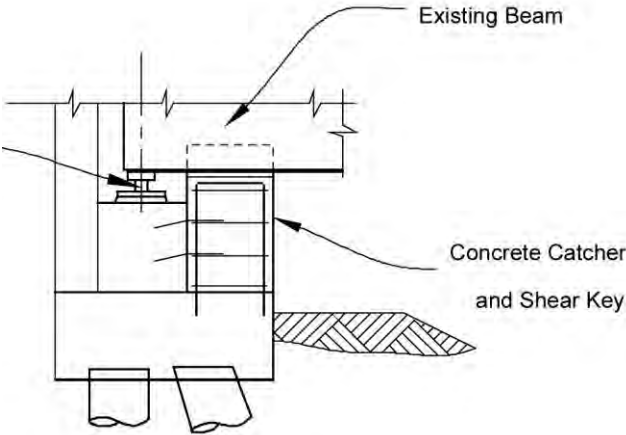
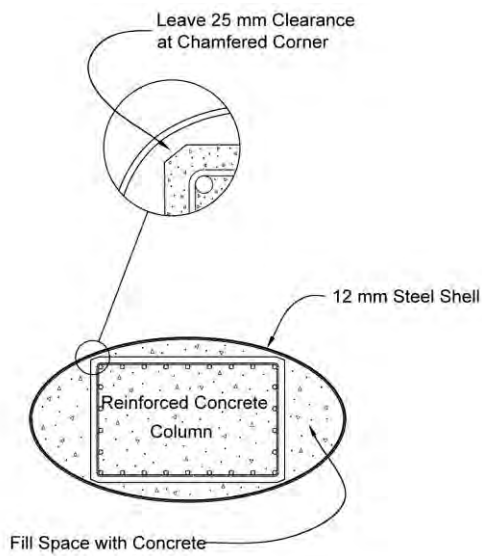
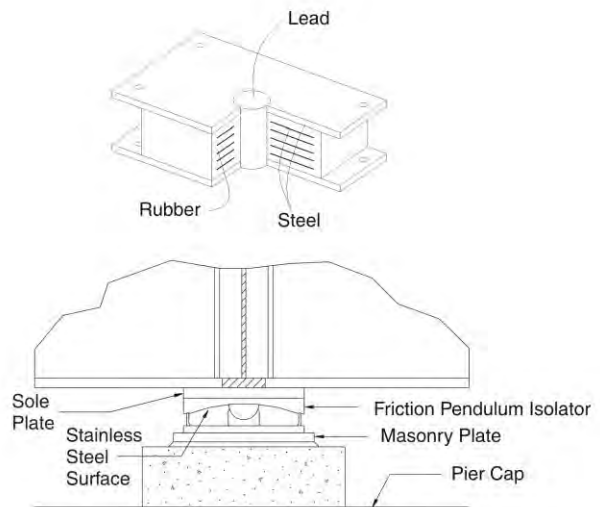

Figure 5.3: Shear Keys will restrain the superstructure transversally during an earthquake.
(Photo Source: www.fhwa.dot.gov)



a) Steel Shell Casing



b) Isolation Bearings

Figure 5.4: Preventing the Column Damage by: a) Steel Shell Casing and b) Isolation Bearing
 (Photo Source: ace-mrl.engin.umich.edu)

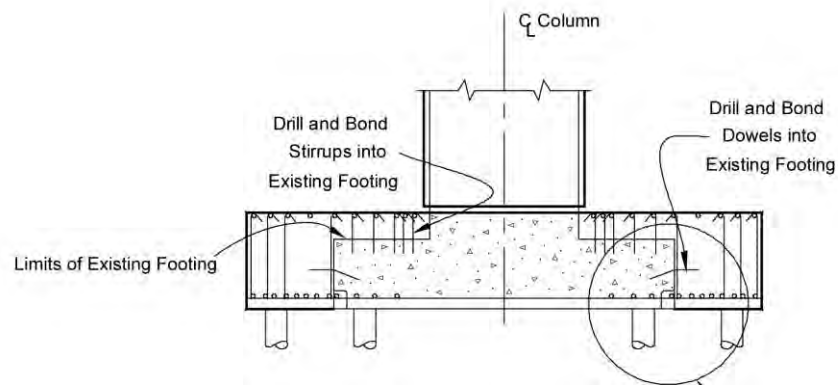

Figure 5.5: Strengthening the foundation or soil mitigation will prevent the damage to the bridge substructure due to liquefaction and lateral spreading (Photo Source: www.fhwa.dot.gov)

LOSS OF MOBILITY AFTER A MAJOR SEISMIC EVENT: BRIDGES

The combination of very strong and prolonged ground shaking, followed closely by a powerful and damaging tsunami—and by multiple strong aftershocks in the succeeding days and months—makes the Cascadia subduction zone earthquake the most dangerous natural hazard for Oregon, especially for Oregon’s coastal communities. The ground shaking will cause destruction of buildings and roads, downed power lines, blocked streets, ruptured gas lines (resulting in explosions and fires), and broken water and sewer lines, creating a largely uninhabitable environment in many areas.

Oregon, or even the entire nation, has never witnessed a disaster of this magnitude in modern history; therefore, we can only speculate about how this event will impact Oregonians. Unlike other crises, such as a highway crash or a house fire, in which fire trucks and ambulances will arrive within a few minutes to rescue people in need, the situation after a Cascadia subduction zone earthquake will involve disruptions of emergency services along with everything else. There will not be enough firefighters to assist every household or business, nor enough medical staff to help every injured person, nor enough police officers to go door to door reminding people to be calm and quickly move to higher ground to avoid the oncoming tsunami. In order to gain some insight into what would happen after a major

Cascadia subduction zone earthquake, we can look at a very similar situation elsewhere: the earthquake and tsunami in Japan on March 11, 2011 (see Figure 5. 6).

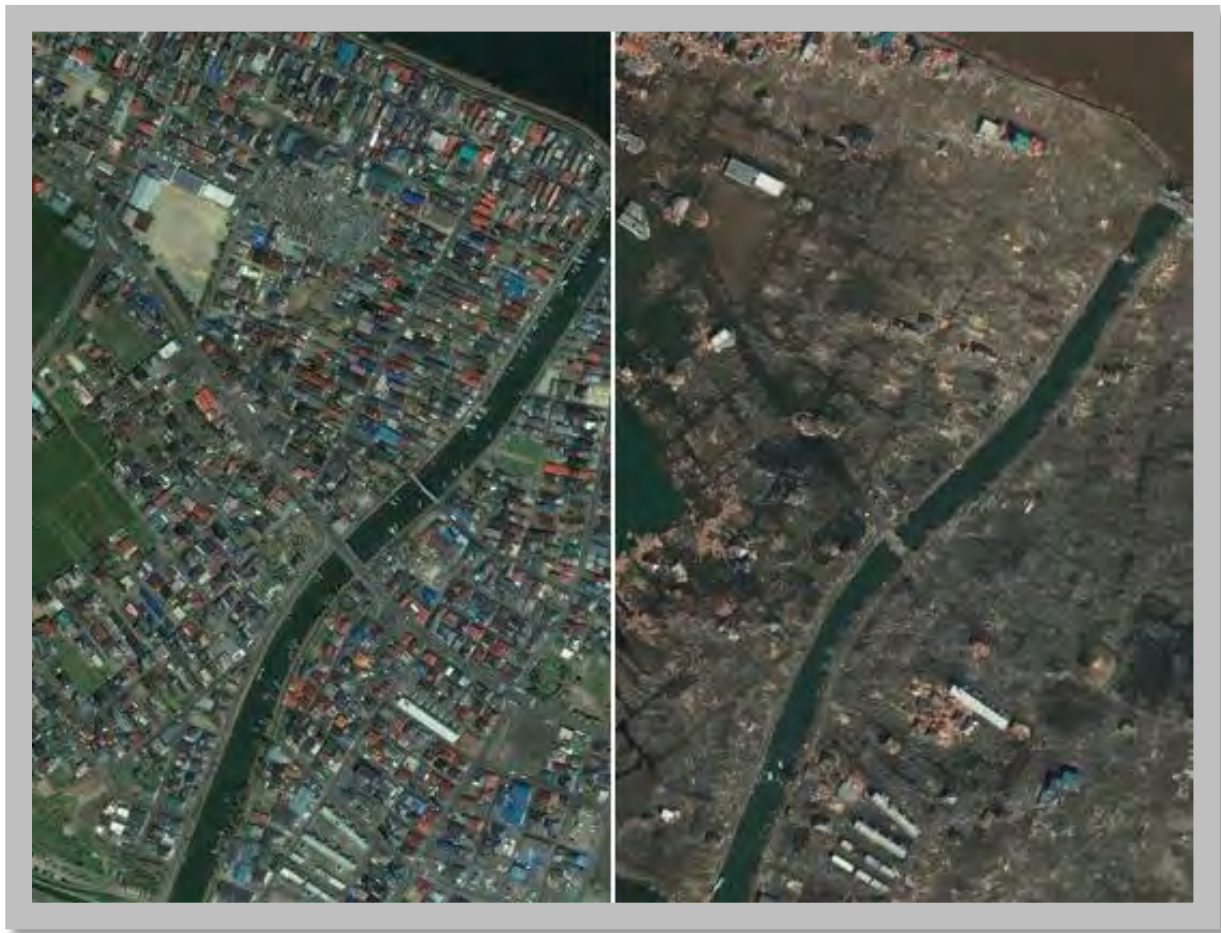

*Figure 5.6: Before and after the March 11, 2011 earthquake and tsunami in Japan
(Source: cbsnews.com)*

Coastal Area Impacts

Assuming most of our citizens have a basic understanding about the effects of a subduction earthquake, a massive movement of people away from the coast is expected. Acknowledging that no immediate help will be available, many people will try to drive away from shore and out of reach of the tsunami—but, our transportation network will not be able to handle this huge, confused and panicked traffic. Coastal residents have been advised to get away from the shore on foot, but tourists and commercial travelers are not likely to know that.

For most of Oregon’s coastal cities, U.S. 101 serves as the main route to other destinations. Unfortunately, after a Cascadia subduction zone earthquake, most of this route will be impassable. Most bridges carrying U.S. 101 were not designed for seismic loading and will suffer major damage under the expected ground shaking. Many other bridges, if they survive the shaking itself, will be washed away by

the tsunami. In addition to the bridge damage, many highway segments are expected to become heavily damaged and impassible due to landslides. The latest assessment of state-owned bridges in Oregon shows that of 135 total bridges carrying U.S. 101, 56 bridges are expected to collapse, and 42 bridges will be heavily damaged. Some of these bridges are signature bridges and registered as historic.

East-West Corridor Impacts

East-west corridors between the coast and the Willamette Valley are the next tier of alternatives for people escaping from the disaster zone and for emergency crews responding to impacted areas. Unfortunately, the bridges on these corridors are also vulnerable to ground shaking, landslides, and liquefaction of supporting soils, so it is likely that these segments will not all be passable. The overall condition of bridges on these routes is moderately better than those carrying U.S. 101; however, there are many weak links along these routes that will make them impassable as well.

Route	Total No. of	Bridges	Heavily
U.S. 30 (Hwy 92)	27	6	3
U.S. 26 (Hwy 47)	52	3	10
OR 99W & OR 18 (Hwy 91 & Hwy 39)	35	5	4
OR 34 & U.S. 20 (Hwy 210 & Hwy 33)	42	7	3
OR 569 & OR 126 (Hwy 62 & Hwy 69)	50	9	9
OR 38 (Hwy 45)	19	1	3
OR 42 (Hwy 35)	47	23	5

Figure 5. 7: Vulnerability of Bridges on East-West Corridors (Source: ODOT – Bridge Section)

Because of the terrain these highways were built on, many of them lack options for detouring traffic around a bridge that collapses. The situation can become even more critical if the earthquake strikes during winter, when many of the state’s secondary routes experience seasonal closure. Figure 5.7 shows the results of an inventory and damage assessment of state bridges located along the major routes connecting U.S. 101 to Interstate 5, when subjected to a Cascadia subduction zone event.

Interstate 5 and Mid-Willamette Valley Impacts

Interstate 5 (I-5) will also have some major problems after a Cascadia subduction zone earthquake. With the majority of bridges on I-5 built just before the modern seismic design specifications were developed, the most important segment of Oregon’s transportation network may be fragmented, with some areas not operational after such an earthquake, depending upon the intensity and epicenter of the quake and its aftershocks. During the recent Oregon Transportation Investment Act (OTIA) program, ODOT was

able to replace many deficient structures along this route; however, the main criterion for the selection of these bridges was the need to support current truck load requirements, and not necessarily to meet current seismic standards. Thus, several bridges that already have been identified as vulnerable to earthquake shaking are still in active service. From a total of 348 bridges carrying both northbound and southbound traffic, five bridges are expected to collapse and 19 bridges to be heavily damaged during the Cascadia subduction zone event.

Interstate 5 is expected to be the main corridor of traffic flow after the Cascadia subduction zone event. Because of its location and capacity, and because U.S. 101 is expected to be impassable, I-5 will become the critical backbone route for emergency response after the earthquake. To the extent I-5 is operable, emergency support can be staged along the corridor, and responders will be able to reach the coastal cities either through the east-west corridors (once these corridors become accessible) or by other means.

Interstate 5 becomes an even more important route during the statewide recovery effort. Many scientists believe that the Cascadia subduction zone event will be a mirror image of the 2011 Tohoku earthquake that hit Japan. This means that most of our coastal cities will be heavily damaged, and restoring their previous living environment will not be an easy task. Along with extensive building damage, many ports and airports in these cities will also be heavily damaged and most likely will not be operational immediately after the event. This puts more emphasis on the need for a resilient transportation network. Because we expect that the initial help for impacted coastal areas will come first from cities along I-5 and later from the rest of the state and entire Northwest region, we have identified I-5 as the most vital route for post-earthquake recovery.

Central Oregon U.S. 97 and Highways through the Cascades

In the event that Interstate 5 is not operational, particularly in areas without viable detours, U.S. 97 will be a critical facility for ongoing interstate commerce and for staging response and recovery efforts. Redmond Municipal Airport is a staging site for federal emergency response in Oregon. East-west corridors through the Cascades provide access to the more vulnerable parts of the state and are therefore a necessary part of the response and recovery system. Because there is far less likelihood of damage to facilities in these areas, they will be relied upon extensively after a Cascadia subduction zone event.

LOSS OF MOBILITY AFTER A MAJOR SEISMIC EVENT: LANDSLIDES & ROCKFALLS

Slope failures are as common to earthquakes as structural collapse, liquefaction, and ground deformation. Strong ground shaking from a Cascadia subduction zone event will trigger countless new slope failures and activate existing landslides. Reactivation of the known landslides alone will be catastrophic during the ensuing seismic emergency. Additional failure of weak slopes and embankments or reactivation of previously unknown landslides will further compound the catastrophe. Not only will the landslides occur during and soon after the main earthquake, strong aftershocks will also affect other landslides and slopes that will become more prone to failure in the ensuing months. Landslides will

continue to impede rescue and relief efforts long after the shaking has stopped. Figure 5.8 shows one of the common vulnerabilities of unstable slopes.

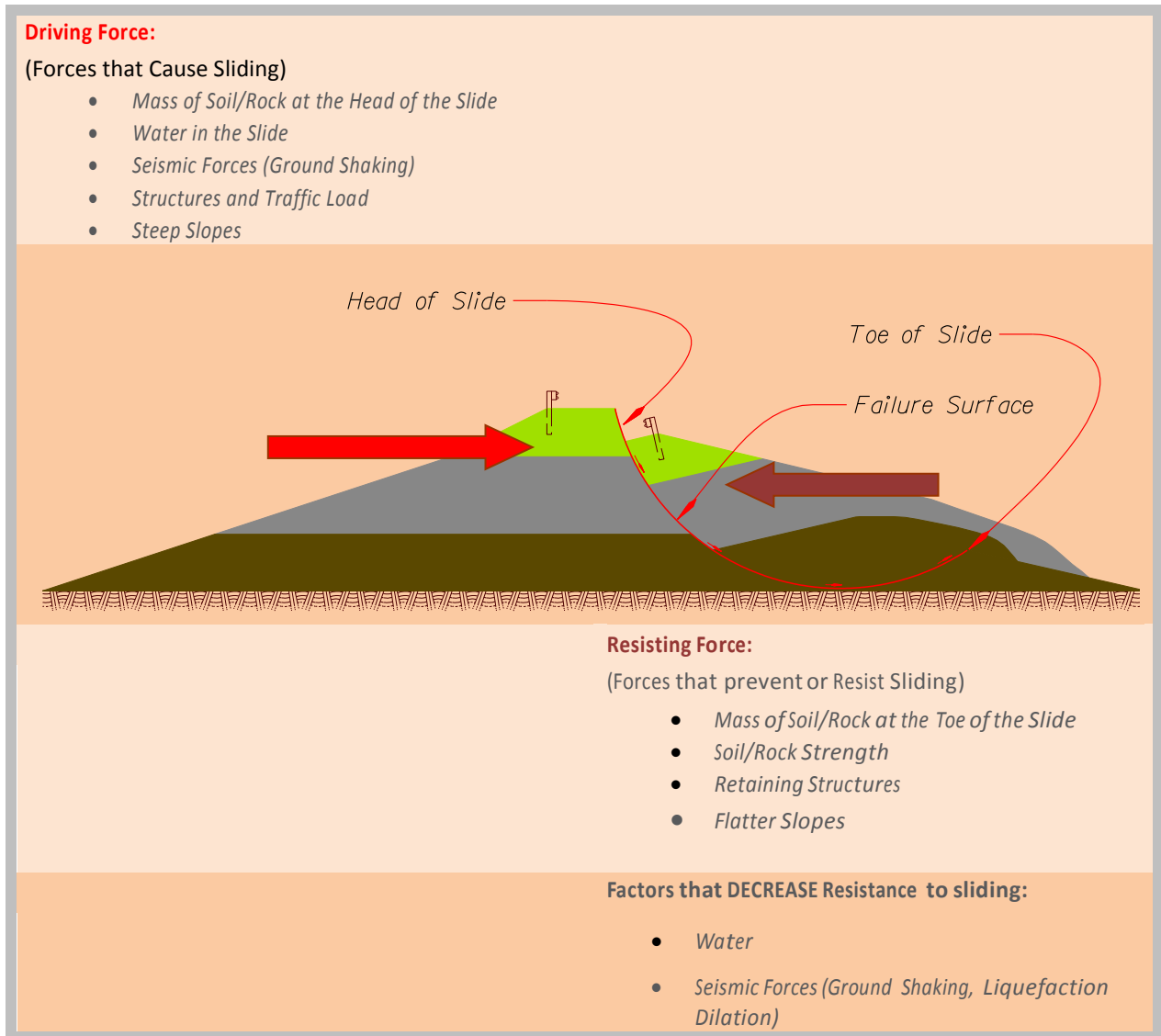

Figure 5. 8: Design Approach for Slide Mitigation (Source: ODOT – Geo-Environmental Section)

Landslides are one of the most significant secondary effects of earthquakes and, apart from the primary earthquake itself, one of the leading immediate causes of earthquake-related deaths worldwide. Currently, there are about 1,700 known landslides that directly affect the highway system between the Willamette Valley and the Oregon coast. Undoubtedly, western Oregon will be overwhelmed by the landslides that will accompany a Cascadia subduction zone earthquake. Landslides will affect all phases of the disaster, triggering a variety of consequences, including:

- Immediate injury or loss of life during the seismic event, as in the case of:
 - Motorists struck by rockfall or landslides/slide debris originating from slopes above the road.
 - Motorists striking materials in the roadway.
 - Motorists driving into collapsed roadways.
 - Motorists pushed off the roadway by landslides.
 - Vehicles or persons buried under slide debris.
- Immediate damage to the transportation infrastructure (resulting from numerous small to average-sized landslides and very large landslides), which becomes:
 - An impediment to tsunami evacuation.
 - An obstruction to rescue and evacuation efforts.
 - A hindrance both to recovery in the immediate aftermath and to long-term economic recovery.
- Long-term highway closures due to landslides.
- Ongoing landslides from weakened slopes.
- Disruption of utilities that share highway right-of-way.
- Long-term mitigation of very large landslides that will impede repairs to bridges and other facilities.
- Massive consumption and shortages of fuel and other material resources used in landslide repair work.

Steep slopes, weak soil and rock, heavy rainfall, and high groundwater are all conditions that can lead to slope failure and are widespread throughout the state, particularly in the western half. Almost every highway in western Oregon is affected in some way by landslides. Where the listed conditions exist, slopes are at a much higher risk of failure during an earthquake. The greatest hazards, however, are the existing known landslides and the existing slides that are yet to be discovered. Recent research by the U.S. Geological Survey (USGS) has shown that seismogenic landslides (that is, new slides initiated by earthquakes) tend to move a few inches to a few feet, while existing slides reactivated by earthquakes are more likely to move several yards. Highways traversing mountainous terrain will be the most disrupted; however, routes in low-lying areas, such as the Willamette Valley, will also be affected by liquefaction and lateral spreading, which can result in the failure of otherwise stable embankments and fills.

The following photos and diagrams describe some of the most common slope failure modes and one of the possible mitigation strategies for that type of failure.

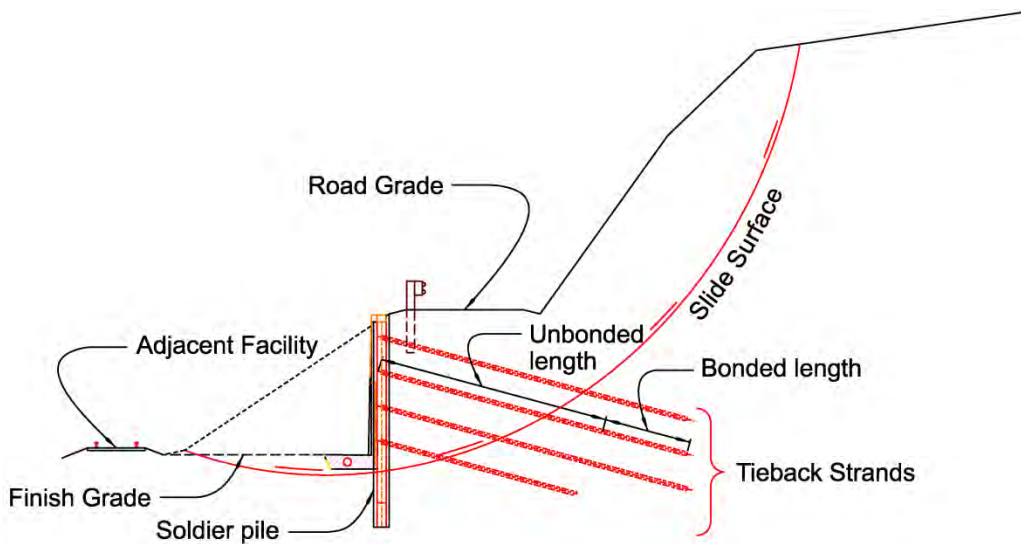

Figure 5.9: Structural mitigation of a landslide – Constructing a retaining wall (Source: ODOT – Geo-Environmental Section)

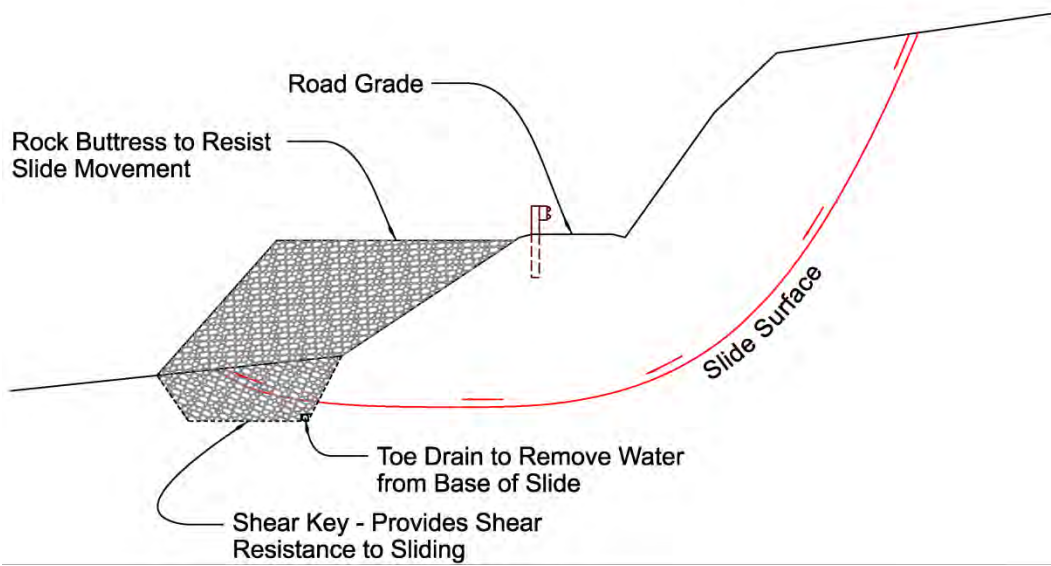

Figure 5.10: Stabilizing a landslide by constructing a shear key and buttress (Source: ODOT – Geo-Environmental Section)

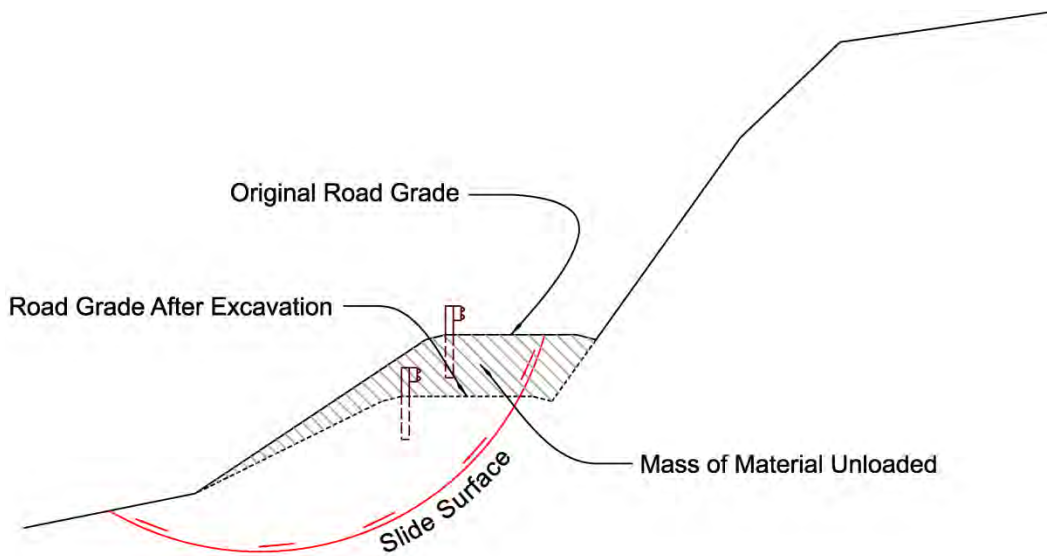

Figure 5.11: Stabilizing a landslide by the "unloading" method. (Source: ODOT – Geo-Environmental Section)

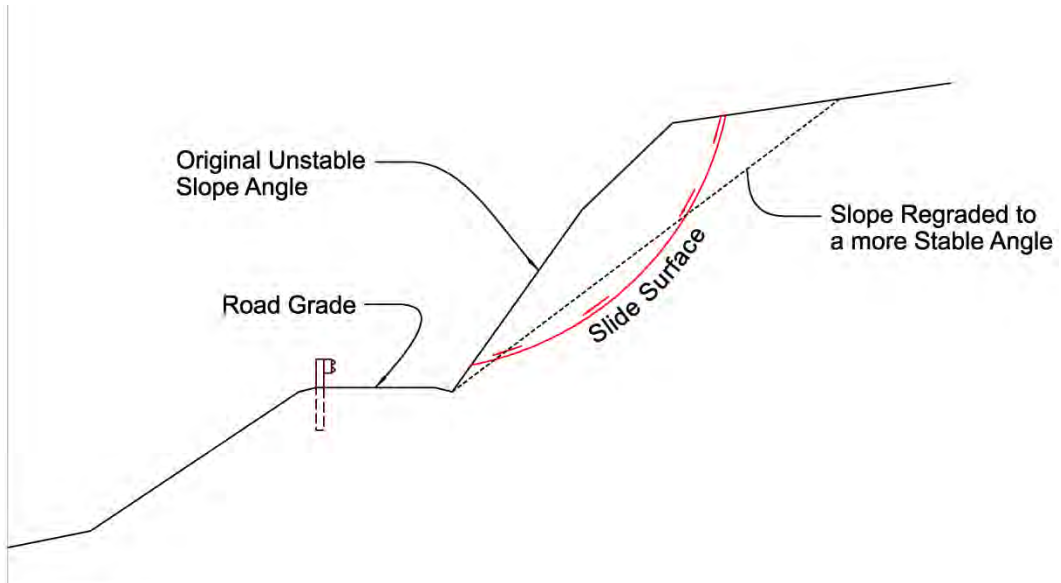

Figure 5.12: Flattening the slope decreases the “driving force” of an active slide (Source: ODOT – Geo-Environmental Section)

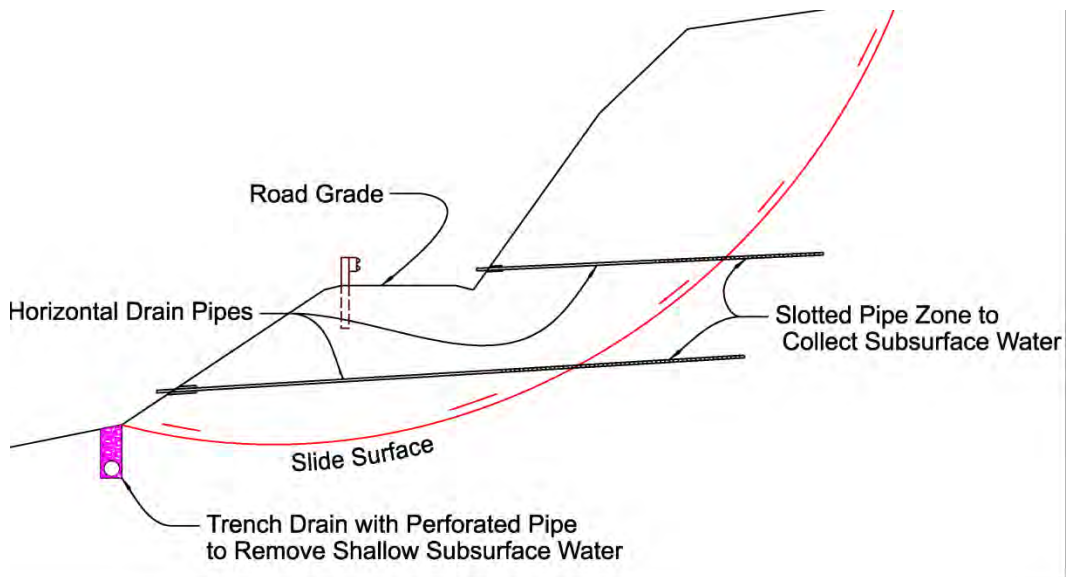

Figure 5.13: Drainage is one of the most cost-effective methods for landslide mitigation (Source: ODOT – Geo-Environmental Section)

Coastal Area: Impacts from Landslides and Rockfalls

As most residents of coastal Oregon know, there are numerous service disruptions on U.S. 101 every year from active landslides and rockfalls. It is a challenge for the agency just to keep this route functioning during normal winter weather. The results that strong ground shaking and the accompanying tsunami from a Cascadia subduction zone earthquake will have on this route are almost unimaginable, considering the large number of unstable slopes that will be affected by these forces.

Currently, 526 known unstable slopes directly affect U.S. 101. Many of these slides will fail catastrophically during the primary earthquake, while many others will fail during or soon after the tsunami. Slopes that do not immediately fail during the primary seismic event will be destabilized to varying degrees and may fail soon after, either during strong aftershocks or else at some time during the rescue and recovery efforts. Not only will coastal residents have to contend with the primary effects of the Cascadia subduction zone earthquake, but their evacuation, rescue, and recovery will be further hindered by landslides and rockfalls. Their escape from the tsunami may be blocked by failed slopes, and many could also become landslide victims.

East-West Corridor Impacts from Landslides and Rockfalls

If we take the hazard posed by landslides and rockfalls into account, the east-west routes connecting U.S. 101 to Interstate 5 are only marginally better than U.S. 101 itself. These routes traverse very steep terrain that is underlain by generally weak materials. In addition, the Oregon Coast Range experiences very high rainfall each year, which further serves to weaken slopes and embankments. A high number of landslides occur in this area on an annual basis, and a very high number should be expected during a Cascadia subduction zone event, solely on the basis of the geologic conditions.

What makes these routes particularly vulnerable is the existence of very large landslides along them. These existing slides are expected to have the highest amounts of displacement during an earthquake. Whole mountainsides can move tens of yards vertically and horizontally, taking the entire roadway with them. These landslides have the capacity to close roads for several weeks while efforts are made to reconstruct roadways or build detours around the slides. Recent LiDAR technology, where available, has led to the discovery of many of these large, sometimes ancient, landslides. In some cases, the slides were previously known, as they have had some effect on the highway in the past. In other cases, highways traverse enormous landslide features that were not known to exist and have been inactive since their initial failure. It has been theorized that many of the known large, ancient landslides in the Oregon Coast Range and the Columbia River Gorge are the result of past Cascadia subduction zone events.

Interstate 5 and Mid-Willamette Valley: Impacts from Landslides and Rockfalls

Interstate 5 and other highways in the Willamette Valley are not without their own landslide and rockfall vulnerabilities. Many fills and embankments were either constructed of or on liquefiable soils in areas with high groundwater, making them particularly susceptible to earthquakes. Interstate 5 also traverses

mountainous terrain in the southern part of the state, and unfavorable geology contributes to ongoing slope instability along I-5 in the Portland area.

In all, there are 49 known landslide and rockfall areas along I-5. Other unstable areas are suspected. In the event of a Cascadia subduction zone earthquake, therefore, the most important route in the state will not be without problems. Many of the slides through the Willamette Valley are minor and can be readily mitigated. Most of the slides in the Portland area have been treated, but some could result in lengthy repairs and service disruption. For the Portland area, adequate detours exist in areas that are not as vulnerable to landslides, but delays will occur. The greatest concern for this route is the mountainous areas of southern Oregon. Unfavorable geology—in terms of geologic structure, materials, and groundwater—has formed some very large, complex landslides in this area. These slides have the capacity to cut this route off on the southern end for many weeks while repairs take place or detours are constructed.

Rail Transportation

Rail lines are generally privately owned businesses, not public entities. Detailed vulnerability assessments of this part of Oregon’s infrastructure have not been conducted, although generalizations can be drawn about its possible performance based on experience in other regions where major earthquakes and tsunamis have occurred. Funding for such detailed studies may be problematic due to the private ownership status of railroads.

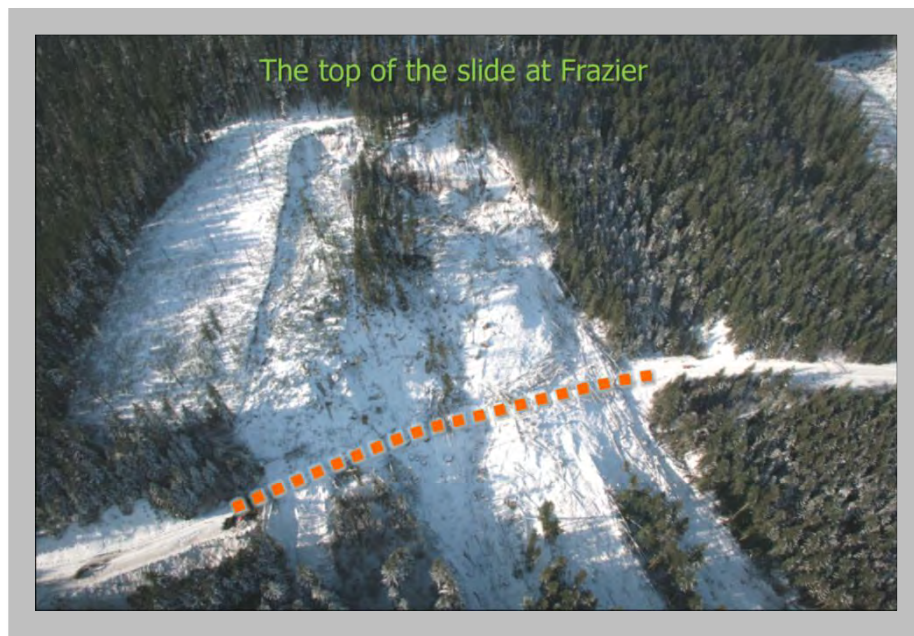

Figure 5.14: Landslide damage on the UPRR between Chemult and Eugene
(Source: ODOT – Rail Division)

Trunk Lines

- California State Line to Klamath Falls
 - UPRR: Several miles of dredged fill, one highway overpass, two tunnels in California
 - BNSF: Two major bridges, one highway overpass
- Klamath Falls to Chemult
 - UPRR/BNSF: One major bridge, five highway overpasses
- Chemult to Redmond
 - BNSF: Two major bridges, five highway overpasses
- Redmond to OT Junction (BNSF); OT Junction to Troutdale (UPRR)
 - Seven major bridges, three tunnels, twenty-three highway overpasses
- Chemult to Eugene
 - UPRR: Fourteen major bridges, twenty-one tunnels, seven highway overpasses, six snow and rock sheds
 - Major historical landslide
- Eugene to Portland
 - UPRR: Fifteen major bridges, thirty-two highway overpasses
- Portland Terminal Area (Troutdale to Portland (UPRR); Vancouver, WA, to Portland (BNSF))
 - Four major bridges, forty-two highway overpasses

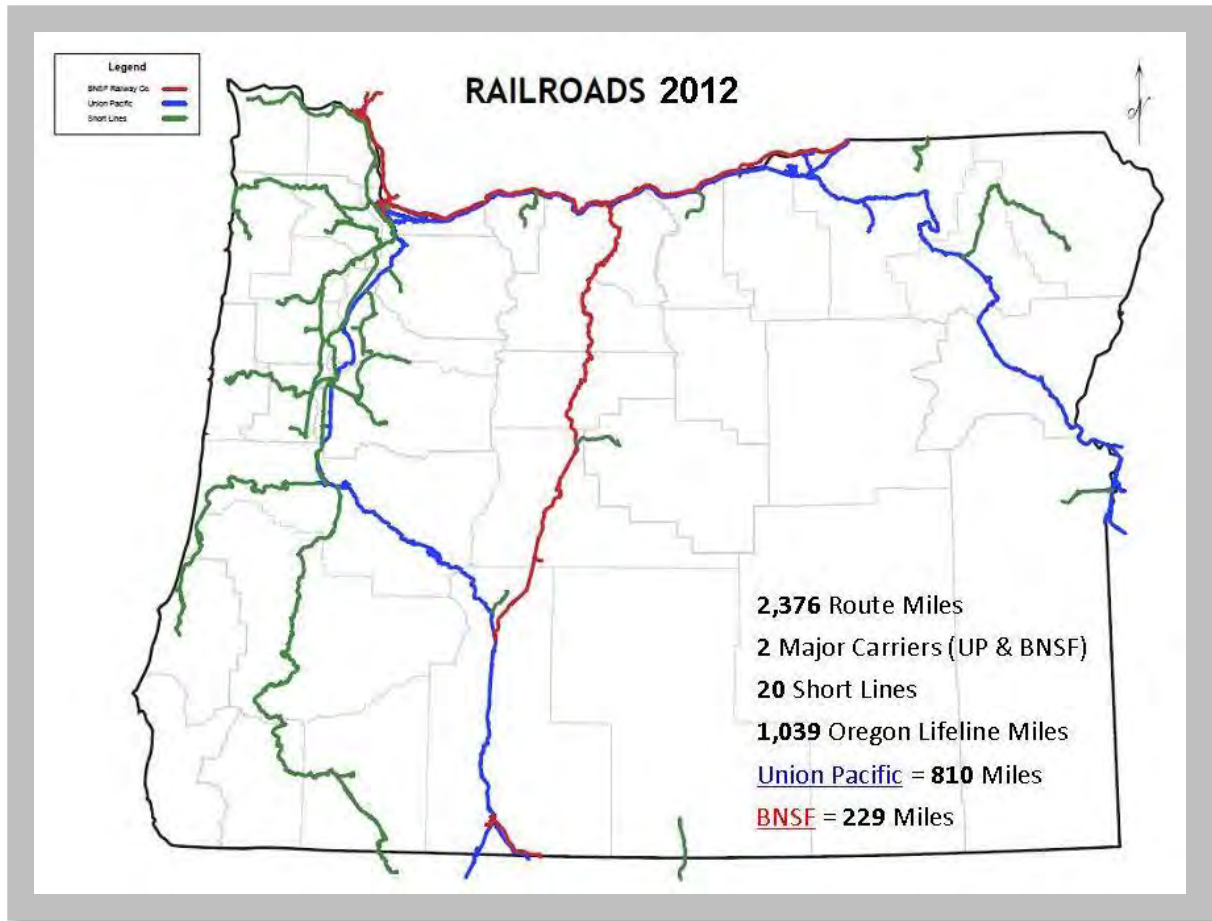

Figure 5.15: Railroad Corridors (Source: ODOT – Rail Division)

Detours for Trunk Lines

- Siskiyou Line (California to Eugene): Steep grades, twenty-four major bridges, eleven tunnels, twenty highway overpasses
- Oregon Electric Line (Eugene to Tigard): Fifteen major bridges, seven highway overpasses
- West Side District (Albany to Tigard): Fifteen major bridges, two highway overpasses
- Tigard to Willsburg Junction and connection with UPRR Trunkline: Three major bridges, three highway overpasses

Coastal Branch Lines

- Coos Bay Rail Link: Forty-nine major bridges, eight highway overpasses, nine tunnels
- Astoria District: One tunnel, six highway overpasses
- Albany to Toledo: Forty major bridges, one tunnel, three highway overpasses

Air Transportation

The state of Oregon has an extensive aviation system that provides valuable transportation options for the public, ranging from small airports in remote regions of the state to large commercial service airports. Ninety-seven public-use airports provide support to the economic health and vitality of Oregon and contribute to the quality of life for its citizens and visitors.

- Fifty-seven public-use airports are partially supported by FAA and included in the National Plan of Integrated Airport System (NPIAS).
- Sixteen public-use airports are either owned by other municipalities or are privately owned.
- Over 400 private airports and landing strips are located within Oregon.

The 2007 Oregon Aviation Plan established five categories of airports, based on the definitions outlined within the National Plan of Integrated Airports System (NPIAS), the design criteria outlined by the Airport Reference Code (ARC), and the facilities inventory.

CATEGORY I: COMMERCIAL SERVICE AIRPORTS

These airports support some level of scheduled commercial airline service in addition to a full range of general aviation aircraft. This includes both domestic and international destinations.

CATEGORY II: URBAN GENERAL AVIATION AIRPORTS

These airports support all general aviation aircraft and accommodate corporate aviation activity including business jets, helicopters, and other general aviation activity. The primary users are business related and service a large geographic region, or they experience high levels of general aviation activity.

CATEGORY III: REGIONAL GENERAL AVIATION AIRPORTS

These airports support most twin and single engine aircraft, may accommodate occasional business jets, and support regional transportation needs.

CATEGORY IV: LOCAL GENERAL AVIATION AIRPORTS

These airports primarily support single engine, general aviation aircraft, but are capable of accommodating smaller twin-engine general aviation aircraft. They also support local air transportation needs and special use aviation activities.

CATEGORY V: REMOTE ACCESS AND EMERGENCY SERVICE AIRPORTS

These airports primarily support single-engine, general aviation aircraft, special use aviation activities, and access to remote areas; or they provide emergency service access.

The following list identifies airports within each category that have the potential to maintain or quickly restore operational functions after a major earthquake. The Transportation Task Group arranged these 29 airports into a tier system to indicate the priorities for making future investments. Tier 1 (T1) is comprised of the essential airports that will allow access to major population centers and areas

considered vital for both rescue operations and economic restoration. Tier 2 (T2) is a larger network of airports that provide access to most rural areas and will be needed to restore major commercial operations. Tier 3 (T3) airports will provide economic and commercial restoration to the entire region after a Cascadia subduction zone event.

Category I	Category II	Category III	Category IV	Category V
*Redmond (T1)	Scappoose (T2)	Tillamook (T2)	Mulino State (T3)	Independence State (T3)
PDX (T1)	Troutdale (T3)	Roseburg (T1)	Albany (T3)	Siletz Bay State (T2)
Salem (T1)	Hillsboro (T2)	Bandon State (T2)	Lebanon (T3)	Cape Blanco State (T2)
Eugene (T1)	Portland Heliport (T3)	Grants Pass (T3)	Florence (T3)	
Rogue Valley Medford (T1)	Aurora State (T3)		Creswell (T3)	
Klamath Falls (T1)	McMinnville (T3)		Cottage Grove State (T3)	
	Newport (T2)		Myrtle Creek (T3)	
	Corvallis (T3)		Brookings (T2)	

*Primary emergency response airport for FEMA Region X: Redmond municipal airport, centrally located in central Oregon, is ideally situated to be the primary FEMA emergency response airport.

Figure 5.16: Oregon Airports (Source: Oregon Department of Aviation)

The Portland International Airport (PDX) is one of Oregon’s vital transportation network links. As the state’s major airport, PDX will play a key role in re-establishing our economy by facilitating the movement of people, goods, and services after a major statewide emergency event. Other airports in Oregon will also play a vital role during the post-disaster emergency response and initial recovery phase. During the emergency response, for example, displaced residents, injured people, and the elderly may need to be evacuated by means of airports; and airports will also provide a staging area for needed supplies (such as water, food, medical supplies, and materials for temporary housing). Until highway and rail transportation can be fully restored, air transportation, along with ships off the coast, will be the lifelines for Oregon’s citizens.



Figure 5.17: An aerial view of Port of Portland (Source: Port of Portland)

As described previously in this chapter, after a Cascadia subduction zone event, 29 airports have the potential for minimal damage, and operational service could be restored within a short timeframe. However, without a complete vulnerability assessment of these 29 airports, we cannot be certain which airports would be operational after an earthquake of magnitude 9.0. Based on Oregon Department of Geology and Mineral Industries (DOGAMI) tsunami inundation maps, we can predict with reasonable accuracy which airports would survive a tsunami. After studying these maps, we concluded that 8 out of 15 coastal airports will not survive due to the inundation of ocean water and debris. In the absence of a complete vulnerability assessment, our assumption is that seven of the coastal airports may survive a tsunami, but we do not know if they will survive an earthquake. Those seven airports are Tillamook, Siletz Bay State, Newport, Florence, Bandon State, Cape Blanco State, and Brookings.

Note: We did not consider the eastern airports in this particular scenario, as those airports are expected to sustain little to no damage during a subduction zone earthquake.

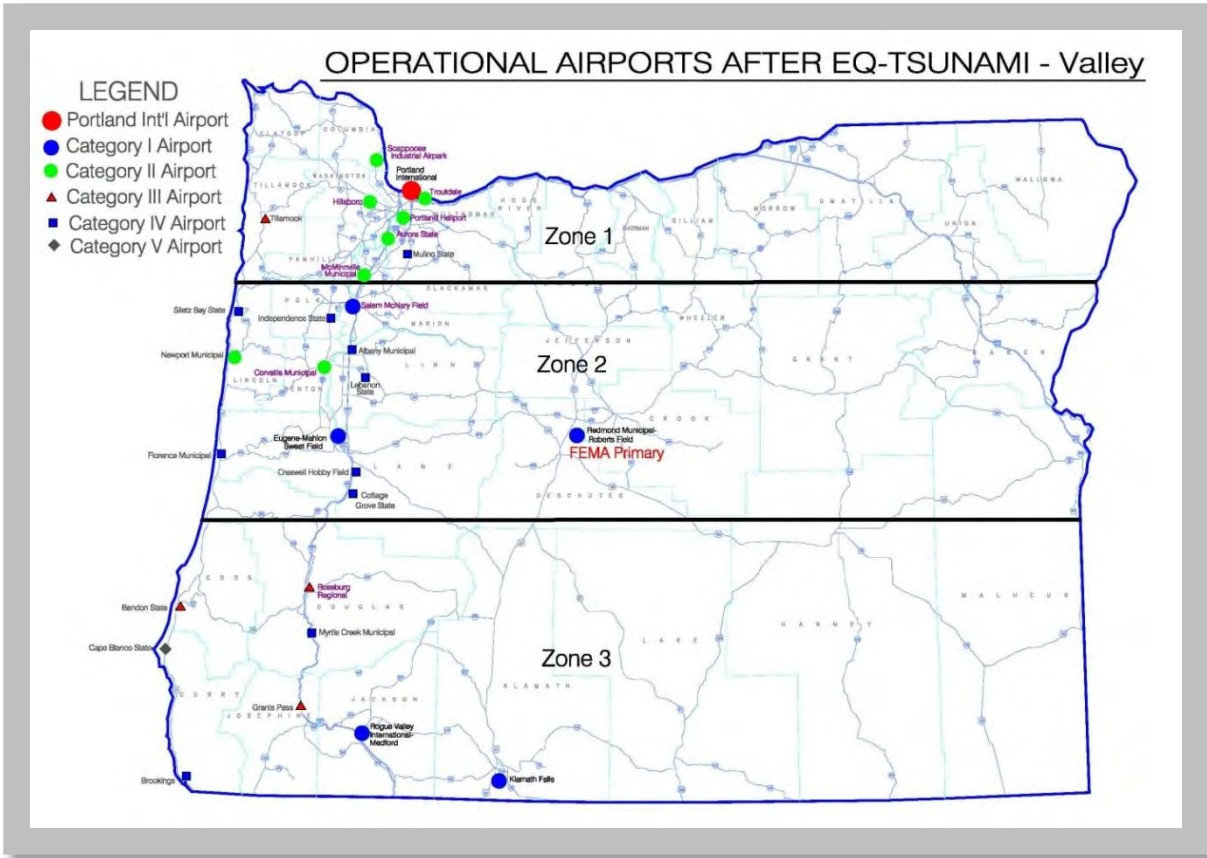

Figure 5.18: Emergency service zones served by air transportation (Source: Oregon Department of Aviation)

Columbia and Willamette Navigation Channels

The Columbia and Willamette Rivers are important transportation corridors for the states of Oregon and Washington. The lower Columbia (Pacific Ocean to Portland) and lower Willamette Rivers are deep draft channels and are critical for connecting transpacific trade to the region and the state. The mid-Columbia and Snake Rivers (Portland to Lewiston, Idaho) are shallow draft, inland waterways along which significant cargo can be moved from the east to the Portland region. Multiple dams and locks are necessary for the operation of this river route. Redundancy does not exist for these dams and locks—a cause for concern because the river channels may be obstructed when bridges collapse during a significant earthquake. A Cascadian event could significantly impact the river system and shipping channels. The jetty at the mouth of the Columbia is susceptible to severe damage from significant seismic event and tsunami. Failure of the jetties would significantly impact the channel. The channel depth at the mouth would likely be severely constrained due to sands migrating in from the beaches adjacent to the jetties. Additionally, the navigability of the Columbia River Bar would be difficult and unsafe for many vessels.

Critical factors affecting marine terminal viability include the condition of navigation channels immediately following a seismic event and how quickly and successfully resources can be deployed to

assess and clear navigation channels of silt and structural obstructions. Shipping channels would be constrained as a result of lateral spreading of the channel banks, which will shift sediment into the channel. In addition, the pile dike systems along the river, which are intended to prevent sediments from migrating into the channel, are susceptible to failure during a major seismic event. Significant failures could dramatically impact the hydrology of the Columbia River. Depending on the seismic impact, deep-draft ships that are in transit in the waterway could become stuck due to a sudden shifting of material. This shift would cause the navigation channel to become shallower, cutting off navigation by other vessels and endangering the ships themselves. Additionally, structures that collapse into the navigation channel would need to be removed to allow ships to pass safely. Initially, shallow-draft barges may be the only viable option to move material and goods to and from marine terminals; or ship calls will be diverted to other, unaffected ports and regions. Marine terminals near the coast will also be exposed to the effects of tsunami waves, which could severely impact dock structures and support facilities. Timely restoration of the channel to resume current shipping operations is dependent upon the availability of dredges and federal funding authorizations.

In preparation for a Cascadia subduction zone event, dredging capabilities and resources should be identified and plans developed to assess and acquire services to ensure that the Columbia River navigation channel is cleared of sediment and returned to a minimal, and ultimately full, level of service. Pre-event analysis should be considered to identify which areas are likely to be most vulnerable to large-volume sediment movement during a Cascadia subduction zone event. Such analysis will help facilitate planning and ensure that resources will be dispatched to the areas of highest vulnerability. Following a Cascadia subduction zone event, hydrographic resources will need to be deployed to assess the condition of the navigation channel along its entire length and identify segments that need urgent dredging to re-establish river navigation of deep-draft ships. Disposal sites should be identified at strategic locations to align with dredging capabilities.

An assessment of contracting resources capable of accomplishing dredging in the region should be developed and agreements should be considered to establish who will have first rights to those construction resources. Such an assessment should also include the creation of an inventory of dredging resources and capabilities. It is expected that USACE will manage dredging activities and direct resources to areas of highest priority and need. Advance coordination with environmental permitting and regulatory agencies should be considered to ensure that dredging and placement do not violate statutory requirements.

RIVER PORTS

The vulnerability of marine terminals and navigable waterways to the effects of a major seismic event is highly variable and depends on many factors. There are several major elements associated with a marine terminal that have different—but interdependent—risks.

Some of the major elements of marine terminals that are critical to maintaining functional operation include dock structures; berths; dock-side equipment associated with material loading and unloading;

intermodal systems serving the marine terminals, including rail, roads, and bridges; the land on which the terminals were developed and its associated geotechnical characteristics; levee structures that protect marine commercial districts and, in some cases, aviation facilities; and river channels that provide passage for deep-draft vessels. These elements should be analyzed both individually and as parts of an overall system that serves marine cargo operations.

Dock structures are comprised of a wide array of systems of differing ages and with varying abilities to withstand seismic impacts. Their capacity to survive a great earthquake is dependent not only on the materials and methods used to construct them, but on their age, their condition, and the stability of the land beneath and surrounding them. For example, many marine facilities were constructed on fill material placed over historic wetlands. Such material is generally fine and granular in nature and susceptible to liquefaction if provisions are not made to resist such forces or relieve the pore pressure resulting from a high water table and seismic shaking. A structurally sound dock structure must also be supported by stable adjoining land. As has been noted in seismic events worldwide, lateral spreading (caused by seismically induced liquefaction) of the land adjacent to dock structures has contributed significantly to their damage profile. Stabilizing the adjoining land to resist lateral spreading minimizes the damage to the dock, reduces the sloughing of soil into the berth prism, and allows for a faster return to service of the dock and loading equipment.

The integrity of intermodal connections to other transportation systems, including rail, roads, and bridges, is critical to the functionality and viability of marine ports. The integrity and operability of the regional power grid and on-site generation capabilities are also critical to marine terminal operations. These elements are addressed in other sections of this report, but are noted here to emphasize the overall integration of the system that serves marine terminals.

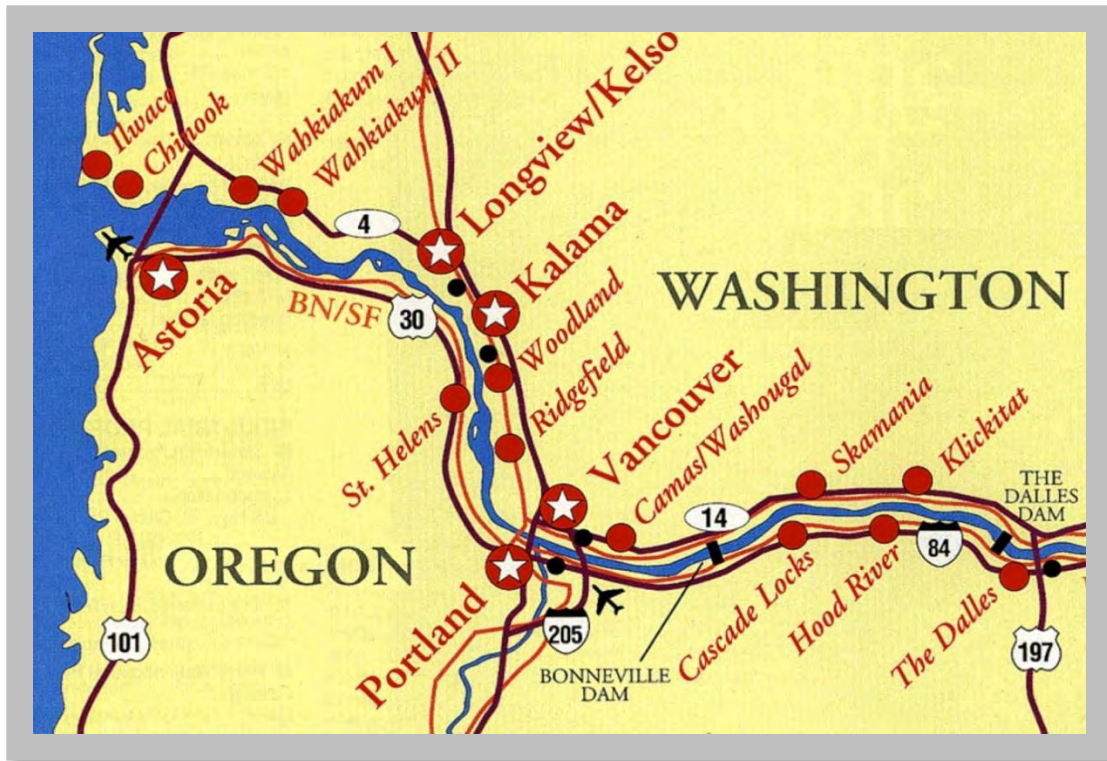

Figure 5.19: Columbia River Channel and port (Source: Port of Portland)

COASTAL INLET JETTIES

The tsunami generated by a Cascadia earthquake measuring magnitude 8–9 could range in height from 5 to 30 feet along the present shore face. In addition, co-seismic subsidence (caused by the release of built-up strain in the tectonic plates) may induce immediate lowering of the coastal margin by 2 to 8 feet (Atwater and Hemphill-Haley, 1997). In other words, the elevation of the shoreline is expected to drop during the earthquake and just before the first tsunami waves arrive.

The effect of a tsunami of this size on the coastal inlet jetties of the Pacific Northwest would be significant and transient: the overland flow of the tsunami is likely to destabilize the roots of all the jetties by eroding the morphology along the jetty roots, which may be flanked by the overland flow. Immediate repairs would be needed to re-secure the jetty roots. The seaward ends of the jetties could be affected by significant, severe scour due to the volume of water transported into and out of the inlet in response to the tsunami's passage and residual circulation. A significant volume of sediment may be mobilized and deposited within the inlet.

Violent shaking during the earthquake is also likely to destabilize many jetty areas having a side slope steeper than 1V:2H. Liquefaction of the jetty foundation may occur and initiate jetty settlement and toe failure. If vertical co-subsidence occurs with the Cascadia subduction zone earthquake, the long-term effects on the jetties of the lowering of the existing land margin by two to eight feet may be more profound than the earthquake and tsunami. Jetty freeboard could be significantly reduced and depth-

limited wave height would be significantly increased. This effect would significantly increase the rate of jetty degradation and expose the landward areas of each jetty to increased wave loading and overtopping. Jetties that were in a good state of repair (or recently rehabbed) would be more resistant to earthquake related damages as opposed to jetties that were in a condition of deferred repair.

Following such an event, a triage approach would be implemented at USACE coastal navigation projects to assess the condition of jetties, inlets, and navigation channels. High tonnage, deep-draft projects would be given higher priority than shallow-draft, low tonnage projects. Estimates for channel shoaling (required dredging) and jetty damage (required repairs) would be developed, and, if available, resources would be mobilized to re-establish a minimum level of functionality for the navigation infrastructure.

Immediate response for high priority coastal navigation projects (within our ability to respond) would be to secure the jetty roots, if these areas were breached. A breached jetty root can lead to reformation of the inlet's channel and loss of navigation. Rapid placement of stone/rip-rap along the breached jetty (at the root) would be executed, sufficient to stop tidal flow through the breached area. If required, the navigation channel may be dredged in affected areas to make it navigable again. In the long term, the affected jetties may require expedited maintenance to address damage.

COASTAL PORTS

Coastal ports in Oregon are essential for the economies of the coastal communities and will be critical for disaster response and subsequent economic recovery. Unfortunately, they are also at risk for catastrophic damage in the event of a Cascadia subduction zone earthquake and subsequent tsunami. Elements of port infrastructure that should be considered priorities include jetty/breakwater structures protecting entrances, navigation channels, docks and piers, slips, pier-side equipment, structures, and transportation linkage with rail, air, and highway.

The vulnerability of jetties and breakwaters to the potential actions of an earthquake and tsunami should be analyzed further, along with the potential effects that vertical shifting, silting, debris, and obstruction could have on channel depths. Necessary reinforcement of jetties and breakwaters is essential to maintain port entrances, as is continuing maintenance-dredging of channels.

Dock and pier structures will be exposed to severe damage due to surging currents, debris impacts, possible tsunami inundation, and liquefaction (where piers are built on fill material). Reinforcement of pier and shore-side bulkheads, which could limit damage and allow for faster recovery of port operations, should be considered a priority.

Due to their locations, the intermodal connections of most coastal ports are critical for port functions. It is necessary that Oregon prepare for and mitigate against damage to rail links, bridges, highways, adjacent airports, power supplies, and communications. Critical equipment and structures will also need to be identified and reinforced for use as maritime disaster response command centers and subsequent recovery and rebuilding efforts.

Waterborne rescue and recovery operations may have to be provided through coastal ports; this may be the only viable option for many of Oregon’s coastal communities if highway corridors fail. So even though the infrastructure of many coastal ports may be devastated, their very locations will have to serve as landing sites for waterborne support (from barge, amphibious, and shipping operations). Temporary facilities provided by barges and cranes may be used to restore makeshift docks quickly for rescue and recovery operations, as was experienced in Haiti. Functionality for commerce would take longer.

Transportation resilience planning and preparation for coastal ports is critical to minimize post-event casualties, speed rescue, and allow for the economic recovery of the Oregon coast. In addition to supporting rescue and recovery operations after the earthquake and tsunami, coastal ports should serve as recovery hubs from which transportation reconstruction can reach out along the coast while transportation corridors between coastal and inland areas are being restored.

Public Transit Services

Five public transit regions correspond to ODOT highway regions. Within these regions are approximately 113 significant public transit agencies and several dozen more subcontractors who provide various forms of publicly-funded transportation service, including demand response, intercity service, and alternative transportation options. The role played by public transit service has proven to be critical during the initial response to and recovery from other major natural disasters, earthquakes included. It should therefore be considered a major component of our disaster preparedness plan.

Oregon has a full spectrum of transit providers, ranging in size from very large to very small, and extending geographically from large urban centers, such as Portland, to small coastal communities and remote rural eastern Oregon towns. Transit services in some form are provided in all 35 Oregon counties and to nine federally-recognized Indian tribal communities. About 128.5 million one-way rides are provided for Oregon residents and visitors each year. Public transit buses and smaller vehicles log 52.1 million miles of travel each year, providing over three million total annual hours of public transit operating service statewide.

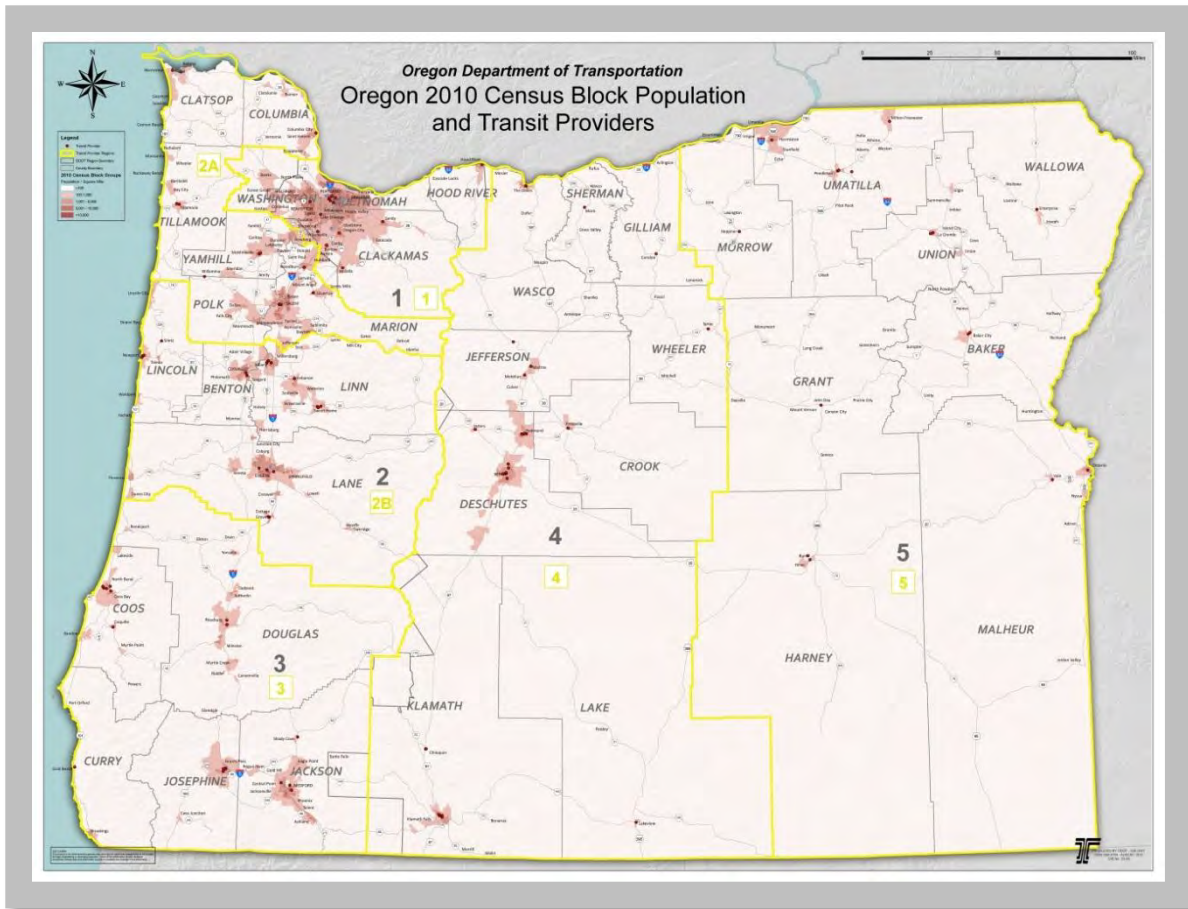

Figure 5.20: Oregon 2010 Census Block Population and Transit Providers (Source: ODOT Public Transit & GIS Technical Services)

Tri-Met, Lane Transit District (LTD), and Salem-Keizer Transit are the three largest transit agencies in the state. These are large, sophisticated agencies with their own extensive emergency management planning, incident command and response systems, and business recovery/resilience plans and procedures in place, all of which have been developed cooperatively with other public agencies and first responders in their respective areas. Additional systems, designated as small urban systems by the Federal Transit Administration and including the Rogue Valley area, Bend-Redmond, Corvallis, Albany, Grants Pass, and the Tri-Cities area, also have varying levels of detailed local emergency planning and recovery plans in place.

The remaining public transit agencies are rural or small town systems with often minimal resources in place to conduct significant planning and very few financial resources to invest in resilience following a catastrophic natural disaster. Excluding Tri-Met, LTD, and Salem-Keizer, the remaining 110 transit agencies share over \$107 million in federal and state grants awarded through ODOT, with approximately two-thirds of available funding going towards simply maintaining daily or weekly operations and one-third toward capital expenditures (primarily replacement buses).

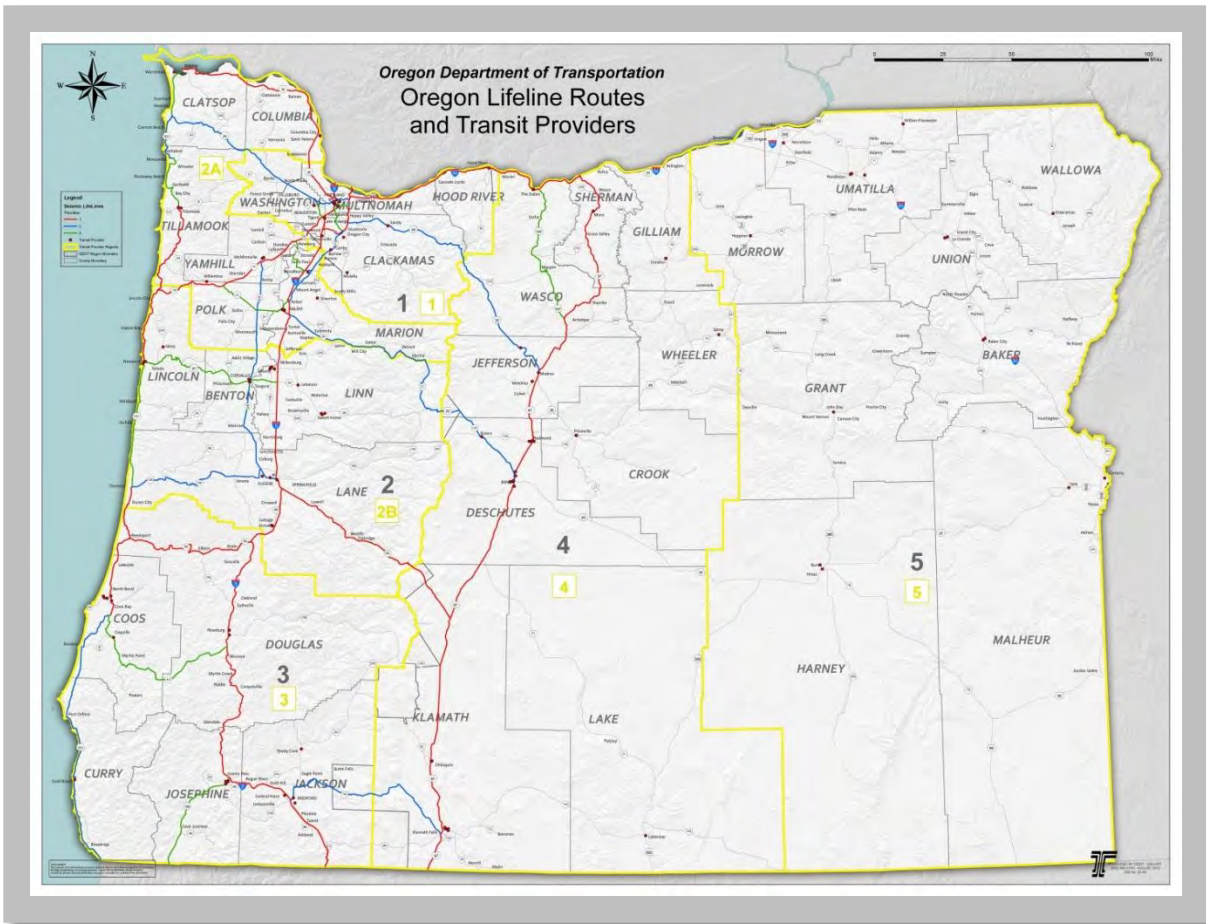

Figure 5.21: Oregon Transit Providers (Source: ODOT Public Transit & GIS Technical Services)

Transit agencies could play an important role in helping Oregon recover from a major natural disaster. Oregon transit agencies are positioned to serve the major state population centers. Public transit buses, in conjunction with school district buses, may be able to assist with emergency evacuation—either before the event, in the case of predictable natural disasters, or after the event, in situations such as a great earthquake, in which people must be transported out of an impacted area. Public transit buses could also be used to transport emergency workers or supplies to and from affected areas; to transport workers to recovery-related jobs when private automobile traffic is constrained due to road conditions and fuel supplies; and to transport seniors, persons with disabilities, and injured citizens to and from medical treatment appointments or to places where they can shop for food and other necessities.

Combining buses purchased through ODOT with those buses purchased directly by the larger urban agencies, over 1,500 buses and transit vehicles are currently deployed across the state; adding district school bus fleets would increase that number by several thousand. Most transit buses are equipped with wheelchair lifts, which, during emergency relief efforts, could also be useful in transporting and deploying both emergency personnel and their accompanying supplies and gear.

Transit providers are generally located on Oregon's lifeline routes. While this means that transit agencies are well placed to be able to assist with response and recovery activities, it also means that the transit system is dependent on local roads and highways and cannot respond if roads are impassable. Once roadways are cleared for minimum critical vehicle travel, public transit vehicles may be deployed by emergency command for the purposes of evacuating residents and transporting relief personnel.

Depending on the scale and location of the Cascadia subduction zone event and the resulting direction of tsunami wave generation, some coastal transit facilities, such as Columbia County CC-Rider, Sunset Empire Transit District, Tillamook County Transportation District, Lincoln County Transportation District, and Coos Bay Area Transit, may be inundated by the tsunami and consequently unable to respond. The ability of non-coastal transit agencies to assist coastal transit agencies is dependent on whether highways connecting the Willamette Valley to the coast remain passable. In particular, landslide risks may impair transit's ability to respond. Region 2 has the highest landslide risk (that is, this region has more historical landslide sites).

The importance of the human factor in recovery activities following a major emergency is often underrated. Public transit is dependent on drivers, mechanics, dispatchers, and supervisors all working together to maintain and support daily operations. Some transit drivers are volunteers. Personnel must first be able to get to central agency locations, where both vehicle and communication assets must be operable, in order to provide public services. This also means there must be a way for these men and women to know that their families and loved ones are safe while they return to work. Although some emergency response personnel, such as firefighters and National Guard troops, do have commercial driver's licenses, they are generally not accustomed to driving buses, nor are they necessarily familiar with local streets and routes. Most importantly, drivers for demand-response transit services know where the vulnerable populations in their communities reside, which can be critical to saving lives in the hours and days immediately following a catastrophic event.

In summary, for public transit service restoration, short-term resilience is largely dependent on at least three primary factors:

- The condition and accessibility of the repaired roadway and (in coastal and valley areas) the bridge system.
- The ability of transit agency drivers, mechanics, dispatchers, and other key staff to respond following a catastrophic event.
- The status and availability of fuel supplies.

Longer-term resilience will also depend largely on the availability and prioritization of expenditure of public relief funds in the impacted areas. Certainly, without federal and state financial assistance, few of our local transit agencies would have the internal financial resources to finance major infrastructure rebuilds. These factors are difficult to forecast accurately given both the predicated severity of the

natural event upon which the resilience assessment is based and the competing demands for public funds which would follow.

Local Roads and Streets

For many communities, the local road and street system provides the only access to many critical facilities following a disaster event. These facilities include hospitals, fire stations, and locations where temporary food and housing are to be provided. Local roads and streets can also provide detours around failed state highway system facilities. One of the observations made after the recent subduction zone earthquake in Chile was that the local road and bridge system tended to survive better than the state system. This was because the local roads tended to be straighter and wider, which resulted in larger roadway cuts and fills. As a result, many of the local roads and streets were used as detours for damaged state highway roadways and bridges. On the other hand, because many local roads and streets are narrow, with very sharp curves, they cannot safely accommodate a high volume of traffic.

In addition to local roads and streets, Oregon has thousands of miles of forest roads, and it may be possible to use these for low-volume, temporary local detours in the event of a major disaster. Many of these forest roads are privately owned and will also be subject to significant damage in a Cascadia subduction zone earthquake. Nonetheless, such local-road detours will likely serve emergency responders, repair crews, and vehicles transporting food and other critical supplies, and will therefore play an important role as recovery efforts progress and a minimum level of service is restored.

Resilience Gap Analysis Summary

Where possible, the gap analysis is based on an engineering evaluation of vulnerability and seismic resistance. Where engineering or other technical studies have not been completed, the analysis is subjective, based on generalizations of leading indicators, such as year of construction, seismic code at the time of design and construction, assessment of current conditions, and comparison with performance of similar facilities in subduction zone earthquakes in other areas of the world. Where detailed studies have not been completed, recommendations are included for further studies to fill the gap.

The current state of Oregon's transportation systems and the anticipated time to restore service after a Cascadia subduction zone event is represented in the figure shown below. The table also provides targets for the relative time needed to restore service if the system were strengthened or retrofitted.

Oregon Transportation Resiliency Status

***Key to the Table**

<i>TARGETS TO ACHIEVE DIFFERENT LEVELS OF RECOVERY:</i>										
Minimal: (A minimum level of service is restored, primarily for the use of emergency responders, repair crews, and vehicles transporting food and other critical supplies.)										R
Functional: (Although service is not yet restored to full capacity, it is sufficient to get the economy moving again— e.g. some truck/freight traffic can be accommodated. There may be fewer lanes in use, some weight restrictions, and lower speed limits.)										Y
Operational: (Restoration is up to 90% of capacity: A full level of service has been restored and is sufficient to allow people to commute to school and to work.)										G
ESTIMATED TIME FOR RECOVERY TO 60% OPERATIONAL GIVEN CURRENT CONDITIONS:										S
ESTIMATED TIME FOR RECOVERY TO 90% OPERATIONAL GIVEN CURRENT CONDITIONS:										X
Comparison of Target States and Estimated Time for Recovery										
<i>Infrastructure Facilities</i>	<i>Event Occurs</i>	<i>0 – 24 hours</i>	<i>1 – 3 days</i>	<i>3 – 7 days</i>	<i>1 – 4 weeks</i>	<i>1 – 3 months</i>	<i>3 – 6 months</i>	<i>6 – 12 months</i>	<i>1 – 3 years</i>	<i>3+ years</i>
Central Oregon Zone										
► OREGON STATE HIGHWAY SYSTEM										
State Highway System - Tier 1 SLR ¹⁾										
Roadways			R	Y	G			S	X	
Bridges			R	Y	G/S		X			
Landslides			R	Y	G			S	X	
State Highway System - Tier 2 SLR										
Roadways			R		Y	G			S	X
Bridges			R		Y	G/S		X		
Landslides			R		Y	G		S	X	
State Highway System - Tier 3 SLR										
Roadways				R		Y	G		S	X
Bridges				R		Y	G/S		X	
Landslides				R		Y	G		S	X
State Highway System - Other Routes										
Roadways					R		Y	G	S	X
Bridges					R		Y	G	S	X
Landslides					R		Y	G	S	X
► AIRPORTS & AIR TRANSPORTATION										
Tier I - Oregon Airports System										
Redmond Municipal Roberts Field Airport - FEMA		R	S		Y	G	X			
Klamath Falls Airport		R	S		Y	G	X			
FAA Facility										
			R	Y	G					
► OREGON RAIL TRANSPORTATION										
UPRR										
CA/OR State Line to Bieber Line Jct. (Klamath Falls)			Y	G	S	X				

<i>Infrastructure Facilities</i>	<i>Event Occurs</i>	<i>0 – 24 hours</i>	<i>1 – 3 days</i>	<i>3 – 7 days</i>	<i>1 – 4 weeks</i>	<i>1 – 3 months</i>	<i>3 – 6 months</i>	<i>6 – 12 months</i>	<i>1 – 3 years</i>	<i>3+ years</i>
Bieber Ln Jct. (Klamath Falls) to Chemult (Shared)			Y	G	S	X				
Chemult to Eugene					Y	G	S	X		
BNSF										
CA/OR State Line to Bieber Line Jct. (Klamath Falls)		G	S	X						
Chemult to Redmond		G	S	X						
Redmond to O.T. Jct. (connection with UP at Columbia)			Y	G	S	X				
► OREGON PUBLIC TRANSIT										
Admin & Maintenance Facilities ²⁾						R	Y	G	S	X
Local Area Paratransit On-Demand Service (critical)				R	Y	S	G	X		
Local Area Paratransit On-Demand Service (full)						R	Y	G	S	X
Local Roadway Fixed Route Service (emergency)				R	Y	S	G	X		
Local Roadway Fixed Route Service (regular)						R	Y	G	S	X
Intercity & Commuter Bus ⁴⁾						R	Y	G	S	X
Willamette Valley Zone										
► OREGON STATE HIGHWAY SYSTEM										
State Highway System - Tier 1 SLR ¹⁾			R	Y	G			S	X	
Roadways			R	Y	G		S	X		
Bridges			R	Y	G			S	X	
Landslides			R	Y	G			S	X	
State Highway System - Tier 2 SLR			R		Y	G		S	X	
Roadways			R		Y	G	S	X		
Bridges			R		Y	G		S	X	
Landslides			R		Y	G		S	X	
State Highway System - Tier 3 SLR				R		Y	G	S	X	
Roadways				R		Y	G	S	X	
Bridges				R		Y	G	S	X	
Landslides				R		Y	G	S	X	
State Highway System - Other Routes					R		Y	G	S	X
Roadways					R		Y	G	S	X
Bridges					R		Y	G	S	X
Landslides					R		Y	G	S	X
► AIRPORTS & AIR TRANSPORTATION ⁵⁾										
Tier I - Oregon Airports System										
Portland International Airport (PDX) (Tier 1)		R			Y	S		G	X	
Salem McNary Field		R			Y	S		G	X	
Eugene Mahlon Sweet Filed		R			Y	S		G	X	
Rogue Valley International Medford		R			Y	S		G	X	
Roseburg Regional Airport		R			Y	S		G	X	
Tier III Oregon General Aviation Airport System										
Troutdale			R		S	Y		G		X
Portland Heliport			R		S	Y		G		X
Aurora State			R		S	Y		G		X
McMinnville Municipal			R		S	Y		G		X
Corvallis			R		S	Y		G		X

<i>Infrastructure Facilities</i>	<i>Event Occurs</i>	<i>0 – 24 hours</i>	<i>1 – 3 days</i>	<i>3 – 7 days</i>	<i>1 – 4 weeks</i>	<i>1 – 3 months</i>	<i>3 – 6 months</i>	<i>6 – 12 months</i>	<i>1 – 3 years</i>	<i>3+ years</i>
Grants Pass			R		S	Y		G		X
Mulino State			R		S	Y		G		X
Albany Municipal			R		S	Y		G		X
Lebanon State			R		S	Y		G		X
Creswell Municipal			R		S	Y		G		X
Cottage Grove State			R		S	Y		G		X
Myrtle Creek			R		S	Y		G		X
Independence State Airport			R		S	Y		G		X
FAA Facility				R	Y	G	X			
► PORTS & WATER TRANSPORTATION										
<i>Port of Portland Terminals</i>			R			Y		G/S		X
► OREGON RAIL TRANSPORTATION										
UPRR										
O.T. Jct. to Troutdale			G	S	X					
Troutdale to Portland via Graham Line			Y	G	S	X				
Troutdale to Portland via Kenton Line			Y	G	S	X				
Eugene to Portland				Y	G	S	X			
BNSF										
Vancouver, WA to Portland					Y	G	S	X		
Portland & Western										
WES Commuter Rail, Wilsonville-Beaverton					Y	G	S	X		
► OREGON PUBLIC TRANSIT										
Admin & Maintenance Facilities ²⁾						R	Y	G	S	X
Local Area Paratransit On-Demand Service (critical)					R	Y	S	G	X	
Local Area Paratransit On-Demand Service (full)						R	Y	G	S	X
Local Roadway Fixed Route Service (emergency)				R	Y	S	G	X		
Local Roadway Fixed Route Service (regular)						R	Y	G	S	X
Intercity & Commuter Bus ⁴⁾						R	Y	G	S	X
Coastal Zone (Outside Tsunami Area)										
► OREGON STATE HIGHWAY SYSTEM										
State Highway System - Tier 1 SLR ¹⁾			R		Y			G	S	X
Roadways			R		Y			G/S	X	
Bridges			R		Y			G	S	X
Landslides			R		Y			G	S	X
State Highway System - Tier 2 SLR				R		Y		G	S	X
Roadways				R		Y		G	S	X
Bridges				R		Y		G	S	X
Landslides				R		Y		G	S	X
State Highway System - Tier 3 SLR					R		Y		G	S/X
Roadways					R		Y		G/S	X
Bridges					R		Y		G	S/X
Landslides					R		Y		G	S/X
State Highway System - Other Routes							R		Y	S/X
Roadways							R		Y/S	X

<i>Infrastructure Facilities</i>	<i>Event Occurs</i>	<i>0 – 24 hours</i>	<i>1 – 3 days</i>	<i>3 – 7 days</i>	<i>1 – 4 weeks</i>	<i>1 – 3 months</i>	<i>3 – 6 months</i>	<i>6 – 12 months</i>	<i>1 – 3 years</i>	<i>3+ years</i>
Bridges							R		Y	S/X
Landslides							R		Y	S/X
► AIRPORTS & AIR TRANSPORTATION ⁵⁾										
Tier II Oregon General Aviation Airport System										
Hillsboro Airport			R			Y	S		G	X
Newport Municipal Airport		R			Y		S	G		X
Scappoose Industrial Airpark Airport			R			Y	S		G	X
Tillamook Airport		R			Y		S	G		X
Bandon State Airport			R			Y	S		G	X
Brookings Airport			R			Y	S		G	X
Siletz Bay State Airport			R			Y	S		G	X
Cape Blanco State Airport		R			Y		S	G		X
Tier III Oregon General Aviation Airport System										
Florence Municipal Airport						R		Y	S	G/X
FAA Facility			R			Y	S		G	X
► OREGON RAIL TRANSPORTATION ⁶⁾										
Coos Bay Rail Link										
Eugene to Cushman (Siuslaw River near Florence)					Y	G	S	X		
Portland & Western										
Albany to Toledo					Y	G	S	X		
Willbridge (N.W. Portland) to Wauna				Y	G		S	X		
► OREGON PUBLIC TRANSIT										
Admin & Maintenance Facilities ²⁾						R	Y	G	S	X
Local Area Paratransit On-Demand Service (critical)					R	Y	S	G	X	
Local Area Paratransit On-Demand Service (full)						R	Y	G	S	X
Local Roadway Fixed Route Service (emergency)					R	Y	S	G	X	
Local Roadway Fixed Route Service (regular)						R	Y	G	S	X
Intercity & Commuter Bus ⁴⁾						R	Y	G	S	X
Tsunami Inundation Zone										
► OREGON STATE HIGHWAY SYSTEM										
State Highway System - Tier 1 SLR ¹⁾										
Roadways				R		Y			G	S/X
Bridges				R		Y			G	S/X
Landslides				R		Y			G	S/X
State Highway System - Tier 2 SLR										
Roadways					R		Y		G	S/X
Bridges					R		Y		G	S/X
Landslides					R		Y		G	S/X
State Highway System - Tier 3 SLR										
Roadways						R		Y		S/X
Bridges						R		Y		S/X
Landslides						R		Y		S/X
State Highway System - Other Routes										
Roadways							R		Y	S/X
							R		Y	S/X

<i>Infrastructure Facilities</i>	<i>Event Occurs</i>	<i>0 – 24 hours</i>	<i>1 – 3 days</i>	<i>3 – 7 days</i>	<i>1 – 4 weeks</i>	<i>1 – 3 months</i>	<i>3 – 6 months</i>	<i>6 – 12 months</i>	<i>1 – 3 years</i>	<i>3+ years</i>
Bridges							R		Y	S/X
Landslides							R		Y	S/X
► AIRPORTS & AIR TRANSPORTATION ⁷⁾										
Category I - Commercial Service Airports										
Southwest Oregon Regional Airport						R				X
Category II - Urban General Aviation Airports										
Astoria Regional Airport						R				X
Category IV - Local General Aviation Airports										
Seaside Municipal Airport									R	X
Gold Beach Municipal Airport									R	X
Category V - Remote Access/Emergency Service										
Nehalem Bay State Airport									R	X
Pacific City State Airport									R	X
Wakonda Beach State Airport									R	X
FAA Facility										
► PORTS & WATER TRANSPORTATION										
Port of Astoria										
Gateway Piers					R	Y	S	G	X	
Tongue Point					R	Y	S	G/X		
Mooring Basins				R	Y		S	G	X	
Boatyard				R	Y		S	G	X	
Channels				R	Y	S		G	X	
► OREGON RAIL TRANSPORTATION ⁶⁾										
Coos Bay Rail Link										
Cushman (Siuslaw R. near Florence) to Coos Bay &							Y	G	S	X
Portland & Western										
Wauna to Tongue Point/Astoria						Y	G	S	X	
► OREGON PUBLIC TRANSIT										
Admin & Maintenance Facilities ²⁾							R	Y	G	S/X
Local Area Paratransit On-Demand Service (critical)						R	Y	S	G	X
Local Area Paratransit On-Demand Service (full)							R	Y	G	S/X
Local Roadway Fixed Route Service (emergency)						R	Y	S	G	X
Local Roadway Fixed Route Service (regular)							R	Y	G	S/X
Intercity & Commuter Bus ⁴⁾							R	Y	G	S/X

TABLE NOTES:

1) SLR = Seismic Lifeline Routes (See Maps on Figure 5. 23 and 5. 24)

2) While temporary facilities can be used as an interim measure, it is anticipated that the prioritization of public relief funds would tend to push reconstruction of permanent transit facilities out into longer timeframes.

3) Critical needs evacuation and emergency usage of transit rolling stock would be at the direction of emergency operations center personnel.

4) Restoration of regular on-demand, fixed route, and intercity bus service is contingent on the extent of earthquake and tsunami damage, and on our ability to repair roads and bridges in all tiers of the state highway system and local roads.
5) Minimal level of service may indicate a heliport option only.
6) On these line segments, normal traffic is one train each way daily; consequently, restoration of minimal service means the same as functional.
7) Minimal level of service indicates the heliport option only. Due to the airport's proximity to the Pacific Ocean and elevation, the airport may be subject to relocation after the tsunami event.

Figure 5.22 – The current state of Oregon's transportation systems and the anticipated time to restore service after a Cascadia subduction zone event

HIGHWAY TRANSPORTATION

Sizable investments are needed to allow the highway system to be usable shortly after a major event. The total estimated cost to repair all seismically deficient bridges and unstable slopes is in the hundreds of millions of dollars; however, options exist for phased retrofitting that will provide the maximum degree of mobility with reasonable investments. The manner and timing of funding will influence how and where Oregon is prepared for rescue and recovery.

Analysis suggests that the longer the state delays increasing its investment in bridge and slope strengthening, the greater the cost and potential adverse effects an earthquake will have on the state's economy. If risks related to bridges and slopes are left unaddressed, the odds grow every day that we will be unprepared for an increasingly likely major earthquake. Oregon should therefore develop an investment package to begin a strategic retrofitting and replacement program for the state's bridges and unstable slopes. Securing both the interstate system in vulnerable areas and other key lifeline routes is the first priority, followed by critical city and county connector routes.

The strategic investment plan should be implemented in three tiers that build on each other. The Tier 1 routes listed in Figure 5. 23 (Phase 1 and then Phase 2) are considered top priorities for ensuring the greatest return on investment to support rescue and recovery operations. Strengthening Tiers 2 and 3 (Figure 5. 24) would follow as funding becomes available. This strategy anticipates that ODOT will continue bridge retrofits and slope strengthening in combination with other projects, even as it shifts to a more strategic, corridor-based approach to maximize potential future investments in seismic retrofitting.

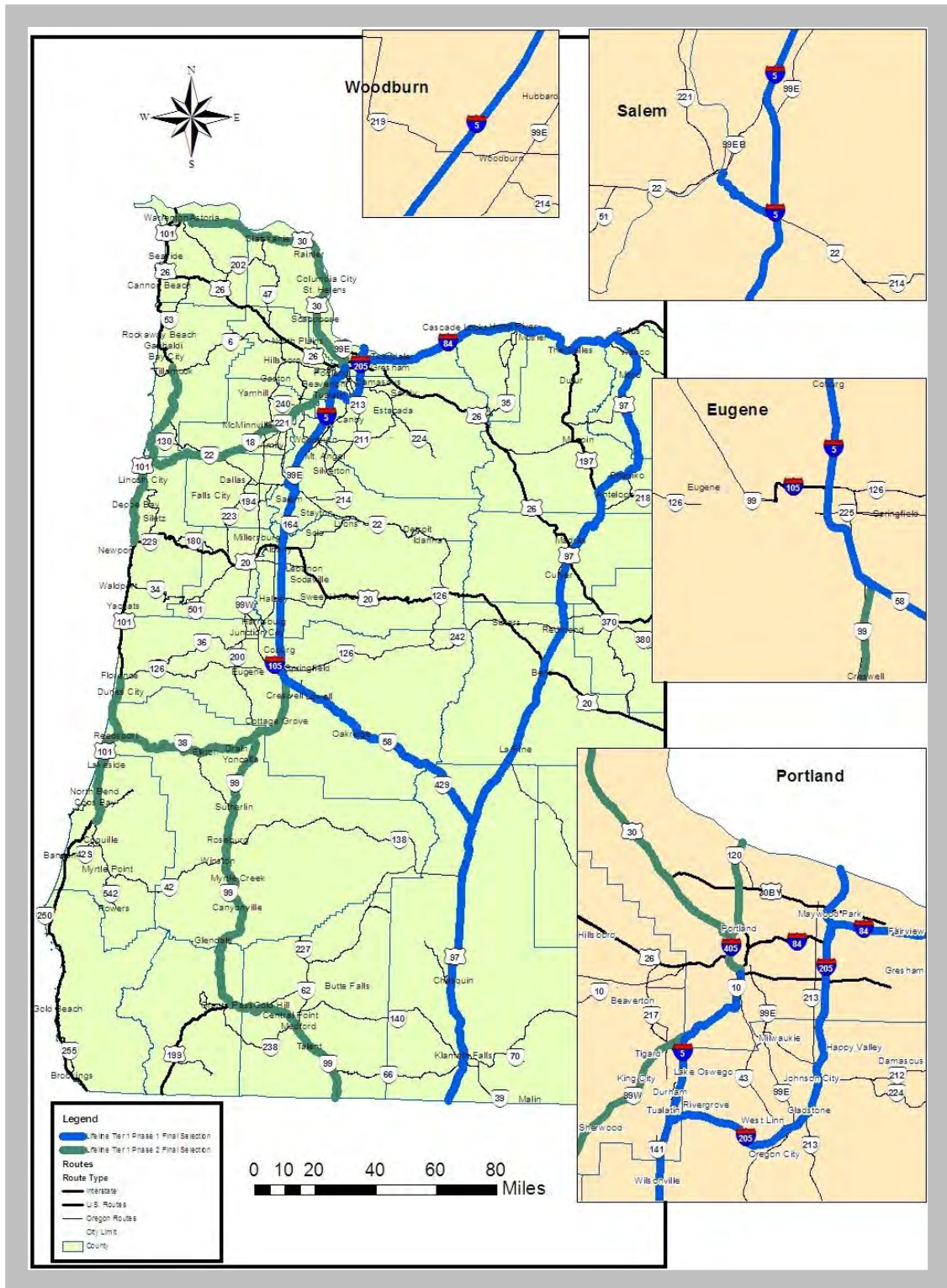

Figure 5.23 –Map of Seismic Options Program: Tier 1 Routes (Source: ODOT – Bridge Section)

RAIL TRANSPORTATION

A detailed vulnerability study and gap analysis should be done to identify strengthening and retrofit needs.

AIR TRANSPORTATION

A detailed vulnerability study and gap analysis should be done to identify strengthening and retrofit needs.

RIVER PORTS

A detailed vulnerability study and gap analysis should be done to identify strengthening and retrofit needs.

COASTAL PORTS

A detailed vulnerability study and gap analysis should be done to identify strengthening and retrofit needs.

PUBLIC TRANSIT SERVICES

A strategic investment strategy for public transit needs to start with the allocation of funds for gathering information, planning, and building collaboration with local and regional emergency planners. Specific projects for tactical hardening or relocation of certain transit structures and facilities may prove to be a valuable off-shoot of this effort, but in order to prioritize those and other potential expenditures, we first need to inventory and gather basic information about all transit resources in the four impact zones:

- An updated inventory of transit assets (buses, vans, fuel supplies, communications equipment, and repair facilities)—both those inside and those outside of the areas expected to be affected by the disaster—will be helpful. This should also include private carriers and school districts that may be of use in emergency response and recovery.
- An inventory of the assets of each facility, including general description, footprint, construction type, year built, and generator facilities, can provide a first-cut at seismic vulnerability estimation for those facilities that have not yet completed seismic assessments for a Cascadia-level event.
- Public transit needs to be included in emergency response preparations. As was recently revealed by Japan's Tohoku earthquake and the resulting tsunami impacts in Curry County and Del Norte County, transit agencies had not been at the table in emergency preparedness planning. A county-by-county assessment of transit's inclusion, role, and assigned activities for emergency preparedness should be conducted, and, where lack of involvement is indicated, inclusion and involvement should be formally encouraged.
- Assessment of the locations and needs of vulnerable and at-risk clients in all impact areas should be a priority. The lack of such information was a major factor in a number of deaths associated with Hurricane Katrina, many of which were potentially preventable. This is something each

local provider can do, with perhaps some general guidance and consistency of format provided at a statewide level.

- Transit agencies need to assess and prepare an inventory of routes, making note of the risk and vulnerability of both current transit routes and alternate routes; the inventory should identify alternate routes ahead of the actual event.
- Local transit providers should develop an emergency human resources plan that identifies:
 - Who their critical personnel are.
 - Where they live.
 - Full contact information.
 - Who is and who is not likely to be able to respond following an emergency.
 - Contingency plans for resuming at least minimal service using available and alternate personnel.
- Two aspects of preparedness should be considered for public transit: resilience planning and emergency response functions. These may include different roles for transit agencies, and they may entail different performance expectations. These differing roles and responsibilities need to be defined. The existence of mutual aid agreements with other local agencies and with nearby transit agencies should be identified; and, if do not exist, they should be encouraged as a means of building and sustaining collaboration and resilience.

LOCAL ROADS AND STREETS

As the strategic investment plan is implemented on the state highway system, certain elements of the local road and street system must also be retrofitted:

- In a few locations, critical emergency service facilities are separated from the state lifeline system by a substandard bridge. These bridges need to be retrofitted at the same time as the nearby state highway.
- Local road and street detours should be retrofitted wherever either of the following conditions exist:
 - The local road detour can be retrofitted for much less money than a retrofit on the section of state highway or bridge.
 - The local road detour can provide a substantially reduced time to restore the lifeline corridor to the minimal level of service for the use of emergency responders, repair crews, and vehicles transporting food and other critical supplies.

URBAN AREAS TRANSPORTATION

This chapter focuses mainly on statewide mobility between major hubs, cities, and towns. It is recognized, however, that travel within urban areas is also very important for rescue and recovery.

Large urban areas have critical needs for transportation resilience due to the relatively high volume of needs of a large population and the relatively high impact urban areas have on the state's economy.

Urban areas, such as Portland Metro, Eugene, Salem, Bend, Grants Pass, and Medford, face a large geographic barrier in the Columbia, Willamette, Deschutes, and Rogue Rivers and Bear Creek. These weak links in the urban transportation network create a potential for longer-term impacts because of the amount of time it is likely to take to restore traffic over large river bridges and to address problems caused by liquefiable soils along the river banks.

Most cities have established emergency response plans that identify critical facilities such as hospitals, fire stations, law enforcement facilities, schools, and emergency supply depots. Critical utility facilities, energy sources, and fuel depots are also needed for economic recovery. Access to these areas will be necessary to facilitate recovery, but specific modes and routes to provide this have not been identified in this study. This work is needed before a comprehensive plan for resilience can be finalized.

Transportation Interdependency Assessment

The Transportation Task Group determined that significant vulnerabilities exist for all transportation modes in western and central Oregon. While the desired approach is to raise the level of resilience of each mode by means of improvements programmed over a fifty-year timeframe, this may not be feasible due to the extremely high cost. The purpose of the interdependency effort was to select a multimodal transportation system that would provide the highest level of mobility to the largest area or to the highest population centers for the least cost.

The Transportation Task Group considered recommendations that would lead to a plan of measured improvements in ten-year increments that would include the most effective system of interconnected modes. The focus of this effort is to establish the resilience of portions of a transportation system—comprised of various modes—that would provide the greatest benefit for short-term rescue and longer-term economic recovery. To this end, the task group selected a minimum network of highway routes, termed a *backbone system*, and then supplemented it with other modes to provide statewide connectivity at what was perceived to be the lowest retrofit cost. The backbone system was identified as:

- I-5, from I-84 (Portland) to OR 58
- I-84, from I-5 (Portland) to U.S. 97
- U.S. 97, from I-84 to the California border
- OR 58, from I-5 to U.S. 97

Two alternate, interim transportation systems were assumed. The overall philosophy driving the selection process of the first system was that the movement of goods and people is likeliest, or most easily assured, along U.S. 97 (from both the north and the south and along the BNSF railroad line from

Klamath Falls), which also provides access to the Redmond airport in central Oregon. This assumption is supported by the low vulnerability of the highway, railroad line, and airport in comparison to routes and sites in western Oregon. The Redmond Municipal Airport was considered a key to short term mobility, because it would likely be available immediately following a Cascadia subduction zone earthquake. The Redmond airport should not need much investment to remain fully operational, although no specific study has been conducted to confirm this assumption. From the Redmond airport, goods and people would be easily distributed, by means of fixed-wing aircrafts, to Class 1 and commercial airports along the I-5 corridor. The task group considered this approach to be a high priority due to the high efficiency of fixed-wing aircrafts for moving people and freight. Goods and people would then access coastal areas by helicopter (a flight lasting approximately one half-hour each way). Airports in remote and coastal areas that can handle helicopters were identified as the second highest or moderate priority, with the resilience of the local roads and streets that provide access to those airports rated as equally important.

An alternate or redundant interim transportation system would serve Oregon from the west from ships, some anchored off shore for as long as needed. Goods and people would have access to the ships either through selected coastal ports hardened for use shortly after an event or by helicopter. Mobility from the ports to major population centers along the coast and inland would be achieved via hardened portions of U.S. 101 and selected local roads and streets.

The backbone highway system and seven airports are considered high priorities and should be made resilient within 10 years. The high-priority airports include:

- Redmond
- Portland International
- Salem
- Eugene
- Roseburg
- Medford
- Klamath Falls

Tier-1, Phase-2 Highway Lifeline Routes include segments of the coast highway (U.S. 101) and three highway segments connecting U.S. 101 to I-5. These segments should be considered moderate priorities as part of the multimodal transportation system. Airports designated as moderate priorities (to be hardened within 20 years) include:

- Scappoose/Hillsboro (one of these)
- Tillamook
- Siletz Bay (Lincoln City)

- Newport
- Florence
- Cape Blanco
- Brookings

North Bend and Astoria airports are very vulnerable, because they are both likely to be under water following a Cascadia subduction zone earthquake and tsunami. Both airports, however, may be potential recovery hubs due to the presence of the Coast Guard there. Unless the North Bend and Astoria/Warrenton facilities are completely destroyed, the Coast Guard intends to establish field facilities (tents/trailers) and begin operating those facilities as soon as possible after the event. (Airfields, which are unusable by fixed wing airplanes, may still be completely functional for helicopters as soon as the water recedes).

RAIL LINES

The task group considered the utility of rail lines in order to provide some redundancy to the basic backbone system, although nearly all the rail infrastructure predates modern seismic engineering standards. Rail lines into Redmond are considered a high priority, because Redmond is the hub for air transportation. The high priority mainline from Klamath Falls to Chemult is shared by BNSF Railway (formerly the Burlington Northern and Santa Fe Railroad) and UP (Union Pacific Railroad). The high priority BNSF mainline continues from Chemult to the Columbia River just west of Biggs. The UP mainline along the south side of the Columbia River from Portland to Idaho is also considered to be a high priority. The UP mainline from Chemult to Eugene and paralleling I-5 all the way to Portland is considered a moderate priority, because it is assumed that the cost of making the section through the Cascade Range resilient is very high.

All rail routes from the Willamette Valley to the coast are moderate to low priorities due to their vulnerabilities. The Coos Bay line could be functional to Reedsport after a Cascadia subduction zone event; but it is unlikely to be functional all the way to Coos Bay. The Tillamook line has been out of service since December 2007, with no plan for repairs. In general, short-line routes do not look very resilient, as they have not been built to current standards. There is very little rail redundancy outside of the Willamette Valley.

COASTAL AND RIVER PORTS

River and coastal ports are considered to be both part of a redundant system (in relation to the basic backbone system) and, in some cases, the primary access for specific areas. The task group considered it important to take into account the capabilities of the maritime industries, the Navy/Marine Corps, and the Coast Guard to bring in supplies by sea and distribute them to the state via air. The task group noted that this was done very effectively in Haiti.

River Ports

The Port of Portland has a very large capacity for handling supplies and is considered to be a major focus for restoring the economy after a seismic event. This port will be doing selective strengthening in the near future. The following upriver ports could provide significant supply links, although their levels of vulnerability and the vulnerability of the intervening locks still need to be confirmed:

- Arlington
- Morrow
- The Dalles
- Cascade Locks
- Umatilla

In addition, it was noted that the Port of St. Helens has a significant commodities capacity.

Locks are not designed to current seismic standards. In addition, seismic standards for locks are lower than for other structures. Seismic resistance is not an element of current evaluations conducted on river locks.

The overall plan needs to include a resilience evaluation of the Columbia River channel:

- An event could modify the channel's shape such that some larger vessels may not be able to navigate the river following an event.
- Dredging will likely be needed to restore the shipping channel following an event.
- Bridge failures could block the river for a period of time.
- The failure of dams or locks could block river navigation for an extended period of time.
- Elevation changes, subsidence, and other morphological changes could result in permanent changes to channels.

Coastal Ports

Coastal ports may be a significant lifeline for selected communities along U.S. 101. Immediately after a Cascadia subduction zone event, the coastal ports are not expected to be usable without some level of reconstruction. A detailed study is needed to determine whether there are practical ways to harden coastal ports so that they can be quickly restored and rendered operational. There is a study underway concerning identification of potential beach landing sites for naval vessels that would not require port facilities. The most practical solution may be to stockpile key resources at coastal locations. Such resources would include:

- Bailey bridges.
- Floating docks.

- Dredging equipment.

The task group recognized that storage of resources can be expensive, and consideration of deterioration and maintenance may lower the desirability of this option. Maintaining contingency contracts with local contractors who have the ability to repair structures or install temporary structures is considered a best practice.

Key roads are also needed to support port activity. Most of these connections are local agency routes that are considered to be the same level of priority as the coastal ports.

OTHER CONSIDERATIONS

- One of the issues that arose as the task group considered interdependencies is the lack of direct correlation between the modes. For example, air and water transport generally have definite take-off and landing points, although helicopters and beach landing craft can significantly extend the range of those modes to nonconventional landing areas. The highway system, on the other hand, has innumerable connections and no prescribed end points.
- Focusing simply on hardening the Phase 1 routes of OSLR Tier 1 will not ensure highway access to many coastal communities. If coastal communities are served primarily by air after an event, we would still need to consider local route resilience to make the most of the air corridors.
- The overall plan needs to take into consideration the potential for partial or complete failure of dams. Potential impacts and consequences of a failure could be extremely serious for rescue and recovery.

Alternate Routes

Selected local agencies were asked to assess the condition of their roads and streets in order to propose local bypasses (alternate routes) for the designated lifeline routes of the state highway system. The objective was to identify the places where the use of the local highway may be a more cost effective or practical means of making the transportation network resilient. Some examples are listed below.

- Klamath County proposed an 11-mile bypass of U.S. 97. This segment avoids the rockfall area north of Klamath Falls. Although this rockfall risk would be critical during an earthquake, the fallen rocks could be moved quickly out of the way shortly after the event. Moreover, the proposed bypass has liquefaction risk. The main north-south railroad is also next to the slide area. Because this railroad segment will be a Tier 1 facility, protection measures need to be planned. Such a protection scheme will likely protect both the highway and the railroad.
- Astoria suggested a route that runs parallel to U.S. 101 and bypasses Young's Bay Bridge. This parallel route has a few smaller bridges, would cost less to retrofit, and is at a higher elevation (no tsunami threat).

- Tillamook County noted an alternate route that parallels U.S. 101. This county route has small bridges and one major bridge, which is scheduled to be replaced in 2015. Connections to the airport and hospital would also need to be added.
- Albany suggested alternate north-south and east-west routes. The east-west route also connects to the hospital.
- Portland proposed priority local routes to hospitals, their lifeline routes on arterials connecting to the state highway lifeline routes, and connections to fuel depots.

Several other proposed local alternative routes are included in the [Local Agency Alternatives to State Highway Lifeline Routes \(http://www.oregon.gov/ODOT/HWY/BRIDGE/docs/laashlr.pdf\)](http://www.oregon.gov/ODOT/HWY/BRIDGE/docs/laashlr.pdf), a supplement to this Report. These routes will be studied at a later time as possible alternatives to state highway lifeline routes.

Public Transit

As noted earlier in this chapter, public transit agencies could play an important role in helping Oregon recover from a major natural disaster. The overall plan should therefore include funds to inventory public transit facilities and rolling stock (both inside and outside the projected impact areas) and to coordinate the integration of public transit into local and regional emergency relief and business recovery planning, including the development of mutual aid agreements where appropriate.

TRANSPORTATION INTERDEPENDENCY SUMMARY

The task group determined that no single transportation mode can be feasibly retrofitted to provide adequate mobility after a major Cascadia event for all areas of the state. A plan for strengthening particular components of each mode—to provide a combination of highway, air, rail, water ports, and local access roads—was developed that offers a cost effective strategy to increase mobility in incremental steps.



Recommendations

Recommendations for improving the resilience of transportation are based on the assumption that incremental improvements will be made over a 50-year timeframe. Phased investments to improve mobility are envisioned in order of priority and were chosen to best leverage cross modal improvements that will facilitate movement of goods and people on a multimodal transportation system. The recommended approach is to establish redundancy by routing people, supplies, and services from the east by air from Redmond Municipal Airport to hardened airports in the Willamette Valley, and by highway along I-84 and OR 58 to I-5 in the Willamette Valley to areas accessible by highways, and then by helicopter to isolated areas. Concurrently, people, supplies, and services would be able to travel from the sea through selected ports and then along portions of U.S. 101 or by helicopter to isolated areas.

Recommendations are presented for short-term goals and long-term goals.

SHORT-TERM RECOMMENDATIONS

- ▶ **Complete an updated inventory of local agency transit, port, and rail assets (such as service buildings, buses, vans, fuel supplies, communications equipment, repair facilities, and human resources, including identifying the needs of vulnerable and at-risk clients), assuring access to school buildings and hospitals, which could be used during emergencies.**
- ▶ **Complete a statewide evaluation, assessment, and gap analysis of:**
 - Local agency roads and streets, including public transit. (Define the roles of local agencies, transit, port, and railroads in resilience planning and assessment of alternate routes.)
 - Coastal and river port facilities, including jetties and breakwaters, the Columbia River channel (103.5 miles long, 43 feet deep, 600 feet wide), the levee system, dams and locks, port entrance channels, pile dikes, and specifically, Port of Portland facilities (including access to and the vulnerability of the four terminals that are interdependent with two rail lines, the river barge system, and two interstate highways) and the liquefaction vulnerability at Portland International Airport (PDX).
 - Railroads—specifically, the UPRR (Willamette Valley) and BNSF (Central Oregon) trunk north-south rail lines and three railroad short lines (Astoria District, Albany-Toledo, and CBRL) with access to coastal communities.
 - Ninety-seven public-use airports.
- ▶ **Encourage Federal agencies, such as USCG and the Corps of Engineers, to complete an assessment and gap analysis of Federal facilities that support transportation resilient planning.**
- ▶ **Develop a mitigation policy and retrofit plan for the assets and service facilities of vulnerable bridges, including all co-located utilities (such as power, communication, gas, water, and wastewater lines); rockfalls and unstable slopes; the 29 airports listed in the airport section of Chapter 5; river and coastal ports; the Columbia River channel, including emergency re-dredging options; local roads, streets, and transit; rail (on a corridor basis along the critical trunk and regional segments); and intermodal connections. Identify Redmond Municipal Airport (Roberts Field) as a key distribution point for other airports, and harden it as necessary so it will be operational after a major event; identify coastal and river ports or heliports as redundant access from ships stationed off shore for medical facilities and delivery of supplies from out of state, and the Columbia River as a priority with continued dredging. Encourage the development of formal cooperative assistance agreements with local agencies, nearby transit providers, rail providers, ports, and highway agencies.**
- ▶ **Continue to refine and gain consensus for the strategy contained in the interdependency section of Chapter 5 to optimize the recommendations for an incremental program for achieving resilience in western Oregon and to provide service to coastal areas and other potentially isolated areas with a combination of air, ports, regional rail, and highway segments, including**

consideration of the following airports and water transportation as the redundant first line of operational sites supporting lifeline highways:

- Redmond Municipal Airport
 - Portland International Airport
 - Salem Airport
 - Eugene Airport
 - Roseburg Airport
 - Medford Airport
 - Klamath Falls Airport
 - Scappoose/Hillsboro Airport (one of these)
 - Tillamook Airport
 - Siletz Bay Airport (Lincoln City)
 - Newport Airport
 - Florence Airport
 - Cape Blanco Airport
 - Brookings Airport
 - Selected Coastal and River Ports
 - Columbia River Channel
- ▶ **Enhance the proposed Highway Lifeline Maps by considering the use of highway segments owned by cities and counties to provide access to critical facilities. Prioritize local routes to provide access to population centers and critical facilities from the identified Tier-1 routes. When developing projects for seismic retrofit of highway facilities, consider whether a local agency roadway may offer a more cost effective alternative for all or part of a lifeline route.**

LONG-TERM RECOMMENDATIONS

- ▶ **Enhance design and maintenance standards and requirements for bridges and unstable slopes, transit, rail, ports, and airfields based on the priority of a lifeline route.**
- ▶ **Develop a temporary bridge installation policy and standards, including an assessment of the number of temporary bridges or amount of temporary bridge materials to stockpile for emergency use. Coordinate with the DOTs of neighboring states to create an inventory of (portable, temporary) Bailey bridges that includes notes on their locations and transportation methods. Consider procurement of additional temporary bridge materials.**
- ▶ **Support research on retrofit methods and strategies for Cascadia subduction zone earthquake loads. Support research on tsunami effects, and develop a design policy for tsunami loads.**

References

1. Atwater, B.F. and Hemphill-Haley, E. (1997). *Recurrence intervals for great earthquakes of the past 3,500 years at northeastern Willapa Bay, Washington*. USGS Professional Paper: 1576.
2. ODOT Bridge Seismic Committee and Peter Dusicka (2009). *Seismic Vulnerability of Oregon State Highway Bridges – Mitigation Strategies to Reduce Major Mobility Risks*. For detailed information, see <http://www.oregon.gov/ODOT/HWY/BRIDGE/Pages/index.aspx>
3. ODOT Technical Services Branch and Planning Division (2013). *Oregon Highways Seismic Options Report*. For detailed information, see <http://www.oregon.gov/ODOT/HWY/BRIDGE/Pages/index.aspx>
4. ODOT (2012). *Local Agency Alternatives to State Highway Lifeline Routes*, Supplement to Oregon Resilience Plan, Chapter 5 Transportation. For detailed information, see <http://www.oregon.gov/ODOT/HWY/BRIDGE/docs/laashlr.pdf>

6. Energy

Introduction

The Pacific Northwest has a high likelihood of a magnitude 9.0 earthquake on the Cascadia subduction zone, which would produce minutes of strong ground shaking, coastal subsidence, landslides, liquefaction, lateral spreads, and a coastal tsunami. Seismic provisions in Oregon’s building codes were first explicitly adopted in 1993. In contrast, Oregon’s critical energy infrastructure (CEI) is not governed by a uniform set of design and construction codes. Much of the existing CEI has been constructed with seismic design deficiencies. To minimize extensive direct earthquake damage, indirect losses, and possible ripple effects, substantial improvements to the critical energy infrastructure are necessary.

GOAL

The goal of the Energy Task Group is to provide policy recommendations to the state legislature to make Oregon’s critical energy infrastructure more resilient against a Cascadia subduction zone earthquake and tsunami within 50 years.

WHAT DOES BEING RESILIENT MEAN

The Oregon Seismic Safety Policy Advisory Commission (OSSPAC) has defined resilience as follows: *“Oregon citizens will not only be protected from life-threatening physical harm, but...because of risk reduction measures and pre-disaster planning, communities will recover more quickly and with less continuing vulnerability following a Cascadia subduction earthquake and tsunami.”*

SCENARIO

Because the impacts of the scenario M9.0 subduction zone earthquake and tsunami will vary depending on location, the steering committee recommended that, for the purposes of this study, the state be divided into separate regions. In addition to the tsunami, significant levels of shaking are expected, which will lessen in intensity the further one is from the coast.

The Energy Task Group adopted the following impact regions within Oregon, as recommended by the steering committee for all sectors:

- Coast/Tsunami Region: This is the part of the Oregon coast that is in or adjacent to the projected tsunami inundation zone.
- Coast/Seismic Region (earthquake-only): This is the part of the Oregon coast that is outside the tsunami inundation zone, but likely to experience peak ground acceleration (g) from .3 to .45.
- Willamette Valley Region: This region is likely to experience peak ground acceleration (g) from .15 to .3.

- Eastern Oregon Region: This region is likely to experience peak ground acceleration (g) from .01 to .15.

HISTORY

Over the course of the past five years, the Oregon Department of Geology and Mineral Industries (DOGAMI), the Oregon Public Utility Commission (OPUC), and the Oregon Department of Energy (ODOE) have been promoting awareness of the seismic vulnerabilities of Oregon’s critical energy infrastructure by communicating with local, state, and federal government officials, energy operators, Oregon citizens, and the media through high profile activities, such as the following:

- April 2, 2007—Conducted a full-day leadership forum and workshop on the seismic readiness of critical energy infrastructure. This event was held at the OPUC’s Main Hearing Room. The goal was to promote the importance of seismic vulnerability studies of critical energy infrastructures to utilities’ executives and senior engineers, bringing together speakers from across the United States with expert knowledge on seismic readiness. The workshop addressed four critical areas:
 - Cascadia earthquake hazards and risk
 - Critical energy infrastructure vulnerability to earthquake damage
 - State-of-practice lifeline seismic vulnerability studies and application
 - Case studies of vulnerability studies by BPA and Pacific Gas and Electric (PG&E)
- August 21, 2007—The OSSPAC chairman sent a letter (based on input from DOGAMI and the OPUC) to Governor Kulongoski and members of the legislative assembly. The letter, which emphasized the urgent need to ensure the reliability of energy in earthquakes, addressed several key points:
 - Restoration of electricity and gas after a localized earthquake event are likely to be addressed relatively quickly, depending on the level of damage, with support for response coming from the region and potentially from across state borders.
 - Because of the potentially catastrophic impacts to critical energy infrastructures, the restoration of the energy sector after a Cascadia subduction zone earthquake is expected to take much longer should it occur today. The initial and immediate response, such as obtaining emergency generators for critical facilities, will likely require assistance from the Oregon National Guard and from other states.
 - The critical element of educating Oregonians on their level of responsibility should ideally be done in cooperation with the other West Coast states and the Canadian province of British Columbia so that everyone affected will be receiving the same information on how to be self-sustaining. Without exception, everyone on the West Coast will be assuming more responsibility (public, private, personal), so the better informed and educated people are, the more responsive everyone will be when the need to help each other arises.

- The letter also recommended that the governor take three immediate actions:
 - Oregon needs to mobilize on vulnerability assessments of pre-disaster inventories and systems.
 - Oregon needs to form cooperative agreements (by a specified timeframe) with other states before the earthquake disaster. These states should include Idaho, Utah, and others east of Oregon. Agreements should include the Oregon PUC. Note that making arrangements after the disaster would be inefficient. It is appropriate to acknowledge that the natural gas and electric IOUs and many COUs already have mutual aid agreements in place with other operators, some well outside the potentially affected areas.
 - Proactive education is needed for families and individuals; this should include instructions to be self-sustaining for weeks or months (not days). Without personal preparedness, local and state agencies and private companies alike will not have the personnel/staff they need to meet the multitude of demands involved in emergency response.
- August 26, 2009—ODOE, DOGAMI, and OPUC, via a hazard mitigation grant, conducted a Seismic Event Tabletop Exercise with most energy and fuel operators in the northwest industrial area of Portland (on the Willamette River). About five miles of the riverfront in this area near the St. Johns Bridge includes a concentration of critically important infrastructure on very poor soils that are highly susceptible to earthquake-induced permanent ground deformation. The purpose of the exercise was to promote awareness and resilience of critical energy infrastructures in Oregon. The outcomes were used to better understand the risk associated with earthquake hazards, and findings were shared with city and state leaders. One result of the exercise was to increase the urgency of taking immediate pre-disaster mitigation steps, preparing to take additional steps in the future, and improving planning for future disasters. Another result was a proposal to advance the seismic portion of the OPUC safety and reliability audits by specifying requirements for seismic vulnerability assessments. This work provided the basis for the Energy Assurance Plan Grant with NASEO.
- January 04, 2010—ODOE in partnership with OPUC and DOGAMI (Team) applied for the Energy Assurance Program (EAP) Initiative sponsored by the National Association of State Energy Offices (NASEO). The grant program required completion of the EAP within three years. The Oregon EAP was completed this past June (Wang et al., 2012). The main goal of establishing an Energy Assurance Plan for Oregon was to help all stakeholders make the state of Oregon resilient against any major incident, catastrophic or otherwise, so that Oregon will not go for long periods of time without the proper energy supply to meet its needs. In the application process, the Team identified the Cascadia subduction zone earthquake as the most severe catastrophic event Oregon will experience. With this perspective, the Team focused its attention

on the most vulnerable energy area in our state, which was identified in the Hazard Mitigation Grant Tabletop Exercise, addressed above.

The Energy Assurance Plan and Oregon’s Critical Energy Infrastructure Hub

The Energy Assurance Plan (EAP) (Wang et al., 2012) has become the main plan for our state, and even though it is focused primarily in the NW Industrial area of Portland along the Willamette river (CEI Hub), its findings and recommendations are applicable throughout the state’s western region. It is also appropriate to acknowledge that the EAP work has been the driving force behind the Energy Task Group in its pursuit of policy recommendations to make our critical energy infrastructures resilient against a Cascadia subduction zone earthquake. Six magnitude 5.0 or greater earthquakes have occurred within the Portland metropolitan area in the past 150 years. The Cascadia subduction zone has produced more than 40 large magnitude earthquakes in the past 10,000 years. The most recent, which occurred on January 26, 1700, was an estimated magnitude 9.0. These occurrences and extensive scientific understanding of seismic processes indicate that it is highly likely that a Cascadia subduction zone earthquake will strike the region again.



Figure 6.1: Fuel tank farms and marine terminals along the Willamette River’s edge near US Highway 30. For geographic reference to Figures 29 and 31, note the three parallel water inlets (Basemap: Google Earth)

Oregon’s critical energy infrastructure hub (CEI Hub) covers a six-mile stretch on the lower Willamette River between the southern tip of Sauvie Island and the Fremont Bridge on U.S. Highway 30. This relatively small area in Portland is the site of liquid fuel, natural gas, and electrical infrastructure and facilities; it is also an area with significant seismic hazard. The energy sector facilities in the CEI Hub include:

- All of Oregon’s major liquid fuel port terminals.
- Liquid fuel transmission pipelines and transfer stations.
- Natural gas transmission pipelines.
- A liquefied natural gas storage facility.
- High voltage electric substations and transmission lines.
- Electrical substations for local distribution.

More than 90 percent of Oregon’s refined petroleum products come from the Puget Sound area of Washington State. Oregon imports the liquid fuel by pipeline and marine vessels; it passes through the CEI Hub before it is distributed throughout Oregon to the end users. (One large consumer is the Portland International Airport.) In addition, a portion of the state’s natural gas fuel supply passes through the CEI Hub; and a high voltage electrical transmission corridor both crosses the area and supplies power to it.



Figure 6.2: Site Map of the Critical Energy Infrastructure (CEI) Hub on the western bank of the Lower Willamette River area in NW Portland, Oregon. The CEI Hub, outlined in red, stretches for six miles. (Google Earth)



Figure 6.3: Oil Terminals in the CEI Hub. (DOGAMI photo)

EARTHQUAKE RISK STUDY FOR THE CRITICAL ENERGY INFRASTRUCTURE HUB

The Oregon Department of Geology and Mineral Industries (DOGAMI) conducted an earthquake risk study on Oregon’s CEI Hub as part of the Oregon Energy Assurance Project (EAP) with the Oregon Department of Energy (ODOE) and Public Utility Commission of Oregon (OPUC). The study focuses on a large-magnitude Cascadia earthquake, which, because of widespread shaking and vulnerable infrastructure, poses a high risk to the health and safety of Oregonians and the region’s economy. The study identifies and defines the CEI Hub area, assesses the seismic hazards, and identifies the vulnerabilities of the petroleum (liquid fuel), natural gas, and electrical energy facilities in the CEI Hub.

Oregon’s Natural Hazards

Oregon has numerous natural hazards. These range from high probability (fires) to low probability (volcanic eruptions). Earthquakes are considered to have a moderate probability because earthquakes in Oregon are rare. The earthquake vulnerability score for Oregon, however, is very high because a portion of Oregon’s existing infrastructure has been designed and constructed without seismic resistance considerations. The earthquake consequence score is also very high because damage will likely be widespread and, in many places, severe. Finally, the earthquake overall risk score is very high because when a major earthquake occurs, it may result in loss of life, economic damages, and long-term impacts.

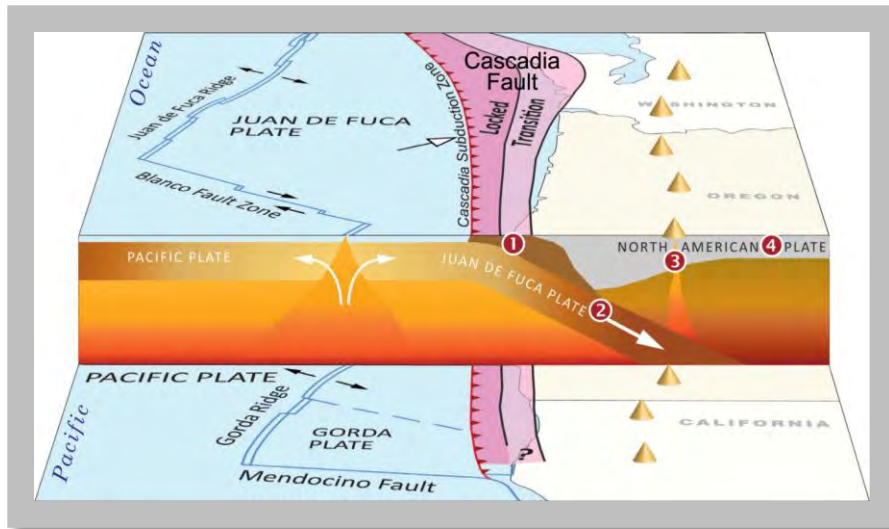

Figure 6.4: Cascadia seismic source is Oregon's most threatening fault and can produce a magnitude 9 earthquake and accompanying coastal tsunami waves. (Source: DOGAMI)

Potential Effects of an Earthquake

A portion of Oregon's electricity and natural gas infrastructure, as well as a majority of its fuel oil infrastructure, is concentrated in the CEI Hub. A magnitude 8 or 9 Cascadia subduction zone earthquake would impact the CEI Hub with:

- Ground shaking
- Liquefaction (a phenomenon in which a water-saturated soil, such as sand, softens and loses strength during strong earthquake ground shaking)
- Lateral spreading (where layers of soil at the surface of the land permanently move laterally due to earthquake shaking)
- Landslides
- Co-seismic settlement (where the ground surface is permanently lowered due to seismic shaking)
- Bearing capacity failures (when the foundation soil cannot support the structure it is intended to support)

In addition, secondary seismic hazards could be initiated. These include:

- Seiches (waves that oscillate in water bodies; such waves are often initiated by ground shaking)
- Fire
- Hazardous material releases (including by sloshing of liquid agitated by ground shaking)

- Tsunamis (Tsunami waves are expected to damage coastal areas, including ports along the coast and Columbia River mouth, but are not expected to cause significant damage in Portland’s waterways.)

Liquefaction and lateral spreading hazards are of primary concern to the oil terminals that handle Oregon's liquid fuel supply. The CEI Hub is adjacent to the Willamette River and has extensive deposits of highly liquefiable soils. These soils (made of sands, silts, gravels, and clays) have been deposited both by natural river activity and by human activities, such as the hydraulic placement of material dredged from the river or debris deposited as landfill. For this reason, DOGAMI performed ground deformation analyses to better understand the nature of the hazard and the possible mitigation that will be needed to address it. A section on the deformation analyses is included in this study.

Energy Facilities in the CEI Hub

DOGAMI staff and others visited all relevant energy companies with facilities in the CEI Hub. DOGAMI and ODOE staff conducted site visits at these petroleum facilities: BP, Chevron, ConocoPhillips, KinderMorgan (KM) fuel terminals and pipeline, McCall Oil, Nustar, and Shell. The liquid fuel facilities often include transmission and distribution pipelines, piers or wharves, tank farms, loading racks, control buildings, electrical distribution equipment, and many other components. The liquid fuel transmission system includes gate stations and transmission and distribution pipes at the Columbia and Willamette river crossings. DOGAMI and OPUC staff also conducted site visits of natural gas and electrical facilities owned by NW Natural, Portland General Electric, and the Bonneville Power Administration (BPA).

General Findings

The CEI Hub facilities have infrastructure that ranges from about 100-years-old and built to no or very antiquated standards to new infrastructure built to the current state-of-practice standards. Because of the wide range of ages and associated construction practices, the seismic vulnerability of the facilities also spans a wide range. Based on visual observations, engineering judgment, and information from facility operators, major seismic vulnerabilities exist in the CEI Hub. The vast majority of the facilities are constructed on soils susceptible to liquefaction. Some critically important structures appear to be susceptible to significant damage in a major earthquake, while structures that were installed more recently are expected to have better seismic performance. In addition, DOGAMI discovered that older building codes and practices did not adequately address many non-building structures that exist in the CEI Hub, such as tanks, pipes, and piers. Current building codes do not adequately address the seismic deficiencies in existing CEI Hub facilities.

Sector Specific Findings

- Liquid Fuel
 - *Liquid fuel pipeline:* The CEI Hub’s petroleum facilities receive liquid fuel via two methods: 1) the liquid fuel transmission pipeline and 2) marine vessels. The

transportation method and amounts vary due to product demand, transportation costs, weather, and other conditions. The liquid fuel pipeline was largely constructed in the 1960s when the regional seismic hazards were unknown and state-of-practice construction techniques did not include any reference to seismic standards. The regional seismic hazards are now known to be significant, and the soils at the river crossings are known to be susceptible to liquefaction and lateral spreading. The 1960s vintage pipeline design did not consider ground movements from lateral spreading at river crossings or other earthquake-induced stresses on the pipelines that may cause damage and multiple breaks. A break in the pipe would have a significant impact on all of the petrochemical facilities in the CEI Hub and could result in a statewide fuel shortage.

- *Liquid fuel supply:* Liquefaction vulnerabilities are known to have been addressed in the case of only three existing tanks. The tank farms in the fuel terminals of the CEI Hub have on average a three- to five-day supply of regular unleaded gasoline and diesel fuel. Premium gasoline is subject to daily delivery and is heavily dependent on whether the intercompany pipeline on Front Avenue is operational. If the supply chain is disrupted by pipe breaks north of the CEI Hub and by closure of the shipping channel to the west, fuel would quickly become scarce. Options to transport fuel from the east and south and by air are very limited.
- *Shipping channel:* The navigational channel from the mouth of the Columbia River to the lower Willamette River is used by marine vessels to transport fuel. The mouth of the Columbia River is expected to have tsunami damage, and the channel is expected to experience slope failure, which would close the channel to traffic. It is possible that bridges and other overhead river crossings would also be damaged and could temporarily block the waterway. Closure of the shipping channel would prevent marine vessels from delivering either liquid fuel or emergency response and recovery equipment.
- *Marine terminals:* All of the port facilities in the CEI Hub have significant seismic risks due to liquefaction, lateral spreading, and seiches. Some older piers were constructed without any seismic protection, have deteriorated, and are likely to fail even in a moderate earthquake. If oil products are released and contaminate the navigable waterway, the waterway may be closed to river traffic, thus impeding emergency response activities as well as the supply chain. The local capacity to fight fires and clean up hazardous material spills is limited.
- *Portland International Airport (PDX):* PDX airport receives 100 percent of its liquid fuels from a terminal in the CEI Hub. The airport has a limited on-site fuel supply. If the pipeline between the CEI Hub and the airport fails, then the airport would likely experience a shortfall, and operations would be impacted.

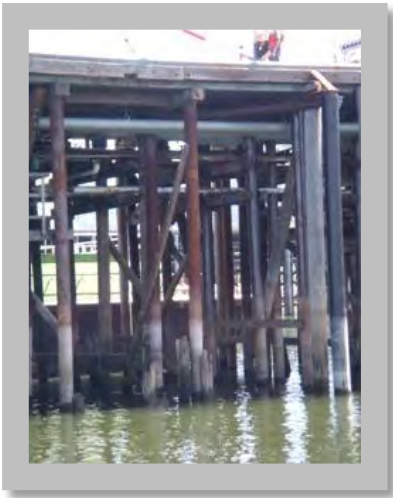

Figure 6.5 Lateral timber bracing for steel plumb piles in the CEI Hub is considered inadequate by California's MOTEMS standards. (DOGAMI photo)

Figure 6.6: An example of a damaged pier in the 2010 Chile earthquake (ASCE Technical Council on Lifeline Earthquake Engineering – TCLEE, 2010)

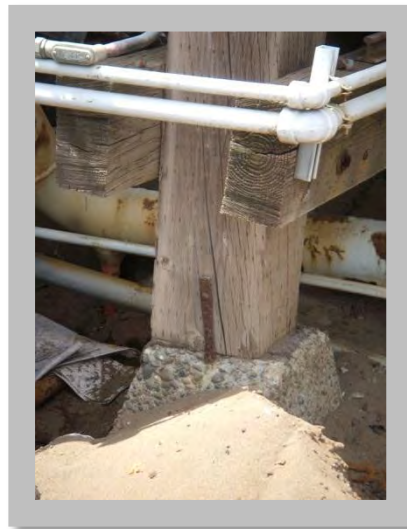

Figure 6.7 and 6.8: This under-designed oil terminal pier foundation (left) in area with high susceptibility for liquefaction and lateral spreading in the CEI Hub and the poor timber-to-concrete oil terminal pier connection and exposed rebar foundation (right) in the CEI Hub are considered inadequate (Source: DOGAMI photo)



Figure 6.9: The connection on this pier in the CEI Hub appears to have deteriorated due to a split in the timber beam. This type of damage suggests that the condition of the structure may not be routinely monitored and maintained and that the overall pier is seismically vulnerable (Source: DOGAMI photo)



Figure 6.10: The approach (foreground) to the 1966 Astoria-Megler Bridge that spans the Columbia River has major structural deficiencies that could lead to a collapse following an earthquake. Damaged bridge sections could block waterway access to the CEI Hub. (DOGAMI photo)

- Natural Gas. Oregon's largest natural gas service provider receives the majority of its natural gas from pipelines that cross under the Columbia River near St. Helens, Sauvie Island, and also between Washougal, Washington, and Troutdale, Oregon. One of the natural gas pipelines crosses under the Multnomah Channel near the gate station at the southern end of Sauvie Island. The soils at these river crossings are subject to liquefaction and lateral spreading, and the pipes are of 1960s vintage. However, natural gas pipelines constructed after the mid-1950s have been found to perform very well during significant seismic events. Oregon's largest natural gas

supplier has the strategic advantage of on-system storage (within the company's service territory), which would allow the company to provide natural gas service to unaffected customers while any damaged natural gas pipelines supplying the area are being restored.

- Electricity
 - Electrical facilities and systems have significant seismic risk due to ground shaking and ground failure, including liquefaction and lateral spreading. Seismically vulnerable facilities include substations and transmission lines in the CEI Hub as well as facilities outside of the CEI Hub, including power plants, substations, and transmission lines, all of which are important for distribution. Major vulnerabilities in the CEI Hub include the control buildings, transformers, and other electrical equipment in yards at the substations, and transmission towers near the Willamette River. Damage is likely to occur to both the transmission system and the distribution system in the CEI Hub. Damage to the electrical grid will likely result in a blackout in the CEI Hub and elsewhere.

Findings of the Bonneville Power Administration

Bonneville Power Administration (BPA) has conducted a comprehensive seismic vulnerability study of their system and has had a long-term seismic mitigation program in place since 1993. This program includes:

- Investment protection (e.g. anchoring transformers).
- Power system recovery of critical paths (e.g. hardening of equipment at one of multiple bays within a major substation).

The first phase of BPA's mitigation program includes bracing and restraining critical equipment and seismically upgrading critical building facilities west of the Cascade Range. Seismic strengthening in the substation yard would typically include: anchoring high-voltage power transformers, bracing transformer conservators and radiators, replacing seismically vulnerable live tank circuit breakers with more robust dead tank circuit breakers, adding damping systems to existing live tank circuit breakers, hardening transformer bushing storage facilities, and replacing rigid bus connections with flexible bus. These mitigation techniques will improve the reliability of seismic performance. Additional phases of the seismic mitigation program will include facilities east of the Cascade Range.

BPA has a critical 115 kV and 230 kV high voltage transmission river-crossing in the CEI Hub as well as a substation. At the substation in the CEI Hub, some of the high-voltage equipment had been anchored and braced to withstand earthquake motions. BPA is in the process of conducting seismic strengthening of the control building and equipment inside the control building (for example, bracing computer floors, control cabinets, battery racks, ceilings, and pipes) and additional mitigation in the yard. BPA has conducted subsurface, liquefaction and lateral spreading analyses at one of the transmission tower sites at the Willamette River crossing and has concluded that severe ground movement (up to 25 feet)

towards the river channel is possible. Until mitigated, it is likely that at least two transmission towers would experience extensive damage, be inoperable, and require repair or replacement; and power lines could temporarily block river traffic, including the pathway to the oil terminals. The BPA transmission towers at the Willamette River crossing are scheduled to be seismically analyzed, to have a seismic mitigation design completed in 2013, and to be mitigated by 2014.

Recent unpublished BPA Cascadia earthquake scenario studies of the existing transmission line system indicate that BPA's main grid would require between 7 and 51 days for completion of emergency damage repairs to the transmission line system (Oregon and Washington) after a magnitude 9.0 Cascadia earthquake. This scenario assumes many ideal conditions (for example, that BPA employees and contractor resources are immediately available, all roads and bridges are passable, and sufficient fuel is available), which is optimistic.



Figure 6.11 and 6.12: Left: These high voltage electrical transmission towers are built on a river bank in the CEI Hub susceptible to lateral spreading. (DOGAMI photo) Right: Structural damage to a high voltage transmission tower located at a river crossing in 2010 Chile earthquake. (ASCE Technical Council on Lifeline Earthquake Engineering – TCLEE)

Impacts to Oregon

Based on visual observations, engineering judgment, limited analyses, information from the facility operators, city records, and available literature, significant seismic risk exists in the CEI Hub. Some critically important structures appear to be susceptible to substantial damage in a major earthquake—with catastrophic consequences. Breaks in liquid fuel and natural gas transmission pipes are possible. Damage to liquid fuel, natural gas, and electrical facilities in the CEI Hub is also possible. The waterway may be closed as a result of the damage and may need to be cleaned up before it can be reopened.

Due to the existing seismic hazards, the vulnerability of the exposed infrastructure, and the potential consequences of an earthquake given both these factors, Cascadia earthquakes pose substantial risk to the CEI Hub and to Oregon. Not only are the energy sector facilities in the CEI Hub dependent on other sectors and systems in Oregon, including transportation and communication, they are interdependent

upon each other. A major Cascadia earthquake and tsunami would likely produce impacts larger than any event the state has previously faced. Western Oregon may face a temporary electrical blackout, isolated natural gas service outages, and liquid fuel shortages. Mitigating the risk that a future major Cascadia earthquake poses to the energy sector can lessen energy infrastructure damage and enable faster recovery of services to support other critical lifeline services.

OPERATOR EFFORTS TO PREPARE FOR A CASCADIA SUBDUCTION ZONE EVENT

For decades, the energy sector has recognized the need to prepare its systems for seismic events and other disasters that could have an impact on customers, and energy operators have made progress toward improving their resilience to a major seismic event. Operators are constantly updating and replacing their energy infrastructure, and in the process of replacement, they upgrade the new facilities to current design standards.

Energy providers comply with federal standards and regulations related to the siting, design, construction, and safe operation of infrastructure to make sure that risks, such as earthquakes, are evaluated and addressed as necessary to ensure the safe and reliable operation of the electrical grid and interstate and intrastate natural gas pipelines. At the state level, the providers of those utilities regulated by the Public Utility Commission of Oregon meet on a regular basis to provide updates to regulators regarding their preparations for disasters and response and to continually evaluate how they can improve and strengthen energy systems.

Within the energy sector, the operators improve their approach to building resilient systems by participating in professional organizations that set the industry's standards and address risk evaluation. Further benefits are gained from interaction with companies that have experienced low frequency, high impact events, such as earthquakes, because these companies are able to share tactics that proved to be beneficial in preparing and recovering from such events. Moreover, the operators have entered into mutual aid agreements with other energy providers outside the region. Such agreements will make it possible to mobilize significant quantities of skilled personnel and materials to support the response to a major natural forces disaster. Finally, on an ongoing basis, the operators have built internal planning processes to ensure an orderly and effective response to any event that significantly disrupts business operations. These actions are significant and have made the energy sector better prepared to respond to major events today than it was previously.

Over the past 25 years, NW Natural has implemented an aggressive, enhanced pipeline safety program to replace older infrastructure that may not be as resilient to a Cascadia subduction zone event. The company completed the replacement of all cast iron pipe in 2000 and will complete the replacement of its bare steel piping infrastructure in the near future. The current underground piping systems have a high level of ductility (flexibility) which allows the pipe to perform well in a seismic event. Since 2002, the company has implemented new Integrity Management Programs for its transmission and distribution systems to address threats (including seismic events) to the safe and reliable operation of the pipelines.

Expected Service Restoration Time Frames

The expected service restoration time frames (see Figure 6.13) are based on the assumption that roads and telecommunications are functioning so as to support restoration of the energy infrastructure. In areas where service restoration is impractical, the service provider is not expected to meet the restoration timeframes. Establishing target timeframes for the tsunami inundation zone, beyond a minimal level of capability to support response, is not practical. For that reason the tsunami inundation region is not depicted in the matrix presented below. A large amount of planning and prioritizing will need to be undertaken to identify which areas will be rebuilt first.



Recommendations

- ▶ **The Oregon Public Utility Commission (OPUC) should provide oversight for the seismic preparedness of those energy providers that are currently jurisdictional.**
- ▶ **Develop regulatory oversight for energy sector companies that are not regulated by the OPUC and create engagement in seismic mitigation efforts for those companies, including appropriate cost recovery for such oversight function.**
- ▶ **The state should provide immunity of liability, in statute, for those seismic vulnerabilities that are identified by the operators during their seismic vulnerability assessments.**
- ▶ **To identify vulnerabilities of operator-defined Critical Energy Infrastructure (CEI) facilities, energy sector companies should conduct seismic vulnerability assessments. Operators should then develop plans to mitigate the seismic risks associated with the identified CEI vulnerabilities.**
- ▶ **Energy sector companies should institutionalize long-term seismic mitigation programs and should work with the appropriate oversight authority to further improve the resilience and operational reliability of their Critical Energy Infrastructure (CEI) facilities.**
- ▶ **Form a public-private partnership with the objective of reducing the state’s vulnerability to seismic events by evaluating the diversification of locations for the storage of liquid fuels and identification of new liquid fuel energy corridors (new locations to be defined).**
- ▶ **The state of Oregon should require that, in emergency situations, liquid fuel wholesale and retail operators provide both access to and alternate means of delivering fuels to the end users.**
- ▶ **Evaluate the options for improving power supply to coastal areas located outside of the tsunami inundation zone.**
- ▶ **Utilize the Oregon Office of Emergency Management’s public-private sector position to help ensure coordinated planning, information sharing, and interoperability among critical organizations and agencies. The position will also ensure that work being performed by this entity and its partners helps provide public education and outreach to local, county, and state agencies and organizations.**

- The state of Oregon should provide statutory authority for a prescriptive waiver of routine permitting requirements and processes for the design, construction, and restoration of energy infrastructure and subsequent actions, if it is determined that the waiver is in the public interest and is necessary to address an actual or impending emergency caused by a natural or manmade disaster.

ENERGY SECTOR											
Target Timeframe For Recovery											
KEY TO THE TABLE											
	Desired time to restore component to 80-90% operational - In 50 Years							Resilient	G		
	Desired time to restore component to 50-60% operational - In 50 Years							Resilient	Y		
	Desired time to restore component to 20-30% operational - In 50 Years							Resilient	R		
	Current state restoration to 90% operational							Today	X		
TARGET STATES OF RECOVERY											
Event Occurs	0-24 Hours	1 - 3 Days	3-7 Days	1 - 3 Weeks	3 Weeks - 1 Month	1 Month - 3 Months	3Months - 6 Months	6 Months - 1 year	1 year - 3 Years		
ELECTRIC											
All - see notes below											
ZONE: WILLAMETTE VALLEY											
Transmission					X						
Substation					X	X					
Distribution					X						
NATURAL GAS											
Transmission					X						
Gate Stations					X						
Distribution					X						
LIQUID FUEL											
Transmission											
Storage											
ELECTRIC											
All - see notes below											
ZONE: EASTERN OREGON											
Transmission			X								
Substation			X	X							
Distribution			X								
NATURAL GAS											
Transmission					X						
Gate Stations					X						
Distribution					X						
LIQUID FUEL											
Transmission											
Storage											
ELECTRIC											
All - see notes below											
ZONE: COAST (Non Tsunami Zone)											
Transmission					X						
Substation					X	X					
Distribution					X		X				
NATURAL GAS											
Transmission					X						
Gate Stations					X						
Distribution					X						
LIQUID FUEL											
Transmission											
Storage											

Restoration Status Assumptions - Cascadia Subduction Zone Earthquake	
1-	Transportation routes including roads, airports, bridges, etc. will be available for energy provider use to perform assessments, deliver materials and rebuild infrastructure as required.
2-	All fuel needs will be available to support energy provider restoration operations.
3-	For areas dependent upon third party electric transmission providers, restoration times assume their system will be available to support restoration efforts.
4-	Interstate gas transmission pipelines will be able to provide service in advance of the restoration times for local distribution.
5-	Roseburg / Medford areas are included with Willamette Valley for evaluation purposes.
6-	The % of restoration references it to customers who are able to take natural gas or electric service delivery.
7-	Communication systems will be available for energy provider's use.
8-	For Pacific Power the coastal service territory includes a combination of tsunami and non-tsunami prone areas. Where facilities provider service to non-tsunami prone areas pass through or reside in tsunami impact areas, the estimated impact of tsunami on these facilities is included in restoration times.
9-	The State of Oregon has provided statutory relief and/or waiver from typical permitting requirements and processes associated with the design, construction and/or restoration of the energy infrastructure.
10-	The bulk of generation is outside of the Willamette Valley, so the focus is on the Transmission.

Figure 6.13: Energy Sector Target Timeframe for Recovery

References

1. Wang, Y., Bartlett, S.F., and Miles, S.B. (2012). *Earthquake Risk Study for Oregon's Critical Energy Infrastructure Hub*. Final Report to Oregon Department of Energy & Oregon Public Utility Commission. Oregon Department of Geology and Mineral Industries, August. The full EAP report is accessible at <http://www.oregon.gov/puc/docs/DOGAMICEIHubreport-8-1-12-R1.pdf>.
2. Nojima, N. (2012). "Restorations and System Interactions of Lifelines in the Great East Japan Earthquake Disaster, 2011," *Proceedings of the International Symposium on Engineering Lessons Learned from the 2011 Great East Japan Earthquake*, March 1-4, Tokyo, Japan.
3. ASCE TCLEE (2011). *Preliminary Report on the 27 February 2010 Mw 8.8 Offshore Maule, Chile Earthquake*. Technical Council on Lifeline Earthquake Engineering (TCLEE), American Society of Civil Engineers.

7. Information and Communications

Introduction

Oregon's information and communication systems are especially vulnerable to damage resulting from a Cascadia subduction zone earthquake. Some of the inherent seismic vulnerabilities of the systems include the following:

- The systems are highly dependent on other resources—such as power and transportation as well as skilled staff—to remain operational and to complete needed repairs.
- The systems are financially dependent on consistent revenue streams to fund ongoing operations, maintenance, and debt service obligations.
- Essential facilities, including central offices and towers, are often located in areas that make them vulnerable to damage from liquefaction of alluvial soils and landslides.
- Many facilities were designed and constructed before the seismic design standards that reflect the current state of knowledge of regional seismicity were established.

THE EXISTING STATE

If it were to occur today, a Cascadia subduction zone earthquake would result in catastrophic impacts to the information and communications systems throughout western Oregon:

The Oregon coast would most likely experience strong ground shaking for over three minutes. Facilities within the tsunami inundation zones would be extensively damaged; in many cases, they would not be repairable. Facilities outside of the tsunami zone would be heavily damaged, disrupting current levels of service for periods measured in months. Cabling that runs through conduits supported on or in transportation bridges is likely to be damaged or severed completely when the bridges fail.

The Coast Range would experience strong to moderate ground shaking. Well-engineered structures may perform well, but older structures are likely to fail. Major impacts to the systems in the Coast Range include the high potential for landslides and the failure of bridges that support cables across geological features.

The Willamette Valley would experience moderate ground shaking. Well-engineered structures may perform well, but many older structures would likely fail, including central offices and buildings supporting antennas. One of the major impacts in the central valley, especially in the Portland Metro area, would be from liquefaction: extensive alluvial and fill deposits along rivers would lose strength, lose bearing capacity, and move towards riverbanks. Liquefaction could adversely impact buried utilities as well as antenna towers and buildings.



Figure 7.1: San Francisco – Oakland Bay Bridge after the 1989 Loma Prieta earthquake. An example of bridge failures that could impact utility conduits supported by or integrated into the bridge. Source: U.S. Department of Transportation. (Source: USGS website http://earthquake.usgs.gov/earthquakes/states/events/1989_10_18.php)

THE SYSTEM'S COMPONENTS

The Information and Communication Technology Task Group focused on wireless and wired communications and information systems that provide services to businesses, municipalities, and individuals. For the purpose of this resilience plan, system components include:

- **Central Offices.** A switching unit, installed in a telephone system serving the general public, having the necessary equipment and operating arrangements for terminating and interconnecting lines and trunks (McGraw-Hill, 2003). Central offices include the following types:
 - *Tandem office:* A telephone office that makes connections between local offices in an area where there is such a high density of local offices that it would be uneconomical to make direct connections between them (McGraw-Hill, 2003).
 - *Local office:* A telephone central office, which terminates subscriber lines and makes connections with other central offices, usually equipped to serve 10,000 main telephones of its immediate community (McGraw-Hill, 2003).
 - *End office:* A telephone central office that connects directly to the customer (Answers.com).
- **Remote Terminals.** A remote terminal is generally any type of switching or routing equipment that is located outside of the traditional telephone central office. Most are linked by fiber optic cable either directly to the central office or to a SONET (Synchronous Optical Network). Some older remote terminals are linked by T1s back to the central office over copper pairs.



Figure 7.2: The overhead lighting fixtures in a Central Office failed during an earthquake. Note the equipment in the background was supported by “jiffy poles” after the earthquake. Mexico City earthquake, 1985. (Source: Alex Tang)



Figure 7.3: Overloaded cable rack failed in relatively minor (M=5.8), Whittier Narrows earthquake, California, 1987. (Source: Alex Tang)



Figure 7.4: Telecom equipment and HVAC ducting failure. It is hard to tell which was the main cause of failure; it has several combinations, inadequate anchoring, un-braced duct supports, etc. Mexico City earthquake, 1985. (Source: Alex Tang)

- **Internet Exchange Points (IX or IXP).** A physical infrastructure through which Internet service providers (ISPs) exchange Internet traffic between their networks (autonomous systems). At these exchange points, major carriers accept traffic from each other and agree to carry one another's packets to their downstream destination points without charge. (Answers.com)
- **Submarine Cable Landings** (Answers.com)
 - *Submarine cable landing station:* This may or may not be required, depending on whether, for example, the submarine cable requires power to power submarine repeaters or amplifiers.
 - *Submarine cable termination station:* This is the point at which the submarine cable connects into the land-based infrastructure or network. A cable termination station may be the same facility as the cable landing station, or it may be many miles away.
- **Antennas.** These may be:
 - Mounted on buildings owned by the communications provider or on leased space on another building.
 - Tower mounted.
 - Satellite antennas (for system up/down links and not the satellite service of an end user).
 - Transmitter antennas for broadcast radio and TV.

- **Cables.** These may be:
 - Underground.
 - Inducted, conduit, buried plant (underground cable vaults).
 - Buried.
 - Aerial cable (overhead/above ground).
- **Outside Plants.** Examples include:
 - Splice cases.
 - Repeaters (that may require power).

Resilience Goal, Objectives, and Scope

Goal

The goal of this plan is to provide recommendations that, if implemented, would ensure that within 50 years the information and communication systems in the state of Oregon are made resilient against a magnitude 9.0 Cascadia subduction earthquake and tsunami.

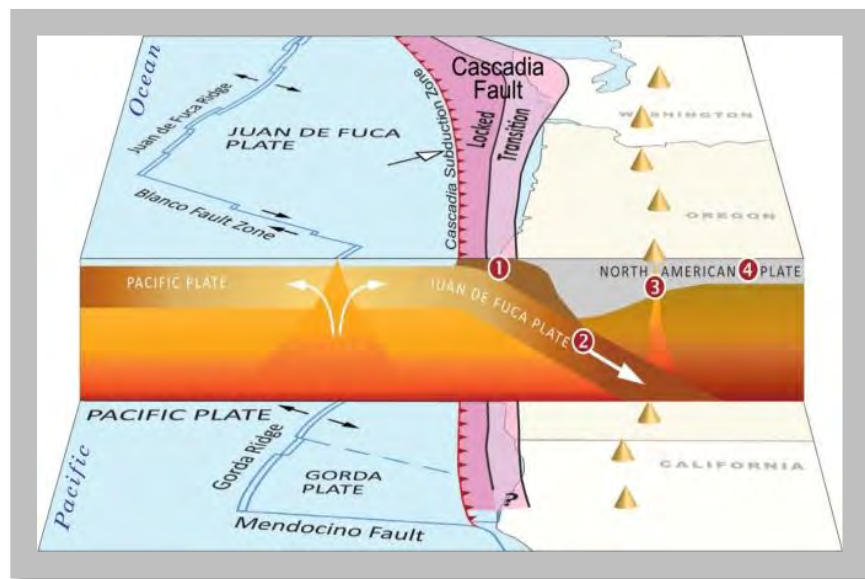

Figure 7.5: Cascadia seismic source is Oregon's most threatening fault and can produce a magnitude 9 earthquake and accompanying coastal tsunami waves.
(Source: DOGAMI)

The resilience goal for the information and communication systems is to provide for immediate emergency communications followed by phased restoration, within specified time periods, for various areas of the state. In order to establish resilience goals, the information and communication systems were assessed in four geographical areas:

- The tsunami inundation zone along the coast. This area was defined using Oregon Department of Geology and Mineral Resources (DOGAMI) maps.
- The part of the coast that is not susceptible to tsunami (from the Oregon coastline to the Coast Range summit).
- The valley (from the summit of the Coast Range to the summit of the Cascades).
- Eastern/Central Oregon.

Objectives and Targets

The task group viewed performance capability (for the purposes of recovery) across all information and telecommunications systems that support voice and data communications. The restoration objectives are based on the assumption that all other lifelines, such as roads and electricity, are functioning at a level that will support restoration of the information and communications infrastructure. In areas where the *customer* is not ready to accept service, then the service provider is not expected to meet these restoration timeframes. In the early phases of recovery, achieving these capabilities may require the use of temporary contingencies (such as mobile cellular towers) while more permanent repairs and installations are being done.

Establishing target timeframes for the tsunami inundation zone, beyond a minimal level of capability to support response, is not practical. A large amount of planning and prioritizing will need to be undertaken to identify which areas will be rebuilt first. These will then be the areas in which the information and communications systems will be re-established first.

Resilience targets for information and communications systems were established for three levels to assist in establishing priorities for resilience and restoration activities and projects:

- **Minimal.** A minimum level of service is restored, primarily for the use of emergency responders and repair crews and in support of critical health and human services (mass care). The estimated capability at this level is 20–30 percent. In the early phases of recovery, achieving these capabilities may require the use of temporary contingencies (such as mobile cellular towers) while more permanent repairs and installations are being done.
- **Functional.** Although service is not yet restored to full pre-event capacity, it is sufficient to get the economy moving again (such as for business uses, including credit card transactions and banking). Limits may be placed on uses that take up a lot of capacity, such as streaming video. The estimated capability at this level is 50–60 percent.
- **Operational.** Restoration is up to at least 90 percent of capacity. A full level of service has been restored and is sufficient to allow people to use the system for non-essential activities, such as entertainment. The estimated capability at this level is 80–90 percent.

The attached table (see Figure 7.16) reflects the target capabilities for each zone across all information and communications systems. This approach permits greater flexibility in how the systems are

recovered, which may change with the continuous changes in technology (that is, the systems may become less dependent on large towers).

WHAT DOES BEING RESILIENT MEAN

To understand what resilience means in the context of information and communication technology, the task group referred first to the definition of resilience that was adopted for the resilience report as a whole: “Oregon citizens will not only be protected from life-threatening physical harm, but...because of risk reduction measures and pre-disaster planning, communities will recover more quickly and with less continuing vulnerability following a Cascadia subduction earthquake and tsunami.” The task group then looked at Oregon’s position on the *resilience triangle* and at the characteristics of resilient systems.

The Resilience Triangle

The basic principle of the resilience triangle is that the smaller the triangle, the higher the resilience. Higher resilience requires minimal reductions in critical lifeline services after a disaster, speedy recovery of those services, and an overall improved service level as a result of rebuilding damaged systems and implementing better systems. The resilience triangle diagram indicates that Chile and Japan have high levels of earthquake resilience—this reflects Chile’s performance after a magnitude 8.8 earthquake in 2010 (ASCE TCLEE, 2010) and Japan’s performance after a magnitude 9.0 earthquake in 2011 (Nojima, 2012) (notwithstanding Japan’s nuclear energy issues). At the current stage, Oregon’s infrastructure has low resilience and is expected to have significant loss of sector services and a slow recovery time.



Figure 7.6: Resilience Triangle (Wang, Bartlett, and Miles, 2012)

Characteristics of Resilient Systems

Based on research conducted after disasters around the world, some basic system characteristics have been identified that enable communications and information technology systems to be resilient.

Resilient systems tend to be:

- Decentralized.
- Meshed or integrated.

- Built to withstand the potential hazard, but without an expectation of 100-percent survivability.
- Capable of recovering (within two to four weeks of the event) whichever components of the system did not survive.
- Able to handle a surge in demand through system performance levels or implementation of controls.
- Upgraded by means of continuous hardening of vulnerable components within the system.

Plan Development

PLANNING CONSIDERATIONS

The task group took into consideration the following items during the development of the plan:

- Resilience planning needs to address the capacity of the system. In major events, landline and wireless telecommunications can be quickly overwhelmed by demand, even if they are 100-percent operational.
- Wireless communications technology is evolving rapidly and the technology that influences planning decisions and recommendations today may not be in existence 25 to 50 years from now.
- Hardline and wireless communication systems typically install their new technology into existing infrastructure (i.e., buildings, power poles, towers, vaults, and conduits). This means that 21st century technology may be housed in, or mounted on, a structure built in the early to mid-1900s.
- The resilience plan should consider business continuity recommendations for the companies that provide communication, information, or telecommunications services and systems, especially to customers who perform critical services and other functions related to life safety.
- Wireless communication systems include antennas installed on leased space on buildings that the communications providers do not own or control. The locations of the buildings, relative to the coverage and demand requirements, are the key factors in the placement decisions, not the resilience of the structures or their location outside of the known hazard areas.
- Restoration of aerial (overhead) telecommunication wires is secondary to the restoration of aerial (overhead) power lines.
- Lifeline interdependence is a key factor that governs the final resilience plan.



Figure 7.7: Cellular Base Station tower failure. This site is installed on the roof of an apartment building, which is not designed for critical infrastructure facility. Pisco, Peru earthquake, 2007. (Source: Alex Tang)

INTERDEPENDENCIES

Information and communications systems have several connections with other resilience planning task groups that directly impact their resilience and ability to recover:

- **Buildings**
 - Structural integrity of buildings housing system components as well as business services and call centers.
 - Structural integrity of buildings with wireless system antennas mounted on them.
- **Transportation**
 - Transportation routes typically include utility easements for overhead and underground information and communication systems.
 - Access to system facilities after an earthquake is essential for restoration as well as for maintaining emergency power systems.
 - Bridges convey utilities, as well as vehicles, over geological barriers.

- **Utilities**
 - Because information and communications systems share common easements with other utilities, coordination is required to achieve restoration.
 - Overhead utilities share common infrastructure (such as poles); coordination will therefore be required to achieve restoration.
 - Information and communications systems are dependent on other utilities to provide and restore their services (such as electricity).
- **Energy**
 - Electrical power is needed to run the equipment.
 - Fuel is needed for emergency generators and to supply the vehicles used for emergency response and repair work.
- **Business Resilience.** Information and communication service providers need to be resilient so that they are able to restore service quickly to their customers.



Figure 7.8: Circuit Boards pulled out and fan to get some air cooling due to failure of the air conditioning unit. Fortunately, the site had power and they could open windows to allow cool air to come in. Izmit (Kocaeli) earthquake, Turkey, 1999. (Source: Alex Tang)

Assessment of Performance

GENERAL ASSESSMENT

A complete, detailed assessment of all the telecommunications and information systems in Oregon is not possible without detailed systems data from all the service providers. From a system-wide

perspective, however, a general assessment can be made based on information that is generally available. This information includes:

- Design standards and age of structures relative to the expected performances of buildings, towers, and other structures in the tsunami inundation zone.
- Design standards and age of structures relative to the expected performances of buildings, towers, and other structures and taking into account the relative levels of shaking expected at varying distances from the subduction zone.
- Expected performances of bridges that are an integral part of the hardwire infrastructure.
- Potential impacts that landslides and liquefaction will have on the towers, poles, buried utilities, buildings, and bridges that convey cable across rivers and ravines.
- The capabilities analyses of other sectors, particularly the electrical utilities, which have similarities with portions of the information and communications systems and are an integral part of maintaining and re-establishing information and communications capabilities.
- Capabilities and capacity—including resources (material and technical resources), mutual aid programs, spares, tools, and equipment—after a major disaster.



Figure 7.9: Inadequate anchorage and poor overhead bracing details resulted in equipment toppling. Mexico City earthquake, 1985. (Source: Alex Tang)

It should also be noted that even if a structure (building or tower) were to survive an event, damage to improperly secured equipment can result in the loss of operational capability.

Depending on the general availability of the equipment (off-the-shelf versus specifically designed and manufactured), it could take longer to replace or repair the equipment than it does to repair or replace the building.

ASSESSMENT BY ZONE

Using the general assessment criteria, the task group did an assessment of performance capabilities for each of the four geographic areas (see also the attached figure in Figure 7.16):

Zone 1: Coast—Tsunami Zone

All communications and information technology infrastructure within the tsunami inundation zone will sustain major damage or be destroyed. The ability to operate any equipment that survives both the earthquake and the tsunami will depend on the availability of electrical power and whether crews are able to access the equipment in order to perform maintenance and repairs.

- **Buildings.** All buildings in the inundation area will be destroyed or heavily damaged.
 - Few buildings are built to current seismic code and even fewer are built to the critical facility level (which is designed to increase the chances that the structure will be usable after the earthquake).
 - Those structures not destroyed by the earthquake will be inundated by the tsunami waves.
- **Equipment.** Equipment in buildings.
 - Existing standards for communications and information technology do not appear to address the protection of equipment from damage during large seismic events.
 - Improperly secured equipment can be damaged or destroyed even if the structure that houses it survives both the seismic shaking and the tsunami waves.
- **Towers.** Antenna towers in the inundation zone have the same probabilities of being damaged and destroyed as the buildings.
 - A number of the towers and antennas are located on existing buildings and will be only as reliable as the buildings they are on.
 - Even if towers are free standing and reinforced to withstand the shaking and the tsunami waves, the equipment on the towers must be positioned above the inundation height of the tsunami wave and properly secured to avoid damage from the shaking.
 - Free standing towers without properly constructed foundations could fail due to liquefaction.
- **Aerial Cables.** Overhead lines that survive the scenario earthquake will be destroyed by the tsunami wave (with the possible exception of those on the outer most edges of the inundation area).
 - Cross arms, connectors, and insulators that are designed to break away in high winds to reduce the potential damage to the utility poles could also give way during the seismic event.
 - Liquefaction can cause utility poles to lean or topple.

- Debris in the tsunami inundation waves will have significant impacts on utility poles and lines.
- **Underground Lines.** Depending on the amount of liquefaction and shearing forces, the earthquake could be just as devastating to the underground utilities as to the overhead lines. While the tsunami wave may have little direct impact on buried lines, the failure of utility vaults, salt water inundation of underground conduits, and loss of terminal posts will be just as disruptive as the physical loss of the lines.
 - Breaks in the underground lines are hard to locate unless there is some obviously related disturbance of the ground or activity in the vicinity of the break.

Zone 2: Coast—Earthquake-Only Zone

Only structures built to withstand the expected level of shaking are likely to be usable after the earthquake. Even these structures, however, will have limited functional capability if they are without utilities and there is no way to access them.



Figure 7.10: Cell site collapsed with the commercial building collapse. Chi Chi earthquake, Taiwan, 1999. (Source: Alex Tang)

- **Buildings.**
 - Few buildings are built to current seismic code and even fewer are built to the critical facility level (which is designed to increase the chances that the structure will be usable after the earthquake).
 - The tsunami, failure of bridges, and landslides can isolate facilities that survive the shaking, further limiting their use.

- **Equipment.** Equipment that is not properly secured for the expected level of shaking or protected from cascading events (such as the sprinkler system going off) could be damaged and require an extended period of time for repair or replacement.
 - Existing standards for communications and information technology do not appear to address the protection of equipment from damage during large seismic events.
 - Improperly secured equipment can be damaged or destroyed even if the structure that houses it survives.
- **Towers.** Antenna towers are likely to be damaged both by shaking during the scenario earthquake and by liquefaction. Towers located in the Coast Range are also prone to possible impacts from landslides.
 - Even if towers are free standing and reinforced to withstand the shaking, the equipment on the towers must be properly secured to avoid damage from the shaking.
 - Surviving towers will not be usable unless power and other utilities are available.
 - Connectivity between towers or between towers and landline networks may be disrupted as microwave dishes move, underground cables are severed by landslides, and utility lines break when the bridges they span fail.
- **Aerial Cables.** Overhead lines will be prone to failure during the expected shaking of the scenario event due to the lateral forces on the lines and poles as well as liquefaction and landslides.
 - Cross arms, connectors, and insulators that are designed to break away in high winds to reduce the potential damage to the utility poles could also give way during the seismic event.
 - Liquefaction can cause utility poles to lean or topple.
 - Landslides can damage or destroy utility poles located on steep slopes.
- **Underground Lines.** Depending on the amount of liquefaction and shearing forces, the earthquake can be just as devastating to the underground utilities as to the overhead lines.
 - Breaks in the underground lines are hard to locate unless there is some obviously related disturbance of the ground or activity in the vicinity of the break.
 - Underground lines can be severed by landslides and by the failure of the bridges that support them across geological features such as rivers and ravines.

Zone 3: Valley

Only structures built to withstand the expected levels of shaking are likely to be usable after the earthquake. Even these structures, however, will have limited functional capability if they are without utilities and there is no way to access them.

- **Buildings.** While the expected shaking in the valley during this scenario earthquake will not be as great as on the coast, a significant number of buildings in the valley were built prior to current seismic code.
 - Very few buildings associated with information and communications technology have been built to the critical facility level (which is designed to increase the chances that the structure will be usable after the earthquake).
 - While the structural components of a building may survive the earthquake, failure of nonstructural components, including windows, HVAC systems, lighting, and plumbing, can render the facility unusable for an extended period of time.
- **Equipment.** Equipment that is not properly secured for the expected level of shaking or protected from cascading events (such as the sprinkler system going off) could be damaged and require an extended period of time for repair or replacement.
 - Existing standards for communications and information technology do not appear to address the protection of equipment from damage during large seismic events.
 - Improperly secured equipment can be damaged or destroyed even if the structure that houses it survives.

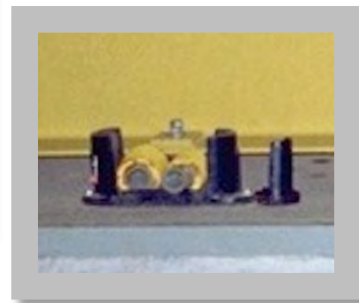
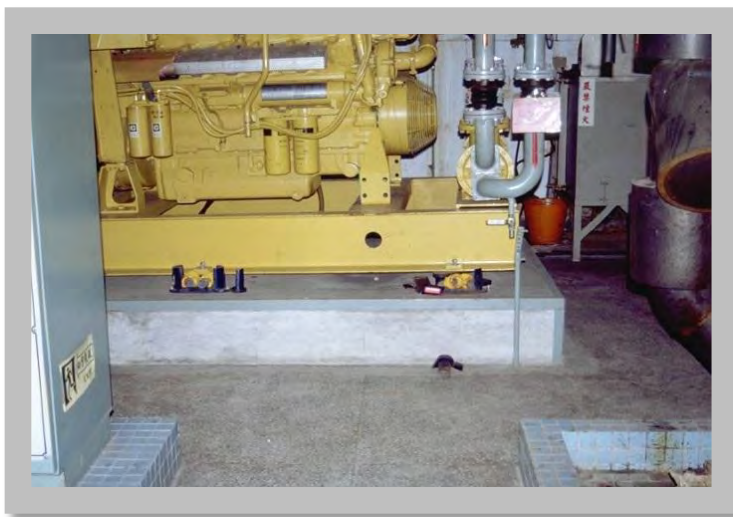

Figure 7.11a and 7.11b: Close-up of the two vibration isolation units. The cause of the failure was due to lack of details to limit the generator displacement during the strong shaking.

Figure 7.11: Backup generator failure - the vibration isolators of this unit all failed after the earthquake. Chi Chi earthquake, Taiwan, 1999. (Source: Alex Tang)

- **Towers.** Antenna towers may be damaged by the shaking during the scenario earthquake as well as by liquefaction. Towers located in the Coast Range and West Hills could also be damaged by landslides.

- A number of the towers and antennas are located on existing buildings and will be only as reliable as the buildings they are on.
- Even if towers are free standing and reinforced to withstand the shaking, the equipment on the towers will need to be properly secured to avoid damage from the shaking.
- Surviving towers will not be usable unless power and other utilities are available.
- Connectivity between towers or between towers and landline networks may be disrupted as microwave antennas move, underground cables are severed by landslides, and utility lines break when the bridges they span fail.
- **Aerial Cables.** While the damage is expected to be less severe in this zone than on the coast, overhead lines could fail during the expected shaking of the scenario event due both to the prolonged lateral forces on the lines and poles and to liquefaction and landslides.
 - Cross arms, connectors, and insulators that are designed to break away in high winds to reduce the potential damage to the utility poles could also give way during the seismic event.
 - Liquefaction can cause utility poles to lean or topple.
 - Landslides can damage or destroy utility poles located on steep slopes.
- **Underground Lines.** Depending on the amount of liquefaction and shearing forces, the earthquake can be just as devastating to the underground utilities as to the overhead lines.
 - Breaks in the underground lines are hard to locate unless there is some obviously related disturbance of the ground or activity in the vicinity of the break.
 - Underground lines can be severed by landslides and by the failure of the bridges that support them across geological features such as rivers and ravines.

Zone 4: Eastern Oregon

In this zone, capabilities will be more dependent on the availability of power than damage or physical loss of structures and equipment.

- **Buildings.** Older and poorly built structures (for example, unreinforced brick buildings) that are located in areas identified in the scenario earthquake as likely to sustain moderate and moderate-to-heavy damage will sustain damage and could partially collapse.
 - Very few buildings associated with information and communications technology have been built to the critical facility level (which is designed to increase the chances that the structure will be usable after the earthquake).
 - While the structural components of a building may survive the earthquake, failure of nonstructural components, including windows, HVAC systems, lighting, and plumbing, can render the facility unusable for an extended period of time.

- **Equipment.** Equipment that is not properly secured for the expected level of shaking or protected from cascading events (such as the sprinkler system going off) could be damaged and require an extended period of time to repair or replace.

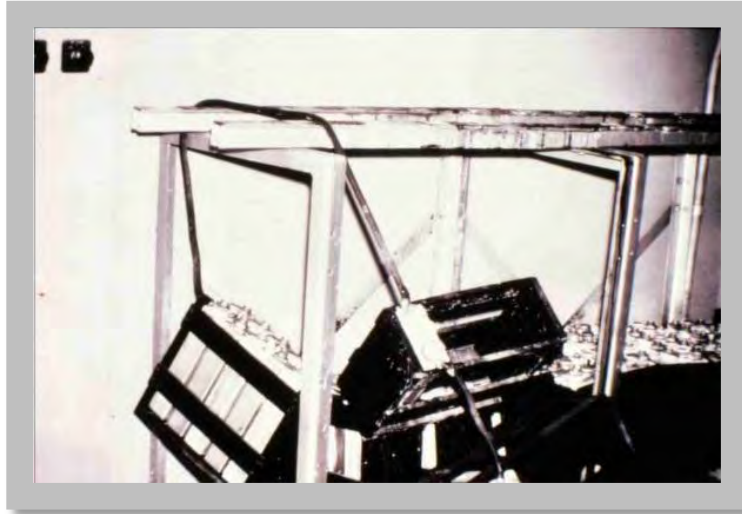

Figure 7.12: The battery rack is designed to resist lateral force with very light cross bracing. The batteries, however, were not secured on the rack and fell, resulting in reserve power failure San Fernando earthquake, California, 1971. (Source: Alex Tang)

- Existing standards for communications and information technology do not appear to address protection of equipment from damage during large seismic events.
- Improperly secured equipment can be damaged or destroyed even if the structure that houses it survives.
- **Towers.** Antenna towers may be damaged by the shaking during the scenario earthquake as well as by landslides if the towers are located on steep slopes.
 - A number of the towers and antennas are located on existing buildings and will be only as reliable as the building they are on.
 - Even if towers are free standing and reinforced to withstand the shaking, the equipment on the towers must be properly secured to avoid damage from the shaking.
 - Surviving towers will not be usable unless power and other utilities are available.
- **Aerial Cables.** Overhead lines could fail in areas that experience higher levels of shaking due both to the prolonged lateral forces on the lines and poles and to landslides that are triggered by the earthquake.
 - Cross arms, connectors, and insulators that are designed to break away in high winds to reduce the potential damage to the utility poles could also give way during the seismic event.

- Landslides can damage or destroy utility poles located on steep slopes.
- **Underground Lines.** Underground lines are likely to be the least impacted in this zone.
 - Breaks in the underground lines are hard to locate unless there is some obviously related disturbance of the ground or activity in the vicinity of the break.
 - Underground lines can be severed by landslides and by the failure of the bridges that support them across geological features such as rivers and ravines.

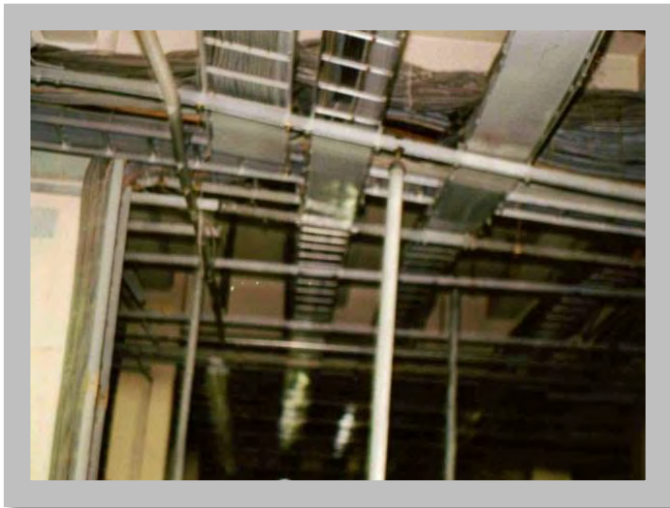
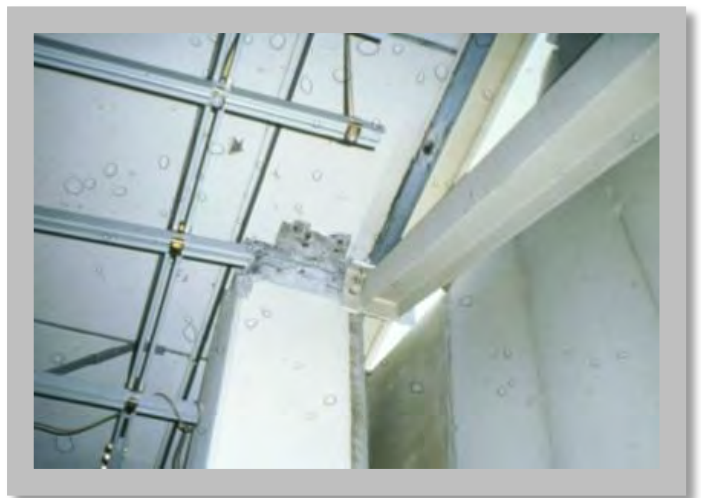

Figure 7.13: Super structure of cable racks failed due to lack of detailing and in many cases, overload. Whittier Narrow earthquake, California, 1987. (Source: Alex Tang)

Figure 7.14: Upgraded Central Office with bracings damaged, Northridge Earthquake, California, 1994. (Source: Alex Tang)



Target Timeframes for Recovery

Performance capability for recovery purposes is viewed across all information and telecommunications systems that support voice and data communications. The restoration objectives are based on the assumption that all other lifelines, such as roads and electricity, are functioning at a level that will support restoration of the information and communications infrastructure. In areas where the *customer* is not ready to accept service, the service provider is not expected to meet these restoration timeframes.



Figure 7.15 – Collection of damaged bracing beams removed from Central Office. Northridge earthquake, California, 1994. (Source: Alex Tang)

Establishing target timeframes for the tsunami inundation zone, beyond a minimal level of capability to support response, is not practical. A large amount of planning and prioritizing will need to be undertaken to identify which areas will be rebuilt first. These will then be the areas in which the information and communications systems will be re-established first.

KEY TO THE TABLE

Target Timeframe for recovery:

Operational: Restoration is up to 90% of capacity: A full level of service has been restored and is sufficient to allow people to use the system for non-essential activities (such as entertainment). 80%–90%

Functional: Although service is not yet restored to full pre-event capacity, it is sufficient to get the economy moving again (e.g. business uses for credit cards and banking). Limits may be placed on uses that take up a lot of capacity (such as streaming video). 50%–60%

Minimal¹: A minimum level of service is restored, primarily for the use of emergency responders, repair crews, and in support of critical health and human services (mass care). 20%–30%

Estimated time, under current conditions, for system-wide recovery to be at (or 90% of) pre-event capacity

G
Y
R
x

1. In the early phases of recovery, achieving these capabilities may require the use of temporary contingencies (such as mobile cellular towers) while more permanent repairs and installations are being done.

TARGET STATES OF RECOVERY:										
INFORMATION AND COMMUNICATIONS TECHNOLOGY SECTOR										
	 Event occurs	0–24 hours	1–3 days	3–7 days	1–2 weeks	1–3 months	3–6 months	6 months –1 year	1–3 years	3 + years
ZONE 1: COAST—TSUNAMI ZONE				R						
Buildings (includes central offices, internet exchange points, and cable landings)										
• Repair								x		
• Replace									x	
Equipment in Buildings and on Towers									x	
Towers									x	
Underground Lines									x	
Overhead Lines									x	
ZONE 2: COAST—EARTHQUAKE-ONLY ZONE			R		Y	G				

(To be continued on next page)

	Event occurs	0–24 hours	1–3 days	3–7 days	1–2 weeks	1–3 months	3–6 months	6 months –1 year	1–3 years	3+ years
Buildings										
• Repair								x		
• Replace									x	
Equipment in Buildings								x		
Towers								x		
Underground Lines							x			
Overhead Lines							x			
ZONE 3: VALLEY		R		Y	G					
Buildings										
• Repair								x		
• Replace									x	
Equipment in Buildings						x				
Towers						x				
Underground Lines						x				
Overhead Lines					x					
ZONE 4: EASTERN OREGON	R		Y	G						
Buildings										
• Repair						x				
• Replace								x		
Equipment in Buildings					x					
Towers				x						
Underground Lines				x						
Overhead Lines				x						
	Event occurs	0–24 hours	1–3 days	3–7 days	1–2 weeks	1–3 months	3–6 months	6 months–1 year	1–3 years	3+ years

Figure 7.16– Target States of Recovery: Information and Communications Technology Sector

Resilience Gap Analysis Summary

The table in Figure 7.16 shows significant difference between the current capabilities of the system and the target capabilities, especially at the coast and in the valley. As the threat of a magnitude 9.0 subduction zone earthquake is recognized and new design and building standards are adopted and implemented in response to it, new construction of information and communications infrastructure will be more likely to achieve the resilience targets. Without changes in policy and other incentives,

however, we do not foresee any significant changes in the performance capabilities of existing system components.

- Companies in this sector should institutionalize long-term seismic mitigation programs and should work with the appropriate agencies and stakeholders to achieve timely and effective mitigation to ensure that their facilities are resilient and their operations reliable.
 - Require that central offices, Internet exchanges, remote terminals, and submarine cable landings be built or retrofitted to meet the *critical facility* standard.
 - Include within site development and zoning codes the requirement that information and communications technology structures be built to withstand the potential impacts of a scenario earthquake and tsunami. This should include:
 - Limitations on building in tsunami inundation areas.
 - Limitations on construction of antenna towers on buildings that do not meet the critical facility standard.
 - Accounting for potential liquefaction and slope instability when constructing towers, buildings, underground utilities, and overhead lines.
 - Adopt clear, statewide uniform standards, like the NEBS (Network Equipment-Building System), for the adequate performance and bracing of information and telecommunications equipment that must withstand the scenario event, and establish a mechanism for reliable enforcement.
 - Establish a hardened backbone for information and telecommunications systems in conjunction with the ODOT's hardening of primary transportation routes.
- Companies in this sector should work with the state of Oregon to build Oregon's seismic resilience to a Cascadia earthquake.
 - Adopt pro-active practices and a risk management approach to help achieve seismic resilience.
 - Encourage a culture of awareness and preparedness in relation to the seismic vulnerability of the energy sector, and stress the need to conduct long-range energy planning.
- Create an ongoing marketing and education program for Oregon to craft the resilience message for the public. This is to bring about a cultural shift toward preparing for the catastrophic Cascadia subduction zone earthquake and to learn the cost of becoming prepared.
 - Create a public information officer position (for the state) and assign to it responsibility for this marketing and education program.
 - Involve all types of media in promoting this new culture of preparedness.
- Recommend the state and municipalities should include system resilience criteria in their requests for proposals when contracting for telecommunications and information services.



Recommendations

As demonstrated in Chile (ASCE TCLEE, 2010), resilience can be achieved within a 50-year period without unrealistic amounts of new investment. Companies in this sector should be encouraged to institutionalize long-term seismic mitigation programs and to work with the appropriate agencies and stakeholders to achieve timely and effective mitigation to ensure that their facilities are resilient and their operations reliable. Towards that end, the task group proposed the following recommendations for consideration:

- ▶ **Information and communications companies should conduct seismic vulnerability assessments (SVA) on all of their infrastructure facilities, and they should work with the appropriate agencies and stakeholders to achieve timely completion of the assessments to understand existing vulnerabilities.**
 - The Public Utility Commission of Oregon (OPUC) is the proper oversight authority for all telecommunications utilities that are subject to the OPUC’s Oregon Administrative Rules.
 - The OPUC may need to define the criteria for seismic vulnerability assessments.
 - The OPUC should review the results of the seismic vulnerability assessments and the systems’ resilience to other natural disasters (within the scope of their mission).
 - The implementation of this recommendation could also involve the participation of the Oregon Department of Geology and Mineral Industries (DOGAMI), the Building Codes Division, and the Oregon Seismic Safety Policy Advisory Commission (OSSPAC).
- ▶ **Provide liability waiver language in statute for vulnerabilities identified in the seismic vulnerability assessments that are above operators’ current normal operations.**
- ▶ **Companies in this sector should institutionalize long-term seismic mitigation programs.**
- ▶ **Utilize the Oregon Office of Emergency Management’s public-private sector position to help ensure coordinated planning, information sharing, and interoperability among critical organizations and agencies. The position will also ensure that work being performed by this entity and its partners helps provide public education and outreach to local, county, and state agencies and organizations.**
- ▶ **The state of Oregon should provide statutory authority for a prescriptive waiver of routine permitting requirements and processes for the design, construction, and restoration of communication and information infrastructure, if it is determined that the waiver is in the public interest and is necessary to address an actual or impending emergency (and subsequent actions) caused by a natural or manmade disaster.**

References

1. McGraw-Hill (2003). *McGraw-Hill Dictionary of Scientific and Technical Terms*, 6th edition. New York/Chicago/San Francisco: McGraw-Hill Companies.
2. Nojima, N. (2012). “Restorations and System Interactions of Lifelines in the Great East Japan Earthquake Disaster, 2011,” *Proceedings of the International Symposium on Engineering Lessons Learned from the 2011 Great East Japan Earthquake*, March 1-4, Tokyo, Japan.
3. ASCE TCLEE (2011). *Preliminary Report on the 27 February 2010 Mw 8.8 Offshore Maule, Chile Earthquake*. Technical Council on Lifeline Earthquake Engineering (TCLEE), American Society of Civil Engineers.
4. Wang, Y., Bartlett, S.F., and Miles, S.B. (2012). *Earthquake Risk Study for Oregon’s Critical Energy Infrastructure Hub*. Final Report to Oregon Department of Energy & Oregon Public Utility Commission. Oregon Department of Geology and Mineral Industries, August. The full EAP report is accessible at <http://www.oregon.gov/puc/docs/DOGAMICEIHubreport-8-1-12-R1.pdf>.

8. Water and Wastewater Systems

Introduction

Oregon's water and wastewater systems are especially vulnerable to damage resulting from a Cascadia subduction zone earthquake. Some of the inherent seismic vulnerabilities of water and wastewater systems include:

- The systems tend to be large and complex, consisting of a combination of pipeline networks serving large areas and concentrated facilities (such as treatment plants and pump stations), with numerous potential points of failure.
- The systems are highly dependent on other resources—such as power, transportation, chemicals, and skilled staff—to remain operational and to complete needed repairs.
- The systems are financially dependent on consistent revenue streams to fund ongoing operations, maintenance, and debt service obligations.
- Essential facilities, such as intakes, treatment plants, pump stations, and outfalls, are often located near rivers and lakes and are vulnerable to damage from liquefaction of alluvial soils.
- Many critical facilities, such as reservoirs, pump stations, and treatment plants, were designed and constructed before the adoption of seismic design standards that reflect the current state of knowledge of regional seismicity.
- Pipeline networks include extensive use of non-ductile (inflexible) materials, such as concrete and cast-iron pipe, which tend to fail during strong ground motion.
- Pipelines are especially vulnerable to failure from permanent ground deformation (resulting from liquefaction and landslides), because the deformation causes *push-on* pipe joints to separate.
- Water and sewer pipelines tend to be prone to failure at connections to aboveground structures, such as reservoirs, treatment plants, pump stations, and service connections to homes.
- Water from leaks and breaks in water pipelines and private plumbing systems will cause collateral damage, drain available water storage, and contribute to loss of water supply and pressure, which will in turn result in a loss of fire protection capability.
- The performance of gravity sanitation and storm sewers depends on accurate grades and slopes, which are disrupted by ground displacement resulting from liquefaction.
- Failures of storm sewers can contribute to localized flooding during even minor rain events, resulting in collateral damage.

THE EXISTING STATE

If it were to occur today, a Cascadia subduction zone earthquake would result in catastrophic impacts to existing water and wastewater systems throughout western Oregon. The Oregon coast would most likely experience strong ground shaking for over three minutes. Facilities within the tsunami inundation zone would be extensively damaged; in many cases, these facilities would not be repairable. Facilities outside of the tsunami zone would be heavily damaged, with total loss of water and wastewater services for periods measured in months and, in some cases, years.

The Willamette Valley would experience moderate ground shaking. Well-engineered structures may perform well, but many older structures would likely fail, including treatment facilities, reservoirs, and pump stations. One of the major impacts to large population centers would be from liquefaction: extensive alluvial and fill deposits along rivers would lose strength, lose bearing capacity, and move towards riverbanks. Old cast iron water pipelines buried in the liquefied soil would snap, and modern pipelines constructed of ductile iron and PVC would likely pull apart at joints, resulting in a total loss of water pressure throughout communities. Large drainage structures along riverbanks in liquefiable areas would likely move, severing connecting piping and rendering the structures useless. Examples of the type of damage likely to occur are illustrated in Figures 8.1–8.7.



Figure 8.1: Tank piping separated, Northridge earthquake, California, 1994 (Source: Los Angeles Department of Water and Power)

Figure 8.2: Tank buckling, Northridge earthquake, California, 1994 (Source: Photo by Don Ballantyne)



Figure 8.3: Wire wrapped concrete tank burst in Purisima Hills, Loma Prieta earthquake, California, 1989 (Source: Photo by Don Ballantyne)

Figure 8.4: Welded steel pipe failed in compression, San Fernando (Sylmar) earthquake, California, 1971 (Source: Photo Source Unknown)





Figure 8.5: Pipelines separated, Great Hanshin earthquake, Kobe, Japan, 1995 (Source: Kobe Water Department)

Figure 8.6: Water well and treatment facility in tsunami inundation area, Tohoku earthquake, Japan, 2011 (Source: Photo Source Unknown)

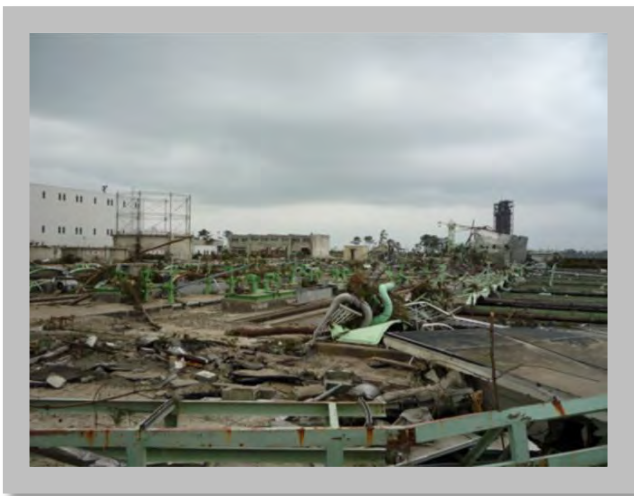

Figure 8.7: Minami Gamou Wastewater Treatment Plant impacted by tsunamis, Tohoku earthquake, Sendai, Japan, 2011 (Source: Photo by Don Ballantyne)

Water for Fire Suppression

In the current state of readiness, existing water systems would experience extensive leaks and breaks in water supply pipelines. These leaks, coupled with loss of water supply facilities, such as treatment plants and pump stations, would drain the water systems. This loss of volume and pressure would critically limit the availability of water supply for conventional urban firefighting: fire hydrants would be rendered useless, and many fire sprinkler systems would be inoperable (even those sprinkler systems that remain intact).

Urban and suburban firefighting strategies would resemble those commonly used in rural areas: water for fire suppression would only be available from lakes, rivers, streams, swimming pools, and any surviving local water storage reservoirs. Fire engines would draft from these sites and rely on tankers to move water to fires. The combination of transportation infrastructure damage, compromised emergency communications systems, and high emergency incident volumes, would limit the ability of fire departments to respond to individual incidents. Fire departments would have to identify, assess, and prioritize responses and would focus on life safety and containment rather than trying to extinguish every fire. Photos of previous earthquake-related fire events are shown in Figures 8.8–8.10.



Figure 8.8: Fire in the Marina District required a fireboat to pump water for suppression, Loma Prieta earthquake, San Francisco, 1989. Over 100 pipeline failures occurred within the immediate area. (Source: Photo Source Unknown)

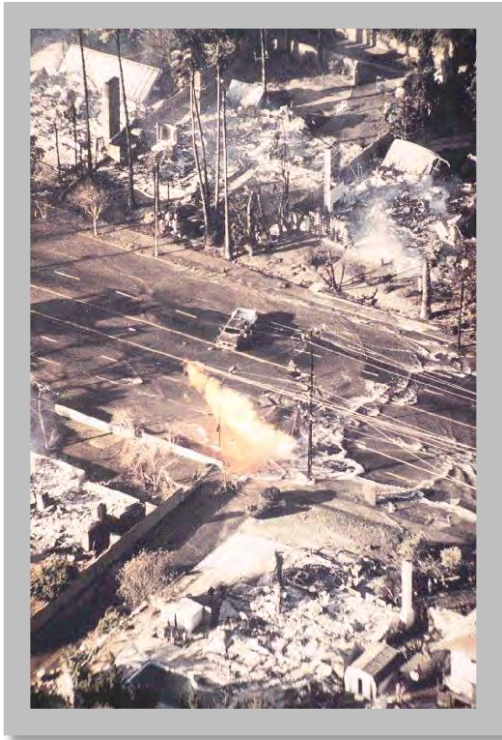
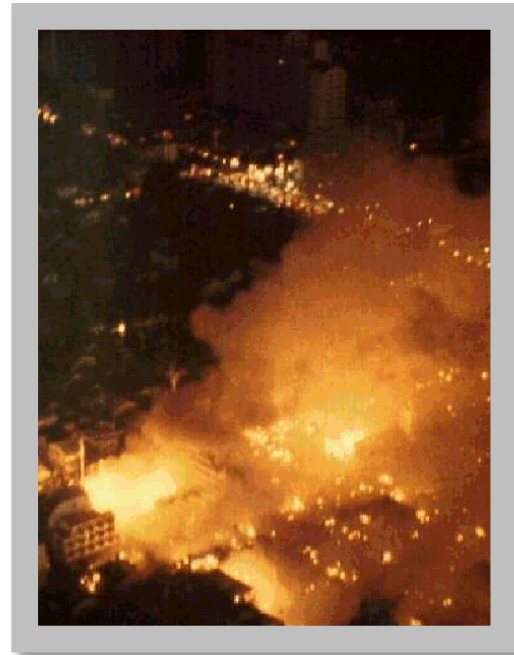

Figure 8.9: Fire from a gas line explosion on Balboa Boulevard, Northridge earthquake, California, 1994
(Source: Photo Source Unknown)

Figure 8.10: Conflagration resulting from water system failures, Great Hanshin earthquake, Kobe, Japan, 1995
(Source: Photo Source Unknown)



Potable Water Supplies

In the current state of readiness, water utilities would be unable to provide water from the existing distribution system. Communities would rely on emergency supplies for the first one to two weeks, depending on location and on the condition of transportation infrastructure. Some areas would have *no* water supplies during that time. Water for healthcare facilities such as hospitals would be severely restricted. Emergency water supplies would meet only subsistence needs (for example, direct consumption and very limited bathing). For the first one to two months, water would be delivered via tankers to smaller tanks and bladders distributed throughout the community. People would wait in line to fill their containers and then carry the water home. Some water would come from portable water

treatment units provided by the military, equipment suppliers, and foreign countries; however, the quantity of water supplied from those resources would be small compared to demands. Photos of water distribution following other earthquakes are presented in Figures 8.11–8.13.



*Figure 8.11: Water distributed by tank truck, Northridge earthquake, Los Angeles, 1994
(Source: Photo by Don Ballantyne)*

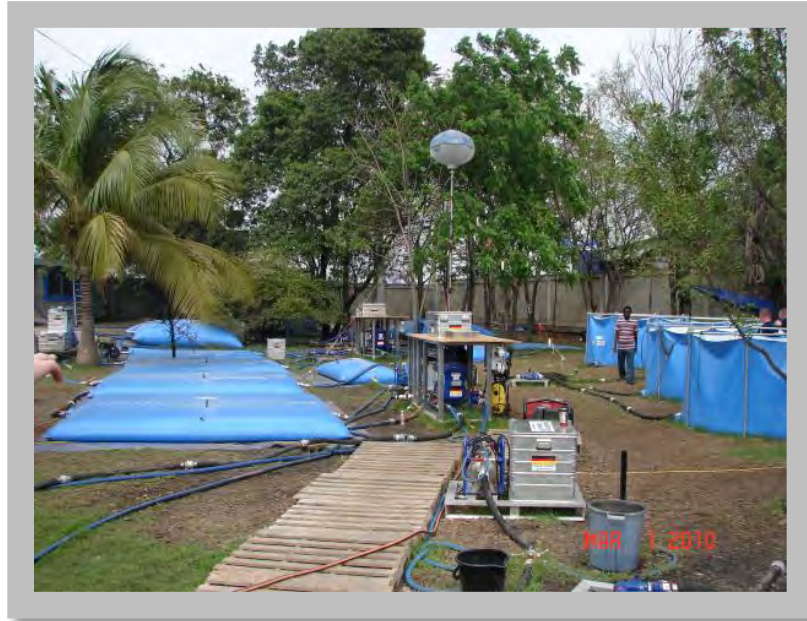

*Figure 8.12: Temporary water treatment plant, Haiti earthquake, 2010
(Source: Photo by Don Ballantyne)*



*Figure 8.13: People waiting for water, Haiti earthquake, Port Au Prince, 2010
(Source: Photo by Don Ballantyne)*

Manufacturing facilities, hotels, restaurants, and even office buildings that depend on water would be closed. Within several weeks of the event, a few restaurants might reopen using paper plates, but in many locations, water for use in bathrooms, dish washing, and laundry could be delayed for months.

A month following the earthquake, water supplies, treatment facilities, and transmission systems would begin to come online and replace the portable treatment units. People would still need to carry water from distribution points to their homes and businesses. In the hardest hit areas—the Oregon coast and areas with liquefiable soils—it may take six months to a year or more for water services to be restored to individual homes and businesses.

Wastewater Facilities

Sewers and pump stations in liquefiable areas would be heavily damaged. Large pump stations along rivers would likely settle or tilt, shearing off connecting piping. Sewage would overflow into nearby bodies of water. In areas distant from water bodies, raw sewage would likely flow into gutters and ditches, making its way through the surface water drainage system. In many cases, sewage would likely back up into homes and businesses. Because there would be little water available to flush toilets, sewage flows would be small, except in areas served with combined sewers. In many cases, people would attempt to use toilets in their houses and flush with a bucket of water. Because there would not be enough water to move the solids effectively downstream, sewers would plug within the first few weeks.

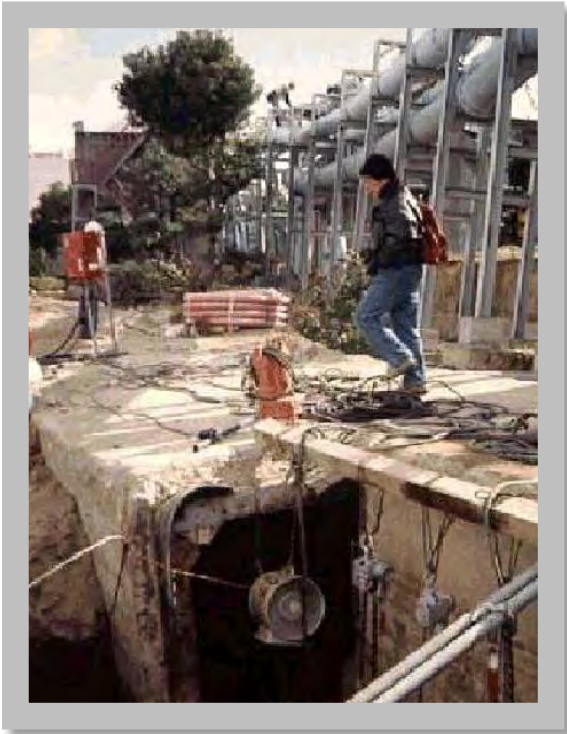

*Figure 8.14: Damage from liquefaction/lateral spreading at Higashinada WWTP, Kobe, Japan, 1995.
(Source: Photo by Don Ballantyne)*



*Figure 8.15:
Damage from
liquefaction/lateral
spreading at
Higashinada
WWTP, Kobe,
Japan, 1995
(Source: Photo by
Don Ballantyne)*



*Figure 8.16: Sewer line that floated to the surface as a result of liquefaction, Dagupan, Philippines, 1990.
(Source: Photo by Don Ballantyne)*

In areas where the potable water system is still functioning, wastewater would be generated and discharged into rivers, streams, and lakes. Rivers would quickly become polluted with wastewater solids, as they were prior to the advent of treatment plants in the first half of the twentieth century. Water treatment plants that draw raw water from contaminated rivers would likely become compromised or would require extraordinary measures, such as operating at very low treatment rates and high dosing rates for treatment chemicals.

In many locations it would take a year before the sewage collections system is functioning and three years before major trunk lines and treatment plants are fully restored to their pre-earthquake functionality. In these situations, people would likely turn to using chemical toilets, available in limited numbers, and latrines.

Water and Wastewater Resilience Planning

Re-establishing water and wastewater service will be a crucial element in the overall recovery of communities after a Cascadia subduction zone earthquake. Water for fire suppression, first aid, emergency response, and community use, as well as water for normal health and hygiene, will be required soon after the event. Functioning wastewater systems that help protect the community from sewage contamination, health hazards, and disease outbreaks will be essential.

The time required to re-establish water and wastewater services will depend largely on the pre-event condition of the systems, the actual intensity and duration of the event, the size and complexity of the systems, and the availability of staff and the financial and material resources needed to complete

repairs. In addition, damage to other infrastructure, such as the transportation, communications, fuel, and power systems, may control the time required to restore water and wastewater infrastructure.

The Oregon Resilience Plan’s Water and Wastewater Task Group included participation by various industry professionals, including representatives from academia, municipalities, special districts, and consultants. Communities participating in the planning effort are summarized in Figure 8.17. These utilities represent about five percent of the population of coastal communities and about 40 percent of the population of western Oregon.

System / Community	Sector
City of Portland	Water & Wastewater
Tualatin Valley Water District	Water
City of Bend	Water
City of Gresham	Water
City of Pendleton	Water
City of Salem	Water & Wastewater
Clean Water Services	Wastewater
Coos Bay - North Bend Water Board	Water
Eugene Water & Electric Board	Water
Rivergrove Water District	Water

Figure 8.17: Water and Wastewater Systems Participating in the Water and Wastewater Task Group

The Water and Wastewater Task Group also included experts from three universities, consulting engineers who specialize in water and wastewater facilities, and the representatives of a fire and emergency response agency. The task group met monthly from February 2012 through August 2012, building on existing information and on group members’ working knowledge of existing systems to assess the performance of existing systems and estimate the time required to restore water and wastewater service to the populations affected by the scenario earthquake.

RESILIENCE GOALS, OBJECTIVES, AND SCOPE

First, the Water and Wastewater Task Group identified performance goals for the time required to restore water and wastewater service to affected communities. This effort consisted of developing a phased approach to water system upgrades before a Cascadia subduction zone earthquake and recovery after, defining categories or groups of functional characteristics of systems, and identifying resilience goals for each category.

A Phased Approach

Given the size and inherent vulnerability of most water and wastewater systems, it was assumed that costs of seismic mitigation would exceed the resources of most providers’ 50-year capital improvement

programs. Therefore, to provide water to critical areas and establish wastewater service to protect public health and safety as soon as possible following the seismic event, a phased approach to system recovery was developed. The phased approach is built upon having hardened backbone elements of the water and wastewater systems. The backbone system would consist of key supply, treatment, transmission, distribution, and collection elements that, over the 50-year timeframe, have been upgraded, retrofitted, or rebuilt to withstand a Cascadia subduction zone earthquake.

The backbone water system would be capable of supplying key community needs, including fire suppression, health and emergency response, and community drinking water distribution points, while damage to the larger (non-backbone) system is being addressed. The backbone wastewater system would protect the community from health hazards and minimize environmental impacts associated with raw sewage as larger repair and response efforts are underway. Identification of a community's backbone water and wastewater systems would become essential to maximizing the effectiveness of investments in resilience and ultimately to expediting recovery efforts following a Cascadia subduction zone earthquake.

The proposed approach—each community establishes a backbone water system—does not alleviate critical water and wastewater concerns following a Cascadia subduction zone earthquake. Large portions of the water distribution system will remain vulnerable and presumably inoperable. In addition, vulnerabilities of the wastewater collection and treatment system will likely result in raw sewage discharges to receiving waters and public health risks in affected communities.

Functional Categories of Water and Wastewater Systems

Using the professional judgment of group members, the Water and Wastewater Task Group established categories of water and wastewater infrastructure based on functional characteristics of the systems. These categories also reflected the proposed backbone structure to accommodate phased recovery of the systems. The categories of system functions are described below.

Domestic Water Supply

- **Potable water available at supply source (water treatment plants, wells, impoundments).** This category represents the initial point of the finished water supply system. Given the age, geotechnical vulnerability, and complexity of many treatment plants, a phased recovery was assumed and would be dedicated to seismically hardening the treatment processes. Communities with more resilient storage may consider longer recovery timeframes for the supply source, as they could rely on stored water in lieu of producing more treated water.
- **Main transmission facilities, pipes, pump stations, and reservoirs operational.** This category refers to the backbone system discussed above. The intent is to be able to convey water from resilient storage and treatment plants to key distribution points as soon as possible following the event. Manual operation of valves—to isolate the backbone system from damaged areas of the system and minimize water loss—accounts for some of the delay in implementation.

- **Water supply to critical facilities available.** This category assumes critical facilities will be nearly fully operational due to on-site water storage or the capacity of the local supply. Critical facilities, such as hospitals and first-aid facilities, command and control centers, and industries essential to recovery and restoration efforts, should be identified for individual communities.
- **Water for fire suppression at key supply points.** Thorough planning efforts, involving fire officials and emergency responders, should identify key supply points for reliable access to water for fire suppression. These areas should be included in the backbone system.
- **Water for fire suppression at fire hydrants.** Water will be available at fire hydrants when leaks and breaks in the distribution system have been repaired. Communities in heavily damaged areas will likely not be able to rely on fire hydrants until the majority of the distribution system is operational. Until that benchmark can be reached, communities would have to rely on the key fire-suppression supply points and fire-suppression strategies described above.
- **Water available at community distribution centers/points.** As in the case of fire hydrants, the distribution of water to individual homes and neighborhoods may not be possible given damage to the distribution system. If community distribution centers/points are provided at strategic locations along the hardened backbone, people can have access to potable water soon after the event. Such issues as the logistics of staffing and setting up a distribution center and of identifying containers were also considered during the development of the target recovery timeframes for this category.
- **Distribution system operational.** In order to provide water throughout the community (including fire hydrants), the distribution system would need to be operational. Through vulnerability assessment, material stockpiles, supply identification, and workforce planning, communities would be able to target anticipated repairs as part of their comprehensive response and recovery efforts.

Wastewater Systems

- **Threats to public health and safety controlled.** Minimizing the threat to public health and safety must be a top priority. Through vulnerability assessment and system planning, communities can identify key lift stations, river crossings, and components that could pose serious threats to public health and safety and can plan response efforts accordingly.
- **Raw sewage contained and routed away from population.** Closely tied to threats to public health and safety, the intent of this category is to make sure raw sewage can be routed away from the population. A key factor in establishing the target timeframes for this category is the anticipated availability of the workforce, equipment, and back-up power.
- **Treatment plants operational to meet regulatory requirements.** When establishing the target timeframes for these components, the task group considered the typical proximity of wastewater treatment plants to rivers and liquefiable soils. Based on historical events, it was

assumed that treatment plants would at first be operating at lower regulatory requirements given the emergency situation. As repairs are made, the treatment plants would resume meeting applicable discharge requirements.

- **Major trunk lines and pump stations operational.** Through assessment of vulnerability and back-up power capability, communities can identify the key pump stations that will be needed to maintain the functionality of the major trunk lines. As treatment plants return to normal operation, the available storage in the trunk lines can be utilized to store raw sewage as needed to minimize threats to public health and safety and route raw sewage away from the population.
- **Collection system operational.** As repairs to key pump stations, trunk lines, and treatment plants are completed, the available work force, equipment, and resources can be focused on repairing the collection systems that serve individual neighborhoods. Damage to and limited functionality of collection systems should be addressed as part of the comprehensive response and recovery efforts. Community sanitary collection centers and community education efforts should be considered.

WATER AND WASTEWATER RECOVERY GOALS

Recovery goals were established for each functional category for water and wastewater systems. Due to the unique characteristics of various regions of the state, recovery goals were developed for each of three geographic regions: the Oregon coast, the Willamette Valley, and eastern Oregon.

The proposed target recovery times were developed based on the considerations described above, using input from a range of water and wastewater professionals participating in the Oregon Resilience Plan effort, and based on input from the Business Task Group. In general, the recovery goals established by the professionals who participated in the Water and Wastewater Task Group were longer than the two-week goal identified by the Business Task Group. These longer goals were based on the professional judgment of the Water and Wastewater Task Group and took into account the consideration that a goal of two weeks would require replacement of essentially all existing water and wastewater system infrastructure. Finally, the intended objectives of the Business Task Group's goal for a two-week recovery were generally met by the proposed phased approach of a seismically hardened backbone for water and wastewater systems.

The proposed target recovery times are based on typical water and wastewater systems in the specified geographic zone. Estimates of recovery times assume the typical system has implemented comprehensive resilience improvements, including upgrades to its backbone system, over the 50-year planning horizon. It is further assumed that the resilient backbone is capable of withstanding the anticipated impact of a Cascadia subduction zone earthquake with minimal damage. It is recommended that those responsible for individual systems establish their own target recovery goals as part of a system-specific assessment to reflect the particular configuration of the individual system and the needs of the community it serves.

Recovery tables were developed for each of three geographic zones of the state, with performance goals established for each functional category within each zone. These tables include the following:

- Table in Figure 8.18: *Coastal*. This includes the parts of the Coast that are not in tsunami inundation zones and extends as far as the Coast Range.
- Table in Figure 8.19: *Valley*. This includes the Willamette Valley and the western-flank of the Cascades, including major population centers in the state.
- Table in Figure 8.20: *Eastern*. This includes all areas east of the summit of the Cascades.

As shown in the tables, the performance goals for recovery times vary widely within the state. In particular, the target recovery times for the Coastal zone are significantly longer than those of the Valley and Eastern zones. This difference is due in part to the following considerations:

- Coastal communities are physically closer to the fault than the communities in the Valley and Eastern zones and will therefore experience greater physical damage, more disruption, and longer recovery times. Achieving target recovery times similar to those of the other zones will require greater effort and expenditure by coastal communities.
- The population density of the Coastal zone is far lower than that of the Valley zone; therefore, the per capita cost of repairs will likely be far higher for coastal communities. Similarly, the per capita cost for the Eastern zone is expected to be lower given the lower anticipated damage for that zone.
- Coastal communities have fewer resources (in terms of number of residents, available equipment, consultants, and contractors) to aid with the recovery process and help restore systems. The competing priorities of the population and economic centers of the state will also affect the speed at which coastal communities are able to recover. Mobilization of assistance from other jurisdictions will take additional time and be affected by interdependencies with other essential services, including transportation, energy, and communications.

KEY TO THE TABLE

TARGET TIMEFRAME FOR RECOVERY:

Desired time to restore component to 80–90% operational

Desired time to restore component to 50–60% operational

Desired time to restore component to 20–30% operational

Current State (90% operational)

G
Y
R
X

TARGET STATES OF RECOVERY: WATER & WASTEWATER SECTOR (COAST)											
	Event occur s	0–24 hours	1–3 days	3–7 days	1–2 weeks	2 weeks – 1 month	1–3 month s	3–6 month s	6 month s–1 year	1–3 years	3 + years
Domestic Water Supply											
<i>Potable water available at supply source (WTP, wells, impoundment)</i>				R		Y		G		X	
<i>Main transmission facilities, pipes, pump stations, and reservoirs (backbone) operational</i>			R	Y	G					X	
<i>Water supply to critical facilities available</i>				R		Y		G		X	
<i>Water for fire suppression—at key supply points</i>			R		Y			G		X	
<i>Water for fire suppression—at fire hydrants</i>						R	Y	G		X	
<i>Water available at community distribution centers/points</i>				R	Y	G	X				
<i>Distribution system operational</i>					R		Y	G			X

(To be continued on next page)

KEY TO THE TABLE

TARGET TIMEFRAME FOR RECOVERY:

Desired time to restore component to 80–90% operational

Desired time to restore component to 50–60% operational

Desired time to restore component to 20–30% operational

Current State (90% operational)

G
Y
R
X

	Event occurs	0–24 hours	1–3 days	3–7 days	1–2 weeks	2 weeks – 1 month	1–3 months	3–6 months	6 months–1 year	1–3 years	3+ years
Wastewater Systems											
<i>Threats to public health & safety controlled</i>				R	Y		G			X	
<i>Raw sewage contained & routed away from population</i>				R	Y			G		X	
<i>Treatment plants operational to meet regulatory requirements</i>							R		Y	G	X
<i>Major trunk lines and pump stations operational</i>						R		Y	G		X
<i>Collection system operational</i>								R	Y	G	X
	Event occurs	0–24 hours	1–3 days	3–7 days	1–2 weeks	2 weeks – 1 month	1–3 months	3–6 months	6 months–1 year	1–3 years	3+ years

Figure 8.18: Water & Wastewater Sector: Coastal (Non-Tsunami) Zone

KEY TO THE TABLE

TARGET TIMEFRAME FOR RECOVERY:

Desired time to restore component to 80–90% operational

Desired time to restore component to 50–60% operational

Desired time to restore component to 20–30% operational

Current state (90% operational)

G
Y
R
X

TARGET STATES OF RECOVERY: WATER & WASTEWATER SECTOR (VALLEY)											
	Event occurs	0–24 hours	1–3 days	3–7 days	1–2 weeks	2 weeks–1 month	1–3 months	3–6 months	6 months–1 year	1–3 years	3+ years
Domestic Water Supply											
<i>Potable water available at supply source (WTP, wells, impoundment)</i>		R	Y		G			X			
<i>Main transmission facilities, pipes, pump stations, and reservoirs (backbone) operational</i>		G					X				
<i>Water supply to critical facilities available</i>		Y	G				X				
<i>Water for fire suppression—at key supply points</i>		G		X							
<i>Water for fire suppression—at fire hydrants</i>				R	Y	G			X		
<i>Water available at community distribution centers/points</i>			Y	G	X						
<i>Distribution system operational</i>			R	Y	G				X		

(To be continued on next page)

KEY TO THE TABLE

TARGET TIMEFRAME FOR RECOVERY:

Desired time to restore component to 80–90% operational

Desired time to restore component to 50–60% operational

Desired time to restore component to 20–30% operational

Current state (90% operational)

G
Y
R
X

	Event occurs	0–24 hours	1–3 days	3–7 days	1–2 weeks	2 weeks–1 month	1–3 months	3–6 months	6 months–1 year	1–3 years	3+ years
Wastewater Systems											
<i>Threats to public health & safety controlled</i>			R	Y		G			X		
<i>Raw sewage contained & routed away from population</i>		R		Y			G		X		
<i>Treatment plants operational to meet regulatory requirements</i>					R			Y	G		X
<i>Major trunk lines and pump stations operational</i>					R		Y	G			X
<i>Collection system operational</i>							R	Y	G	X	
	Event occurs	0–24 hours	1–3 days	3–7 days	1–2 weeks	2 weeks–1 month	1–3 months	3–6 months	6 months–1 year	1–3 years	3+ years

Figure 8.19: Water & Wastewater Sector: Valley Zone

KEY TO THE TABLE

TARGET TIMEFRAME FOR RECOVERY:

Desired time to restore component to 80–90% operational

Desired time to restore component to 50–60% operational

Desired time to restore component to 20–30% operational

Current state (90% operational)

G
Y
R
X

TARGET STATES OF RECOVERY: WATER & WASTEWATER SECTOR (CENTRAL/EASTERN OREGON)											
	Event occurs	0–24 hours	1–3 days	3–7 days	1–2 weeks	2 weeks–1 month	1–3 month	3–6 months	6 months–1 year	1–3 years	3+ years
Domestic Water Supply											
<i>Potable water available at supply source (WTP, wells, impoundment)</i>		X									
<i>Main transmission facilities, pipes, pump stations, and reservoirs (backbone) operational</i>		X									
<i>Water supply to critical facilities available</i>		X									
<i>Water for fire suppression—at key supply points</i>		X									
<i>Water for fire suppression—at fire hydrants</i>		X									
<i>Water available at community distribution centers/points</i>		X									
<i>Distribution system operational</i>		X									

(To be continued on next page)

KEY TO THE TABLE

TARGET TIMEFRAME FOR RECOVERY:

Desired time to restore component to 80–90% operational

Desired time to restore component to 50–60% operational

Desired time to restore component to 20–30% operational

Current state (90% operational)

G
Y
R
X



		0–24 hours	1–3 days	3–7 days	1–2 weeks	2 weeks–1 month	1–3 months	3–6 months	6 months–1 year	1–3 years	3+ years
Wastewater Systems											
<i>Threats to public health & safety controlled</i>		X									
<i>Raw sewage contained & routed away from population</i>		X									
<i>Treatment plants operational to meet regulatory requirements</i>		X									
<i>Major trunk lines and pump stations operational</i>		X									
<i>Collection system operational</i>		X									
		0–24 hours	1–3 days	3–7 days	1–2 weeks	2 weeks–1 month	1–3 months	3–6 months	6 months–1 year	1–3 years	3+ years

Figure 8.20: Water & Wastewater Sector: Central / Eastern Zone

Assessment of System Performance

The Water and Wastewater Task Group used available data, experience from other similar events, and professional judgment to estimate the performance of existing water and wastewater systems in response to a Cascadia subduction zone earthquake. The task group developed estimates of pipeline failure rates and facility failures and identified other likely failure mechanisms. From these assessments, the task group estimated the recovery times for the existing systems of the water and wastewater

facilities in the coastal and valley zones. This approach and resulting recovery times for existing systems are presented below.

ESTIMATES OF PIPELINE FAILURES

Water Distribution Systems

The process used to predict the performance of water distribution systems included a preliminary inventory of types of pipeline material for six water systems (Portland Water Bureau, Eugene Water and Electric Board, City of Gresham, Tualatin Valley Water District, Coos Bay - North Bend, and Salem). After assembling the available information on pipe lengths and materials, the task group superimposed these distribution systems onto maps of the scenario magnitude 9.0 Cascadia subduction zone earthquake showing peak ground acceleration, liquefaction potential (displacement), and landslide potential. The task group then used empirical data from the American Lifeline Alliance to predict the number of breaks and leaks for typical distribution systems. Figure 8.21 provides a summary of results for the participating utilities. The damage to those systems was assumed generally to represent the degree of damage to all the systems on the coast and in the Willamette Valley.

Characteristic	Estimate
Total Length of Pipe (miles)	4,592
Total Number of Breaks (number)	2,656
Total Number of Leaks (number)	941
Total Number of Services (number)	385,600
Service Line Breaks—Utility Side (2%)	7,712
Service Line Breaks—Customer Side (5%)	19,280

Figure 8.21: Estimate of Water Pipeline Breaks & Leaks for Participating Utilities

Wastewater Collection Systems

There is no comprehensive guideline for wastewater collection system collapses in response to a seismic event. Experience indicates the following general relationships:

- The ratio for sewer pipe collapses to water pipeline breaks and leaks is about 1:10 (in other words, one sewer pipe collapse for every 10 water pipeline breaks and leaks).
- Each collapse requires replacement of about 100 feet of pipe, and one manhole is required for every 400 feet of collapsed pipe (in other words, one manhole replacement is needed for every four sewer collapses).

Based on these assumptions, it was projected that the participating utilities would experience a total of about 360 sewer collapses and about 90 manholes replacements as a result of a Cascadia subduction zone earthquake.

Assessment of Water and Wastewater Structures

Participating utilities also compiled available data on the construction and age of critical water and wastewater facilities, such as treatment plants, pump stations, and reservoirs. To identify the degree and severity of likely failures of existing facilities, the task group compared the age distribution of existing facilities to the building code seismic requirements that were in effect at the time the facilities were constructed. Figure 8.22 is an example of the typical output that the task group used to estimate (for each utility) the damage that facilities may experience.

Based on this preliminary assessment, the following general observations were made regarding existing key structures:

- Reservoirs and Tanks
 - Nearly all reservoirs and tanks are likely to experience some damage at the connection between the buried pipe system and the reservoir structure.
 - 33 percent of total tankage was built before 1960 and had no lateral force requirements—these tanks will most likely fail and release contents.
 - 30 percent of total tankage was built between 1960 and 1970 and had only a .06 gravity lateral force requirement—tanks that are near the epicenter will most likely fail and release contents.
 - 12 percent of total tankage was built between 1970 and 1990 and had only a .12 gravity lateral force requirement—tanks that are close to the epicenter will most likely fail and release contents.
 - 12 percent of total tankage was built between 1990 and 2000 and had somewhat more stringent lateral force requirement—these tanks will most likely suffer some damage, but may not release contents.
 - 13 percent of total tankage was built after 2000 and had stringent lateral force requirements—these tanks will most likely remain intact.
- Pump Stations
 - Nearly all pump stations are likely to experience some damage at the connection between the buried pipe system and pump station structure.
 - 13 percent of pump stations were built before 1960 and had no lateral force requirements—these stations will likely fail structurally and mechanically.

- 22 percent of pump stations were built between 1960 and 1970 and had only a .06 gravity lateral force requirement—these stations will likely fail structurally and mechanically if located near the epicenter.
 - 12 percent of pump stations were built between 1970 and 1990 and had only a .12 gravity lateral force requirement—these stations will likely fail structurally and mechanically if located close to the epicenter.
 - 31 percent of pump stations were built between 1990 and 2000 and had somewhat more stringent lateral force requirement—these stations will most likely suffer some damage, but may be usable after repairs.
 - 19 percent of pump stations were built between 2000 and 2009 and incorporated stringent lateral force requirements—these stations are likely to remain intact and functional.
 - 3 percent of pump stations were built after 2009. They meet current code and are most likely to remain intact and be functional.
- Treatment Plants
 - Water and wastewater treatments will generally respond in similar ways.
 - Treatment plants built on liquefiable soils without special design for liquefiable soils are likely to suffer catastrophic damage due to foundation failures.
 - The identification of and mitigation for liquefaction generally did not become standard practice until the late 1990's.

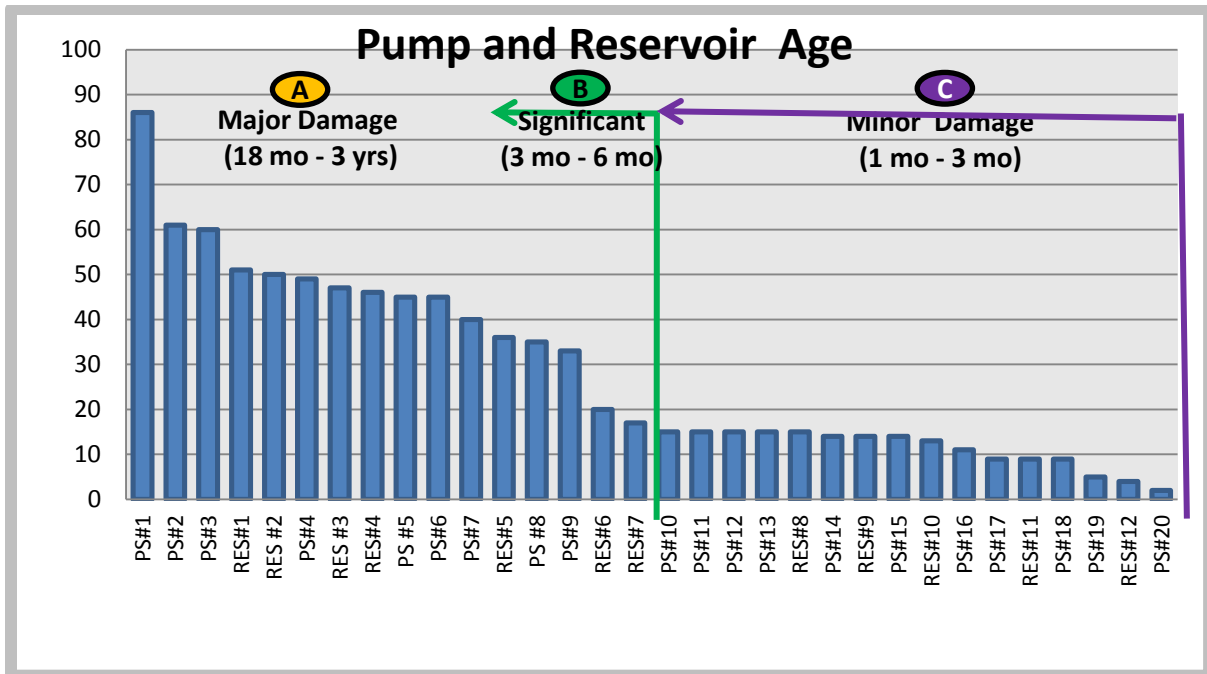

Performance Group	Seismic Retrofit Date	Expected Performance Level	Description of Expected Performance	Approximate Restoration Time
	Pre-1975	Collapse Prevention	*Major Structural Damage *Structure on verge of collapse *Replacement necessary	18 months to 3 years
	1975–1993	Life Safety	*Significant structural and nonstructural damage *Repair possible but replacement may be more economical	3 to 6 months
	1994–Present	Immediate Occupancy, Life Safety	*Minor to moderate structural and nonstructural damage *Repairs needed	1 to 3 months

Figure 8.22: Example of Facility Age Distribution and Building Code Requirements

ADDITIONAL FACTORS

In addition to pipeline failures and the age of facilities, the task group considered other factors when preparing estimates of damage and resulting times to restore water and wastewater services; these factors included seismic hazards, interdependencies, and historical performance.

Anticipated Seismic Hazards

A number of seismic hazards other than shaking and ground motion are associated with a Cascadia subduction zone earthquake.

- *Liquefaction*: Liquefaction occurs when shaking during the seismic event causes a temporary increase in ground water pressure—the result is a loss of soil bearing capacity. Liquefaction can cause structures to settle and pipe connections to shear. The probability of liquefaction occurring is medium to high in the Valley as well as in portions of the Coast. In the Valley, areas such as those near Forest Grove, McMinnville, Albany, Woodburn, and along the Columbia River, have the highest risk of liquefaction. Along the coast, areas such as Astoria, Tillamook, Waldport, Florence, and Coos Bay have the highest risk of liquefaction.
- *Landslides*: The likelihood of permanent ground deformation due to landslides is high to very high for the Coastal and generally low for the Valley and Eastern zones.
- *Lateral spreading*: Displacement of soil structure can cause shearing of pipes and settlement of structures.
- *Shaking*: Sudden ground motion can cause liquids in a tank or reservoir to slosh and impose forces on a tank wall beyond its design capacity. An unanchored tank may rock, breaking connecting piping. As sloshing continues, rocking may cause the tank to buckle or burst. (Barnett, E.A., Weaver, C.S., et al. 2005)
- *Tsunami inundation*: Target recovery times and current recovery times were not established for those portions of the coastal zone that are in the inundation zone.

Interdependencies

A utility provider's ability to respond after the earthquake and restore water and wastewater service to the community will be impacted by the anticipated performance of other areas of the community.

- *Transportation Corridors*. The availability of transportation corridors, including bridges, highways, and rail lines, will impact the ability of repair and response crews to access damaged portions of the system and transport the materials they need to make repairs.
- *Energy and Fuels*. The region is expected to experience widespread electrical power outages and shortages of fuels as a result of a Cascadia subduction zone earthquake. This lack of critical resources will severely limit operation of pump systems and back-up generators; it will also limit the ability of utility providers to transport goods and employees.
- *Supply Chain*. Linked closely with transportation corridors, the ability to locate, purchase, and transport repair materials will impact recovery timeframes.
- *Work Force Availability*. Anticipated damage to community infrastructure, including homes and neighborhoods, will impact the ability of repair and response crews to mobilize. Personal injury and care of family members and dependents will be a high priority for many.

Historical Performance

When estimating recovery times, the task group considered the impacts of recent seismic events in other locations as well as the recovery efforts that followed.

- *Christchurch, New Zealand* (The Stronger Christchurch Infrastructure Rebuild Team, 2012). Water supply was re-established to 70 percent of households within one week. The wastewater treatment plant was badly damaged, although it continued to operate at reduced capacity. As a temporary measure, the effluent pumped into the ocean was not treated to the usual level.
- *Tohoku, Japan* (Floyd, 2012). In the 2011 Tohoku earthquake, 90 percent of people evacuated effectively; although around 20,000 people died or are missing. 200,000 people were in the inundation zone at the time of the earthquake.
- *Haiti*. (Ballantyne, 2012). Before the earthquake, over 50 percent of Port-au-Prince residents had no water service and only 10–12 percent had piped connections with intermittent service. After the earthquake, distribution networks were non-functional for most of the city. The primary water issue is distribution. Sewage collection networks were non-existent in the city before the earthquake and became a major problem in the contamination of fresh water and resulting disease outbreaks.

Estimated Recovery Timeframes for Existing Systems

Estimates of recovery times were developed for each of the three geographic zones of the state, with performance estimates made for each functional category within each zone. The resulting estimates of recovery times for existing systems, without resilience upgrades, are summarized in Figures 8.18, 8.19 and 8.20.

RESILIENCE GAP ANALYSIS SUMMARY

As indicated in Figures 8.18 and 8.19, existing water and wastewater systems are generally not able to meet the target recovery goals. This section presents notable gaps between performance goals and estimated recovery times for existing systems and summarizes typical seismic improvements needed to achieve the performance goals. Due to the distance between the epicenter of the earthquake and the facilities, damage within the Eastern zone (Figure 8.20) was not considered of sufficient consequence to warrant further analysis at this time.

PERFORMANCE GAPS

The water and wastewater sector tables for the Coastal and Valley zones (Figures 8.18 and 8.19) reveal significant gaps between the desired performance goals and anticipated performance of existing facilities. In general, performance of water systems in the Valley will be gauged based on availability of water at critical facilities (such as hospitals), which will establish the degree of mitigation necessary. In the Coastal zone, the need for fire flows at key supply points tends to establish the critical degree of

mitigation necessary. For both Coastal and Valley wastewater systems, the need to contain raw sewage overflows and control threats to public health tends to establish the degree of mitigation necessary.

It is important to recognize that the identified gaps reflect anticipated goals and performance for a typical system. In fact, each community or system must conduct its own seismic assessment of the existing facilities, determine what expectations the governing board and the community have for post-earthquake performance of the system, and develop a plan to achieve those expectations.

General observations regarding performance gaps and potential mitigation strategies that may be required to bridge these gaps are summarized below. Assumptions behind these observations are summarized in Figure 8.23.

In reviewing the proposed mitigation scenarios, seismically induced liquefaction stands out as a common vulnerability of critical facilities, because nearly all water and wastewater treatment plants are built near rivers. These facilities were built at times when seismically induced liquefaction was not well understood. Mitigation of seismically induced liquefaction at many of these plants may not be possible in a practical sense, because it would require reconstruction of existing foundations of large treatment structures while the existing facilities remain in operation. Effective mitigation of this critical and widespread vulnerability may require rebuilding these plants on more stable soils.

Water Systems

Notable performance gaps include:

- Water supply at critical facilities (90 percent level) will require one to three years on the Coast and one to three months in the Valley.
- Water supply for fire suppression at key supply points (90 percent level) will require one to three years on the Coast and three to seven days in the Valley.

For typical systems, potential improvements needed to achieve performance goals in the Coastal zone include:

- Hardening transmission facilities (river crossings, bridges, landslide areas, etc.) where possible.
- Replacing existing transmission facilities where hardening is impractical or impossible.
- Installing additional line valves to isolate damaged sections.
- Stockpiling critical replacement parts.
- Hardening valve and other control facilities.
- Providing for vacuum relief valves where needed to prevent pipeline collapse.
- Installing earthquake shutoff valves at appropriate locations.

- Replacing vulnerable pump stations built before 1970; hardening (as needed) pump stations that were built after 1970 so that they meet current standards.
- Replacing flow control equipment when it reaches the end of its current economic life.
- Rebuilding and redesigning transitions between soft piping, such as mains and hard piping at tanks and pump stations.
- Replacing 20 to 30 percent of the transmission systems using more earthquake resistant design standards and more earthquake resistant materials.
- Replacing 20 to 30 percent of the distribution systems using more earthquake resistant design standards and more earthquake resistant materials.
- Replacing tankage built before 1960 with earthquake resistant designs.
- Hardening tankage built after 1960 so that it meets current codes.
- Incorporating seismic resilience objectives into future capital improvement projects.

For typical systems, potential improvements needed to achieve performance goals in the Valley zone include (dates provide only general guidance):

- Hardening existing transmission facilities (river crossings, bridges, liquefaction, landslide areas, etc.) where possible.
- Replacing existing vulnerable transmission facilities where hardening is impractical or impossible.
- Installing additional line valves to isolate damaged sections.
- Stockpiling critical replacement pieces.
- Hardening valve and other control facilities.
- Providing for vacuum relief valves where needed to prevent pipeline collapse.
- Installing earthquake shutoff valves at appropriate locations, such as selected storage facilities and areas of the distribution system that are highly vulnerable.
- Replacing pump stations built before 1970; hardening pump stations built after 1970 so that they meet current standards.
- Replacing flow control equipment when it reaches the end of its current economic life.
- Rebuilding and redesigning transitions between soft piping, such as mains and hard piping at tanks and pump stations.
- Replacing 80 to 90 percent of the transmission facilities using more earthquake resistant materials.

- Replacing 20 to 30 percent of the distribution systems using more earthquake resistant design standards and more earthquake resistant materials.
- Replacing tankage built before 1960 with tankage of earthquake resistant design.
- Hardening tankage built after 1960 so that it meets current code.
- Incorporating seismic resilience objectives into future capital improvement projects.

Wastewater Systems

Notable performance gaps include the following:

- Threats to public health and safety are expected to exist for one to three years on the Coast and six months to a year in the Valley.
- Less than 90 percent of the raw sewage is expected to be contained or routed away from the population centers for one to three years on the Coast and for six months to a year in the Valley.

Research is required to develop sewer designs that will be resistant to permanent ground deformation resulting from a Cascadia subduction zone earthquake.

For typical systems, potential improvements needed to achieve performance goals in the Coastal zone include:

- In liquefiable soils, replacing 50 to 60 percent of the collection system with more earthquake resistant materials.
- In liquefiable soils, replacing 50 to 60 percent of the trunk lines with more earthquake resistant materials.
- Relocating or seismically upgrading wastewater treatment plants built before 2000 and all treatment plants built in areas subject to liquefaction.
- Rebuilding or seismically hardening pump stations built before 2000.
- Providing for emergency power and emergency treatment chemicals.
- Incorporating seismic resilience objectives into future capital improvement projects.

For typical systems, potential improvements needed to achieve performance goals in the Valley zone include:

- In liquefiable soils, replacing 50 to 60 percent of the collection system with more earthquake resistant materials.
- In liquefiable soils, replacing 80 to 90 percent of the trunk lines with more earthquake resistant materials.

- Relocating or seismically upgrading wastewater treatment plants built before 2000 and all treatment plants built in areas subject to liquefaction.
- Upgrading or seismically hardening pump stations built before 2000.
- Providing for emergency power and emergency treatment chemicals.
- Incorporating seismic resilience objectives into future capital improvement projects.

Number	Assumption
1	Recovery tables for the Coast and Valley represent an accurate assessment of what the impact of a magnitude 9.0 Cascadia earthquake on the resource would be should the earthquake occur now; sector tables also represents a consensus regarding the timeframes desired to make Oregon more resilient in 2063 should the same scenario occur then.
2	In the absence of other vulnerability studies, analysis of the facilities of Eugene Water & Electric Board (EWEB) is indicative of performance of similar facilities in the Willamette Valley.
3	Segregation of Coastal, Valley and Eastern responses is appropriate for this level of discussion.
4	Availability of other components of the infrastructure, such as electric power and chemicals, will not be a factor in achieving the desired 2063 restoration timeframes. That is, the water and wastewater industry needs to plan to be resilient without other infrastructure, such as power, telecommunications, and banking. Another assumption is there will be limited availability of construction materials, contractors, chemical deliveries, financial resources, and so forth.
5	Time-block brackets in the columns on the two tables represent the timeframe for the desired availability. Infrastructure will be available sometime in the time block, but this will most likely be toward the end of the bracketed time rather than beginning. For example, the first column is labeled 0–24 hours. It is unlikely that resources will be available one minute or one hour or even 12 hours after the primary shaking stops; it is more likely that resources will be available near the end of the first 24 hours after the event. The expectation of timeframes needs to be clearly communicated to emergency services, hospitals, and other first responders.
6	In many instances, the three time targets (20–30%, 50–60%, and 80–90% operational) make little difference in the development of resilience scenarios; many of the facilities likely to be damaged cannot be repaired in the time difference given between blocks, because there will not be enough skilled human resources in the region to repair mains or fix treatment plants.
7	Mitigation of external vulnerabilities, such as liquefaction, landslides, and fires at buildings on adjacent properties, is a part of the gap analysis.
8	The gap will be closed (more or less) using the economic resources linearly (1/50 per year), with the most effective mitigation—focused on the system’s backbone—taking place first.
9	The information presented in this report outlines the additional resources needed and not the replacement of infrastructure that would naturally take place as infrastructure wears out or exceeds its practical or economic life.
10	With the exception of the pipes, the damage estimates, recovery timeframes, and required expenses are the same for both wastewater treatment systems and water systems; for example, if it takes a month to fix a water pump station, it will take a month to fix a similarly damaged wastewater lift station.
11	Discharge of raw sewage is permissible during the initial period of a declared emergency, but compliance with most applicable discharge regulations will be required after the emergency period ends.
12	80 percent availability means that 80 percent of a given system will be available, not that 80 percent of the system capacity will be available.
13	The members of the task group expect that the material in this report will be communicated with stakeholders, such as elected officials and the public at large. It is hoped that agreement can be reached concerning stakeholders’ expectations and the resources needed to fulfill those expectations. Negotiation to balance expectations and resources must take place.

Figure 8.23: Assumptions Related to Performance Gaps and Proposed Seismic Mitigation Improvements



Recommendations

► **Begin aggressive public information efforts to re-set public expectations for a realistic response time. Local governments should consider using local and state planning processes and tools to integrate seismic resilience into their community development and hazard preparation policies.**

- The old guideline of having a 72-hour emergency survival kit falls far short of the anticipated needs given the extensive impacts of a Cascadia subduction zone earthquake. Even if basic supplies could be readily and broadly dispersed, it would likely take more than three days to achieve that dispersal, and emergency supplies would still fall short of what many people need to avoid deteriorating health (for example, medications, medical equipment, and ongoing healthcare support). There is clear value in members of the public having robust emergency supplies. In many areas, subsistence levels of food and water may be available within a week, but the public should be advised that response will take much more than 72 hours, and recovery times will likely be measured in months. This is especially important in coastal communities where response times could be measured in weeks, and recovery times could be measured in years.
- The majority of jurisdictions in Oregon maintain local hazard mitigation plans, which can incorporate hazard identification, vulnerability and risk assessments, and mitigation strategies of public facilities and services. *Oregon's Statewide Planning Goals and Guidelines*, especially Goal 7 (Areas Subject to Natural Hazards) and Goal 11 (Public Facilities and Services), provides an opportunity through the Comprehensive Plan process to address the vulnerabilities of water and wastewater systems and devise policies and implementing measures to reduce risk.

► **Public agencies should be advised that the Oregon Water/Wastewater Agency Response Network (ORWARN) is a vital resource and membership is recommended.**

ORWARN consists of member utilities and cities that provide mutual-aid response following an emergency. It is recommended that all water and wastewater service providers in the state join. This applies to agencies from both sides of the Cascades, because agencies from eastern Oregon will potentially become vital service providers to their counterparts on the coast and in the valley.

► **Service providers from all sectors should be required to have a seismic response plan that includes resources normally provided by a functioning infrastructure.**

Communities are highly dependent on multiple service providers. These providers need comprehensive emergency response and recovery plans in order for their staff and related resources (contractors, consultants) to address seismic events. Non-infrastructure resources, such as emergency supplies of food and water, communications (including satellite phones), and sister-agency relationships, are vital resources for meeting emergency response and recovery

requirements. Event planning and training at the community level are important tools for building these response networks.

► **Service providers from all sectors are advised to plan for and support employee preparedness.**

Previous events have demonstrated that the availability of employees can become a limiting factor in timely response and recovery of vital services following an event. To minimize delays in response and recovery, critical service agencies should provide their employees with the information and training they require to ensure that their families are safe and cared for. Employees have primary responsibility for their own and their families' preparedness; employers should clearly communicate preparedness expectations, but should also provide as much support as practical.

► **Water-related industry associations and manufacturers should be strongly encouraged to evaluate the need for seismic design standards for pipelines.**

Industry associations, such as the American Water Works Association and the Water Environment Federation, currently do not have seismic standards for the design of pipelines. These associations should be encouraged to develop such standards and to educate their members on the availability and application of the standards.

► **Service providers for all essential sectors should be encouraged to develop business continuity plans.**

In light of the highly interdependent nature of essential service sectors, all essential service providers should be encouraged to coordinate with other service providers to assure availability of essential services following an event. For example, water providers will need access to mapping of other buried utilities to complete repairs of water pipelines. Each essential service provider also needs to be prepared to sustain and maintain its workforce to avoid creating impediments to other service providers. This may include resources such as on-call contracts/agreements with contractors, consultants, and suppliers of other essential resources (for example, fuel suppliers, material suppliers, and equipment suppliers) to establish priorities and commitments following events.

► **Seismic vulnerability criteria should be incorporated into overall capital improvement project planning and asset management priorities.**

Investing in infrastructure solely for improved seismic resilience may be too costly in many cases; however, a phased implementation of improvements can provide multiple benefits (improved capacity, better reliability, and reduced operation and maintenance costs). Service providers are encouraged to take advantage of planned renewal and replacement projects as opportunities to improve seismic resilience at relatively limited incremental cost.

Water-Specific Recommendations

- ▶ **Require water systems to complete a seismic risk assessment and mitigation plan as part of the existing requirement for five-year updates to water system master plans.**

It is assumed that the Oregon Health Authority (OHA) would add this requirement to existing requirements for water system master plans. The required seismic risk assessment would identify and assess the likelihood and consequences of seismic failures. The resulting seismic assessment and mitigation plan would be subject to review and verification of documentation as part of the routine water system survey performed by OHA. The risk assessment should include a process for establishing target recovery goals for the area served. Seismic criteria may be based on hazard vulnerability analyses, building codes, and the findings of the Oregon Department of Geology and Mineral Industries (DOGAMI), because not all systems in Oregon (for example, those in eastern and central Oregon) may need to plan for a Cascadia subduction zone earthquake.

- ▶ **Encourage firefighting agencies and water providers to establish joint standards for use in planning the firefighting response to a large seismic event.**

Water providers, fire departments, and emergency managers should lead their communities in establishing realistic standards and clear, mutually adopted expectations for water supply and firefighting priorities in the aftermath of a Cascadia subduction zone earthquake. This would result in joint fire and water decisions on strategies such as seismic valves and auxiliary water supply points. Rather than mandating a one-size-fits-all standard, the resulting solutions should be community-specific.

- ▶ **Water providers should be required to identify and coordinate key water supply points as part of periodic updates to water system master plans.**

Water providers, in coordination with emergency response agencies and transportation agencies, should plan for key water supply and distribution points for firefighting as well as supply points for public distribution of emergency supplies. In many cases, minor investments in system infrastructure may be required to maximize the effectiveness, safety, and security of these supply points.

- ▶ **The Oregon Health Authority (OHA) should be encouraged to include a seismic design requirement as part of routine design review of water system improvements.**

OHA currently provides review and approval of proposed designs of water system improvements. OHA review should include verification that seismic considerations have been incorporated into the design of proposed projects. It is not intended that OHA would verify the adequacy of the design; rather, OHA would simply confirm that seismic criteria were incorporated in the design. The goal of this recommendation is to ensure that seismic considerations are incorporated into designs for critical facilities. A review might include checking for items such as flexible connections to tanks, use of restrained joints, and consideration of geologic hazards. This additional verification is especially

important for pipelines, because there are currently no seismic standards for pipeline design (in contrast, the building code establishes seismic design requirements for structures).

- ▶ **Encourage the Oregon Department of Environmental Quality (DEQ) and the Oregon Health Authority (OHA) to establish goals and expectations for post-earthquake regulatory compliance and applicable standards.**

DEQ and OHA should work with utilities to establish acceptable practices and operational standards for use during emergency conditions. For example, will it be acceptable to discharge into waters of the state the chlorinated water from main breaks and main repairs? The agencies should also work together to:

- Identify and address potential analytical laboratory capacity limitations.
- Identify potential regulatory and laboratory strategies.
- Provide training to utilities on resulting recommendations.

Wastewater-Specific Recommendations

- ▶ **Require wastewater agencies to complete a seismic risk assessment and mitigation plan as part of periodic updates to facility plans.**

It is assumed that the Oregon Department of Environmental Quality (DEQ) would add this requirement to existing requirements for facility plans. The required seismic risk assessment would identify and assess the likelihood and consequences of seismic failures. The resulting seismic assessment and mitigation plan would be subject to review and verification of documentation as part of the routine assessments conducted by DEQ. The risk assessment should include a process for establishing target recovery goals for the area served. Seismic criteria may be based on hazard vulnerability analyses, building codes, and the findings of the Oregon Department of Geology and Mineral Industries (DOGAMI), because not all systems in Oregon (for example, eastern and central Oregon) may need to plan for a Cascadia subduction zone.

- ▶ **Wastewater agencies should be encouraged to conduct more complete characterizations of the impacts of estimated recovery times for seismic events.**

In preparing this report, the Water and Wastewater Task Group found that data on the anticipated performance of Oregon's wastewater systems in response to a seismic event is limited. Once additional information becomes available as a result of implementing the preceding recommendation, it is further recommended that this resilience plan be updated accordingly.

- ▶ **Encourage the Oregon Department of Environmental Quality (DEQ) to identify and coordinate with wastewater agencies on expectations for the levels of service, regulatory compliance, and applicable standards to be used following a major seismic event.**

DEQ should work with utilities to establish acceptable practices and operational standards for use during emergency conditions. For example, will it be acceptable to discharge raw sewage to receiving water following a disaster declaration? DEQ should also attempt to:

- Identify and address potential analytical laboratory capacity limitations.
- Identify potential regulatory and laboratory strategies.
- Provide training to utilities on resulting recommendations.

► **Encourage public health and wastewater agencies to coordinate and establish agreements for the use of temporary sanitary services (portable toilets) immediately after a seismic event.**

There are currently no clear lines of authority or defined responsibilities for temporary, emergency sanitation services such as portable toilets. To the extent possible, this should be pre-established by public health and wastewater service providers.

► **Encourage public health, water, and wastewater agencies to plan for significant water quality impacts to the Willamette and Columbia rivers downstream from Portland.**

It is likely that there will be extensive impacts due to potential failure of pipes at river crossings, leaking from fuel storage tanks, and other contamination and untreated discharges. This could result in significant adverse impacts on water supply for downstream communities that draw water from the Columbia River.

References

1. American Lifelines Alliances (2011). *Seismic Fragility Formulations for Water Systems*.
2. Ballantyne, D. (2012). “Water, Wastewater, and Drainage Systems”, *Haiti M_w 7.0 Earthquake of January 12, 21010, Lifeline Performance*, edited by Curtis Edwards. ASCE Technical Council on Lifeline Earthquake Engineering, Monograph No. 35, Washington D.C.
3. Barnett, E. A., Weaver, C.S, et al. (2005). “Lifelines and Earthquake Hazards along the Interstate 5 Urban Corridor: Woodburn, Oregon to Centralia, Washington”. Poster.
4. Benjamin, Y. (2012). “Water, Sanitation, and Hygiene situation in Haiti as of 1/21,” <http://blog.sfgate.com/ybenjamin/2010/01/22/water-sanitation-and-hygiene-wash-situation-in-haiti-as-of-121/>. Retrieved August 30, 2012.
5. Floyd, M. (2012). “Lessons for the Pacific Northwest: Japanese death toll could have been worse”. Oregon State University.
6. Stronger Christchurch Infrastructure Rebuild Team (2012). “Rebuilding the fresh water network,” <http://strongerchristchurch.govt.nz/work/fresh-water/fixing>. Retrieved August 30, 2012.
7. Wang, Yumei. Undated. “Tsunami Vertical Evacuation Refuge Activities in Oregon,” Department of Geology and Mineral Industries.

9. Looking Ahead

This *Oregon Resilience Plan* focuses on Oregon's physical infrastructure, with a special emphasis on business and community continuity following a Cascadia earthquake and tsunami. Because the state's physical infrastructure supplies the foundation for community resilience, we believe that the recommendations proposed here, if implemented over the next 50 years, will enhance our infrastructure, strengthen our communities, and support the growth of the state's economy.

This is a timeframe much longer than typical of government planning efforts, but the *Oregon Resilience Plan* is intended to inform and underpin statewide policies. To affirm Oregon's commitment to sustained action, OSSPAC needs to work with the Joint Ways & Means Committee of Oregon's Legislative Assembly to track and report on progress toward seismic resilience at the beginning of each legislative session, to keep the 50-year goal in view.

Because the level of economic development and the condition of infrastructure varies among Oregon communities, we suggest that local communities use the framework and the gap-analysis methodology presented in this report to conduct more refined assessments of local seismic and tsunami hazards, and develop community-specific recommendations to meet their unique response and recovery needs.

A Cascadia earthquake and tsunami will affect both Oregon and Washington. Both states share common challenges, among them the interstate bridges and the Columbia River navigation channel as well as the regional power grid and liquid fuel supply. In particular, Oregon gets almost one hundred percent of its liquid fuel from suppliers in Washington, delivered via pipeline and river. We believe that it would be beneficial for both states to work together at a regional level to address the common challenge of resilience to a region-wide seismic event. The "Resilient Washington State" initiative, completed this year by the Seismic Safety Committee of Washington State's Emergency Management Division, supplies an opportunity to begin.

The challenges of resilience are not limited to disaster preparedness; they are being recognized in many areas that require foresight and the coordination of public and private sector efforts. We encourage a broader public conversation that will bring other state agencies, businesses, and interest groups to the table for an exploration of resilience with respect to natural hazards, land use, climate change, and other topics characterized by systems interdependencies and long-time horizons. We have much to learn from one another about this new way of thinking.

This planning effort, with its emphasis on seismic resilience, is OSSPAC's first attempt to consider seismic risk from a perspective other than emergency preparedness and response. The report, compiled entirely by volunteers who contributed their skills and expertise, is less comprehensive than we might have wished, due to the limited time and resources available for the task. OSSPAC intends to monitor events around the world, and to update and augment the report as we are able to do so. We already recognize

the need to expand the planning effort in the future to include the following areas: (1) local community planning, (2) human resilience, (3) civic infrastructure, and (4) joint regional planning with Washington State.

The *Oregon Resilience Plan* is fundamentally about people—about preserving our communities and workforce to help businesses bounce back quickly from a natural disaster, so that the energies of commerce can propel recovery. Infrastructure investment will certainly lay a solid foundation to make timely recovery possible. However, human resilience supported by Oregon’s civic infrastructure (community-based, non-governmental, and faith-based organizations) is needed to achieve full community resilience.

From natural disasters around the world, we have learned that civic infrastructure is especially critical during the first weeks after a disaster, before organized government assistance can be delivered. We believe that civic organizations, too, need to conduct seismic vulnerability assessment and to develop mitigation plans to ensure that expected services will be delivered.

On the topic of human resilience, we recognize the paramount importance of public health. We urge a commitment to the education and outreach necessary to keep the state’s population as healthy as possible, so that the citizens themselves are ready physically and mentally to withstand disasters of any form.

Personal preparedness is a cornerstone of human resilience. Private and nonprofit sector leaders including the American Red Cross, drawing on experience with disaster response and recovery in many settings, emphasize a need to design and deliver training that reaches all students and educators in Oregon’s K-12 schools, all local government employees, and all employees and guests of Oregon’s tourism industry. The state, along with business leaders, must do more to support and facilitate these efforts. Everyone will play a role in disaster response and recovery; training must reach beyond those public and private sector employees who have essential response duties.

A resilient physical infrastructure, a healthy population, and a robust government and civic infrastructure to provide services to those in need will equip Oregon to withstand a Cascadia earthquake and tsunami, and to expedite response and recovery efforts. With determination, we can achieve that goal.

Appendix I HR-3 and Supporting Documentation

Enrolled

House Resolution 3

Sponsored by Representative BOONE; Representatives COWAN, KRIEGER, ROBLAN, WITT, Senators COURTNEY, JOHNSON, KRUSE, VERGER, WHITSETT

Whereas Oregon is known to be seismically active, with geological faults creating earthquake hazards in most of the state, including its most highly populated counties; and

Whereas the most serious risks linked to earthquakes in Oregon are associated with the Cascadia fault, recognized as one of the world's most dangerous faults and capable of generating megathrust earthquakes at least 1,000 times more powerful than the magnitude 6.8 Nisqually, Washington, earthquake of February 2001 and producing associated tsunamis capable of affecting extensive areas of the Oregon coast; and

Whereas geological evidence documents about 41 earthquakes of magnitude 8 and larger on sections of the Cascadia fault during the last 10,000 years, yielding an average interval between events of about 240 years; and

Whereas the most recent megathrust earthquake on the Cascadia fault, estimated to be about magnitude 9, occurred on January 26, 1700; and

Whereas many of the earthquakes on the Cascadia fault have been separated by intervals shorter than the time elapsed since the most recent Cascadia earthquake; and

Whereas an earthquake of magnitude 8 or larger and its associated tsunami would have devastating impacts to coastal communities and throughout western Oregon, causing thousands of casualties and premature deaths and inflicting tens of billions of dollars in physical damage that would have crippling impacts on the state's economy; and

Whereas policies now in place are insufficient to protect citizens and businesses in Oregon from the ground shaking and waves associated with a Cascadia megathrust earthquake and to ensure a smooth economic recovery after that event; now, therefore,

Be It Resolved by the House of Representatives of the State of Oregon:

That concern for the protection of life and the resumption of commerce should guide the State of Oregon in the development and implementation of resilience policies that address the risks posed by a Cascadia megathrust earthquake and tsunami; and be it further

Resolved, That Oregon's most forward-thinking policies and programs to advance resilience to earthquakes include the Seismic Rehabilitation Grant Program, fully enacted with general obligation bond funding by the 75th Legislative Assembly in 2009; and be it further

Resolved, That the strengthening of collapse-prone public structures, including, but not limited to, K-12 schools, community colleges and public safety facilities, should be recognized by the Governor and Legislative Assembly as top investment priorities in this state's capital budget; and be it further

Resolved, That seismic improvements to K-12 schools, community colleges and public safety facilities funded by Seismic Rehabilitation Grants should be recognized with placards affixed to the reinforced structures; and be it further

Resolved, That this state's investment in Seismic Rehabilitation Grants and in other programs and resources to accomplish seismic upgrades of public buildings should be expanded to the extent fiscal prudence allows; and be it further

Resolved, That this state should make investments in additional evacuation options for Oregon coastal communities that cannot ensure adequate protection of their residents and visitors from tsunamis because of distance from safe ground; and be it further

Resolved, That this state should make investments necessary to establish a Critical Transportation Infrastructure providing reliable lifelines for emergency response and economic recovery in the aftermath of a Cascadia earthquake and tsunami; and be it further

Resolved, That this state should make investments necessary to establish a Critical Energy Infrastructure comprising transmission networks for electricity, liquid fuels and natural gas hardened to withstand a Cascadia earthquake and tsunami; and be it further

Resolved, That seismic resilience should be viewed as a necessary complement to environmental sustainability and endorsed as a priority by the Governor and the Legislative Assembly; and be it further

Resolved, That the Seismic Safety Policy Advisory Commission should lead and coordinate preparation of an Oregon Resilience Plan that reviews policy options, summarizes relevant reports and studies by state agencies and makes recommendations on policy direction to protect lives and keep commerce flowing during and after a Cascadia earthquake and tsunami; and be it further

Resolved, That the commission should enlist the participation of the Governor's public safety advisor, state agencies, commissions and other advisory bodies, as needed, to assemble an integrated view of current state capabilities and gaps in resilience planning; and be it further

Resolved, That the Oregon Resilience Plan and recommendations should be delivered to the Legislative Assembly no later than February 28, 2013, so that the inevitable natural disaster of a Cascadia megathrust earthquake and tsunami does not cause an unprecedented catastrophe for the State of Oregon.

Adopted by House April 18, 2011

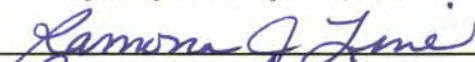

Ramona Kenady Line, Chief Clerk of House

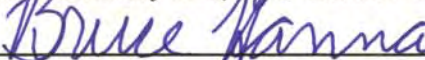

Bruce Hanna, Speaker of House

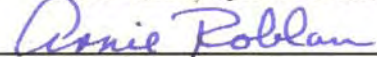

Arnie Roblan, Speaker of House



NATIONAL SECURITY STAFF
WASHINGTON, D.C. 20504

December 7, 2011

Kent Yu, PhD
Chairman, Oregon Seismic Safety Policy Advisory Commission
P.O.Box 14370
Salem, OR
97309 5062

Dr. Yu:

On Tuesday, November 8, 2011 I had the pleasure of spending time with the working session of the National Earthquake Hazard Reduction Program (NHERP) Advisory Committee. There, I was honored to meet Deborah Boone, Oregon State Representative and sponsor of Oregon House Resolution 3, which directs the creation of an Oregon Resilience Plan to prepare for the statewide impacts of a Cascadia earthquake and tsunami. I would like to wholeheartedly applaud Representative Boone, yourself, and the rest of the Oregon Seismic Safety Policy Advisory Commission on this initiative..

President Obama's top priority is the safety and security of the American people. I thank you for your leadership and your ongoing contribution to our Nation's resilience.

Sincerely,



Richard Reed
Special Assistant to the President for
National Security Affairs and
Senior Director for Resilience

**Deborah Boone
State Representative
HD 32**



**900 Court Street NE
Salem, OR 97301
503-986-1432**

October 17, 2011

Richard A. Reed
Senior Director for Resilience Policy
National Security Council
The White House
1600 Pennsylvania Avenue NW
Washington, DC 20500

Dear Mr. Reed,

I am writing in regard to your responsibility for implementation of Presidential Policy Directive 8 on National Preparedness. According to that Directive, *"Each national planning framework shall include guidance to support corresponding planning for State, local, tribal, and territorial governments."*

During the November 2011 meeting of the NEHRP Advisory Committee on Earthquake Hazard Reduction, I have asked Advisory Committee member Yumei Wang to share with you a copy of Oregon House Resolution 3, which I sponsored and my colleagues adopted unanimously in Oregon's House of Representatives on April 18, 2011.

H.R. 3 directs our state Seismic Safety Policy Advisory Commission (OSSPAC), on which I serve, to prepare an Oregon Resilience Plan to make recommendations on policy direction to protect lives and keep commerce flowing during and after the next Cascadia earthquake and tsunami expected to strike our state.

This is the first step Oregon will take to prepare comprehensively for the statewide impacts of a Cascadia earthquake and tsunami, and the only example of state legislation to initiate seismic resilience planning of which I am aware. Our intent is to address, to the extent feasible, the five mission areas identified in PPD-8: prevention, protection, mitigation, response, and recovery.

I would like to request your endorsement in writing of Oregon's resilience planning efforts, as a State initiative consistent with the intent of PPD-8 and worthy of support in its development and implementation by all branches and agencies of Oregon's state government and by appropriate

federal agencies.

Your letter to OSSPAC Chairman Dr. Kent Yu (address below) endorsing Oregon's resilience planning commitment will provide timely encouragement as we begin to engage the state's leadership in preparing the Oregon Resilience Plan during the next several months.

Thank you for your dedication to national preparedness and resilience.

Sincerely,

Rep. Deborah Boone

Cc: Kent Yu, Ph.D
Chairman
Oregon Seismic Safety Policy Advisory Commission (OSSPAC)
Attn: Beverly Hall
Oregon Emergency Management
P.O. Box 14370
Salem, OR 97309-5062

Encl.: H.R. 3 enrolled



JOHN A. KITZHABER, MD
Governor

January 4, 2012

Kent Yu, Ph.D, Chair
Oregon Seismic Safety Policy Advisory Commission
P.O. Box 14370
Salem, OR 97309

Dear Dr. Yu,

The Oregon Seismic Safety Policy Advisory Commission (OSSPAC) has a challenging mission to educate the public about our seismic risks and inform diverse policy decisions. Through OSSPAC's dedicated efforts, though, the State of Oregon and its citizens have become increasingly aware that we live in an earthquake-prone region.

This month will mark the 312th anniversary of the last major earthquake and resulting tsunami from the Cascadia Subduction Zone that sits off Oregon's coast. Throughout this year, OSSPAC will be drafting an Oregon Resilience Plan to help us better prepare for the next major earthquake and tsunami.

A focused resiliency effort can better prepare us for catastrophic disasters as well as help us weather our more common emergencies like storms, floods and fires. OSSPAC has had wide participation from state agencies, local governments, businesses and non-profits and I encourage their continued engagement on this critical effort.

Thank you for all of OSSPAC's efforts to date and for continuing to be a powerful voice for a more prepared and resilient Oregon.

Sincerely,

John A. Kitzhaber, M.D.
Governor

JAK/CS/ap



A RESOLUTION requesting that the Cascadia Region Earthquake Workgroup endorse Oregon State and Oregon Seismic Safety Policy Advisory Council in creating a more resilient state through their resiliency planning efforts in support of 2011 Oregon House Resolution 3 (Oregon Resiliency Planning).

WHEREAS, a Cascadia Subduction Zone generated earthquake and tsunami poses significant risk to life, property, the environment, and the regional economy, and

WHEREAS, the Cascadia Region Earthquake Workgroup, has a vision of a disaster resilient region, and

WHEREAS, the Cascadia Subduction Zone represents a common hazard in the Pacific Northwest and the shared risk that affect the Cascadia Region; and

WHEREAS, the Cascadia Region Earthquake Workgroup supports efforts to reduce vulnerability,

NOW THEREFORE,

BE IT RESOLVED BY THE BOARD OF DIRECTORS THAT:

The Cascadia Region Earthquake Workgroup is supportive of the goals and objectives identified in 2011 Oregon House Resolution #3; and

Resolved, that the Cascadia Region Earthquake Workgroup will provide support similar to that provided to Washington State Seismic Safety Committee's Resilient Washington State Initiative; and

Resolved, that the Cascadia Region Earthquake Workgroup will help promote the findings of resilience planning efforts from the Pacific Northwest to further reduce identified risks and improve seismic resilience.

Adopted by the Cascadia Region Earthquake Workgroup Board of Directors this 25th day of January, 2012, and signed by me in authentication of its adoption this 25th day of January, 2012.

A handwritten signature in black ink, appearing to read "Cal Ah", is written over a horizontal line.

President of the Cascadia Region Earthquake Workgroup

Appendix II January 26, 2012 workshop



Oregon

John A. Kitzhaber, MD, Governor

Seismic Safety Policy Advisory Commission

Oregon Emergency Management

Mailing Address: PO Box 14370

Salem, OR 97309-5062

Phone: (503) 378-2911

Fax: (503) 373-7833

Oregon Resilience Planning Overview

Background

A Cascadia earthquake and tsunami has the potential to cause an unparalleled economic and human catastrophe for the State of Oregon because its impacts are region-wide. Over 40 great earthquakes of magnitude 8 and larger have struck Western Oregon during the last 10,000 years. The current calculation of a 37% conditional probability that a Cascadia earthquake will strike Oregon within the next 50 years means that it is now prudent to understand and take steps to mitigate this risk to our economy and to our businesses, homes, and communities.

In April 2011, the Oregon House of Representatives unanimously passed House Resolution 3 (sponsored by Rep. Deborah Boone, D-Cannon Beach), which directs Oregon Seismic Safety Policy Advisory Commission (OSSPAC) to “lead and coordinate preparation of an Oregon Resilience Plan that . . . makes recommendations on policy direction to protect lives and keep commerce flowing during and after a Cascadia (megathrust) earthquake and tsunami.” The Plan and recommendations are due to be delivered to the Oregon Legislative Assembly by February 28, 2013.

Richard A. Reed, President Obama’s Senior Director for Resilience Policy, and Oregon Governor John Kitzhaber have acknowledged our resilience planning efforts and have provided their endorsement.

Resilience

Resilience as defined in House Resolution 3 means that Oregon citizens will not only be protected from life-threatening physical harm, but that because of risk reduction measures and pre-disaster planning, communities will recover more quickly and with less continuing vulnerability following a Cascadia Subduction earthquake and tsunami. OSSPAC defines the Cascadia earthquake to be a Magnitude 9.0 Cascadia Subduction earthquake with an average recurrence of once every 500 years.

To achieve the goal of rapid recovery, we need arrangements in place for government continuity, resilient physical infrastructure, and business/economic continuity. Resilient physical infrastructure is the foundation.

Resilience Planning Objective and Methodology

Oregon Seismic Safety Policy Advisory Commission (OSSPAC) will lead and coordinate with government agencies, academia, business and professional communities to develop a comprehensive 50-year resiliency plan so that the state will become a resilient state by 2062. It will work with various government agencies and advisory bodies to collect available studies and reports and develop data as appropriate to:

- assess **conditions** of existing critical facilities and lifeline systems,
- evaluate **effectiveness** of current design and construction practices relative to earthquake resilience,
- develop **desired performance targets** (in terms of usability and timeframe required for the restoration of services) to meet resilience goals, and
- prepare **recommendations** for statewide policies and actions to achieve the desired performance targets.

We will utilize concepts and ideas developed for San Francisco by the San Francisco Planning + Urban Research Association (SPUR) and by the Resilient Washington State initiative in our neighbor to the north, and apply them to a statewide level. The final SPUR documents for the Resilient City project in San Francisco can be found at http://www.spur.org/resilient_city.

To promote communication with the general public and policy makers, we will strive to use language appropriate for a general audience and minimize use of highly specialized technical vocabulary when developing the resilience plan.

Resilience Planning Organizational Structure

Oregon Seismic Safety Policy Advisory Commission (OSSPAC) will be leading and coordinating the preparation of the plan through its Resilient Oregon Steering Committee. OSSPAC Steering Committee consists of five commissioners as follows:

Kent Yu (Chair, Public member/Structural)
Jay Wilson (vice Chair, Public member/local government)
Althea Rizzo (OEM, State Earthquake/Tsunami Manager)
Ian Madin (DOGAMI)
Stan Watters (Public member/Utilities)

As a state commission with limited staff and resources at its command, OSSPAC must depend on voluntary assistance from Oregon's government agencies, academic, business, and professional communities to complete this task. OSSPAC has assembled one Advisory Panel and eight task work groups that represent a broad cross section of contributors, including policy advisors, government officials, emergency/business continuity managers, professors, engineers, scientists, business representatives, sustainability practitioners and others.

Advisory Panel

OSSPAC will seek strategic advice from the Advisory Panel throughout the development of the resilience plan. Its makeup is also intended to augment OSSPAC's overall capabilities and broaden OSSPAC representation from government, legislature, geographic region, and business.

The Advisory Panel currently consists of

Cameron Smith (Public Safety Advisor to the Governor)
The Hon. Peter Courtney/Ryan Mann (Oregon Legislature)
JR Gonzalez (Oregon PUC)
Bruce Johnson (ODOT)
Ed Dennis (Oregon Dept. of Education)
Yumei Wang (NEHRP)
Onno Husing (Oregon Coastal Zone Management Assn.)
Nate Wood, Ph.D. (USGS)
Scott Ashford, Ph.D. (OSU)
Chris Goldfinger, Ph.D. (OSU)
Andre LeDuc (U of O)
Jeff Soulages (Intel)
Edward Wolf (Oregon citizen)
Leon Kempner (Regional/Bonneville Power Administration)
Don Lewis (DOGAMI)
Jean O'Connor (Oregon Health Authority)

Eight Task Groups

OSSPAC Steering Committee has established eight task groups to address the state's critical facilities and its energy, water/wastewater, transportation, and telecommunications systems, mitigate tsunami risk, and enhance business continuity. The state's Department of Geology and Mineral Industries (DOGAMI) will support our work with mapped depictions of Cascadia earthquake scenarios based on the best available science.

Eight task groups are listed below:

1. Magnitude 9.0 Earthquake/Tsunami Scenario led by Ian Madin (OSSPAC/DOGAMI)
2. Critical/Essential Buildings led by Ed Quesenberry and Trent Nagele (SEAO)
3. Energy led by Stan Watters (OSSPAC/Port of Portland) and JR Gonzalez (PUC)
4. Telecommunications led by Althea Rizzo (OSSPAC/OEM) and Mike Mumaw (OSSPAC/Beaverton)
5. Transportation (Highways + Bridges/Ports/Railroads) led by Bruce Johnson (ODOT)
6. Tsunami Risk Mitigation led by Jay Wilson and Jay Raskin
7. Water and Waste Water System led by Mike Stuhr (PWB) and Mark Knudson (TVWD)
8. Business Continuity led by Susan Steward (OSSPAC/BOMA) and Gerry Williams (OSSPAC)

Magnitude 9.0 Earthquake/Tsunami Scenario Group will develop:

- Ground shaking intensity maps
- Tsunami Inundation maps
- Landslide and liquefaction maps

All other task groups will utilize the various maps developed to generate their resiliency plans. The task group makeup is expected to vary from one group to another due to the difference of the sectors. However, we expect each group to have at least one emergency manager, one engineer, and one business representative.

The Critical Building Task Group will address:

- Emergency Operations Centers
- Education facilities (K-12, College and University);
- Healthcare facilities (Hospitals and MOBs)
- Police and Fire Stations
- Critical government administration/services facilities
- Emergency sheltering facilities
- Community retail centers
- Financial/banking buildings
- Residential housing
- Vulnerable buildings (Un-reinforced masonry buildings and non-ductile concrete buildings)

The Energy Task Group will address the systems listed below:

- Electricity
- Natural Gas
- Liquid Fuel
- Alternative Energy – Solar, Wind and others
- Dams

The Telecommunications Task Group will address the systems listed below:

- Communication Network and Database
- Telecommunication Infrastructure

The Transportation Task Group will address the systems listed below:

- Bridges (owned by ODOT, Counties, or Cities)
- Airports and river and sea ports
- Railroads
- Mass Transit (Trimet)
- Columbia River

Tsunami Risk Mitigation Group will address the following:

- Tsunami evacuation
- Zoning and land use policy
- Critical facilities
- Re-building community
- Debris management

The Water and Wastewater Task Group will address the systems listed below:

- Drinking water storage, transmission, and distribution systems
- Wastewater collection systems and treatment plants

Interdependency issues among different lifeline sectors will be addressed through coordination of the steering committee and collaboration of Group leaders at a regular monthly meeting.

January 26, 2012 Kickoff Workshop

We will kick off the Oregon resiliency planning effort on January 26, 2012 (the 312th anniversary of the most recent Cascadia earthquake) at the Port of Portland.

We anticipate that the participants will get an overview of House Resolution 3 and the roadmap of the Oregon resilience plan, and learn about what Washington has accomplished with its Resilient Washington State initiative. During the breakout sessions, the leaders of each task group will facilitate and lead the discussion of the scope of their group, and work with their participants to develop action plans and schedules. Each task group will assign a designated participant to take notes, and the OSSPAC steering committee will assemble a final document based on information submitted by all workgroups. A second workshop will be scheduled in the fall of 2012 for each group to report their progress.



Oregon Resilience Planning Workshop

January 26, 2012
Port of Portland

Cascadia Subduction Zone Earthquakes

Turbidites show how much of the subduction zone ruptured in ~42 earthquakes over the last 10,000 years.



- 20 earthquakes ruptured all of the subduction zone.
- 2 to 3 earthquakes ruptured three quarters of subduction zone.
- 19 earthquakes ruptured the southern half or quarter of the subduction zone.



Acknowledgment

- ◆ Port of Portland for providing meeting venue
- ◆ CREW for sponsoring lunch
- ◆ Degenkolb for sponsoring morning coffee

Cascadia Earthquake Hazards and Risk

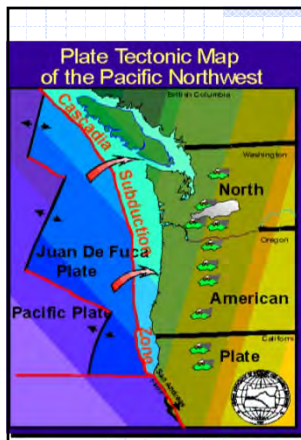

PACIFIC NORTHWEST

- ❑ Cascadia Subduction Zone
- ❑ 1994 – Oregon Building Code w/Seismic Design Provisions
- ❑ Interval 500 yrs for M9.0
- ❑ M9 on 1/26/1709

Seismic Concerns

- ◆ Progressive Government and community
- ◆ Unclear building performance
- ◆ Different standards for performance among different lifeline sectors
- ◆ Lack of inter-sector coordination
- ◆ Limited understanding by political leadership and the public of the potential performance of buildings and lifelines

House Resolution 3

70th OREGON LEGISLATIVE ASSEMBLY—2011 Regular Session

Enrolled House Resolution 3

Sponsored by Representative BOONE, Representatives COWAN, KRUEGER, ROBLAN, WITT, Senators COURTNEY, JOHNSON, KRUSE, YERGER, WHITSETT

- ◆ Protect citizens and businesses from shaking and tsunami
- ◆ Ensure rapid economic recovery

OSSPAC Mission

Broad Political Support

- ◆ Richard A. Reed, President Obama's Senior Director for Resilience Policy
- ◆ Oregon Governor John Kitzhaber
- ◆ State Agencies
- ◆ CREW, SEAO, ASCE, AIA
- ◆ Oregon businesses and local government
- ◆ Academia
- ◆ Neighbors, Friends and Colleagues

OSSPAC

- ◆ 18 members appointed by Governor
- ◆ Six representatives of government (Bldg Codes, DOGAMI, DLCD, OEM, ODOT, DOE)
- ◆ Six representatives of public interest (Legislature, Red Cross etc.)
- ◆ Six representatives of industry and stakeholders (Struct., Banking, local govern., multi-family, Bldg Owner, Utilities)
- ◆ The mission of OSSPAC is to increase or improve:
 - 1) earthquake awareness, education and preparedness;
 - 2) earthquake risk information;
 - 3) the earthquake safety of buildings and lifelines;
 - 4) geoscience and technical information; and
 - 5) emergency pre-disaster planning, response and recovery efforts

◆ <http://www.oregon.gov/OMD/OEM/osspace/osspace.shtml>

Agenda

Time	Event	Presenter
9:00 a.m.	Greeting and Introduction	Kent Yu, OSSPAC Chair Cali Ash, CREW President
9:20 a.m.	Introduction into Resiliency Planning in Oregon	General Caldwell/OR OEM, Rep. Deb Boone
9:40 a.m.	OSSPAC Mission Summary of House Resolution 3	Kent Yu
10:00 a.m.	Framework for Oregon Disaster Resiliency Plan	Kent Yu Jay Wilson, OSSPAC Vice-Chair
BREAK		
10:45 a.m.	Washington State Disaster Resiliency Plan	John Schalling, WA EMO
11:00 a.m.	Orientation of Task Force Breakout groups	Althea Rizzo, OR OEM Jay Wilson
12:00 a.m.	LUNCH	Pick up lunches
12:20 p.m.	Task Group Work Sessions	Facilitated by Task Group leads
BREAK		
2:45 p.m.	Task Group Briefings (6 minutes per group)	Presented by Task Group leads
3:00 p.m.	Next steps	Kent Yu
3:45 p.m.		
4:00 p.m.	End Workshop	

Oregon's Seismic Safety Legislation

- ◆ 2001 law "life safety" in schools by 2032
- ◆ 2002 Ballot Measure 15 amended Constitution: allows bonds to fix schools
- ◆ 2005 4 Bills (2007 schools report on web)
- ◆ 2007 Funds & staff establish grant program
- ◆ 2009 Seismic Retrofit Grant program
 - \$30 M (\$15M schools, \$15M emergency response facilities)
- ◆ 2011 Cascadia Resilience Planning

House Resolution 3

- ◆ Directs (OSSPAC) to “lead and coordinate preparation of an Oregon Resilience Plan that . . . makes recommendations on policy direction to protect lives and keep commerce flowing during and after a Cascadia (megathrust) earthquake and tsunami.”
- ◆ The Plan and recommendations to be delivered to the Oregon Legislative Assembly by February 28, 2013.

Resilience Planning Objective and Methodology

HR3 Resilience Definition

- ◆ Protect Citizens from physical life-threatening harm (from Earthquake and Tsunami)
- ◆ Community recover rapidly with less vulnerability through mitigation and pre-disaster planning
- ◆ Cascadia Earthquake is M9.0 with average 500 years return.

Resilience Planning Objective

- ◆ Look at 50-year time window
- ◆ Develop a comprehensive plan so that state is resilient by 2062
- ◆ Utilize concepts and ideas by SF Planning + Urban Research Association and from Resilient Washington Initiative

HR 3 Resilience Definition

- ◆ To Achieve Rapid Recovery, Require Government Continuity, Resilient Physical Infrastructure, Business Continuity
- ◆ Resilient Physical Infrastructure is the foundation

How Much Damage Can a City Endure?



Chile - 2010

New Zealand - 2011

The Resilient City

- A Resilient City can take “the Punch” of an event and through preparedness and the impromptu response of those affected, and recover quickly.
- Goal: Save the people, their neighborhoods, their cultural heritage and their local economy
- Resilience is sustainable

Transparent Hazard Definitions for the Region

Category	Hazard Level
Routine	Likely to occur routinely in the region (50/50)
Expected	Reasonably expected to occur once during the useful life of a structure or system (10/50, 500)
Extreme	Reasonably be expected to occur on a nearby fault (2/50, 2500)

SPUR Approach:

- Define concept of **resilience** in the context of disaster planning and recovery
- Establish **performance goals** for the “expected” earthquake that supports the definition of resilience
- Define transparent **performance measures** that help reach the performance goals
- Make **Recommendations** for new buildings, existing buildings and lifelines

Transparent Performance Measures for Buildings

Category	Performance Standard
Category A	Safe and operational: Essential facilities such as hospitals and emergency operations centers
Category B	Safe and usable during repair: “shelter-in-place” residential buildings and buildings needed for emergency operations
Category C	Safe and usable after repair: current minimum design standard for new, non-essential buildings
Category D	Safe but not repairable: below standard for new, non-essential buildings. Often used as a performance goal for existing buildings undergoing voluntary rehabilitation
Category E	Unsafe – partial or complete collapse: damage that will lead to casualties in the event of the “expected” earthquake - the killer buildings

Performance Goals for the “Expected” Earthquake

Phase	Time Frame	Condition of the built environment
I	1 to 7 days	Initial response and staging for reconstruction
II	7 to 60 days	Workforce housing restored – ongoing social needs met
III	2 to 36 months	Long term reconstruction

Lifelines and workforce are the key elements

Seismic Performance Life Safe and Operational



Seismic Performance Life Safe and Usable During Repair

Seismic Performance Unsafe (Collapse)

Seismic Performance Life Safe and Useable after Repair

Transparent Performance Measures for Lifelines

Category	Performance Standard
Category I	Resume 100% service within 4 hours
Category II	Resume 90% service within 72 hours 95% within 30 days 100% within 4 months
Category III	Resume 90% service within 72 hours 95% within 30 days 100% within 3 years

Seismic Performance Life Safe but not repairable

Target States of Recovery for Building & Infrastructure

Phase	Time Frame	Focus of Attention
I	1 to 7 days	Initial response and staging for reconstruction

EOC's,
City Buildings,
Hospitals,
Police and Fire Stations,
Shelters

Building Category A: "Safe and Operational"
Life Line Category I: "Resume essential service in 4 hours"

Target States of Recovery for Building & Infrastructure

Phase	Time Frame	Focus of Attention
II	7 to 30 days	Workforce housing restored – ongoing social needs met

Residential structures,
Schools,
Community retail centers,
Doctors offices



Building Category B: "Safe and usable while being repaired"
Life Line Category II: "Resume 100% workforce service within 4 months"

Oregon Resilience Planning Organizational Structure

Target States of Recovery for Building & Infrastructure

Phase	Time Frame	Focus of Attention
III	2 to 36 months	Long term reconstruction

Industrial Buildings
Commercial buildings
Historic buildings



Building Category C: "Safe and usable after repair"
Life Line Category III: "Resume 100% commercial service within 36 months"

Overall Structure

- ◆ OSSPAC
- ◆ OSSPAC Steering Committee
- ◆ Advisory Panel
- ◆ Eight Workgroups

Oregon Resilience Planning Steps

- ◆ assess **conditions** of existing critical facilities and lifeline systems,
- ◆ evaluate **effectiveness** of current design and construction practices relative to earthquake resilience,
- ◆ develop **desired performance targets** (in terms of usability and timeframe required for the restoration of services) — to meet resilience goals, and
- ◆ prepare **recommendations** for statewide policies and actions to achieve the desired performance targets.
- ◆ Recommendations will be prepared in plain, layman language.

OSSPAC Steering Committee

- ◆ Kent Yu (Chair, Public member/Structural)
- ◆ Jay Wilson (Vice Chair, Public member/Local government)
- ◆ Althea Rizzo (OEM, State Earthquake/Tsunami Manager)
- ◆ Ian Madin (DOGAMI)
- ◆ Stan Watters (Public member/Utilities)

Advisory Panel

- ◆ Cameron Smith (Public Safety Advisor to the Governor)
- ◆ The Hon. Peter Courtney/Ryan Mann (Oregon Legislature)
- ◆ JR Gonzalez (Oregon PUC)
- ◆ Bruce Johnson (ODOT)
- ◆ Ed Dennis (Oregon Dept. of Education)
- ◆ Yumei Wang (NEHRP)
- ◆ Onno Husing (Oregon Coastal Zone Management Assn.)
- ◆ Nate Wood, Ph.D. (USGS)
- ◆ Scott Ashford, Ph.D. (OSU)

Earthquake/Tsunami Group

- ◆ Led by Ian Madin (DOGAMI)
- ◆ Magnitude 9.0 Earthquake/Tsunami Scenario Group will develop:
 - 1) Ground shaking intensity maps
 - 2) Tsunami Inundation maps
 - 3) Landslide and Liquefaction maps

Advisory Panel (continued)

- ◆ Chris Goldfinger, Ph.D. (OSU)
- ◆ Andre LeDuc (U of O)
- ◆ Jeff Soulages (Intel)
- ◆ Edward Wolf (Oregon citizen)
- ◆ Leon Kempner (Regional/Bonneville Power Administration)
- ◆ Don Lewis (DOGAMI)
- ◆ Jean O'Connor (Oregon Health Authority)

Strong Shaking and Tsunami

- Strong Ground Shaking (M9 w/ 3 min shaking)
- Tsunami within 25 minutes



Eight Workgroups

- ◆ Magnitude 9.0 Earthquake/Tsunami Scenario
- ◆ Critical/Essential Buildings
- ◆ Energy
- ◆ Telecommunications
- ◆ Transportation
- ◆ Tsunami Risk Mitigation
- ◆ Water and Waste Water Systems
- ◆ Business Continuity

Liquefaction & Lateral Spreading

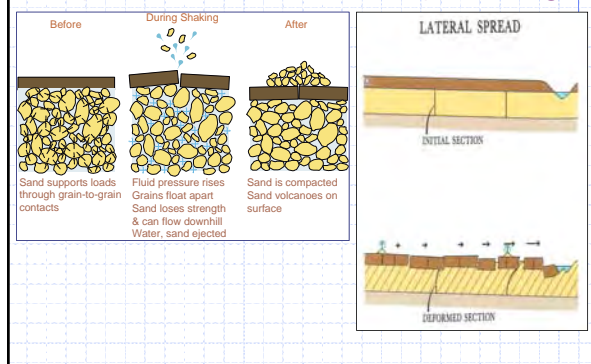

Liquefaction



Source: EERI, 2001

Lateral Load: Increased Seismic

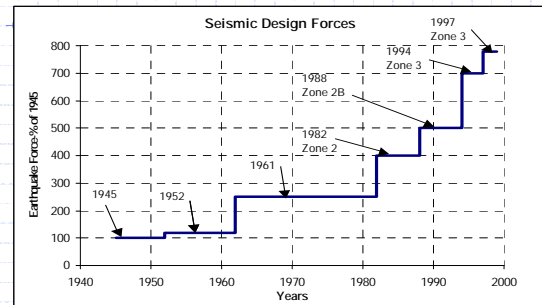

Lateral Spreading

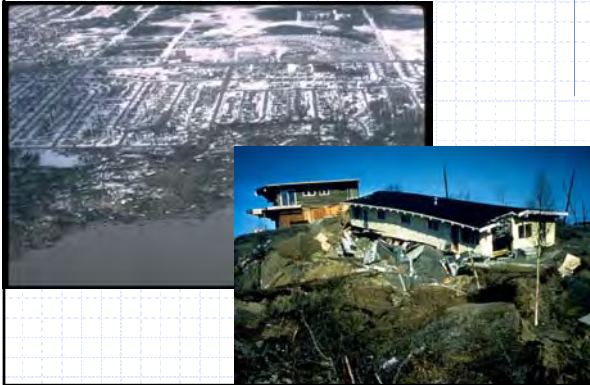

Oregon Education and Emergency Facilities

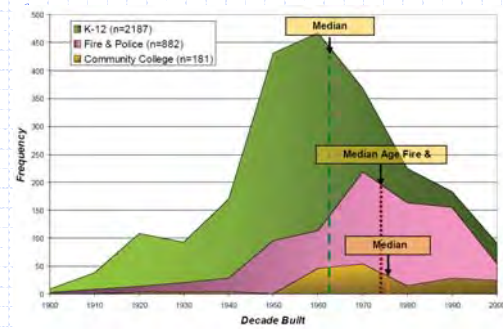

Critical Building Group

- ◆ Led by Ed Quesenberry and Trent Nagele (SEAO)
- ◆ The Critical Building Task Group will address the buildings listed below:
 - Emergency Operations Centers
 - Education facilities (K-12, College and University):
 - Healthcare facilities (Hospitals and MOBs)
 - Police and Fire Stations
 - Critical government administration/services facilities
 - Emergency sheltering facilities
 - Community retail centers
 - Financial/banking Buildings
 - Residential Housing
 - Killer buildings (URM and non-ductile RC buildings)

URMs and Non-ductile Concrete

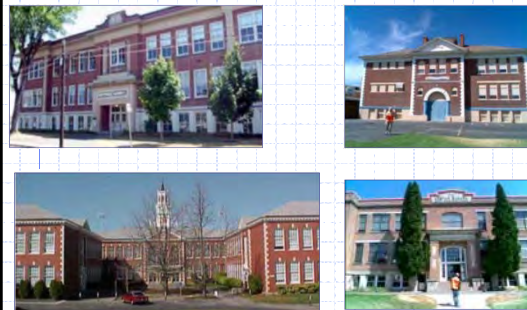

Energy Group

- ◆ Led by Stan Watters (OSSPAC/Port of Portland) and JR Gonzalez (PUC)
- ◆ The Energy Task Group will address the systems listed below:
 - Electricity
 - Natural Gas
 - Liquid Fuel
 - Alternate Energy – Solar, Wind and others
 - Dams

Transportation Group

- ◆ Led by Bruce Johnson (ODOT)
- ◆ The Transportation Task Group will address the systems listed below:
 - Bridges (owned by ODOT, Counties or Cities)
 - Airports and Seaports
 - Railroads
 - Mass Transit (Trimet)
 - Columbia River

Energy: Liquid Fuel, Electrical Systems



(Credit: Yumei Wang)

Tsunami Risk Mitigation Group

- ◆ Led by Jay Wilson/Jay Raskin
- ◆ Tsunami Risk Mitigation Group will address the following:
 - Tsunami evacuation
 - Zoning and Land use policy
 - Critical facilities
 - Re-building community
 - Debris management

Telecommunications Group

- ◆ Led by Mike Mumaw (OSSPAC/Beaverton) and Althea Rizzo (OSSPAC/OEM)
- ◆ The Telecommunication Task Group will address the systems listed below:
 - Communication Network and Database
 - Telecommunication Infrastructure

Water and Waste Water Group

- ◆ Led by Mike Stuhr (PWB) and Mark Knudson (TWWD)
- ◆ The Water and Wastewater Task Group will address the systems listed below:
 - Water storage, transmission, and distribution systems
 - Wastewater collection systems and treatment plants

Water and Wastewater



Project Schedule

Business Continuity Group

- ◆ Led by Susan Stewart (BOMA) and Gerry Williams (OSSPAC)
- ◆ Goals:
 - ◆ Raise Earthquake/Tsunami Awareness
 - ◆ Gauge Earthquake/Tsunami Preparedness
 - ◆ Gather input/ideas from Business for other workgroups to improve resilience plan

Project Schedule

- ◆ 100% Completion on February 2013
- ◆ 90% completion in December
- ◆ 75% completion in September 2012 (2nd Workshop)
- ◆ 45% completion in June 2012
- ◆ 15% completion in March 2012
- ◆ Kickoff workshop in January 2012 (Today)
- ◆ Initial Planning (11/2011 thru 1/12)

Oregon Resilience Planning Platform

- ◆ Virtual team with modern communication
- ◆ Online collaboration platforms (Box, Dropbox, Evernote...)

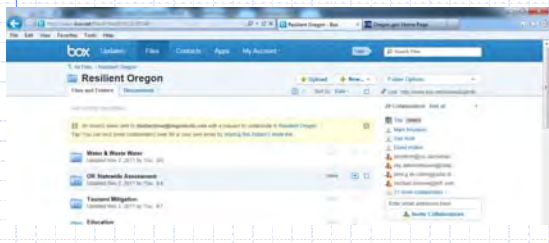

Next Steps

Next Steps

- ◆ Apply for funding in February 2012
- ◆ Special OSSPAC on February 21, 2012
- ◆ Invite Group Leaders to OSSPAC Meeting to discuss inter-dependency issues.

Reach Out

Thank You

**Resiliency Planning Task Groups
Work Session Orientation**

January 26, 2012

Jay Wilson
OSSPAC, Vice Chair

QuickTime™ and a
decompressor
are needed to see this picture.

Oregon Seismic Safety Policy Advisory Commission

**Resiliency Planning Task Groups
Work Session Orientation**

- How will the “final” document be synthesized and condensed from the work products produced from each group?
- A professional writer will work with each committee to develop the final report that will synthesize all of the different parts to form a unified document.

OSSPAC

**Resiliency Planning Task Groups
Work Session Orientation**

- Work sessions will be facilitated by team leads.
- Each group will have topics to initiate discussion at this breakout session.
-
- Session will be about 2 hours long.

OSSPAC

**Resiliency Planning Task Groups
Work Session Orientation**

- Will there be a uniform work product format that each group will be working from?
- OSSPAC Steering Committee will develop a template of specific issues that each committee must address as part of their work.
- The template will be used to maintain consistency of mission and format between committees.
- Mid year will be a 50% deadline.

OSSPAC

Task Groups and Leads

MAGNITUDE 9.0 EARTHQUAKE/Tsunami SCENARIO
led by Ian Madin (OSSPAC/DOGAMI)

CRITICAL/ESSENTIAL BUILDINGS
led by Ed Quesenberry and Trent Nagele (SEAO)

ENERGY
led by Stan Watters (Port of Portland) and JR Gonzalez (PUC)

TELECOMMUNICATIONS
led by Althea Rizzo (OEM) and Mike Mumaw (Beaverton)

TRANSPORTATION (HIGHWAYS + BRIDGES/PORTS/RAILROADS)
led by Bruce Johnson (ODOT)

Tsunami RISK MITIGATION
led by Jay Wilson/Jay Raskin

WATER AND WASTE WATER SYSTEM
led by Mike Stuhr (PWB) and Mark Knudson (TVWD)

BUSINESS CONTINUITY
led by Susan Steward (BOMA) and Gerry Williams (OSSPAC)

OSSPAC

**Resiliency Planning Task Groups
Work Session Orientation**

- Will we have access to administrative resources or other (State?) personnel to assist?
- There is no current funding for this effort. FEMA is going to be approached for assistance, but for now, each committee will be responsible for handling these responsibility as volunteers.

OSSPAC

Resiliency Planning Task Groups Work Session Orientation

- Are there funds/budget available? - Not yet.
- Other resources available and/or funds for reimbursable expenses (communication/conferencing, mailing, printing, travel, etc.) Kent Yu to investigate ways to obtain funding for reimbursement.
- Each committee will be directed to keep track of reimbursable expenses in the event that funding is found.

OSSPAC

Assigned Workgroups Business Roundtable

led by Susan Steward (BOMA) and Gerry Williams (OSSPAC)

Angell,	Townsend
Chamberlain,	Lori
Dodler,	John E.
Haapala,	Kurt
Herrenbruck,	Greg
Hynes,	Pat
O'Connor,	Jean
Reuter,	Scott
Sakamoto,	Ruby
Schamma,	Danny R.
Schwinghammer,	Michael
Shugrue,	Terry
Soulages,	Jeffery R.
Steidel,	Sam
Trimpler,	Sally
Van Dyke,	Rick
Ward,	Bryce
Weston,	Jim
Rodgers,	Mathew

OSSPAC

Box.net management

- Each Committee will have their own folder on Box.net.
- Each Committee will be responsible for maintaining the contents of their folder and keeping everything up to date.

OSSPAC

Assigned Workgroups Critical/Essential Buildings

led by Ed Quesenberry and Trent Nagele (SEAO)

Barbosa, André R.	
Bugni,	David
Duquette,	Shelley
Eggers,	Jennifer
Gehlen,	Joe
Johnson, Robert	
Kaplan,	Kevin
Monnier, Anne	
Richards, Josh	
Rippey,	Tim
Rogers,	Richard S.
Wolf,	Edward
Halog,	Tonya
Kumar,	Amit

OSSPAC

Resiliency Planning Task Groups Work Session Orientation

Oregon Public Meeting Law

Task Group leads should work closely with OSSPAC staff to meet State Requirements for proper notification of public meetings.

<http://www.oregon.gov/OMD/OEM/ossprac/ossprac.shtml>

ORS regarding public notice states "a reasonable time" of notice must be given, and special meetings just have to give at least 24 hours' notice.

A Bill was recently passed regarding posting all public meeting notices on The State's new "Transparency" state website. It lists all boards and commissions and all meetings. See link below.

http://www.oregon.gov/transparency/PublicMeetingNotices.shtml#Meeting_List_View

OSSPAC

Assigned Workgroups Energy

led by Stan Watters (Port of Portland) and JR Gonzalez (PUC)

Carter,	Rick
Ford,	Dave
Gonzales,	JR
Guerra,	Debbie
Wang,	Yumei
Watters, Stan	
Kempner Jr.,	Leon
Ridenhour,	Randy
Vranish,	Jack
Wilson,	Zamora
Karney,	Joe
Kuehnel, Andrea	
Plechinger,	John

OSSPAC

Assigned Workgroups
Telecommunications

led by Althea Rizzo (OEM) and Mike Mumaw (Beaverton)

Lumbard, Rizzo, Stember, Kelley	Devon Althea
---------------------------------------	-----------------

OSSPAC

Assigned Workgroups
Water and Waste Water

led by Mike Stuhr (PWB) and Mark Knudson (TVWD)

Ballantyne, Damewood, Doane, Knudson, Leon, Newell, Patterson, Perimon, Phelps, Schab, Stahl,	Don Mel James Mark Arturo Jim Sherry Todd Brad Rob Brian
---	--

OSSPAC

Assigned Workgroups
Transportation and Highways

led by Bruce Johnson (ODOT)

Ashford, EK-Collins, Libby, Merlo, Nako, Totten, Mabey,	Scott Greg Mark Carmen Albert Craig Matthew
---	---

OSSPAC

Assigned Workgroups
Tsunami Risk Mitigation

led by Jay Wilson (OSSPAC) and Jay Raskin (AIA)

Boone, Howard, Lucker, Raskin, Wilson,	Debbie Michael Stephen Jay Jay
--	--

OSSPAC

The Resilient Washington State Initiative

OSSPAC Meeting
January 26, 2012



Background

- The Resilient Washington State Initiative project is based upon the San Francisco Urban Planning and Research Association (SPUR) Report, entitled “*The Resilient City*”, which examines the current state of resilience to a scenario quake in San Francisco.
- Initial report includes 4 major policy sections - Defining Resilience, The Dilemma of Existing Buildings, Building it Right the First Time, and Lifelines.
- Three subsequent reports released during the course of the RWS project.



Presentation Overview

- Project Background
- “The Resilient Washington State Initiative”
- Project Approach & Preliminary Results
- A few early lessons learned... some considerations for Oregon



Target States of Recovery for Buildings & Infrastructure



So, what is the “Resilient Washington State Initiative”?



Incorporate Transparent Performance Measures

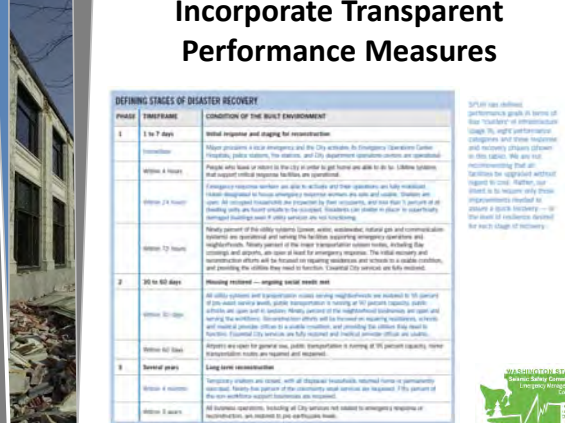



Resilient Washington State

- **Purpose** - Provide a framework for improving Washington's resilience when earthquakes occur.
 - Framework includes more effective seismic mitigation policies and recommendations for legislation and policy changes to improve and enhance statewide seismic safety.
- **Timeframe** – Goal of making the state resilient in 50 years.
 - Implementation plan by short-, mid-, long-term



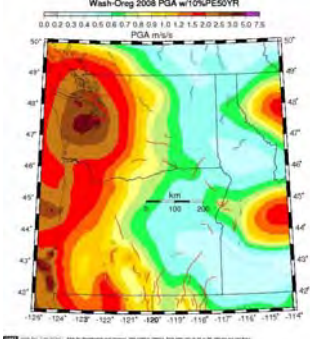

Resilient Washington State

Resilient Washington State

Earthquake Hazard:

- Not possible to define single EQ scenario at a State level.
- Identified a suite of scenarios from the 20 scenario earthquakes developed in 2009 by personnel from the WA EMD, WA DNR, USGS, and FEMA for use in planning efforts.

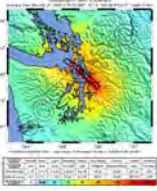
So, what *IS* resilience?



Resilient Washington State

Earthquake Hazard:

- M7.2 Seattle Fault, M7.4 Southern Whidbey Island Fault, M7.1 Tacoma Fault, M7.3 Saddle Mountain Fault, M6.8 Cle Elum Fault, and M9.0 Cascadia.
- Scenarios define geographic area of impact.
- Consider Ground Motions consistent with USGS 10/50 PGA maps.



Defining Resilience



- SPUR uses engineering standards –how many building demolitions (or infrastructure failures), and how long a recovery time for various levels of EQ.
- Resilience as a disaster, but not a catastrophe.
- Ability to recover – govern, lifelines to resume in short time frame, people stay in homes, resume normal living routine in weeks and return to new “normal” in few years.







RWS Definition of Resilient State

- **A resilient state is one that maintains services and livelihoods after an earthquake. In the event that services and livelihoods are disrupted, recovery occurs rapidly with minimal social disruption and results in a new and better condition.**



RWS Definition of Resilient State

- Environmental Protection – The natural resources and ecosystems of Washington State should be managed in such a way as to minimize earthquake-induced damage. This includes the use of proper growth management, accident response capacity, and industrial safety measures.



RWS Definition of Resilient State

- Property Protection – Public and private property within the State of Washington should be built, retrofitted, or rebuilt to minimize earthquake-induced damage. This includes proper design and construction of both structural and non-structural elements.



RWS Definition of Resilient State

- Life Safety and Human Health – Residents of the State of Washington should not suffer life-threatening injuries from earthquake-induced damage or develop serious illness from lack of emergency medical care after an earthquake. This includes enforcing and updating building codes, eliminating non-structural hazards, and ensuring continuity of emergency health care.

RWS Definition of Resilient State

- Economic Security – Residents and businesses within the State of Washington should have access to income opportunities to meet basic needs before and soon after an earthquake. This includes sufficient employment opportunities, market access, distribution capacity, and supplier access.



RWS Definition of Resilient State

- Community Continuity – All communities within the State of Washington should have the capacity to maintain their social networks and livelihoods after an earthquake disaster. This includes prevention of social-network disruption, social discrimination, and community bias.



Overall Project Approach

- Established RWS Subcommittee under WA SSC
- Reviewed existing information and incorporated new data from the USGS/ DNR/EMD Scenario Catalog Project as a starting point.
- Hosted a workshop engaging key stakeholders and local jurisdictions in the process.
 - A truly Resilient State is made up of Resilient cities, counties, & tribes - local jurisdictions can adopt this approach (i.e. San Francisco model) at a smaller scale.

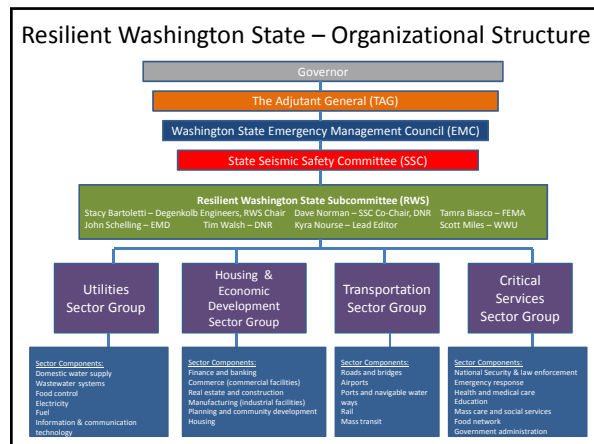
Overall Project Approach (cont.)

- Conducted an online survey of subject matter experts to help identify current capabilities
- Established formal Sector Groups with subject matter expert co-leads to facilitate information gathering from key partners and obtain buy in.
 - Sector Groups work independently using common guidance
- Hosted a follow-up workshop to deconflict results and review interdependencies
- RWS Subcommittee provides report



Resilient Washington State

Objectives of Sector Groups:

- Evaluate the current condition Sector and assess how quickly they can be restored.
- Develop targets for the desired restoration time frame.
- Define the vulnerabilities and key interdependencies.
- Prepare recommendations for statewide action to achieve desired targets.



Resilient Washington State Sectors

- Critical services
- Housing and economic development
- Transportation
- Utilities

Each sector is comprised of multiple possible components

Each sector has different restoration capacity & targets with respect to each RWS value

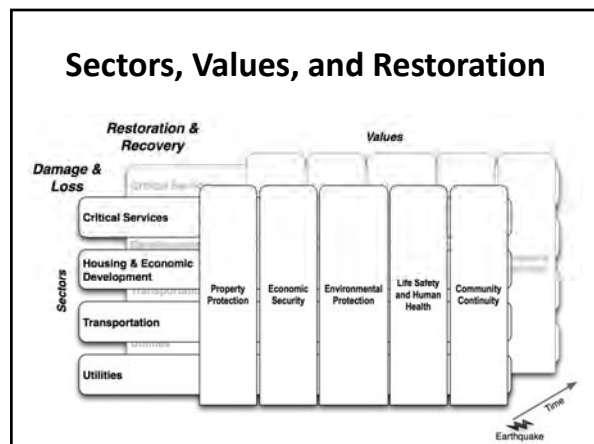

Resilient Washington State

Process and Timing:

- 2009 – RWS Committee Formed
- 2010 – RWS Committee Developed Framework
- 9/17/2010 – Stakeholder Workshop to form Sector Groups
- 12/2/2011 – Concluding Workshop
- Q1 2012 – Draft Report
- Q2 2012 – Final Report



- Questions?



A few early lessons learned:

- Planning for multiple scenarios at a state level is TOUGH!
 - Consider examining one at a time
 - Leverage FEMA-State Cascadia planning process & data
- Tables as tools, not products
 - Consider having a starting draft and have the experts ‘tell you where you’re wrong’ to keep out of the weeds
- Mitigation vs. Response
 - Interconnected, but what is your goal? Which one is the priority for your planning?



So, what does ‘being resilient’ mean to Oregon?

Registration for Jan 26, 2012 Workshop

Lname	Fname	Affiliation
1 Angell	Townsend	Reed College
2 Ashford	Scott	OSU
3 Ballantyne	Donald	Degenkolb Engineers
4 Barbosa	André R.	OSU
5 Barrett	Denise A.	Portland Bureau of Emergency Management
6 Behrandt	Steve	City of Portland - BES
7 Bela	James	Oregon Earthquake Awareness
8 Boone	Deborah	Oregon House of Representatives
9 Bugni	David	David Bugni & Associates
10 CARTER	Rick	Oregon Public Utility Commission
11 Caswell	Heide	PacifiCorp
12 Chamberlain	Lori	Oregon Bankers Association
13 Damewood	Mel	Eugene Water & Electric Board
14 Dennis	Ed	OR Dept of Education
15 Dills	Kimberly	OHA/CDC
16 Doane	James	Public member
17 Dodier	John E.	Portland VA Medical Center
18 Downing	Shane	OR Army National Guard
19 Duquette	Shelley	City of Portland
20 Eggers	Jennifer	Degenkolb Engineers
21 EK-Collins	Greg	Oregon Department of Transportation
22 Estenes	Patrick	The Standard Insurance Company
23 Ford	Dave	Portland General Electric
24 Gehlen	Joe	Kramer Gehlen
25 Gonzale	JR	PUC
26 Guerra	Debbie	Pacific Power
27 Haapala	Kurt	AIA President
28 Halog	Tonya	J.G. Pierson
29 Herrenbruck	Greg	New Seasons Market
30 Howard	Michael	Oregon Partnership for Disaster Resilience
31 Hynes	Pat	Knife River Prestress Division
32 Johnson	Robert	Johnson Broderick Engineering, LLC
33 Kaplan	Kevin	VLMK
34 Karney	Joe	NW Natural
35 Kempner Jr.	Leon	Bonneville Power Administration
36 Knudson	Mark	Tualatin Valley Water District
37 Kuehnel	Andrea	NW Natural
38 Kumar	Amit	City of Portland BDS
39 Le Duc	Andre	UO
40 Leon	Arturo	Oregon State University
41 Libby	Mark	HDR Engineering, Inc.
42 Lucker	Steve	Oregon Dept. of Land Conservation and Development
43 Lumbar	Devon	Degenkolb Engineers
44 Maass	Matthew	Oregon Dept of Aviation
45 Mabey	Matthew	Oregon Dept. of Transportation
46 Madin	Ian	DOGAMI/OSSPAC
47 Male	James	University of Portland
48 Merlo	Carmen	Portland Bureau of Emergency Management
49 Monnier	Anne	KPFF Consulting Engineers
50 Mumaw	Michael	OSSPAC/ City of Beaverton Emergency management
51 Nagele	Trent	VLMK
52 Nako	Albert	Oregon Department of Transportation - Bridge Section
53 Newell	Jim	Degenkolb
54 O'Connor	Jean	Oregon Heath Division
55 Patterson	Sherry	Board Member, Rivergrove Water District, Lake Grove FD

56 Paul	Willy	Kaiser Permanente
57 Perimon	Todd	AECOM
58 Phelps	Brad	CH2M
59 Plechinger	John	Pacific Power
60 Pynch	Allison	American Society of Civil Engineers Technical Committee on Lifeline Earthquake Engineer
61 Quesenberry	Ed	Equilibrium Engineers LLC
62 Raskin	Jay	Ecola Architects, PC
63 Reuter	Scott	Oregon VOAD
64 Richards	Josh	KPFF
65 Ridenhour	Randy	Bonneville Power Administration
66 Rippey	Tim	TM Rippey Consulting Engineers
67 Rizzo	Althea	Oregon Emergency Management
68 Rodgers	Mathew	OSU Emergency Management
69 Rogers	Richard S.	Oregon Building Codes Division
70 Schab	Rob	Coos Bay/North Bend Water Board
71 Schamma	Danny R.	Liberty Northwest
72 Schwinghammer	Michael	Wells Fargo
73 Shugrue	Terry	Turner
74 Soulages	Jeffery R.	Intel
75 Spangler	Matthew	DLCD/OCMP
76 Stahl	Brian R.	City of Gresham, OR
77 Steidel	Sam	Cannon Beach
78 Stember	Kelley	Sprint Nextel
79 Steward	Susan	BOMA Oregon
80 Stuhr	Michael	Portland Water Bureau
81 Subramanian	Laxman	Standard Insurance Company
82 Thompson	Jason	KPFF
83 Totten	Craig	KPFF CONSULTING ENGINEERS
84 Trimpler	Sally	Bank of America
85 Van Dyke	Rick	Cambia Health Solution
86 Vranish	Jack	PacifiCorp
87 Wang	Yumei	DOGAMI (NEHRP)
88 Ward	Bryce	Econorthwest
89 Watters	Stan	Port of Portland
90 Weston	Jim	PeaceHealth Sacred Heart
91 Wieber	Michael	NW Seismic Retrofit
92 Williams, Jr.	Gerald H.	Construction Research, Inc.
93 Wilson	Zamora	NW Natural
94 Wilson	Jay	Vice-Chair, OSSPAC
95 Winchester	Jeffery R.	City of Salem
96 Wolf	Edward	Member, Advisory Committee on Long-Term Facilities Planning, Portland Public Schools
97 Woolley	Iaren	DLCD/OCMP
98 Yu	Kent	Chair, OSSPAC

Did not attend but expressed interest

Johnson	Gwynn R.	Portland State University
Swecker	Mitch	Director, Oregon Department of Aviation
Cruz	Tony	Worksafe Technologies
Newnam	Al	Ore. Dept. of Community Colleges and Workforce Development
Little	Christie	
Sieck	Cliff	Hewlett Packard Co.
MCCULLOUGH	NASON J.	CH2M HILL
Ianni	Francisco	Director of Preparedness, American Red Cross

contact for interest

Floyd	Anita	CenturyLink
Trullinger	Ron	CenturyLink

Cooley
Mulder
Willer
Murray
Wolf

Doug
Joe
Renee
Cathy
Brant

Comcast
Comcast
Frontier Communications
Integra Telecom
Oregon Telecommunications Association

Appendix III October 5, 2012 Workshop

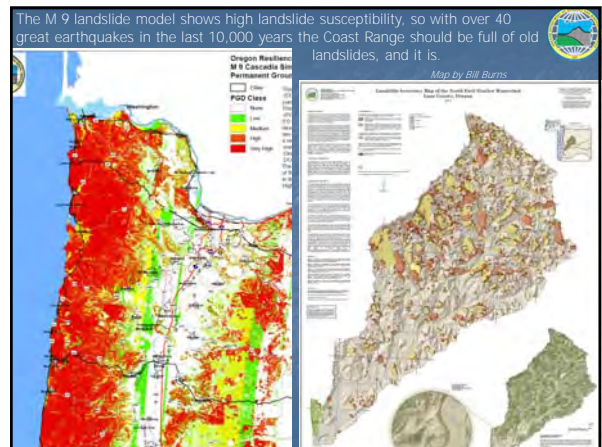
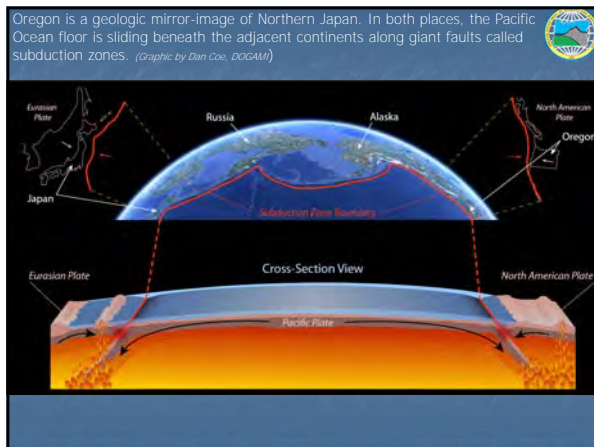
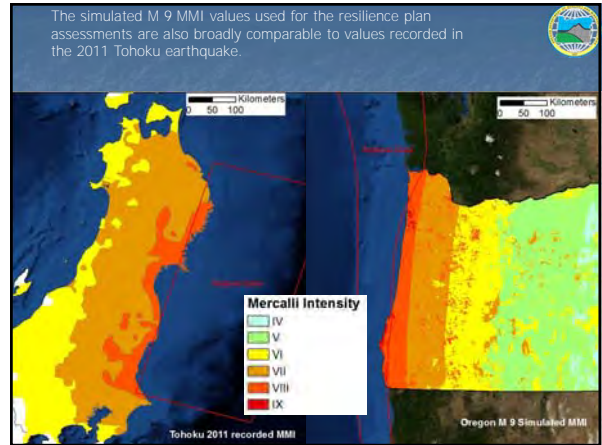
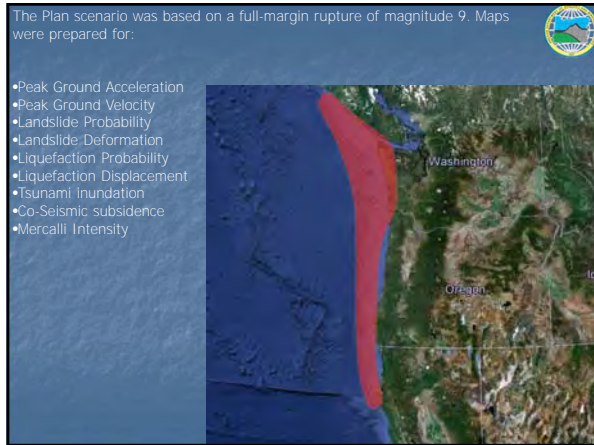
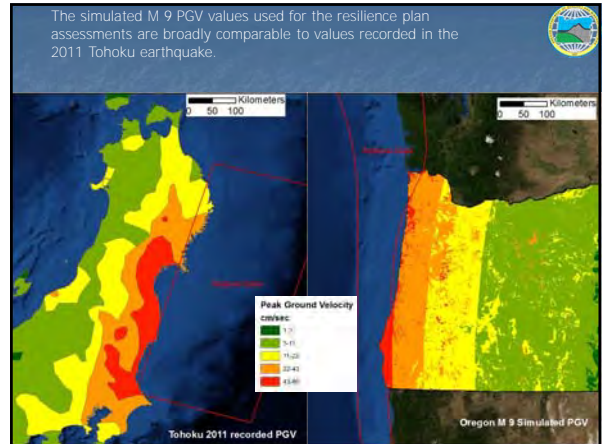
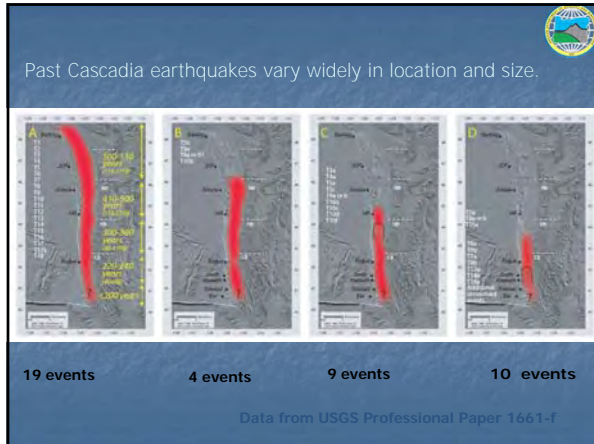

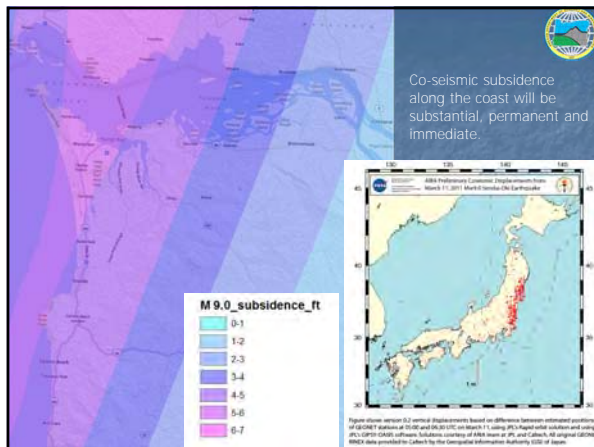
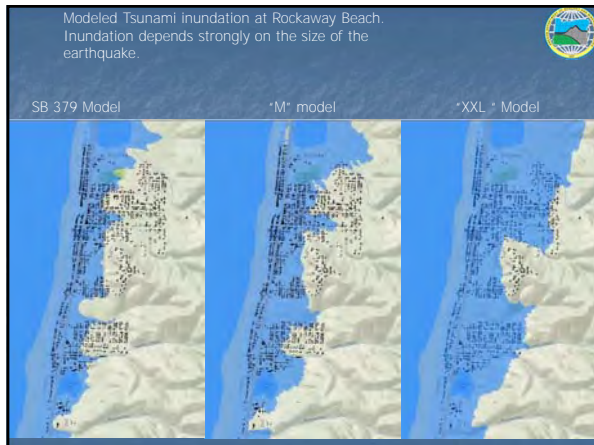
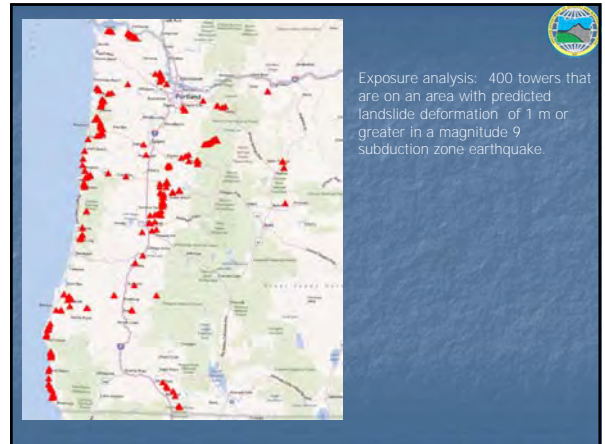
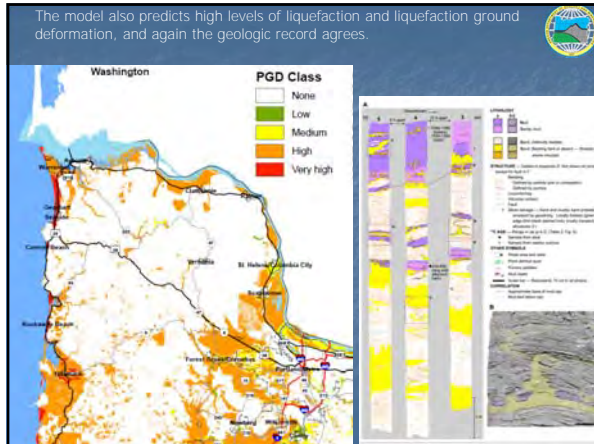

Business/Community Continuity

Business/Community Continuity

Transportation and Utilities*

Transportation (highways, rail, light rail, bus, ports and airports): 7

Utility systems (potable and wastewater, natural gas, oil, electric power and communications): 6

Highway kilometers: 11,289

Bridges: 3,057

Pipe: 511,182

*Hazus-MH. Earthquake Event Report. Print Date: April 12, 2012

Business/Community Continuity

1,425,000 BUILDINGS (Oregon)*

Total Residential: 1,296,750

Total Commercial: 128,250

*Hazus-MH. Earthquake Event Report. Print Date: April 12, 2012

Business/Community Continuity

Total Office SF

Northwest Commercial Building Stock Assessment
Prepared for the Northwest Energy Efficiency Alliance. December 1, 2009

Size (1,000 sf)	Office %	# of Buildings	Percentage
< 5	8.5	7,759	43.4
5 - 19	20.10	7,057	39.5
20 - 49	13	1,695	9.5
50 - 99	12	730	4.1
100 - 499	34.70	528	3.0
>= 500	11.7	107	.6
Total	100	17,876	100

Business/Community Continuity

Essential Facilities*

Hospitals: 1,124 Emergency Operations Centers: 8

Schools: 1,574 Dams: 680

Fire Stations: 334 High hazard dams: 108

Police Stations: 273 Hazardous materials sites: 829

*Hazus-MH. Earthquake Event Report. Print Date: April 12, 2012

Business/Community Continuity

Commercial Building Damage

Earthquake Hazard Report: April 9, 2012

Commercial	None	Slight	Moderate	Extensive	Complete	Total
Metro Region	6,759	10,106	12,270	4,647	461	34,242
Outside Metro	14,333	7,596	11,878	7,904	3,072	44,785
Total	21,092	17,702	24,148	12,551	3,533	79,027

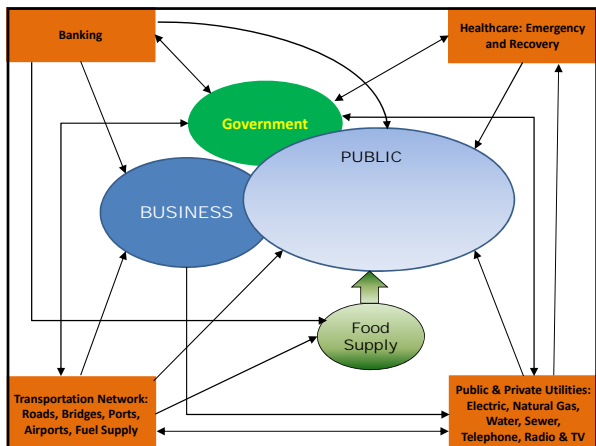

Business/Community Continuity

The State does not have policies that assure a level of resiliency, emergency response and recovery are in place and actively maintained for the state, county, city and businesses.

Recommendations:

- Require all county and city Emergency Operations Centers (EOC) to establish a Business BEOC function, web site and staff position that are coordinated at the State level by the State's BEOC function to provide local support to businesses for resiliency, response and recovery activities.
- Require all state, county, and city departments have annual reviews/exercises of Continuity of Operations Plans (COOP) in place.
- Offer eBRP toolkit at no cost to businesses larger than 10,000 square feet or 25 number of employees. This information must be available to the private sector, upon request at no charge.
- Offer training for all communities, prioritizing communities in a high-risk area (Oregon Coast, etc.).
- Require all business licensed in Oregon to certify during the licensing process that they have emergency response and business continuity plans.
- Establish a state program to provide for ATC 20 Certified inspectors. State assumes cost/risk/liability for state sponsored/trained inspectors. State also provides liability protection for business owners from contractor's erroneous good faith estimates.
- Require business certifications for out of state business coming to provide recovery support.

Business/Community Continuity

The Business /Community Continuity Sub-Committee (BCC) approached the 50 year preparedness goal for businesses and workforce by dividing the effort into three main areas:

- Resiliency – what can be done now to help businesses prepare for, recover from and remain in Oregon at the state, county, city and business levels after an event?
- Emergency Response – what can the state, county, city and the businesses do to respond to an event to minimize the impact to businesses' physical assets, supporting infrastructure and workforce; allowing business to resume activity in the shortest possible time?
- Recovery - what can the state, county, city and the businesses do to facilitate their economic recovery?

Business/Community Continuity

Uncertainty about how businesses will respond during an earthquake.

Recommendations:

- Identify all buildings greater than 10,000 square feet that they expect will survive a major event. State will create and maintain a public database of all critical buildings, locations of emergency shelters, etc. Included in the database will be the status of risk areas including stable electrical power, reliable communications, logistics: rail, airport, roadways, water ways, water & sanitation; and waste disposal.
- Provide resources to help building owners seismically upgrade their asset(s). State to act as a "clearing house" for seismic funding options including: tax reduction incentives; federal and state grants, or low interest loans; state to ensure a timely business recovery loan process. (Consider resources such as the Small Business Administration disaster loans for businesses following an event).
- Work with the Building Codes Division (BCD) to require all buildings greater than 50,000 square feet to have gas piping to be equipped with a gas shutoff valve.

Business/Community Continuity

Sub-Committee Findings

- The State does not have policies that assure a level of resiliency, emergency response and recovery are in place and actively maintained for the state, county, city and businesses
- Uncertainty about how businesses will respond during an earthquake
- The State needs to align its resiliency, emergency response and recovery plans with the Department of Homeland Security's Critical Infrastructure Sectors to assure coordination planning/response for natural disasters and terrorist attacks

Business/Community Continuity

The State needs to align its resiliency, emergency response and recovery plans with the Department of Homeland Security's Critical Infrastructure Sectors to assure coordination planning/response for natural disasters and terrorist attacks.

Recommendations:

- Use the 18 Critical Infrastructure Sectors: Food & Agriculture; Banking & Finance; Chemical, Commercial Facilities; Communications; Critical Manufacturing; Dams; Defense Industrial Base; Emergency Services; Energy; Government Facilities; Healthcare & Public Health; Information Technology; National Monuments & Icons; Nuclear Reactors; Materials & Waste; Postal & Shipping; Transportation Systems, and Water, to list all related companies in Oregon and require them to certify they have emergency response and business continuity plans in place and are exercised or used annually.
- State to use the Business EOC (BEOC) function to coordinate the command, control and communications (C3) of the listed companies for providing evidence of certification, exercising and event response. Require all critical infrastructure companies to register with their local BEOC's and provide business and emergency contact information of their senior operations personnel.
- Legislature to mandate that cities throughout Oregon provide a risk assessment of their major lifelines, develop clear instructions for citizens how to evacuate the city, and develop a plan to transport workers and emergency supplies necessary for recovery.

Oregon Resilience Plan Coastal Resilience Workgroup

Advisory Panel Meeting
October 5, 2012

Jay Wilson
OSSPAC, Vice Chair



Oregon Seismic Safety Policy Advisory Commission

Cascadia Planning Map

- Planning Zones**
1. Central Oregon
 2. I-5/Willamette Valley
 3. Coast EQ Affected Zone
 4. Coast Tsunami-Affected Zone

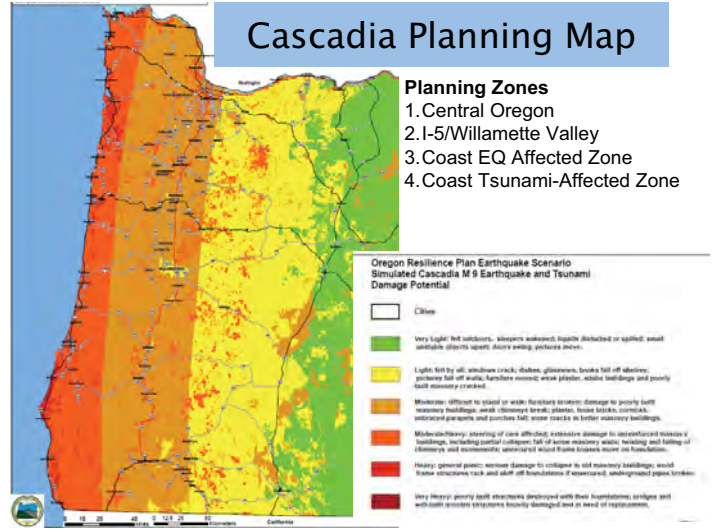

Coast – Most Significant Issues

- **Comprehensive Approach for Life Safety**
 - Evacuation and shelter for people displaced
 - Short-term and long-term housing
- **Target for 90% Restoration of Services in Two Weeks – Reasonable? Possible?**
 - Greatest immediate and long-term needs for assistance in the State (per capita).
 - Interdependency between Tsunami and EQ Zones
 - Weather-dependent capabilities?
- **Mitigation, Recovery and Reconstruction**
 - Land use guidance for community relocations
 - Return of Community Economic Base
- **Debris Management**

Tsunami Life Safety

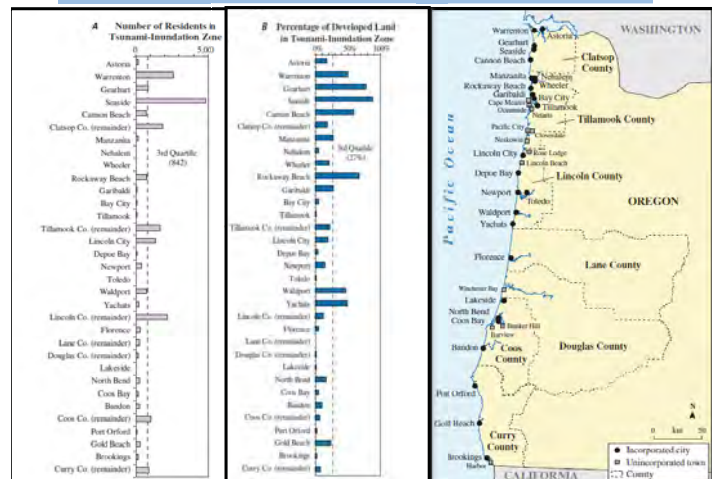

Tsunami Destination

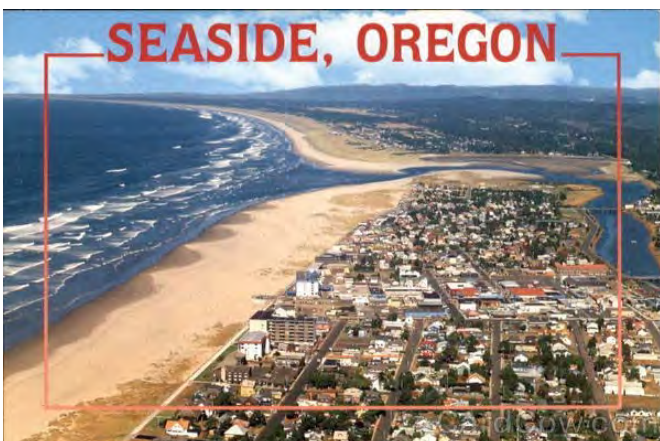

Tsunami Destination - Depot Bay



Tsunami Destination - Newport



Tsunami Destination - Florence



©2010
SKY-VIEW Photography

Tsunami Destination - Winchester Bay



Tsunami Destination - North Bend



Aerial View of North Bend, Oregon

CardCow.com

Tsunami Destination



Tsunami Destination - Gold Beach

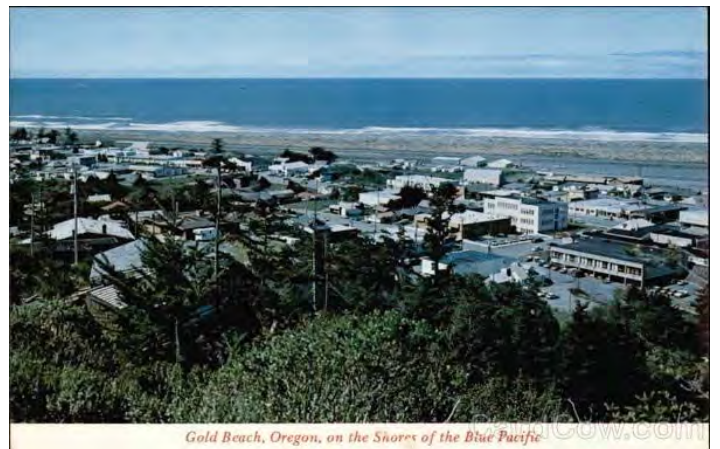

Gold Beach, Oregon, on the Shores of the Blue Pacific

CardCow.com

Earthquake vs. Tsunami Zone



Minamisanriku Tsunami Zone - Zero Capacity



Most Significant Issues

- Expected Recovery Timeline of 90% Services?

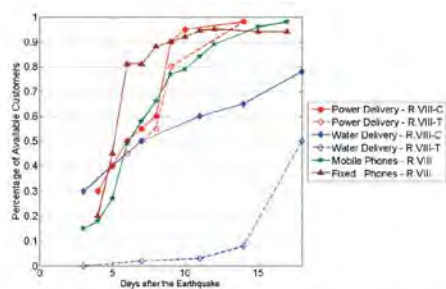

Empirical restoration times for power delivery, water distribution, and telecommunications. The letters C and T indicated the cities of Concepción and Talcahuano, respectively. Both cities are in Region VIII, whose capital is Concepción.

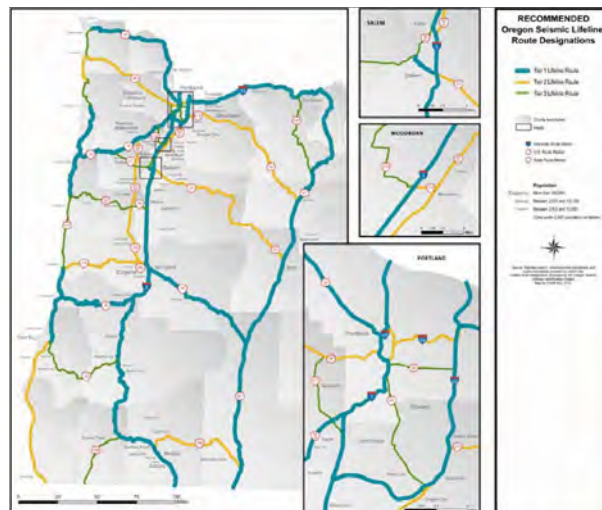

Debris Management



Coastal communities will likely have restrictions on readily available land within their jurisdictional boundaries and grapple with environmental concerns about disposing of tens of thousands of tons of debris – with much of it possibly contaminated.

Reconstruction and Recovery

Policy arrangement for realizing reconstruction goal

~ Protecting Lives, Living with the Sea and the Earth, Creating Home Town Iwate, Sanriku ~



Relationship Between Sustainability and Disaster Resilience





Source: Public Entity Research workgroup

OSSPAC

ENERGY TASK GROUP



Electric
Natural Gas
Liquid Fuel

The Risks by Sector

- Liquid Fuels Delivery Systems
 - the liquid fuel transmission pipeline
 - Liquid fuel pipeline was largely constructed in the 1960s when the regional seismic hazards were unknown and state-of-practice construction techniques at that time did not include any reference to seismic standards
 - marine vessels
- Storage – The bulk in tank Farms



Earthquake/Tsunami Scenario

- 4 Distinct Regions
 - Coastal Tsunami
 - Coastal Non-Tsunami
 - Valley
 - Eastern Oregon
- Oregon's critical energy infrastructure (CEI) are not governed by a uniform set of design and construction codes
 - Much of the existing CEI has been constructed with severe seismic design deficiencies
 - New critical infrastructure is often constructed without adequate seismic provisions
 - To minimize extensive direct earthquake damage, substantial improvements to the CEI are necessary

The Risks by Sector

- Shipping channel
 - The navigational channel from the Columbia River mouth to the lower Willamette River is used to transport fuel by marine vessels
 - The Columbia River mouth is expected to have tsunami damage and the channel is expected to experience slope failure, which would close the channel to traffic
 - It is possible that bridges and other river crossings, such as buried gas pipelines and electrical crossings, would be damaged and temporarily block the waterway
 - The regional seismic hazards are now known to be significant and the soils at the river crossings are susceptible to liquefaction and lateral spreading
 - Closure of the shipping channel would prevent marine vessels from delivering liquid fuel as well as emergency response and recovery equipment from being delivered



CSZ Resiliency - Today

The Four Regions

- Tsunami Impacted Coastal areas
- Tsunami Not-Impacted Coastal areas
- Valley
- Eastern Oregon

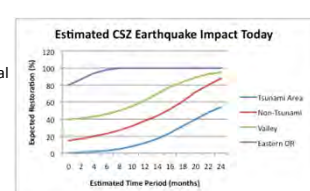

Recovery Timeframe Graphical Representation

Impact of a CSZ earthquake today for each of the 4 regions, with the exception of Eastern Oregon, would be catastrophic!

The Risks by Sector

- Marine terminals
 - All of the port facilities in the CEI Hub have significant seismic risks due to liquefaction, lateral spreading, and seiches
 - Some older piers were constructed without any seismic protection, have deteriorated, and are likely to fail in even a moderate earthquake
 - If oil products are released and contaminant the navigable waterway, the waterway may be closed to river traffic thus impeding emergency response activities as well as the supply chain
 - The local capacity to fight fires and clean hazardous material spills is limited.

The Risks by Sector



- Fuel supply
 - Only three existing tanks are known to have addressed liquefaction vulnerabilities
 - The fuel terminals in the CEI Hub on average have a three to five day supply in the tank farms for regular unleaded gasoline and diesel fuel
 - Premium gasoline is subject to the daily delivery and heavily dependent on whether the intercompany pipeline on Front Avenue is operational
 - If the supply chain is disrupted by pipe breaks north of the CEI Hub and closure of the shipping channel to the west, fuel would quickly become scarce
 - Options to transport fuel from the east and south and by air are very limited.

The Risks by Sector



- Electricity
 - The bulk of the electrical networks were not built to withstand moderate to significant earthquakes
 - Electrical facilities and systems have significant seismic risk due to ground shaking and ground failure, including liquefaction and lateral spreading
 - Seismically vulnerable facilities include substations, Switch Stations, transmission lines, power plants, and key distribution substations
- CSZ damage to the western electrical grid will likely result in grid blackout
- BPA is the only transmission operator that has taken seismic vulnerability seriously

The Risks by Sector



- Portland International Airport (PDX)
 - PDX airport receives 100 percent of their liquid fuels from a terminal in the CEI Hub
 - PDX has a limited on-site fuel supply
 - If the pipeline between the CEI Hub and PDX fails, then PDX would likely experience a shortfall and operations would be impacted.

Impacts to Oregon

- Based on visual observations, engineering judgment, limited analyses, and limited information from the facility operators, and available literature, significant seismic risk exists in the CEI
- Some critically important structures appear to be susceptible to significant damage in a major earthquake with catastrophic consequences
- Multiple liquid fuel transmission pipe breaks and natural gas transmission pipe breaks are possible
- Damage to liquid fuel, natural gas, and electrical facilities will occur.
- The waterway would likely be closed and require clean up.

The Risks by Sector

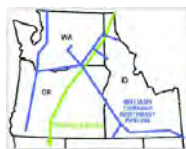

- Natural Gas
 - Oregon's largest natural gas service provider receives the majority of their natural gas from pipelines that cross under the Columbia River both near Sauvie Island and also between Washougal, Washington and Troutdale, Oregon
 - One of the natural gas pipelines crosses under the Willamette River at Multnomah Channel near their gate station at the southern end of Sauvie Island
 - The soils at these river crossings are subject to liquefaction and lateral spreading
 - The natural gas company's storage capacity is limited and pipe breaks could lead to a natural gas shortfall in the state as well as explosions or fires.

Impacts to Oregon

- Due to a combination of the existing seismic hazards, vulnerability of the exposed infrastructure and potential consequences, Cascadia earthquakes pose substantial risk to the CEI in Oregon
- Not only are the energy sector facilities dependent on other sectors and systems, including transportation and communication, they are interdependent upon each other
- A major Cascadia earthquake and tsunami would likely produce an unprecedented catastrophe much larger than any disaster the state has faced.
- Western Oregon will likely face an electrical blackout, extended natural gas service outages, liquid fuel shortage, as well as damage and losses in the tens of billions of dollars in a future major Cascadia earthquake
- Preparing for a catastrophic disaster to become more resilient is needed to improve personal safety and security, and safeguard communities and businesses.

Recommendations

- Energy sector companies should conduct **Seismic Vulnerability Assessments** on all of their systems or facilities, and should work with the appropriate local, state, tribal and federal government agencies and stakeholders to achieve timely completion of the assessments to understand existing vulnerabilities.
- Energy sector companies should institutionalize long-term **seismic mitigation programs**; and should work with the appropriate local, state, tribal and federal government agencies and stakeholders to achieve timely and effective mitigation to ensure facility resilience and operational reliability.

CSZ Resiliency in 50 years

The Four Regions

- Tsunami Impacted Coastal areas
- Tsunami Not-Impacted Coastal areas
- Valley
- Eastern Oregon

Recommendations

- The State of Oregon's **Homeland Security Council or OPUC** should be given the authority to review the vulnerability and resilience of the energy sector to earthquakes and other natural disasters within the scope of their mission.
- Energy sector companies and the State of Oregon should **build Oregon's seismic resilience** to a Cascadia earthquake.
 - Adopting pro-active practices and a risk management approach will help achieve seismic resilience. Encouraging a culture of awareness and preparedness concerning the seismic vulnerability of the energy sector including long range energy planning should be conducted.

Policy Recommendations

- Legislature establish a new regulatory authority with oversight authority on seismic resiliency of Critical Energy Infrastructures
 - Oregon Homeland Security Council (Oregon Revised Statute ORS 401.109)
 - Oregon Public Utility Commission
- Mandate all energy service providers complete Seismic Vulnerability Assessments (VA) and long-term Mitigation Plans by February 28, 2015, and report back to the Overseeing Authority.
- Mandate all energy service providers implement the top 10% findings from the VA by February 28, 2025, and provide annual performance reports to Overseeing Authority.
 - The remaining 90% be incorporated in the normal operations & maintenance, and capital projects plan, with the goal of achieving resiliency by February 28, 2065.
- Mandate all energy service providers provide annual performance reports to Overseeing Authority.

Electric Specific Recommendation

- Perform an Oregon regional electrical systems study within 1 year (feb 28, 2014)
 - It can be done independent of IOUs and COUs
 - Independent of infrastructure ownership
 - Provide broad reliability picture of the electrical systems
 - It can be shared in 1 year

(This has been done for the New Madrid earthquake area by US DOE's Argonne National Lab.)

Resilience Triangle (modified from MCEER)

Multidisciplinary Center for Earthquake Engineering Research

RESILIENT OREGON Workshop
October 5, 2012

TRANSPORTATION Assessment

Resilient OREGON Workshop
October 5, 2012

Highway Transportation

- Majority of Highway bridges built well before Seismic Specifications were available
- Landslides and Rockfalls make our highways even more vulnerable
- ODOT has performed a initial assessment of state owned bridges and landslide inventory West of Cascades
- A Draft of Highway Lifelines has been proposed, along with a mitigation plan

Resilient OREGON Workshop
October 5, 2012

Transportation Workgroup

- Highway Transportation
- Rail Transportation
- Air Transportation
- Water Transportation (River and Ocean Ports)
- Public Transit Services
- Local Agency Representatives
- Consultants
- Academia

Resilient OREGON Workshop
October 5, 2012

Highway Transportation



- The Highway Lifeline Maps and Seismic Options Report presented to OTC (06/21/2012)
- Highway assessment shows 3+ years needed to restore 90% capacity on Western OR
- 1-3 years restoring 60% capacity of Tier 1 Routes
- Accessing the damaged structures becomes an issue

Resilient OREGON Workshop
October 5, 2012

Transportation Workgroup

- Monthly meetings (in person, phone, or i-Link)
- Multimode Transportation Workshop (Sep. 17)
- Draft Report sent out on October 1st
 - *Resiliency Target: Minimal, Functional, and Operational
- Appendix "A"
 - * Highways, Rail, Airports, Ports, Public Transit
- Appendix "B"
 - * Local Transportation System

Resilient OREGON Workshop
October 5, 2012



Agency/Route	Minimal	Functional	Operational	Notes
W. Oregon (Outside Transport Zones)	Red	Yellow	Green	
Coos County (State - Tier 1 RSR)	Red	Yellow	Green	RS X</td
Del Norte	Red	Yellow	Green	RS X
Curry	Red	Yellow	Green	RS X
Coquille	Red	Yellow	Green	RS X
Clatsop	Red	Yellow	Green	RS X
Clatsop County (State - Tier 2 RSR)	Red	Yellow	Green	RS X
Washington	Red	Yellow	Green	RS X
W. Oregon (Outside Transport Zones - Tier 2 RSR)	Red	Yellow	Green	RS X
Washington	Red	Yellow	Green	RS X
W. Oregon (Outside Transport Zones - Other Routes)	Red	Yellow	Green	RS X
Washington	Red	Yellow	Green	RS X
Del Norte	Red	Yellow	Green	RS X
Curry	Red	Yellow	Green	RS X
Coquille	Red	Yellow	Green	RS X
Clatsop	Red	Yellow	Green	RS X
Clatsop County (State - Other Routes)	Red	Yellow	Green	RS X
Washington	Red	Yellow	Green	RS X
W. Oregon (Outside Transport Zones - Airport Routes)	Red	Yellow	Green	RS X
Washington	Red	Yellow	Green	RS X
Del Norte	Red	Yellow	Green	RS X
Curry	Red	Yellow	Green	RS X
Coquille	Red	Yellow	Green	RS X
Clatsop	Red	Yellow	Green	RS X
Clatsop County (State - Airport Routes)	Red	Yellow	Green	RS X
Washington	Red	Yellow	Green	RS X
W. Oregon (Outside Transport Zones - Airport Routes)	Red	Yellow	Green	RS X
Washington	Red	Yellow	Green	RS X
Del Norte	Red	Yellow	Green	RS X
Curry	Red	Yellow	Green	RS X
Coquille	Red	Yellow	Green	RS X
Clatsop	Red	Yellow	Green	RS X

Resilient OREGON Workshop
October 5, 2012



Rail Transportation

- Rail lines are generally privately owned
- Older bridges
- Landslides
- Liquefaction
- Tunnels
- No redundancy (long detours)



Resilient OREGON Workshop
October 5, 2012



Public Transit

- 5 – public transit regions in Oregon
- Public transit buses & school district buses can assist on emergency evacuation
- Coastal Transit facilities may have their own problems
- Factors controlling the resiliency
 - * Road Conditions
 - * The ability of drivers to respond
 - * Availability of fuel supplies

Resilient OREGON Workshop
October 5, 2012



Air Transportation

- 97 public-use airports in Oregon
- Redmond – **FEMA Primary**
- 57 – partially supported by FAA
- 28 – state owned (ODA)
- 16 – other municipalities
- >400 – private owned
- Runways – an issue

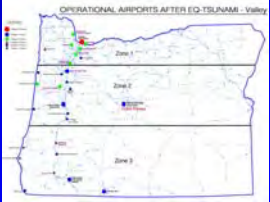

Resilient OREGON Workshop
October 5, 2012



Local Roads and Streets

- On the same condition as State Highways
- Cities & Counties identified alternative Routes
 - * Can be retrofitted for less \$\$
 - * Can be restored much quicker for Emergency Resp.
- A few cities (Portland, Albany) have identified local lifelines connecting to hospitals and emergency centers

Resilient OREGON Workshop
October 5, 2012



Water Transportation

- **River Ports**
- Docks – at risk
- Liquefaction
- Navigation Channel
- Major river crossings
- Dams & Locks



Resilient OREGON Workshop
October 5, 2012



Interdependency Assessment

- Supplement a highway “backbone” system with other modes to provide a statewide connectivity at the perceived lowest retrofit cost
- The highway backbone system:
 - * I-5, from I-84 (Portland) to OR58
 - * I-84, from I-5 (Portland) to US97
 - * US97, from I-84 to the CA Border, and
 - * OR58, from I-5 to US97

Resilient OREGON Workshop
October 5, 2012



Interdependency Assessment

- High priority Airports:
 - * Redmond – FEMA
 - * Portland International
 - * Salem
 - * Eugene
 - * Roseburg
 - * Medford
 - * Klamath Falls

These airports should be made resilient within 10 years

Resilient OREGON Workshop
October 5, 2012



Interdependency Assessment

- Ports considered part of Multimode Transportation System:
 - * Port of Portland
 - * The Dalles
 - * Hood River
 - * Cascade Locks
 - * Boardman

The overall plan needs to include a resiliency evaluation of the Columbia River channel

Resilient OREGON Workshop
October 5, 2012



Recommendations

- Perform selective vulnerability assessments in priority order for each transportation mode
- Identify local lifeline routes and detour routes for higher redundancy
- Develop mitigation strategies for other transportation modes, similar to highway's
- Further refine the Interdependency Strategy to ensure a statewide connectivity

**OREGON RESILIENCY
PLANNING**

Critical/Essential Buildings

Ed Quesenberry (Co-chair)	Ed Dennis Edward Wolf	Michael Wieber Richard Rogers
Trent Nagele (Co-chair)	Jason Thompson	Robert Johnson
Amit Kumar	Jennifer Eggers	Shane Downing
Andre Barbosa	Jim Weston	Shelly Duquette
Anne Monnier	Joe Gehlen	Terry Shugrue
David Bugni	Josh Richards	Tim Rippey
Dominic Matteri	Kevin Kaplan	Tonya Halog
	Kimberly Dills	Willy Paul
	Mark Tobin	

TABLE 1
ASSESSMENT APPROACH

2007 SSNA Data Set

- **Engineering Review, and conversion to Recovery Score**
 - Emergency Operations
 - Police and Fire Stations
 - Healthcare Facilities
 - K-12 Schools
 - Emergency Sheltering*

**CRITICAL/ESSENTIAL
BUILDINGS**

- Hospitals (60 facilities)
- Police/Fire Stations (109 police, 595 fire)
- Emergency Operations Centers (82)
- K-12 Schools (2,377 facilities)
- Emergency Sheltering Facilities
- Community Retail Centers and Banks
- Single Family Residential (960,000 est.)
- URM and Non Ductile Conc. Bldgs (40,000+ est.)
- Critical Government Facilities

TABLE 2
ASSESSMENT APPROACH

FEMA HAZUS Model

- **Statistical analysis based on census data**
- **Estimates quantity, size, type and age of structures**
- **Statistically determines expected damage for estimated building set**

TABLE 1
ASSESSMENT APPROACH

2007 DOGAMI Statewide Structural Needs Assessment (SSNA)

- Rapid Visual Screening (FEMA 154)
- Each building evaluated individually
- Screening factors include type of structure, age, occupancy, soil type, vertical irregularity, plan irregularity

TABLE 2
ASSESSMENT APPROACH

FEMA HAZUS Model

- **Converted damage estimates to Recovery Score**
 - Residential Housing
 - Community Retail Centers and Banks
 - Vulnerable Buildings*
 - Critical Government Facilities

FINDINGS

**Table 1 – 2007 SSNA
EOC, Police & Fire Stations**

Table 1. Target States of Recovery For Oregon's Buildings Based on DOGAMI Assessments and Engineering Review									
Infrastructure Cluster Facilities	Event Occurs	Phase 1 (hours)			Phase 2 (Days)		Phase 3 (Months)		
		4	24	72	30	60	4	18	36+
Emergency Operations Centers (Coastal)								X	
Emergency Operations Centers (Valley)							X		
Emergency Operations Centers (Eastern)					X				
Police Stations (Coastal)									X
Police Stations (Valley)							X		
Police Stations (Eastern)					X				
Fire Stations (Coastal)									X
Fire Stations (Valley)						X			
Fire Stations (Eastern)			X						

Target State
 X Current State (approx.)

FINDINGS

**Table 2 – FEMA Hazus
Retail Centers, Banking Institutions**

Table 2. Target States of Recovery For Oregon's Buildings Based on FEMA HAZUS Loss Estimations									
Infrastructure Cluster Facilities	Event Occurs	Phase 1 (hours)			Phase 2 (Days)		Phase 3 (Months)		
		4	24	72	30	60	4	18	36+
Community Retail Centers (Coastal)									X
Community Retail Centers (Valley)							X		
Community Retail Centers (Eastern)	X								
Financial/Banking (Coastal)							X		
Financial/Banking (Valley)							X		
Financial/Banking (Eastern)	X								

Target State
 X Current State (approx.)

FINDINGS

**Table 1 – 2007 SSNA
Healthcare Facilities**

Table 1. Target States of Recovery For Oregon's Buildings Based on DOGAMI Assessments and Engineering Review									
Infrastructure Cluster Facilities	Event Occurs	Phase 1 (hours)			Phase 2 (Days)		Phase 3 (Months)		
		4	24	72	30	60	4	18	36+
Healthcare Facilities (Statewide)								X	
Healthcare Facilities (Coastal)								X	
Healthcare Facilities (Valley)								X	
Healthcare Facilities (Eastern)					X				
Healthcare Facilities* (Statewide)									X
Healthcare Facilities* (Coastal)									X
Healthcare Facilities* (Valley)									X
Healthcare Facilities* (Eastern)					X				

Target State
 X Current State (approx.)

* Includes consideration of non-structural components

FINDINGS

**Table 2 – FEMA Hazus
Residential Housing and Vulnerable Bldgs**

Table 2. Target States of Recovery For Oregon's Buildings Based on FEMA HAZUS Loss Estimations									
Infrastructure Cluster Facilities	Event Occurs	Phase 1 (hours)			Phase 2 (Days)		Phase 3 (Months)		
		4	24	72	30	60	4	18	36+
Residential Housing (Coastal)						X			
Residential Housing (Valley)		X							
Residential Housing (Eastern)	X								
Vulnerable Buildings									X
Vulnerable Buildings							X		
Vulnerable Buildings									X

Target State
 X Current State (approx.)

FINDINGS

**Table 1 – 2007 SSNA
Schools and Emergency Sheltering**

Table 1. Target States of Recovery For Oregon's Buildings Based on DOGAMI Assessments and Engineering Review									
Infrastructure Cluster Facilities	Event Occurs	Phase 1 (hours)			Phase 2 (Days)		Phase 3 (Months)		
		4	24	72	30	60	4	18	36+
Primary/ K-8 (Coastal)								X	
Primary/ K-8 Centers (Valley)								X	
Primary/ K-8 (Eastern)					X				
Secondary/High School (Coastal)								X	
Secondary/High School (Valley)								X	
Secondary/High School (Eastern)					X				
Emergency Sheltering (Coastal)								X	
Emergency Sheltering (Valley)								X	
Emergency Sheltering (Eastern)					X				

Target State
 X Current State (approx.)

FINDINGS

**Table 2 – FEMA Hazus
Critical Government Facilities**

Table 2. Target States of Recovery For Oregon's Buildings Based on FEMA HAZUS Loss Estimations									
Infrastructure Cluster Facilities	Event Occurs	Phase 1 (hours)			Phase 2 (Days)		Phase 3 (Months)		
		4	24	72	30	60	4	18	36+
Critical Government Facilities (Coastal)									X
Critical Government Facilities (Valley)							X		
Critical Government Facilities (Eastern)	X						X		

Target State
 X Current State (approx.)

RECOMMENDATIONS

4.4.1 Existing Buildings

- **Exempt Buildings (4.4.1.1)**
 - One and two-family dwellings
 - Buildings in low seismic hazard area
 - Exempt buildings
- **Building Inventory (4.4.1.2)**

RECOMMENDATIONS

4.4.1 Existing Buildings

- **Upgrade Nonstructural Elements of Essential and Hazardous Facilities (4.4.1.5)**
- **Passive Trigger Seismic Strengthening Program (4.4.1.6)**
- **Require Disclosure of URM and Non-ductile Concrete Building's Seismic Resistance (4.4.1.8)**
- **Limitation of Liability (4.4.1.9)**

RECOMMENDATIONS

4.4.1 Existing Buildings

- **Mandatory Seismic Strengthening (4.4.1.3)**
 - URM and Non-ductile Concrete Buildings
 - Essential Facilities within 20 years
 - All others within 30 years
 - Hospitals within 15 years
 - EOC, Police, Fire within 30 years (non URM)
 - Buildings damaged by Earthquakes

RECOMMENDATIONS

4.4.2 New Buildings

- **Siting (4.4.2.1)**
- **Incentives for Performance Based Design (4.4.2.2)**
- **Permit Review of Significant Structures by Licensed Structural Engineers (4.4.2.3)**
- **Expand certain Special Inspections and Structural Observations (4.4.2.4)**

RECOMMENDATIONS

4.4.1 Existing Buildings

- **K-12 Schools (4.4.1.4)**
 - Expand seismic rehab grant program
 - Prioritize replacement of URM's
 - Require ASCE-31 seismic assessments
 - Database of school seismic assessments
 - Statewide plan to resume education

RECOMMENDATIONS

4.4.3 State Office of the Structural Engineer

- **Establish a lead agency for implementing and coordinating statewide seismic/structural resilience policy.**
- **Advocacy and education**
- **Assist other state agencies**
- **Research**
- **Develop administrative rules and standards**

RECOMMENDATIONS

- **4.4.3 Earthquake Performance Rating System**
 - Voluntary
 - Applicable to all building types, new and old
- **4.4.5 Education**
 - Public awareness
 - Education in schools
 - Contractor education

RECOMMENDATIONS

- **4.4.6 Timeline**
 - Now is the time to get started!
- **4.4.7 Emergency Response**
 - Database of post-earthquake inspectors
 - Establish protocols for volunteers
 - Strengthen Good Samaritan laws

THANK YOU!

CRITICAL BUILDINGS TASK GROUP

Ed Quesenberry (Co-chair)	Ed Dennis	Michael Wieber
Trent Nagele (Co-chair)	Edward Wolf	Richard Rogers
Amit Kumar	Jason Thompson	Robert Johnson
Andre Barbosa	Jennifer Eggers	Shane Downing
Anne Monnier	Jim Weston	Shelly Duquette
David Bugni	Joe Gehlen	Terry Shugrue
Dominic Matteri	Josh Richards	Tim Rippey
	Kevin Kaplan	Tonya Halog
	Kimberly Dills	Willy Paul
	Mark Tobin	

INFORMATION AND COMMUNICATIONS TECHNOLOGY

Oregon Resilience Plan Workshop
October 5, 2012

- ## Information and Communications Technology
- In the early phases of recovery achieving these capabilities may require the use of temporary/interim contingencies (i.e., mobile cellular towers) while more permanent repairs and installations are being done.
 - Establishing target timeframes for the tsunami inundation zone, beyond a minimal level of capability to support response, is not practical. A large amount of planning and prioritizing will need to be undertaken to identify which areas will be rebuilt first. These will then be the areas in which the information and communications systems will be re-established first.

Information and Communications Technology

KEY TO THE TABLE

Target Timeframe for recovery:

- Operational:** Restoration is up to 90% of capacity. A full level of service has been restored and is sufficient to allow people to use for non-essential needs like entertainment. 80%-90%
- Functional:** Although service is not yet restored to full pre-event capacity, it is sufficient to get the economy moving again (e.g. business uses for credit cards and banking). Limits may be placed on uses that take up a lot of capacity like streaming video. 50% - 60%
- Minimal:** A minimum level of service is restored, primarily for the use of emergency responders, repair crews, and in support of critical health and human services (mass care) 20% - 30%

Estimated time, under current conditions, for system wide recovery to be at or 90% of pre-event capacity

G
Y
R
X

Information and Communications Technology

TARGET STATES OF RECOVERY: INFORMATION AND COMMUNICATIONS TECHNOLOGY SECTOR

	Event occurs	0-24 hours	1-3 days	3-7 days	1 week-2 weeks	1 month-3 month	3 month-6 month	6 month-1 year	1 year-3 years	3+ years
ZONE 1 - COAST/Tsunami ZONE				R						
Buildings (includes Central Offices, Internet Exchange Points, and Cable Landings)									X	
Equipment in Buildings and on towers									X	
Towers									X	
Underground Lines									X	
Overhead Lines									X	

- ## Information and Communications Technology
- Planning Notes:
- Performance Capability for the purpose of recovery is viewed across all information and telecommunications systems supporting voice and data communications.
 - The restoration objectives are based on an assumption that all other lifelines, such as roads and electricity, are functioning at a level that will support restoration of the information and communications infrastructure.
 - In areas where the "customer" is not ready to accept service, then the service provider is not expected to meet established restoration timeframes.

Information and Communications Technology

TARGET STATES OF RECOVERY: INFORMATION AND COMMUNICATIONS TECHNOLOGY SECTOR

	Event occurs	0-24 hours	1-3 days	3-7 days	1 week-2 weeks	1 month-3 month	3 month-6 month	6 month-1 year	1 year-3 years	3+ years
ZONE 2 - COAST/ NON-Tsunami ZONE			R	Y	G					
Buildings									X	
Equipment in Buildings									X	
Towers									X	
Underground Lines								X		
Overhead Lines								X		

Information and Communications Technology

TARGET STATES OF RECOVERY: INFORMATION AND COMMUNICATIONS TECHNOLOGY SECTOR										
	Event occurs	0-24 hours	1-3 days	3-7 days	1 week-2 weeks	1 month-3 month	3 month-6 month	6 month-1 year	1 year-3 years	3+ years
ZONE 3 - VALLEY		R	Y	G						
Buildings						X				
Equipment in Buildings						X				
Towers						X				
Underground Lines						X				
Overhead Lines					X					

- ### Recommendations
- Include in site development and zoning codes the requirement for Information and Communications technology structures to be built to withstand the potential impacts of a scenario earthquake and tsunami.
 - This should include limitations on building in tsunami inundation areas, construction of antenna towers on buildings that do not meet the critical facility standard and accounting for potential of liquefaction and slope instability when construction towers, buildings, underground utilities and overhead lines.

Information and Communications Technology

TARGET STATES OF RECOVERY: INFORMATION AND COMMUNICATIONS TECHNOLOGY SECTOR										
	Event occurs	0-24 hours	1-3 days	3-7 days	1 week-2 weeks	1 month-3 month	3 month-6 month	6 month-1 year	1 year-3 years	3+ years
ZONE 4 - EASTERN OREGON		R	Y	G						
Buildings						X				
Equipment in Buildings						X				
Towers				X						
Underground Lines				X						
Overhead Lines				X						

- ### Recommendations
- Adopt clear statewide uniform standards, like the NEBS (Network Equipment-Building System), for the adequate performance and bracing of information and telecommunications equipment need to withstand the scenario event and establish a mechanism for reliable enforcement.
 - In conjunction with the ODOT's hardening of primary transportation routes, establish a hardened backbone for information and telecommunications systems

- ### Recommendations
- Recommended changes in practice that would make the sector compliant in 50 years.
- Establish oversight authority to a State entity that would be responsible for overseeing the resilience of the information and telecommunications industry operating and/or providing services in Oregon.
 - Require Central Offices, Internet Exchanges, remote terminals and submarine cable landings to be built to or retrofitted to the "critical facility" standard.

- ### Suggested Policy Changes
- Three Four suggested policy changes to enable those changes in practice?
1. Legislature establish a new regulatory authority to the Oregon Homeland Security Council (Oregon Revised Statute ORS 401.109) on seismic information and communication resiliency and security issues in cooperation with other relevant authorities.

Suggested Policy Changes

2. Mandate that information and communication service providers complete Seismic Vulnerability Assessments and long-term Mitigation Plans by February 28, 2014, and report to Oregon Homeland Security Council (Oregon Revised Statute ORS 401.109) and other relevant authorities.

Suggested Policy Changes

3. Mandate the information and communication service providers harden all Priority Paths (to achieve a resilient backbone) by February 28, 2018, and provide annual performance reports to Oregon Homeland Security Council (ORS 401.109) and other relevant authorities.
4. Mandate the information and communication service providers harden systems to the performance target restoration objectives by February 28, 2023, and provide annual performance reports to Oregon Homeland Security Council (ORS 401.109) and other relevant authorities.

QUESTIONS



Water/ Wastewater Committee

Resilience Workshop

5 October, 2012

Water & Wastewater Sector Table – Valley Zone

KEY TO THE TABLE

TARGET TIMEFRAME FOR RECOVERY:
 Desired time to restore component to 80-90% operational G
 Desired time to restore component to 50-60% operational Y
 Desired time to restore component to 20-30% operational R

TARGET STATES OF RECOVERY: WATER & WASTE WATER SECTOR

	0-24 hours	1-3 days	3-7 days	1 week - 2 weeks	2 weeks - 1 month	1 month - 3 months	3 months - 6 months	6 months - 1 year	1 year - 3 years	3+ years
Domestic water supply										
Possible water available at supply source (WTP, wells, impoundment)		R	Y		G			X		
Main transmission facilities, pipes, pump stations, and reservoirs ("backbone") operational		G					X			
Water supply to critical facilities available		Y	G				X			
Water for fire suppression – at key supply points		G		R						
Water for fire suppression – at fire hydrants				R	Y	G			X	
Water available at community distribution center/stations			Y	G	X					
Distribution system operational			R	Y	G				X	
Wastewater systems										
Threats to public health & safety controlled			R	Y		G			X	
Raw sewage contained & routed			R	Y		G		X		

Water and Wastewater Systems Participating in the W&WW Work Group

System / Community	Sector
City of Portland	Water & Wastewater
Tualatin Valley Water District	Water
City of Bend	Water
City of Gresham	Water
City of Pendleton	Water
City of Salem	Water & Wastewater
Clean Water Services	Wastewater
Coos Bay – North Bend Water Board	Water

Water & Wastewater Sector Table – Central / Eastern Zone

KEY TO THE TABLE

TARGET TIMEFRAME FOR RECOVERY:
 Desired time to restore component to 80-90% operational G
 Desired time to restore component to 50-60% operational Y
 Desired time to restore component to 20-30% operational R

TARGET STATES OF RECOVERY: WATER & WASTE WATER SECTOR

	0-24 hours	1-3 days	3-7 days	1 week - 2 weeks	2 weeks - 1 month	1 month - 3 months	3 months - 6 months	6 months - 1 year	1 year - 3 years	3+ years
Domestic water supply										
Possible water available at supply source (WTP, wells, impoundment)		X								
Main transmission facilities, pipes, pump stations, and reservoirs ("backbone") operational		X								
Water supply to critical facilities available		X								
Water for fire suppression – at key supply points		X								
Water for fire suppression – at fire hydrants		X								
Water available at community distribution center/stations		X								
Distribution system operational		X								
Wastewater systems										
Threats to public health & safety controlled		X								
Raw sewage contained & routed		X								

Water & Wastewater Sector Table – Coast (Non Tsunami) Zone

KEY TO THE TABLE

TARGET TIMEFRAME FOR RECOVERY:
 Desired time to restore component to 80-90% operational G
 Desired time to restore component to 50-60% operational Y
 Desired time to restore component to 20-30% operational R

TARGET STATES OF RECOVERY: WATER & WASTE WATER SECTOR

	0-24 hours	1-3 days	3-7 days	1 week - 2 weeks	2 weeks - 1 month	1 month - 3 months	3 months - 6 months	6 months - 1 year	1 year - 3 years	3+ years
Domestic water supply										
Possible water available at supply source (WTP, wells, impoundment)		R	Y		G			X		
Main transmission facilities, pipes, pump stations, and reservoirs ("backbone") operational		R	Y	G				X		
Water supply to critical facilities available		R	Y	X	G			X		
Water for fire suppression – at key supply points		R	Y		G			X		
Water for fire suppression – at fire hydrants				R	Y	G		X		
Water available at community distribution center/stations			R	Y	G	X				
Distribution system operational			R	Y	G			X		
Wastewater systems										
Threats to public health & safety controlled		R	Y		G			X		
Raw sewage contained & routed away from shoreline			R	Y		G		X		
Treatment plant operational to meet regulatory requirements				R	Y	G		X		
Major pump lines and pump stations operational				R	Y	G		X		
Distribution system operational				R	Y	G		X		

Estimate of Water Pipeline Breaks & Leaks for Participating Utilities

Characteristic	Estimate
Total Length of Pipe (miles)	4,592
Total Number of Breaks (number)	2,656
Total Number of Leaks (number)	941
Total Number of Services (number)	385,600
Service Line Breaks – Utility Side (2%)	7,712
Service Line Breaks – Customer Side (5%)	19,280

Why so vulnerable?

- Large, complex systems, above and below ground
- Highly dependent on other, vulnerable resources
 - Energy, transportation, chemicals
- Essential facilities in low lying areas along lakes, rivers, coastlines
 - Vulnerable to liquefaction
- Old facilities designed before reasonable seismic criteria in place
- Use of non-ductile materials vulnerable to ground motion
- Collection/distribution systems connections to above ground facilities

Major Recommendations

- General Recommendations
 - Public information campaign to “reset” expectations.
 - ORWARN is a vital resource. W/WW utilities should belong
 - Seismic response plans
 - Employee preparedness plans
 - Seismic design standards for pipelines
 - Business continuity plans
 - Seismic vulnerability criteria should be incorporated in all capital improvement planning

Closing the Gap – Water Systems

- Harden transmission facilities (bridges, river crossings, landslide areas)
- Install additional isolation valves
- Replace vulnerable pump stations built before 1970. Harden those built after
- Rebuild/redesign transitions between in-ground piping and above ground structures
- Replace 20-30% of transmission system piping (Coastal)
 - 80-90% (Valley)
- Replace 20-30% of distribution system piping (Coastal)(Valley)
- Replace tankage built before 1960.
- Harden tankage built after 1960.
- Incorporate seismic resiliency objectives in all future capital projects

Major Recommendations

- Water Specific
 - OHA to require seismic risk assessment as part of master plans
 - Encourage firefighters and water utilities to develop joint earthquake response plans
 - Identify and coordinate key water supply points
 - OHA to require seismic design considerations as part of routine design review
 - DEQ and OHA to establish goals and expectation for compliance following an event











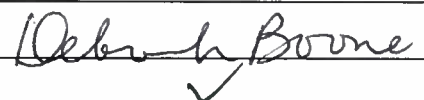

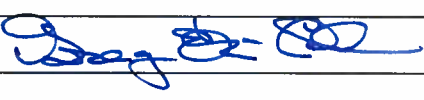

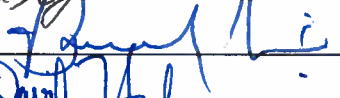
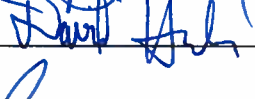
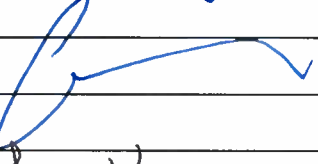
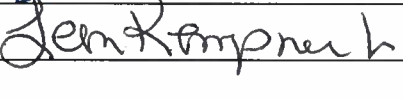
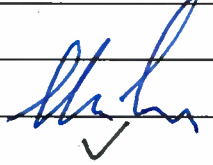

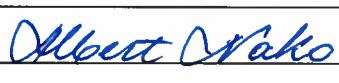
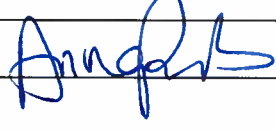
Closing the Gap – Wastewater Systems

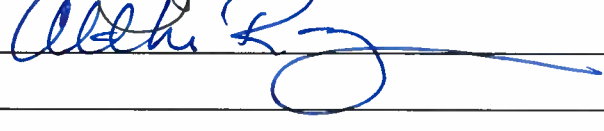
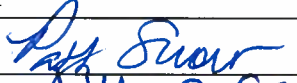
- Liquefiable soils, replace 50-60% of collection systems (Coastal and Valley)
 - 50-60% for trunk lines (Coastal)
 - 80-90% for trunk lines (Valley)
- Relocate or seismically upgrade treatment plants built before 2000
 - And all plants in liquefaction zones
- Rebuild or seismically harden pump stations built before 2000
- Provide for emergency power and chem supply
- Incorporate seismic resiliency into future capital improvement projects

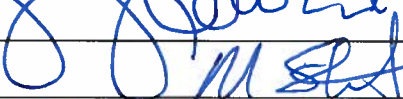
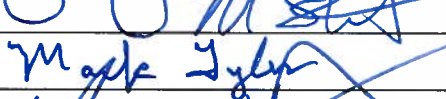
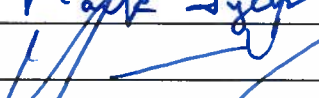
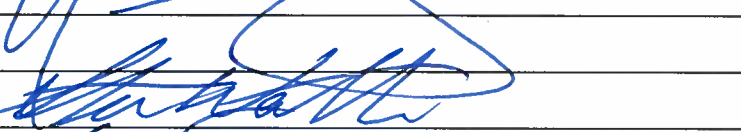
Major Recommendations

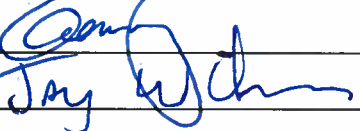
- Wastewater Specific
 - DEQ to require a seismic risk assessment as part of periodic update of facility plans
 - Wastewater agencies encourage to conduct more complete characterization of the impacts of estimated recovery times for seismic events
 - DEQ to coordinate with wastewater agencies on expectations for levels of service, compliance and standards following a major seismic event
 - Establish agreements for temporary sanitary services after an event
 - Encourage all agencies to plan for significant water quality impacts to Willamette and Columbia Rivers

October 5, 2012 Resilient Oregon Workshop
Sign-in Sheet

Scott Ashford	
Lee Beyer	
Deborah Boone	
Rick Carter	
Peter Courtney	
Ed Dennis	
Greg Ek-Collins	
Carl Farrington	
Fred Girod	
Chris Goldfinger	
JR Gonzalez	
David Harlan	
Onno Husing	
Francisco Ianni	
Bruce Johnson	
Leon Kempner	
Mark Knudson	
Andre LeDuc	
Stephen Lucker	
Ian Madin	
Robin Maxey	
Vicki McConnell	
Michael Mumaw	
Trent Nagele	
Albert Nako	
Jean O'Connor	
Anna Plumb	
Ed Quesenberry	
Jay Raskin	
Althea Rizzo	
Richard Rogers	
Cameron Smith	
Patty Snow	
Jeff Soulages	
Susan Steward	
Michael Stuhr	
Mark Tyler	
Yumei Wang	
Bryce Ward	
Stan Watters	
Gerry Williams	
Jay Wilson	
Ted Wolf	
Nate Wood	
Kent Yu	

Appendix IV List of Oregon Resilience Plan Contributors

Advisory Panel

Name

Cameron Smith
Peter Courtney/Dana Richardson
Lee Beyer
JR Gonzalez
Bruce Johnson
Ed Dennis
Yumei Wang
Onno Husing
Nate Wood
Scott Ashford
Chris Goldfinger
Andre LeDuc
Jeff Soulages
Edward Wolf
Leon Kempner
Vicki McConnell
Jean O'Connor
Dave Harlan

Affiliation

Governor's Office
State Legislature
State Legislature
Formerly Oregon Public Utility Commission
Oregon Department of Transportation
Formerly Oregon Dept. of Education
DOGAMI/NEHRP
Formerly Oregon Coastal Zone Mgmt Association
U.S. Geological Survey
Oregon State University
Oregon State University
University of Oregon
Intel
Oregon Citizen
Bonneville Power Administration
DOGAMI/WSSPC
Oregon Health Authority
Ports Manager

OSSPAC Steering Committee

Kent Yu (Chair, Public member/Structural)
Jay Wilson (Vice Chair, Public member/local government)
Althea Rizzo (OEM, State Earthquake/Tsunami Manager)
Ian Madin (DOGAMI)
Stan Watters (Public member/Utilities)

Earthquake and Tsunami Scenario Task Group

Name	Role	Affiliation	Category
Ian Madin	Chair	DOGAMI/OSSPAC	State Agency
Bill Burns		DOGAMI	State Agency
Art Frankel		US Geological Survey	Federal
Chris Goldfinger		Oregon State University	University
Matthew Mabey		Oregon Dept. of Transportation	State Agency
George Priest		DOGAMI	State Agency
Yumei Wang		DOGAMI	State Agency
Ivan Wong		URS/EERI	Engineer

Business & Work force Continuity Task Group

Name	Role	Affiliation	Category
Susan Steward	Co-Chair	BOMA/OSSPAC	Assoc. for Building Owners
Gerry Williams	Co-Chair	Construction Research/OSSPAC	Private consulting
Lori Chamberlain		Oregon Business Association	Business Association
Patrick Estenes		The Standard	Insurance
Kelley Okolita		Regence	Healthcare
Patrick Slabe		New Seasons Market	Food Retail
Bert Sorio		Regence	Healthcare
Jeffrey Soulages		Intel	High tech
Rick Van Dyke		Cambia	Healthcare
Bryce Ward		EcoNorthwest/OSSPAC	Economist

Coastal Communities Task Group

Name	Role	Affiliation	Category
Jay Wilson	Co-Chair	Clackmas County/OSSPAC	Local Government
Jay Raskin	Co-Chair	Ecola Creek/OSSPAC	Tsunami Advocate
Jacque Betz		Florence City Manager - Central Coast	Local Government
D-Rep Deborah Boone		Legislature - North Coast	State Legislature
Josh Bruce		Oregon Partnership for Disaster Resilience - State Level	University
Charlie Davis		Bandon City Planner and Emergency Manager - South Coast	Local Government
Sue Graves		Lincoln County School District - Central Coast	Local School District
Dave Harlan		Ports Manager State of Oregon	State Agency
Jeffrey Hepler		US Army Corps - Debris Management Program Manager	Federal
Maggie Kirby		Craft3 Development Manager	Non-profit Financial
R-Sen Jeff Kruse		Legislature - South Coast	State Legislature
Margo Lalich		Clatsop County Public Health Director	Local Government
Jack Lenox		Coquille Tribe Community Planner/Em Mgr - South Coast	Tribal Government
Gary Milliman		Brookings City Manager - South Coast	Local Government
Sam Steidel		City Councilor, Cannon Beach	Local Government
Wayne Stinson		Douglas County Emergency Manager - Central Coast	Local Government
Laren Woolley		Oregon Department of Land Conservation and Development	State Agency

Critical Buildings Task Group

Name	Role	Affiliation	Category
Ed Quesenberry	Co-Chair	Equilibrium Engineers LLC	Engineer
Trent Nagele	Co-Chair	VLMK	Engineer
Andre Barbosa	Resource Manager	Oregon State University	University
David Bugni	Secretary	David Bugni & Associates	Engineer
Ed Dennis		Dept. of Education	State Agency
Kimberly Dills		OHA/Center for Disease Control and Prevention	State Agency
Shane Downing		ORARNG	State Agency
Shelly Duquette	Public Relations	City of Portland	Local Government
Jennifer Eggers	Meeting Coordinator	Degenkolb Engineers	Engineer
Joe Gehlen	Resource Manager	Kramer Gehlen	Engineer
Tonya Halog		J.G. Pierson	Engineer

Name	Role	Affiliation	Category
Robert Johnson		Johnson & Broderick Engineering	Engineer
Kevin Kaplan		VLMK	Engineer
Amit Kumar	Treasurer	City of Portland BDS	Local Government
Dominic Matteri		Kramer Gehlen	Engineer
Anne Monnier	Data Manager	KPFF	Engineer
Willy Paul		Kaiser Permanente	Healthcare Provider
Josh Richards	Resource Manager	KPFF	Engineer
Tim Rippey		TM Rippey Consulting Engineers	Engineer
Richard Rogers		Oregon Building Codes	State Agency
Terry Shugrue	Data Manager	Turner Construction	Contractor
Jason Thompson		KPFF	Engineer
Mark Tobin		KPFF	Engineer
Jim Weston		Sacred Heart Medical Center/PeaceHealth	Healthcare Provider
Michael Wieber		NW Seismic Retrofit	Contractor
Edward Wolf	Public Relations	Freelance Writer and Analyst	Oregon Citizen

Transportation Task Group

Name	Role	Affiliation	Category
Bruce Johnson	Chair	ODOT Bridges	State Agency
Martin Callery		Port of Coos Bay	Port
Lieutenant Meredith Condon		USCG	Federal Agency
Chris Corich		Oregon State Aviation Board	State Agency
Peter Duskica		Portland State University	University
Greg Ek-Collins		ODOT Maintenance HQs	State Agency
Herb Florer		Port of Astoria	Port
Doug Grafe		Oregon Department of Forestry	State Agency
Elsie Hamner		Port of Coos Bay	Port
Chuck Hutto		ODOT Motor Carrier	State Agency
Doug Kirkpatrick		Consultant, HDR	Engineer
Jeff Langstrom		LOC, City of Eugene	Local Government
Lee Lazaro		ODOT Public Transit Division	State Agency
Mark Libby		Consultant, HDR, Secretary, ASCE Oregon Section	Engineer

Name	Role	Affiliation	Category
Matt Maass		Oregon Department of Aviation	State Agency
Nason J. McCullough		Ch2M-Hill, Ports and Harbors	Engineer
Bob Melbo, State Rail Planner		ODOT Rail Division	State Agency
Curran Mohney		ODOT Geology	State Agency
Lucy Moore		ODOT Maintenance HQs	State Agency
Nancy Murphy		ODOT Planning and Lifeline Contract Administrator	State Agency
Albert Nako		ODOT Bridge	State Agency
David Neys		ODOT Maintenance District Rep.	State Agency
David Olongiagh		City of Portland	Local Government
Jeff Olson		Consultant, Quincy	Engineer
Jon Oshel		Assoc. of Counties	Local Government Association
Tom Peterson		Port of Portland	Port
Craig Shike		ODOT Bridge	State Agency
Craig Totten		Consultant, KPFF	Engineer
Tom Wharton		Port of Portland	Port
John Wilson		Oregon Department of Aviation	State Agency
Holly Winston		ODOT Senior Local Bridge Standards Engineer	State Agency

Energy Task Group

Name	Role	Affiliation	Category
Stan Watters	Co-Chair	Port of Portland	Port
JR Gonzalez	Co-Chair	JRG Engineering	Engineer
Heide Caswell		PacifiCorp	Power Supplier
Rick Carter		Public Utilities Commission	State Agency
Brian Doherty		Miller Nash, llp	Lawyer
Michael Dougherty		Public Utilities Commission	State Agency
Del Draper		Williams	Pipeline
Dave Ford		PGE	Power Supplier
Debbie Guerra		PacifiCorp	Power Supplier
Teresa Hagins		Williams	Pipeline
Marion Haynes		Portland General Electric	Power Supplier
Leon Kempner, Jr.		Bonneville Power Admin.	Federal

Name	Role	Affiliation	Category
Brian Knight		WRK Engineeres	Engineer
Lori Koho		Public Utilities Commission	State Agency
Christy Munro		Bonneville Power Admin.	Federal
Bruce Paskett		NW Natural	Natural Gas Supplier
Robbie Roberts		NW Natural	Natural Gas Supplier
Dave Stuckey		Oregon Emerg. Mgmt.	State Agency
Jack Vranish		PacifiCorp	Power Supplier
Yumei Wang		DOGAMI	State Agency
Tashiana Wanger		PacifiCorp	Power Supplier
Grant M. Yoshihara		NW Natural	Natural Gas Supplier

Information and Communications Task Group

Name	Role	Affiliation	Category
Michael Mumaw	Chair	Beaverton/OSSPAC	Local Government
Rick Carter		Public Utilities Commission	State Agency
Michael Dougherty		Public Utilities Commission	State Agency
Walter Duddington		Integra Telecom	Communication Provider
JR Gonzalez		JRG Engineering	Engineer
Alexis Kwasinki		UT Austin	University
Devon Lumbard		Degenkolb	Engineer
Kelley Stember		Sprint	Communication Provider
Alex Tang		ASCE TCLEE	Subject Expert
Yumei Wang		DOGAMI	State Agency
Stan Watters		Port of Portland	Port
Geoffrey Williams		Integra Telecom	Communication Provider

Water & Waste Water Task Group

Name	Role	Affiliation	Category
Mike Stuhr	Co-Chair	Portland Water Bureau	Water Provider
Mark Knudson	Co-Chair	Tualatin Valley Water District	Water Provider
Don Ballantyne		Degenkolb Engineers	Engineer
Steve Behrandt		Portland BES	Water Provider
James Bela		Oregon Earthquake Awareness	Earthquake nonprofit
Andy Braun		Clean Water Services	Waste water
Scott Burns		Portland State University	University
Mel Damewood		Eugene Water & Elec. Board	Water Provider
Jim Doane		State Board: Examiners for Eng. & Land Surveying	State Agency
Michael Doane		Interested Individual	Oregon Citizen
Tom Hickmann		City of Bend	Water Provider
Gary Irwin		Portland BES - collection systems	Waste water
Gwynn Johnson, Ph.D.		Portland State University	University
Jeff Leighton		Portland Water Bureau	Water Provider
Arturo Leon, Ph.D.		Oregon State University	University
Ian Madin		DOGAMI	State Agency
Jim Male		University of Portland	University
Jim Newell		Degenkolb Engineers	Engineer
Bob Patterson		City of Pendleton	Water Provider
Sherry Patterson		Rivergrove Water Dist	Water Provider
Todd Perimon		AECOM	Engineer
Brad Phelps		CH2M-Hill	Engineer
Jeff Rubin		Tualatin Valley Fire and Rescue	Local Government
Rob Schab		Coos Bay - North Bend	Water Provider
Ken Schlegel		Clean Water Services	Waste water
Brian Stahl		City of Gresham	Water Provider
Jeffrey H. Winchester		Salem Public Works	Water Provider
Kent Yu		OSSPAC	State Agency