



Oregon

Theodore R. Kulongoski, Governor

Department of Transportation
Technical Services
Roadway Engineering Section
355 Capitol Street NE, Room 222
Salem, OR 97301-3871
Telephone 503-986-3714
FAX 503-986-3749

DATE: February 4, 2010

Addendum No. 1

TO: PLAN HOLDERS

PREPARED BY:

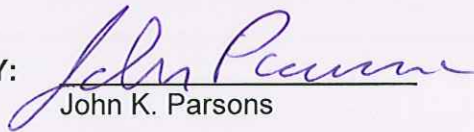
John K. Parsons

APPROVED BY:

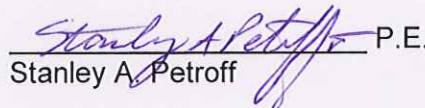
 P.E.
Stanley A. Petroff

SUBJECT: OR214: Front Street Ramp – Progress Way Section
Hillsboro- Silverton Highway
Marion County
Grading, Structure and Paving Project
(Bids to be opened and read February 11, 2010)

The following changes are made to the Project Bid Booklet:

1. The following changes are made to the Project Bid Items:

a. Unit change:

Number	Item	Unit		Quantity	
		Original	New	Original	New
0410	MONOLITHIC CURB AND SIDEWALKS	FOOT	SQFT	1,890.00	1,890.00

b. Name change:

Number	Item
0420	PEDESTRIAN RAIL

Make a copy of and use the new attached Bid Sheets. A Bid **not** including these new Bid Sheets **will be rejected as non-responsive**.

OR214: Front Street Ramp – Progress Way Section
Hillsboro- Silverton Highway
Marion County
Grading, Structure and Paving Project
(Bids to be opened and read February 11, 2010)

Addendum No. 1

The following changes are made to the Project Plans:

1. Plan sheets 1A, 2, and S-11613 are replaced with revised plan sheets 1A, 2, and S-11613.

These changes will be included in the Contract for this Project. It is understood that your Bid will be submitted accordingly.

Make copies of the new Bid Sheets to replace the Special Provisions Bid Schedule Sheets.

SAP:jkp

Attachments: New Bid Sheets
Revised Plan Sheets

BID SCHEDULE

CONTRACT ID: 14209

PROJECT: OR214: FRONT STREET RAMP -
PROGRESS WAY SIDEWALK

PROJECT KEY: 14708

ADDENDUM NUMBER: 1

ITEM NO	ITEM DESCRIPTION	QUANTITY AND UNITS	UNIT PRICE (IN FIGURES)	BID AMOUNT (IN FIGURES)
---------	------------------	--------------------	----------------------------	----------------------------

SECTION 0001 TEMPORARY FEATURES AND APPURTENANCES

0010	0210-0100000A MOBILIZATION	LS	ALL	
0020	0225-0100000A TEMPORARY PROTECTION AND DIRECTION OF TRAFFIC	LS	ALL	
0030	0225-0102000J TEMPORARY SIGNS	SQFT	135.00	
0040	0225-0105000E TEMPORARY BARRICADES, TYPE III	EACH	3.00	
0050	0225-0145000E TEMPORARY PLASTIC DRUMS	EACH	25.00	
0060	0225-0168000T FLAGGERS	HOUR	600.00	
0070	0280-0100000A EROSION CONTROL	LS	ALL	
0080	0280-0105000J MATTING	SQYD	1,620.00	
0090	0280-0106000E CHECK DAM	EACH	5.00	
0100	0280-0114000E INLET PROTECTION	EACH	4.00	
0110	0290-0100000A POLLUTION CONTROL PLAN	LS	ALL	

SECTION 0002 ROADWORK

BID SCHEDULE

CONTRACT ID: 14209

PROJECT: OR214: FRONT STREET RAMP -
PROGRESS WAY SIDEWALK

PROJECT KEY: 14708

ADDENDUM NUMBER: 1

ITEM NO	ITEM DESCRIPTION	QUANTITY AND UNITS	UNIT PRICE (IN FIGURES)	BID AMOUNT (IN FIGURES)
0120	0310-0102000J REMOVAL OF WALKS AND DRIVEWAYS	340.00 SQYD		
0130	0310-0104000E REMOVAL OF INLETS	1.00 EACH		
0140	0310-0106000A REMOVAL OF STRUCTURES AND OBSTRUCTIONS	ALL LS		
0150	0310-9Z90000F REMOVAL OF GUARDRAIL	825.00 FOOT		
0160	0320-0100000A CLEARING AND GRUBBING	ALL LS		
0170	0330-0101000K DITCH EXCAVATION	40.00 CUYD		
0180	0330-0105000K GENERAL EXCAVATION	1,320.00 CUYD		
0190	0350-0103000J RIPRAP GEOTEXTILE, TYPE 1	5.00 SQYD		
0200	0350-0105000J SUBGRADE GEOTEXTILE	790.00 SQYD		
0210	0390-0105000K LOOSE RIPRAP, CLASS 50	2.50 CUYD		

SECTION 0003 DRAINAGE AND SEWERS

0220	0445-035012AF 12 INCH STORM SEWER PIPE, 5 FT DEPTH	20.00 FOOT		
0230	0445-0700120E SLOPED END SECTIONS, 12 INCH	1.00 EACH		

BID SCHEDULE

CONTRACT ID: 14209

PROJECT: OR214: FRONT STREET RAMP -
PROGRESS WAY SIDEWALK

PROJECT KEY: 14708

ADDENDUM NUMBER: 1

ITEM NO	ITEM DESCRIPTION	QUANTITY AND UNITS	UNIT PRICE (IN FIGURES)	BID AMOUNT (IN FIGURES)
0240	0470-0101000E CONCRETE STORM SEWER MANHOLES	1.00 EACH		
0250	0470-0319000E CONCRETE INLETS, TYPE G-2MA	1.00 EACH		
0260	0490-0100000E ADJUSTING BOXES	1.00 EACH		
0270	0490-0104000E CONNECTION TO EXISTING STRUCTURES	1.00 EACH		
0280	0490-0105000E ADJUSTING INLETS	1.00 EACH		
0290	0490-0117000E FILLING ABANDONED STRUCTURES	1.00 EACH		
0300	0490-0120000E MINOR ADJUSTMENT OF MANHOLES	1.00 EACH		

SECTION 0004 BRIDGES

0310	0596-0105000J RETAINING WALL, CONTRACTOR'S OPTION	1,123.00 SQFT		
0320	0599-0100000J CONCRETE SLOPE PAVING	165.00 SQFT		

SECTION 0005 BASES

0330	0640-0100000M AGGREGATE BASE	361.00 TON		
------	---------------------------------	---------------	--	--

SECTION 0006 WEARING SURFACES

BID SCHEDULE

CONTRACT ID: 14209

PROJECT: OR214: FRONT STREET RAMP -
PROGRESS WAY SIDEWALK

PROJECT KEY: 14708

ADDENDUM NUMBER: 1

ITEM NO	ITEM DESCRIPTION	QUANTITY AND UNITS	UNIT PRICE (IN FIGURES)	BID AMOUNT (IN FIGURES)
0340	0744-0302000M LEVEL 3, 1/2 INCH DENSE MHMAC MIXTURE	237.00 TON		
0350	0749-0100000E EXTRA FOR ASPHALT APPROACHES	1.00 EACH		
0360	0759-0103000F CONCRETE CURBS, CURB AND GUTTER	920.00 FOOT		
0370	0759-0110000F CONCRETE CURBS, STANDARD CURB	247.00 FOOT		
0380	0759-0122000J CONCRETE ISLANDS	510.00 SQFT		
0390	0759-0126000J CONCRETE DRIVEWAYS	1,680.00 SQFT		
0400	0759-0128000J CONCRETE WALKS	9,270.00 SQFT		
0410	0759-0134000J MONOLITHIC CURB AND SIDEWALKS	1,890.00 SQFT		
0420	0759-0162000F PEDESTRIAN RAIL	260.00 FOOT		

SECTION 0007 PERMANENT TRAFFIC SAFETY AND GUIDANCE DEVICES

0430	0820-0100000F CONCRETE BARRIER	350.00 FOOT		
0440	0851-0101000F PAVEMENT LINE REMOVAL	1,219.00 FOOT		
0450	0865-0107000F THERMOPLASTIC, NON-PROFILE, 120 MILS, EXTRUDED	2,765.00 FOOT		

BID SCHEDULE

CONTRACT ID: 14209

PROJECT: OR214: FRONT STREET RAMP -
PROGRESS WAY SIDEWALK

PROJECT KEY: 14708

ADDENDUM NUMBER: 1

ITEM NO	ITEM DESCRIPTION	QUANTITY AND UNITS	UNIT PRICE (IN FIGURES)	BID AMOUNT (IN FIGURES)
0460	0867-0103000E PAVEMENT LEGEND, TYPE B: ARROWS	3.00 EACH		
0470	0867-0131000E PAVEMENT LEGEND, TYPE B-HS: BICYCLE LANE STENCIL	4.00 EACH		
0480	0867-0145000J PAVEMENT BAR, TYPE B	413.00 SQFT		

SECTION 0008 PERMANENT TRAFFIC CONTROL AND ILLUMINATION SYSTEMS

0490	0905-0100000A REMOVE EXISTING SIGNS	ALL LS		
0500	0910-0100000K WOOD SIGN POSTS	144.00 FBM		
0510	0940-0134000J TYPE "Y1" SIGNS IN PLACE	66.00 SQFT		
0520	0970-0100000A POLE FOUNDATIONS	ALL LS		
0530	0970-0101000A LIGHTING POLES, FIXED BASE	ALL LS		
0540	0970-0103000A LIGHTING POLE ARMS	ALL LS		
0550	0970-0104000A LUMINAIRES, LAMPS, AND BALLASTS	ALL LS		
0560	0970-0105000A SWITCHING, CONDUIT, AND WIRING	ALL LS		

BID SCHEDULE

CONTRACT ID: 14209

PROJECT: OR214: FRONT STREET RAMP -
PROGRESS WAY SIDEWALK

PROJECT KEY: 14708

ADDENDUM NUMBER: 1

ITEM NO	ITEM DESCRIPTION	QUANTITY AND UNITS	UNIT PRICE (IN FIGURES)	BID AMOUNT (IN FIGURES)
0570	0970-0106000A REFURBISHING AND REINSTALLING EXISTING ILLUMINATION SYSTEMS	LS ALL		
0580	0990-9Z90000A WIRELESS PEDESTRIAN CROSSING INSTALLATION	LS ALL		

SECTION 0009 RIGHT-OF-WAY DEVELOPMENT AND CONTROL

0590	1030-0108000R PERMANENT SEEDING	ACRE 0.42		
0600	1030-0118000R WATER QUALITY SEEDING	ACRE 1.00		
0610	1050-0135000F CL-6 CHAIN-LINK FENCE	FOOT 260.00		
0620	1070-0100000E SINGLE MAILBOX SUPPORTS	EACH 1.00		
0630	1092-0100000A WATER QUALITY SWALE	LS ALL		
	TOTAL BID			

INDEX OF SHEETS CONT'D.

SHEET NO.	DESCRIPTION
2, 2A, 2A-2	Typical Sections
2B, 2B-2, 2B-3	Details
2C	Traffic Control Plan Advance Signing
2D	Pipe Data Sheet
3	Alignment And General Construction
3A	Construction Notes
3A-2	Drainage & Utilities
3A-3	Profiles
4	Alignment And General Construction
4A	Construction Notes
4A-2	Drainage & Utilities
5	Alignment And General Construction
5A	Construction Notes
5A-2	Drainage & Utilities
6	Alignment And General Construction
6A	Construction Notes
6A-2	Drainage & Utilities
GEO/HYDRO	
GA Thru GA-4 Incl.	Erosion Control Plan
TRAFFIC	
ST	Pavement Marking Plan
S-11612	Pedestrian Crossing And Illumination Plan
S-11613	Sign Details
S-11614	Pedestrian Crossing Details
S-11615	Illumination Details
RETAINING WALL	
GHB-1	Pedestrian Path/Retaining Wall Plan And Elevation
GHB-2	General Notes, Typ. Section & Misc. Details

Std. Drg. Nos.

- RD100 - Mailbox Support
- RD101 - Mailbox Installation

- RD316 - Sloped Ends For Metal Pipe
- RD320 - Paved End Slope For Culverts 60" Maximum Pipe Size
- RD336 - Manholes
- RD360 - Manhole Frame Adjustment
- RD364 - Concrete Inlets
- RD380, RD390 - Pipe Fill Height Tables

- RD500 - Precast Concrete Barrier Pin And Loop Assembly
- RD516 - Securing Concrete Barrier To Roadway

- RD610 - Asphalt Pavement Details

- RD700 - Curbs
- RD705 - Islands
- RD710 - Accessible Route Islands
- RD720 - Sidewalks
- RD730, RD735 - Curb Line Sidewalk Driveways or Alleys
- RD755 - Sidewalk Ramp Details
- RD757 - Sidewalk Ramp Placement
- RD759 - Truncated Dome Details And Locations

- RD815 - Chain Link Fence

- RD1005 - Check Dams
- RD1010, RD1015 - Inlet Protection
- RD1055 - Matting

- BR246 - Pedestrian Rail

- TM200 - Sign Installation Details
- TM201 - Miscellaneous Sign Placement Details
- TM204 - Flag Board Mounting Details

- TM300, TM301 - Illumination Control Cabinets

- TM457 - Vehicle, Ped. Signal & Push Button Mounting Details
- TM458 - Pedestrian Ramp Placement Details
- TM467 - Ped. Signal And Ped. Push Button Details

- TM600, TM601 - Multi-Post Breakaway Sign Supports
- TM602 - Triangular Base Breakaway Multi-Direction Slip Base
- TM629, TM630 - Slip Base & Fixed Base Luminaire Supports
- TM635 - Breakaway Sign & Luminaire Supports
- TM670 - Perm. Signing Wood Post Supports Sizing Charts
- TM671 - 3 Second Gust Wind Speed Isotach
- TM676 - Sign Attachments
- TM677 - Sign Mounts
- TM681 - Square Tube Sign Supports

- TM800 - Tables, Abrupt Edge And PCMS Details
- TM820 - Temporary Barricades
- TM821 - Temporary Sign Supports
- TM840 - Closure Details
- TM850 - 2-Lane, 2 Way Roadways

-  BR246 - Pedestrian Rail

REVISIONS	
	Revised 02-04-2010 Added drg. no. BR246

OR 214: FRONT STREET RAMP - PROGRESS WAY SEC.		
HILLSBORO - SILVERTON HIGHWAY MARION COUNTY		
FEDERAL HIGHWAY ADMINISTRATION	PROJECT NUMBER	SHEET NO.
OREGON DIVISION	X-TEA-8375(004)	1A

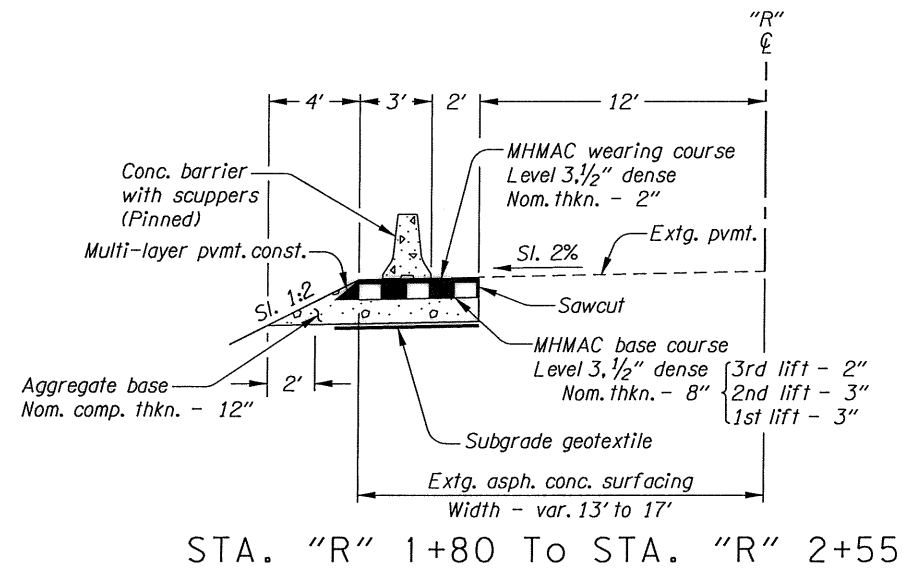
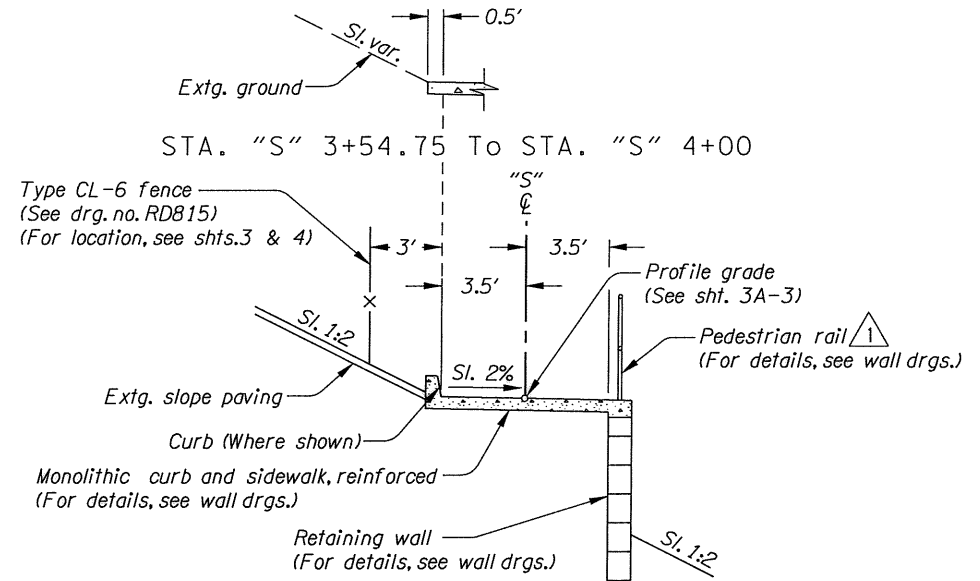
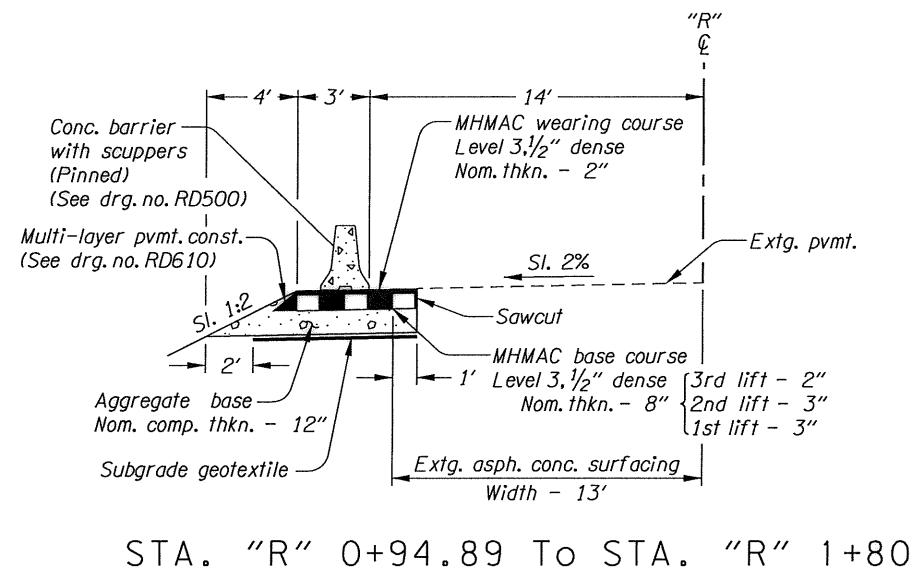
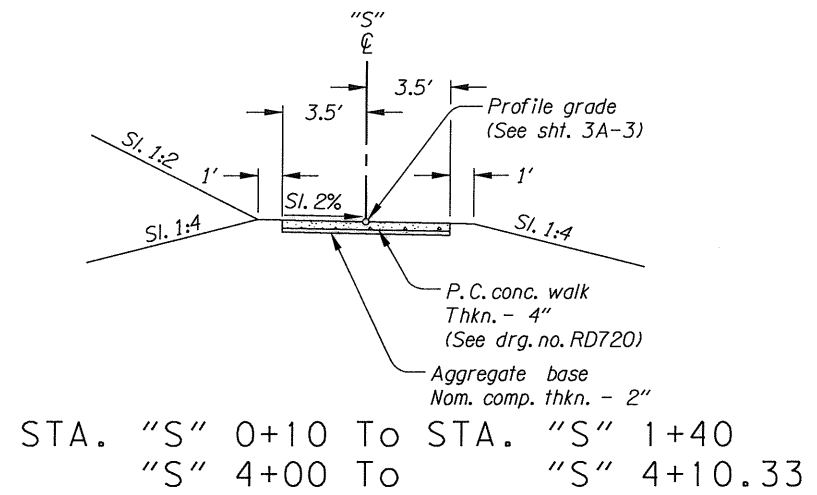
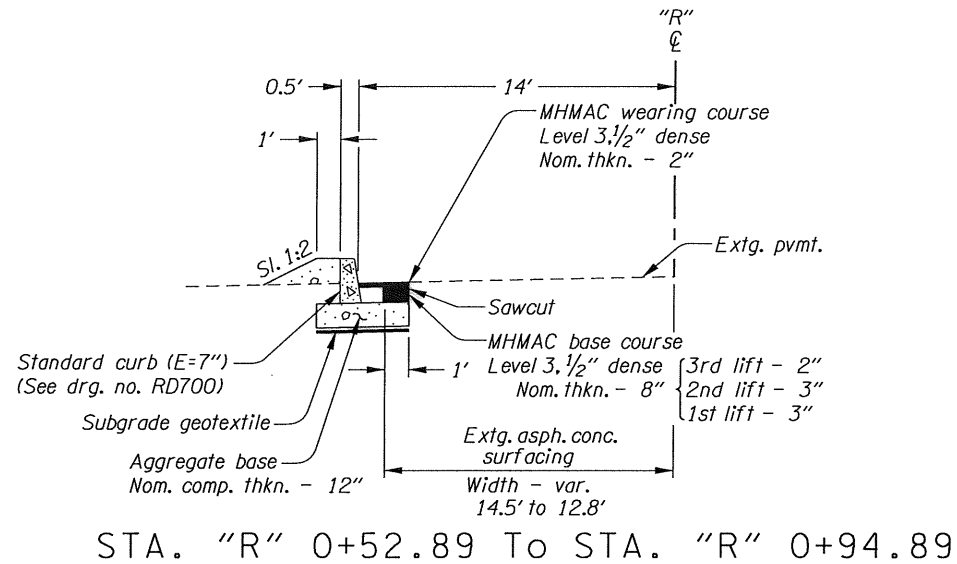

STA. "S" 1+40 To STA. "S" 4+00

REVISIONS	
⚠	Revised 02-04-2010
	Revised pedestrian rail

NOTE:
Side slopes are shown as vertical to horizontal.

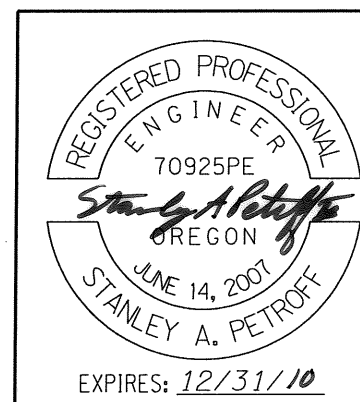

OREGON DEPARTMENT OF TRANSPORTATION

Corporate Office: 920 COUNTRY CLUB ROAD, SUITE 100B EUGENE, OREGON 97401-8089
 5005 SW MEADOWS ROAD, SUITE 120 LAKE OSWEGO, OREGON 97035-4288
 2235 MISSION STREET SE, SUITE 100 SALEM, OREGON 97302-1295
 831 OHARE PARKWAY MEDFORD, OREGON 97504-4005

OR 214: FRONT STREET RAMP - PROGRESS WAY SEC.
 HILLSBORO - SILVERTON HIGHWAY
 MARION COUNTY

Design Team Leader - Fred Willer
 Designed By - Stan Petroff
 Drafted By - Blake Phillips

TYPICAL SECTIONS

SHEET NO. **2**

