

MOTOR CARRIER SAFETY

PART 393 – Parts and Accessories Necessary for Safe Operation

Every CMV must be equipped with certain standard equipment. Other optional equipment or accessories are permitted only if these items do not decrease the operational safety of the vehicle.

Note: See also the periodic inspection items and standards prescribed in Appendix G to Subchapter B.

BRAKES

Brake Systems **393.40 / 393.41**

CMV's must be equipped with the following brake systems which must meet the braking requirements of FMCSR Part 393 and/or Federal Motor Vehicle Safety Standards (FMVSS) Part 571, as applicable:

- Service brakes
- Parking brakes
- Emergency brakes

Brakes on all Wheels **393.42 / 393.48**

Every CMV must be equipped with brakes acting on all wheels, with the following exceptions:

- Trucks and truck tractors with three or more axles, manufactured before July 25, 1980, are not required to have steering axle brakes. However, the vehicle must meet the braking requirements of 393.52.
- Vehicles being towed in a driveaway-towaway operation. However, the combination must meet the requirements of 393.52.
- Any trailer with a gross weight of 3,000 pounds or less, provided the trailer weight does not exceed 40 percent of the weight of the power unit.
- Three-axle dollies, steered by a co-driver (tillerman), are not required to have steering axle brakes.
- Loaded housemoving dollies, and specialized trailers and dollies transporting furnaces, reactors, and similar vehicles, provided the combination does not exceed 20 mph. However, the combination must be able to stop within 40 ft.

Breakaway and Emergency Braking **393.43**

Every power unit and its trailer must be equipped with the following emergency braking systems:

Power unit -

- **Tractor protection:** The power unit must have adequate service brakes to stop the power unit in the event of a trailer breakaway.
- **Trailer emergency brakes:** Each power unit with air brakes must

MOTOR CARRIER SAFETY

PART 393 – Parts and Accessories Necessary for Safe Operation

have both a manual and an automatic system for setting the emergency brakes on a trailer with air brakes. *

Trailer -

Breakaway: Every trailer must be equipped with brakes that apply automatically if the trailer breaks away from the power unit. *

* *Does not apply to driveaway-towaway operations.*

Brake Components

All brake components, including those identified below, must be installed, maintained, and protected to prevent leaks and to ensure proper functioning of the brake systems.

- Brake tubing and hoses – 393.45
- Brake chambers, slack adjusters, linings/pads, drums/rotors – 393.47
- Reservoirs – 393.50

Brake Warning Devices and Gauges 393.51

Buses, trucks, and truck tractors must be equipped with a signal that provides a warning to the driver when a failure occurs in the vehicle's service brake system. This signal requirement covers hydraulic brake systems, air brake systems, vacuum brake systems, and hydraulic brakes applied or assisted by air or vacuum.

Automatic Brake Adjusters and Adjustment Indicators 393.53

The following CMV's must be equipped with automatic brake adjusters:

- Hydraulic-braked vehicles manufactured on or after October 20, 1993.
- Air-braked vehicles manufactured on or after October 20, 1994. Must also have brake adjustment indicators.

Antilock Brake Systems (ABS) 393.55

The following CMV's must be equipped with antilock brake systems: *

- Truck-tractors manufactured on or after March 1, 1997.
- All other vehicles with air brakes manufactured on or after March 1, 1998.
- Hydraulic-braked trucks and buses manufactured on or after March 1, 1999.

Each antilock brake system must include ABS malfunction indicators.

* *Does not apply to driveaway-towaway operations.*

MOTOR CARRIER SAFETY

PART 393 – Parts and Accessories Necessary for Safe Operation

COUPLING DEVICES

General Requirements
393.70

Coupling devices, including fifth wheel assemblies, drawbars/tow-bars and drawbar eyes, pintle hooks, turntables, safety devices, and saddle-mounts*, must be properly secured and allow for proper alignment between the towing vehicle and the towed vehicle. Coupling devices must be free of excessive wear and cracks. No securement bolts or rivets are allowed to be loose or missing.

* See 393.71 for driveaway-towaway (saddle-mount) operations.

Fifth Wheel Assemblies
393.70(b)

- Every fifth wheel assembly must have a *locking device* to prevent separation or excessive play of the upper and lower halves of the fifth wheel. The locking device shall apply automatically on coupling.
- The upper and lower fifth wheel halves must be located to allow for equal *weight distribution* on the axles of the towed and towing vehicles.

Full Trailers
393.70(c)

- The tow-bar used to tow a full trailer must have a *locking device* to prevent separation of the towed and towing vehicles.
- The *tow-bar eye* and *pintle hook* must not have excessive play, nor be repaired by welding.

Safety Devices
393.70(d)

Every full trailer and converter dolly must have safety device(s) to prevent separation of the towed and towing vehicles in the event of a tow-bar failure. The safety devices must meet the following requirements:

- Must not be attached to the pintle hook or other attachment device.
- Must have an ultimate breaking strength equal to the weight of the towed vehicle.
- Must prevent the tow-bar from dropping to the ground in case the tow-bar fails or becomes disconnected. The safety device must not have excess slack.

Number of safety devices:

Hinged/swiveled tow-bar, full trailer or converter dolly: Must have one of the following:

- *Two separate chains/cables* running along both sides of the tow-bar.

MOTOR CARRIER SAFETY

PART 393 – Parts and Accessories Necessary for Safe Operation

- A *bridle ('Y') system*, with two attachments at the towed vehicle, and one attachment at the towing vehicle. When a single cable is used, a thimble and twin-base cable clamps shall be used to form the front bridle eye.
- *Two pairs of chains/cables*. One pair from the towed vehicle to the rear of the tow-bar. The other pair from the towing vehicle to the front of the tow-bar.
 - The chains/cables must extend beyond any bolts, rivets, etc. used to connect structural members of the tow-bar.
 - For an extendible tow-bar, a stop must be used to prevent separation of the movable part of the tow-bar.

Fixed tow-bar, converter dolly: A single chain/cable may be used down the centerline of the tow-bar. The device may be attached to any location along the tow-bar.

EMERGENCY EQUIPMENT

**Emergency
Equipment
392.8 / 393.95**

CMV's must carry the following emergency equipment:

- Fire extinguisher.
- Spare fuses.
- Warning devices for stopped vehicles.

**Fire Extinguishers
393.95**

Fire extinguishers must be securely mounted and readily accessible. Each extinguisher must have a gauge or other indicator that shows whether the extinguisher is fully charged and a label displaying one of the following Underwriters' Laboratories (UL) ratings:

- One extinguisher - 5 B:C or more.
- Two extinguishers - 4 B:C or more each.
- One extinguisher - 10 B:C or more, if the vehicle is transporting placarded hazardous materials.

Note: Does not apply to vehicles towed in driveaway-towaway operations.

MOTOR CARRIER SAFETY

PART 393 – Parts and Accessories Necessary for Safe Operation

**Warning Devices
for Stopped
Vehicles**
392.22 / 392.24 /
392.25 / 393.95

CMV's must be equipped with one of the following types of warning devices:

- Three reflective triangles.
- At least six fusees or three liquid-burning flares, *except* for vehicles transporting explosives (1.1, 1.2, 1.3), flammable liquid (3) or flammable gas (2.1) in cargo tanks, or compressed gas as a fuel.

Placement of Warning Devices: The three warning devices must be placed as follows (except where special rules apply):

- One on the traffic side, ten feet from the vehicle, in the direction of approaching traffic.
- One 100 feet away from the vehicle in the center of the traffic lane or shoulder where the vehicle is stopped, in the direction of approaching traffic.
- One 100 feet away from the vehicle in the center of the traffic lane or shoulder where the vehicle is stopped, in the direction away from approaching traffic.

**Hazard Warning
Flashers**
392.22

A CMV stopped upon a highway or shoulder must activate the vehicle's hazard warning flashers immediately. The driver must leave the flashers on until the warning devices are in place. The flashers must again be used while the warning devices are being picked up before the movement of the vehicle.

FUEL SYSTEM

**General
Requirements**
393.65

Each fuel system must meet the following requirements: *

- Fuel systems, including fuel tanks and fuel lines, must be properly secured in a workmanlike manner, and be free of leaks.
- No part of the system may extend beyond the widest part of the vehicle.
- No part of the fuel system of a *bus* may be located within or above the passenger compartment.

* See 393.69 for propane systems.

Fuel Lines

Each fuel line must be located so that:

MOTOR CARRIER SAFETY

PART 393 – Parts and Accessories Necessary for Safe Operation

- 393.65**
- The lines do not extend more than 2 inches below the fuel tanks unless the lines are enclosed in a protective housing. Diesel fuel crossover, return, and withdrawal lines which extend below the bottom of the tank must be protected.
 - The lines do not extend between a towed vehicle and the towing unit while the combination is in motion.

Fuel Tanks
393.65 / 393.67

Fuel tanks must meet the following requirements: *

- No part of a fuel tank may be located forward of the front axle of a power unit, or extend beyond the widest part of the vehicle.
- Fuel spilled while fueling must not contact the exhaust or electrical system.
- Fill pipe openings must be located outside the passenger compartment and sealed with a tightly fitted cap.

Drains and bottom fittings:

- Must not extend more than $\frac{3}{4}$ of an inch below the bottom of the fuel tank.
- Must be protected against damage from impact.

* See 393.68 for natural gas containers.

LIGHTS

General Requirements
393.11 / 571.108

FMCSR Part 393.11 and FMVSS Part 571.108 specify the required color, position, and types of lamps and reflectors for CMV's. Requirements are also found in:

- Hazard warning signals – 393.19
- Clearance lamps – 393.22
- Turn signals – 393.22
- Head lamps – 393.24
- Stop lamps – 393.25
- Driveaway-towaway operations – 393.17

Must be Operable
393.9

All required lamps shall be capable of being operated at all times.

Lamp Mounting and Visibility

All lamps must be permanently and securely mounted to the vehicle or projecting load. The lamps must be visible under normal conditions.

MOTOR CARRIER SAFETY

PART 393 – Parts and Accessories Necessary for Safe Operation

392.33 / 393.9 /
393.25

**Conspicuity
Systems**
393.11 / 393.13 /
393.26

Certain vehicles must have retroreflective sheeting or reflex reflectors to make them more visible to other motorists under conditions of reduced visibility.

MISCELLANEOUS PARTS AND ACCESSORIES

**Cab and Body
Components**
393.203

Cab and body components must meet the following requirements:

- *Cab doors and door parts* shall not be missing or broken. Doors shall not sag or be wired shut or secured in the closed position to prevent opening.
- *Bolts or brackets securing the cab* or the body of the vehicle to the frame shall not be loose, broken, or missing.
- *Hood* must be securely fastened.
- *Seats* must be securely mounted.
- *Front bumper* must not be missing, loosely attached, or protruding beyond the confines of the vehicle so as to create a hazard.

Exhaust Systems
393.83 / 393.84

Exhaust systems must meet the following requirements:

- The exhaust system and discharge must be located where they are not likely to damage the electrical wiring, the fuel supply, nor any combustible part of the vehicle.
- The discharge from the exhaust system must not be located immediately below the fuel tank or the fuel tank filler pipe.
- The exhaust system may not be temporarily repaired with patch or wrap material.
- The exhaust pipe and mufflers must be securely fastened to the vehicle.
- The exhaust system may not leak or discharge at any point forward of or directly below the driver or sleeper compartment. Floors must be substantially constructed and free of holes that allow entrance of fumes and gases.

Location of discharge:

Trucks and truck tractors: Must discharge at a location to the rear of the

MOTOR CARRIER SAFETY

PART 393 – Parts and Accessories Necessary for Safe Operation

cab, or above and near the rear of the cab.

Buses, gasoline-powered: Must discharge at or within 6 inches forward of the rearmost part of the bus.

Buses, other fuels: Must discharge either:

- At or within 15 inches forward of the rearmost part of the bus, or
- To the rear of all doors or windows designed to be open (not including emergency exits).

Frames 393.201

Frames, crossmembers, and securement devices (bolts, etc.) shall not be cracked, loose, sagging, broken, or missing. No holes shall be drilled in the top or bottom rail flanges, nor shall any welding be done on the frame or chassis, except as specified by the manufacturer.

Rear End Protection 393.86

Every CMV must be equipped with a rear impact guard, bumper, or other device that prevents the under ride of another vehicle. The impact guard must be substantially constructed and attached to the vehicle. The dimensions and locations required are based on the date the impact guard was manufactured. *

* Does not apply to truck-tractors (390.5), pole trailers (390.5), pulpwood trailers (393.5), low chassis vehicles (393.5), special purpose vehicles (393.5), wheels back vehicles (393.5), and driveway-towaway operations (390.5).

Impact Guard Measurements	Code ¹	Manufactured before 1/26/98 ²	Manufactured on or after 1/26/98 ³
Width	A	18" max.	4" max.
Height	B	30" max.	22" max.
Rear Surface	C	24" max.	12" max.
Cross-Sectional Vertical Height	D	n/a	3.94" min.

MOTOR CARRIER SAFETY

PART 393 – Parts and Accessories Necessary for Safe Operation

- ¹ Letters correspond with the measurements labeled in the figures below.
- ² Impact guard required only when the height from the ground to the vehicle chassis is greater than 30” when the vehicle is empty.
- ³ Impact guard must be labeled under specifications in 393.86(a)(6) / 571.223.

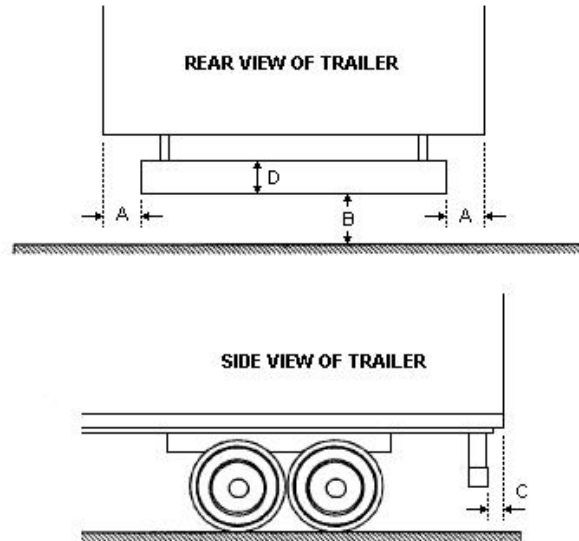

Seat Belts
392.16 / 393.93 /
ORS 811.210 /
815.055

CMV's must be equipped with seats, seat belt assemblies, and seat belt anchorages as specified in FMVSS Part 571. A driver must not drive before correctly restraining him/herself.

Sleeper Berths
393.76

Sleeper berths must meet minimum dimension requirements. They must not be installed in or on a trailer and must be located in or adjacent to the cab. An exit doorway or opening must be at least 18 inches high by 36 inches wide, and must lead directly into the cab.

Each sleeper berth must be equipped with an adequate mattress, bed clothing, and blankets. The sleeper berth must be properly ventilated and located so as to protect occupants against exhaust heat, fumes, fuel leaks, dust, and rain. A means must be provided to prevent ejection of the occupants from the sleeper berth during vehicle deceleration.

MOTOR CARRIER SAFETY

PART 393 – Parts and Accessories Necessary for Safe Operation

Steering System 393.209

Steering systems must be in proper working order, including the following:

- *Steering wheel* must be properly secured and not have any cracked or missing spokes. The steering wheel shall turn freely in both directions.
- *Steering wheel lash (free play)* must not exceed certain parameters.
- *Steering column* must be securely fastened.
- *Steering gear box* must be securely attached and not cracked. The pitman arm must not be loose on the steering gear output shaft. The yolk-coupling of the steering column must not be loose on the steering gear input shaft.
- *Attachments*, including ball and socket joints, universal joints, clamps, bolts, and nuts, shall not be worn, loose, or welded.
- *Tie rods and drag links* shall not be worn or bent.
- *Power steering systems* must not have loose or broken parts; frayed, cracked, or slipping belts; leaks; or insufficient fluid in the reservoir.

Suspension System 393.207

Suspension systems must be structurally sound and in proper working order, including the following:

- *Axles* must be in proper alignment, and no positioning part shall be cracked, broken, loose, or missing.
- *Adjustable axles* must have locking pins in place.
- *Leaf springs* must not be cracked, broken, missing, nor shifted out of position.
- *Coil springs* must not be cracked or broken.
- *Torsion bars* must not be cracked or broken.
- *Air suspensions* must support the vehicle in a level position, and must not leak.

Tires 393.75

Tires used on CMV's must meet specific safety standards. No tire may have any of the following defects:

- Body ply or belt material cut or otherwise exposed through the tread or sidewall.

MOTOR CARRIER SAFETY

PART 393 – Parts and Accessories Necessary for Safe Operation

- Tread or sidewall separation.
- Flat or audible leak.
- Have less than the minimum tread depth:
 - Front axle: 4/32 inch minimum.
 - Other axles: 2/32 inch minimum.
- Carry a weight greater than the rated capacity for that tire. This includes an underinflated tire.
- Mounted or inflated so that it comes in contact with any part of the vehicle, including an adjacent tire.
- *Front axle:*
 - Regrooved tires on trucks or truck tractors which have a load-carrying capacity equal to or greater than 4,920 lbs.
 - Mixing bias and radial tires on the same axle.
 - Regrooved, recapped, or retreaded tires on buses.

Wheels 393.205

Wheels must meet the following conditions:

- *Wheels, rims, and hubs* shall not be cracked or broken.
- *Stud or bolt holes* shall not be elongated (out of round).
- *Nuts or bolts* shall not be missing or loose.
- *Lock or side rings* shall not be bent, broken, cracked or improperly seated.

Windshields 393.60 / 393.78 / 393.79

A vehicle's windshield (includes both left and right sides, if split windshield) must be free of discoloration, intersecting cracks, and damage greater than ¾ inch in diameter. The wipers and the defroster must be in proper working order.

Affected area:

Lowest: Top of the steering wheel.

Highest: 2 inches below top of the windshield.

Sides: 1 inch from left and right sides of each windshield.

MOTOR CARRIER SAFETY

PART 393 – Cargo Securement

CARGO SECUREMENT

General Requirement 393.100 / 393.106	The cargo loaded on a CMV must be contained or secured to prevent the load from leaking, blowing, falling from the vehicle, or shifting to an extent that would affect the vehicle's stability. Cargo likely to roll must be restrained by chocks, cradles, or other devices to prevent rolling.
Securement System Standards 393.104 / 393.112	All securement devices and systems (tiedowns, anchor points, walls, stakes, chocks, etc.) must be in good working order, properly secured, and free of damage that would adversely affect the cargo securement. Tiedowns must meet certain manufacturing standards. Edge protection (<i>defined in 393.5</i>) must be used wherever a tiedown would be subject to abrasion or cutting.
Cargo Inspection 392.9	The driver must ensure that the cargo is properly distributed and secured. Accessory equipment (tarps, tailgate, spare tire, etc.) must also be secured. The driver must examine and adjust/change the cargo securement, as necessary: <ul style="list-style-type: none">• Before driving.• Within the first 50 miles.• At the next change of duty status, after 3 hours of driving, or after driving 150 miles, whichever occurs first.
Working Load Limit 393.5 / 393.102 / 393.106 / 393.108	Working load limit (WLL) is the maximum load that may be applied to a component of a cargo securement system during normal service. The securement devices must have an <i>aggregate WLL (defined in 393.5)</i> capable of preventing cargo movement in the forward, rearward, sideways, and vertical directions. The WLL of a tiedown is determined by the manufacturer's markings or, if not available, by the WLL tables in 393.108.

Indirect Securement

The tiedown goes from an anchor point on the vehicle, through, over, or around the cargo and attaches to another anchor point on the *other side* of the vehicle.

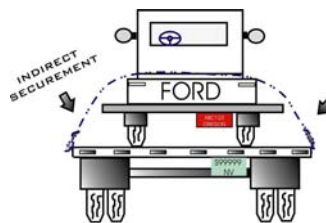

The assigned WLL is the entire WLL determined by the manufacturer's marking or by the WLL tables.

Direct Securement

MOTOR CARRIER SAFETY

PART 393 – Cargo Securement

- The tiedown goes from an anchor point on the vehicle to an attachment point on the cargo, or
- The tiedown goes from an anchor point on the vehicle, through, over, or around the cargo and attaches to another anchor point on the *same side* of the vehicle.

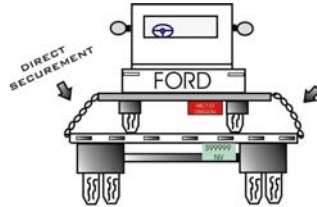

The assigned WLL is **one-half** of the WLL determined by the manufacturer's marking or by the WLL tables.

The assigned *aggregate* WLL of all devices used to secure cargo must be at least one-half times the **weight** of the cargo. For example, if the cargo weighs 30,000 lbs., the assigned *aggregate* WLL of all devices used to secure the cargo must be at least 15,000 lbs.

General Provisions 393.110

The number of tiedowns required to secure cargo is also dependent on the **length** of the cargo.

If no front end structure or cargo to prevent forward movement:

Length of Cargo	Weight of Cargo	Minimum Number of Tiedowns
5 ft. or less	1,100 lbs. or less	1
	Over 1,100 lbs.	2
Over 5 ft. up to 10 ft.	n/a	2
Over 10 ft.	n/a	2 tiedowns for first 10 ft., plus - 1 tiedown for each extra 10 ft. length or fraction thereof. <i>Example: 25 ft. = 4 tiedowns.</i>

MOTOR CARRIER SAFETY

PART 393 – Cargo Securement

With front end structure or cargo to prevent forward movement: *

1 tiedown for each 10 ft. length or fraction thereof.

Example: 25 ft. = 3 tiedowns.

* *See 393.114 for front end structure requirements.*

Special Purpose Vehicles 393.5 / 393.110

The length requirements of 393.110 do not apply to vehicles transporting cargo which, because of its design, size, shape, or weight, must be secured by special methods. However, the cargo must be properly secured.

Examples: Crane booms, trusses, boats.

Commodity- Specific Rules 393.106

Additional rules apply to certain types of cargo, and take precedence over the general requirements. **Bolded** items are described in more detail below.

- **Logs – 393.116**
- **Dressed lumber or similar building products – 393.118**
- Metal coils – 393.120 (*defined in 393.5*)
- Paper rolls – 393.122
- Concrete pipe – 393.124
- **Intermodal containers – 393.126**
- Automobiles, light trucks, and vans – 393.128
- **Heavy vehicles, equipment, and machinery – 393.130**
- **Flattened or crushed vehicles – 393.132**
- Roll-on/roll-off or hook lift containers – 393.134 (*defined in 393.5*)
- Large boulders – 393.136
- **Baled hay and straw**

Logs¹ 393.116

The following applies to all loads of five or more logs. Loads of less than 5 logs may be secured under the general requirements of 393.100 to 393.114:²

- The logs must be solidly packed and cradled with bunks or stakes (A) to prevent the logs from rolling.
- The outer bottom logs (B) must rest solidly against the bunks or stakes.
- Each outside log (C) must have one end touching a bunk or stake, and the other end touching, or at least extending beyond, the other

MOTOR CARRIER SAFETY

PART 393 – Cargo Securement

bunk or stake.

- The center of each highest outside log (**D**) must be below the top of each bunk or stake.
- The logs must be secured by *two* tiedowns or wrappers with the following exceptions:
 - Logs 27 feet or longer: Require *four* evenly-spaced wrappers (**E**) (OR OSHA rule, OAR 437-007-1010).
 - Shortwood loaded lengthwise: Allowed *one* tiedown/wrapper for any middle stack blocked in the front and rear by structures or other shortwood stacks.³
- The aggregate WLL of all tiedowns/wrappers used to secure the logs loaded on a flatbed or frame vehicle (*defined in 393.5*) must be at least **1/6** times the total weight of the logs.

¹ “Logs” include round processed wood (e.g., utility poles, peeler cores).

² See 393.116 for additional rules for pole trailers and shortwood logs loaded crosswise.

³ “Shortwood” - logs up to 16 feet in length (393.5).

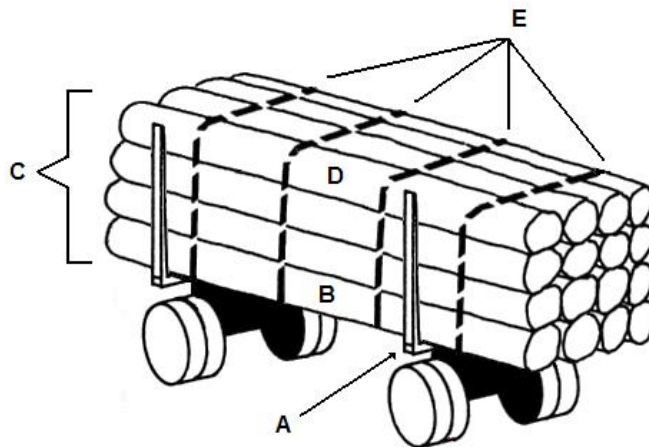

MOTOR CARRIER SAFETY

PART 393 – Cargo Securement

**Dressed Lumber or
Similar Building
Products
393.118**

Bundles one or two tiers high

Bundles must be secured with tiedowns over the **top tier**.

Bundles three or more tiers high

Bundles require tiedowns over the **top tier**, **plus one** of the following:

- *Stakes* on the vehicle sides to prevent lateral movement; or
- *Blocking* or *friction devices* between tiers to prevent lateral movement; or
- *Tiedowns over the middle tier*. If more than 3 tiers, the maximum height of the middle tier that is secured may not exceed 6 feet above the deck of the vehicle; or *
- *Tiedowns over the second tier* from the bottom; or *
- *Tiedowns over each tier*; or
- Loaded in a *sided vehicle* (defined in 393.5) or *container* of adequate strength (*does not include curtain vans or tautliners*).

Note: *All tiedowns required above must be secured under the general requirements of 393.100 to 393.114. At least two tiedowns are required for bundles two or more tiers high and longer than 5 ft.*

Note: *393.118 does not apply to veneer or non-bundles such as glue-laminated beams. Veneer and glue-laminated beams must be secured with tiedowns over the top tier under the general requirements of 393.100 to 393.114.*

* Note: *Spacers are allowed under the specifications in 393.118(d)(3).*

MOTOR CARRIER SAFETY

PART 393 – Cargo Securement

Intermodal Containers 393.126

Container chassis vehicle (defined in 393.5)

- Each container must be secured to the chassis with securement devices or integral locking devices at all lower corners that cannot come open while the vehicle is in transit. The front and rear of the container must be secured independently.
- The securement devices must not allow the container to shift in any direction more than ½ inch.

Loaded container on non-chassis vehicle

- All lower corners of the container must rest upon the vehicle.
- The container must be secured by *one* of the following:
 - Chains, wire ropes, or locking devices fixed to all lower corners, or
 - Crossed chains fixed to all upper corners.
- The container must be secured to the vehicle with devices that cannot come open while the vehicle is in transit. The front and rear of the container must be secured independently.

Empty container on non-chassis vehicle

The container need not have all lower corners resting on the vehicle, provided:

- The container is balanced on the vehicle.
- The container does not overhang more than 5 feet at the front or rear of the vehicle, and does not interfere with the vehicle's maneuverability.
- The container is secured to prevent shifting in any direction.

MOTOR CARRIER SAFETY

PART 393 – Cargo Securement

Heavy Vehicles, Equipment, and Machinery 393.130

The following applies to vehicles, equipment, and machinery individually weighing 10,000 lbs. or more. Loads less than 10,000 lbs. may be secured according to the general requirements of 393.100 to 393.114, or 393.128:

- Equipment with crawler tracks or wheels must be secured with at least four tiedowns, attached as close as possible to the front and rear of the vehicle. *
- Accessory equipment (e.g., shovels, buckets) must be lowered and secured to the vehicle, or lowered and locked in place to prevent shifting during transport.
- Articulated vehicles must be restrained to prevent articulation while in transit.

* *The following securement arrangements are also permitted:*

Two individual tiedowns sharing one anchor point on the equipment, or one anchor point on the vehicle, as long as the anchor point is strong enough.



A single chain used as two tiedowns when the chain acts independently on each side of the equipment. Each side of the tiedown must have two attachment points and one adjustment mechanism.



MOTOR CARRIER SAFETY

PART 393 – Cargo Securement

Flattened or Crushed Vehicles 393.132

- Synthetic webbing is not allowed for securing the vehicles, except that webbing may be used to connect wire rope or chain to anchor points on the CMV. However, the webbing may not come in contact with the flattened or crushed vehicles.
- Containment walls, if used, must extend to the full height of the load, and must block against cargo movement.
- The containment system must prevent liquids from leaking, and loose vehicle parts from falling, from the flattened or crushed vehicles.
- There are four options for securement:

Containment Walls	Tiedowns Per Vehicle Stack
All 4 sides	0
3: front, rear, and one side	2
2: front and rear	3
none	4

MOTOR CARRIER SAFETY

PART 393 – Cargo Securement

**Baled Hay and
Straw
393.102(c):
FMCSA
Memorandum**

The following meets or exceeds the performance requirements of the FMCSR. Tiedowns are exempt from the aggregate WLL found in 393.106(d), provided they meet the WLL requirements below.

Bale Placement

Loads must be well-balanced and positioned on the vehicle so the load is stable without tiedowns.

Small bales (see first diagram below)

- *Sides of load:* Outside bales must not be placed in the same direction in more than two successive tiers (**A**), except one bale above and below a tier, up to three tiers in succession (**B**).
- Bales in the top tier must be loaded crosswise to the vehicle (**C**).
- No bale must be loaded vertically.

Big bales

Sides of load: Outside bales must not be placed in the same direction in more than three successive tiers.

Load projection

No bales may extend beyond the vehicle bed between a truck and trailer, or semi-trailer and trailer. No bales may extend more than one-third the bale length beyond the rear of the bed surface on a single vehicle or the last vehicle in a combination of vehicles. Bales may extend over the truck cab provided they are supported, interlocked with other bales, and do not obstruct the driver's view.

Longitudinal Tiedowns

The load must be unitized with two longitudinal tiedowns, each having a minimum WLL of 2,100 lbs., and secured with a tightening device (**F, I**). The tiedowns must be applied over V-boards (**E**), or big bales may use the alternate method below.

MOTOR CARRIER SAFETY

PART 393 – Cargo Securement

With V-Boards

(big or small bales)

Two tiedowns must be anchored at the front and rear near the corners (**D**), extended over the top, and crossed or connected with a tightening device at the center (**F**).

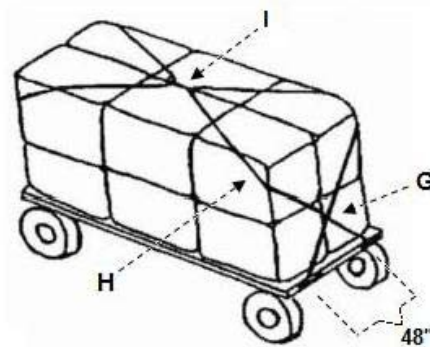
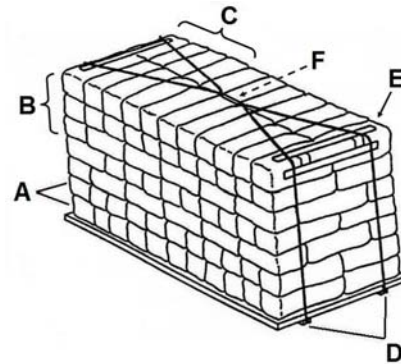

Alternate securement (big bales)

Two tiedowns must be anchored at the front and rear of the load at least 48 in. apart, crossed at the front and rear (**G**), passed to the outside around the upper corners of the load (**H**), and connected with a tightening device at the top center (**I**).

Lateral Tiedowns

Each tiedown must have a minimum WLL of 4,000 lbs. Multiple tiedowns may be substituted, provided each has a minimum WLL of 625 lbs., with a combined WLL of 4,000 lbs. or more. Tiedowns less than 2 inches in width or diameter must include V-boards.

Vehicles 32 feet or less in length

One tiedown shall be placed in the center of the length of the vehicle.

Vehicles greater than 32 feet in length

Two tiedowns shall be positioned at one-third and two-thirds the length of the vehicle.

Note: Bales not unitized by longitudinal tiedowns must be secured according to the general cargo securement requirements of FMCSR, 393.100-114.

Note: For further information, visit ODOT's website at: www.oregon.gov/ODOT/MCT/docs/HaySecurement.pdf.