

IMPACT OF VARIATIONS IN MATERIAL PROPERTIES
ON ASPHALT PAVEMENT LIFE-
EVALUATION OF WARREN-SCAPPOOSE PROJECT
INTERIM REPORT
HPR Study 081-5157

by

Jean L. Walter
Research Assistant
Oregon State University

R. G. Hicks
Professor of Civil Engineering
Oregon State University

James E. Wilson
Assistant Engineer of Materials
Oregon Department of Transportation

December 1981

1.0 INTRODUCTION

Problem Definition

Several changes have occurred in recent years, in the type of highway materials, and in the asphalt paving technology. New asphalt sources have been brought on line, introducing changes in asphalt properties. New equipment have also been developed, affecting mixing (dryer drum mixers, more efficient dust collector systems), storage (mix storage silos) and compaction (vibratory compactors). In the same period, economical constraints have resulted in increasing use of lower quality aggregate. As a result, there has been an increase in construction or short-term performance problems throughout the Pacific Northwest (1). The impact of such changes on the mix properties is, however, difficult to evaluate. Table 1 summarizes the main changes observed and their expected influence on the mix behavior.

A recent project is located on the Columbia River Highway between Warren and Scappoose. The base course was constructed in 1979 and the wearing surface in 1980. Progressive pavement raveling and potholing were noticed in the base course during the months following construction. Evaluation of the reduction in pavement life resulting from the variations in mix and pavement properties (e.g., aggregate quality, gradation, density, asphalt content) resulted in a study of the mix dynamic properties under controlled conditions. A new approach was used to assess the effects of these mix variables on pavement life.

Purpose

The purpose of this report is to obtain a better understanding of the causes of the pavement problems noticed in recent years, and to develop relationships between pavement performance and the different mix variables. Such information will be useful in developing pay-adjustment factors for projects not complying fully with specifications.

Table 2 illustrates a flow chart of the approach followed for the study of the Warren-Scappoose project. Five mix variables were considered in the study:

- (1) Asphalt content.
- (2) Percent Passing No. 200 sieve (.074 mm).
- (3) Percent Passing No. 10 sieve (2.00 mm).
- (4) Mix density.

The range of values selected for each of the above variables was determined

LIST OF FIGURES

- Figure 1 Map of Northwest Part of Oregon.
- Figure 2 Warren-Scappoose Map. Detail of Project Location.
- Figure 3 Pavement Cross-Section
- Figure 4 Core Gradation, Top Layer.
- Figure 5 Core Gradation, Base Layer.
- Figure 6 Diametral Test Apparatus.
- Figure 7 Diametral Test-Variables Recorded.
- Figure 8 Schematic View of the Automatic Shut-Off Device for Fatigue Testing.
- Figure 9 Sample at End of Fatigue Test.
- Figure 10 Influence of Bulk Specific Gravity on Resilient Modulus - As Compacted Samples.
- Figure 11 Influence of Amount of Fines on Resilient Modulus - As Compacted Samples.
- Figure 12 Influence of Bulk Specific Gravity on Resilient Modulus - Conditioned Samples.
- Figure 13 Influence of Amount of Fines on Resilient Modulus - Conditioned Samples.
- Figure 14 Relationship Between k and m .
- Figure 15 Influence of Mix Density on Fatigue Life.
- Figure 16 Influence of Asphalt Content on Fatigue Life.
- Figure 17 Influence of Passing No. 200 on Fatigue Life - 4.5% Asphalt Content.
- Figure 18 Influence of Passing No. 200 on Fatigue Life - 6.5% Asphalt Content.
- Figure 19 Permanent Deformation Results for Six Samples.
- Figure 20 Relationship Between Permanent Deformation Intercept and Horizontal Tensile Strain.
- Figure 21 Relationship Between Permanent Deformation Intercept and Horizontal Tensile Strain for a Constant Slope = .503.
- Figure 22 Influence of Mix Density on Permanent Deformation.
- Figure 23 Influence of Asphalt Content on Permanent Deformation, 6% Passing No. 200.
- Figure 24 Influence of Asphalt Content on Permanent Deformation, 2 and 10% Passing No. 200.
- Figure 25 Influence of Passing No. 200 on Permanent Deformation - 4.5% Asphalt Content.
- Figure 26 Influence of Passing No. 200 on Permanent Deformation - 6.5% Asphalt Content.
- Figure 27 Relationship Between Mix Resilient Modulus and Indirect Tensile Strength.

LIST OF TABLES

- Table 1 Recent Changes in Asphalt Technology Affecting Mix Behavior.
- Table 2 Flow Chart of Study.
- Table 3 Original Mix Design.
- Table 4 Mix Design: Aggregate Gradation.
- Table 5 Summary of Daily Plant Report.
- Table 6 Comparison Between Construction Information, Core Data and Mix Specification.
- Table 7 Summary of Mix Design.
- Table 8 Core Data - Warren-Scappoose.
- Table 9 Test Program - OSU.
- Table 10 Range of Mix Variables Considered in This Study.
- Table 11 Resilient Modulus Data.
- Table 12 Fatigue Data.
- Table 13 Fatigue Data - Corrected Values.
- Table 14 Permanent Deformation Constants - As Compacted Samples.
- Table 15 Permanent Deformation Data.
- Table 16 Indirect Tensile Strength Test Data.
- Table 17 Estimated Reduction in Pavement Life - Fatigue Criteria - Effect of Mix Density.
- Table 18 Estimated Reduction in Pavement Life - Fatigue Criteria - Effect of Asphalt Content.
- Table 19 Estimated Reduction in Pavement Life - Fatigue Criteria - Effect of P_{200} at 4.5% Asphalt Content.
- Table 20 Estimated Reduction in Pavement Life - Fatigue Criteria - Effect of P_{200} at 6.5% Asphalt Content.
- Table 21 Estimated Reduction in Pavement Life - Permanent Deformation Criteria - Effect of Density.
- Table 22 Estimated Reduction in Pavement Life - Permanent Deformation Criteria - Effect of Asphalt Content.
- Table 23 Estimated Reduction in Pavement Life - Permanent Deformation Criteria - Effect of Passing No. 200, 4.5% Asphalt Content.
- Table 24 Estimated Reduction in Pavement Life - Permanent Deformation Criteria - Effect of Passing No. 200, 6.5% Asphalt Content.
- Table 25 Summary of Most Critical Pay Adjustment Factors.

TABLE OF CONTENTS

	<u>Page</u>
1.0 INTRODUCTION	1
Problem Definition	1
Purpose	1
Scope of Report	3
2.0 PROJECT DESCRIPTION	4
Location	4
Cross Section	4
Mix Design	4
Project Data	4
3.0 TEST RESULTS - ODOT	9
Mix Design Data	9
Core Data	9
4.0 TEST RESULTS - OSU	12
Test Program	12
Test Equipment	12
Test Procedure and Calculations	15
Resilient Modulus Data	19
Fatigue Data	22
Permanent Deformation Data	33
Indirect Tensile Test Data	42
5.0 DEVELOPMENT OF PAY ADJUSTMENT FACTORS	47
Fatigue	47
Permanent Deformation	50
6.0 CONCLUSIONS AND RECOMMENDATIONS	54
7.0 REFERENCES	57
APPENDIX A	

ACKNOWLEDGEMENTS

This report is fourth in a series of reports concerned with the impact of variations in material properties on asphalt pavement life. The authors are grateful for the cooperation of all the agencies which participated in this study. Assistance in the preparation and testing of samples, and in assembling the final report was provided by Jose R. Montalvo and Michael Wynkoop, both students of Oregon State University.

The project was conducted in cooperation with the U.S. Department of Transportation Federal Highway Administration.

DISCLAIMER

The contents of this report reflect the views of the authors who are responsible for the facts and the accuracy of the data presented herein. The contents do not necessarily reflect the official views or policies of either the Oregon Department of Transportation or the Federal Highway Administration.

1. Report No. FHWA - OR-81-7		2. Government Accession No.		3. Recipient's Catalog No.	
4. Title and Subtitle "Impact of Variations in Material Properties on Asphalt Pavement Life - Evaluation of Warren-Scappoose Project"				5. Report Date December 1981	
				6. Performing Organization Code	
7. Author(s) Jean L. Walter, R. G. Hicks and James E. Wilson				8. Performing Organization Report No. TE-81-9	
9. Performing Organization Name and Address Oregon State University Department of Civil Engineering Corvallis, OR 97331				10. Work Unit No. (TRAIS) HPR 081-5157	
				11. Contract or Grant No.	
12. Sponsoring Agency Name and Address Oregon Dept. of Transportation Materials & Research Sec. Salem, OR 97310				13. Type of Report and Period Covered Interim	
				14. Sponsoring Agency Code	
15. Supplementary Notes					
16. Abstract <p>Construction and short-term pavement performance problems were noted in the Pacific Northwest and throughout the United States during the past five years. Several reasons have been suggested to explain this sudden change in pavement performance, such as recent variabilities in asphalt properties and new developments in paving technology.</p> <p>Using the data and construction materials from a recent project built in 1979-80, Oregon State Highway Division and Oregon State University initiated a laboratory study to determine the relationship between asphalt concrete pavement performance and mix level of compaction, asphalt content, and percent passing No. 200 sieve.</p> <p>Conventional tests and improved dynamic tests were run on laboratory compacted samples to determine mix stiffness, fatigue life and permanent deformation characteristics. Based on fatigue and permanent deformation test results, pay adjustment factors were developed by comparing performance of mix prepared at the design optimum with the performance of mix out of specifications. It was found that performance is primarily affected by the mix level of compaction. The design optimum asphalt content was corroborated by the fatigue data. A decrease in mix performance was observed when the amount passing the No. 200 sieve was decreased to 2%. Above the design optimum amount of fines, the mix performance increased proportionally to the asphalt content, showing a strong interaction fine-asphalt content.</p> <p>A summary table giving the most critical pay adjustment factors between the fatigue and the permanent deformation criteria is developed in the conclusion and recommendations chapter.</p>					
17. Key Words Asphalt concrete, pay adjustment factors, aggregate quality			18. Distribution Statement No restrictions		
19. Security Classif. (of this report) Unclassified		20. Security Classif. (of this page) Unclassified		21. No. of Pages 62	22. Price

Table 1. Recent Changes in Asphalt Technology Affecting Mix Behavior.

ITEM	CHANGES OBSERVED	EXPECTED IMPACT ON MIX
ASPHALT	Wide difference between asphalt temperature-viscosity curves from various suppliers	Incompatible mixes Slow setting mixes
	Compatibility between asphalt and aggregate	Low mix cohesion
AGGREGATE	Reduced aggregate quality	Low mix cohesion from water effect
	Single stockpile Elimination of Plant Screens	Non-uniformity of mix gradation
EQUIPMENT	Efficient dust collection systems	Low mix cohesion
	High mix production rate	Uniformity of mix reduced
	Lower mixing and laydown temperatures	Effect on asphalt viscosity reduced excess moisture reduces asphalt bond
	Vibratory compactor	Breakage of aggregates Low compaction from improper use
	Drum mixers - mix storage silos	Incomplete coating of aggregate Mix segregation from improper use

Table 2. Flow Chart of Study.

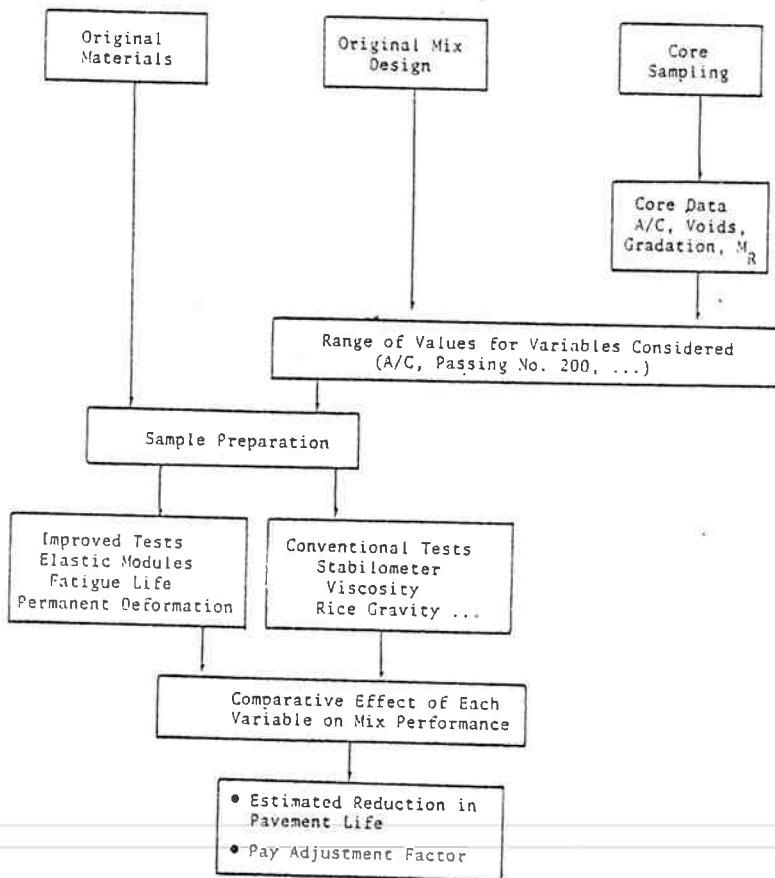

from construction records and from cores taken in the Fall of 1980. These are as follows:

- (1) Asphalt content: 4.5% - 5.5% - 6.5%
- (2) Percent Passing No. 200: 2% - 6% - 10%
- (3) Percent Passing No. 10: 25% - 30% - 35%
- (4) Mix Level of Compaction: 100% - 97% - 93% - 90%

Following the standard ODOT procedure, 4 inches (10 cm) in diameter by 2.5 inches (6.5 cm) high samples were prepared, for each set of conditions, using the same materials (asphalt and aggregate) as used during construction of the Warren-Scappoose project.

The main types of pavement failure considered during the test program include fatigue cracking and rutting. All samples are tested in the diametral mode for elastic modulus, fatigue life and permanent deformation. To obtain complete characterization of the mixture, conventional tests were also run (stabilometer, void content, index of retained strength).

To identify the potential for stripping and ravelling, elastic modulus, fatigue life and permanent deformation tests are performed both before and after vacuum saturation of the samples, followed by a freeze-thaw cycle.

Scope of Report

After a description of the Warren-Scappoose project (Chapter 2), the test results will be presented in Chapter 3 (ODOT research) and in Chapter 4 (OSU research). Tests performed by Oregon Department of Transportation include conventional tests. All dynamic tests were performed at Oregon State University. Analysis of data include the development of fatigue life and permanent deformation criteria for the as-compacted samples and the conditioned samples. Finally, pay adjustment factors are determined in Chapter 5 using the fatigue and permanent deformation models developed in Chapter 4.

2.0 PROJECT DESCRIPTION

Location

The Warren-Scappoose project is a section of the Columbia River Highway, located in Columbia counties (Figure 1). Precise location of the project is shown on Figure 2. The project overall length is 5.05 miles (8.13 km).

Cross-Section

This section of the Columbia River highway includes an asphalt concrete base course and an asphalt concrete wearing surface, on top of a lime treated subgrade and a cement treated base. Both asphalt concrete layers were built using a class B mix. A typical cross-section of the pavement is shown on Figure 3.

Mix Design

A summary of the original mix design is presented in Table 3. This mix design was used for both the base and the top layers. The aggregate gradation was also the same for both layers, and correspond to a type B mix (Table 4). The recommended asphalt content was 5.1 percent for the wearing surface and 5.7 percent for the base course. The asphalt grade recommended was an AR 4000, from Shell. The recommended mix temperature at time of placement was 270°F (132°C).

Project Data

The base course asphalt content constructed in 1979 contained numerous sections with deficiencies of five aggregate and/or asphalt content. Considerable ravelling of the pavement occurred during the winter prior to placement of the wearing surface. Several sections of base course paving were removed and replaced with suitable mix prior to wearing course construction.

Table 5 summarizes the field test results run during pavement construction. The variables considered are the mix bulk specific gravity, asphalt content and percent passing No. 200 and No. 10. Compared to the core data and the specified job mix tolerances (Table 6), it appears from the average field data that the asphalt content and the amount passing No. 200 sieve were low and the amount passing No. 10 was high but reasonably within specifications.

Table 5 also indicates that the mix variables were ranging within a very wide band, indicating quality control problems during mixing (asphalt content, gradation) and during compaction (mix bulk specific gravity). This is corroborated by the ODOT inspector's report who noted that the contractors quality control was nonexistent, production erratic and workmanship sloppy.

BEGINNING OF PROJECT

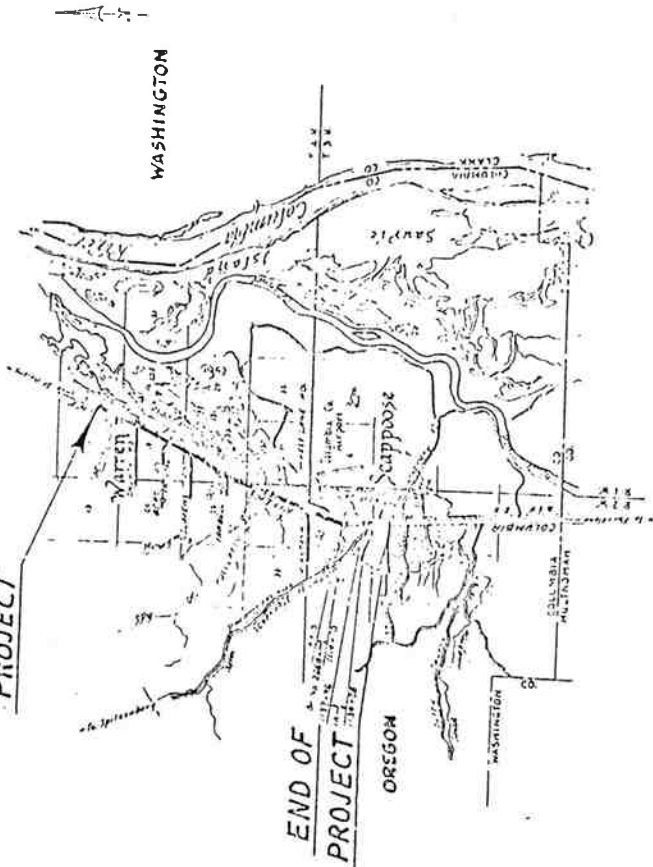

Sketch Map
Scale 0 1 2 Miles

Figure 2. Warren-Scappoose
Detail of Project Location

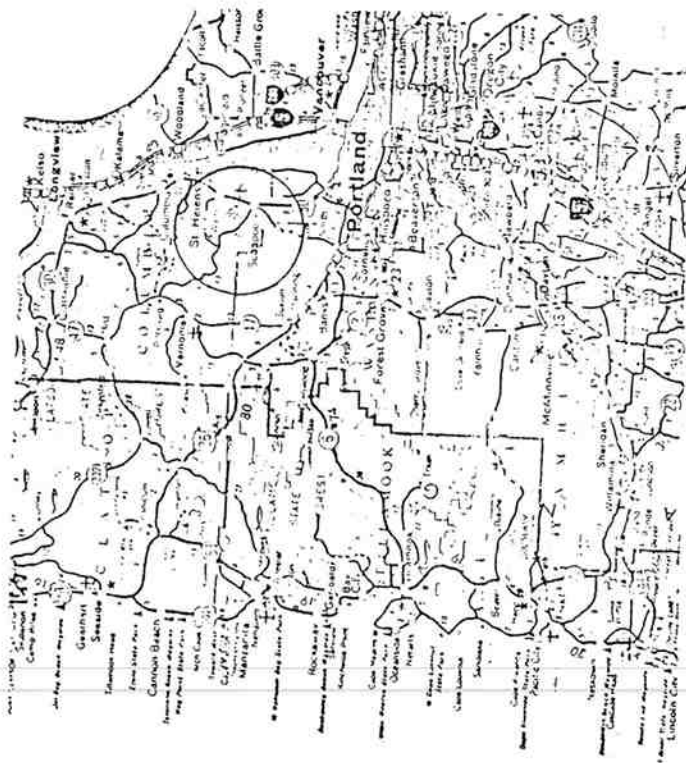

Figure 1. Map of Northwest Part of Oregon Project
Location.

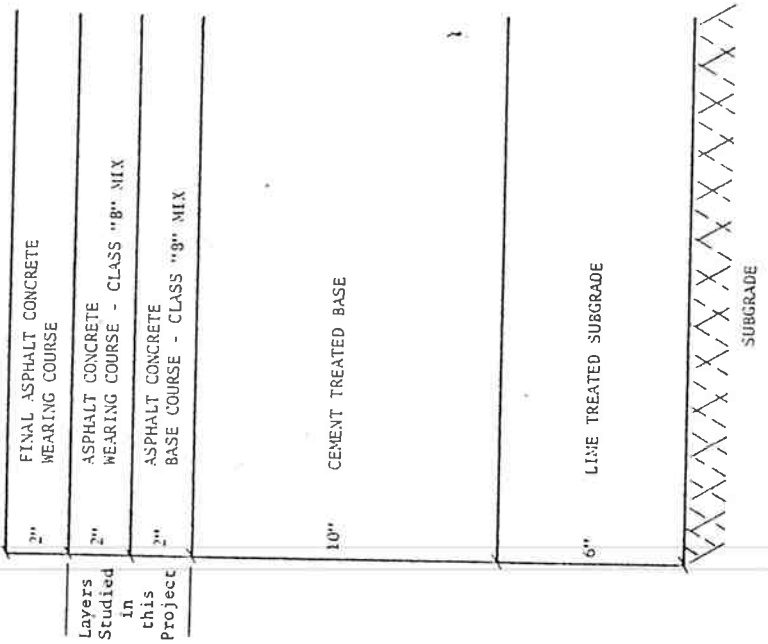

Table 3. Original Mix Design (0001) Test Data
Warren Scappoose Project

	4.5	5.0	5.5	6.0	6.5
Asphalt Content - Shell AR 4000					
Asphalt Film Thickness	Suff.	Suff.	Suff.	Suff. Thick	Thick
Stability Value, 1st Compaction	47	39	40	41	37
Bulk Spe. Gravity, 1st Compaction	2.30	2.33	2.35	2.37	2.39
Percent Voids, 1st Compaction	9.1	7.2	5.6	4.0	2.8
Stability Value, 2nd Compaction	50	45	47	49	34
Bulk Spe. Gravity, 2nd Compaction	2.39	2.41	2.43	2.45	2.46
Percent Void, 2nd Compaction	5.5	4.0	2.4	.8	0.0
Rice Gravity	2.53	2.51	2.49	2.47	2.46
Index of Retained Strength AASHTO-T-105	90	-	93	-	100+

Figure 3. Warren-Scappoose Project
Pavement Cross-Section

Table 4. Mix Design: Aggregate Gradation, Class B

SIEVE SIZE	DRY SIEVE AASHTO-T-27	WASHED SIEVE AASHTO-T-11	JOB MIX TOLERANCE	SPECIFICATION
1"	100	100	100	100
3/4"	98	98	92-100	95-100
1/2"	98	88	82- 94	-
3/8"	79	79	73- 85	-
1/4"	60	60	54- 66	52- 72
# 4	51	51	46- 56	-
# 10	30	30	26- 34	21- 41
# 40	12	12	8- 16	8- 24
#200	4.6	4.8	2.6- 6.6	3-7

Table 5. Summary of Daily Plant Report - 1980 Base and Top Lift
Bikuminous Mix Class "B"

IN PLACE MIX DATA	TOP LIFT		BASE LIFT	
	Average Value	Max. and Min. Values	Average Value	Max. and Min. Values
Mix Bulk Specific Gravity	2.17 ± .05 (29 tests)	2.08 - 2.27	2.24 ± .03 (25 tests)	2.18 - 2.29
Asphalt Content	5.15 ± .11 (36 tests)	4.90 - 5.50	5.65 ± .40 (20 tests)	4.5 - 6.90
Percent Passing No. 200	5.25 ± .62 (38 tests)	4.2 - 6.5	5.22 ± .62 (29 tests)	3.6 - 6.5
Percent Passing No. 10	30.9 ± 2.5 (38 tests)	25 - 35	29.6 ± 3.4 (29 tests)	20 - 34

Table 6. Comparison Between Construction Information, Core Data and Mix Specification

	TOP LIFT			BASE LIFT		
	Daily Plant Test Results	Core Data	Job Mix Tolerance	Daily Plant Test Results	Core Data	Job Mix Tolerance
Mix Bulk Specific Gravity	2.17	2.19	-	2.24	2.28	-
Asphalt Cement	5.15	5.4	4.6 - 5.6	5.65	5.8	5.2 - 6.2
Percent Passing No. 200	5.25	6.35	3 - 7	5.22	7.1	3 - 7
Percent Passing No. 10	30.9	29.95	26 - 34	29.6	31.5	26 - 34

Table 7. Summary of Testing for Mix Design Properties - Warren-Scappoose

MIX TYPE	2% PASSING NO. 200			6% PASSING NO. 200			10% PASSING NO. 200		
	4.5	5.5	6.5	4.5	5.5	6.5	4.5	5.5	6.5
Asphalt Content	4.5	5.5	6.5	4.5	5.5	6.5	4.5	5.5	6.5
Rice Grav. T 209	2.52	2.48	2.46	2.53	2.49	2.45	2.52	2.49	2.47
1st Bulk Spe. Grav.	2.28	2.32	2.36	2.34	2.38	2.40	2.39	2.41	2.43
Voids, %	9.5	6.5	4.1	7.5	4.4	0.2	5.2	5.2	1.6
2nd Bulk Spe. Grav.	2.31	2.37	2.44	2.39	2.43	2.45	2.43	2.45	2.47
Voids, %	8.3	4.4	.8	5.5	2.4	0.0	3.6	1.6	0.0
Modulus x 10 ³ psi	532	424	309	813	685	597	774	690	514
Stability 1st	44	46	43	43	43	45	41	41	14
Stability 2nd	49	48	51	50	50	46	52	49	12

3.0 TEST RESULTS - ODOT

The Oregon State Highway Division testing program included the conventional tests such as standard mix design, recovered aggregate gradation, asphalt content and asphalt properties. This chapter presents the results of their work for the evaluation of the effect of mix variations on mix design properties.

Mix Design Data

The results of tests for mix design properties are presented in Table 7. For each set of variables, standard samples were tested to determine mix characteristics. The percent voids of all samples prepared for this project were determined using the Rice gravities indicated on Table 7. Modulus and bulk specific gravities shown on this table were used as reference values during sample preparation at Oregon State University.

Core Data

At two locations, 5 asphalt concrete cores were sampled across the panel. Table 8 summarizes the results of the tests run on a total of 20 core samples (10 surface and 10 base). The gradation limits shown for each aggregate size are average values, plus and minus the standard deviation. Shown on Figures 4 and 5 are the aggregate gradation for the surfacing and the base mixes, along with the job mix tolerances. The base course contains excess passing No. 200 and both mixes contain excess passing the 1/4-inch sieve for a considerable amount of the paving.

Table 8. Core Data - Average Values

		CORE DATA		JOB MIX TOLERANCE (Class "B" Mix)	
		TOP LAYER	BASE LAYER	TOP LAYER	BASE LAYER
Rice Gravity T 209		2.50 ± .02	2.49 ± .02	-	-
Bulk S.G.		2.19 ± .05	2.28 ± .05	-	-
% Voids In Place		12.2 ± 2.4	8.3 ± 2.5	-	-
Modulus x 10 ³ psi		262 ± 38	356 ± 71	-	-
GRADATION LIMITS, % PASSING	3/4	96.3-99.9	95.4-99.1	92 - 100	
	1/2	84.0-92.7	82.7-91.0	81 - 93	
	1/4	57.5-71.5	58.7-67.7	54 - 66	
	10	26.7-33.2	29.1-33.9	26 - 34	
	40	11.9-16.0	14.2-15.7	8 - 16	
	200	5.9- 6-8	6.8- 7.4	3 - 7	
% A.C.		5.4 ± .4	5.8 ± .5	4.6-5.6	5.2-6.2
RECOVERED ASPHALT PROPERTIES AASHTO-T-170	Penetration At 70°F(21°C) (cm/100)	28	29	---	
	Kinematic Viscosity At 275°F(135°C) (cs.)	397	366	---	
	Absolute Viscosity At 140°F(60°C) (Poise)	4409	3819	---	

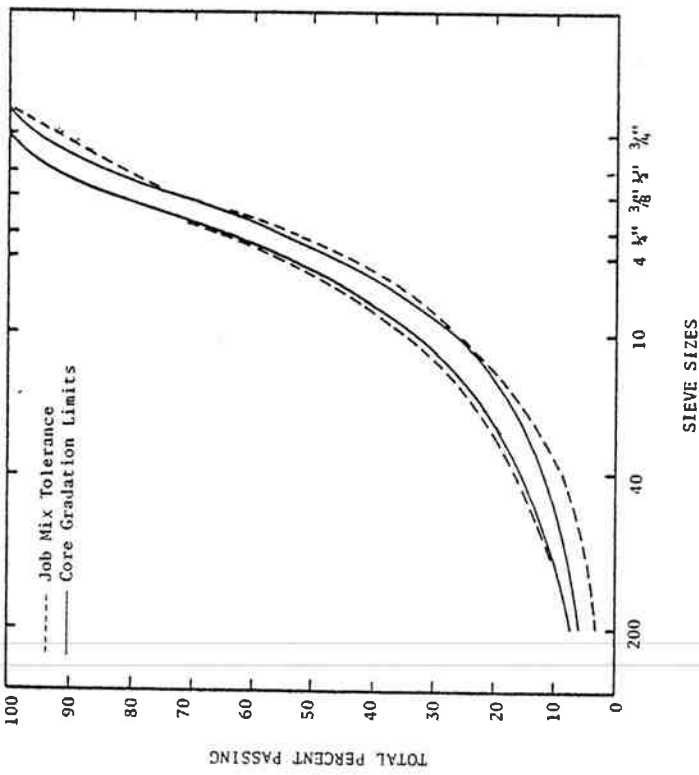

Figure 4. Core Gradation, Top Layer

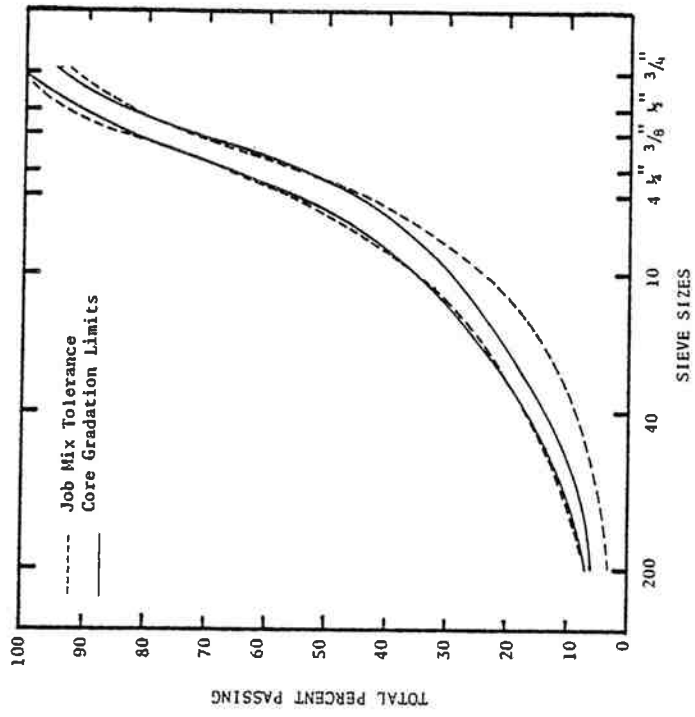

Figure 5. Core Gradation, Base Layer

4.0 TEST RESULTS - OSU

The purpose of the tests performed at Oregon State University was to determine the fatigue life and permanent deformation characteristics of the asphalt mix. All tests were performed over the selected range of variables on standard laboratory samples using the repeated load indirect tensile test. The samples were prepared according to the Oregon State Highway Division standard procedure (2). The materials used are the same as used for the mix design reported in Section 3.0.

Test Program

A minimum of 16 samples were prepared for each condition. Eight samples are tested as compacted, and eight samples are tested after conditioning.* Table 9 gives the flow chart for the test program followed. The principal variables studied included:

- (1) Mix level of compaction: 100% - 97% - 93% - 90%
- (2) Percent passing No. 200 sieve: 2% -6% - 10%
- (3) Percent asphalt content: 4.5% - 5.5% - 6.5%

Each of the above variables was studied relative to a standard mix, consisting of 6% passing No. 200 sieve and 5.5% asphalt content. When studying the influence of the mix density, the standard mix was compacted at 97%, while a 93% compaction standard mix was selected to study the influence of the amount of fines, asphalt content and aggregate quality. Detail of the combination of variables used in this analysis are shown in Table 10.

*The sample conditioning procedure followed was based on the moisture damage test defined by Lotman (3). The following are the main steps:

1. Determine the resilient modulus of the as-compacted samples, after overnight cure. Mark along which samples axis the modulus was measured.
2. Vacuum saturating the samples for two hours.
3. Place the saturated samples in a freezer at -18°C for 15 hours.
4. Place the frozen, saturated specimen in a warm water bath for 24 hours.
5. Place the specimen in a water bath at room temperature for three hours.
6. Run the mechanical property tests, along the same sample axis as the as-compacted modulus was measured (Step 1).

Test Equipment

Figure 6 shows the testing equipment used to determine the resilient modulus, fatigue life and permanent deformation characteristics of the specimens.

Table 9. Test Program - OSU

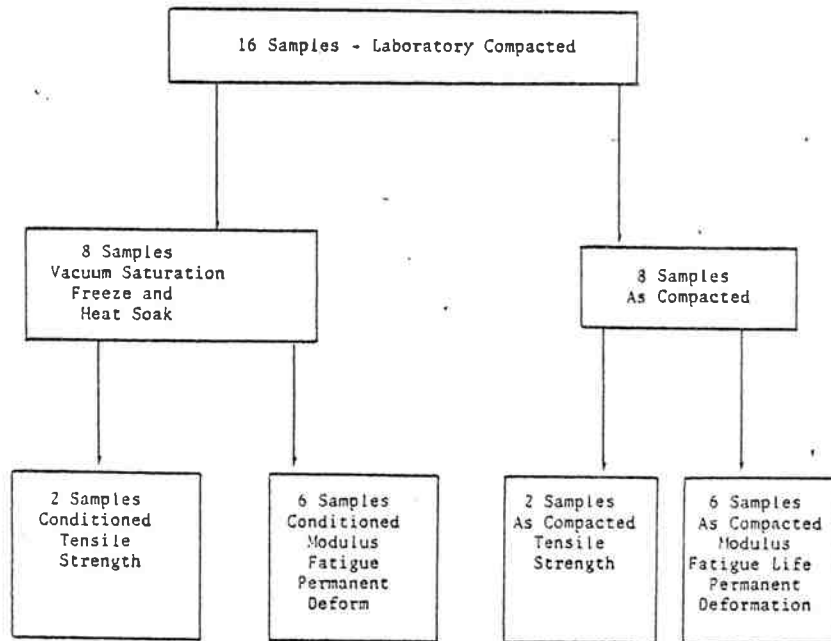

Table 10. Range of Mix Variables Considered in This Study -
(Crossed Boxes)
Warren-Scuppoose

Level of Compaction	2% Passing No. 200			6% Passing No. 200			10% Passing No. 200		
	Asphalt Content			Asphalt Content			Asphalt Content		
	4.5	5.5	6.5	4.5	5.5	6.5	4.5	5.5	6.5
2nd Compaction					X				
1st Compaction					X				
95 Blows at 100 psi 500 psi Leveling Load	X		X	X	X	X	X		X
30 Blows at 100 psi 300 psi Leveling Load					X				

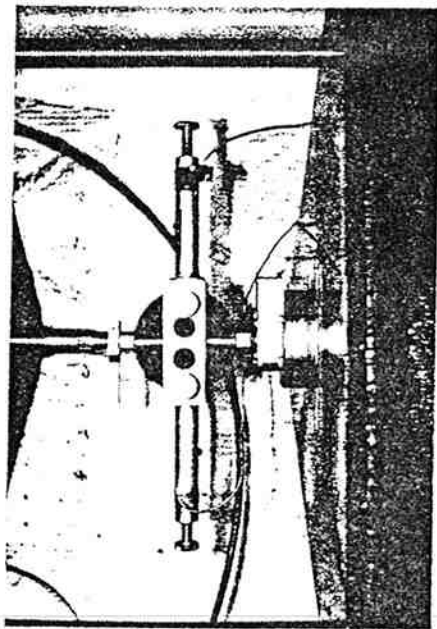

Figure 6. Diametral Test Apparatus.

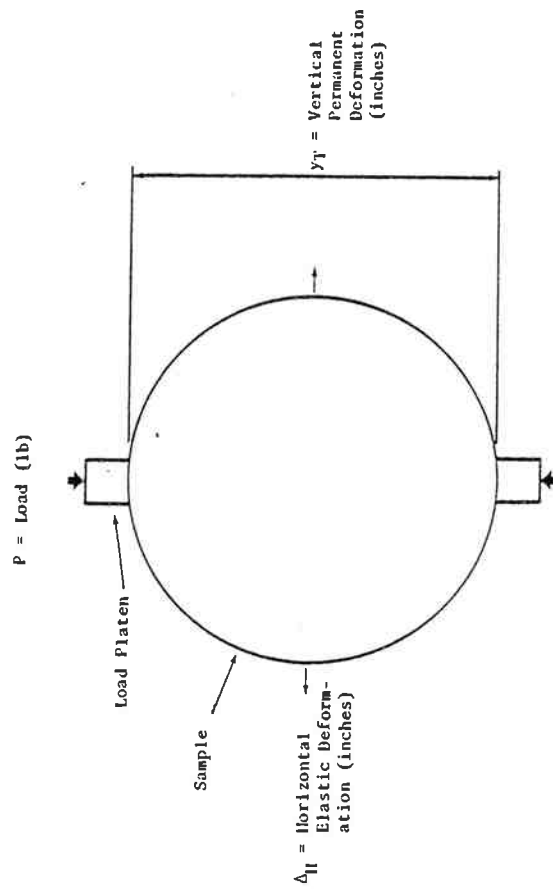

Figure 7. Diametral Test • Variables Recorded

Testing conditions were kept constant, and are summarized as follows:

- (1) A static load of 10 lbs was applied to hold the sample in place.
- (2) The dynamic load duration was fixed at 0.1 seconds and the load frequency at 60 cycles per minute.
- (3) Test temperature was defined as the average sample temperature during testing (normally $22^{\circ}\text{C} \pm 2^{\circ}\text{C}$).
- (4) Load platens are 1/2" (1.3 cm) wide.

Test Procedure and Calculations

All tests were run for mix tensile strain ranging between 50 and 150 microstrain. The parameters recorded during the dynamic diametral test are the maximum load applied, the sample horizontal elastic deformation and the sample vertical permanent deformation (Figure 7).

Dynamic diametral tests were run using the following procedure:

- (1) Place the sample in the dynamic diametral test apparatus.
- (2) Apply approximately 100 load applications until the permanent deformation recorded is negligible compared to the sample elastic response.
- (3) Adjust the dynamic load to achieve the desired initial mix tensile strain.
- (4) Maintain the control set at the load level required and start the fatigue life tests (also monitor permanent deformation).
- (5) Record the number of repetitions to failure.

The maximum load applied and the horizontal elastic tensile deformation were recorded to determine the modulus using the following equation (4):

$$M_R = \frac{P}{\Delta H \times h} (.2692 + .9974\nu) \quad (1)$$

where ΔH = horizontal elastic tensile deformation, inches
 P = dynamic load, pounds
 h = sample thickness, inches
 ν = Poisson's ratio

Poisson's ratio was assumed constant and equal to .35, which simplifies equation (1) to:

$$M_R = \frac{P \times .6183}{\Delta H \times h} \quad (2)$$

Fatigue life is characterized by the number of load applications required to cause failure of the sample. Attempts to relate the number of load applications to the sample state of stress and strain showed that the best correlation exists between the tensile strain and the number of load applications, according to the following model (5,6,7,8):

$$N_f = K \left(\frac{1}{\epsilon_t} \right)^C \quad (3)$$

where: N_f = number of load repetitions to failure
 K, C = regression constants
 ϵ_t = horizontal elastic tensile strain.

The fatigue life of a specific mix is therefore defined by the constants K and C . For each set of mix variables, six samples were tested at different values of the initial tensile strain. The number of load repetitions to failure was then measured and recorded. The constants K and C are determined using linear regression by the method of least squares. The tensile strain ϵ_t is calculated from the following equation (3):

$$\epsilon_t = \Delta H \left(\frac{.03896 + .1185\nu}{.0673 + .2494\nu} \right) \quad (4)$$

where ϵ_t = horizontal elastic tensile strain
 ΔH = horizontal elastic tensile deformation, inches
 ν = Poisson's ratio

Assuming the Poisson's ratio is constant and equal to .35, equation (4) becomes:

$$\epsilon_t = \Delta H \times .5203 \quad (5)$$

The number of load repetitions to fatigue failure was defined as the number of repetitions required to get a vertical crack approximately 1/4" (.64 cm) wide in the samples. To stop the test at the specified level of sample deformation, a thin aluminum strip was attached to the sides of the samples, along a plane perpendicular to the plane formed by the load platen (see Figure 8). The aluminum strip is connected to a normally closed relay, which controls the dynamic load system. As the sample deforms, the aluminum strip is stressed. When the sample deformation exceeds a certain level, the aluminum strip breaks and opens the relay, which shuts off the test. Proper calibration of the length

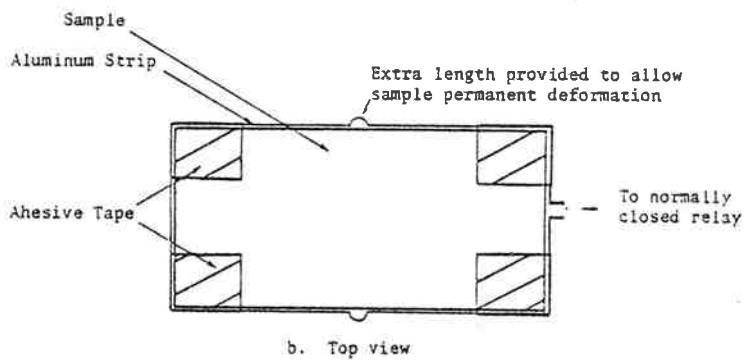
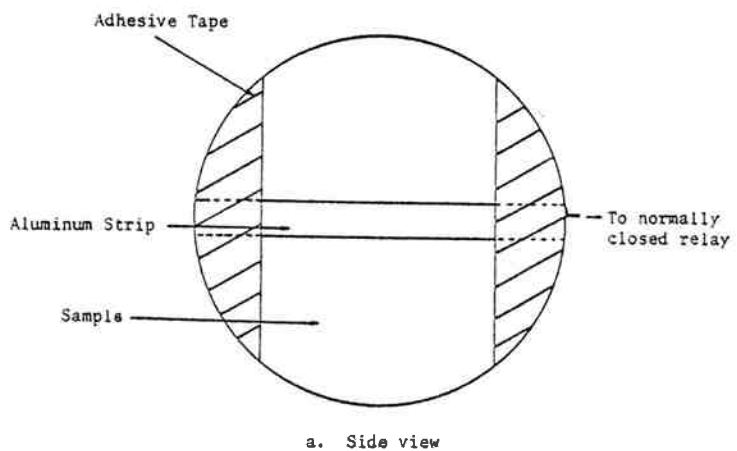

Figure 3. Schematic View of the Automatic Shut-Off Device for Fatigue Testing

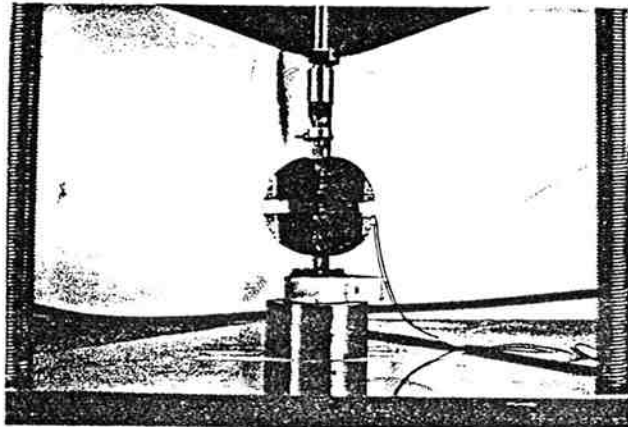

Figure 9. Sample at End of Fatigue Test.

of the aluminum strip will cause the test to stop for a specific sample crack width (Figure 9).

The vertical permanent strain is also recorded during the fatigue test as a function of the number of load repetitions. The permanent deformation strain is given by (3):

$$\epsilon_C = \mu_t \left[\frac{-.03896v - .1185}{.0156v - .8954} \right] \quad (6)$$

where ϵ_C = vertical permanent compressive strain
 μ_t = vertical permanent compressive deformation, inches
 v = Poisson's ratio

If the Poisson's ratio is assumed constant and equal to .35, equation (6) becomes:

$$\epsilon_C = \mu_t \times .1485 \quad (7)$$

Resilient modulus, fatigue and permanent deformation models and tensile strength values have been determined for each set of variables considered in this study. The significance of these results and their correlation with other mix properties are developed later in this chapter.

Resilient Modulus Data

The resilient modulus data of the as-compacted samples are presented in Table 11, along with the mix Bulk Specific gravity and percent voids. The mix Bulk Specific gravity seems to be a predominant factor affecting the mix resilient modulus. This appears in Figure 10, where the mix resilient modulus has been plotted versus the mix Bulk Specific gravity. The resilient modulus data have been divided into three groups, corresponding to the three asphalt content considered in this study: 4.5, 5.5 and 6.5 percent asphalt content. As the mix Bulk Specific gravity increases, the mix resilient modulus increases, at a rate function of the asphalt content. For a constant value of the Bulk Specific Gravity, the lower the asphalt content, the higher the resilient modulus.

Influence of asphalt content and amount of fines is more clearly shown in Figure 11, where the as-compacted mix resilient modulus are plotted versus the percent passing No. 200. This figure shows again that mixes composed of 4.5% asphalt have higher modulus than mixes with 5.5 or 6.5% asphalt when the amount of fine is at the design optimum. However, decreasing the asphalt and

Table 11a. Resilient Modulus Data, as Compacted Samples
 -Resilient Modulus, psi
 -Percent Voids
 -Bulk Specific Gravity

LEVEL OF COMPACTION	2% PASSING NO. 200			6% PASSING NO. 200			10% PASSING NO. 200		
	ASPHALT CONTENT			ASPHALT CONTENT			ASPHALT CONTENT		
	4.5	5.5	6.5	4.5	5.5	6.5	4.5	5.5	6.5
2nd Compaction					1,082,000 1.6 2.45				
1st Compaction					887,000 4.4 2.38				
95 Blows At 100 psi 500 psi Leveling Load	373,000 12.3 2.21		418,000 8.9 2.24	909,000 10.5 2.27	736,000 8.0 2.29	651,000 6.1 2.30	959,000 8.7 2.30		690,000 5.2 2.39
30 Blows At 100 psi 500 psi Leveling Load					265,000 11.6 2.20				

Table 11b. Resilient Modulus Data, Conditioned Samples
 -Resilient Modulus
 -% Retained Stiffness $\left(\frac{\text{Conditioned Modulus}}{\text{As Compacted Modulus}} \times 100 \right)$

LEVEL OF COMPACTION	2% PASSING NO. 200			6% PASSING NO. 200			10% PASSING NO. 200		
	ASPHALT CONTENT			ASPHALT CONTENT			ASPHALT CONTENT		
	4.5	5.5	6.5	4.5	5.5	6.5	4.5	5.5	6.5
2nd Compaction					1,008,000 93%				
1st Compaction					688,000 77%				
95 Blows At 100 psi 500 psi Leveling Load	395,000 106%		300,000 72%	659,000 72%	610,000 83%	527,000 83%	684,000 71%		653,000 95%
30 Blows At 100 psi 500 psi Leveling Load					312,000 118%				

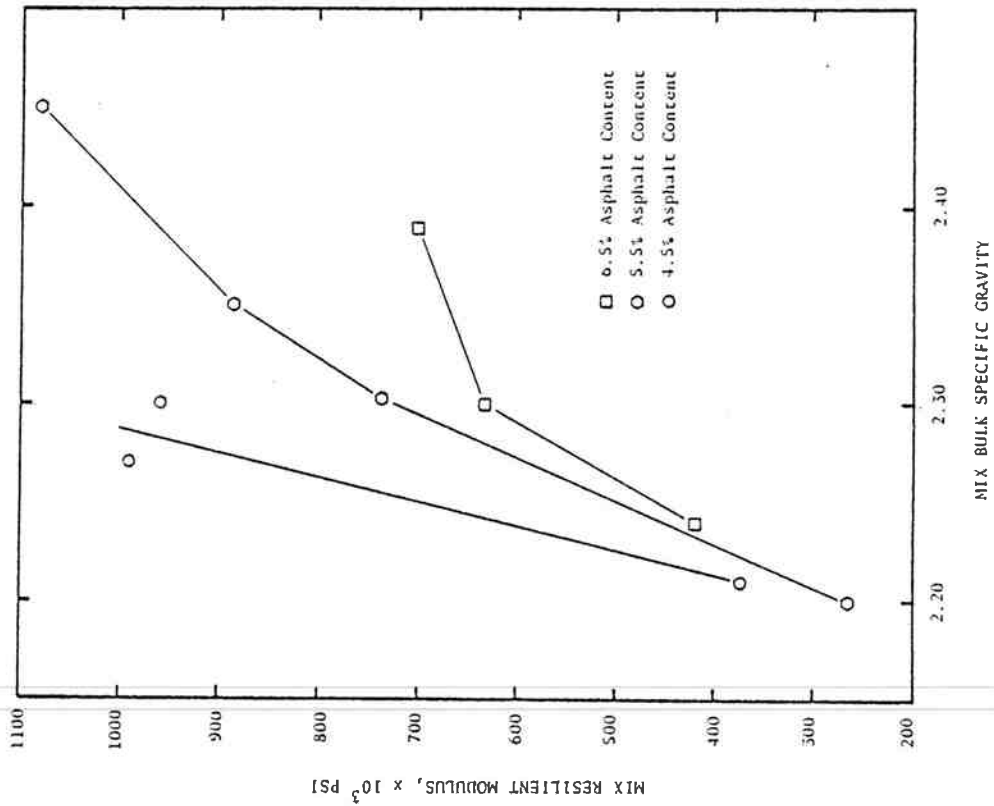

Figure 10. Influence of Bulk Specific Gravity on Resilient Modulus, As Compacted Samples.

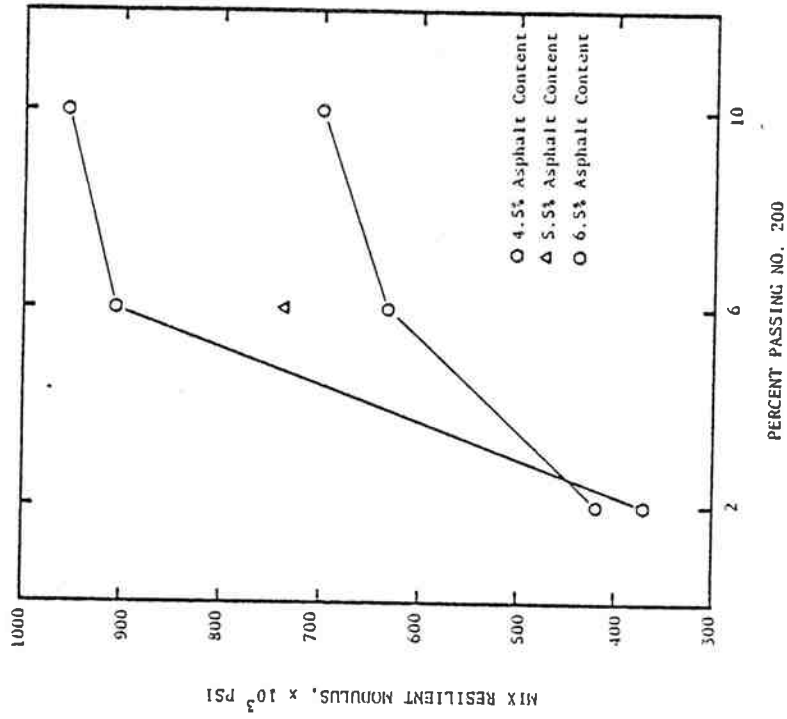

Figure 11. Influence of Amount of Fines on Resilient Modulus - As Compacted Samples.

finer content causes a substantial decrease in the mix stiffness. Similar trends can be observed with the conditioned samples.

Moduli values of conditioned samples are presented in Table 11 together with their percentage of retained stiffness (compared with the mix modulus measured before sample conditioning). These data indicate wide variations in the percentage of retained stiffness, with no clear correlation with the amount of fines and asphalt or with the Mix Bulk Specific Gravity. The relationship between conditioned modulus and the mix Bulk Specific Gravity (Figure 12) shows trends similar to the as-compacted data. The three groups of mix resilient modulus (4.5, 5.5 and 6.5% asphalt) give three sets of curves almost parallel. As for the as-compacted data, it appears from this figure that the mix resilient modulus decreases when the asphalt content increases.

Figure 13 shows the relationship between the mix resilient modulus and the percent passing No. 200. Results are very similar to the results found with the as-compacted data, and indicate an increase in resilient modulus when the percent passing No. 200 is increased. Increasing the asphalt content also decreases the resilient modulus.

In summary, the mix resilient modulus is primarily affected by the mix Bulk Specific Gravity. The mix resilient modulus increases when:

- 1) the percent passing No. 200 increases
- 2) the amount of asphalt decreases.

Fatigue Data

The fatigue life of asphalt mixes is a function of initial tensile strain and follows the equation:

$$N_f = K(\epsilon_t)^m \quad (8)$$

where N_f = number of load repetitions to failure
 ϵ_t = initial tensile strain
 K, m = regression constants

Both K and m are affected by the mix variables. For each set of mix conditions, six samples were tested at the following initial tensile strains: 50, 65, 85, 100, 125 and 150 microstrains. The coefficients K and m were then determined by linear regression analysis. Table 12 shows the as-compacted K and m values found for different percentages of asphalt, amount of fines and level of compaction.

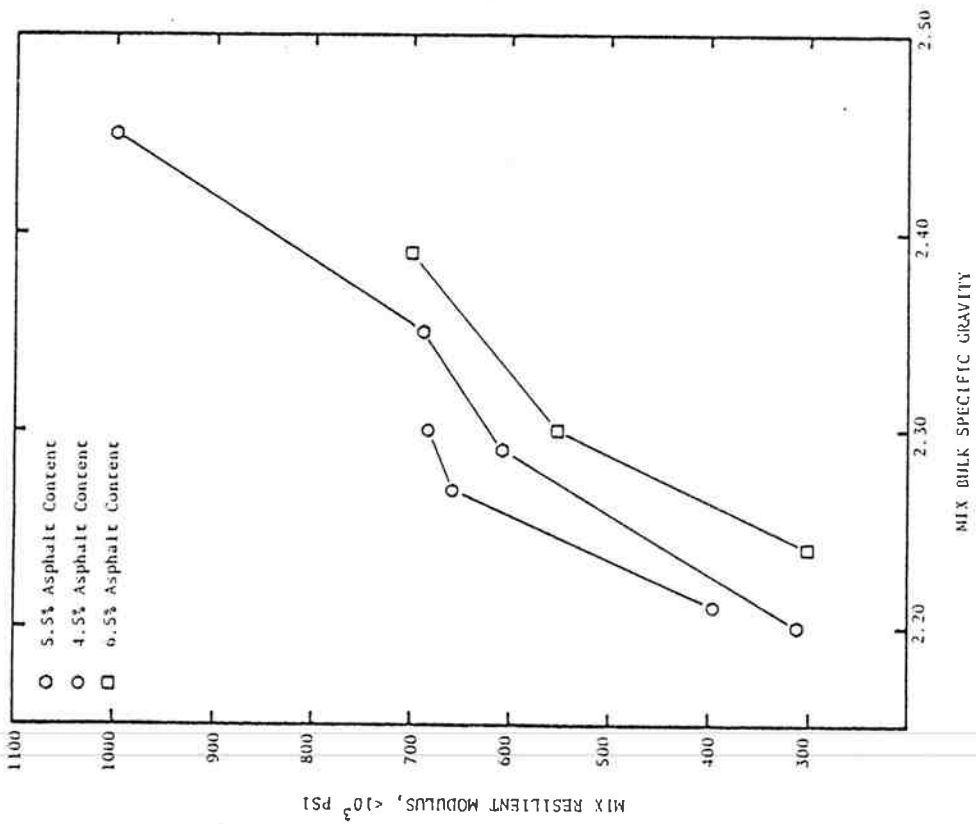

Figure 12. Influence of Bulk Specific Gravity on Resilient Modulus. Conditioned Samples.

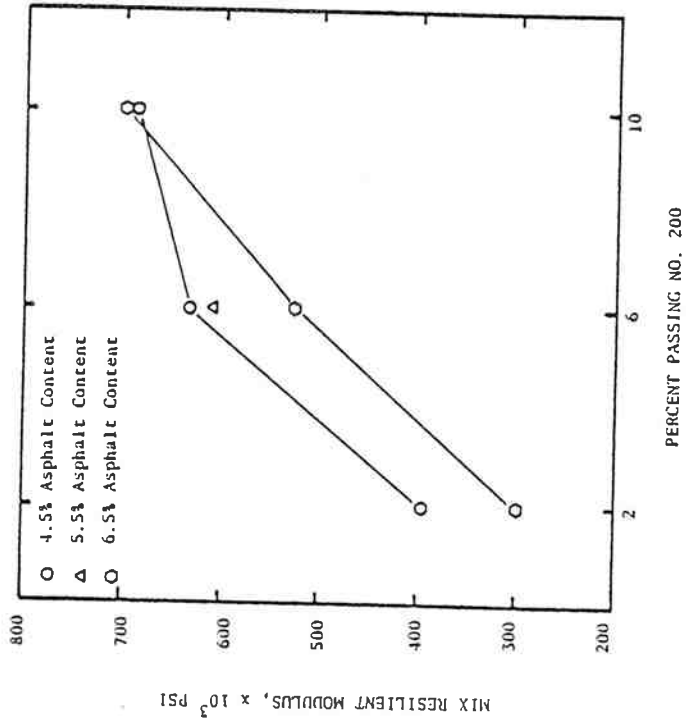

Figure 13. Influence of Amount of Fines on Resilient Modulus - Conditioned Samples.

Table 12a. Original Fatigue Data - As Compacted Data

$$(N_F = k(\epsilon_T)^m)^*$$

LEVEL OF COMPACTION	2% PASSING NO. 200			6% PASSING NO. 200			10% PASSING NO. 200		
	ASPHALT CONTENT			ASPHALT CONTENT			ASPHALT CONTENT		
	4.5	5.5	6.5	4.5	5.5	6.5	4.5	5.5	6.5
2nd Compaction					$k=6.76 \times 10^{-9}$ $m=-3.09$				
1st Compaction					$k=1.46 \times 10^{-4}$ $m=-2.03$				
95 Blows At 100 psi 500 psi Leveling Load	$k=1.90 \times 10^{-1}$ $m=-1.12$		$k=9.30 \times 10^{-5}$ $m=-1.48$	$k=1.66 \times 10^{-5}$ $m=-2.16$	$k=2.10 \times 10^{-6}$ $m=-2.41$	$k=1.00 \times 10^{-6}$ $m=-2.53$	$k=6.29 \times 10^{-9}$ $m=-2.96$		$k=2.87 \times 10^{-8}$ $m=-3.05$
30 Blows At 100 psi 300 psi Leveling Load					$k=7.65 \times 10^{-2}$ $m=-1.26$				

* N_F : Number of load repetitions to failure.

ϵ_T : Mix elastic tensile strain.

k,m: Regression constants.

Table 12b. Original Fatigue Data - Conditioned Samples

$$(N_F = k(\epsilon_T)^m)^*$$

LEVEL OF COMPACTION	2% PASSING NO. 200			6% PASSING NO. 200			10% PASSING NO. 200		
	ASPHALT CONTENT			ASPHALT CONTENT			ASPHALT CONTENT		
	4.5	5.5	6.5	4.5	5.5	6.5	4.5	5.5	6.5
2nd Compaction					$k=2.61 \times 10^{-1}$ $m=-3.69$				
1st Compaction					$k=1.70 \times 10^{-6}$ $m=-2.50$				
95 Blows At 100 psi 500 psi Leveling Load	$k=2.13 \times 10^{-1}$ $m=-1.15$		$k=1.69 \times 10^{-5}$ $m=-1.69$	$k=1.16 \times 10^{-4}$ $m=-2.00$	$k=2.91 \times 10^{-5}$ $m=-1.67$	$k=3.54 \times 10^{-5}$ $m=-2.12$	$k=7.09 \times 10^{-8}$ $m=-2.80$		$k=5.60 \times 10^{-8}$ $m=-2.95$
30 Blows At 100 psi 300 psi Leveling Load					$k=5.51 \times 10^{-3}$ $m=-1.67$				

* N_F : Number of load repetitions to failure.

ϵ_T : Mix elastic tensile strain.

k,m: Regression constants.

From this data, the relationship between m and $\log(K)$ was plotted in Figure 14. The relationship m versus $\ln(K)$ follows the equation:

$$m = A_1 \ln(K) + A_0 \quad (9)$$

Linear regression run on the as-compacted data gave:

$$\begin{aligned} A_1 &= .113 \\ A_0 &= -.963 \\ \text{Coefficient of correlation: } r^2 &= .991 \end{aligned}$$

It can be deduced from this relationship between m and $\ln(K)$ that the fatigue curves, expressed in number of load repetitions versus mix tensile strain, should intercept at a common point, called focus point (11, 12, 13). The coordinates of this focus point (ϵ_0, N_0) can be deduced from equation (9) and (8):

$$m = A_0 + A_1 \ln(K) \quad (9)$$

$$N_F = K(\epsilon)^m \Leftrightarrow \ln(N_F) = \ln(K) + m \ln(\epsilon) \quad (8)$$

Equation (8) is also true at the focus point:

$$\begin{aligned} \ln(N_0) &= \ln(K) + m \ln(\epsilon_0) \\ \Rightarrow m &= \frac{\ln(N_0)}{\ln(\epsilon_0)} - \frac{1}{\ln(\epsilon_0)} \times \ln(K) \quad (10) \end{aligned}$$

Comparison between equation (10) and equation (9) gives:

$$A_0 = \frac{\ln(N_0)}{\ln(\epsilon_0)} \quad \text{and} \quad A_1 = \frac{-1}{\ln(\epsilon_0)}$$

Coordinates of the as-compacted samples focus point gave:

$$\begin{aligned} \epsilon_0 &= 138.7 \times 10^{-6} \\ N_0 &= 5,183 \end{aligned}$$

Knowing the coordinates of the focus point, linear regression analysis were rerun for each set of samples, and fitted through the focus point.

Table 13a gives the corrected K and m values (noted k' and m').

The same approach was followed for the conditioned test results. Table 12b gives the original K and m values computed from the test results. The relationship found between K and m is:

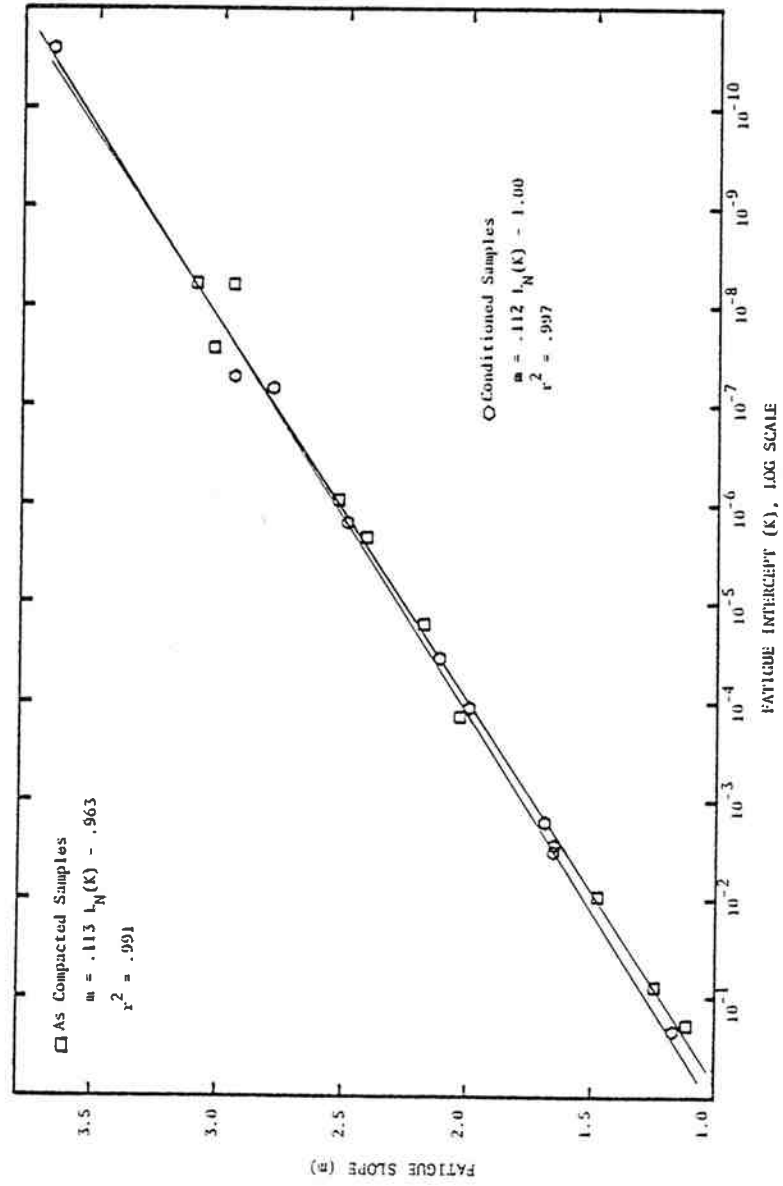

Figure 14. Relationship Between K and m.

Table 13a. Corrected Fatigue Data - As Compacted Samples

$$(N_F = k'(\epsilon_T)^{m'})^*$$

LEVEL OF COMPACTION	2% PASSING NO. 200			6% PASSING NO. 200			10% PASSING NO. 200		
	ASPHALT CONTENT			ASPHALT CONTENT			ASPHALT CONTENT		
	4.5	5.5	6.5	4.5	5.5	6.5	4.5	5.5	6.5
2nd Compaction					$k'=8.84 \times 10^{-9}$ $m'=-3.05$				
1st Compaction					$k'=3.25 \times 10^{-8}$ $m'=-2.90$				
95 Blows At 100 psi 500 psi Leveling Load	$k'=4.77$ $m'=-.79$		$k'=2.83 \times 10^{-2}$ $m'=-1.36$	$k'=3.73 \times 10^{-2}$ $m'=-1.33$	$k'=3.77 \times 10^{-5}$ $m'=-2.11$	$k'=4.25 \times 10^{-7}$ $m'=-2.61$	$k'=2.21 \times 10^{-2}$ $m'=-1.59$		$k'=7.85 \times 10^{-15}$ $m'=-4.62$
30 Blows At 100 psi 300 psi Leveling Load					$k'=2.40 \times 10^{-2}$ $m'=-1.38$				

* N_F : Number of load repetitions to failure.

ϵ_T : Mix elastic tensile strain.

k', m' : Regression constants.

Table 13b. Corrected Fatigue Data - Conditioned Samples

$$(N_F = k'(\epsilon_T)^{m'})^*$$

LEVEL OF COMPACTION	2% PASSING NO. 200			6% PASSING NO. 200			10% PASSING NO. 200		
	ASPHALT CONTENT			ASPHALT CONTENT			ASPHALT CONTENT		
	4.5	5.5	6.5	4.5	5.5	6.5	4.5	5.5	6.5
2nd Compaction					$k'=1.12 \times 10^{-9}$ $m'=-3.30$				
1st Compaction					$k'=3.95 \times 10^{-7}$ $m'=-2.65$				
95 Blows At 100 psi 500 psi Leveling Load	$k'=5.40$ $m'=-.81$		$k'=6.50 \times 10^{-2}$ $m'=-1.31$	$k'=5.18 \times 10^{-4}$ $m'=-1.84$	$k'=4.32 \times 10^{-4}$ $m'=-1.85$	$k'=7.38 \times 10^{-4}$ $m'=-1.81$	$k'=1.32 \times 10^{-5}$ $m'=-2.25$		$k'=1.42 \times 10^{-11}$ $m'=-3.82$
30 Blows At 100 psi 300 psi Leveling Load					$k'=6.49 \times 10^{-5}$ $m'=-2.08$				

* N_F : Number of load repetitions to failure.

ϵ_T : Mix elastic tensile strain.

k', m' : Regression constants.

$$\begin{aligned}
 m &= .112 \ln(K) - 1.00 \\
 r^2 &= .997
 \end{aligned}
 \tag{10}$$

he coordinates of the focus point for the conditioned samples are $\epsilon_o = 129.0 \times 10^{-6}$ microstrain and $N_o = 7,767$ load repetitions. The corrected K' and m' for the conditioned samples are given in Table 13b.

The effect of asphalt content, passing No. 200 and level of compaction on fatigue life can be estimated directly by plotting for each set of conditions, mix tensile strain versus the number of repetitions to failure. The fatigue curves for 5.5% asphalt content and 6% passing the No. 200 sieve are presented in Figure 15a for the as-compacted samples and Figure 15b for the conditioned samples. As-compacted and conditioned results show a substantial decrease in fatigue life when the mix density drops from 97% to 93% and 90%. The influence of asphalt content is illustrated in Figure 16.

The conditioning process has a strong effect on the asphalt-aggregate bond. This is noticeable when comparing Figure 16a (as-compacted data) with Figure 16b (conditioned data). The as-compacted data show a continuous increase in fatigue life when the asphalt content is increased. This is not any more true after conditioning. The results appear less influenced by the asphalt content, and an optimum asphalt content (5.5%) is now noticeable.

The influence of the percent passing No. 200 on the mix fatigue life was studied at 4.5% asphalt content (Figure 17) and 6.5% asphalt content (Figure 18). In all cases, an increase in the amount of fines results in an increased mix fatigue life. At 4.5% asphalt content, the reduction in mix fatigue life is particularly important when the amount of fines is reduced from 6 to 2%. However, the increase in fatigue life resulting from an increase in amount of fines from 6 to 10% is comparatively smaller. When increasing the asphalt content to 6.5%, the fatigue life is increased and the influence of the amount of fines remains very significant. With 6.5% asphalt, the loss in fatigue resulting from a decrease in the amount of fines is less significant than the increase in fatigue life resulting from an increase in the amount of fines. This shows the importance of the asphalt-percent passing No. 200 interaction.

In summary, the mix fatigue life is affected primarily by the mix density. Optimum asphalt content (5.5%) is apparent in the conditioned test results. An increase in percent passing No. 200 result in a longer fatigue life.

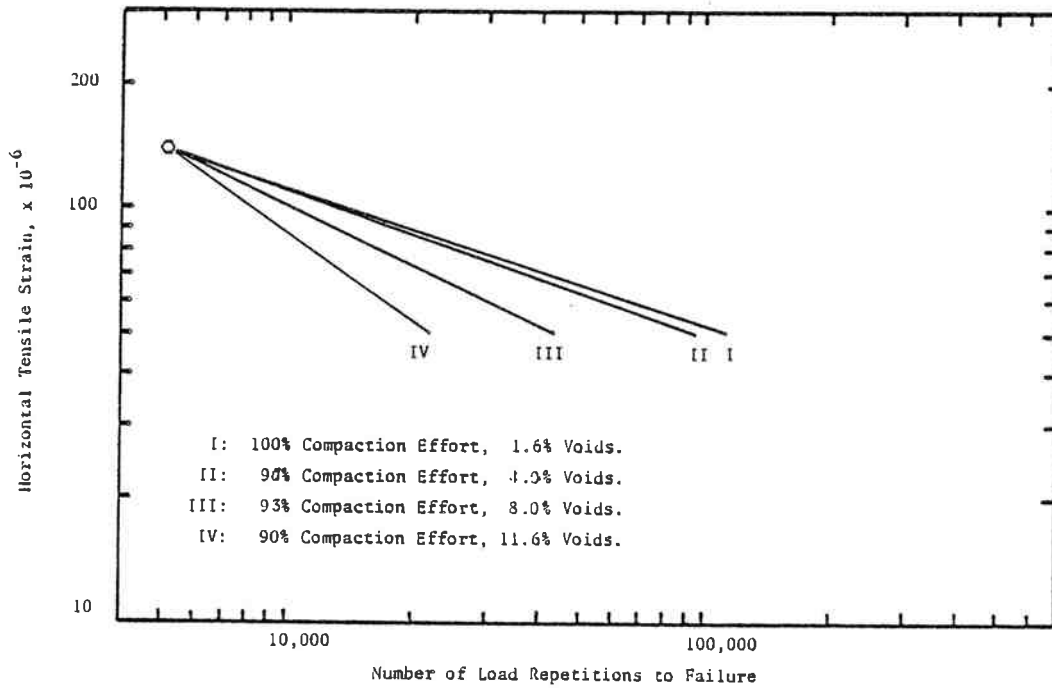

Figure 15a. Influence of Mix Density on Fatigue Life, as Compacted Samples.
6% Passing No. 200 - 25% Passing No. 10 - 5.5% Asphalt.

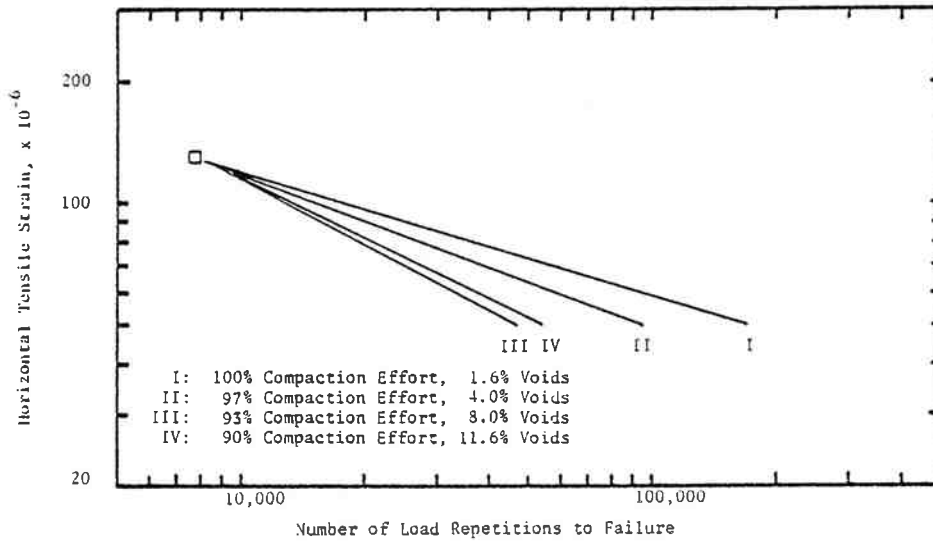

Figure 15b. Influence of Mix Density on Fatigue Life, Conditioned Samples.
6% Passing No. 200 - 25% Passing No. 10 - 5.5% Asphalt.

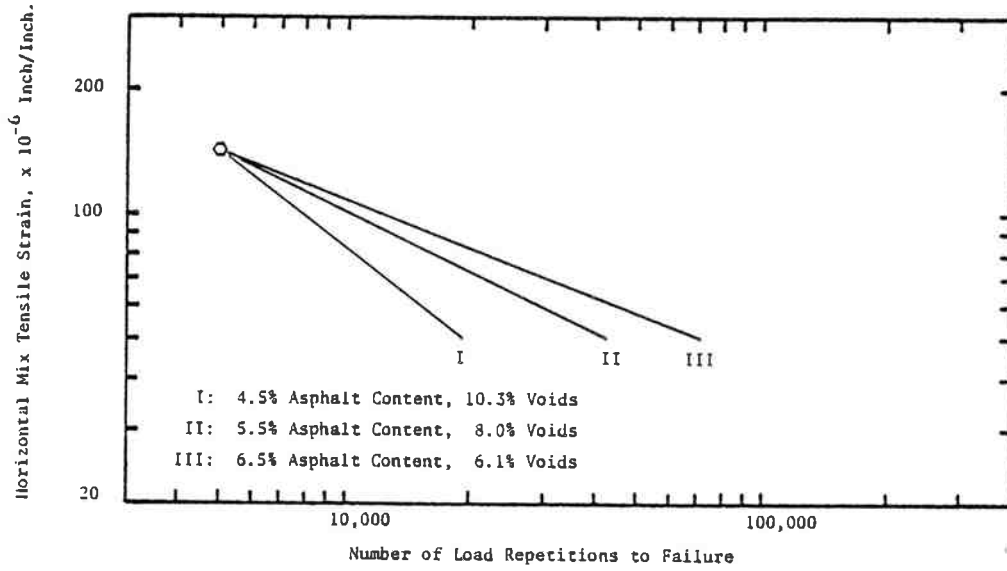

Figure 16a. Influence of Asphalt Content on Fatigue Life, as Compacted Samples.
6% Passing No. 200 - 25% Passing No. 10 - 93% Compaction

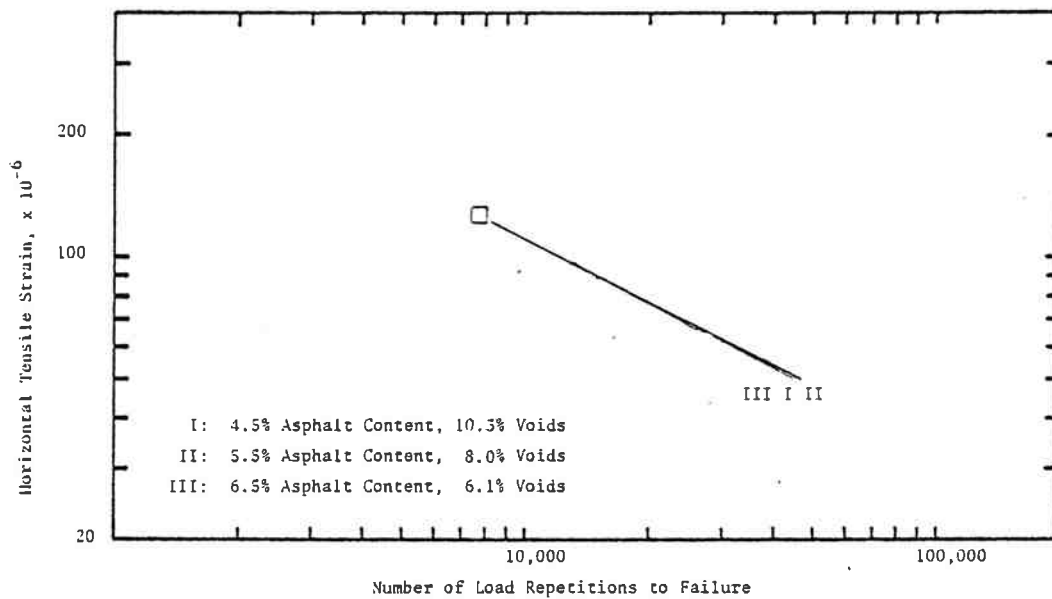

Figure 16b. Influence of Asphalt Content on Fatigue Life, Conditioned Samples
6% Passing No. 200 - 25% Passing No. 10 - 93% Compaction

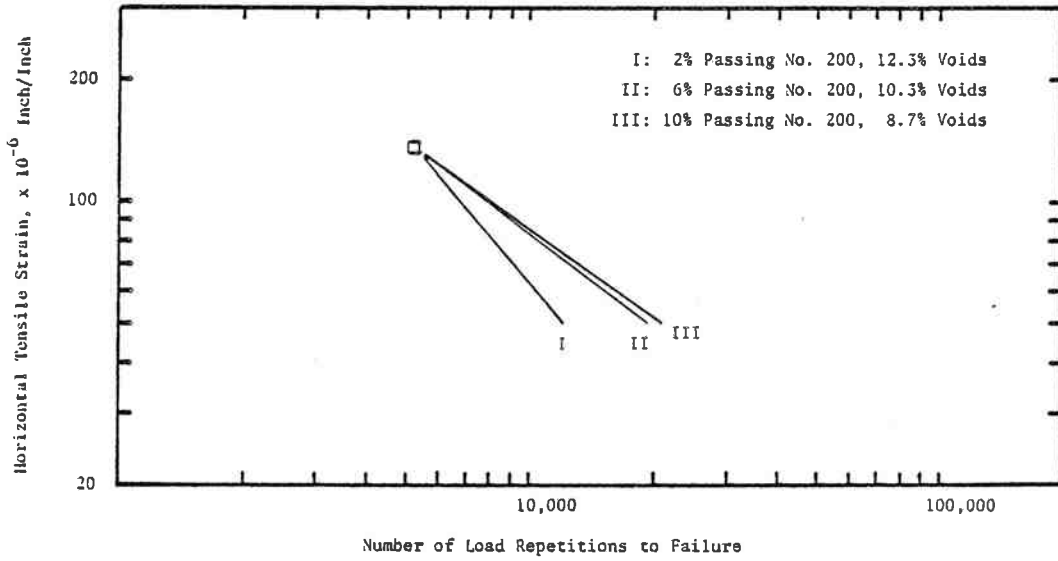

Figure 17a. Influence of Passing No. 200 on Fatigue Life, as Compacted Samples.
 4.5% Asphalt Content - 93% Compaction.

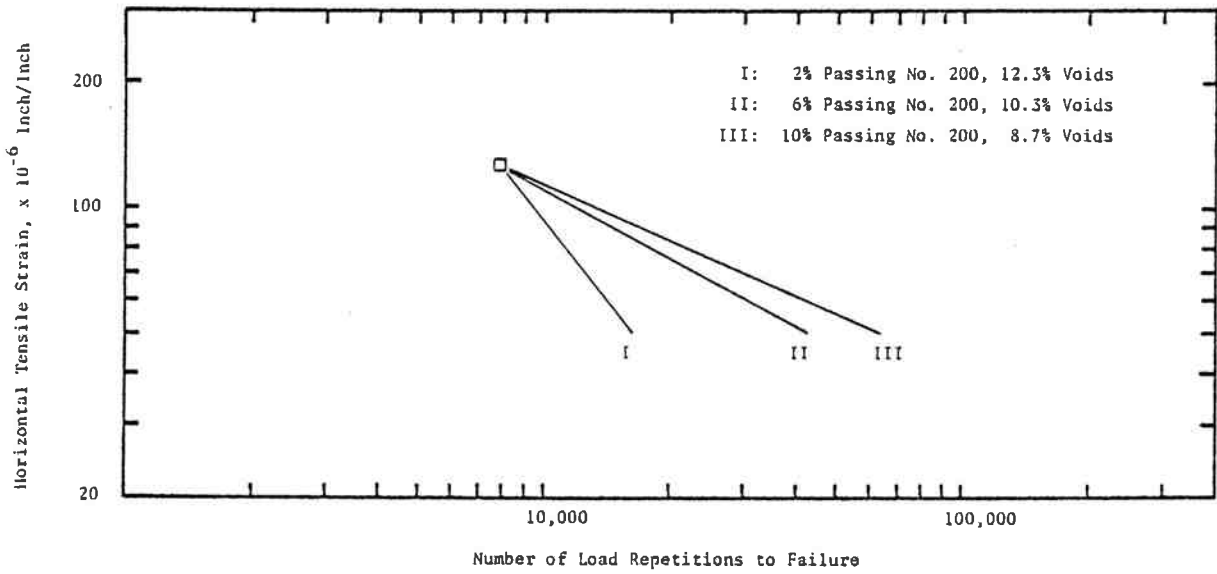

Figure 17b. Influence of Passing No. 200 on Fatigue Life, Conditioned Samples.
 4.5% Asphalt - 93% Compaction.

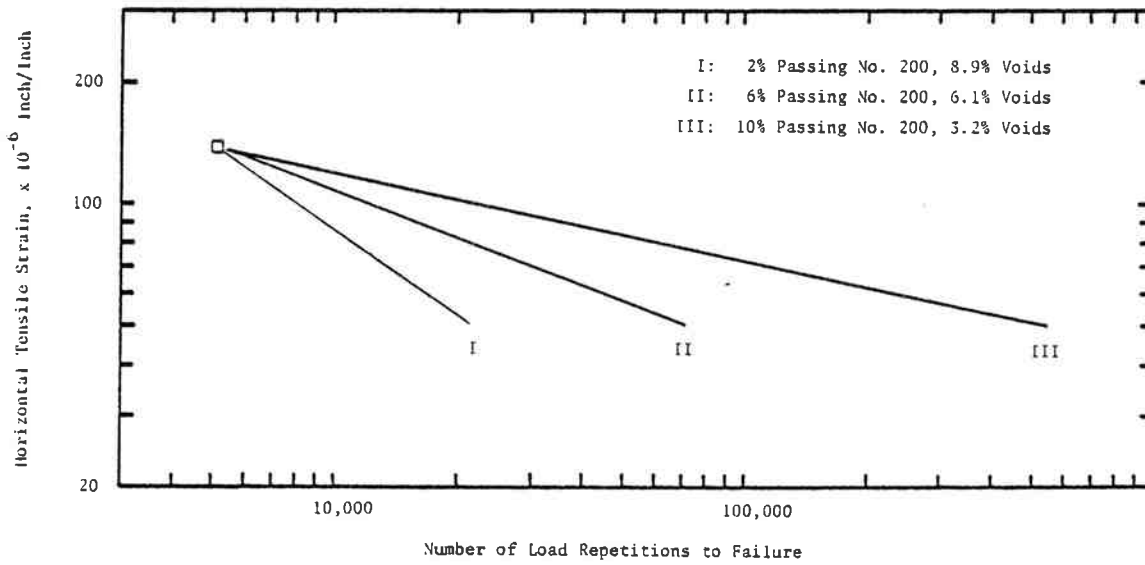

Figure 18a. Influence of Passing No. 200 on Fatigue Life, as Compacted Samples.
 6.5% Asphalt - 93% Compaction.

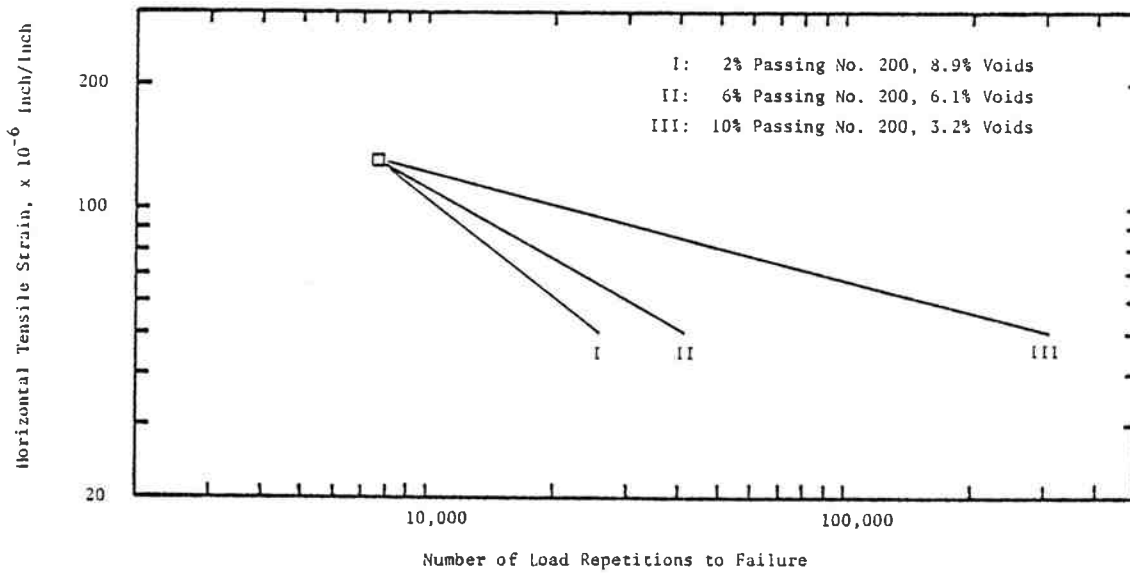

Figure 18b. Influence of Passing No. 200 on Fatigue Life, Conditioned Samples.

6.5% Asphalt - 95% Compaction

Permanent Deformation Data

Vertical compressive permanent deformation was recorded during fatigue testing using a dial gauge. Readings were taken along a logarithmic scale until failure of the sample. The vertical permanent strain was calculated from the vertical permanent deformation (4), according to:

$$\epsilon_c = \mu_t \left[\frac{-.03896v - .1185}{.0156v - .8954} \right] \quad (11)$$

where ϵ_c = compressive permanent strain
 μ_t = total vertical deformation, inches
 v = Poisson's ratio

For a Poisson's ratio of .35, equation (11) becomes:

$$\epsilon_c = \mu_t \times .1485 \quad (12)$$

A typical plot of ϵ_c versus number of load repetitions at different loads is shown in Figure 19 for the mix with 6% passing No. 200, 25% passing No. 10, 5.5% asphalt and 93% relative compaction. Each sample was tested at a different stress level, resulting in a different rate of permanent deformation for each sample. For each test, the relationship between vertical permanent strain and number of load repetitions appears to be linear on log-log scale (10). Using a power curve fit program, it is possible to express the vertical permanent deformation as a function of N:

$$\epsilon_c = I(N)^s \quad (13)$$

where ϵ_c = permanent vertical strain
I, s = regression constants
N = number of load repetitions

Constants I and s, computed from the test results, are presented in Table 12. Non-consistent values (early readings and reading close to sample failure) have not been included in the linear regression.

A recent study showed that the slope s in equation (12) is constant for a specific mix, whereas the intercept I is a function of the mix tensile strain ϵ_t (10). As an example calculation, Table 14 presents the intercept (I) and slope (S) computed for 6 samples tested at different levels of tensile strain. All samples were prepared in the same conditions: 6% passing the No. 200 sieve, 25% passing the No. 10 sieve, 5.5% asphalt content and 93% compaction. A direct plot of the I values shown in Table 14 versus the corresponding tensile strain

Table 14. Permanent Deformation Constants, As Compacted Samples
 6% Passing No. 200 - 25% Passing No. 10
 5.5% Asphalt Content - 93% Compaction

SAMPLE	INITIAL TENSILE STRAIN (INCH/INCH)	PERMANENT DEFORMATION CONSTANTS		
		I	S	r ²
I	155.47x10 ⁻⁶	2.48x10 ⁻⁴	.539	.996
II	125.51x10 ⁻⁶	2.73x10 ⁻⁴	.503	.997
III	103.80x10 ⁻⁶	1.60x10 ⁻⁴	.526	.995
IV	87.06x10 ⁻⁶	2.41x10 ⁻⁴	.536	.993
V	64.67x10 ⁻⁶	2.35x10 ⁻⁴	.481	.993
VI	52.28x10 ⁻⁶	3.42x10 ⁻⁴	.426	.999

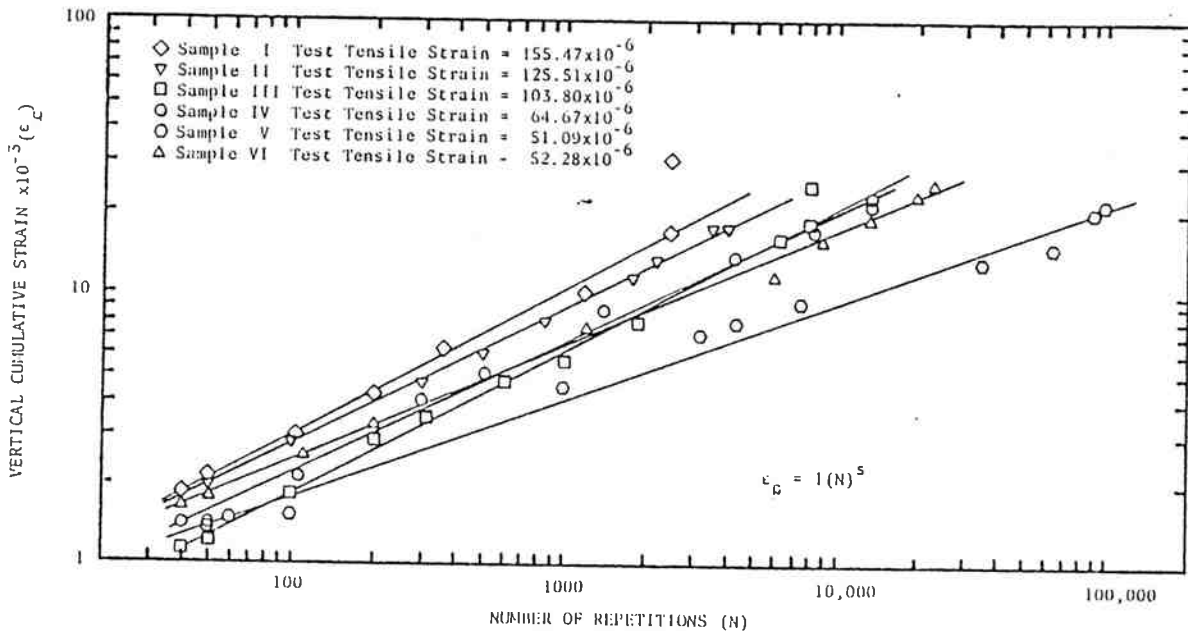

Figure 19. Permanent Deformation Results for Six Samples.

indicates no correlation (Figure 20), which can be explained by the nonuniformity of the computed slope s (Table 14). The linear regressions were therefore rerun using a fixed value for the slope (equal to the average of the slope values shown in Table 12: 0.503). Plotted in Figure 21, the new relationship I versus ϵ_t appears more consistent and linear. Using the data (ϵ_t and I with constant slope s), a linear regression was run, giving the following equation:

$$I = 1.33 (\epsilon_t) + 8.64 \times 10^{-5}$$

$$(r^2 = .701) \tag{14}$$

The samples prepared with 6% passing No. 200, 25% passing No. 10, 5.5% asphalt and compacted at 93% are then characterized by a permanent deformation expressed as follows:

$$\epsilon_c = [1.33 (\epsilon_t) + 8.64 \times 10^{-5}] (N)^{.503} \tag{15}$$

where ϵ_c = compressive permanent strain
 ϵ_t = horizontal tensile strain
 N = number of load repetitions

The same approach was used for all samples. The results are shown in Table 15a for the as-compacted samples and Table 15b for the conditioned samples.

A comparison between results for different mixes was accomplished by setting the mix tensile strain at 100 microstrain and plotting on log-log scale the permanent compressive strain as a function of the number of load repetitions. The results are shown in Table 15c for the as-compacted samples and Table 15d for the conditioned samples. Figure 22a (as-compacted samples) and 22b (conditioned samples) show the influence of mix density on permanent deformation. As expected, low density asphalt concrete mixes are more susceptible to permanent deformation than the dense mixes. Sample conditioning affects especially the low density samples and therefore emphasizes strongly the difference between the dense samples (100% compaction) and the poorly compacted samples (90-93% compaction). The influence of asphalt content on the mix permanent deformation is illustrated in Figures 23a and 23b for samples prepared with 6% passing No. 200. Both as-compacted and conditioned test results indicate an increase in permanent deformation when the percent asphalt content increases. Figures 24a and 24b show the influence of asphalt content when samples are prepared with 2 and 10% passing the No. 200 sieve. The results show that increasing the

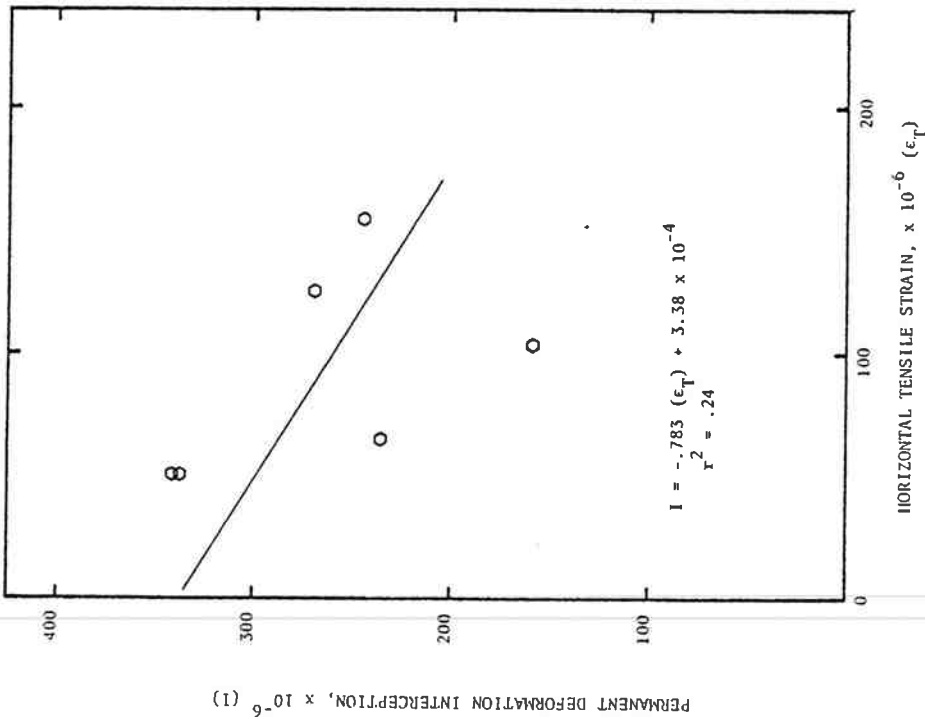

Figure 20. Relationship Between Permanent Deformation Intercept and Horizontal Tensile Strain
 6% Passing No. 200 - 25% Passing No. 10
 5.5% Asphalt Content - 93% Compaction

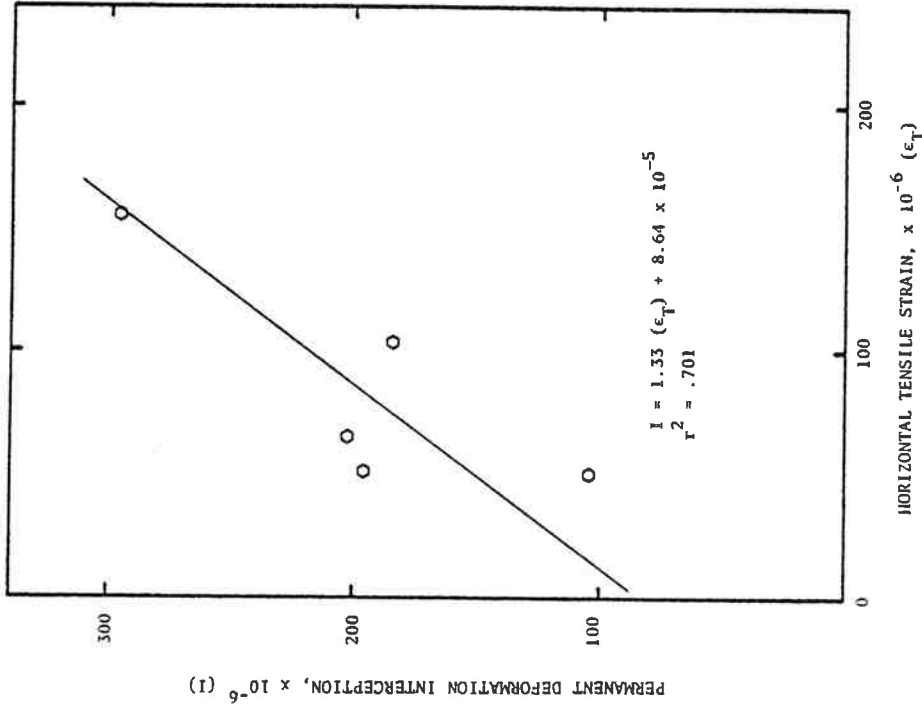

Figure 21. Relationship Between Permanent Deformation Intercept and Horizontal Tensile Strain for a Constant Slope = .503
 6% Passing No. 200 - 25% Passing No. 10
 5.5% Asphalt Content - 93% Compaction.

Table 15a. Permanent Deformation Data, As Compacted Samples
 I: Intercept S: Slope ϵ_T : Mix Tensile Strain

		LEVEL OF COMPACTION			
		SECOND COMPACTION	FIRST COMPACTION	95 Blows at 100 psi 500 psi Leveling Load	50 Blows at 100 psi 300 psi Leveling Load
2% Passing No. 200 Asphalt Content, %	6.5			$I=2.71(\epsilon_T)+8.41 \times 10^{-5}$ $S=.405$	
	5.5				
	4.5			$I=2.39(\epsilon_T)-4.39 \times 10^{-5}$ $S=.525$	
6% Passing No. 200 Asphalt Content, %	6.5			$I=2.04(\epsilon_T)+3.43 \times 10^{-6}$ $S=.521$	
	5.5	$I=1.51(\epsilon_T)+5.99 \times 10^{-5}$ $S=.386$	$I=1.46(\epsilon_T)+2.36 \times 10^{-5}$ $S=.458$	$I=1.33(\epsilon_T)+8.64 \times 10^{-5}$ $S=.503$	$I=1.53(\epsilon_T)+3.29 \times 10^{-4}$ $S=.480$
	4.5			$I=.596(\epsilon_T)+1.51 \times 10^{-4}$ $S=.483$	
10% Passing No. 200 Asphalt Content, %	6.5			$I=.978(\epsilon_T)+3.16 \times 10^{-5}$ $S=.579$	
	5.5				
	4.5			$I=1.26(\epsilon_T)+6.67 \times 10^{-5}$ $S=.542$	

Table 15b. Permanent Deformation Data - Conditioned Samples
 I: Intercept S: Slope ϵ_T : Mix Tensile Strain

		LEVEL OF COMPACTION			
		SECOND COMPACTION	FIRST COMPACTION	95 Blows at 100 psi 500 psi Leveling Load	50 Blows at 100 psi 300 psi Leveling Load
2% Passing No. 200 Asphalt Content	6.5			$I=6.58(\epsilon_T)-9.13 \times 10^{-5}$ $S=.370$	
	5.5				
	4.5			$I=4.05(\epsilon_T)-9.64 \times 10^{-5}$ $S=.453$	
6% Passing No. 200 Asphalt Content	6.5			$I=1.95(\epsilon_T)+9.53 \times 10^{-5}$ $S=.492$	
	5.5	$I=1.90(\epsilon_T)+5.81 \times 10^{-5}$ $S=.332$	$I=2.41(\epsilon_T)+1.01 \times 10^{-5}$ $S=.443$	$I=1.90(\epsilon_T)+1.87 \times 10^{-5}$ $S=.501$	$I=5.63(\epsilon_T)+1.37 \times 10^{-4}$ $S=.442$
	4.5			$I=1.60(\epsilon_T)+1.15 \times 10^{-4}$ $S=.478$	
10% Passing No. 200 Asphalt Content	6.5			$I=2.09(\epsilon_T)+1.14 \times 10^{-4}$ $S=.492$	
	5.5				
	4.5			$I=1.60(\epsilon_T)+6.94 \times 10^{-5}$ $S=.503$	

Table 15c. Permanent Deformation Strain (ϵ_c) for a Mix Tensile Strain (ϵ_t) equal to 100 microstrains. As Compacted Samples.

		LEVEL OF COMPACTION			
		SECOND COMPACTION	FIRST COMPACTION	95 Blows at 100 psi 500 psi Leveling Load	30 Blows at 100 psi 300 psi Leveling Load
10% Passing No. 200 Asphalt Content	6.5			$\epsilon_c = 3.55 \times 10^{-4} (N) \cdot 405$	
	5.5				
	4.5			$\epsilon_c = 1.95 \times 10^{-4} (N) \cdot 525$	
6% Passing No. 200 Asphalt Content	6.5			$\epsilon_c = 2.07 \times 10^{-4} (N) \cdot 521$	
	5.5	$\epsilon_c = 2.11 \times 10^{-4} (N) \cdot 386$	$\epsilon_c = 1.70 \times 10^{-4} (N) \cdot 458$	$\epsilon_c = 2.19 \times 10^{-4} (N) \cdot 503$	$\epsilon_c = 4.82 \times 10^{-4} (N) \cdot 480$
	4.5			$\epsilon_c = 1.91 \times 10^{-4} (N) \cdot 483$	
2% Passing No. 200 Asphalt Content	6.5			$\epsilon_c = 1.29 \times 10^{-4} (N) \cdot 579$	
	5.5				
	4.5			$\epsilon_c = 1.93 \times 10^{-4} (N) \cdot 542$	

Table 15d. Permanent Deformation Strain (ϵ_c) for a Mix Tensile Strain (ϵ_t) Equal to 100 microstrain. Conditioned Samples.

		LEVEL OF COMPACTION			
		SECOND COMPACTION	FIRST COMPACTION	95 Blows at 100 psi 500 psi Leveling Load	30 Blows at 100 psi 300 psi Leveling Load
10% Passing No. 200 Asphalt Content	6.5			$\epsilon_c = 5.67 \times 10^{-4} (N)$	
	5.5				
	4.5			$\epsilon_c = 3.09 \times 10^{-4} (N) \cdot 453$	
6% Passing No. 200 Asphalt Content	6.5			$\epsilon_c = 2.90 \times 10^{-4} (N) \cdot 492$	
	5.5	$\epsilon_c = 2.48 \times 10^{-4} (N) \cdot 532$	$\epsilon_c = 2.51 \times 10^{-4} (N) \cdot 443$	$\epsilon_c = 2.09 \times 10^{-4} (N) \cdot 501$	$\epsilon_c = 7.00 \times 10^{-4} (N) \cdot 442$
	4.5			$\epsilon_c = 2.73 \times 10^{-4} (N) \cdot 478$	
2% Passing No. 200 Asphalt Content	6.5			$\epsilon_c = 3.23 \times 10^{-4} (N) \cdot 492$	
	5.5				
	4.5			$\epsilon_c = 2.29 \times 10^{-4} (N) \cdot 503$	

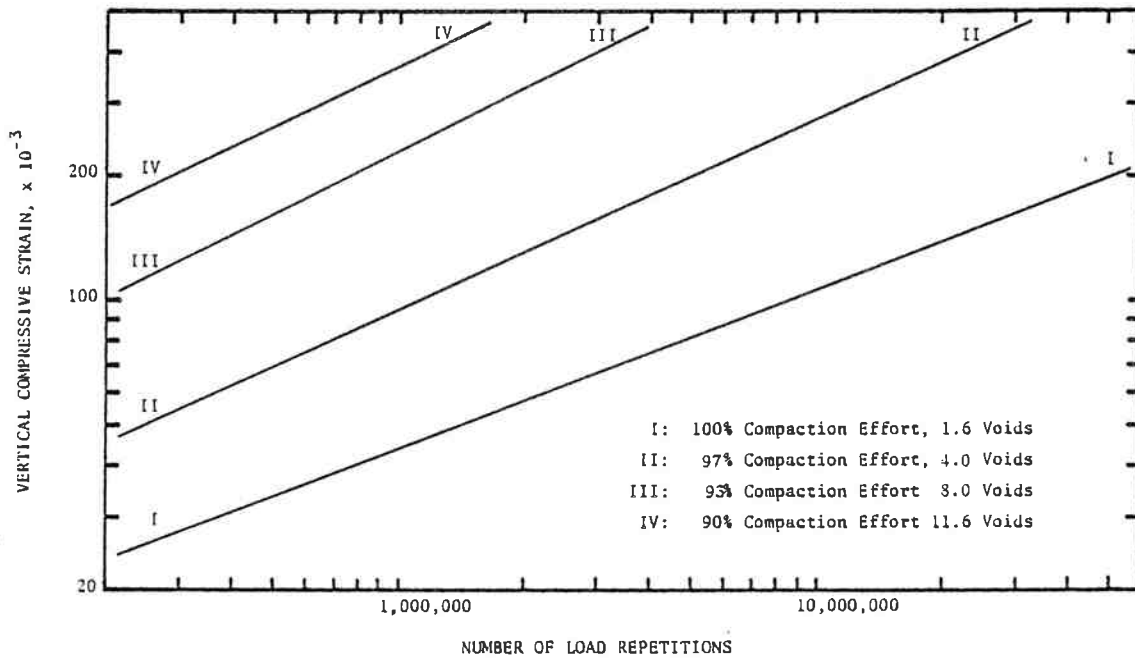

Figure 22a. Influence of Mix Density on Permanent Deformation
As Compacted Samples
6% Passing No. 200 - 25% Passing No. 10 - 5.5% Asphalt

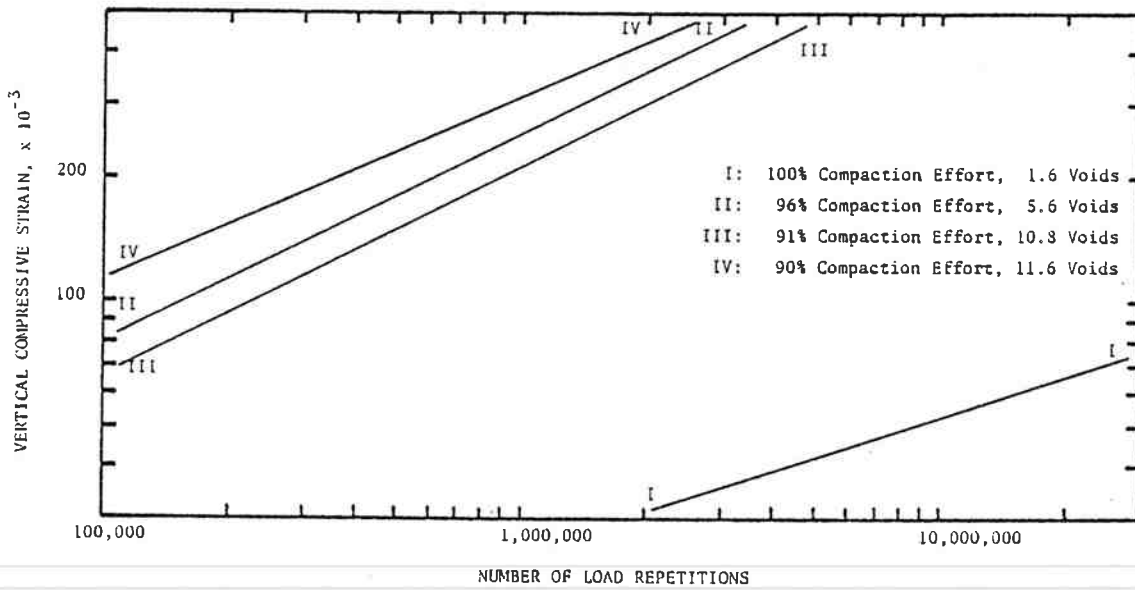

Figure 22b. Influence of Mix Density on Permanent Deformation,
Conditioned Samples.
6% Passing No. 200 - 25% Passing No. 10 - 5.5% Asphalt

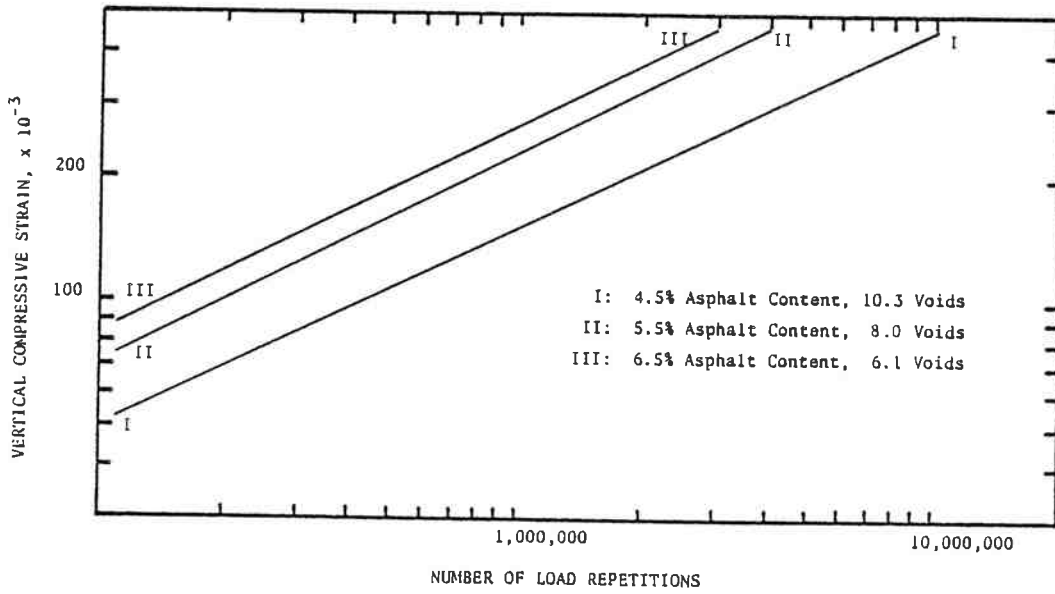

Figure 23a. Influence of Asphalt Content on Permanent Deformation, As Compacted Samples.
6% Passing No. 200 - 25% Passing No. 10 - 93% Compaction

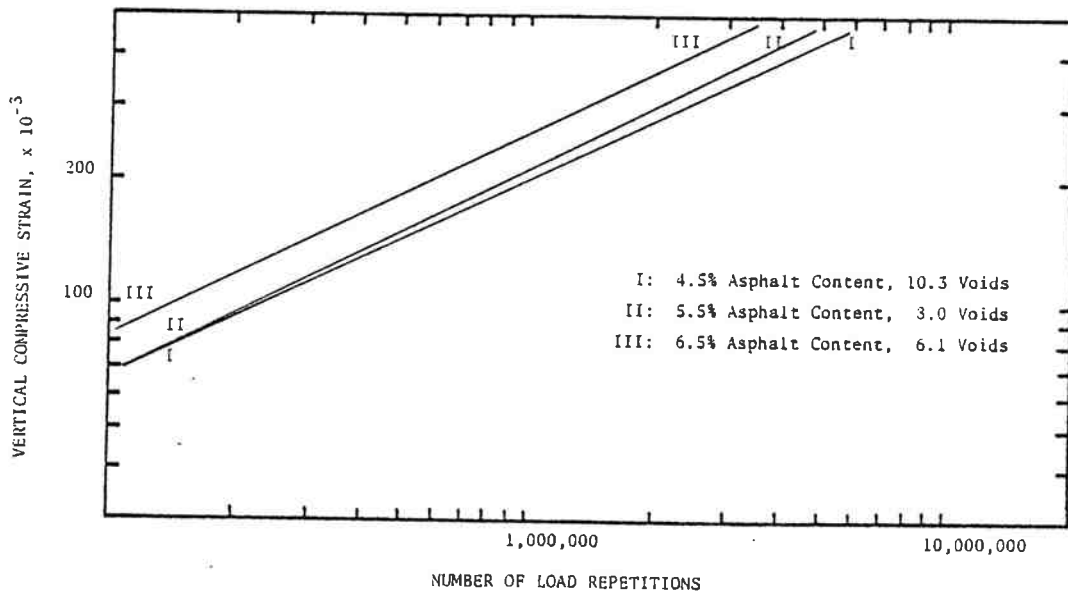

Figure 23b. Influence of Asphalt Content on Permanent Deformation, Conditioned Samples.
6% Passing No. 200 - 25% Passing No. 10 - 93% Compaction.

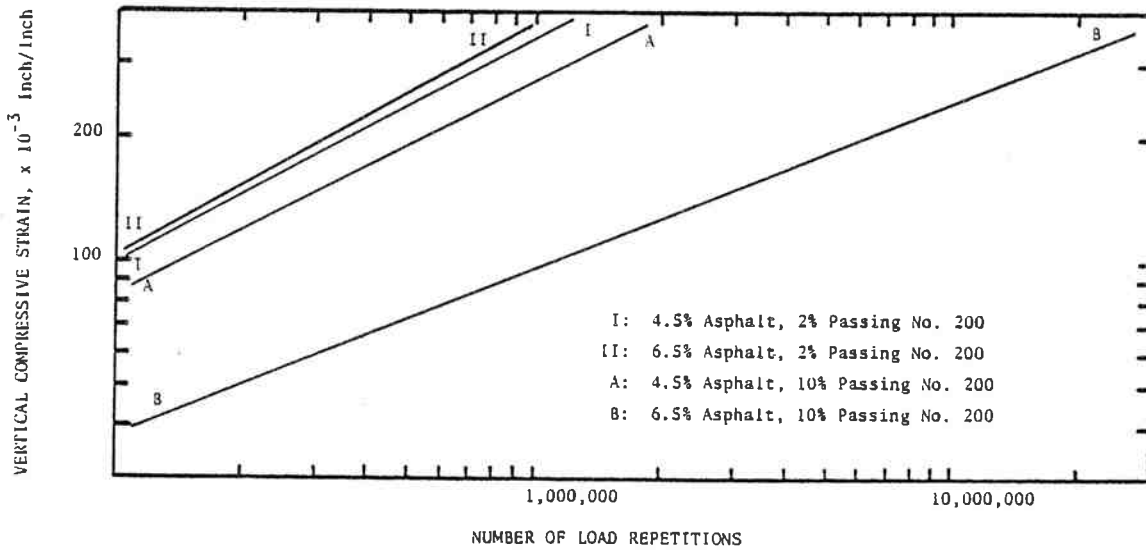

Figure 24a. Influence of Asphalt Content on Permanent Deformation - As Compacted Samples. 2 and 10% Passing No. 200, 25% Passing No. 10, 93% Compaction.

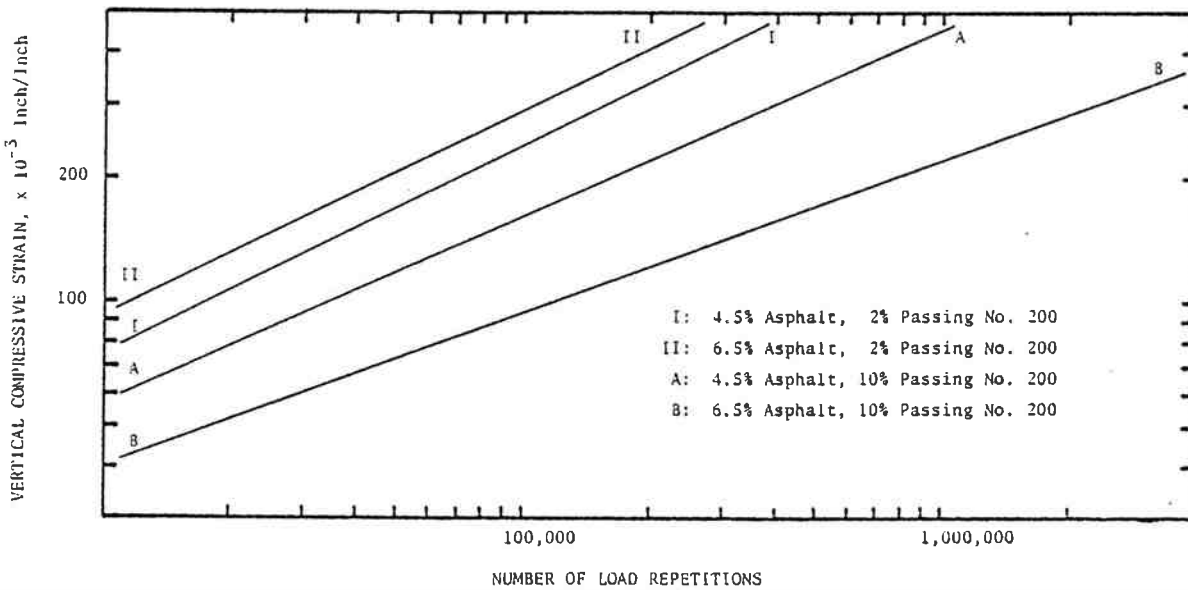

Figure 24b. Influence of Asphalt Content on Permanent Deformation - Conditioned Samples. 2 and 10% Passing No. 200, 25% Passing No. 10, 91% Compaction.

amount of fines decreases the mix susceptibility to permanent deformation. Both as-compacted and conditioned data indicate an interaction between asphalt content and amount of fines. For a low amount of fines (2%), increasing the asphalt content from 4.5 to 6.5% increases the mix susceptibility to permanent deformation. However, for 10% passing No. 200 sieve, the test results indicate a decrease in the mix susceptibility to permanent deformation when the asphalt content is increased. The influence of the percent passing the No. 200 sieve is more clearly shown in Figures 25 and 26. As-compacted and conditioned samples indicate that an increase in the percent passing the No. 200 sieve decreases the mix susceptibility to permanent deformation.

In summary, the mix permanent deformation will be minimized when:

- (1) the mix level of compaction is increased,
- (2) the amount passing the No. 200 sieve is increased, and
- (3) the asphalt content is decreased.

Indirect Tensile Strength Test Data

For each set of conditions considered in this study, 4 samples have been tested for indirect tensile strength. Two samples were tested as-compacted, and two samples were tested after conditioning. Test results have been summarized in Table 16. Resilient modulus was measured on all samples before running the indirect tensile test. Table 16a gives the average as-compacted resilient modulus and tensile strength. For the conditioned samples, resilient modulus was measured both before and after conditioning. These data are recorded in Table 16b along with the conditioned tensile strength.

Relationship between the resilient modulus and the indirect tensile is shown in Figure 27a for the as-compacted data and in Figure 27b for the conditioned data. The coefficient of correlation is in both cases very low, which indicates a poor correlation between the mix resilient modulus and the mix tensile strain.

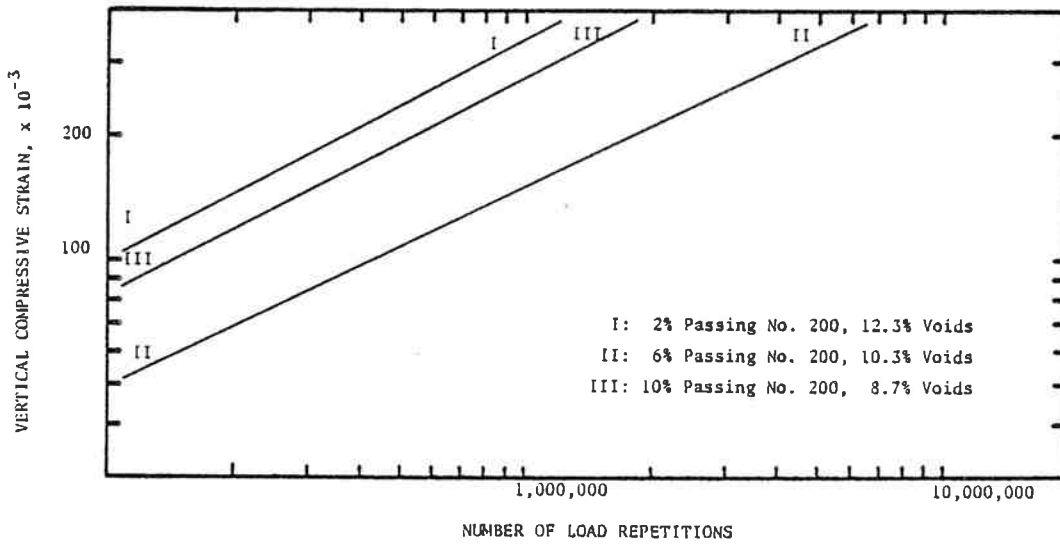

Figure 25a. Influence of Passing No. 200 on Permanent Deformation, As Compacted Samples 25% Passing No. 10 - 4.5% Asphalt - 93% Compaction.

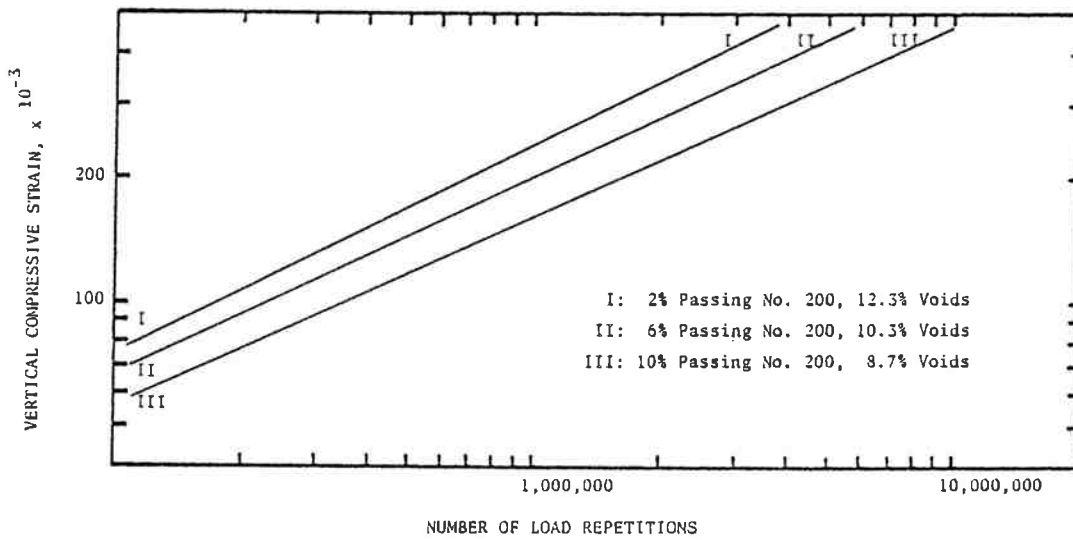

Figure 25b. Influence of Passing No. 200 on Permanent Deformation - Conditioned Samples. 25% Passing No. 10 - 4.5% Asphalt - 93% Compaction.

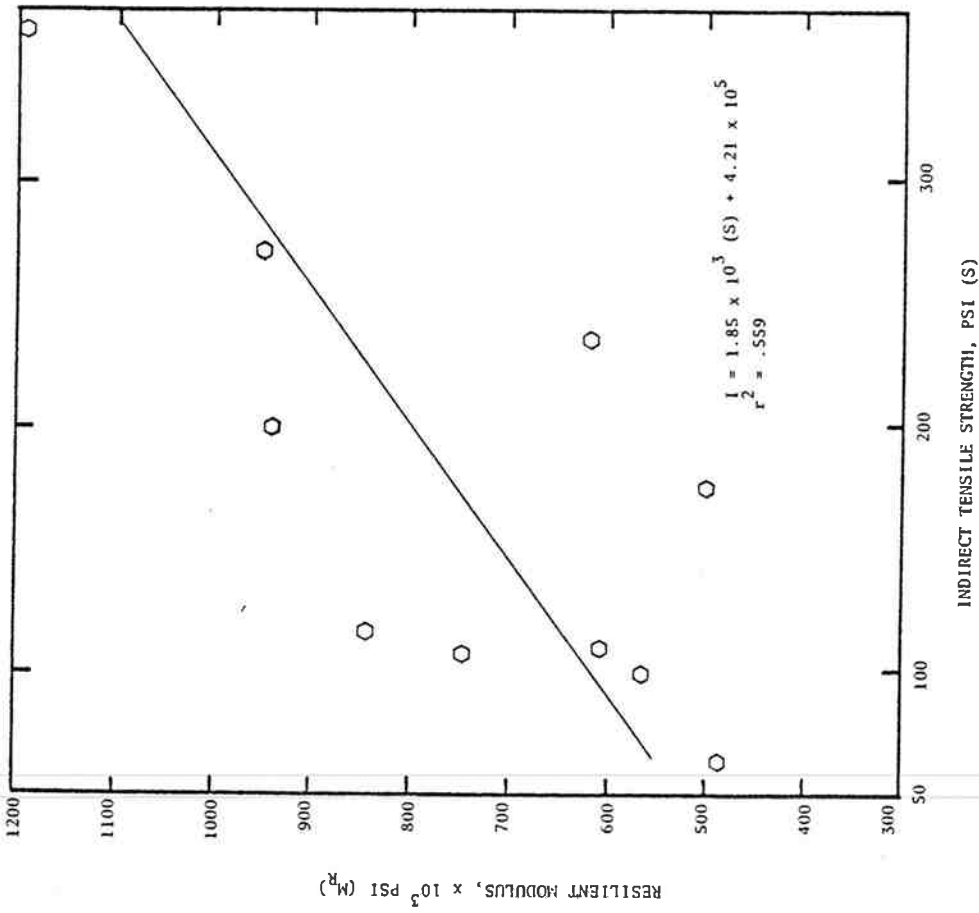

Figure 27a. Relationship Between Indirect Tensile Strength and Resilient Modulus - As Compacted Samples.

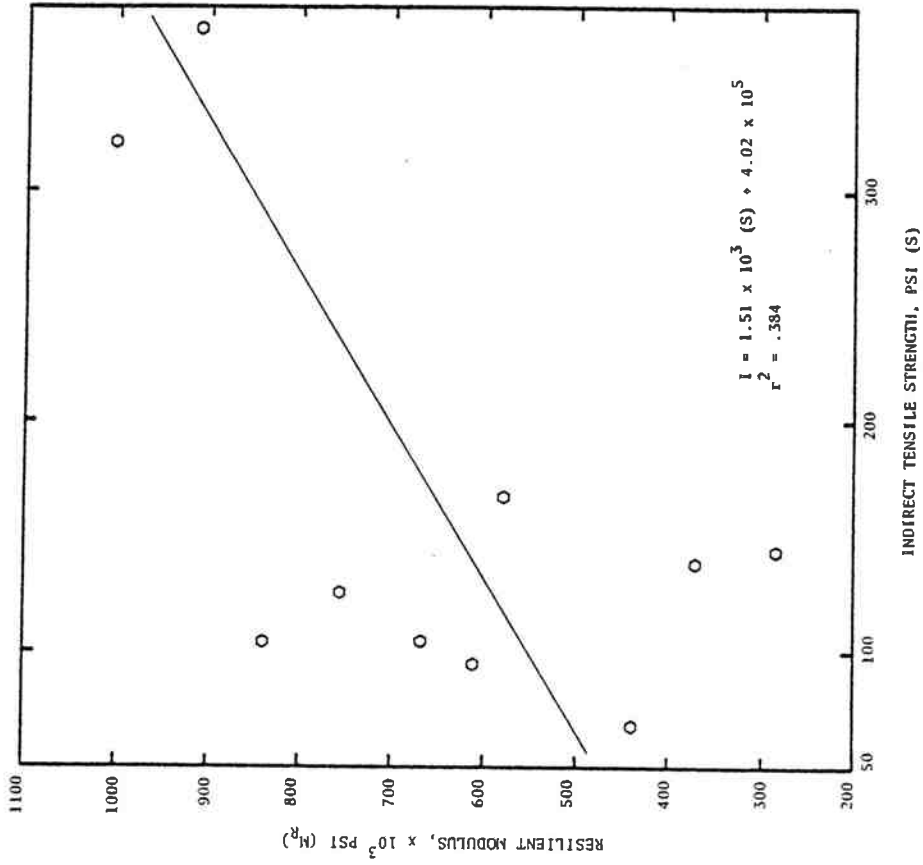

Figure 27b. Relationship Between Indirect Tensile Strength and Resilient Modulus - Conditioned Samples.