

**OREGON OCCUPATIONAL
SAFETY AND HEALTH STANDARDS**

Oregon Administrative Rules, Chapter 437

**DIVISION 2 (29 CFR 1910)
GENERAL OCCUPATIONAL SAFETY & HEALTH RULES**



SUBDIVISION L:

FIRE PROTECTION

(OAR 437-002-0182

Oregon Rules for Fire Fighters)

(1910.155 - 1910.165)

Oregon Occupational Safety and Health Division (OR-OSHA)
Department of Consumer and Business Services
Salem, Oregon 97301-3882

AO 3-2005

The Oregon Department of Consumer and Business Services adopted these rules pursuant to ORS 654.025(2).

The Secretary of State Designated OAR Chapter 437 as the “Oregon Occupational Safety and Health Code.” Six general subject areas within this code are designated as “Divisions.”

- **Division 1** General Administrative Rules
- **Division 2** General Occupational Safety and Health Rules
- **Division 3** Construction
- **Division 4** Agriculture
- **Division 5** Maritime Activities
- **Division 7** Forest Activities
- **Oregon Revised Statutes (ORS)** 654 The Oregon Safe Employment Act (OSEAct)

Oregon-initiated rules in this division of the Oregon Occupational Safety and Health Code are numbered in a uniform system developed by the Secretary of State. This system does not number the rules in sequence (001, 002, 003, etc.). Omitted numbers may be assigned to new rules at the time of their adoption.

Oregon-initiated rules are arranged in the following Basic Codification Structure adopted by the Secretary of State for Oregon Administrative Rules (OAR):

| Chapter | Division | Rule | Section | Subsection | Paragraphs |
|---------|----------|------|---------|------------|------------|
| 437 | 002 | 0322 | (1) | (a) | (A)(i)(I) |

The majority of Oregon OSHA codes are adopted by reference from the Code of Federal Regulations (CFR), and are arranged in the following basic federal numbering system:

| Chapter | Division | Part | Subpart (Subdivision) | Section | Paragraphs |
|---------|----------|------|--------------------------|---------|------------|
| 437 | 002 | 1910 | S | .303 | (a) |

The terms “subdivision” and “subpart” are synonymous within OAR 437, Oregon Occupational Safety and Health Code.

To obtain an order form or copies of these codes, address:

**Department of Consumer & Business Services
Oregon Occupational Safety & Health Division (OR-OSHA)
350 Winter St. NE, Room 430
Salem, OR 97301-3882**

Or call the OR-OSHA Resource Library at 503-378-3272

The rules referenced in this division are available for viewing in the Office of the Secretary of State, Administrative Rules and Office Document Section, Oregon State Archives Building, Salem, Oregon 97310, or the Central Office, Oregon Occupational Safety and Health Division of the Department of Consumer and Business Services, Room 430, 350 Winter St. NE Salem, OR 97301-3882. Please visit our web site at: www.orosha.org

NOTES:

The following federal standards on **Fire Protection** (29 CFR 1910.155 through .165 and Appendices A through E) have been adopted by reference as **Division 2/L, Fire Protection**, by OR-OSHA Admin. Order 14-1993, filed 8/27/93, **EFFECTIVE 11/1/93**.

Former Oregon Division 61, Fire Protection, is repealed in its entirety when these rules become effective. However, the majority of rules in former Oregon Division 151, **Fire Fighters**, have been updated and revised, and have been renumbered as part of Division 2/L (see OAR 437-002-0182).

Oregon OSHA adopted by reference corrections and technical amendments issued by federal OSHA and published in the Federal Register. Federal OSHA made simple corrections, deleted redundant provisions, and clarified and reorganized various other provisions throughout the standards. OR-OSHA Admin. Order 4-1997, filed 4/2/97, effective 4/2/97.

Oregon OSHA adopted revisions and additions to the Oregon Rules for Fire Fighters, 437-002-0182 in Division 2/L. The amendments to this rule set performance-oriented criteria that will lead to better protection for Oregon fire fighters, and reflect advancements in equipment availability, technology and acceptance. Personal protective equipment requirements specifically have been upgraded. New language simplifies and clarifies parts of the existing standard. OR-OSHA Admin. Order 2-1998, filed 3/11/98, effective 3/11/98.

Federal OSHA published in the Federal Register the new Respiratory Protection Standard. The new standard replaces respiratory protection standards that were adopted in 1971 by OSHA. The **new respiratory protection text is in general industry, 29 CFR 1910.134**. The text previously in 1910.134 has been redesignated as 1910.139, Respiratory Protection for M. Tuberculosis. Four subdivisions in the Construction standard have also been amended. OR-OSHA Admin. Order 3-1998, filed 7/7/98, effective 7/7/98.

Federal OSHA made amendments in general industry and construction in both safety and health standards that will revise or eliminate duplicative, inconsistent, or unnecessary regulatory requirements without diminishing employee protections. Changes being made to health standards include reducing the frequency of required chest x-rays and eliminating sputum-cytology examinations for workers covered by the coke oven and inorganic arsenic standards, and changing the emergency-response provisions of the vinyl chloride standard. Changes being made to OSHA safety standards include eliminating the public safety provisions of the temporary labor camp standard, eliminating unnecessary cross-references in the textile industry standards, and others. OR-OSHA Admin. Order 4-1999, filed 4/30/99, effective 4/30/99.

Oregon OSHA adopted revisions and additions to the Oregon initiated OAR 437-002-0182, Oregon Rules for Fire Fighters, in Division 2/L, with OR-OSHA Admin. Order 2-2000, filed January 28, 2000, effective January 28, 2000.

The revisions update and eliminate conflicts between the existing Oregon Rules for Fire Fighters, OAR 437-002-0182, and the adopted Respiratory Protection standard (1910.134), in Division 2/L, Personal Protective Equipment. The revisions and additions change the requirement for medical evaluations, respirator fit testing and training. Compliance with the revisions and additions will provide a higher standard of protection against injury and illness for Oregon fire fighters.

L FIRE PROTECTION

These rules apply to any and all activities, operations and equipment of employers and employees involved in providing fire protection services, and other emergency first response and related activities, which are subject to the provisions of the Oregon Safe Employment Act. These rules do not apply to the following exempted fire fighting activities:

Aircraft fire fighting and rescue.

Forest and uncultivated, wildland fire fighting.

Private industry fire brigades.

Marine fire fighting and rescue.

Oregon OSHA Admin. Order 12-2001, filed and effective October 26, 2001. This change clarifies some confusing OSHA language and points readers to the source. This also changes our term for basic firefighter training to the language used by the Oregon Department of Public Safety Standards and Training (DPSST) for Entry Level Firefighters.

This is OR-OSHA Administrative Order 3-2005, adopted and effective June 10, 2005.

In late 2003 Oregon OSHA discovered that the requirements for live fire training, in OAR 437-002-0182(10)(c), are not usable, and in fact, don't exist. The Oregon State Fire Marshal's standard (OAR 837-010-0070(3)(b)(c) and (d)), referenced in Oregon OSHA's rule, was repealed several years ago, and no other standard has been adopted in its place.

OR-OSHA contacted some fire departments, and DPSST to review a variety of programs for live fire training. It became clear that the programs, though different, were usually based on the NFPA standard for live fire training. Oregon OSHA decided to ask for assistance from the Oregon OSHA Fire Fighters Advisory Committee (a standing committee with representatives from various parts of the Fire Service) to select, or develop a standard for live fire training. The first meeting was held in March 2004, followed by five more meetings, ending in November. The Committee based the development of a new standard, focused on occupational safety and health of fire fighters during live fire training, on NFPA 1403, Live Fire Training. Acceptable sources of ignition became a major topic. A petition for the use of drip torches was sent to the NFPA 1403 Subcommittee on Ignition Sources. The subcommittee agreed that ignition sources need to be addressed in the next (2007) draft of NFPA 1403. Unofficial acceptance by the subcommittee was given for the use of fusees. After further studying the use and safety of drip torches, the Oregon OSHA Fire Fighters Advisory Committee recommended allowing use of drip torches in the standard. Another major topic for discussion was calculation of water supply. Consensus of the committee was to use the calculations of NFPA 1142, 2001 edition, for the minimum water supply.

Adopted amendments are in Division 2/L, Oregon Rules for Fire Fighters standard OAR 437-002-0182(10)(c) and a new mandatory Appendix C to 437-002-0182(10)(c), Minimum Requirements for Live Fire Training.

The Oregon-initiated rules are printed *in italics* in this codebook.

TABLE OF CONTENTS

| | | |
|---------------------|---|------|
| 437-002-0180 | <i>Adoption by Reference</i> | L-1 |
| 437-002-0182 | <i>Oregon Rules for Fire Fighters</i> | L-3 |
| <i>Appendix A</i> | <i>Protective Apparel and Respirators (Nonmandatory)</i> | L-17 |
| <i>Appendix B</i> | <i>Apparatus Operation Signal Communication (Nonmandatory)</i> | L-19 |
| <i>Appendix C</i> | <i>Minimum Requirements for Live Fire Training – Mandatory appendix as required by OAR 437-002-0182(10)(c)</i> | L-21 |
| 1910.155 | Scope, Application and Definitions Applicable to This Subdivision..... | L-27 |
| 1910.156 | Fire Brigades..... | L-33 |
| 1910.157 | Portable Fire Extinguishers..... | L-39 |
| 1910.158 | Standpipe and Hose Systems..... | L-45 |
| 1910.159 | Automatic Sprinkler Systems | L-47 |
| 1910.160 | Fixed Extinguishing Systems, General | L-49 |
| 1910.161 | Fixed Extinguishing Systems, Dry Chemical..... | L-53 |
| 1910.162 | Fixed Extinguishing Systems, Gaseous Agent | L-55 |
| 1910.163 | Fixed Extinguishing Systems, Water Spray and Foam | L-57 |
| 1910.164 | Fire Detection Systems..... | L-59 |
| 1910.165 | Employee Alarm Systems..... | L-61 |
| | Appendix A to Subdivision L – Fire Protection..... | L-63 |
| | Appendix B to Subdivision L – National Consensus Standards..... | L-83 |
| | Appendix C to Subdivision L – Fire Protection References for Further Information..... | L-85 |
| | Appendix D to Subdivision L – Availability of Publications Incorporated by Reference in Section 1910.156, Fire Brigades..... | L-91 |
| | Appendix E to Subdivision L – Test Methods for Protective Clothing | L-93 |

OAR 437, DIVISION 2

GENERAL OCCUPATIONAL SAFETY AND HEALTH RULES

SUBDIVISION L – FIRE PROTECTION

437-002-0180 Adoption by Reference. *In addition to and not in lieu of any other health and safety codes contained in OAR Chapter 437, the Department adopts by reference the following federal rules as printed in the Code of Federal Regulations, 29 CFR 1910, revised as of 7/1/98, and any sub-sequent amendments published in the Federal Register as listed below:*

- (1) 29 CFR 1910.155 **Scope, application and definitions applicable to this subpart**, published 9/12/80, Federal Register, vol. 45, p. 60704; amended 4/12/88, FR vol. 53, p. 12122.
- (2) 29 CFR 1910.156 **Fire brigades**, published 9/12/80, FR vol. 45, p. 60706; amended 5/1/81, FR vol. 46, p. 24557; 4/30/84, FR vol. 49, p. 18295; 3/7/96, FR vol. 61, no. 46, p. 9239; 1/8/98, FR vol. 63, no. 5, p. 1284; 6/18/98, FR vol. 63, no. 117, p. 33467.
- (3) 29 CFR 1910.157 **Portable fire extinguishers**, published 9/12/80, FR vol. 45, p. 60708; amended 5/1/81, FR vol. 46, p. 24557; 9/29/86, FR vol. 51, p. 34560; 3/7/96, FR vol. 61, no. 46, p. 9239; amended with AO 12-2001, Oregon note added, f. and ef. 10/26/01.
- (4) 29 CFR 1910.158 **Standpipe and hose systems**, published 9/12/80, FR vol. 45, p. 60710; 3/7/96, FR vol. 61, no. 46, p. 9239.
- (5) 29 CFR 1910.159 **Automatic sprinkler systems**, published 9/12/80, FR vol. 45, p. 60710; amended 5/1/81, FR vol. 46, p. 24557.
- (6) 29 CFR 1910.160 **Fixed extinguishing systems, general**, published 9/12/80, FR vol. 45, p. 60711; amended with AO 12-2001, Oregon note added, f. and ef. 10/26/01.
- (7) 29 CFR 1910.161 **Fixed extinguishing systems, dry chemical**, published 9/12/80, FR vol. 45, p. 60712.
- (8) 29 CFR 1910.162 **Fixed extinguishing systems, gaseous agent**, published 9/12/80, FR vol. 45, p. 60712; amended 5/1/81, FR vol. 46, p. 24557.
- (9) 29 CFR 1910.163 **Fixed extinguishing systems, water spray and foam**, published 9/12/80, FR vol. 45, p. 60712.
- (10) 29 CFR 1910.164 **Fire detection systems**, published 9/12/80, FR vol. 45, p. 60713; amended with AO 12-2001, Oregon note added, f. and ef. 10/26/01.

L FIRE PROTECTION

- (11) 29 CFR 1910.165 **Employee alarm systems**, published 9/12/80, FR vol. 45, p. 60713.
- (12) Appendix A to Subpart L – Fire protection, published 9/12/80, FR vol. 45, p. 60715; amended 5/1/81, FR vol. 46, p. 24557.
- (13) Appendix B to Subpart L – National consensus standards, published 9/12/80, FR vol. 45, p. 60715; amended 6/30/93, FR vol. 58, no. 124, p. 35309.
- (14) Appendix C to Subpart L – Fire protection references for further information, published 9/12/80, FR vol. 45, p. 60715; amended 6/30/93, FR vol. 58, no. 124, p. 35309.
- (15) Appendix D to Subpart L – Availability of publications incorporated by reference in Section 1910.156, Fire Brigades, published 9/12/80, FR vol. 45, p. 60715; amended 6/30/93, FR vol. 58, no. 124, p. 35309; 3/7/96, FR vol. 61, no. 46, p. 9239.
- (16) Appendix E to Subpart L – Test methods for protective clothing, published 9/12/80, FR vol. 45, p. 60715; amended 5/1/81, FR vol. 46, p. 24557.

These standards are available from the Oregon Occupational Safety and Health Division (OR-OSHA), Department of Consumer and Business Services; and the United States Government Printing Office.

Stat. Auth.: ORS 654.025(2) and 656.726(4).

Stat. Implemented: ORS 654.001 through 654.295.

Hist: OR-OSHA Admin. Order 14-1993, f. 8/27/93, ef. 11/1/93.
OR-OSHA Admin. Order 4-1997, f. 4/2/97, ef. 4/2/97.
OR-OSHA Admin. Order 3-1998, f. 7/7/98, ef. 7/7/98.
OR-OSHA Admin. Order 4-1999, f. 4/30/99, ef. 4/30/99.
OR-OSHA Admin. Order 12-2001, f. 10/26/01, ef. 10/26/01.

437-002-0182 Oregon Rules for Fire Fighters.

(1) Scope and Application.

(a) These rules shall apply to any and all activities, operations and equipment of employers and employees involved in providing fire protection services, and other emergency first response and related activities, which are subject to the provisions of the Oregon Safe Employment Act. These rules shall not apply to the following exempted fire fighting activities:

(A) Aircraft fire fighting and rescue;

(B) Forest and uncultivated, wildland fire fighting;

(C) Private industry fire brigades.

(D) Marine Fire Fighting and rescue.

EXCEPTION: *When a public fire department elects to participate in one or more of the exempted fire fighting activities, that fire department shall comply with all of the provisions of OAR 437-002-0182.*

(b) The provisions of OAR 437-002-0182 shall be supplemented by the provisions of other applicable safety and health rules of OR-OSHA.

(2) Definitions.

Aerial device: *An aerial ladder, elevating platform, aerial ladder platform, or water tower that is designed to position personnel, handle materials, provide egress and discharge water.*

Afterflame: *The time a test specimen continues to flame after the flame source has been removed.*

ANSI: *American National Standards Institute.*

Apparatus: *A mobile piece of fire fighting equipment such as pumper, water tender, etc.*

Drill tower: *A structure which may or may not be attached to the station and which is principally used for nonclassroom training of the fire fighters in fire service techniques, and which is over two stories in height.*

Emergency incident: *Any situation to which the fire department responds to deliver emergency services, including rescue, fire suppression, medical treatment, and other forms of hazard control and mitigation.*

Emergency scene: *The site where the suppression of a fire or the emergency exists.*

Fire chief: *An employer representative responsible for managing the fire department's operation.*

Fire fighter:

(1) A person involved in performing fire department duties and responsibilities, which include fire suppression.

(2) A fire fighter may be a career or volunteer member of a fire department and may occupy any position or rank within the fire department.

Fire retardant: *A material to reduce, stop or prevent flame spread.*

Fire training: *Training received by fire fighters to maintain proficiency in the performance of their assigned duties.*

Flame-resistance: *The property of materials, or combinations of component materials, to retard ignition and restrict the spread of flame.*

Hazardous material incident: *The accidental release of hazardous materials from their containers.*

Helmet: *A head protective device consisting of a rigid shell, energy absorption system, and chin strap intended to be worn to provide protection for the head or portions thereof, against impact, flying or falling objects, electric shock, penetration, heat and flame.*

Hose tower: *A vertical structure where hose is hung to dry.*

IFSTA: *International Fire Service Training Association.*

Lifeline: *Length of rope to which employees are secured when in extremely hazardous areas.*

Live fire training: *Any fire set within a structure, tank, pipe, pan, etc., under controlled conditions to facilitate the training of fire fighters under actual fire conditions.*

MSHA: *Mine Safety and Health Administration.*

NFPA: *National Fire Protection Association.*

Nondestructive testing: *A test to determine the characteristics or properties of a material or substance that does not involve its destruction or deterioration.*

Private Industry Fire Brigades: *A group of employees within an industry who are required to fight interior structural fires at their place of employment.*

Protective clothing: *The clothing or equipment worn to protect the head, body and extremities from chemical, physical and health hazards.*

Quick disconnect valve: *A device which starts the flow of air by insertion of the hose which leads from the facepiece into the regulator of self-contained breathing apparatus, and stops the flow of air by disconnection of the hose from the regulator.*

Rescue saw (Cutoff saw): A powered saw with a large circular cutting blade covered in part by a movable guard used to cut metal, wood, or concrete enclosures.

Respirators:

(1) **Atmosphere-supplying respirators:** May be self-contained in which a cylinder of air or oxygen or an oxygen generating chemical provides the necessary oxygen for breathing, or a hose-type respirator in which the air is supplied from an external source.

(2) **Air-purifying respirators:** Contain chemical cartridges and/or filters to remove the contaminant prior to breathing.

(3) **Positive Pressure demand respirators (Positive pressure respirators):** Types of respirators which constantly and automatically maintain a positive pressure in the mask by the introduction of air when a spring-loaded valve senses that the positive pressure has been lowered because of inhalation or the leakage of air from the mask.

Responding: The act of answering an emergency call or other alarm.

Scabbard: A guard which will prevent accidental injury and which covers the blade and pick of an axe or other sharp instrument when worn by the fire fighter.

SCBA: A self-contained breathing apparatus designed to provide the wearer with a supply of respirable air carried in and/or generated by the breathing apparatus. This apparatus requires no intake of air or oxygen from the outside atmosphere, and can be designed to be a demand or pressure demand type respirator.

Station (Fire station): Structure in which fire service apparatus and/or personnel are housed.

Tailboard: Standing space at rear of an engine or pumper apparatus where fire fighters ride.

Training: The process of making proficient through instruction and hands-on practice in the operation of equipment, including respiratory protection equipment, that is expected to be used and in the performance of assigned duties.

Warning light: A flashing or rotating light.

GENERAL REQUIREMENTS

(3) **Organizational statement.** The employer shall prepare and maintain a statement or written policy which includes basic organizational structure and functions of the organization, in addition to the type, amount, and frequency of training to be provided to fire fighters. This statement shall be made available for inspection by the Administrator and by employees or their designated representatives.

(4) Personnel.

(a) The employer shall review and evaluate the physical capability of each employee annually to determine their ability to perform duties which may be assigned. The review and evaluation shall be accomplished through physical examination, stress testing or satisfactory performance demonstrated during the performance of their assigned duties.

(b) The employer shall not permit an employee with known medical condition which would significantly impair their ability to engage in fire suppression activities at the emergency scene unless a physician's certificate of the employees' fitness to participate in such activities is provided. This shall not limit the employer's ability to assign personnel to support activities (versus fire suppression activities).

(5) Employer's Responsibility.

(a) Each employer shall comply with the provisions of this division to protect the life, safety, and health of employees.

(b) It shall be the responsibility of the employer to establish and supervise:

(A) A safe and healthful working environment, as it applies to nonemergency conditions or to emergency conditions at the scene after the incident has been terminated, as determined by the officer in charge; and

(B) Programs for training employees in the fundamentals of accident prevention.

(C) A safe and healthful working environment, as it applies to live fire training exercises.

(c) The employer shall maintain all equipment in a safe condition.

(d) The employer shall see that employees who participate in exempted fire fighting activities listed in OAR 437-002-0182(1) are properly trained, protected, clothed and equipped for the known hazards of that particular emergency operation.

The following note refers to the Respiratory Protection Standard, 1910.134(g)(3) and (4), Procedures for Interior Structural Fire Fighting ("two-in/two-out rule") adopted in Oregon July 7, 1998.

NOTE: If, upon arriving at the scene, members find an imminent life threatening situation where immediate action may prevent the loss of life or serious injury, the requirements for personnel in the outside standby mode may be suspended, when notification is given by radio to incoming companies that they must provide necessary support and backup upon their arrival.

(6) Employee's Responsibility.

- (a) Each fire fighter shall comply with the provisions of OAR 437-002-0182 which are applicable to his/her own actions and conduct in the course of his/her employment.*
- (b) Fire fighters shall notify the appropriate employer and/or safety committee representative of unsafe practices and of unsafe conditions of equipment apparatus or workplaces.*
- (c) All fire fighters, at regularly scheduled times, shall attend required training and/or orientation programs designed to increase their competency in occupational safety and health.*
- (d) Fire fighters and other employees shall apply the principles of accident prevention in their work. They shall use all required safety devices and protective equipment.*
- (e) Each fire fighter shall take proper care of his/her protective equipment.*
- (f) Fire fighters who are expected to perform fire fighting operations shall notify their employer when health conditions arise or are discovered that will limit their capability of performing those duties.*

(7) Safety Committee.

- (a) A fire department safety committee shall be established and administered by public or private employers in accordance with the requirements of OAR 437-001-0765 in Division 1, General Administrative Rules.*
- (b) When applicable, the representation on the safety committee shall include both career and volunteer fire fighters.*

(8) Incident Management. *An incident management system that meets the requirements of NFPA standard 1561, on Fire Department Incident Management, shall be established with written standard operating procedures, applying to all members involved in emergency operations. All members involved in emergency operations shall be familiar with the system.*

(9) Accountability.

- (a) The fire department shall establish written standard operating procedures for a personnel accountability system in accordance with Section 2-6, 1995 of NFPA 1561, standard on Fire Department Incident Management System, by January 1, 1999, that provides for the tracking and inventory of all members operating at an emergency incident.*
- (b) It shall be the responsibility of all members operating at an emergency incident to actively participate in the personnel accountability system.*

(10) Fire Fighting Training and Education.

- (a) The employer or employer representative shall establish and implement a policy for the delivery of education and training designed to develop and maintain an appropriate level of knowledge, skill, and ability throughout the fire fighting classifications (ranks). Such education and training shall be provided to fire fighters before they perform assigned duties on a continuing basis.*
- (b) Before fire fighters participate in structural fire fighting activities, or in live fire training in a structure, they shall meet the training levels prescribed by the Department of Public Safety Standards and Training's (DPSST) 'Entry-level Firefighter' or have equivalent training.*
- (c) When live fire training occurs, it must be conducted under the direction of the fire department training officer, or employer authorized representative. All live fire training must be conducted following the requirements of Appendix C of this standard.*
- (d) During live fire training, fire fighters shall wear the protective equipment normally required for that type of fire fighting.*
- (e) When rope rescue training occurs, it shall be conducted under the direction of the fire department training officer or department-designated authority in accordance with the equipment manufacturers' recommendations. The training officer shall keep records of the manufacturers' training requirements, and shall comply with all such requirements.*
- (f) All fire hoses used by fire departments for training and fire combat shall meet the service testing requirements noted in Chapter 5 of NFPA 1962, 1993 edition.*
- (g) The employer shall provide training for the purpose, proper selection, fitting, use, and limitations of personal protective equipment.*
- (h) The employer shall assure that each employee is informed of the procedure of reporting unsafe work conditions or equipment.*

(11) General Requirements for Protective Clothing.

- (a) The employer shall provide to employees all required protective clothing, except that an employee at the employee's option may supply protective clothing. The employer shall provide the protective clothing at no cost to employees. The protective clothing must meet the requirements in OAR 437-002-0182(11) through (16), whether supplied by the employer or employee.*
- (b) The employer shall assure that new protective clothing intended for structural fire fighting which is ordered, used or purchased after the effective date of this division, meets the requirements contained in OAR 437-002-0182(11) through (16). The employer shall assure that fire fighters wear this clothing when performing structural fire fighting.*

(c) In situations other than structural fire fighting, the employer shall ensure that protective clothing appropriate for the known hazards of that particular emergency operation is worn.

(d) Protective clothing currently in use which does not meet the requirements of OAR 437-002-0182(11) through (16) may continue to be used until October 1, 1998, if it was designed for fire fighting purposes and meets the manufacturer's original specifications and maintains the protective capabilities for which it was designed.

(e) The employer shall assure that appropriate protective clothing protects the head, body, and extremities and consists of at least the following components: foot and leg protection, hand protection, body protection, and eye, face and head protection.

(12) Body Protection.

(a) Body protection shall be as follows to ensure full body protection for the wearer.

(b) Coats and trousers used by structural fire fighters shall be at least equivalent to the National Fire Protection Association (NFPA) standard, No. 1971, 1991 edition, entitled "Protective Clothing for Structural Fire Fighting." (See also Appendix A.)

(13) Head Protection.

(a) Head protection shall consist of a protective head device, ear protection, flaps and chin strap which meet the requirements of NFPA Standard 1971-2000, Protective Ensemble for Structural Fire Fighting.

(b) Use, care, alterations and maintenance instructions for protective headgear shall be supplied for each helmet.

(c) Care, maintenance, and alteration of helmets shall conform to the manufacturer's recommendations.

(d) During structural fire fighting helmet accessories designed to provide or maintain protection from health and safety hazards shall be worn in the manufacturer's recommended position. (See also Appendix A.)

(e) A flame-resistant protective hood which will not adversely affect the seal of a respirator facepiece and meeting the requirements of NFPA Standard 1971, 1996 edition, after January 1, 1999 shall be worn during interior structural fire fighting operations to protect the sides of the face and hair.

(14) Hand Protection.

(a) Hand protection for fire fighting activities shall consist of protective gloves or glove system which will provide protection against cut, puncture, and heat penetration. Gloves or glove system shall meet the requirements of NFPA Standard 1973, 1988 edition, titled "Gloves for Structural Fire Fighting."

(15) Foot and Leg Protection.

(a) Foot and leg protection shall meet the requirements of OAR 437-002-0182(15)(a)(A) and (B) and may be achieved by either of the following methods:

(A) Fully extended boots which provide protection for the legs; or

(B) Protective shoes or boots worn in combination with protective trousers that meet the requirements of OAR 437-002-0182(12).

(b) Protective footwear shall meet the requirements of NAPA Standard 1974, 1992 edition, titled "Protective Footwear for Structural Fire Fighting."

(c) Fire fighters' boots may be resoled but must meet the requirements of this rule.

(16) Eye and Face Protection. *Eye and face protection worn by fire fighters at the fire ground shall comply with the following regulations:*

(a) General requirements. Face protection shall be required where there is a reasonable probability of injury that can be prevented by such protection, when such face protection does not protect the eyes from foreign objects additional eye protection shall be provided.

(b) When self-contained respiratory equipment is being utilized by fire fighters, additional eye and face protection will not be required.

Employers shall make conveniently available a type of protection suitable for the work to be performed, and employees shall use such protectors. Protectors shall meet the following minimum requirements.

(A) They shall provide adequate protection against the particular hazards for which they are designed.

(B) They shall be reasonably comfortable when worn under the designated conditions.

(C) They shall be durable.

(D) They shall be capable of being disinfected.

(E) They shall be easily cleanable.

(F) Protectors that can be worn over corrective lenses shall be available for those who need them, and should be kept clean and in good repair.

(c) Face shields.

(A) Face shields shall accommodate any of the following styles;

(i) Clear transparent.

(ii) Colored transparent.

(B) Disinfection. When a person is assigned protective equipment, it is recommended that this equipment be cleaned and disinfected regularly.

(C) Face shields must be an integral part of the fire helmet and may be installed in a fixed position or hinged allowing adjustment of the shields.

(D) In the event breathing apparatus is being used which incorporates a face mask, the face mask will be considered an acceptable face shield.

(d) Goggles, flexible, or cushioned fitting. Goggles shall consist of a wholly flexible frame, forming a lens holder or a rigid frame with integral lens or lenses, having a separate, cushioned fitting surface on the full periphery of the facial contact area.

(A) Materials used shall be chemical-resistant, nontoxic, nonirritating and slow-burning.

(B) There shall be a positive means of support on the face, such as an adjustable headband of suitable material or other appropriate means of support to retain the frame comfortably and snugly in front of the eyes.

(e) Design, construction, testing, and use of devices for eye and face protection shall be in accordance with ANSI Z87.1, Occupational Eye and Face Protection (1979).

NOTE: Fire fighters shall be protected from the effects of noise exposures which exceed the noise levels deemed to be safe as provided in OAR 437, Division 2/G, 1910.95, Occupational Noise Exposure.

(17) Requirements for Respiratory Protection. See OAR 437, Division 2/I, 1910.134, Respiratory Protection.

(18) Criteria for Approved Self-Contained Breathing Apparatus.

(a) Approved self-contained compressed air breathing apparatus may be used with approved cylinders from other approved self-contained compressed air breathing apparatus provided that such cylinders are of the same capacity and pressure rating. All compressed air cylinders used with self-contained breathing apparatus shall meet DOT and NIOSH criteria.

(b) Self-contained breathing apparatus shall be provided with an indicator which automatically sounds an audible alarm when the remaining air supply of the apparatus is reduced to within a range of 20 to 25 percent of its rated service time.

(19) (Reserved)

(20) Personal Alert Safety System (PASS). *Each member involved in rescue, fire suppression, or other hazardous duties after January 1, 2000, shall be provided with and shall use a PASS device in the hazardous area when self-contained breathing apparatus is in use. PASS devices shall meet the requirements of NFPA 1982, Standard on Personal Alert Safety Systems for Fire Fighters.*

Each PASS device shall be tested at least monthly and shall be maintained in accordance with the manufacturer's instructions.

(21) (Reserved)

(22) (Reserved)

(23) (Reserved)

(24) Breathing Air Compressors and Cylinders. *In addition to the requirements contained in 1910.134(i), air samples shall be taken every 6 months from the compressor and analyzed by the employer or an independent laboratory for Grade D breathing air. Air samples shall also be tested when the system is installed or repaired. Analysis shall be conducted according to ANSI/CGA Standard G7.1-1989 edition, Commodity Specification for Air.*

(25) Identification of Hazardous Material Locations.

(a) A means shall be provided for identifying nonresidential premises where hazardous materials are stored, as defined in the Uniform Fire Code, 1991 edition, as amended by the State of Oregon, effective July 15, 1992, under Articles 4 and 80, and in quantities as set forth in the hazardous material permit required by Article 4 of the Uniform Fire Code.

(b) Hazardous chemicals required to be identified by this section are those defined in Article 9, Section 9.110, and Article 80, Section 80.101 of the Uniform Fire Code.

(26) Hazardous Material Response Plan.

(a) Fire department that expects to or plans to respond to hazardous material incidents shall develop a written response plan.

(b) The written response plan must contain the policies and procedures on:

- (A) Pre-emergency planning and coordination with outside parties,*
- (B) Personnel roles, lines of authority, training, and communication,*
- (C) Emergency recognition and prevention,*
- (D) Safe distances,*
- (E) Scene security and control,*
- (F) Evacuation procedures,*
- (G) Decontamination,*
- (H) Emergency medical treatment and first aid,*
- (I) Personnel withdrawal procedures,*
- (J) Critique of response and follow-up,*
- (K) Personal protective equipment and emergency equipment and response procedures.*

(c) The incident commander shall be responsible for:

- (A) Identification of the hazardous substance and condition,*
- (B) Implementing emergency operations,*
- (C) Ensuring personal protective equipment is worn,*
- (D) Limit access to hot zone to those with a specific mission assignment,*
- (E) Implementing decontamination procedures,*
- (F) Designating a safety officer,*

- (G) Using appropriately trained personnel,*
- (H) On scene medical surveillance for emergency responders.*

FIRE FIGHTING APPARATUS

(27) Fire Apparatus Area.

- (a) Walkways around apparatus shall be kept free of obstructions.*
- (b) The station's apparatus floors shall be so far as practical kept free of grease, oil, and tripping hazards.*
- (c) No Class I or II flammable liquids shall be used for cleaning purposes to remove grease or dirt from apparatus.*
- (d) Exhaust gases from diesel or gasoline apparatus within buildings shall be maintained within the limits of OAR 437, Division 2/Z, OAR 437-002-0382, Oregon Air Contaminant Rules.*

(28) Design and Construction of Fire Apparatus.

- (a) All fire apparatus with the exception of specialized apparatus shall conform to OAR 437, Division 2/N, Oregon Rules for Commercial and Industrial Vehicles, OAR 437-002-0223.*
- (b) Employers who have purchased used fire apparatus or used military equipment prior to the effective date of this division shall not be required to bring them under a more stringent code than the one in force at the time the apparatus was manufactured. The exception to this rule would be seat belts and communication systems between the tailboard and driver compartment as required by OAR 437-002-0182(29) (Automotive Fire Apparatus Equipment) and roll bars on all open top off-road vehicles as required by OAR 437-002-0182(28)(f).*
- (c) Fire fighters' vehicle tailboards shall not project outboard of the vehicle sides or fenders and shall be designed to provide safe footing.*
- (d) Exhaust systems shall be installed and maintained in proper condition and shall be so designed as to minimize the exposure of the fire fighter to the exhaust gases.*
- (e) The loaded gross weight and empty height of the vehicle shall be posted in the vehicle such that it can be clearly read by the driver.*
- (f) Roll bars shall be in place on all open top off-road vehicles for rollover protection.*

(29) Automotive Fire Apparatus Equipment.

- (a) All equipment on a vehicle shall be adequately secured when the vehicle is in motion.*
- (b) Workers being transported by fire department vehicles shall ride only in designated secure positions. Safety restraints shall be provided for fire fighters riding the tailboard. (See also OAR 437, Division 2/N, Oregon Rules for Commercial and Industrial Vehicles, OAR 437-002-0223.)*
- (c) Vehicles with obstructed view to the rear of the vehicle when backing, shall be equipped with:
 - (A) An automatic back-up alarm which shall be sounded immediately on backing; or*
 - (B) A fire fighter, who is visible in the driver's left-side mirror, shall stand to the rear of the truck to guide the driver while backing.**
- (d) Fire fighting vehicles shall be brought to a full stop before workers disembark.*
- (e) If workers are required to ride the tailboard, an electrical signal system or voice communication system shall be installed between the tailboard and the driver's compartment. A code of signals shall be used for controlling the movement of the vehicle.*
- (f) When traffic flow is inhibited or encroachment of the traffic lane occurs, vehicles equipped with emergency warning lights shall be used to control traffic at emergency scenes. The use of traffic cones, fire department personnel, police, or other traffic control measures shall be used as soon as practical.*

(30) Automotive Apparatus Maintenance and Repair. Each employer shall establish written records and procedures whereby apparatus has:

- (a) A scheduled monthly maintenance check; or*
- (b) A maintenance check each time the apparatus is returned to the station following an emergency response, a drill, or any type of test drive.*

(31) Tires. Tires which are excessively worn, cracked, deteriorated or damaged in any way shall not be used. All tires shall have a minimum tread depth of 2/32-inch.

(32) Aerial Devices.

- (a) Aerial devices used for fire fighting shall be inspected and tested by a person competent in performing such tests and inspections in accordance with the recommendations of NFPA Standard 1914, 1991 edition, at least annually.*

(b) Where defects are found in critical components of an aerial device, the repairs shall be tested and certified in accordance with NFPA Standard 1914, 1991 edition, by a registered professional engineer or manufacturer of the apparatus or an American Welding Society (AWS) Certified Welding Inspector. A permanent record of such tests and repairs shall be maintained for each unit.

HOSE DRYING AND DRILL TOWERS

(33) Hose Drying Towers.

(a) Floor openings on hose tower platforms shall be equipped with a guardrail meeting the requirements of OAR 437, Division 2/D, 1910.23, Guarding Floor and Wall Openings and Holes.

(b) The toeboard requirements for elevated work platforms in hose drying towers shall not apply unless hand tools or objects other than hoses are carried onto the platforms.

(c) The requirements for ladders shall meet the requirements of OAR 437, Division 2/D, 437-002-0027, Fixed Ladders.

(d) Ropes used to hoist hose in the hose towers shall have a breaking strength to safe load strength (rated working load) ratio of 3 to 1.

(34) Drill Towers. Permanent fixed ladders on the outside of drill towers and drill buildings are exempt from the requirements of offset platform landings and ladder cage guards.

FIRE SERVICE EQUIPMENT

(35) Testing, Maintenance and Inspection of Fire Service Equipment. The employer shall maintain and inspect fire service equipment at least annually and perform any tests recommended by the manufacturers at the date of manufacture, or the recommendations of NFPA or IFSTA.

Stat. Auth.: ORS 654.025(2) and 656.726(4).

Stats. Implemented: ORS 654.001 through 654.295.

Hist: OR-OSHA Admin. Order 14-1993, f. 8/27/93, ef. 11/1/93.
OR-OSHA Admin. Order 2-1998, f. 3/11/98, ef. 3/11/98.
OR-OSHA Admin. Order 2-2000, f. 1/28/00, ef. 1/28/00.
OR-OSHA Admin. Order 12-2001, f. 10/26/01, ef. 10/26/01.
OR-OSHA Admin. Order 3-2005, f. 6/10/05, ef. 6/10/05.

Appendix A – Protective Apparel and Respirators (Nonmandatory)

This appendix is for the code user's information; it is not mandatory.

1. Protective clothing.

(A) General. OAR 437-002-0182(11) does not require all fire fighters to wear protective clothing. It is not the intention of these rules to require employers to provide a full ensemble of protective clothing for every fire fighter without consideration given to the types of hazardous environments to which the fire fighter might be exposed. It is the intention of these rules to require adequate protection for those fire fighters who might be exposed to fires in an advanced state, smoke, toxic gases, and high temperatures. Therefore, the protective clothing requirements only apply to those fire fighters who perform structural fire fighting operation.

- 2. Additionally, the protective clothing requirements do not apply to the protective clothing worn during outside fire fighting operations (brush and forest fires, crash crew operations) or other special fire fighting activities. It is important that the protective clothing to be worn during these types of fire fighting operations reflect the hazards which are expected to be encountered by fire fighters.*
- 3. Head protective devices are required to be provided with ear flaps so that the ear flaps will be available if need. It is recommended that ear protection always be used while fighting interior structural fires.*
- 4. Many head protective devices are equipped with face shields to protect the eyes and face. These face shields are permissible as meeting the eye and face protection requirements of this rule as long as such face shields meet the requirements of OAR 437, Division 2/I, Personal Protective Equipment and ANSI Z87.1-1968, Eye and Face Protection.*
- 5. Additionally, full facepieces, helmets or hoods of approved breathing apparatus which meet the requirements of OAR 437, Division 2/I, 1910.134, Respiratory Protection, and 437-002-0182 (11), (12), and (16), are also acceptable as meeting the eye and face protection requirements.*
- 6. It is recommended that protective clothing be thoroughly cleaned or washed each 6 months or as needed, following the recommendations of the clothing manufacturer and the cleaning requirements of NFPA Standard 1500 and 1571, 1996 editions.*
- 7. Respiratory protective devices. See OAR 437, Division 2/I, 1910.134, Respiratory Protection.*

Stat. Auth.: ORS 654.025(2) and 656.726(4).

Stats. Implemented: ORS 654.001 through 654.295.

Hist: OR-OSHA Admin. Order 14-1993, f. 8/27/93, ef. 11/1/93.
OR-OSHA Admin. Order 2-1998, f. 3/11/98, ef. 3/11/98.
OR-OSHA Admin. Order 2-2000, f. 1/28/00, ef. 1/28/00.

L

Appendix B – Apparatus Operation Signal Communication (Nonmandatory)

This is not a mandatory appendix. The signal system described here is only an example.

The following set of signals could be used for communication between the driver and a tiller or between the driver and fire fighters riding the tailboard:

- (a) One long buzz means “Stop.”***
- (b) Two buzzes means “Forward.”***
- (c) Three buzzes means “Reverse.”***

Before any of the above functions are undertaken, with the exception of stopping, the same appropriate signal must be received from the tailboard. Example: If driver is responding to an alarm before starting out, two beeps is responding to an alarm before starting out, two beeps on the horn will be sounded. Driver will not advance, however, until the same signal is sounded from the tailboard or tiller.

Stat. Auth.: ORS 654.025(2) and 656.726(4).

Stats. Implemented: ORS 654.001 through 654.295.

Hist: WCD Admin. Order, Safety 11-1985, f. 7/10/85, ef. 10/1/85.
OR-OSHA Admin. Order 14-1993, f. 8/27/93, ef. 11/1/93.

L

Appendix C – Minimum Requirements for Live Fire Training
This is a mandatory appendix as required by OAR 437-002-0182(10)(c).

The following requirements must be met prior to live fire training:

Training:

___ *All personnel are trained to the requirements of DPSST Entry level firefighter or the educational requirements of the assigned position;*

or

___ *Participants who have received training from another department or jurisdiction have provided written documentation that they meet the requirements of DPSST.*

___ *Instructors are adequately trained to appropriately perform their tasks.*

Pre-Burn planning for acquired structure:

A written plan:

___ *Is prepared by the Chief, or their designee.*

___ *Will be maintained and available for review by Oregon OSHA until the next live-fire training exercise.*

___ *A pre-burn briefing has been conducted with all personnel involved in the exercise including:*

___ *A walk through of the structure, with an emphasis on exits.*

___ *A discussion of the evacuation plan, including any signals for evacuation.*

___ *Methods of communication i.e., radio channels.*

___ *Where to locate medical treatment, rehabilitation, and the safety officer or Incident Command (IC).*

___ *Any limitations of the exercise or hazards that cannot be removed, but are protected.*

___ *Personal protective equipment that is required.*

___ *Personal protective equipment that is available (must include all required PPE).*

___ *Adequate first aid treatment is available for injuries.*

___ *No personnel will be allowed to simulate a victim in live fire exercises.*

___ *No fire will be set that will intentionally block an exit.*

L FIRE PROTECTION

- ___ Adequate food and fluids is available, as well as protection from extreme weather conditions.
- ___ *Acquired Structures:*
 - ___ Remove or contain all hazardous materials.
 - ___ Remove combustible material not intended for use in the training.
 - ___ Remove oil tanks or similar containers, or protect them from exploding or becoming over-pressurized.
 - ___ Only one fire is allowed inside a structure at a time.
 - ___ Remove or repair hazardous structural conditions to not pose a hazard to personnel.
 - ___ Disconnect all utilities to the training structure.
 - ___ Remove or protect utilities adjacent to the training structure prior to live fire training.
 - ___ Remove extraordinary weight overhead and/or debris in the training area that poses a hazard to personnel.
 - ___ Protect or remove adjacent buildings and/or property.
 - ___ All forms of asbestos have been addressed as per Division 2, Subdivision Z, OAR 1910.1001.
 - ___ Remove all environmental hazards, such as toxic weeds, insects, or vermin that could pose a hazard to personnel.
 - ___ Remove vegetation that poses a threat.
 - ___ Personnel exposed to on-road vehicle traffic will wear highly visible upper body garments that comply with OAR 437-002-0128.
 - ___ An inspection has been made by the Chief or their designee prior to the live fire exercise to ensure the provisions of this and all applicable standards are met.
- ___ *Permanent Burn Structures:*
 - ___ Buildings used for training burns have been visually inspected by a qualified person prior to training activities.
 - ___ Any damage that poses a hazard has been corrected.
 - ___ All equipment used in live fire training buildings has been inspected, and repaired if necessary, prior to use.

- ___ *All equipment is operated by a qualified person.*
- ___ *A designated parking area is established for apparatus not used in the training.*
- ___ *Follow traffic control requirements of OAR 437-002-0223(23)(c) if personnel are exposed to on-road vehicle traffic.*
- ___ *Keep persons not directly involved with the training behind designated fire lines.*
- ___ **Exterior Props:**
 - ___ *Areas around props are free of obstructions or vegetation that pose a hazard.*
 - ___ *Props have been visually inspected by the Chief or their designee prior to the live fire exercise.*
 - ___ *Defects have been repaired prior to use.*
- ___ **Vehicles used for live fire training:**
 - ___ *All containers on or in the vehicle that contain flammables, oxidizers, or other gases are emptied or ventilated to prevent explosion or unexpected burning.*
 - ___ *All batteries are removed.*
 - ___ *Equipment and material is secured to prevent unexpected movement.*
 - ___ *All split rims have been removed prior to ignition.*
- ___ **Water Supply:**
 - ___ *The Chief or their designee has documented the minimum water supply necessary based on the criteria identified in NFPA 1142 Standard on Water Supplies, 2001 edition.*
 - ___ *A reserve of 50 percent of the documented fire flow is available to protect surrounding structures.*
 - ___ *Separate sources of water will be maintained for attack lines and backup lines.*
 - ___ *Hydrants that will supply backup lines are identified and gated.*
 - ___ *Areas around the structure will be maintained clear of non essential equipment or personnel to allow for ease of deployment of hose lines.*
- ___ **Fuels:**
 - ___ *Use only fuels with known burning characteristics that are readily identifiable.*
 - ___ *Maintain fuel load at a level that is controllable and readily predictable.*

L FIRE PROTECTION

- ___ *Do not use flammable or combustible liquids unless the structure has been specifically designed to use those liquids as fuel.*
- ___ *The Chief or their designee has certified the fuel load and any factors that would affect growth, development, or spread of fire in each room of the structure being burned prior to live fire evolutions.*
- ___ *Immediately halt training if any hazard is noted.*
- Ignition Sources:**
- ___ *Use matches, fusees, or a drip torch to ignite an acquired structure.*
- ___ *Use matches, fusees, a drip torch, or flammable gas to ignite a permanent burn structure.*
- ___ *Other ignition/fuel sources (with known characteristics) are used only for arson investigation and fire-cause determination training when:*
 - ___ *The attack and back-up plans take into consideration the ignition/fuel source in providing for continued safety of all personnel.*
 - ___ *Live fire training activities are limited to back-up, control, and extinguishing the fire.*
- Incident Command Station (ICS):**
- ___ *Establish and maintain an ICS in accordance with OAR 437-002-0182(8).*
- ___ *Establish and maintain accountability in accordance with OAR 437-002-0182(9).*
- ___ *Establish and maintain a safety officer, independent from the IC (and not given other assignments) until the training is concluded.*
- ___ *Authorize the safety officer to halt the exercise at any time and for any reason.*
- ___ *Investigate all injuries by the Chief or their designee.*
- ___ *Halt training in cases of extreme weather.*
- ___ *Adequately train the safety officer for the position.*
- ___ *The safety officer may assign additional personnel in and around the structure to ensure the safety of personnel.*
- ___ *Only one ignition officer is designated who reports directly to the safety officer.*
- ___ *The ignition officer has a charged hose line when igniting the structure.*
- ___ *Ignition takes place under the direct supervision of the safety officer.*

Personal Protective Equipment:

- ___ *Appropriate PPE, in accordance with OAR 437-002-0182, is worn by all participants, including instructors.*

- ___ *Inspect all PPE for proper fit and maintenance prior to entering the structure.*

- ___ *Wear SCBA in accordance to OAR Division 2, Subdivision I, 1910.134.*

- ___ *Use hearing protection in accordance with OAR Division 2, Subdivision G, 1910.95.*

Stat. Auth.: ORS 654.025(2) and 656.726(4).

Stats. Implemented: ORS 654.001 through 654.295.

Hist: OR-OSHA Admin. Order 3-2005, f. 6/10/05, ef. 6/10/05.

L

SUBDIVISION L

FIRE PROTECTION

Authority: Secs. 4, 6, and 8, of the Occupational Safety and Health Act of 1970 (29 U.S.C. 653, 655, 657); Secretary of Labor's Order Nos. 12-71 (36 FR 8754), 8-76 (41 FR 25059), 9-83 (48 FR 35736), or 6-96 (62 FR 111), as applicable; 29 CFR part 1911.

§1910.155 Scope, Application and Definitions Applicable to This Subdivision.

(a) Scope. This subpart contains requirements for fire brigades, and all portable and fixed fire suppression equipment, fire detection systems, and fire or employee alarm systems installed to meet the fire protection requirements of 29 CFR Part 1910.

(b) Application. This subpart applies to all employments except for maritime, construction, and agriculture.

(c) Definitions applicable to this subpart.

(1) Afterflame means the time a test specimen continues to flame after the flame source has been removed.

(2) Aqueous film forming foam (AFFF) means a fluorinated surfactant with a foam stabilizer which is diluted with water to act as a temporary barrier to exclude air from mixing with the fuel vapor by developing an aqueous film on the fuel surface of some hydrocarbons which is capable of suppressing the generation of fuel vapors.

(3) Approved means acceptable to the Assistant Secretary under the following criteria:

(i) If it is accepted, or certified, or listed, or labeled or otherwise determined to be safe by a nationally recognized testing laboratory; or

(ii) With respect to an installation or equipment of a kind which no nationally recognized testing laboratory accepts, certifies, lists, labels, or determines to be safe, if it is inspected or tested by another Federal agency and found in compliance with the provisions of the applicable National Fire Protection Association Fire Code; or

(iii) With respect to custom-made equipment or related installations which are designed, fabricated for, and intended for use by its manufacturer on the basis of test data which the employer keeps and makes available for inspection to the Assistant Secretary.

(iv) For the purposes of paragraph (c)(3) of this section:

- (A) Equipment is listed if it is of a kind mentioned in a list which is published by a nationally recognized testing laboratory which makes periodic inspections of the production of such equipment and which states that such equipment meets nationally recognized standards or has been tested and found safe for use in a specified manner;
- (B) Equipment is labeled if there is attached to it a label, symbol, or other identifying mark of a nationally recognized testing laboratory which makes periodic inspections of the production of such equipment, and whose labeling indicates compliance with nationally recognized standards or tests to determine safe use in a specified manner;
- (C) Equipment is accepted if it has been inspected and found by a nationally recognized testing laboratory to conform to specified plans or to procedures of applicable codes; and
- (D) Equipment is certified if it has been tested and found by a nationally recognized testing laboratory to meet nationally recognized standards or to be safe for use in a specified manner or is of a kind whose production is periodically inspected by a nationally recognized testing laboratory, and if it bears a label, tag, or other record of certification.
- (E) Refer to §1910.7 for definition of nationally recognized testing laboratory.
- (4) **Assistant Secretary** means the Assistant Secretary of Labor for Occupational Safety and Health or designee.
- (5) **Automatic fire detection device** means a device designed to automatically detect the presence of fire by heat, flame, light, smoke or other products of combustion.
- (6) **Buddy-breathing device** means an accessory to self-contained breathing apparatus which permits a second person to share the same air supply as that of the wearer of the apparatus.
- (7) **Carbon dioxide** means a colorless, odorless, electrically nonconductive inert gas (chemical formula CO₂) that is a medium for extinguishing fires by reducing the concentration of oxygen or fuel vapor in the air to the point where combustion is impossible.
- (8) **Class A fire** means a fire involving ordinary combustible materials such as paper, wood, cloth, and some rubber and plastic materials.
- (9) **Class B fire** means a fire involving flammable or combustible liquids, flammable gases, greases and similar materials, and some rubber and plastic materials.
- (10) **Class C fire** means a fire involving energized electrical equipment where safety to the employee requires the use of electrically nonconductive extinguishing media.

(11) Class D fire means a fire involving combustible metals such as magnesium, titanium, zirconium, sodium, lithium and potassium.

(12) Dry chemical means an extinguishing agent composed of very small particles of chemicals such as, but not limited to, sodium bicarbonate, potassium bicarbonate, urea-based potassium bicarbonate, potassium chloride, or monoammonium phosphate supplemented by special treatment to provide resistance to packing and moisture absorption (caking) as well as to provide proper flow capabilities. Dry chemical does not include dry powders.

(13) Dry powder means an compound used to extinguish or control Class D fires.

(14) Education means the process of imparting knowledge or skill through systematic instruction. It does not require formal classroom instruction.

(15) Enclosed structure means a structure with a roof or ceiling and at least two walls which may present fire hazards to employees, such as accumulations of smoke, toxic gases and heat, similar to those found in buildings.

(16) Extinguisher classification means the letter classification given an extinguisher to designate the class or classes of fire on which an extinguisher will be effective.

(17) Extinguisher rating means the numerical rating given to an extinguisher which indicates the extinguishing potential of the unit based on standardized tests developed by Underwriters' Laboratories, Inc.

(18) Fire brigade (private fire department, industrial fire department) means an organized group of employees who are knowledgeable, trained, and skilled in at least basic fire fighting operations.

(19) Fixed extinguishing system means a permanently installed system that either extinguishes or controls a fire at the location of the system.

(20) Flame-resistance is the property of materials, or combinations of component materials, to retard ignition and restrict the spread of flame.

(21) Foam means a stable aggregation of small bubbles which flow freely over a burning liquid surface and form a coherent blanket which seals combustible vapors and thereby extinguishes the fire.

(22) Gaseous agent is a fire extinguishing agent which is in the gaseous state at normal room temperature and pressure. It has low viscosity, can expand or contract with changes in pressure and temperature, and has the ability to diffuse readily and to distribute itself uniformly throughout an enclosure.

(23) Halon 1211 means a colorless, faintly sweet smelling, electrically nonconductive liquefied gas (chemical formula CBrClF_2) which is a medium for extinguishing fires by inhibiting the chemical chain reaction of fuel and oxygen. It is also known as bromochlorodifluoromethane.

(24) Halon 1301 means a colorless, odorless, electrically nonconductive gas (chemical formula CBrF_3) which is a medium for extinguishing fires by inhibiting the chemical chain reaction of fuel and oxygen. It is also known as bromotrifluoromethane.

(25) Helmet is a head protective device consisting of a rigid shell, energy absorption system, and chin strap intended to be worn to provide protection for the head or portions thereof, against impact, flying or falling objects, electric shock, penetration, heat and flame.

(26) Incipient stage fire means a fire which is in the initial or beginning stage and which can be controlled or extinguished by portable fire extinguishers, Class II standpipe or small hose systems without the need for protective clothing or breathing apparatus.

(27) Inspection means a visual check of fire protection systems and equipment to ensure that they are in place, charged, and ready for use in the event of a fire.

(28) Interior structural fire fighting means the physical activity of fire suppression, rescue or both, inside of buildings or enclosed structures which are involved in a fire situation beyond the incipient stage.

(29) Lining means a material permanently attached to the inside of the outer shell of a garment for the purpose of thermal protection and padding.

(30) Local application system means a fixed fire suppression system which has a supply of extinguishing agent, with nozzles arranged to automatically discharge extinguishing agent directly on the burning material to extinguish or control a fire.

(31) Maintenance means the performance of services on fire protection equipment and systems to assure that they will perform as expected in the event of a fire. Maintenance differs from inspection in that maintenance requires the checking of internal fittings, devices and agent supplies.

(32) Multipurpose dry chemical means a dry chemical which is approved for use on Class A, Class B and Class C fires.

(33) Outer shell is the exterior layer of material on the fire coat and protective trousers which forms the outermost barrier between the fire fighter and the environment. It is attached to the vapor barrier and liner and is usually constructed with a storm flap, suitable closures, and pockets.

(34) Positive-pressure breathing apparatus means self-contained breathing apparatus in which the pressure in the breathing zone is positive in relation to the immediate environment during inhalation and exhalation.

(35) Predischage employee alarm means an alarm which will sound at a set time prior to actual discharge of an extinguishing system so that employees may evacuate the discharge area prior to system discharge.

(36) Quick disconnect valve means a device which starts the flow of air by inserting of the hose (which leads from the facepiece) into the regulator of self-contained breathing apparatus, and stops the flow of air by disconnection of the hose from the regulator.

(37) Sprinkler alarm means an approved device installed so that any waterflow from a sprinkler system equal to or greater than that from single automatic sprinkler will result in an audible alarm signal on the premises.

(38) Sprinkler system means a system of piping designed in accordance with fire protection engineering standards and installed to control or extinguish fires. The system includes an adequate and reliable water supply, and a network of specially sized piping and sprinklers which are interconnected. The system also includes a control valve and a device for actuating an alarm when the system is in operation.

(39) Standpipe systems.

(i) Class I standpipe system means a 2 1/2-inch (6.3 cm) hose connection for use by fire departments and those trained in handling heavy fire streams.

(ii) Class II standpipe system means a 1 1/2-inch (3.8 cm) hose system which provides a means for the control or extinguishment of incipient stage fires.

(iii) Class III standpipe system means a combined system of hose which is for the use of employees trained in the use of hose operations and which is capable of furnishing effective water discharge during the more advanced stages of fire (beyond the incipient stage) in the interior of workplaces. Hose outlets are available for both 1 1/2-inch (3.8 cm) and 2 1/2-inch (6.3 cm) hose.

(iv) Small hose system means a system of hose ranging in diameter from 5/8-inch (1.6 cm) up to 1 1/2-inch (3.8 cm) which is for the use of employees and which provides a means for the control and extinguishment of incipient stage fires.

(40) Total flooding system means a fixed suppression system which is arranged to automatically discharge a predetermined concentration of agent into an enclosed space for the purpose of fire extinguishment or control.

(41) Training means the process of making proficient through instruction and hands-on practice in the operation of equipment, including respiratory protection equipment, that is expected to be used and in the performance of assigned duties.

(42) Vapor barrier means that material used to prevent or substantially inhibit the transfer of water, corrosive liquids and steam or other hot vapors from the outside of a garment to the wearer's body.

[45 FR 60704, Sept. 12, 1980, as amended at 53 FR 12122, Apr. 12, 1988]

Stat. Auth.: ORS 654.025(2) and 656.726(4).

Stats. Implemented: ORS 654.001 through 654.295.

Hist: OR-OSHA Admin. Order 14-1993, f. 8/27/93, ef. 11/1/93

L

§1910.156 Fire Brigades.

(a) Scope and application.

(1) Scope. This section contains requirements for the organization, training, and personal protective equipment of fire brigades whenever they are established by an employer.

(2) Application. The requirements of this section apply to fire brigades, industrial fire departments and private or contractual type fire departments. Personal protective equipment requirements apply only to members of fire brigades performing interior structural fire fighting. The requirements of this section do not apply to airport crash rescue or forest fire fighting operations.

(b) Organization.

(1) Organizational statement. The employer shall prepare and maintain a statement or written policy which establishes the existence of a fire brigade; the basic organizational structure; the type, amount, and frequency of training to be provided to fire brigade members; the expected number of members in the fire brigade; and the functions that the fire brigade is to perform at the workplace. The organizational statement shall be available for inspection by the Assistant Secretary and by employees or their designated representatives.

(2) Personnel. The employer shall assure that employees who are expected to do interior structural fire fighting are physically capable of performing duties which may be assigned to them during emergencies. The employer shall not permit employees with known heart disease, epilepsy, or emphysema, to participate in fire brigade emergency activities unless a physician's certificate of the employees' fitness to participate in such activities is provided. For employees assigned to fire brigades before September 15, 1980, this paragraph is effective on September 15, 1990. For employees assigned to fire brigades on or after September 15, 1980, this paragraph is effective December 15, 1980.

(c) Training and education.

(1) The employer shall provide training and education for all fire brigade members commensurate with those duties and functions that fire brigade members are expected to perform. Such training and education shall be provided to fire brigade members before they perform fire brigade emergency activities. Fire brigade leaders and training instructors shall be provided with training and education which is more comprehensive than that provided to the general membership of the fire brigade.

(2) The employer shall assure that training and education is conducted frequently enough to assure that each member of the fire brigade is able to perform the member's assigned duties and functions satisfactorily and in a safe manner so as not to endanger fire brigade members or other employees. All fire brigade members shall be provided with training at least annually. In addition, fire brigade members who are expected to perform interior structural fire fighting shall be provided with an education session or training at least quarterly.

(3) The quality of the training and education program for fire brigade members shall be similar to those conducted by such fire training schools as the Maryland Fire and Rescue Institute; Iowa Fire Service Extension; West Virginia Fire Service Extension; Georgia Fire Academy, New York State Department, Fire Prevention and Control; Louisiana State University Firemen Training Program, or Washington State's Fire Service Training Commission for Vocational Education. (For example, for the oil refinery industry, with its unique hazards, the training and education program for those fire brigade members shall be similar to those conducted by Texas A & M University, Lamar University, Reno Fire School, or the Delaware State Fire School.)

(4) The employer shall inform fire brigade members about special hazards such as storage and use of flammable liquids and gases, toxic chemicals, radioactive sources, and water reactive substances, to which they may be exposed during fire and other emergencies. The fire brigade members shall also be advised of any changes that occur in relation to the special hazards. The employer shall develop and make available for inspection by fire brigade members, written procedures that describe the actions to be taken in situations involving the special hazards and shall include these in the training and education program.

(d) Fire fighting equipment. The employer shall maintain and inspect, at least annually, fire fighting equipment to assure the safe operational condition of the equipment. Portable fire extinguishers and respirators shall be inspected at least monthly. Fire fighting equipment that is in damaged or unserviceable condition shall be removed from service and replaced.

(e) Protective clothing. The following requirements apply to those employees who perform interior structural fire fighting. The requirements do not apply to employees who use fire extinguishers or standpipe systems to control or extinguish fires only in the incipient stage.

(1) General.

(i) The employer shall provide at no cost to the employee and assure the use of protective clothing which complies with the requirements of this paragraph. The employer shall assure that protective clothing ordered or purchased after July 1, 1981, meets the requirements contained in this paragraph. As the new equipment is provided, the employer shall assure that all fire brigade members wear the equipment when performing interior structural fire fighting. After July 1, 1985, the employer shall assure that all fire brigade members wear protective clothing meeting the requirements of this paragraph when performing interior structural fire fighting.

(ii) The employer shall assure that protective clothing protects the head, body, and extremities, and consists of at least the following components: foot and leg protection; hand protection; body protection; eye, face and head protection.

(2) Foot and leg protection.

(i) Foot and leg protection shall meet the requirements of paragraphs (e)(2)(ii) and (e)(2)(iii) of this section, and may be achieved by either of the following methods:

(A) Fully extended boots which provide protection for the legs; or

(B) Protective shoes or boots worn in combination with protective trousers that meet the requirements of paragraph (e)(3) of this section.

(ii) Protective footwear shall meet the requirements of §1910.136 for Class 75 footwear. In addition, protective footwear shall be water-resistant for at least 5 inches (12.7 cm) above the bottom of the heel and shall be equipped with slip-resistant outer soles.

(iii) Protective footwear shall be tested in accordance with paragraph (1) of Appendix E, and shall provide protection against penetration of the midsole by a size 8D common nail when at least 300 pounds (1330 N) of static force is applied to the nail.

(3) Body protection.

(i) Body protection shall be coordinated with foot and leg protection to ensure full body protection for the wearer. This shall be achieved by one of the following methods:

(A) Wearing of a fire-resistive coat meeting the requirements of paragraph (e)(3)(ii) of this section in combination with fully extended boots meeting the requirements of paragraphs (e)(2)(ii) and (e)(2)(iii) of this section; or

(B) Wearing of a fire-resistive coat in combination with protective trousers both of which meet the requirements of paragraph (e)(3)(ii) of this section.

(ii) The performance, construction, and testing of fire-resistive coats and protective trousers shall be at least equivalent to the requirements of the National Fire Protection Association (NFPA) standard NFPA No. 1971-1975, "Protective Clothing for Structural Fire Fighting," which is incorporated by reference as specified in §1910.6, (See Appendix D to Subpart L) with the following permissible variations from those requirements:

(A) Tearing strength of the outer shell shall be a minimum of 8 pounds (35.6 N) in any direction when tested in accordance with paragraph (2) of Appendix E; and

(B) The outer shell may discolor but shall not separate or melt when placed in a forced air laboratory oven at a temperature of 500 degrees F (260 degrees C) for a period of 5 minutes. After cooling to ambient temperature and using the test method specified in paragraph (3) of Appendix E, char length shall not exceed 4.0 inches (10.2 cm) and afterflame shall not exceed 2.0 seconds.

(4) Hand protection.

(i) Hand protection shall consist of protective gloves or glove system which will provide protection against cut, puncture, and heat penetration. Gloves or glove system shall be tested in accordance with the test methods contained in the National Institute for Occupational Safety and Health (NIOSH) 1976 publication, "The Development of Criteria for Fire Fighter's Gloves; Vol. II, Part II: Test Methods," which is incorporated by reference as specified in §1910.6, (See Appendix D to Subpart L) and shall meet the following criteria for cut, puncture, and heat penetration:

(A) Materials used for gloves shall resist surface cut by a blade with an edge having a 60 degrees included angle and a .001-inch (.0025 cm.) radius, under an applied force of 16 lbf (72N), and at a slicing velocity of greater or equal to 60 in/min (2.5 cm./sec);

(B) Materials used for the palm and palm side of the fingers shall resist puncture by a penetrometer (simulating a 4d lath nail), under an applied force of 13.2 lbf (60N), and at a velocity greater or equal to 20 in/min (.85 cm./sec); and

(C) The temperature inside the palm and gripping surface of the fingers of gloves shall not exceed 135 degrees F (57 degrees C) when gloves or glove system are exposed to 932 degrees F (500 degrees C) for 5 seconds at 4 psi (28 kPa) pressure.

(ii) Exterior materials of gloves shall be flame-resistant and shall be tested in accordance with paragraph (3) of Appendix E. Maximum allowable afterflame shall be 2.0 seconds, and the maximum char length shall be 4.0 inches (10.2 cm).

(iii) When design of the fire-resistive coat does not otherwise provide protection for the wrists, protective gloves shall have wristlets of at least 4.0 inches (10.2 cm) in length to protect the wrist area when the arms are extended upward and outward from the body.

(5) Head, eye and face protection.

(i) Head protection shall consist of a protective head device with ear flaps and chin strap which meet the performance, construction, and testing requirements of the National Fire Safety and Research Office of the National Fire Prevention and Control Administration, U.S. Department of Commerce (now known as the U.S. Fire Administration), which are contained in "Model Performance Criteria for Structural Firefighters' Helmets" (August 1977) which is incorporated by reference as specified in §1910.6 (See Appendix D to Subpart L).

(ii) Protective eye and face devices which comply with §1910.133 shall be used by fire brigade members when performing operations where the hazards of flying or falling materials which may cause eye and face injuries are present. Protective eye and face devices provided as accessories to protective head devices (face shields) are permitted when such devices meet the requirements of §1910.133.

(iii) Full facepieces, helmets, or hoods of breathing apparatus which meet the requirements of §1910.134 and paragraph (f) of this section, shall be acceptable as meeting the eye and face protection requirements of paragraph (e)(5)(ii) of this section.

(f) Respiratory protection.

(1) General.

(i) The employer must ensure that respirators are provided to, and used by, fire brigade members, and that the respirators meet the requirements of 29 CFR 1910.134 and this paragraph.

(ii) Approved self-contained breathing apparatus with full-facepiece, or with approved helmet or hood configuration, shall be provided to and worn by fire brigade members while working inside buildings or confined spaces where toxic products of combustion or an oxygen deficiency may be present.

Such apparatus shall also be worn during emergency situations involving toxic substances.

(iii) Approved self-contained breathing apparatus may be equipped with either a "buddy-breathing" device or a quick disconnect valve, even if these devices are not certified by NIOSH. If these accessories are used, they shall not cause damage to the apparatus, or restrict the air flow of the apparatus, or obstruct the normal operation of the apparatus.

(iv) Approved self-contained compressed air breathing apparatus may be used with approved cylinders from other approved self-contained compressed air breathing apparatus provided that such cylinders are of the same capacity and pressure rating. All compressed air cylinders used with self-contained breathing apparatus shall meet DOT and NIOSH criteria.

(v) Self-contained breathing apparatuses must have a minimum service-life rating of 30 minutes in accordance with the methods and requirements specified by NIOSH, under 42 CFR part 84, except for escape self-contained breathing apparatus (ESCBAs) used only for emergency escape purposes.

(vi) Self-contained breathing apparatuses shall be provided with an indicator which automatically sounds an audible alarm when the remaining service life of the apparatus is reduced to within a range of 20 to 25 percent of its rated service time.

(2) Positive-pressure breathing apparatus.

(i) The employer shall assure that self-contained breathing apparatus ordered or purchased after July 1, 1981, for use by fire brigade members performing interior structural fire fighting operations, are of the pressure-demand or other positive-pressure type. Effective July 1, 1983, only pressure-demand or other positive-pressure self-contained breathing apparatus shall be worn by fire brigade members performing interior structural fire fighting.

(ii) This paragraph does not prohibit the use of a self-contained breathing apparatus where the apparatus can be switched from a demand to a positive-pressure mode. However, such apparatus shall be in the positive-pressure mode when fire brigade members are performing interior structural fire fighting operations.

(Approved by the Office of Management and Budget under control number 1218-0075)

[45 FR 60706, Sept. 12, 1980; 46 FR 24557, May 1, 1981; 49 FR 18295, Apr. 30, 1984]

Stat. Auth.: ORS 654.025(2) and 656.726(4).

Stat. Implemented: ORS 654.001 through 654.295.

Hist: OR-OSHA Admin. Order 14-1993, f. 8/27/93, ef. 11/1/93.

OR-OSHA Admin. Order 4-1997, f. 4/2/97, ef. 4/2/97.

OR-OSHA Admin. Order 3-1998, f. 7/7/98, ef. 7/7/98.

OR-OSHA Admin. Order 4-1999, f. 4/30/99, ef. 4/30/99.

Portable Fire Suppression Equipment

§1910.157 Portable Fire Extinguishers.

(a) Scope and application. The requirements of this section apply to the placement, use, maintenance, and testing of portable fire extinguishers provided for the use of employees. Paragraph (d) of this section does not apply to extinguishers provided for employee use on the outside of workplace buildings or structures. Where extinguishers are provided but are not intended for employee use and the employer has an emergency action plan and a fire prevention plan which meet the requirements of §1910.38, then only the requirements of paragraphs (e) and (f) of this section apply. *NOTE: 1910.38 is now 437-002-0042 and 0043.*

(b) Exemptions.

(1) Where the employer has established and implemented a written fire safety policy which requires the immediate and total evacuation of employees from the workplace upon the sounding of a fire alarm signal and which includes an emergency action plan and a fire prevention plan which meet the requirements of §1910.38, and when extinguishers are not available in the workplace, the employer is exempt from all requirements of this section unless a specific standard in Part 1910 requires that a portable fire extinguisher be provided. *NOTE: 1910.38 is now 437-002-0042 and 0043.*

(2) Where the employer has an emergency action plan meeting the requirements of §1910.38 which designates certain employees to be the only employees authorized to use the available portable fire extinguishers, and which requires all other employees in the fire area to immediately evacuate the affected work area upon the sounding of the fire alarm, the employer is exempt from the distribution requirements in paragraph (d) of this section. *NOTE: 1910.38 is now 437-002-0042 and 0043.*

(c) General requirements.

(1) The employer shall provide portable fire extinguishers and shall mount, locate and identify them so that they are readily accessible to employees without subjecting the employees to possible injury.

(2) Only approved portable fire extinguishers shall be used to meet the requirements of this section.

(3) The employer shall not provide or make available in the workplace portable fire extinguishers using carbon tetrachloride or chlorobromomethane extinguishing agents.

(4) The employer shall assure that portable fire extinguishers are maintained in a fully charged and operable condition and kept in their designated places at all times except during use.

(5) The employer shall remove from service all soldered or riveted shell self-generating soda acid or self-generating foam or gas cartridge water type portable fire extinguishers which are operated by inverting the extinguisher to rupture the cartridge or to initiate an uncontrollable pressure generating chemical reaction to expel the agent.

(d) Selection and distribution.

- (1)** Portable fire extinguishers shall be provided for employee use and selected and distributed based on the classes of anticipated workplace fires and on the size and degree of hazard which would affect their use.
- (2)** The employer shall distribute portable fire extinguishers for use by employees on Class A fires so that the travel distance for employees to any extinguisher is 75 feet (22.9 m) or less.
- (3)** The employer may use uniformly spaced standpipe systems or hose stations connected to a sprinkler system installed for emergency use by employees instead of Class A portable fire extinguishers, provided that such systems meet the respective requirements of §1910.158 or §1910.159, that they provide total coverage of the area to be protected, and that employees are trained at least annually in their use.
- (4)** The employer shall distribute portable fire extinguishers for use by employees on Class B fires so that the travel distance from the Class B hazard area to any extinguisher is 50 feet (15.2 m) or less.
- (5)** The employer shall distribute portable fire extinguishers used for Class C hazards on the basis of the appropriate pattern for the existing Class A or Class B hazards.
- (6)** The employer shall distribute portable fire extinguishers or other containers of Class D extinguishing agent for use by employees so that the travel distance from the combustible metal working area to any extinguishing agent is 75 feet (22.9 m) or less. Portable fire extinguishers for Class D hazards are required in those combustible metal working areas where combustible metal powders, flakes, shavings, or similarly sized products are generated at least once every 2 weeks.

(e) Inspection, maintenance and testing.

- (1)** The employer shall be responsible for the inspection, maintenance and testing of all portable fire extinguishers in the workplace.
- (2)** Portable extinguishers or hose used in lieu thereof under paragraph (d)(3) of this section shall be visually inspected monthly.
- (3)** The employer shall assure that portable fire extinguishers are subjected to an annual maintenance check. Stored pressure extinguishers do not require an internal examination. The employer shall record the annual maintenance date and retain this record for 1-year after the last entry or the life of the shell, whichever is less. The record shall be available to the Assistant Secretary upon request.
- (4)** The employer shall assure that stored pressure dry chemical extinguishers that require a 12-year hydrostatic test are emptied and subjected to applicable maintenance procedures every 6 years. Dry chemical extinguishers having nonrefillable disposable containers are exempt from this requirement. When recharging or hydrostatic testing is performed, the 6-year requirement begins from that date.

FIRE PROTECTION L

(5) The employer shall assure that alternate equivalent protection is provided when portable fire extinguishers are removed from service for maintenance and recharging.

(f) Hydrostatic testing.

(1) The employer shall assure that hydrostatic testing is performed by trained persons with suitable testing equipment and facilities.

(2) The employer shall assure that portable extinguishers are hydrostatically tested at the intervals listed in Table L-1 of this section, except under any of the following conditions:

(i) When the unit has been repaired by soldering, welding, brazing, or use of patching compounds;

(ii) When the cylinder or shell threads are damaged;

(iii) When there is corrosion that has caused pitting, including corrosion under removable name plate assemblies;

(iv) When the extinguisher has been burned in a fire; or

(v) When a calcium chloride extinguishing agent has been used in a stainless steel shell.

(3) In addition to an external visual examination, the employer shall assure that an internal examination of cylinders and shells to be tested is made prior to the hydrostatic tests.

Table L-1

| Type of extinguishers | Test interval (years) |
|-----------------------|-----------------------|
|-----------------------|-----------------------|

L FIRE PROTECTION

| | |
|--|-----------------------|
| Soda acid (soldered brass shells) (until 1/1/82)..... | (¹) 5 |
| Soda acid (stainless steel shell)..... | 5 |
| Cartridge operated water and/or antifreeze..... | 5 |
| Stored pressure water and/or antifreeze..... | (¹) 5 |
| Wetting agent..... | 5 |
| Foam (soldered brass shells) (until 1/1/82)..... | 5 |
| Foam (stainless steel shell)..... | 12 |
| Aqueous Film Forming foam (AFFF) | 12 |
| Loaded stream..... | 12 |
| Dry chemical with stainless steel..... | |
| Carbon dioxide..... | |
| Dry chemical, stored pressure, with mild steel, brazed brass or aluminum shells..... | |
| Dry chemical, cartridge or cylinder operated, with mild steel shells..... | |
| Halon 1211..... | |
| Halon 1301..... | |
| Dry powder, cartridge or cylinder operated with mild steel shells..... | |

¹ Extinguishers having shells constructed of copper or brass joined by soft solder or rivets shall not be hydrostatically tested and shall be removed from service by January 1, 1982. (Not permitted)

(4) The employer shall assure that portable fire extinguishers are hydrostatically tested whenever they show new evidence of corrosion or mechanical injury, except under the conditions listed in paragraphs (f)(2)(i) through (v) of this section.

FIRE PROTECTION L

- (5)** The employer shall assure that hydrostatic tests are performed on extinguisher hose assemblies which are equipped with a shutoff nozzle at the discharge end of the hose. The test interval shall be the same as specified for the extinguisher on which the hose is installed.
- (6)** The employer shall assure that carbon dioxide hose assemblies with a shutoff nozzle are hydrostatically tested at 1,250 psi (8,620 kPa).
- (7)** The employer shall assure that dry chemical and dry powder hose assemblies with a shutoff nozzle are hydrostatically tested at 300 psi (2,070 kPa).
- (8)** Hose assemblies passing a hydrostatic test do not require any type of recording or stamping.
- (9)** The employer shall assure that hose assemblies for carbon dioxide extinguishers that require a hydrostatic test are tested within a protective cage device.
- (10)** The employer shall assure that carbon dioxide extinguishers and nitrogen or carbon dioxide cylinders used with wheeled extinguishers are tested every 5 years at 5/3 of the service pressure as stamped into the cylinder. Nitrogen cylinders which comply with 49 CFR 173.34(e)(15) may be hydrostatically tested every 10 years.
- (11)** The employer shall assure that all stored pressure and Halon 1211 types of extinguishers are hydrostatically tested at the factory test pressure not to exceed two times the service pressure.
- (12)** The employer shall assure that acceptable self-generating type soda acid and foam extinguishers are tested at 350 psi (2,410 kPa).
- (13)** Air or gas pressure may not be used for hydrostatic testing.
- (14)** Extinguisher shells, cylinders, or cartridges which fail a hydrostatic pressure test, or which are not fit for testing shall be removed from service and from the workplace.
- (15)**
- (i)** The equipment for testing compressed gas type cylinders shall be of the water jacket type. The equipment shall be provided with an expansion indicator which operates with an accuracy within 1-percent of the total expansion or .1 cc (.1 mL) of liquid.
 - (ii)** The equipment for testing noncompressed gas type cylinders shall consist of the following:
 - (A)** A hydrostatic test pump, hand or power operated, capable of producing not less than 150 percent of the test pressure, which shall include appropriate check valves and fittings;

(B) A flexible connection for attachment to fittings to test through the extinguisher nozzle, test bonnet, or hose outlet, as is applicable; and

(C) A protective cage or barrier for personal protection of the tester, designed to provide visual observation of the extinguisher under test.

(16) The employer shall maintain and provide upon request to the Assistant Secretary evidence that the required hydrostatic testing of fire extinguishers has been performed at the time intervals shown in Table L-1. Such evidence shall be in the form of a certification record which includes the date of the test, the signature of the person who performed the test and the serial number, or other identifier, of the fire extinguisher that was tested. Such records shall be kept until the extinguisher is hydrostatically retested at the time interval specified in Table L-1 or until the extinguisher is taken out of service, whichever comes first.

(g) Training and education.

(1) Where the employer has provided portable fire extinguishers for employee use in the workplace, the employer shall also provide an educational program to familiarize employees with the general principles of fire extinguisher use and the hazards involved with incipient stage fire fighting.

(2) The employer shall provide the education required in paragraph (g)(1) of this section upon initial employment and at least annually thereafter.

(3) The employer shall provide employees who have been designated to use fire fighting equipment as part of an emergency action plan with training in the use of the appropriate equipment.

(4) The employer shall provide the training required in paragraph (g)(3) of this section upon initial assignment to the designated group of employees and at least annually thereafter.

[45 FR 60708, Sept. 12, 1980; 46 FR 24557, May 1, 1981, as amended at 51 FR 34560, Sept. 29, 1986]

Stat. Auth.: ORS 654.025(2) and 656.726(4).

Stats. Implemented: ORS 654.001 through 654.295.

Hist: OR-OSHA Admin. Order 14-1993, f. 8/27/93, ef. 11/1/93.

OR-OSHA Admin. Order 4-1997, f. 4/2/97, ef. 4/2/97.

OR-OSHA Admin. Order 12-2001, f. 10/26/01, ef. 10/26/01.

FIRE PROTECTION L

§1910.158 Standpipe and Hose Systems.

(a) Scope and application.

(1) **Scope.** This section applies to all small hose, Class II, and Class III standpipe systems installed to meet the requirements of a particular OSHA standard.

(2) **Exception.** This section does not apply to Class I standpipe systems.

(b) **Protection of standpipes.** The employer shall assure that standpipes are located or otherwise protected against mechanical damage. Damaged standpipes shall be repaired promptly.

(c) Equipment.

(1) **Reels and cabinets.** Where reels or cabinets are provided to contain fire hose, the employer shall assure that they are designed to facilitate prompt use of the hose valves, the hose, and other equipment at the time of a fire or other emergency. The employer shall assure that the reels and cabinets are conspicuously identified and used only for fire equipment.

(2) Hose outlets and connections.

(i) The employer shall assure that hose outlets and connections are located high enough above the floor to avoid being obstructed and to be accessible to employees.

(ii) The employer shall standardize screw threads or provide appropriate adapters throughout the system and assure that the hose connections are compatible with those used on the supporting fire equipment.

(3) Hose.

(i) The employer shall assure that every 1 1/2-inch (3.8 cm) or smaller hose outlet used to meet this standard is equipped with hose connected and ready for use. In extremely cold climates where such installation may result in damaged equipment, the hose may be stored in another location provided it is readily available and can be connected when needed.

(ii) Standpipe systems installed after January 1, 1981, for use by employees, shall be equipped with lined hose. Unlined hose may remain in use on existing systems. However, after the effective date of this standard, unlined hose which becomes unserviceable shall be replaced with lined hose.

(iii) The employer shall provide hose of such length that friction loss resulting from water flowing through the hose will not decrease the pressure at the nozzle below 30 psi (210 kPa). The dynamic pressure at the nozzle shall be within the range of 30 psi (210 kPa) to 125 psi (860 kPa).

(4) **Nozzles.** The employer shall assure that standpipe hose is equipped with shutoff type nozzles.

(d) Water supply. The minimum water supply for standpipe and hose systems, which are provided for the use of employees, shall be sufficient to provide 100 gallons per minute (6.3 l/s) for a period of at least 30 minutes.

(e) Tests and maintenance.

(1) Acceptance tests.

(i) The employer shall assure that the piping of Class II and Class III systems installed after January 1, 1981, including yard piping, is hydrostatically tested for a period of at least 2 hours at not less than 200 psi (1380 kPa), or at least 50 psi (340 kPa) in excess of normal pressure when such pressure is greater than 150 psi (1030 kPa).

(ii) The employer shall assure that hose on all standpipe systems installed after January 1, 1981, is hydrostatically tested with couplings in place, at a pressure of not less than 200 psi (1380 kPa), before it is placed in service. This pressure shall be maintained for at least 15 seconds and not more than 1-minute during which time the hose shall not leak nor shall any jacket thread break during the test.

(2) Maintenance.

(i) The employer shall assure that water supply tanks are kept filled to the proper level except during repairs. When pressure tanks are used, the employer shall assure that proper pressure is maintained at all times except during repairs.

(ii) The employer shall assure that valves in the main piping connections to the automatic sources of water supply are kept fully open at all times except during repair.

(iii) The employer shall assure that hose systems are inspected at least annually and after each use to assure that all of the equipment and hose are in place, available for use, and in serviceable condition.

(iv) When the system or any portion thereof is found not to be serviceable, the employer shall remove it from service immediately and replace it with equivalent protection such as extinguishers and fire watches.

(v) The employer shall assure that hemp or linen hose on existing systems is unracked, physically inspected for deterioration, and racked using a different fold pattern at least annually. The employer shall assure that defective hose is replaced in accordance with paragraph (c)(3)(ii).

(vi) The employer shall designate trained persons to conduct all inspections required under this section.

[45 FR 60710, Sept. 12, 1980]

Stat. Auth.: ORS 654.025(2) and 656.726(4).

Stats. Implemented: ORS 654.001 through 654.295.

Hist: OR-OSHA Admin. Order 14-1993, f. 8/27/93, ef. 11/1/93.
OR-OSHA Admin. Order 4-1997, f. 4/2/97, ef. 4/2/97.

Fixed Fire Suppression Equipment

§1910.159 Automatic Sprinkler Systems.

(a) Scope and application.

(1) The requirements of this section apply to all automatic sprinkler systems installed to meet a particular OSHA standard.

(2) For automatic sprinkler systems used to meet OSHA requirements and installed prior to the effective date of this standard, compliance with the National Fire Protection Association (NFPA) or the National Board of Fire Underwriters (NBFU) standard in effect at the time of the system's installation will be acceptable as compliance with this section.

(b) **Exemptions.** Automatic sprinkler systems installed in workplaces, but not required by OSHA, are exempt from the requirements of this section.

(c) General requirements.

(1) Design.

(i) All automatic sprinkler designs used to comply with this standard shall provide the necessary discharge patterns, densities, and water flow characteristics for complete coverage in a particular workplace or zoned subdivision of the workplace.

(ii) The employer shall assure that only approved equipment and devices are used in the design and installation of automatic sprinkler systems used to comply with this standard.

(2) **Maintenance.** The employer shall properly maintain an automatic sprinkler system installed to comply with this section. The employer shall assure that a main drain flow test is performed on each system annually. The inspector's test valve shall be opened at least every 2 years to assure that the sprinkler system operates properly.

(3) **Acceptance tests.** The employer shall conduct proper acceptance tests on sprinkler systems installed for employee protection after January 1, 1981, and record the dates of such tests. Proper acceptance tests include the following:

(i) Flushing of underground connections;

(ii) Hydrostatic tests of piping in system;

(iii) Air tests in dry-pipe systems;

(iv) Dry-pipe valve operation; and

(v) Test of drainage facilities.

(4) Water supplies. The employer shall assure that every automatic sprinkler system is provided with at least one automatic water supply capable of providing design water flow for at least 30 minutes. An auxiliary water supply or equivalent protection shall be provided when the automatic water supply is out of service, except for systems of 20 or fewer sprinklers.

(5) Hose connections for fire fighting use. The employer may attach hose connections for fire fighting use to wet pipe sprinkler systems provided that the water supply satisfies the combined design demand for sprinklers and standpipes.

(6) Protection of piping. The employer shall assure that automatic sprinkler system piping is protected against freezing and exterior surface corrosion.

(7) Drainage. The employer shall assure that all dry sprinkler pipes and fittings are installed so that the system may be totally drained.

(8) Sprinklers.

(i) The employer shall assure that only approved sprinklers are used on systems.

(ii) The employer may not use older style sprinklers to replace standard sprinklers without a complete engineering review of the altered part of the system.

(iii) The employer shall assure that sprinklers are protected from mechanical damage.

(9) Sprinkler alarms. On all sprinkler systems having more than 20 sprinklers, the employer shall assure that a local waterflow alarm is provided which sounds an audible signal on the premises upon water flow through the system equal to the flow from a single sprinkler.

(10) Sprinkler spacing. The employer shall assure that sprinklers are spaced to provide a maximum protection area per sprinkler, a minimum of interference to the discharge pattern by building or structural members or building contents and suitable sensitivity to possible fire hazards. The minimum vertical clearance between sprinklers and material below shall be 18 inches (45.7 cm).

(11) Hydraulically designed systems. The employer shall assure that hydraulically designed automatic sprinkler systems or portions thereof are identified and that the location, number of sprinklers in the hydraulically designed section, and the basis of the design is indicated. Central records may be used in lieu of signs at sprinkler valves provided the records are available for inspection and copying by the Assistant Secretary.

[45 FR 60710, Sept. 12, 1980; 46 FR 24557, May 1, 1981]

Stat. Auth.: ORS 654.025(2) and 656.726(4).

Stats. Implemented: ORS 654.001 through 654.295.

Hist: OR-OSHA Admin. Order 14-1993, f. 8/27/93, ef. 11/1/93.

§1910.160 Fixed Extinguishing Systems, General.

(a) Scope and application.

(1) This section applies to all fixed extinguishing systems installed to meet a particular OSHA standard except for automatic sprinkler systems which are covered by §1910.159.

(2) This section also applies to fixed systems not installed to meet a particular OSHA standard, but which, by means of their operation, may expose employees to possible injury, death, or adverse health consequences caused by the extinguishing agent. Such systems are only subject to the requirements of paragraphs (b)(4) through (b)(7) and (c) of this section.

(3) Systems otherwise covered in paragraph (a)(2) of this section which are installed in areas with no employee exposure are exempted from the requirements of this section.

(b) General requirements.

(1) Fixed extinguishing system components and agents shall be designed and approved for use on the specific fire hazards they are expected to control or extinguish.

(2) If for any reason a fixed extinguishing system becomes inoperable, the employer shall notify employees and take the necessary temporary precautions to assure their safety until the system is restored to operating order. Any defects or impairments shall be properly corrected by trained personnel.

(3) The employer shall provide a distinctive alarm or signaling system which complies with §1910.165 and is capable of being perceived above ambient noise or light levels, on all extinguishing systems in those portions of the workplace covered by the extinguishing system to indicate when the extinguishing system is discharging. Discharge alarms are not required on systems where discharge is immediately recognizable.

(4) The employer shall provide effective safeguards to warn employees against entry into discharge areas where the atmosphere remains hazardous to employee safety or health.

(5) The employer shall post hazard warning or caution signs at the entrance to, and inside of, areas protected by fixed extinguishing systems which use agents in concentrations known to be hazardous to employee safety and health.

(6) The employer shall assure that fixed systems are inspected annually by a person knowledgeable in the design and function of the system to assure that the system is maintained in good operating condition.

(7) The employer shall assure that the weight and pressure of refillable containers is checked at least semiannually. If the container shows a loss in net content or weight of more than 5 percent, or a loss in pressure of more than 10 percent, it shall be subjected to maintenance.

(8) The employer shall assure that factory charged nonrefillable containers which have no means of pressure indication are weighed at least semiannually. If a container shows a loss in net weight or more than 5 percent it shall be replaced.

(9) The employer shall assure that inspection and maintenance dates are recorded on the container, on a tag attached to the container, or in a central location. A record of the last semiannual check shall be maintained until the container is checked again or for the life of the container, whichever is less.

(10) The employer shall train employees designated to inspect, maintain, operate, or repair fixed extinguishing systems and annually review their training to keep them up-to-date in the functions they are to perform.

(11) The employer shall not use chlorobromomethane or carbon tetrachloride as an extinguishing agent where employees may be exposed.

(12) The employer shall assure that systems installed in the presence of corrosive atmospheres are constructed of noncorrosive material or otherwise protected against corrosion.

(13) Automatic detection equipment shall be approved, installed and maintained in accordance with §1910.164.

(14) The employer shall assure that all systems designed for and installed in areas with climatic extremes shall operate effectively at the expected extreme temperatures.

(15) The employer shall assure that at least one manual station is provided for discharge activation of each fixed extinguishing system.

(16) The employer shall assure that manual operating devices are identified as to the hazard against which they will provide protection.

(17) The employer shall provide and assure the use of the personal protective equipment needed for immediate rescue of employees trapped in hazardous atmospheres created by an agent discharge.

(c) Total flooding systems with potential health and safety hazards to employees.

(1) The employer shall provide an emergency action plan in accordance with §1910.38 for each area within a workplace that is protected by a total flooding system which provides agent concentrations exceeding the maximum safe levels set forth in paragraphs (b)(5) and (b)(6) of §1910.162. *NOTE: 1910.38 is now 437-002-0042 and 0043.*

(2) Systems installed in areas where employees cannot enter during or after the system's operation are exempt from the requirements of paragraph (c) of this section.

(3) On all total flooding systems the employer shall provide a predischarge employee alarm which complies with §1910.165, and is capable of being perceived above ambient light or noise levels before the system discharges, which will give employees time to safely exit from the discharge area prior to system discharge.

(4) The employer shall provide automatic actuation of total flooding systems by means of an approved fire detection device installed and interconnected with a predischarge employee alarm system to give employees time to safely exit from the discharge area prior to system discharge.

[45 FR 60711, Sept. 12, 1980]

Stat. Auth.: ORS 654.025(2) and 656.726(4).

Stats. Implemented: ORS 654.001 through 654.295.

Hist: OR-OSHA Admin. Order 14-1993, f. 8/27/93, ef. 11/1/93.
OR-OSHA Admin. Order 12-2001, f. 10/26/01, ef. 10/26/01.

FIRE PROTECTION L

§1910.161 Fixed Extinguishing Systems, Dry Chemical.

(a) Scope and application. This section applies to all fixed extinguishing systems, using dry chemical as the extinguishing agent, installed to meet a particular OSHA standard. These systems shall also comply with §1910.160.

(b) Specific requirements.

(1) The employer shall assure that dry chemical agents are compatible with any foams or wetting agents with which they are used.

(2) The employer may not mix together dry chemical extinguishing agents of different compositions. The employer shall assure that dry chemical systems are refilled with the chemical stated on the approval nameplate or an equivalent compatible material.

(3) When dry chemical discharge may obscure vision, the employer shall provide a pre-discharge employee alarm which complies with §1910.165 and which will give employees time to safely exit from the discharge area prior to system discharge.

(4) The employer shall sample the dry chemical supply of all but stored pressure systems at least annually to assure that the dry chemical supply is free of moisture which may cause the supply to cake or form lumps.

(5) The employer shall assure that the rate of application of dry chemicals is such that the designed concentration of the system will be reached within 30 seconds of initial discharge.

[45 FR 60712, Sept. 12, 1980]

Stat. Auth.: ORS 654.025(2) and 656.726(4).

Stats. Implemented: ORS 654.001 through 654.295.

Hist: OR-OSHA Admin. Order 14-1993, f. 8/27/93, ef. 11/1/93.

FIRE PROTECTION L

§1910.162 Fixed Extinguishing Systems, Gaseous Agent.

(a) Scope and application.

(1) Scope. This section applies to all fixed extinguishing systems, using a gas as the extinguishing agent, installed to meet a particular OSHA standard. These systems shall also comply with §1910.160. In some cases, the gas may be in a liquid state during storage.

(2) Application. The requirements of paragraphs (b)(2) and (b)(4) through (b)(6) shall apply only to total flooding systems.

(b) Specific requirements.

(1) Agents used for initial supply and replenishment shall be of the type approved for the system's application. Carbon dioxide obtained by dry ice conversion to liquid is not acceptable unless it is processed to remove excess water and oil.

(2) Except during overhaul, the employer shall assure that the designed concentration of gaseous agents is maintained until the fire has been extinguished or is under control.

(3) The employer shall assure that employees are not exposed to toxic levels of gaseous agent or its decomposition products.

(4) The employer shall assure that the designed extinguishing concentration is reached within 30 seconds of initial discharge except for Halon systems which must achieve design concentration within 10 seconds.

(5) The employer shall provide a distinctive predischARGE employee alarm capable of being perceived above ambient light or noise levels when agent design concentrations exceed the maximum safe level for employee exposure. A predischARGE employee alarm for alerting employees before system discharge shall be provided on Halon 1211 and carbon dioxide systems with a design concentration of 4 percent or greater and for Halon 1301 systems with a design concentration of 10 percent or greater. The predischARGE employee alarm shall provide employees time to safely exit the discharge area prior to system discharge.

(6)

(i) Where egress from an area cannot be accomplished within 1-minute, the employer shall not use Halon 1301 in concentrations greater than 7 percent.

(ii) Where egress takes greater than 30 seconds but less than 1-minute, the employer shall not use Halon 1301 in a concentration greater than 10 percent.

(iii) Halon 1301 concentrations greater than 10 percent are only permitted in areas not normally occupied by employees provided that any employee in the area can escape within 30 seconds. The employer shall assure that no unprotected employees enter the area during agent discharge.

[45 FR 60712, Sept. 12, 1980; 46 FR 24557, May 1, 1981]

Stat. Auth.: ORS 654.025(2) and 656.726(4).

Stats. Implemented: ORS 654.001 through 654.295.

Hist: OR-OSHA Admin. Order 14-1993, f. 8/27/93, ef. 11/1/93.

§1910.163 Fixed Extinguishing Systems, Water Spray and Foam.

(a) Scope and application. This section applies to all fixed extinguishing systems, using water or foam solution as the extinguishing agent, installed to meet a particular OSHA standard. These systems shall also comply with §1910.160. This section does not apply to automatic sprinkler systems which are covered under §1910.159.

(b) Specific requirements.

(1) The employer shall assure that foam and water spray systems are designed to be effective in at least controlling fire in the protected area or on protected equipment.

(2) The employer shall assure that drainage of water spray systems is directed away from areas where employees are working and that no emergency egress is permitted through the drainage path.

[45 FR 60712, Sept. 12, 1980]

Stat. Auth.: ORS 654.025(2) and 656.726(4).

Stats. Implemented: ORS 654.001 through 654.295.

Hist: OR-OSHA Admin. Order 14-1993, f. 8/27/93, ef. 11/1/93.

FIRE PROTECTION L

Other Fire Protection Systems

§1910.164 Fire Detection Systems.

(a) Scope and application. This section applies to all automatic fire detection systems installed to meet the requirements of a particular OSHA standard.

(b) Installation and restoration.

(1) The employer shall assure that all devices and equipment constructed and installed to comply with this standard are approved for the purpose for which they are intended.

(2) The employer shall restore all fire detection systems and components to normal operating condition as promptly as possible after each test or alarm. Spare detection devices and components which are normally destroyed in the process of detecting fires shall be available on the premises or from a local supplier in sufficient quantities and locations for prompt restoration of the system.

(c) Maintenance and testing.

(1) The employer shall maintain all systems in an operable condition except during repairs or maintenance.

(2) The employer shall assure that fire detectors and fire detection systems are tested and adjusted as often as needed to maintain proper reliability and operating condition except that factory calibrated detectors need not be adjusted after installation.

(3) The employer shall assure that pneumatic and hydraulic operated detection systems installed after January 1, 1981, are equipped with supervised systems.

(4) The employer shall assure that the servicing, maintenance and testing of fire detection systems, including cleaning and necessary sensitivity adjustments are performed by a trained person knowledgeable in the operations and functions of the system.

(5) The employer shall also assure that fire detectors that need to be cleaned of dirt, dust, or other particulates in order to be fully operational are cleaned at regular periodic intervals.

(d) Protection of fire detectors.

(1) The employer shall assure that fire detection equipment installed outdoors or in the presence of corrosive atmospheres be protected from corrosion. The employer shall provide a canopy, hood, or other suitable protection for detection equipment requiring protection from the weather.

(2) The employer shall locate or otherwise protect detection equipment so that it is protected from mechanical or physical impact which might render it inoperable.

(3) The employer shall assure that detectors are supported independently of their attachment to wires or tubing.

(e) Response time.

(1) The employer shall assure that fire detection systems installed for the purpose of actuating fire extinguishment or suppression systems shall be designed to operate in time to control or extinguish a fire.

(2) The employer shall assure that fire detection systems installed for the purpose of employee alarm and evacuation be designed and installed to provide a warning for emergency action and safe escape of employees.

(3) The employer shall not delay alarms or devices initiated by fire detector actuation for more than 30 seconds unless such delay is necessary for the immediate safety of employees. When such delay is necessary, it shall be addressed in an emergency action plan meeting the requirements of §1910.38. *NOTE: 1910.38 is now 437-002-0042 and 0043.*

(f) Number, location and spacing of detecting devices. The employer shall assure that the number, spacing and location of fire detectors is based upon design data obtained from field experience, or tests, engineering surveys, the manufacturer's recommendations, or a recognized testing laboratory listing.

[45 FR 60713, Sept. 12, 1980]

Stat. Auth.: ORS 654.025(2) and 656.726(4).

Stats. Implemented: ORS 654.001 through 654.295.

Hist: OR-OSHA Admin. Order 14-1993, f. 8/27/93, ef. 11/1/93.
OR-OSHA Admin. Order 12-2001, f. 10/26/01, ef. 10/26/01.

§1910.165 Employee Alarm Systems.

(a) Scope and application.

(1) This section applies to all emergency employee alarms installed to meet a particular OSHA standard. This section does not apply to those discharge or supervisory alarms required on various fixed extinguishing systems or to supervisory alarms on fire suppression, alarm or detection systems unless they are intended to be employee alarm systems.

(2) The requirements in this section that pertain to maintenance, testing and inspection shall apply to all local fire alarm signaling systems used for alerting employees regardless of the other functions of the system.

(3) All predischarge employee alarms installed to meet a particular OSHA standard shall meet the requirements of paragraphs (b)(1) through (4), (c), and (d)(1) of this section.

(b) General requirements.

(1) The employee alarm system shall provide warning for necessary emergency action as called for in the emergency action plan, or for reaction time for safe escape of employees from the workplace or the immediate work area, or both.

(2) The employee alarm shall be capable of being perceived above ambient noise or light levels by all employees in the affected portions of the workplace. Tactile devices may be used to alert those employees who would not otherwise be able to recognize the audible or visual alarm.

(3) The employee alarm shall be distinctive and recognizable as a signal to evacuate the work area or to perform actions designated under the emergency action plan.

(4) The employer shall explain to each employee the preferred means of reporting emergencies, such as manual pull box alarms, public address systems, radio or telephones. The employer shall post emergency telephone numbers near telephones, or employee notice boards, and other conspicuous locations when telephones serve as a means of reporting emergencies. Where a communication system also serves as the employee alarm system, all emergency messages shall have priority over all nonemergency messages.

(5) The employer shall establish procedures for sounding emergency alarms in the workplace. For those employers with 10 or fewer employees in a particular workplace, direct voice communication is an acceptable procedure for sounding the alarm provided all employees can hear the alarm. Such workplaces need not have a backup system.

(c) Installation and restoration.

(1) The employer shall assure that all devices, components, combinations of devices or systems constructed and installed to comply with this standard are approved. Steam whistles, air horns, strobe lights or similar lighting devices, or tactile devices meeting the requirements of this section are considered to meet this requirement for approval.

(2) The employer shall assure that all employee alarm systems are restored to normal operating condition as promptly as possible after each test or alarm. Spare alarm devices and components subject to wear or destruction shall be available in sufficient quantities and locations for prompt restoration of the system.

(d) Maintenance and testing.

(1) The employer shall assure that all employee alarm systems are maintained in operating condition except when undergoing repairs or maintenance.

(2) The employer shall assure that a test of the reliability and adequacy of nonsupervised employee alarm systems is made every 2 months. A different actuation device shall be used in each test of a multiactuation device system so that no individual device is used for two consecutive tests.

(3) The employer shall maintain or replace power supplies as often as is necessary to assure a fully operational condition. Backup means of alarm, such as employee runners or telephones, shall be provided when systems are out of service.

(4) The employer shall assure that employee alarm circuitry installed after January 1, 1981, which is capable of being supervised is supervised and that it will provide positive notification to assigned personnel whenever a deficiency exists in the system. The employer shall assure that all supervised employee alarm systems are tested at least annually for reliability and adequacy.

(5) The employer shall assure that the servicing, maintenance and testing of employee alarms are done by persons trained in the designed operation and functions necessary for reliable and safe operation of the system.

(e) Manual operation. The employer shall assure that manually operated actuation devices for use in conjunction with employee alarms are unobstructed, conspicuous and readily accessible.

[45 FR 60713, Sept. 12, 1980]

Stat. Auth.: ORS 654.025(2) and 656.726(4).

Stats. Implemented: ORS 654.001 through 654.295.

Hist: OR-OSHA Admin. Order 14-1993, f. 8/27/93, ef. 11/1/93.

NOTE: The following appendices to Subdivision L, except Appendix E, serve as **nonmandatory** guidelines to assist employers in complying with the appropriate requirements of Subdivision L.

Appendix A to Subdivision L – Fire Protection

§1910.156 Fire Brigades.

1. Scope. This section does not require an employer to organize a fire brigade. However, if an employer does decide to organize a fire brigade, the requirements of this section apply.

2. Pre-fire planning. It is suggested that pre-fire planning be conducted by the local fire department and/or the workplace fire brigade in order for them to be familiar with the workplace and process hazards. Involvement with the local fire department or fire prevention bureau is encouraged to facilitate coordination and cooperation between members of the fire brigade and those who might be called upon for assistance during a fire emergency.

3. Organizational statement. In addition to the information required in the organizational statement, paragraph 1910.156(b)(1), it is suggested that the organizational statement also contain the following information: a description of the duties that the fire brigade members are expected to perform; the line authority of each fire brigade officer; the number of the fire brigade officers and number of training instructors; and a list and description of the types of awards or recognition that brigade members may be eligible to receive.

4. Physical capability. The physical capability requirement applies only to those fire brigade members who perform interior structural fire fighting. Employees who cannot meet the physical capability requirement may still be members of the fire brigade as long as such employees do not perform interior structural fire fighting. It is suggested that fire brigade members who are unable to perform interior structural fire fighting be assigned less stressful and physically demanding fire brigade duties, e.g., certain types of training, recordkeeping, fire prevention inspection and maintenance, and fire pump operations.

Physically capable can be defined as being able to perform those duties specified in the training requirements of section 1910.156(c). Physically capable can also be determined by physical performance tests or by a physical examination when the examining physician is aware of the duties that the fire brigade member is expected to perform.

It is also recommended that fire brigade members participate in a physical fitness program. There are many benefits which can be attributed to being physically fit. It is believed that physical fitness may help to reduce the number of sprain and strain injuries as well as contributing to the improvement of the cardiovascular system.

5. Training and education. The paragraph on training and education does not contain specific training and education requirements because the type, amount, and frequency of training and education will be as varied as are the purposes for which fire brigades are organized. However, the paragraph does require that training and education be commensurate with those functions that the fire brigade is expected to perform; i.e., those functions specified in the organizational statement. Such a performance requirement provides the necessary flexibility to design a training program which meets the needs of individual fire brigades.

At a minimum, hands-on training is required to be conducted annually for all fire brigade members. However, for those fire brigade members who are expected to perform interior structural fire fighting, some type of training or education session must be provided at least quarterly.

In addition to the required hands-on training, it is strongly recommended that fire brigade members receive other types of training and education such as: classroom instruction, review of emergency action procedures, pre-fire planning, review of special hazards in the workplace, and practice in the use of self-contained breathing apparatus.

It is not necessary for the employer to duplicate the same training or education that a fire brigade member receives as a member of a community volunteer fire department, rescue squad, or similar organization. However, such training or education must have been provided to the fire brigade member within the past year and it must be documented that the fire brigade member has received the training or education. For example: there is no need for a fire brigade member to receive another training class in the use of positive-pressure self-contained breathing apparatus if the fire brigade member has recently completed such training as a member of a community fire department. Instead, the fire brigade member should receive training or education covering other important equipment or duties of the fire brigade as they relate to the workplace hazards, facilities and processes.

It is generally recognized that the effectiveness of fire brigade training and education depends upon the expertise of those providing the training and education as well as the motivation of the fire brigade members. Fire brigade training instructors must receive a higher level of training and education than the fire brigade members they will be teaching. This includes being more knowledgeable about the functions to be performed by the fire brigade and the hazards involved. The instructors should be qualified to train fire brigade members and demonstrate skills in communication, methods of teaching, and motivation. It is important for instructors and fire brigade members alike to be motivated toward the goals of the fire brigade and be aware of the importance of the service that they are providing for the protection of other employees and the workplace.

It is suggested that publications from the International Fire Service Training Association, the National Fire Protection Association (NFPA-1041), the International Society of Fire Service Instructors and other fire training sources be consulted for recommended qualifications of fire brigade training instructors.

In order to be effective, fire brigades must have competent leadership and supervision. It is important for those who supervise the fire brigade during emergency situations, e.g., fire brigade chiefs, leaders, etc., to receive the necessary training and education for supervising fire brigade activities during these hazardous and stressful situations. These fire brigade members with leadership responsibilities should demonstrate skills in strategy and tactics, fire suppression and prevention techniques, leadership principles, pre-fire planning, and safety practices. It is again suggested that fire service training sources be consulted for determining the kinds of training and education which are necessary for those with fire brigade leadership responsibilities.

It is further suggested that fire brigade leaders and fire brigade instructors receive more formalized training and education on a continuing basis by attending classes provided by such training sources as universities and university fire extension services.

The following recommendations should not be considered to be all of the necessary elements of a complete comprehensive training program, but the information may be helpful as a guide in developing a fire brigade training program.

All fire brigade members should be familiar with exit facilities and their location, emergency escape routes for handicapped workers, and the workplace "emergency action plan."

In addition, fire brigade members who are expected to control and extinguish fires in the incipient stage should, at a minimum, be trained in the use of fire extinguishers, standpipes, and other fire equipment they are assigned to use. They should also be aware of first aid medical procedures and procedures for dealing with special hazards to which they may be exposed. Training and education should include both classroom instruction and actual operation of the equipment under simulated emergency conditions. Hands-on type training must be conducted at least annually but some functions should be reviewed more often.

In addition to the above training, fire brigade members who are expected to perform emergency rescue and interior structural fire fighting should, at a minimum, be familiar with the proper techniques in rescue and fire suppression procedures. Training and education should include fire protection courses, classroom training, simulated fire situations including "wet drills" and, when feasible, extinguishment of actual mock fires. Frequency of training or education must be at least quarterly, but some drills or classroom training should be conducted as often as monthly or even weekly to maintain the proficiency of fire brigade members.

There are many excellent sources of training and education that the employer may want to use in developing a training program for the workplace fire brigade. These sources include publications, seminars, and courses offered by universities.

There are also excellent fire school courses by such facilities as Texas A and M University, Delaware State Fire School, Lamar University, and Reno Fire School, that deal with those unique hazards which may be encountered by fire brigades in the oil and chemical industry. These schools, and others, also offer excellent training courses which would be beneficial to fire brigades in other types of industries. These courses should be a continuing part of the training program, and employers are strongly encouraged to take advantage of these excellent resources.

It is also important that fire brigade members be informed about special hazards to which they may be exposed during fire and other emergencies. Such hazards as storage and use areas of flammable liquids and gases, toxic chemicals, water-reactive substances, etc., can pose difficult problems. There must be written procedures developed that describe the actions to be taken in situations involving special hazards. Fire brigade members must be trained in handling these special hazards as well as keeping abreast of any changes that occur in relation to these special hazards.

6. Fire fighting equipment. It is important that fire fighting equipment that is in damaged or unserviceable condition be removed from service and replaced. This will prevent fire brigade members from using unsafe equipment by mistake.

Fire fighting equipment, except portable fire extinguishers and respirators, must be inspected at least annually. Portable fire extinguishers and respirators are required to be inspected at least monthly.

7. Protective clothing.

(A) General. Paragraph (e) of §1910.156 does not require all fire brigade members to wear protective clothing. It is not the intention of these standards to require employers to provide a full ensemble of protective clothing for every fire brigade member without consideration given to the types of hazardous environments to which the fire brigade member might be exposed. It is the intention of these standards to require adequate protection for those fire brigade members who might be exposed to fires in an advanced stage, smoke, toxic gases, and high temperatures. Therefore, the protective clothing requirements only apply to those fire brigade members who perform interior structural fire fighting operations.

Additionally, the protective clothing requirements do not apply to the protective clothing worn during outside fire fighting operations (brush and forest fires, crash crew operations) or other special fire fighting activities. It is important that the protective clothing to be worn during these types of fire fighting operations reflect the hazards which are expected to be encountered by fire brigade members.

(B) Foot and leg protection. Section 1910.156 permits an option to achieve foot and leg protection.

The section recognizes the interdependence of protective clothing to cover one or more parts of the body. Therefore, an option is given so that fire brigade members may meet the foot and leg requirements by either wearing long fire-resistive coats in combination with fully extended boots, or by wearing shorter fire-resistive coats in combination with protective trousers and protective shoes or shorter boots.

(C) Body protection. Paragraph (e)(3) of §1910.156 provides an option for fire brigade members to achieve body protection. Fire brigade members may wear a fire-resistive coat in combination with fully extended boots, or they may wear a fire-resistive coat in combination with protective trousers.

Fire-resistive coats and protective trousers meeting all of the requirements contained in NFPA 1971-1975 "Protective Clothing for Structural Fire Fighters," are acceptable as meeting the requirements of this standard.

The lining is required to be permanently attached to the outer shell. However, it is permissible to attach the lining to the outer shell material by stitching in one area such as at the neck. Fastener tape or snap fasteners may be used to secure the rest of the lining to the outer shell to facilitate cleaning. Reference to permanent lining does not refer to a winter liner which is a detachable extra lining used to give added protection to the wearer against the effects of cold weather and wind.

(D) Hand protection. The requirements of the paragraph on hand protection may be met by protective gloves or a glove system. A glove system consists of a combination of different gloves. The usual components of a glove system consist of a pair of gloves, which provide thermal insulation to the hands, worn in combination with a second pair of gloves which provide protection against flame, cut, and puncture.

It is suggested that protective gloves provide dexterity and a sense of feel for objects. Criteria and test methods for dexterity are contained in the NIOSH publications, "The Development of Criteria for Firefighters' Gloves; Vol. I: Glove Requirements" and "Vol. II: Glove Criteria and Test Methods." These NIOSH publications also contain a permissible modified version of Federal Test Method 191, Method 5903, (paragraph (3) of Appendix E) for flame-resistance when gloves, rather than glove material, are tested for flame-resistance.

(E) Head, eye, and face protection. Head protective devices which meet the requirements contained in NFPA No. 1972 are acceptable as meeting the requirements of this standard for head protection.

Head protective devices are required to be provided with ear flaps so that the ear flaps will be available if needed. It is recommended that ear protection always be used while fighting interior structural fires.

Many head protective devices are equipped with face shields to protect the eyes and face. These face shields are permissible as meeting the eye and face protection requirements of this paragraph as long as such face shields meet the requirements of §1910.133 of the General Industry Standards.

Additionally, full facepieces, helmets or hoods of approved breathing apparatus which meet the requirements of §1910.134 and paragraph (f) of §1910.156 are also acceptable as meeting the eye and face protection requirements.

It is recommended that a flame-resistant protective head covering such as a hood or snood, which will not adversely affect the seal of a respirator facepiece, be worn during interior structural fire fighting operations to protect the sides of the face and hair.

8. Respiratory protective devices. Respiratory protection is required to be worn by fire brigade members while working inside buildings or confined spaces where toxic products of combustion or an oxygen deficiency is likely to be present; respirators are also to be worn during emergency situations involving toxic substances. When fire brigade members respond to emergency situations, they may be exposed to unknown contaminants in unknown concentrations. Therefore, it is imperative that fire brigade members wear proper respiratory protective devices during these situations. Additionally, there are many instances where toxic products of combustion are still present during mop-up and overhaul operations. Therefore, fire brigade members should continue to wear respirators during these types of operations.

Self-contained breathing apparatus are not required to be equipped with either a buddy-breathing device or a quick-disconnect valve. However, these accessories may be very useful and are acceptable as long as such accessories do not cause damage to the apparatus, restrict the air flow of the apparatus, or obstruct the normal operation of the apparatus.

Buddy-breathing devices are useful for emergency situations where a victim or another fire brigade member can share the same air supply with the wearer of the apparatus for emergency escape purposes.

The employer is encouraged to provide fire brigade members with an alternative means of respiratory protection to be used only for emergency escape purposes if the self-contained breathing apparatus becomes inoperative. Such alternative means of respiratory protection may be either a buddy-breathing device or an escape self-contained breathing apparatus (ESCBA). The ESCBA is a short-duration respiratory protective device which is approved for only emergency escape purposes. It is suggested that if ESCBA units are used, that they be of at least 5 minutes service life.

Quick-disconnect valves are devices which start the flow of air by insertion of the hose (which leads to the facepiece) into the regulator of self-contained breathing apparatus, and stop the flow of air by disconnecting the hose from the regulator. These devices are particularly useful for those positive-pressure self-contained breathing apparatus which do not have the capability of being switched from the demand to the positive-pressure mode.

The use of a self-contained breathing apparatus where the apparatus can be switched from a demand to a positive-pressure mode is acceptable as long as the apparatus is in the positive-pressure mode when performing interior structural fire fighting operations. Also acceptable are approved respiratory protective devices which have been converted to the positive-pressure type when such modification is accomplished by trained and experienced persons using kits or parts approved by NIOSH and provided by the manufacturer and by following the manufacturer's instructions.

There are situations which require the use of respirators which have a duration of 2 hours or more. Presently, there are no approved positive-pressure apparatus with a rated service life of more than 2 hours. Consequently, negative-pressure self-contained breathing apparatus with a rated service life of more than 2 hours and which have a minimum protection factor of 5,000 as determined by an acceptable quantitative fit test performed on each individual, will

be acceptable for use during situations which require long duration apparatus. Long duration apparatus may be needed in such instances as working in tunnels, subway systems, etc. Such negative-pressure breathing apparatus will continue to be acceptable for a maximum of 18 months after a positive-pressure apparatus with the same or longer rated service life of more than 2 hours is certified by NIOSH/MSHA. After this 18-month phase-in period, all self-contained breathing apparatus used for these long duration situations will have to be of the positive-pressure type.

Protection factor (sometimes called fit factor) is defined as the ratio of the contaminant concentrations outside of the respirator to the contaminant concentrations inside the facepiece of the respirator.

$$PF = \frac{\text{Concentration outside respirator}}{\text{Concentration inside facepiece}}$$

Protection factors are determined by quantitative fit tests. An acceptable quantitative fit test should include the following elements:

1. A fire brigade member who is physically and medically capable of wearing respirators, and who is trained in the use of respirators, dons a self-contained breathing apparatus equipped with a device that will monitor the concentration of a contaminant inside the facepiece.
2. The fire brigade member then performs a qualitative fit test to assure the best face to facepiece seal as possible. A qualitative fit test can consist of a negative-pressure test, positive-pressure test, isoamyl acetate vapor (banana oil) test, or an irritant smoke test. For more details on respirator fitting see the NIOSH booklet entitled "A Guide to Industrial Respiratory Protection" June, 1976, and HEW publication No. (NIOSH) 76-189.
3. The wearer should then perform physical activity which reflects the level of work activity which would be expected during fire fighting activities. The physical activity should include simulated fire-round work activity or physical exercise such as running-in-place, a step test, etc.
4. Without readjusting the apparatus, the wearer is placed in a test atmosphere containing a nontoxic contaminant with a known, constant, concentration.

The protection factor is then determined by dividing the known concentration of the contaminant in the test atmosphere by the concentration of the contaminant inside the facepiece when the following exercises are performed:

- (a) Normal breathing with head motionless for 1-minute;
- (b) Deep breathing with head motionless for 30 seconds;
- (c) Turning head slowly from side to side while breathing normally, pausing for at least two breaths before changing direction. Continue for at least 1-minute;

- (d) Moving head slowly up and down while breathing normally, pausing for at least two breaths before changing direction. Continue for at least 2 minutes;
- (e) Reading from a prepared text, slowly and clearly, and loudly enough to be heard and understood. Continue for 1-minute; and
- (f) Normal breathing with head motionless for at least 1-minute.

The protection factor which is determined must be at least 5,000. The quantitative fit test should be conducted at least three times. It is acceptable to conduct all three tests on the same day. However, there should be at least 1-hour between tests to reflect the protection afforded by the apparatus during different times of the day.

The above elements are not meant to be a comprehensive, technical description of a quantitative fit test protocol. However, quantitative fit test procedures which include these elements are acceptable for determining protection factors. Procedures for a quantitative fit test are required to be available for inspection by the Assistant Secretary or authorized representative.

Organizations such as Los Alamos Scientific Laboratory, Lawrence Livermore Laboratory, NIOSH, and American National Standards Institute (ANSI) are excellent sources for additional information concerning qualitative and quantitative fit testing.

§1910.157 Portable Fire Extinguishers.

1. Scope and application. The scope and application of this section is written to apply to three basic types of workplaces. First, there are those workplaces where the employer has chosen to evacuate all employees from the workplace at the time of a fire emergency. Second, there are those workplaces where the employer has chosen to permit certain employees to fight fires and to evacuate all other nonessential employees at the time of a fire emergency. Third, there are those workplaces where the employer has chosen to permit all employees in the workplace to use portable fire extinguishers to fight fires.

The section also addresses two kinds of work areas. The entire workplace can be divided into outside (exterior) work areas and inside (interior) work areas. This division of the workplace into two areas is done in recognition of the different types of hazards employees may be exposed to during fire fighting operations. Fires in interior workplaces, pose a greater hazard to employees; they can produce greater exposure to quantities of smoke, toxic gases, and heat because of the capability of a building or structure to contain or entrap these products of combustion until the building can be ventilated. Exterior work areas, normally open to the environment, are somewhat less hazardous, because the products of combustion are generally carried away by the thermal column of the fire. Employees also have a greater selection of evacuation routes if it is necessary to abandon fire fighting efforts.

In recognition of the degree of hazard present in the two types of work areas, the standards for exterior work areas are somewhat less restrictive in regards to extinguisher distribution. Paragraph (a) explains this by specifying which paragraphs in the section apply.

2. Portable fire extinguisher exemptions. In recognition of the three options given to employers in regard to the amount of employee evacuation to be carried out, the standards permit certain exemptions based on the number of employees expected to use fire extinguishers.

Where the employer has chosen to totally evacuate the workplace at the time of a fire emergency and when fire extinguishers are not provided, the requirements of this section do not apply to that workplace.

Where the employer has chosen to partially evacuate the workplace or the effected area at the time of a fire emergency and has permitted certain designated employees to remain behind to operate critical plant operations or to fight fires with extinguishers, then the employer is exempt from the distribution requirements of this section. Employees who will be remaining behind to perform incipient fire fighting or members of a fire brigade must be trained in their duties. The training must result in the employees becoming familiar with the locations of fire extinguishers. Therefore, the employer must locate the extinguishers in convenient locations where the employees know they can be found. For example, they could be mounted in the fire truck or cart that the fire brigade uses when it responds to a fire emergency. They can also be distributed as set forth in the National Fire Protection Association's Standard No. 10, "Portable Fire Extinguishers."

Where the employer has decided to permit all employees in the workforce to use fire extinguishers, then the entire OSHA section applies.

3. Portable fire extinguisher mounting. Previous standards for mounting fire extinguishers have been criticized for requiring specific mounting locations. In recognition of this criticism, the standard has been rewritten to permit as much flexibility in extinguisher mounting as is acceptable to assure that fire extinguishers are available when needed and that employees are not subjected to injury hazards when they try to obtain an extinguisher.

It is the intent of OSHA to permit the mounting of extinguishers in any location that is accessible to employees without the use of portable devices such as a ladder. This limitation is necessary because portable devices can be moved or taken from the place where they are needed and, therefore, might not be available at the time of an emergency.

Employers are given as much flexibility as possible to assure that employees can obtain extinguishers as fast as possible. For example, an acceptable method of mounting extinguishers in areas where forklift trucks or tow-motors are used is to mount the units on retractable boards which, by means of counterweighting, can be raised above the level where they could be struck by vehicular traffic. When needed, they can be lowered quickly for use. This method of mounting can also reduce vandalism and unauthorized use of extinguishers. The extinguishers may also be mounted as outlined in the National Fire Protection Association's Standard No. 10, "Portable Fire Extinguishers."

4. Selection and distribution. The employer is responsible for the proper selection and distribution of fire extinguishers and the determination of the necessary degree of protection. The selection and distribution of fire extinguishers must reflect the type and class of fire hazards associated with a particular workplace.

Extinguishers for protecting Class A hazards may be selected from the following types: water, foam, loaded stream, or multipurpose dry chemical. Extinguishers for protecting Class B hazards may be selected from the following types: Halon 1301, Halon 1211, carbon dioxide, dry chemicals, foam, or loaded stream. Extinguishers for Class C hazards may be selected from the following types: Halon 1301, Halon 1211, carbon dioxide, or dry chemical.

Combustible metal (Class D hazards) fires pose a different type of fire problem in the workplace. Extinguishers using water, gas, or certain dry chemicals cannot extinguish or control this type of fire. Therefore, certain metals have specific dry powder extinguishing agents which can extinguish or control this type of fire. Those agents which have been specifically approved for use on certain metal fires provide the best protection; however, there are also some "universal" type agents which can be used effectively on a variety of combustible metal fires if necessary. The "universal" type agents include: Foundry flux, Lith-X powder, TMB liquid, pyromet powder, TEC powder, dry talc, dry graphite powder, dry sand, dry sodium chloride, dry soda ash, lithium chloride, zirconium silicate, and dry dolomite.

Water is not generally accepted as an effective extinguishing agent for metal fires. When applied to hot burning metal, water will break down into its basic atoms of oxygen and hydrogen. This chemical breakdown contributes to the combustion of the metal. However, water is also a good universal coolant and can be used on some combustible metals, but only under proper conditions and application, to reduce the temperature of the burning metal below the ignition point. For example, automatic deluge systems in magnesium plants can discharge such large quantities of water on burning magnesium that the fire will be extinguished. The National Fire Protection Association has specific standards for this type of automatic sprinkler system. Further information on the control of metal fires with water can be found in the National Fire Protection Association's Fire Protection Handbook.

An excellent source of selection and distribution criteria is found in the National Fire Protection Association's Standard No. 10. Other sources of information include the National Safety Council and the employer's fire insurance carrier.

5. Substitution of standpipe systems for portable fire extinguishers. The employer is permitted to substitute acceptable standpipe systems for portable fire extinguishers under certain circumstances. It is necessary to assure that any substitution will provide the same coverage that portable units provide. This means that fire hoses, because of their limited portability, must be spaced throughout the protected area so that they can reach around obstructions such as columns, machinery, etc., and so that they can reach into closets and other enclosed areas.

6. Inspection, maintenance and testing. The ultimate responsibility for the inspection, maintenance and testing of portable fire extinguishers lies with the employer. The actual inspection, maintenance, and testing may, however, be conducted by outside contractors with whom the employer has arranged to do the work. When contracting for such work, the employer should assure that the contractor is capable of performing the work that is needed to comply with this standard.

If the employer should elect to perform the inspection, maintenance, and testing requirements of this section in-house, then the employer must make sure that those persons doing the work have been trained to do the work and to recognize problem areas which could

cause an extinguisher to be inoperable. The National Fire Protection Association provides excellent guidelines in its standard for portable fire extinguishers. The employer may also check with the manufacturer of the unit that has been purchased and obtain guidelines on inspection, maintenance, and testing. Hydrostatic testing is a process that should be left to contractors or individuals using suitable facilities and having the training necessary to perform the work.

Anytime the employer has removed an extinguisher from service to be checked or repaired, alternate equivalent protection must be provided. Alternate equivalent protection could include replacing the extinguisher with one or more units having equivalent or equal ratings, posting a fire watch, restricting the unprotected area from employee exposure, or providing a hose system ready to operate.

7. Hydrostatic testing. As stated before, the employer may contract for hydrostatic testing. However, if the employer wishes to provide the testing service, certain equipment and facilities must be available. Employees should be made aware of the hazards associated with hydrostatic testing and the importance of using proper guards and water pressures. Severe injury can result if extinguisher shells fail violently under hydrostatic pressure.

Employers are encouraged to use contractors who can perform adequate and reliable service. Firms which have been certified by the Materials Transportation Board (MTB) of the U.S. Department of Transportation (DOT) or State licensed extinguisher servicing firms or recognized by the National Association of Fire Equipment Distributors in Chicago, Illinois, are generally acceptable for performing this service.

8. Training and education. This part of the standard is of the utmost importance to employers and employees if the risk of injury or death due to extinguisher use is to be reduced. If an employer is going to permit an employee to fight a workplace fire of any size, the employer must make sure that the employee knows everything necessary to assure the employee's safety.

Training and education can be obtained through many channels. Often, local fire departments in larger cities have fire prevention bureaus or similar organizations which can provide basic fire prevention training programs. Fire insurance companies will have data and information available. The National Fire Protection Association and the National Safety Council will provide, at a small cost, publications that can be used in a fire prevention program.

Actual fire fighting training can be obtained from various sources in the country. The Texas A & M University, the University of Maryland's Fire and Rescue Institute, West Virginia University's Fire Service Extension, Iowa State University's Fire Service Extension and other State training schools and land grant colleges have fire fighting programs directed to industrial applications. Some manufacturers of extinguishers, such as the Ansul Company and Safety First, conduct fire schools for customers in the proper use of extinguishers. Several large corporations have taken time to develop their own on-site training programs which expose employees to the actual "feeling" of fire fighting. Simulated fires for training of employees in the proper use of extinguishers are also an acceptable part of a training program.

In meeting the requirements of this section, the employer may also provide educational materials, without classroom instruction, through the use of employee notice campaigns using instruction sheets or flyers or similar types of informal programs. The employer must make sure that employees are trained and educated to recognize not only what type of fire is being fought and how to fight it, but also when it is time to get away from it and leave fire suppression to more experienced fire fighters.

§1910.158 Standpipe and Hose Systems.

1. Scope and application. This section has been written to provide adequate coverage of those standpipe and hose systems that an employer may install in the workplace to meet the requirements of a particular OSHA standard. For example, OSHA permits the substitution of hose systems for portable fire extinguishers in §1910.157. If an employer chooses to provide hose systems instead of portable Class A fire extinguishers, then those hose systems used for substitution would have to meet the applicable requirements of §1910.157. All other standpipe and hose systems not used as a substitute would be exempt from these requirements.

The section specifically exempts Class I large hose systems. By large hose systems, OSHA means those 2 1/2-inch (6.3 cm) hose lines that are usually associated with fire departments of the size that provide their own water supply through fire apparatus. When the fire gets to the size that outside protection of that degree is necessary, OSHA believes that in most industries employees will have been evacuated from the fire area and the "professional" fire fighters will take control.

2. Protection of standpipes. Employers must make sure that standpipes are protected so that they can be relied upon during a fire emergency. This means protecting the pipes from mechanical and physical damage. There are various means for protecting the equipment such as, but not limited to, enclosing the supply piping in the construction of the building, locating the standpipe in an area which is inaccessible to vehicles, or locating the standpipe in a stairwell.

3. Hose covers and cabinets. The employer should keep fire protection hose equipment in cabinets or inside protective covers which will protect it from the weather elements, dirt or other damaging sources. The use of protective covers must be easily removed or opened to assure that hose and nozzle are accessible. When the employer places hose in a cabinet, the employer must make sure that the hose and nozzle are accessible to employees without subjecting them to injury. In order to make sure that the equipment is readily accessible, the employer must also make sure that the cabinets used to store equipment are kept free of obstructions and other equipment which may interfere with the fast distribution of the fire hose stored in the cabinet.

4. Hose outlets and connections. The employer must assure that employees who use standpipe and hose systems can reach the hose rack and hose valve without the use of portable equipment such as ladders. Hose reels are encouraged for use because one employee can retrieve the hose, charge it, and place it into service without much difficulty.

5. Hose. When the employer elects to provide small hose in lieu of portable fire extinguishers, those hose stations being used for the substitution must have hose attached and ready for service. However, if more than the necessary amount of small hose outlets are provided, hose does not have to be attached to those outlets that would provide redundant coverage. Further, where the installation of hose on outlets may expose the hose to extremely cold climates, the employer may store the hose in houses or similar protective areas and connect it to the outlet when needed.

There is approved lined hose available that can be used to replace unlined hose which is stored on racks in cabinets. The lined hose is constructed so that it can be folded and placed in cabinets in the same manner as unlined hose.

Hose is considered to be unserviceable when it deteriorates to the extent that it can no longer carry water at the required pressure and flow rates. Dry rotted linen or hemp hose, cross threaded couplings, and punctured hose are examples of unserviceable hose.

6. Nozzles. Variable stream nozzles can provide useful variations in water flow and spray patterns during fire fighting operations and they are recommended for employee use. It is recommended that 100 psi (700kPa) nozzle pressure be used to provide good flow patterns for variable stream nozzles. The most desirable attribute for nozzles is the ability of the nozzle person to shut off the water flow at the nozzle when it is necessary. This can be accomplished in many ways. For example, a shutoff nozzle with a lever or rotation of the nozzle to stop flow would be effective, but in other cases a simple globe valve placed between a straight stream nozzle and the hose could serve the same purpose. For straight stream nozzles 50 psi nozzle pressure is recommended. The intent of this standard is to protect the employee from "runaway" hoses if it becomes necessary to drop a pressurized hose line and retreat from the fire front and other related hazards.

7. Design and installation. Standpipe and hose systems designed and installed in accordance with NFPA Standard No. 14, "Standpipe and Hose Systems," are considered to be in compliance with this standard.

§1910.159 Automatic Sprinkler Systems.

1. Scope and application. This section contains the minimum requirements for design, installation and maintenance of sprinkler systems that are needed for employee safety. The Occupational Safety and Health Administration is aware of the fact that the National Board of Fire Underwriters is no longer an active organization, however, sprinkler systems still exist that were designed and installed in accordance with that organization's standards. Therefore, OSHA will recognize sprinkler systems designed to, and maintained in accordance with, NBFU and earlier NFPA standards.

2. Exemptions. In an effort to assure that employers will continue to use automatic sprinkler systems as the primary fire protection system in workplaces, OSHA is exempting from coverage those systems not required by a particular OSHA standard and which have been installed in workplaces solely for the purpose of protecting property. Many of these types of systems are installed in areas or buildings with little or no employee exposure. An example is those warehouses where employees may enter occasionally to take inventory or move stock. Some employers may choose to shut down those systems which are not specifically required by OSHA rather than upgrade them to comply with the standards. OSHA does not intend to regulate such systems. OSHA only intends to regulate those systems which are installed to comply with a particular OSHA standard.

3. Design. There are two basic types of sprinkler system design. Pipe schedule designed systems are based on pipe schedule tables developed to protect hazards with standard sized pipe, number of sprinklers, and pipe lengths. Hydraulic designed systems are based on an engineered design of pipe size which will produce a given water density or flow rate at any particular point in the system. Either design can be used to comply with this standard.

The National Fire Protection Association's Standard No. 13, "Automatic Sprinkler Systems," contains the tables needed to design and install either type of system. Minimum water supplies, densities, and pipe sizes are given for all types of occupancies.

The employer may check with a reputable fire protection engineering consultant or sprinkler design company when evaluating existing systems or designing a new installation.

With the advent of new construction materials for the manufacture of sprinkler pipe, materials, other than steel have been approved for use as sprinkler pipe. Selection of pipe material should be made on the basis of the type of installation and the acceptability of the material to local fire and building officials where such systems may serve more than one purpose.

Before new sprinkler systems are placed into service, an acceptance test is to be conducted. The employer should invite the installer, designer, insurance representative, and a local fire official to witness the test. Problems found during the test are to be corrected before the system is placed into service.

4. Maintenance. It is important that any sprinkler system maintenance be done only when there is minimal employee exposure to the fire hazard. For example, if repairs or changes to the system are to be made, they should be made during those hours when employees are not working or are not occupying that portion of the workplace protected by the portion of the system which has been shut down.

The procedures for performing a flow test via a main drain test or by the use of an inspector's test valve can be obtained from the employer's fire insurance company or from the National Fire Protection Association's Standard No. 13A, "Sprinkler System, Maintenance."

5. Water supplies. The water supply to a sprinkler system is one of the most important factors an employer should consider when evaluating a system. Obviously, if there is no water supply, the system is useless. Water supplies can be lost for various reasons such as improperly closed valves, excessive demand, broken water mains, and broken fire pumps.

The employer must be able to determine if or when this type of condition exists either by performing a main drain test or visual inspection. Another problem may be an inadequate water supply. For example, a light hazard occupancy may, through rehabilitation or change in tenants, become an ordinary or high hazard occupancy. In such cases, the existing water supply may not be able to provide the pressure or duration necessary for proper protection. Employers must assure that proper design and tests have been made to assure an adequate water supply. These tests can be arranged through the employer's fire insurance carrier or through a local sprinkler maintenance company or through the local fire prevention organization.

Anytime the employer must shut down the primary water supply for a sprinkler system, the standard requires that equivalent protection be provided. Equivalent protection may include a fire watch with extinguishers or hose lines in place and manned, or a secondary water supply such as a tank truck and pump, or a tank or fire pond with fire pumps, to protect the areas where the primary water supply is limited or shut down. The employer may also require evacuation of the workplace and have an emergency action plan which specifies such action.

6. Protection of piping. Piping which is exposed to corrosive atmospheres, either chemical or natural, can become defective to the extent that it is useless. Employers must assure that piping is protected from corrosion by its material of construction, e.g., stainless steel, or by a protective coating, e.g., paint.

7. Sprinklers. When an employer finds it necessary to replace sprinkler system components or otherwise change a sprinkler's design, employer should make a complete fire protection engineering survey of that part of the system being changed. This review should assure that the changes to the system will not alter the effectiveness of the system as it is presently designed. Water supplies, densities and flow characteristics should be maintained.

8. Protection of sprinklers. All components of the system must be protected from mechanical impact damage. This can be achieved with the use of mechanical guards or screens or by locating components in areas where physical contact is impossible or limited.

9. Sprinkler alarms. The most recognized sprinkler alarm is the water motor gong or bell that sounds when water begins to flow through the system. This is not however, the only type of acceptable water flow alarm. Any alarm that gives an indication that water is flowing through the system is acceptable. For example, a siren, a whistle, a flashing light, or similar alerting device which can transmit a signal to the necessary persons would be acceptable. The purpose of the alarm is to alert persons that the system is operating, and that some type of planned action is necessary.

10. Sprinkler spacing. For a sprinkler system to be effective there must be an adequate discharge of water spray from the sprinkler head. Any obstructions which hinder the designed density or spray pattern of the water may create unprotected areas which can cause fire to spread. There are some sprinklers that, because of the system's design, are deflected to specific areas. This type of obstruction is acceptable if the system's design takes it into consideration in providing adequate coverage.

§1910.160 Fixed Extinguishing Systems, General.

1. Scope and application. This section contains the general requirements that are applicable to all fixed extinguishing systems installed to meet OSHA standards. It also applies to those fixed extinguishing systems, generally total flooding, which are not required by OSHA, but which, because of the agent's discharge, may expose employees to hazardous concentrations of extinguishing agents or combustion by-products. Employees who work around fixed extinguishing systems must be warned of the possible hazards associated with the system and its agent. For example, fixed dry chemical extinguishing systems may generate a large enough cloud of dry chemical particles that employees may become visually disoriented. Certain gaseous agents can expose employees to hazardous by-products of combustion when the agent comes into contact with hot metal or other hot surface. Some gaseous agents may be present in hazardous concentrations when the system has totally discharged because an extra rich concentration is necessary to extinguish deep-seated fires. Certain local application systems may be designed to discharge onto the flaming surface of a liquid, and it is possible that the liquid can splatter when hit with the discharging agent. All of these hazards must be determined before the system is placed into operation, and must be discussed with employees.

Based on the known toxicological effects of agents such as carbon tetrachloride and chlorobromomethane, OSHA is not permitting the use of these agents in areas where employees can be exposed to the agent or its side effects. However, chlorobromomethane has been accepted and may be used as an explosion suppression agent in unoccupied spaces. OSHA is permitting the use of this agent only in areas where employees will not be exposed.

2. Distinctive alarm signals. A distinctive alarm signal is required to indicate that a fixed system is discharging. Such a signal is necessary on those systems where it is not immediately apparent that the system is discharging. For example, certain gaseous agents make a loud noise when they discharge. In this case no alarm signal is necessary. However, where systems are located in remote locations or away from the general work area and where it is possible that a system could discharge without anyone knowing that it is doing so, then a distinctive alarm is necessary to warn employees of the hazards that may exist. The alarm can be a bell, gong, whistle, horn, flashing light, or any combination of signals as long as it is identifiable as a discharge alarm.

3. Maintenance. The employer is responsible for the maintenance of all fixed systems, but this responsibility does not preclude the use of outside contractors to do such work. New systems should be subjected to an acceptance test before placed in service. The employer should invite the installer, designer, insurance representative and others to witness the test. Problems found during the test need to be corrected before the system is considered operational.

4. Manual discharge stations. There are instances, such as for mechanical reasons and others, where the standards call for a manual backup activation device. While the location of this device is not specified in the standard, the employer should assume that the device should be located where employees can easily reach it. It could, for example, be located along the main means of egress from the protected area so that employees could activate the system as they evacuate the work area.

5. Personal protective equipment. The employer is required to provide the necessary personal protective equipment to rescue employees who may be trapped in a totally flooded environment which may be hazardous to their health. This equipment would normally include a positive-pressure self-contained breathing apparatus and any necessary first aid equipment. In cases where the employer can assure the prompt arrival of the local fire department or plant emergency personnel which can provide the equipment, this can be considered as complying with the standards.

§1910.161 Fixed Extinguishing Systems, Dry Chemical.

1. Scope and application. The requirements of this section apply only to dry chemical systems. These requirements are to be used in conjunction with the requirements of §1910.160.

2. Maintenance. The employer is responsible for assuring that dry chemical systems will operate effectively. To do this, periodic maintenance is necessary. One test that must be conducted during the maintenance check is one which will determine if the agent has remained free of moisture. If an agent absorbs any moisture, it may tend to cake and thereby clog the system. An easy test for acceptable moisture content is to take a lump of dry chemical from the container and drop it from a height of 4 inches. If the lump crumbles into fine particles, the agent is acceptable.

§1910.162 Fixed Extinguishing Systems, Gaseous Agent.

1. Scope and application. This section applies only to those systems which use gaseous agents. The requirements of §1910.160 also apply to the gaseous agent systems covered in this section.

2. Design concentrations. Total flooding gaseous systems are based on the volume of gas which must be discharged in order to produce a certain designed concentration of gas in an enclosed area. The concentration needed to extinguish a fire depends on several factors including the type of fire hazard and the amount of gas expected to leak away from the area during discharge. At times it is necessary to “super-saturate” a work area to provide for expected leakage from the enclosed area. In such cases, employers must assure that the flooded area has been ventilated before employees are permitted to reenter the work area without protective clothing and respirators.

3. Toxic decomposition. Certain halogenated hydrocarbons will break down or decompose when they are combined with high temperatures found in the fire environment. The products of the decomposition can include toxic elements or compounds. For example, when Halon 1211 is placed into contact with hot metal it will break down and form bromide or fluoride fumes. The employer must find out which toxic products may result from decomposition of a particular agent from the manufacturer, and take the necessary precautions to prevent employee exposure to the hazard.

§1910.163 Fixed Extinguishing Systems, Water Spray and Foam.

1. Scope and application. This section applies to those systems that use water spray or foam. The requirements of §1910.160 also apply to this type of system.

2. Characteristics of foams. When selecting the type of foam for a specific hazard, the employer should consider the following limitations of some foams.

- a. Some foams are not acceptable for use on fires involving flammable gases and liquefied gases with boiling points below ambient workplace temperatures. Other foams are not effective when used on fires involving polar solvent liquids.
- b. Any agent using water as part of the mixture should not be used on fire involving combustible metals unless it is applied under proper conditions to reduce the temperature of burning metal below the ignition temperature. The employer should use only those foams that have been tested and accepted for this application by a recognized independent testing laboratory.
- c. Certain types of foams may be incompatible and break down when they are mixed together.
- d. For fires involving water miscible solvents, employers should use only those foams tested and approved for such use. Regular protein foams may not be effective on such solvents.

Whenever employers provide a foam or water spray system, drainage facilities must be provided to carry contaminated water or foam overflow away from the employee work areas and egress routes. This drainage system should drain to a central impounding area where it can be collected and disposed of properly. Other government agencies may have regulations concerning environmental considerations.

§1910.164 Fire Detection Systems.

1. Installation and restoration. Fire detection systems must be designed by knowledgeable engineers or other professionals, with expertise in fire detection systems and when the systems are installed, there should be an acceptance test performed on the system to insure it operates properly. The manufacturer's recommendations for system design should be consulted. While entire systems may not be approved, each component used in the system is required to be approved. Custom fire detection systems should be designed by knowledgeable fire protection or electrical engineers who are familiar with the workplace hazards and conditions. Some systems may only have one or two individual detectors for a small workplace, but good design and installation is still important. An acceptance test should be performed on all systems, including these smaller systems.

OSHA has a requirement that spare components used to replace those which may be destroyed during an alarm situation be available in sufficient quantities and locations for prompt restoration of the system. This does not mean that the parts or components have to be stored at the workplace. If the employer can assure that the supply of parts is available in the local community or the general metropolitan area of the workplace, then the requirements for storage and availability have been met. The intent is to make sure that the alarm system is fully operational when employees are occupying the workplace, and that when the system operates it can be returned to full service the next day or sooner.

2. Supervision. Fire detection systems should be supervised. The object of supervision is detection of any failure of the circuitry, and the employer should use any method that will assure that the system's circuits are operational. Electrically operated sensors for air pressure, fluid pressure, or electrical circuits, can provide effective monitoring and are the typical types of supervision.

3. Protection of fire detectors. Fire detectors must be protected from corrosion either by protective coatings, by being manufactured from noncorrosive materials or by location. Detectors must also be protected from mechanical impact damage, either by suitable cages or metal guards where such hazards are present, or by locating them above or out of contact with materials or equipment which may cause damage.

4. Number, location, and spacing of detectors. This information can be obtained from the approval listing for detectors or NFPA standards. It can also be obtained from fire protection engineers or consultants or manufacturers of equipment who have access to approval listings and design methods.

§1910.165 Employee Alarm Systems.

1. Scope and application. This section is intended to apply to employee alarm systems used for all types of employee emergencies except those which occur so quickly and at such a rapid rate (e.g., explosions) that any action by the employee is extremely limited following detection.

In small workplaces with 10 or less employees the alarm system can be by direct voice communication (shouting) where any one individual can quickly alert all other employees. Radio may be used to transmit alarms from remote workplaces where telephone service is not available, provided that radio messages will be monitored by emergency services, such as fire, police or others, to insure alarms are transmitted and received.

2. Alarm signal alternatives. In recognition of physically impaired individuals, OSHA is accepting various methods of giving alarm signals. For example, visual, tactile or audible alarm signals are acceptable methods for giving alarms to employees. Flashing lights or vibrating devices can be used in areas where the employer has hired employees with hearing or vision impairments. Vibrating devices, air fans, or other tactile devices can be used where visually and hearing impaired employees work. Employers are cautioned that certain frequencies of flashing lights have been claimed to initiate epileptic seizures in some employees and that this fact should be considered when selecting an alarm device. Two-way radio communications would be most appropriate for transmitting emergency alarms in such workplaces which may be remote or where telephones may not be available.

3. Reporting alarms. Employee alarms may require different means of reporting, depending on the workplace involved. For example, in small workplaces, a simple shout throughout the workplace may be sufficient to warn employees of a fire or other emergency. In larger workplaces, more sophisticated equipment is necessary so that entire plants or high-rise buildings are not evacuated for one small emergency. In remote areas, such as pumping plants, radio communication with a central base station may be necessary. The goal of this standard is to assure that all employees who need to know that an emergency exists can be notified of the emergency. The method of transmitting the alarm should reflect the situation found at the workplace.

Personal radio transmitters, worn by an individual, can be used where the individual may be working such as in a remote location. Such personal radio transmitters shall send a distinct signal and should clearly indicate who is having an emergency, the location, and the nature of the emergency. All radio transmitters need a feedback system to assure that the emergency alarm is sent to the people who can provide assistance.

For multistory buildings or single story buildings with interior walls for subdivisions, the more traditional alarm systems are recommended for these types of workplaces. Supervised telephone or manual fire alarm or pull box stations with paging systems to transmit messages throughout the building is the recommended alarm system. The alarm box stations should be available within a travel distance of 200 feet. Water flow detection on a sprinkler system, fire detection systems (guard's supervisory station) or tour signal (watchman's service), or other related systems may be part of the overall system. The paging system may be used for nonemergency operations provided the emergency messages and uses will have precedence over all other uses of the system.

4. Supervision. The requirements for supervising the employee alarm system circuitry and power supply may be accomplished in a variety of ways. Typically, electrically operated sensors for air pressure, fluid pressure, steam pressure, or electrical continuity of circuitry may be used to continuously monitor the system to assure it is operational and to identify trouble in the system and give a warning signal.

[45 FR 60715, Sept. 12, 1980; 46 FR 24557, May 1, 1981]

Stat. Auth.: ORS 654.025(2) and 656.726(4).

Stats. Implemented: ORS 654.001 through 654.295.

Hist: OR-OSHA Admin. Order 14-1993, f. 8/27/93, ef. 11/1/93.

Appendix B to Subdivision L – National Consensus Standards

The following table contains a cross-reference listing of those current national consensus standards which contains information and guidelines that would be considered acceptable in complying with requirements in the specific sections of Subdivision L.

| Subdiv. L section | National consensus standard |
|-------------------|--|
| 1910.156 | ANSI/NFPA No. 1972; Structural Fire Fighter’s Helmets. ANSI Z88.5 American National Standard, Practice for Respirator Protection for the Fire Service. ANSI/NFPA No. 1971, Protective Clothing for Structural Fire Fighters. NFPA No. 1041, Fire Service Instructor Professional Qualifications. |
| 1910.157 | ANSI/NFPA No. 10, Portable Fire Extinguishers. |
| 1910.158 | ANSI/NFPA No. 18, Wetting Agents. ANSI/NFPA No. 20, Centrifugal Fire Pumps. NFPA No. 21, Steam Fire Pumps. ANSI/NFPA No. 22, Water Tanks. NFPA No. 24, Outside Protection. NFPA No. 26, Supervision of Valves. NFPA No. 13E, Fire Department Operations in Properties Protected by Sprinkler, Standpipe Systems. ANSI/NFPA No. 194, Fire Hose Connections. NFPA No. 197, Initial Fire Attack, Training for. NFPA No. 1231, Water Supplies for Suburban and Rural Fire Fighting. |
| 1910.159 | ANSI-NFPA No. 13, Sprinkler Systems. NFPA No. 13A, Sprinkler Systems, Maintenance. ANSI/NFPA No. 18, Wetting Agents. ANSI/NFPA No. 20, Centrifugal Fire Pumps. ANSI/NFPA No. 22, Water Tanks. NFPA No. 24, Outside Protection. NFPA No. 26, Supervision of Valves. ANSI/NFPA No. 72B, Auxiliary Signaling Systems. NFPA No. 1231, Water Supplies for Suburban and Rural Fire Fighting. |
| 1910.160 | ANSI/NFPA No. 11, Foam Systems. ANSI/NFPA 11A, High Expansion Foam Extinguishing Systems. ANSI/NFPA No. 11B, Synthetic Foam and Combined Agent Systems. ANSI/NFPA No. 12, Carbon Dioxide Systems. ANSI/NFPA No. 12A, Halon 1301 Systems. ANSI/NFPA No. 12B, Halon 1211 Systems. ANSI/NFPA No. 15, Water Spray Systems. ANSI/NFPA 16 Foam-Water Spray Systems. ANSI/NFPA No. 17, Dry Chemical Systems. ANSI/NFPA 69, Explosion Suppression Systems. |
| 1910.161 | ANSI/NFPA No. 11B, Synthetic Foam and Combined Agent Systems. ANSI/NFPA No. 17, Dry Chemical Systems. |
| 1910.162 | ANSI/NFPA No. 12, Carbon Dioxide Systems. ANSI/NFPA No. 12A, Halon 1211 Systems. ANSI/NFPA No. 12B, Halon 1301 Systems. ANSI/NFPA No. 69, Explosion Suppression Systems. |

L FIRE PROTECTION

| Subdiv. L section | National consensus standard |
|--------------------------|--|
| 1910.163 | ANSI/NFPA No. 11, Foam Extinguishing Systems. ANSI/NFPA No. 11A, High Expansion Foam Extinguishing Systems. ANSI/NFPA No. 11B, Synthetic Foam and Combined Agent Systems. ANSI/NFPA No. 15, Water Spray Fixed Systems. ANSI/NFPA No. 16, Foam-Water Spray Systems. ANSI/NFPA No. 18, Wetting Agents. NFPA No. 26, Supervision of Valves. |
| 1910.164 | ANSI/NFPA No. 71, Central Station Signaling Systems. ANSI/NFPA No. 72A, Local Protective Signaling Systems. ANSI/NFPA No. 72B, Auxiliary Signaling Systems. ANSI/NFPA No. 72D, Proprietary Protective Signaling Systems. ANSI/NFPA No. 72E, Automatic Fire Detectors. ANSI/NFPA No. 101, Life Safety Code. |
| 1910.165 | ANSI/NFPA No. 71, Central Station Signaling Systems. ANSI/NFPA No. 72A, Local Protective Signaling Systems. ANSI/NFPA No. 72B, Auxiliary Protective Signaling Systems. ANSI/NFPA No. 72C, Remote Station Protective Signaling Systems. ANSI/NFPA No. 72D, Proprietary Protective Signaling Systems. ANSI/NFPA No. 101, Life Safety Code. |
| Metric Conversion | ANSI/ASTM No. E380, American National Standard for Metric Practice. |

NFPA standards are available from the National Fire Protection Association, Batterymarch Park, Quincy, MA 02269.

ANSI Standards are available from the American National Standards Institute, 1430 Broadway, New York, NY 10018.

[45 FR 60715, Sept. 12, 1980; 58 FR 35309, June 30, 1993]

Stat. Auth.: ORS 654.025(2) and 656.726(4).

Stats. Implemented: ORS 654.001 through 654.295.

Hist: OR-OSHA Admin. Order 14-1993, f. 8/27/93, ef. 11/1/93.

Appendix C to Subdivision L – Fire Protection References for Further Information

I. Appendix general references. The following references provide information which can be helpful in understanding the requirements contained in all of the sections of Subdivision L:

A. Fire Protection Handbook, National Fire Protection Association; Batterymarch Park, Quincy, MA 02269.

B. Accident Prevention Manual for Industrial Operations, National Safety Council; 425 North Michigan Avenue, Chicago, IL 60611.

C. Various associations also publish information which may be useful in understanding these standards. Examples of these associations are: Fire Equipment Manufacturers Association (FEMA) of Arlington, VA 22204 and the National Association of Fire Equipment Distributors (NAFED) of Chicago, IL 60601.

II. Appendix references applicable to individual sections. The following references are grouped according to individual sections contained in Subpart L. These references provide information which may be helpful in understanding and implementing the standards of each section of Subdivision L.

A. §1910.156. Fire brigades:

1. Private Fire Brigades, NFPA 27; National Fire Protection Association, Batterymarch Park, Quincy, MA 02269.

2. Initial Fire Attack, Training Standard On, NFPA 197; National Fire Protection Association, Batterymarch Park, Quincy, MA 02269.

3. Fire Fighter Professional Qualifications, NFPA 1001; National Fire Protection Association, Batterymarch Park, Quincy, MA 02269.

4. Organization for Fire Services, NFPA 1201; National Fire Protection Association, Batterymarch Park, Quincy, MA 02269.

5. Organization of a Fire Department, NFPA 1202; National Fire Protection Association, Batterymarch Park, Quincy, MA 02269.

6. Protective Clothing for Structural Fire Fighting, ANSI/NFPA 1971; National Fire Protection Association, Batterymarch Park, Quincy, MA 02269.

7. American National Standard for Men's Safety-Toe Footwear, ANSI Z41.1; American National Standards Institute, New York, NY 10018.

8. American National Standard for Occupational and Educational Eye and Face Protection, ANSI Z87.1; American National Standards Institute, New York, NY 10018.

L FIRE PROTECTION

9. American National Standard, Safety Requirements for Industrial Head Protection, ANSI Z89.1; American National Standards Institute, New York, NY 10018.
10. Specifications for Protective Headgear for Vehicular Users, ANSI Z90.1; American National Standards Institute, New York, NY 10018.
11. Testing Physical Fitness; Davis and Santa Maria. Fire Command. April 1975.
12. Development of a Job-Related Physical Performance Examination for Fire Fighters; Dotson and Others. A summary report for the National Fire Prevention and Control Administration. Washington, DC. March 1977.
13. Proposed Sample Standards for Fire Fighters' Protective Clothing and Equipment; International Association of Fire Fighters, Washington, DC.
14. A Study of Facepiece Leakage of Self-Contained Breathing Apparatus by DOP Man Tests; Los Alamos Scientific Laboratory, Los Alamos, NM.
15. The Development of Criteria for Fire Fighters' Gloves; Vol. II: Glove Criteria and Test Methods; National Institute for Occupational Safety and Health, Cincinnati, OH. 1976.
16. Model Performance Criteria for Structural Fire Fighters' Helmets; National Fire Prevention and Control Administration, Washington, DC. 1977.
17. Firefighters; Job Safety and Health Magazine, Occupational Safety and Health Administration, Washington, DC. June 1978.
18. Eating Smoke – The Dispensable Diet; Utech, H.P. The Fire Independent, 1975.
19. Project Monoxide – A Medical Study of an Occupational Hazard of Fire Fighters; International Association of Fire Fighters, Washington, DC.
20. Occupational Exposures to Carbon Monoxide in Baltimore Firefighters; Radford and Levine. Johns Hopkins University, Baltimore, MD. Journal of Occupational Medicine, September, 1976.
21. Fire Brigades; National Safety Council, Chicago, IL. 1966.
22. American National Standard, Practice for Respiratory Protection for the Fire Service; ANSI Z88.5; American National Standards Institute, New York, NY 10018.
23. Respirator Studies for the Nuclear Regulatory Commission; October 1, 1977-September 30, 1978. Evaluation and Performance of Open Circuit Breathing Apparatus. NU REG/CR1235. Los Alamos Scientific Laboratory; Los Alamos, NM. 87545, January, 1980.

B. §1910.157. Portable fire extinguishers:

1. Standard for Portable Fire Extinguishers, ANSI/NFPA 10; National Fire Protection Association, Batterymarch Park, Quincy, MA 02269.
2. Methods for Hydrostatic Testing of Compressed Gas Cylinders, C-1; Compressed Gas Association, 1235 Jefferson Davis Highway, Arlington, VA 22202.
3. Recommendations for the Disposition of Unserviceable Compressed Gas Cylinders, C-2; Compressed Gas Association, 1235 Jefferson Davis Highway, Arlington, VA 22202.
4. Standard for Visual Inspection of Compressed Gas Cylinders, C-6; Compressed Gas Association, 1235 Jefferson Davis Highway, Arlington, VA 22202.
5. Portable Fire Extinguisher Selection Guide, National Association of Fire Equipment Distributors; 111 East Wacker Drive, Chicago, IL 60601.

C. §1910.158. Standpipe and hose systems:

1. Standard for the Installation of Sprinkler Systems, ANSI/NFPA 13; National Fire Protection Association, Batterymarch Park, Quincy, MA 02269.
2. Standard of the Installation of Standpipe and Hose Systems, ANSI/NFPA 14; National Fire Protection Association, Batterymarch Park, Quincy, MA 02269.
3. Standard for the Installation of Centrifugal Fire Pumps, ANSI/NFPA 20; National Fire Protection Association, Batterymarch Park, Quincy, MA 02269.
4. Standard for Water Tanks for Private Fire Protection, ANSI/NFPA 22; National Fire Protection Association, Batterymarch Park, Quincy, MA 02269.
5. Standard for Screw Threads and Gaskets for Fire Hose Connections, ANSI/NFPA 194; National Fire Protection Association, Batterymarch Park, Quincy, MA 02269.
6. Standard for Fire Hose, NFPA 196; National Fire Protection Association, Batterymarch Park, Quincy, MA 02269.
7. Standard for the Care of Fire Hose, NFPA 198; National Fire Protection Association, Batterymarch Park, Quincy, MA 02269.

D. §1910.159. Automatic sprinkler systems:

1. Standard of the Installation of Sprinkler Systems, ANSI-NFPA 13; National Fire Protection Association, Batterymarch Park, Quincy, MA 02269.
2. Standard for the Care and Maintenance of Sprinkler Systems, ANSI/NFPA 13A; National Fire Protection Association, Batterymarch Park, Quincy, MA 02269.

3. Standard for the Installation of Standpipe and Hose Systems, ANSI/NFPA 14; National Fire Protection Association, Batterymarch Park, Quincy, MA 02269.
4. Standard for the Installation of Centrifugal Fire Pumps, ANSI/NFPA 20; National Fire Protection Association, Batterymarch Park, Quincy, MA 02269.
5. Standard for Water Tanks for Private Fire Protection, ANSI-NFPA 22; National Fire Protection Association, Batterymarch Park, Quincy, MA 02269.
6. Standard for Indoor General Storage, ANSI/NFPA 231; National Fire Protection Association, Batterymarch Park, Quincy, MA 02269.
7. Standard for Rack Storage of Materials, ANSI/NFPA 231C; National Fire Protection Association, Batterymarch Park, Quincy, MA 02269.

E. §1910.160. Fixed extinguishing systems – general information:

1. Standard for Foam Extinguishing Systems, ANSI-NFPA 11; National Fire Protection Association, Batterymarch Park, Quincy, MA 02269.
2. Standard for Hi-Expansion Foam Systems, ANSI/NFPA 11A; National Fire Protection Association, Batterymarch Park, Quincy, MA 02269.
3. Standard on Synthetic Foam and Combined Agent Systems, ANSI/NFPA 11B; National Fire Protection Association, Batterymarch Park, Quincy, MA 02269.
4. Standard on Carbon Dioxide Extinguishing Systems, ANSI/NFPA 12; National Fire Protection Association, Batterymarch Park, Quincy, MA 02269.
5. Standard on Halon 1301, ANSI/NFPA 12A; National Fire Protection Association, Batterymarch Park, Quincy, MA 02269.
6. Standard on Halon 1211, ANSI/NFPA 12B; National Fire Protection Association, Batterymarch Park, Quincy, MA 02269.
7. Standard for Water Spray Systems, ANSI/NFPA 15; National Fire Protection Association, Batterymarch Park, Quincy, MA 02269.
8. Standard for Foam-Water Sprinkler Systems and Foam-Water Spray Systems, ANSI/NFPA 16; National Fire Protection Association, Batterymarch Park, Quincy, MA 02269.
9. Standard for Dry Chemical Extinguishing Systems, ANSI/NFPA 17; National Fire Protection Association, Batterymarch Park, Quincy, MA 02269.

F. §1910.161. Fixed extinguishing systems – dry chemical:

1. Standard for Dry Chemical Extinguishing Systems, ANSI/NFPA 17; National Fire Protection Association, Batterymarch Park, Quincy, MA 02269.

2. National Electrical Code, ANSI/NFPA 70; National Fire Protection Association, Batterymarch Park, Quincy, MA 02269.

3. Standard for the Installation of Equipment for the Removal of Smoke and Grease-Laden Vapor from Commercial Cooking Equipment, NFPA 96; National Fire Protection Association, Batterymarch Park, Quincy, MA 02269.

G. §1910.162. Fixed extinguishing systems – gaseous agents:

1. Standard on Carbon Dioxide Extinguishing Systems, ANSI/NFPA 12; National Fire Protection Association, Batterymarch Park, Quincy, MA 02269.

2. Standard on Halon 1301, ANSI/NFPA 12B; National Fire Protection Association, Batterymarch Park, Quincy, MA 02269.

3. Standard on Halon 1211, ANSI/NFPA 12B; National Fire Protection Association, Batterymarch Park, Quincy, MA 02269.

4. Standard on Explosion Prevention Systems, ANSI/NFPA 69; National Fire Protection Association, Batterymarch Park, Quincy, MA 02269.

5. National Electrical Code, ANSI/NFPA 70; National Fire Protection Association, Batterymarch Park, Quincy, MA 02269.

6. Standard on Automatic Fire Detectors, ANSI/NFPA 72E; National Fire Protection Association, Batterymarch Park, Quincy, MA 02269.

7. Determination of Halon 1301/1211 Threshold Extinguishing Concentrations Using the Cup Burner Method; Riley and Olson, Ansul Report AL-530-A.

H. §1910.163. Fixed extinguishing systems – water spray and foam agents:

1. Standard for Foam Extinguisher Systems, ANSI/NFPA 11; National Fire Protection Association, Batterymarch Park, Quincy, MA 02269.

2. Standard for High Expansion Foam Systems, ANSI/NFPA 11A; National Fire Protection Association, Batterymarch Park, Quincy, MA 02269.

3. Standard for Water Spray Fixed Systems for Fire Protection, ANSI/NFPA 15; National Fire Protection Association, Batterymarch Park, Quincy, MA 02269.

4. Standard for the Installation of Foam-Water Sprinkler Systems and Foam-Water Spray Systems, ANSI/NFPA 16; National Fire Protection Association, Batterymarch Park, Quincy, MA 02269.

I. §1910.164. Fire Detection systems:

1. National Electrical Code, ANSI/NFPA 70; National Fire Protection Association, Batterymarch Park, Quincy, MA 02269.

2. Standard for Central Station Signaling Systems, ANSI/NFPA 71; National Fire Protection Association, Batterymarch Park, Quincy, MA 02269.
3. Standard on Automatic Fire Detectors, ANSI/NFPA 72E; National Fire Protection Association, Batterymarch Park, Quincy, MA 02269.

J. §1910.165. Employee alarm systems:

1. National Electrical Code, ANSI/NFPA 70; National Fire Protection Association, Batterymarch Park, Quincy, MA 02269.
2. Standard for Central Station Signaling systems, ANSI/NFPA 71; National Fire Protection Association, Batterymarch Park, Quincy, MA 02269.
3. Standard for Local Protective Signaling Systems, ANSI/NFPA 72A; National Fire Protection Association, Batterymarch Park, Quincy, MA 02269.
4. Standard for Auxiliary Protective Signaling Systems, ANSI/NFPA 72B; National Fire Protection Association, Batterymarch Park, Quincy, MA 02269.
5. Standard for Remote Station Protective Signaling Systems, ANSI/NFPA 72C; National Fire Protection Association, Batterymarch Park, Quincy, MA 02269.
6. Standard for Proprietary Protective Signaling Systems, ANSI/NFPA 72D; National Fire Protection Association, Batterymarch Park, Quincy, MA 02269.
7. Vocal Emergency Alarms in Hospitals and Nursing Facilities: Practice and Potential. National Bureau of Standards. Washington, D.C., July 1977.
8. Fire Alarm and Communication Systems. National Bureau of Standards. Washington, D.C., April 1978.

[45 FR 60715, Sept. 12, 1980; 58 FR 35309, June 30, 1993]

Stat. Auth.: ORS 654.025(2) and 656.726(4).

Stats. Implemented: ORS 654.001 through 654.295.

Hist: OR-OSHA Admin. Order 14-1993, f. 8/27/93, ef. 11/1/93.

Appendix D to Subdivision L – Availability of Publications Incorporated by Reference in Section 1910.156, Fire Brigades

The final standard for fire brigades, Section 1910.156, contains provisions which incorporate certain publications by reference. The publications provide criteria and test methods for protective clothing worn by those fire brigade members who are expected to perform interior structural fire fighting. The standard references the publications as the chief sources of information for determining if the protective clothing affords the required level of protection.

It is appropriate to note that the final standard does not require employers to purchase a copy of the referenced publications. Instead, employers can specify (in purchase orders to the manufacturers) that the protective clothing meet the criteria and test methods contained in the referenced publications and can rely on the manufacturers' assurances of compliance. Employers, however, may desire to obtain a copy of the referenced publications for their own information.

The paragraph designation of the standard where the referenced publications appear, the title of the publications, and the availability of the publications are as follows:

| Paragraph designation | Referenced Publication | Available From |
|-----------------------|--|--|
| 1910.156(e)(3)(ii) | "Protective Clothing for Structural Fire Fighting," NFPA No. 1971 (1975) | National Fire Protection Association, Batterymarch Park, Quincy MA 02269. |
| 1910.156(e)(4)(i) | "Development of Criteria for Fire Fighter's Gloves; Vol. II, Part II: Test Methods" (1976) | U.S. Government Printing Office, Washington, D.C. 20402. Stock No. for Vol. II is: 071-033-0201-1. |
| 1910.156(e)(5)(i) | "Model Performance Criteria for Structural Firefighter's Helmets" (1977) | U.S. Fire Administration, National Fire Safety and Research Office, Washington, D.C. 20230. |

The referenced publications (or a microfiche of the publications) are available for review at many universities and public libraries throughout the country. These publications may also be examined at the OSHA Technical Data Center, Room N2439-Rear, United States Department of Labor, 200 Constitution Ave NW, Washington, DC 20210 (202-219-7500), or at any OSHA Regional Office (see telephone directories under United States Government – Labor Department).

[45 FR 60715, Sept. 12, 1980; 58 FR 35309, June 30, 1993]

Stat. Auth.: ORS 654.025(2) and 656.726(4).

Stats. Implemented: ORS 654.001 through 654.295.

Hist: OR-OSHA Admin. Order 14-1993, f. 8/27/93, ef. 11/1/93.
OR-OSHA Admin. Order 4-1997, f. 4/2/97, ef. 4/2/97.

Appendix E to Subdivision L – Test Methods for Protective Clothing

This appendix contains test methods which must be used to determine if protective clothing affords the required level of protection as specified in §1910.156, fire brigades.

(1) Puncture resistance test method for foot protection.

A. Apparatus. The puncture resistance test shall be performed on a testing machine having a movable platform adjusted to travel at 1/4-inch/min (0.1 cm/sec). Two blocks of hardwood, metal, or plastic shall be prepared as follows: the blocks shall be of such size and thickness as to insure a suitable rigid test ensemble and allow for at least 1-inch of the pointed end of an 8D nail to be exposed for the penetration. One block shall have a hole drilled to hold an 8D common nail firmly at an angle of 98 degrees. The second block shall have a maximum 1/2-inch (1.3 cm) diameter hole drilled through it so that the hole will allow free passage of the nail after it penetrates the insole during the test.

B. Procedure. The test ensemble consisting of the sample unit, the two prepared blocks, a piece of leather outsole 10 to 11 irons thick, and a new 8D nail, shall be placed as follows: the 8D nail in the hole, the sample of outsole stock super-imposed above the nail, the area of the sole plate to be tested placed on the outsole, and the second block with hole so placed as to allow for free passage of the nail after it passes through the outsole stock and sole plate in that order. The machine shall be started and the pressure, in pounds required for the nail to completely penetrate the outsole and sole plate, recorded to the nearest 5 pounds. Two determinations shall be made on each sole plate and the results averaged. A new nail shall be used for each determination.

C. Source. These test requirements are contained in "Military Specification For Fireman's Boots," MIL-B-2885D (1973 and amendment dated 1975) and are reproduced for your convenience.

(2) Test method for determining the strength of cloth by tearing: Trapezoid Method.

A. Test specimen. The specimen shall be a rectangle of cloth 3 inches by 6 inches (7.6 cm by 15.2 cm). The long dimension shall be parallel to the warp for warp tests and parallel to the filling for filling tests. No two specimens for warp tests shall contain the same warp yarns, nor shall any two specimens for filling tests contain the same filling yarns. The specimen shall be taken no nearer the selvage than 1/10 the width of the cloth. An isosceles trapezoid having an altitude of 3 inches (7.6 cm) and bases of 1-inch (2.5 cm) and 4 inches (10.2 cm) in length, respectively, shall be marked on each specimen, preferably with the aid of a template. A cut approximately 3/8-inch (1 cm) in length shall then be made in the center of a perpendicular to the 1-inch (2.5 cm) edge.

B. Apparatus.

(i) Six-ounce (.17 kg) weight tension clamps shall be used so designed that the 6 ounces (.17 kg) of weight are distributed evenly across the complete width of the sample.

(ii) The machine shall consist of three main parts: Straining mechanism, clamps for holding specimen, and load and elongation recording mechanisms.

(iii) A machine wherein the specimen is held between two clamps and strained by a uniform movement of the pulling clamp shall be used.

(iv) The machine shall be adjusted so that the pulling clamp shall have a uniform speed of 12 ± 10.5 inches per minute ($0.5 \pm .02$ cm/sec).

(v) The machine shall have two clamps with two jaws on each clamp. The design of the two clamps shall be such that one gripping surface or jaw may be an integral part of the rigid frame of the clamp or be fastened to allow a slight vertical movement, while the other gripping surface or jaw shall be completely moveable. The dimension of the immovable jaw of each clamp parallel to the application of the load shall measure 1-inch, and the dimension of the jaw perpendicular to this direction shall measure 3 inches or more. The face of the movable jaw of each clamp shall measure 1-inch by 3 inches.

Each jaw face shall have a flat smooth, gripping surface. All edges which might cause a cutting action shall be rounded to a radius of not over 1/64-inch (.04 cm). In cases where a cloth tends to slip when being tested, the jaws may be faced with rubber or other material to prevent slippage. The distance between the jaws (gage length) shall be 1-inch at the start of the test.

(vi) Calibrated dial; scale or chart shall be used to indicate applied load and elongation. The machine shall be adjusted or set, so that the maximum load required to break the specimen will remain indicated on the calibrated dial or scale after the test specimen has ruptured.

(vii) The machine shall be of such capacity that the maximum load required to break the specimen shall be not greater than 85 percent or less than 15 percent of the rated capacity.

(viii) The error of the machine shall not exceed 2 percent up to and including a 50-pound load (22.6 kg) and 1 percent over a 50-pound load (22.6 kg) at any reading within its loading range.

(ix) All machine attachments for determining maximum loads shall be disengaged during this test.

C. Procedure.

(i) The specimen shall be clamped in the machine along the nonparallel sides of the trapezoid so that these sides lie along the lower edge of the upper clamp and the upper edge of the lower clamp with the cut halfway between the clamps. The short trapezoid base shall be held taut and the long trapezoid base shall lie in the folds.

(ii) The machine shall be started and the force necessary to tear the cloth shall be observed by means of an autographic recording device. The speed of the pulling clamp shall be 12 inches \pm 0.5-inch per minute ($0.5 \pm .02$ cm/sec).

(iii) If a specimen slips between the jaws, breaks in or at the edges of the jaws, or if for any reason attributable to faulty technique, an individual measurement falls markedly below the average test results for the sample unit, such result shall be discarded and another specimen shall be tested.

(iv) The tearing strength of the specimen shall be the average of the five highest peak loads of resistance registered for 3 inches (7.6 cm) of separation of the tear.

D. Report.

(i) Five specimens in each of the warp and filling directions shall be tested from each sample unit.

(ii) The tearing strength of the sample unit shall be the average of the results obtained from the specimens tested in each of the warp and filling directions and shall be reported separately to the nearest 0.1-pound (.05 kg).

E. Source. These test requirements are contained in "Federal Test Method Standard 191, Method 5136" and are reproduced for your convenience.

(3) Test method for determining flame-resistance of cloth; vertical.

A. Test specimen. The specimen shall be a rectangle of cloth 2 3/4 inches (7.0 cm) by 12 inches (30.5 cm) with the long dimension parallel to either the warp or filling direction of the cloth. No two warp specimens shall contain the same warp yarns, and no two filling specimens shall contain the same filling yarn.

B. Number of determinations. Five specimens from each of the warp and filling directions shall be tested from each sample unit.

C. Apparatus.

(i) **Cabinet.** A cabinet and accessories shall be fabricated in accordance with the requirements specified in Figures L-1, L-2, and L-3. Galvanized sheet metal or other suitable metal shall be used. The entire inside back wall of the cabinet shall be painted black to facilitate the viewing of the test specimen and pilot flame.

(ii) **Burner.** The burner shall be equipped with a variable orifice to adjust the flame height, a barrel having a 3/8-inch (1 cm) inside diameter and a pilot light.

(a) The burner may be constructed by combining a 3/8-inch (1 cm) inside diameter barrel $3 \pm 1/4$ inches ($7.6 \pm .6$ cm) long from a fixed orifice burner with a base from a variable orifice burner.

L FIRE PROTECTION

- (b) The pilot light tube shall have a diameter of approximately 1/16-inch (.2 cm) and shall be spaced 1/8-inch (.3 cm) away from the burner edge with a pilot flame 1/8-inch (.3 cm) long.
- (c) The necessary gas connections and the applicable plumbing shall be as specified in Figure L-4 except that a solenoid valve may be used in lieu of the stopcock valve to which the burner is attached. The stopcock valve or solenoid valve, whichever is used, shall be capable of being fully opened or fully closed in 0.1-second.
- (d) On the side of the barrel of the burner, opposite the pilot light there shall be a metal rod of approximately 1/8-inch (.3 cm) diameter spaced 1/2-inch (1.3 cm) from the barrel and extending above the burner. The rod shall have two 5/16-inch (.8 cm) prongs marking the distances of 3/4-inch (1.9 cm) and 1 1/2 inches (3.8 cm) above the top of the burner.
- (e) The burner shall be fixed in a position so that the center of the barrel of the burner is directly below the center of the specimen.
- (iii) There shall be a control valve system with a delivery rate designed to furnish gas to the burner under a pressure of $2 \frac{1}{2} \pm \frac{1}{4}$ (psi) (17.5 ± 1.8 kPa) per square inch at the burner inlet (see (g)(3)(vi)(A)). The manufacturer's recommended delivery rate for the valve system shall be included in the required pressure.
- (iv) A synthetic gas mixture shall be of the following composition within the following limits (analyzed at standard conditions): 55 ± 3 percent hydrogen, 24 ± 1 percent methane, 3 ± 1 percent ethane, and 18 ± 1 percent carbon monoxide which will give a specific gravity of 0.365 ± 0.018 (air = 1) and a B.T.U. content of 540 ± 20 per cubic foot (20.1 ± 3.7 kJ/L)(dry basis) at 69.8 degrees F (21 degrees C).
- (v) There shall be metal hooks and weights to produce a series of total loads to determine length of char. The metal hooks shall consist of No. 19 gage steel wire or equivalent and shall be made from 3-inch (7.6 cm) lengths of wire and bent 1/2-inch (1.3 cm) from one end to a 45 degree hook. One end of the hook shall be fastened around the neck of the weight to be used.
- (vi) There shall be a stop watch or other device to measure the burning time to 0.2-second.
- (vii) There shall be a scale, graduated in 0.1-inch (.3 cm) to measure the length of char.

D. Procedure.

- (i) The material undergoing test shall be evaluated for the characteristics of after-flame time and char length on each specimen.

(ii) All specimens to be tested shall be at moisture equilibrium under standard atmospheric conditions in accordance with paragraph (3)C of this appendix. Each specimen to be tested shall be exposed to the test flame within 20 seconds after removal from the standard atmosphere. In case of dispute, all testing will be conducted under Standard Atmospheric Conditions in accordance with paragraph (3)C of this appendix.

(iii) The specimen in its holder shall be suspended vertically in the cabinet in such a manner that the entire length of the specimen is exposed and the lower end is 3/4-inch (1.9 cm) above the top of the gas burner. The apparatus shall be set up in a draft free area.

(iv) Prior to inserting the specimen, the pilot flame shall be adjusted to approximately 1/8-inch (.3 cm) in height measured from its lowest point to the tip.

The burner flame shall be adjusted by means of the needle valve in the base of the burner to give a flame height of 1 1/2 inches (3.8 cm) with the stopcock fully open and the air supply to the burner shut off and taped. The 1 1/2-inch (3.8 cm) flame height is obtained by adjusting the valve so that the uppermost portion (tip) of the flame is level with the tip of the metal prong (see Figure L-2) specified for adjustment of flame height. It is an important aspect of the evaluation that the flame height be adjusted with the tip of the flame level with the tip of the metal prong. After inserting the specimen, the stopcock shall be fully opened, and the burner flame applied vertically at the middle of the lower edge of the specimen for 12 seconds and the burner turned off. The cabinet door shall remain shut during testing.

(v) The afterflame shall be the time the specimen continues to flame after the burner flame is shut off.

(vi) After each specimen is removed, the test cabinet shall be cleared of fumes and smoke prior to testing the next specimen.

(vii) After both flaming and glowing have ceased, the char length shall be measured. The char length shall be the distance from the end of the specimen, which was exposed to the flame, to the end of a tear (made lengthwise) of the specimen through the center of the charred area as follows: The specimen shall be folded lengthwise and creased by hand along a line through the highest peak of the charred area. The hook shall be inserted in the specimen (or a hole, 1/4-inch (.6 cm) diameter or less, punched out for the hook) at one side of the charred area 1/4-inch (.6 cm) from the adjacent outside edge and 1/4-inch (.6 cm) in from the lower end. A weight of sufficient size such that the weight and hook together shall equal the total tearing load required in Table L-2 of this section shall be attached to the hook.

(viii) A tearing force shall be applied gently to the specimen by grasping the corner of the cloth at the opposite edge of the char from the load and raising the specimen and weight clear of the supporting surface. The end of the tear shall be marked off on the edge and the char length measurement made along the undamaged edge.

L FIRE PROTECTION

Loads for determining char length applicable to the weight of the test cloth shall be as shown in Table L-2.

Table L-2¹

| Specified weight per square yard of cloth before any fire retardant treatment or coating – ounces | Total tearing weight for determining the charred length – pound |
|---|---|
| 2.0 to 6.0..... | 0.25 |
| Over 6.0 to 15.0..... | 0.50 |
| Over 15.0 to 23.0..... | 0.75 |
| Over 23.0..... | 1.00 |

¹ To change into S.I. (System International) units, 1-ounce = 28.35 grams, 1-pound = 453 grams, 1-yard = .91 meter.

(ix) The afterflame time of the specimen shall be recorded to the nearest 0.2-second and the char length to the nearest 0.1-inch (.3 cm).

E. Report.

(i) The afterflame time and char length of the sample unit shall be the average of the results obtained from the individual specimens tested. All values obtained from the individual specimens shall be recorded.

(ii) The afterflame time shall be reported to the nearest 0.2-second and the char length to the nearest 0.1-inch (.3 cm).

F. Source. These test requirements are contained in “Federal Test Method Standard 191, Method 5903 (1971)” and are reproduced for your convenience.

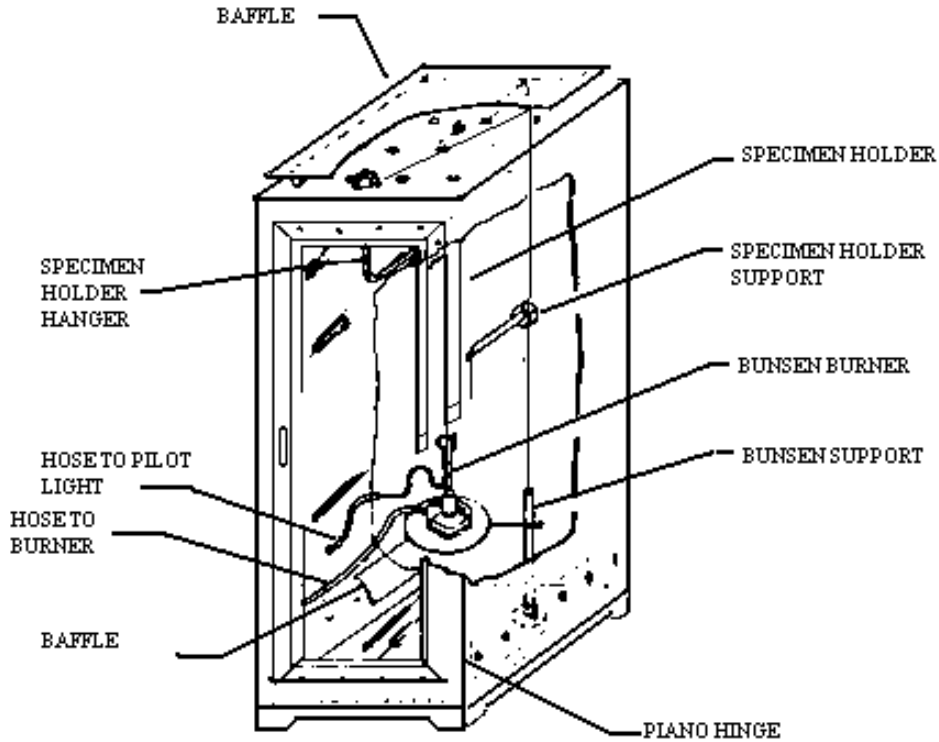

Figure L-1 – Vertical flame-resistance textile apparatus. All given dimensions are in inches. System International (S. I.) Unit: 1-inch = 2.54 cm.

L FIRE PROTECTION

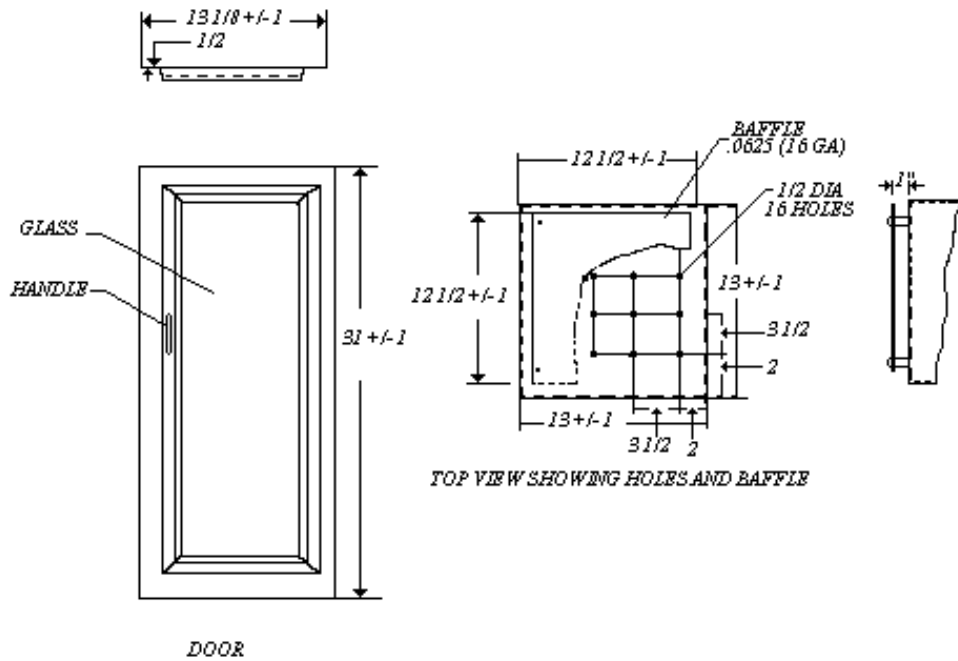

Figure L-2 - Vertical flame-resistance textile apparatus, door and top view w/baffle. All given dimensions are in inches. System International (S. I.) Unit: 1-inch = 2.54 cm.

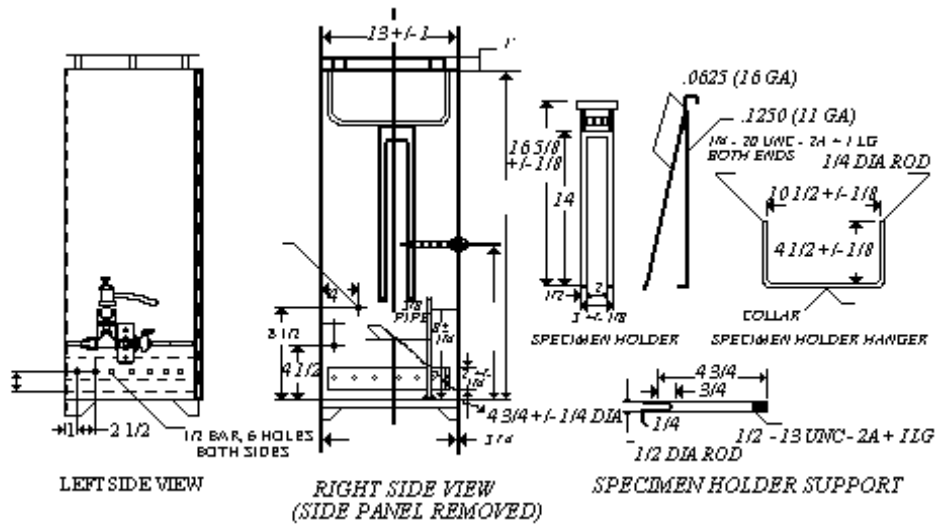
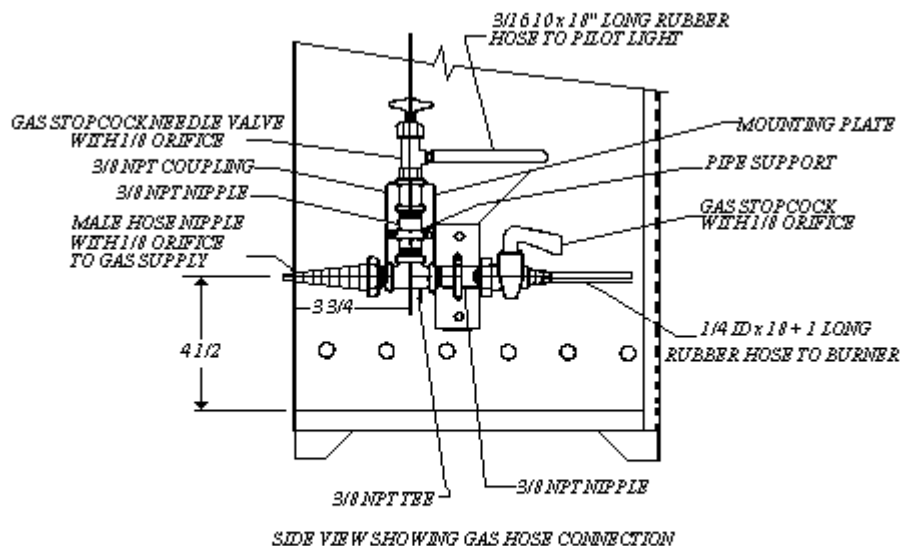

Figure L-3 – Vertical flame-resistance textile apparatus, view and details. All given dimensions are in inches. System International (S. I.) Unit: 1-inch = 2.54 cm.

L FIRE PROTECTION



NOTE:
ALL PIPE FITTINGS TO BE
BLACK IRON PIPE

Figure L-4 – Vertical flame-resistance textile apparatus. All given dimensions are in inches. System International (S. I.)
Unit: 1-inch = 2.54 cm.

[45 FR 60715, Sept. 12, 1980; 46 FR 24557, May 1, 1981]

Stat. Auth.: ORS 654.025(2) and 656.726(4).

Stats. Implemented: ORS 654.001 through 654.295.

Hist: OR-OSHA Admin. Order 14-1993, f. 8/27/93, ef. 11/1/93

– END OF DOCUMENT –