

**Historic Columbia River Highway
Advisory Committee Meeting**

Meeting will be Hybrid
Troutdale Sheriff's Office, Kellogg Room
234 SW Kendall Ct, Troutdale, OR 97060
Login online: <https://tinyurl.com/AC-Dec2023>



Meeting ID: 822 8060 3670
Password: HCRHAC

Call in (does not require internet): 1 (253) 215-8782
Meeting ID: # 822 8060 3670

Thursday, December 7th, 2023

10 AM – 2:00 PM Advisory Committee Meeting

MEMBERS:

Arthur Babitz, Chair
Leti Valle Moretti
Ernie Drapela, Vice-Chair
Tricia Forsi
Judy Davis
Lisa Farquharson
Clay Courtright
Rian Windsheimer
Kate Baumgartner
Chrissy Curran

Hood River County Representative
Hood River County Governor's Representative
Multnomah County Governor's Representative
Multnomah County Representative
Wasco County Representative
Wasco County Governor's Representative
Oregon Parks and Recreation Department
Oregon Department of Transportation
Travel Oregon
State Historic Preservation Office

AGENDA:

Time	Agenda Topics	Presenter
10:00 AM	Call to Order	Arthur Babitz, Chair
10:05 AM	Opportunity for the public to comment on any item not on the agenda*	
10:10 AM	Approval of Minutes	Arthur Babitz, Chair
10:15 AM	Signage/sharrows on Rock Creek Rd in Mosier	Dan Shannahan, ODOT
10:40 AM	Mitchell Point Tunnel Update	Austin Armstrong, FHWA
11:10 AM	State Trail Consistency Report (Review in advance)	Wayne Stewart, Jeanette Kloos
11:45 AM	Year in Review	Terra
12:00 PM	Lunch Break	
12:45 PM	2024 Workplan	Terra/Committee

1:05 PM	Mitchell Point Tunnel Opening Celebration Discussion <ul style="list-style-type: none"> • Desired Outcome • Priorities • Messaging 	All
1:25 PM	Updates <ul style="list-style-type: none"> • ODOT <ul style="list-style-type: none"> ○ OTC presentation and resolution ○ Multnomah Falls Viaducts Update • Next meetings: <ul style="list-style-type: none"> ○ March 21, 2024 ○ June 20, 2024 ○ September 19, 2024 ○ December 12, 2024 • Friends of the Historic Highway • OPRD • Travel Oregon • USFS • WFLHD 	Terra, Jeanette, Clay, Kate, Donna, Matt
1:50 PM	Committee Round Table	All
2:00 PM	Adjourn	

March Agenda items

- Mitchell Point Opening
- Summer 2024 Congestion

Historic Columbia River Highway Advisory Committee 2023 Work Plan

1. **The Final 1.5 Miles of Engineering**
2. **Mitchell Point to Hood River State Trail funding**
3. **Multnomah Falls Viaducts Railroad Coordination**
4. **Columbia Gorge Express**
5. **Eagle Creek Stairway Replacement**
6. **Waterfall Corridor Visitor Experience Management**
7. Congestion and Safety Plan Implementation Projects
8. Twin Tunnels Safety Improvements Implementation
9. Historic Guardrail Research/Analysis
10. Larch Mountain Slide – Funding

Historic Columbia River Highway Advisory Committee Meeting Summary

September 21, 2023

Hybrid – Zoom and Cousins Country Inn

Members Attending:	Ernie Drapela, Vice Chair Judy Davis Tricia Forsi David Spangler, OPRD Marc Berry, Member Emeritus Chris Ford (ODOT)
Historic Highway AC Staff:	Terra Lingley (ODOT) Melissa Brown (ODOT) Katelyn Jackson (ODOT)
Others Attending:	Jeanette Kloos Bob Hadlow (ODOT) Kent Klasch (ODOT) Richard Alfieri Bonnie Clark Kaylee Crosby Paul Wilcox Jennifer O'Donnell Jamen Lee (OPRD) Sandra Hikari (ODOT) Armando Zelada Kent Krumpschmidt, Sasquatch Shuttle Everyday Northwest Frank Stevens Austin Armstrong (WFLHD) Jeanette Kloos Dick Weber Dan Shanahan (ODOT) David Duncan Van Smith

Call to Order

Ernie called to order the meeting at 10:00.

Public Comment

Ernie- Letter from Kathy Watson regarding maintenance on the trail was included in this meeting's packet. Friends of the Historic Highway does a lot of the upkeep on the trail, especially during the winter months. It would be good to follow up on.

David Spangler (OPRD)- has never seen this letter, as OPRD, it would be good to see this. He said that they have worked on these issues and would be happy to follow up regarding the maintenance.

Jeannette Kloos (Friends of the Historic Highway) - Spoke on doing work parties using nonskilled labor to do those. She gets info from trail keepers of Oregon. They can do more skilled labor then the group can do.

Kent Kalsch (ODOT)- also hasn't seen the letter - maintenance cannot fund projects. State Parks does the day to day, ODOT does the big stuff. Budgets are too small, and the level of service is being cut. Can do 1-2-day projects only.

Terra- We will work to help with funding, because we've been hearing about maintenance funding shortfalls for a while.

Ernie-It's a dilemma, we must reach out or postpone required work.

Approval of Minutes

Minutes approved.

Mile Marker Update

Connor & Dan

Green mile marker paddles are installed and have restored missing historic markers as well. Dan is in charge of The Dalles to Mosier. Used the smallest green paddle sign that is allowed. For the historic markers, 84 & 85 were missing, and they are now installed. It is completed.

Marc- What mile post should be used for 911? Use the green number.

Judy- Thankful for the installation, she lives on the highway.

Tricia- Likes the dark colored poles, asked about the back of the signs, what they look like? They are double mounted, and there is no back – the numbers are meant to be seen from either side (results in fewer signs).

Jannette- Happy to see the historic markers back. Where will the molds reside? It has been at the Dalles shop historically.

Mitchell Point Tunnel Updates

Austin Armstrong- Project Engineer (WFL) – Nearing the end of the project but still have work. There is light at the end of the tunnel. Most of the work has been inside the tunnel, West end of the tunnel and the parking lot itself. Placed concrete on the edges of the trail first to get a nice finish, then poured the center. There is 15 feet left at the end, but waiting for where the basalt bands will be placed.

West portal has been a focus for the last couple months. Form work is set up on the outside, placing the arch stones, set the keystone yesterday and there was an ODOT photographer on site – we'll have some good images.

MSE Wall- working on the excavation. Each basket is 18" deep and will be planted. Will install culverts to be able to install the safety guardrail.

The project is 77% complete, \$15.5M spent. Austin would like to get the trail paved by end of October; they are grading it on the east side now to prep. Looking at an early spring 2024 completion.

Richard Alfieri – What is the color inside the tunnel? The tunnel walls are lined with dark gray shotcrete, but the pavement is regular grey concrete.

David Duncan - Will there be concrete decking over the portals so when you come out of the portals there is protection? No, but there is rockfall protection.

Terra- Could we schedule a partner walk through sometime in October? Austin-If it doesn't interfere with the contactors (afternoon would be best)

Viewshed Management Review

Sandra Hikari (ODOT) & Jamen Lee (OPRD)

Sandra and Jamen provided an overview of the 2012 viewshed management plan, which aimed to restore views along the Historic Highway along a 13-mile section in the west end of the gorge. Restored filtered and panoramic views from the Historic Highway between Portland Women's Forum and Ainsworth State Park. The Historic Highway was designed to take advantage of the "beauty spots" in the Gorge, capturing the iconic views up and down the Gorge.

Did a very deep dive into what needs to be done, not just cutting down trees and removing vegetation. It was very methodical, and intentional. It was very muddy and snowy while the work was being done. It's simple maintenance once the initial start is done. Could be a work party going out with clippers year to year to maintain it. Some vegetation that was removed was invasive species, so it was habitat restoration as well.

Received an award from the work on the Viewshed management project. Lots of coordination with agency partners.

[AJ in chat] Is viewshed management and vegetation removal a part of the maintenance budget? Or a separate budget? Jamen - It was separate, but now it's follow up work on a much smaller financial scale.

[AJ in chat] Will the 3 existing trail portions be a viewshed audit done? Sandra - It's up to the committee to decide if that is something that needs to be done. Originally the views were found using postcards. So, looking at key view areas and seeing what could be done. It's no small feat, don't want to identify too many spots to keep the costs reasonable. Would be a good project but would need input from the Advisory Committee.

Ernie – I would like to raise the possibility of creating a viewshed dialog between OR and WA since they look at each other in the gorge.

David Duncan – There were some firs removed in the loops below Vista House on the Figure 8s – was that part of the viewshed management?

Jamen – unfortunately, those firs had died and were starting to deteriorate, so they needed to be removed prior to becoming a hazard.

Terra – Wayne Stewart (who is not in attendance today) has advocated in the past for viewshed opening along the State Trail – especially at places like Hole in the Wall falls, and other areas along the trail alignments.

Terra – Arthur Babitz (who is also not in attendance) would remind us that when the Historic Highway was built, there had been a fairly substantial fire in the Gorge, and so there were much fewer trees and shrubs when the Highway was constructed.

Judy – The historic picture of Rowena Loops has no trees, and we don't want to go back to that condition, so it's a balance.

Viento State Trail Park Opening Recap

Terra & Katelyn (ODOT)

In early September, ODOT opened 2 more miles east of Viento State Park. During the celebration, there were information booths including CAT, Safe Kids (booster seats and bike helmet fittings), Forest Service, Oregon State Parks had kid activities and Jr. Ranger program was there. Empanadas Maria Elba food truck was there, and the food was delish!

Lots of turn out from the cycling community, Portland Bicycle Club, Bike the Gorge, Sol Rides, E-bike Multnomah Falls, among others. Had lots of families and multigenerational groups. There was lots of enthusiasm for what's next, including the Mitchell Point Tunnel.

It was a really nice day, the winds were calm, and it was sunny and delightful. Cookies in the Parks office were delicious.

The State Trail is a magnet – people are attracted to the Trails and wanting to see the full alignment.

Richard – is there a gap between this segment and the Mitchell Point Tunnel?

Katelyn - There is a 0.7 mi gap between this new trail segment and the start of the Mitchell Point Tunnel Segment. We have funding identified, but it will not be allocated until 2026.

There was an old campground up there? Is that being restored?

Terra – yes, there was a Perham Creek campground. There is still a masonry plinth to indicate where it was, but we will not be restoring it as part of this project.

Marc - What's to keep folks from ignoring the trail closed sign?

Terra – There is a barrier at the end of the trail along with signs, and there are two bridges missing at Perham and Mitchell Creeks, so it's very hard to continue east without getting wet or using the shoulder of I-84.

Updates:

Next Meeting 12/7/23- This is revised. Looking at Troutdale but will confirm.

Friends of the Historic Highway:

Jannette- Historic Highway State Trail Consistency & Enhancement report- Contract with DEA is almost complete.

Lots of various activities this past summer and upcoming. Looking for new board members.

OPRD

David- Women's Forum, near a final concept. Got great feedback from the community. Will release the final concept to the public soon. Viento was a great opening. Hosted the open house inside the Parks facility. The Oregon State Park Commission and executive team came to the Mosier twin tunnels for an e-bike tour. Focused on past, present, and future of State Parks in the Gorge. Spoke on the next section and connectivity, and the scope of the State Trail and how fantastic it will be when complete.

Winding down on the busy season, however there is a picnic of 500 coming up. Twin Tunnel safety – in the process of ordering some more signage and striping at the beginning of the tunnels, where people need to slow down and be aware. Vista house- need to look at water infiltration issues in the building. Not sure if it is fixable. If they can solve the water infiltration issue, and do it within budget, it could be fixed.

Ernie – wondering about criminal activity at trailheads. David - seems to have decreased. Had better staffing this year compared to previous years. Have been working on graffiti removal as well throughout the Gorge. Underneath the viaduct at Vista house- You can see it from Rooster Rock- Need to figure out how to remove it – it's larger than regular staff can address.

USFS

Stephen Elgart – Not a lot of updates that can be shared. Looking at long term solutions for congestion and tourism, getting ideas from other agencies. Wrapping up/closing campgrounds on 10/1, volunteers will be clearing out. Bringing on a lot of staff, bringing on some winter seasonal workers, hopefully that will keep things safer during the winter. There has been an uptick on hiring, new positions created (been over 30 years since this has happened). Business Operations person to help with Human Resources/hiring. Landscape architect hired as well.

ODOT

Kent- More drastic budget cuts, lost 3 more employees. Can only do ½ as well for the Historic Highway segment. Lost 6 staff at Gov't Camp and 3 at Parkdale. Cascade Locks now has only 13 employees. The Historic Rail from Larch Mountain and Vista House, that's fixed, moving to Multnomah Falls rail area (this winter).

The green mile markers are being added on the Historic Highway today, and we're missing fewer historic concrete markers than we originally thought, but working on restoring those now.

Terra- Kristen Stallman is retired, and now working at Western Federal Lands administrating FLAP grants on the Washinton side. Retirement party is tomorrow. Still looking for a Multnomah County Governor's representative, Ernie is willing to stay on for now until we have gotten more of a quorum of applications (apply in Workday). Yesterday WSP and WFL accepted an award on the Mitchell Point Tunnel. Will share the plaque and award with all later.

We're drafting a grant application for construction funding from Mitchell Point Tunnel to Ruthton Point trail head, have more state match to apply for the grant from the Nationally Significant Federal and Tribal Lands Program. Will be at 50% design by end of the year.

Multnomah Falls Viaducts project went out to bid last week, start of construction and traffic impacts in fall 2024.

Summer Pilot Recap

Terra (ODOT)- Multnomah Falls Timed Use Permits from this summer.

3rd year, in continuing collaboration with agency partners.

New Multnomah Falls Parking configuration was implemented this year.

Goals: Improved safety at Exit 31, reduce congestion and back ups on the Historic Highway.

This summer, there were 120-80 permits available per hour between 9am-6PM, down 40 tickets a day from last year. There were 50 in-person permits per day split between Troutdale and Cascade Locks. Over 77,000 permits reserved online. Friday-Monday continue to be high demand days, 10am-3pm are still peak hours.

We tracked CAT ridership, June and July exceeded 2022, but August saw fewer riders than 2022.

More traffic volume this year on the Historic Highway probably because of the lack of time use permits on the waterfall corridor.

Looked at pedestrian volumes, this year saw more pedestrians than 2022, still down from 2017.

Cyclists- Less cyclists this year but loads of E-Bikes. For bike parking, need to look at ways to maintain the pedestrian throughways in the Multnomah Falls plaza, and the Forest Service considers e-bikes motorized vehicles, so we need to determine how to better accommodate visitors arriving by bicycle. [AJ in chat]: One vehicle parking spot can accommodate 8 cycles.

Sasquatch Shuttle is operating the lot, and this year they reconfigured the parking lot to enter on the west side and exit near the crosswalk. They had people turn around at the shuttle turn around when the lot was full.

The parking lot attendant took a car count this summer to see the average in the historic highway lot by hour. Roughly 250 cars daily.

For Summer 2024: Likely continue to fund a flagger, Sasquatch will operate the highway lot.

David – Wanted to extend thank you for Sasquatch operating the lot and noticed that traffic really flowed smoothly through the Multnomah Falls area on the Historic Highway.

Were there any congestion issues with the reconfiguration for shuttles or users? Not at Multnomah Falls, but this is the first year that they've seen congestion at Wahkeena as folks parked there and walked to the Falls.

US 30 Curve Warning Signs

Jermy Seitz (Region Sign engineer)- The curve warning project extends from Troutdale to Hood River on the Historic Highway. But most signing stops at the Ainsworth interchange. Using technology and best practices to determine the appropriate speeds around curves, and the project will add yellow diamond speed warning signs around the curves. There are lots of long winding sections, so they focused signage where needed. Usually, signage is considered a maintenance activity, but this time had to program it as a project due to the length. The scope is still in flux due to budget, but about the same number of signs.

13th and Oak- adding the reflective border around the traffic signal.

Need better signage at the on/off ramp after Toothrock tunnel, especially asking cyclists to cross the off ramp heading to the stairs, where people really are not really slowing down.

Committee Roundtable

Judy: Rode the Olympic discovery trail. Glad that we went from 3 to 5 adits so there is light in the tunnel.

Tricia: On the Mitchell Point tunnel and lights, wondering if there is away to add a reflective surface to where people could see where walls pop out. Terra said that we cannot have reflective surfaces in the gorge.

Terra: Stay tuned for a Mitchell Point Tunnel tour in October.

Adjournment

Ernie adjourned the meeting at 1:28 PM.

STATE TRAIL CONSISTENCY AND ENHANCEMENT REPORT 2023

A COMPANION PIECE TO THE STATE TRAIL GUIDELINES OF 2011



MAY 2023

WORKSHOP ATTENDEES

SPONSORED BY:

**THE FRIENDS OF THE
HISTORIC COLUMBIA
RIVER HIGHWAY**

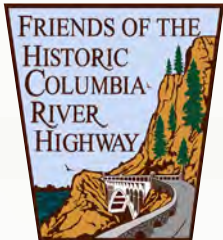

Magnus Bernhardt, Oregon Department of Transportation

Robert Hadlow, Oregon Department of Transportation

Kent Kalsch, Oregon Department of Transportation

Terra Lingley, Oregon Department of Transportation

Diana Powers, Oregon Department of Transportation

Kristen Stallman, Oregon Department of Transportation

Jenna Marmon, Oregon Parks and Recreation Department

David Spangler, Oregon Parks and Recreation Department

Stephen Elgart, US Forest Service

Casey Gatz, US Forest Service

Kevin Bracy, David Evans and Associates, Inc.

Bailey Flint, David Evans and Associates, Inc.

James Hencke, David Evans and Associates, Inc.

Mike Zilis, WalkerMacy

Wayne Stewart, Historic Columbia River Highway Advisory Committee

Jeanette Kloos, Friends of the Historic Columbia River Highway

AJ Zelada, Friends of the Historic Columbia River Highway

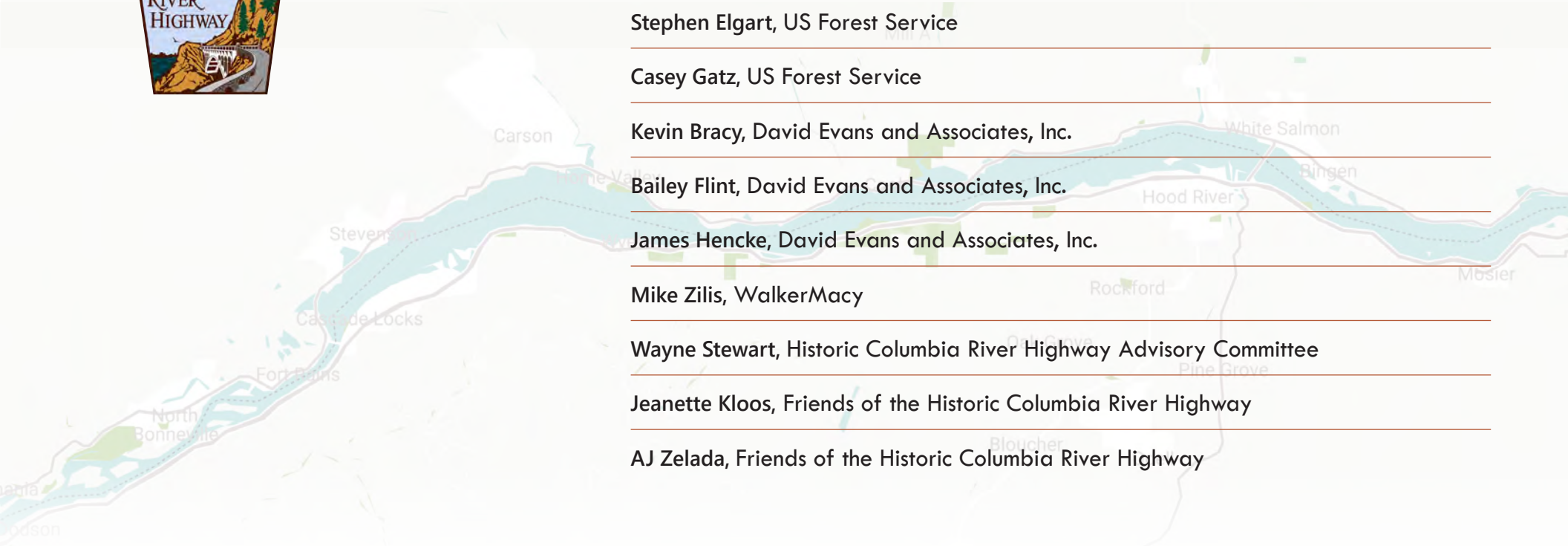

CONTENTS

Introduction	1
Transitions	4
Bollards	6
Wood Railings	7
Fences	8
Gates	10
Seating	11
Bike Racks	13
Picnic Tables	14
Trash and Recycle Containers	15
Signage	16
Curbs and Edges	19
Consistency Opportunities	20
Appendix	22

INTRODUCTION

CHALLENGE

To future designers, builders, and maintainers of the Historic Columbia River Highway State Trail: May you be inspired by the beauty of the original design and its legacy and be challenged to create and maintain a comparable work of art for the enjoyment of future generations.

HISTORY

The Historic Columbia River Highway (Historic Highway) was the first scenic highway in America. The design of the road solved major engineering challenges and was an aesthetic triumph of its time. One of the most important consequences was its influence on the National Park Service's scenic parkways which were being developed across the country during the same period. Additionally, the Historic Highway is noted for its attention to design details resulting in an iconic style and construction techniques for rustic guard walls, guard stones, bridges, and retaining walls. The overall design of the Historic



EXHIBIT 1: *Sam Hill.*

EXHIBIT 2: *Possibly John B. Yeon, Sam Hill, J. C. Porter, and Amos S. Benson (left to right).*

Highway was as important as was the sound engineering and sensitivity to the landscape. This includes the alignment of the road and its relationship to the geology and geomorphology of the Columbia River Gorge. The Historic Highway was laid out to be interesting to drive with graceful curves and changes of grade. It unrolled before the driver as a dynamic sequence of views, vistas, and scenic "events" such as waysides, fountains, and waterfalls.

GOING FORWARD

In 1987 the Oregon Legislature directed the Oregon Department of Transportation (ODOT) to develop a program leading to reconnection of missing sections of the Historic Highway with a State Recreation Trail.

To the extent practical, the State Trail alignment includes isolated remnants of the Historic Highway and integrates them into a continuous recreation route between Troutdale and The Dalles.

This Consistency and Enhancements Report is intended to be a companion piece with the 2011 State Trail Guidelines, which continue to guide development of the State Trail. Over time, the goal is to enhance consistency and ensure that the State Trail measures up to the vision of Samuel Lancaster and other early designers.

To ensure continuity and consistency, the design and maintenance of the State Trail and associated elements calls for attention to detail and preservation of the high quality of art emblematic of the original highway.

The State Trail has been designed and constructed over the past 30 years in short sections as funding has been secured.

The trail consists of three segments: Bonneville, Mitchell Point, and Twin Tunnels. Numerous individuals and organizations have been instrumental in moving the Trail towards completion. Now, as construction of the final two plus miles of Trail is in sight, it is time to review the visual appearance of Trail elements with an eye toward ensuring consistency along the 22 total miles of Trail among the three segments. Some of the Trail elements used early in the reconnection work have stood the test of time and continue to set the standard for future work.



EXHIBIT 3: *East Portal, Mitchell Point Tunnel.*

Other elements have been improved upon in later construction contracts and should supersede earlier designs. A few currently recommended elements were not included in the earlier work and should be added as funding allows.

Historically, the grade of the Historic Highway was held to 5% to accommodate the climbing ability of vehicles in the early 1900's. Wherever possible, this grade is maintained along all Trail segments and matches the 1990 Americans with Disabilities Act standards.



EXHIBIT 4: *East of Viento Trailhead.*

Each of the trailheads were designed at different points in time to respond to specific site opportunities and constraints.

In general, most trailheads contain the following elements: parking, orientation plaza, signage, bike racks, trash containers, and a trail entry.

Other desired features, which are not available at all trailheads, include: bathrooms, potable water, picnic tables, bike repair stations, interpretive signage, and seating.

The purpose of this Consistency and Enhancement Report is to identify the most appropriate elements for continued use along the State Trail whenever additions, repairs or replacements are warranted and funding is available. Additional enhancements may be warranted at selected trailheads as visitor use patterns evolve over time. The Oregon Parks and Recreation Department (OPRD) staff is encouraged to periodically review visitor use patterns and lead enhancement studies as appropriate.

Friends of the Historic Columbia River Highway (FHCRH) worked with staff members of the ODOT, OPRD, and the United States Forest Service (USFS) to develop the following recommendations.



EXHIBIT 5: *Steel road construction wagons designed by Samuel Lancaster. Photo: Maryhill Museum of Art.*

TRANSITIONS

RECOMMENDED DESIGN ELEMENTS

- **Concrete pylons placed on both sides of the Trail at vehicle crossing locations**
- **Hinged wood bollard centered between pylons**
 - **Maintain a seven foot maximum spacing between pylon face and bollard centerline**
- **Up to three basalt bands approaching the transition plus one band between the pylons**
- **Tactile warning strips meeting ADA requirements at the junction of the Trail and vehicle route**

Transitions occur at locations where the State Trail either crosses or merges with a vehicle road or parking area. Visual elements are included in the transition area design to warn trail users that they need to slow down and increase awareness of the potential for encountering motor vehicles. The transition design also prevents vehicles from inadvertently accessing the Trail. Finally, precast concrete pylons at each side of the trail act as entrance markers and help to create a “brand” for the Trail.

To promote consistency, wherever practical, the following elements should be included

at each transition location: precast concrete pylons located on each side of the Trail, a hinged bollard in the center of the Trail, a tactile warning strip that meets ADA requirements at the junction of the Trail and a vehicle area, and basalt “rumble strips” spaced about 20 feet apart to warn cyclists to slow down. It is recognized that site conditions at transition locations vary and that designs will need to be customized for each location. Exhibit 6 illustrates the recommended design for a typical transition location.



EXHIBIT 6: *Recommended transition design. Existing transition at Viento Trailhead.*

HCRH STATE TRAIL CONSISTS OF THREE SEGMENTS

Bonneville Segment spans from Western entrance at J B Yeon State Park to the Eastern entrance at Cascade Locks.

Mitchell Point Segment from Western entrance at Wyeth State Park to the Eastern entrance at Ruthton Trailhead.

Twin Tunnels Segment from Western entrance at Hatfield West Trailhead to the Eastern entrance at Hatfield Eastern Trailhead.

LOCATIONS OF TRANSITIONS ALONG THE STATE TRAIL

ID	STATE TRAIL SEGMENT	EXIT(S) ALONG INTERSTATE I-84
A	J.B. Yeon State Park	35 Eastbound; 37 Westbound
B	Bonneville Way	40 Eastbound; 40 Westbound
C	Eagle Creek Fish Hatchery	41 Eastbound Only
D	Cascade Locks	44 Eastbound; 44 Westbound
E	Wyeth Trailhead	51 Eastbound; 51 Westbound
F	Starvation Creek Trailhead	55 Eastbound Only
G	Viento Trailhead	56 Eastbound; 56 Westbound
H	Mitchell Point Trailhead	58 Eastbound Only
I	Ruthton Trailhead	62 Eastbound; 62 Westbound
J	Senator Mark O. Hatfield West Trailhead	64 Eastbound; 64 Westbound
K	Senator Mark O. Hatfield East Trailhead	69 Eastbound; 69 Westbound

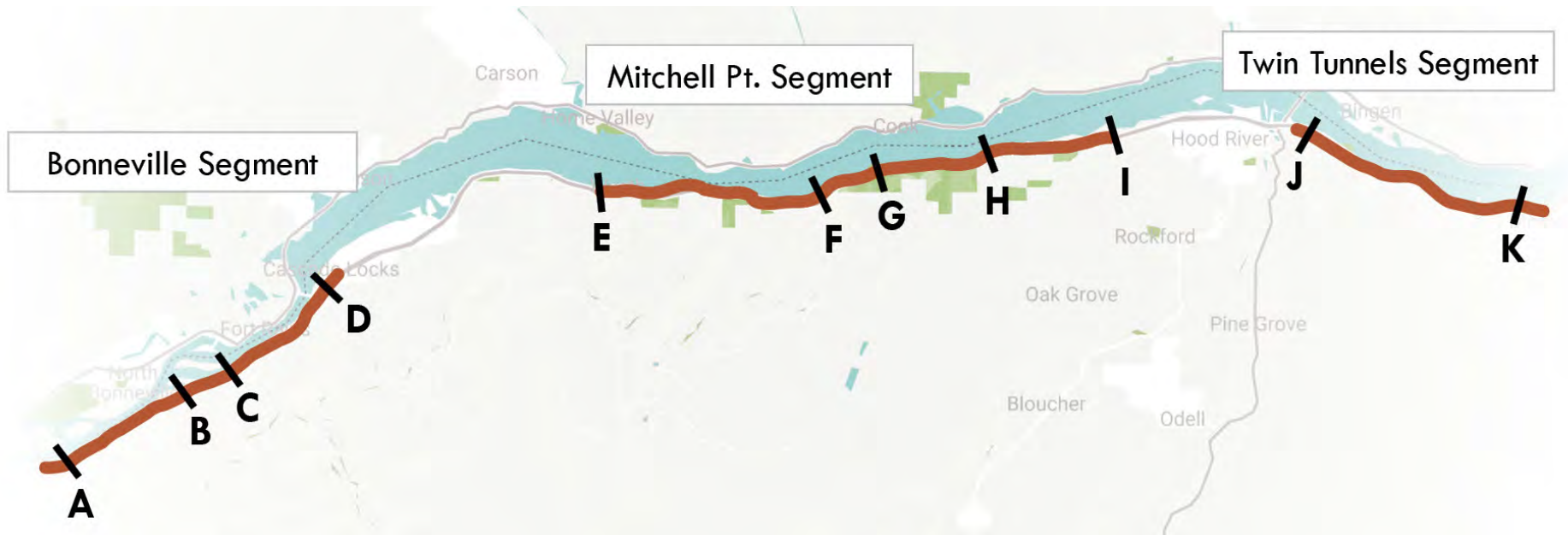

EXHIBIT 7: *The State Trail Segments.*

BOLLARDS

RECOMMENDED DESIGN ELEMENTS

- Chamfered top
- Rabbeted groove with reflective tape
- Hinged base with metal kerf plate
 - Hinge should prevent bollard movement when locked in place
 - Maximum 6.5 inch obstruction height when in down position
- White painted, non-incised pressure treated wood

Bollards are used to control vehicle access to the State Trail. A hinged wood bollard with a locking plate is preferred as it provides easy access for maintenance and emergency service personnel. When in the lowered position the height above the pavement needs to be a maximum of

6.5 inches to ensure that police vehicles can drive over the obstruction. This design also minimizes opportunities for vandalism and damage. Recommended design elements for bollards are listed to the left. See drawings in the Appendix for further guidance.



EXHIBIT 8: *Recommended bollard design. Existing bollard at Viento Trailhead.*

WOOD RAILINGS

RECOMMENDED DESIGN ELEMENTS

- **Two-rail design**
- **Dark brown in color unless otherwise identified as being historically white at the given location**
- **3-inch by 8-inch rails (rough cut measure)**
- **6x8 posts (nominal measure)**
- **Fastenings to be countersunk**

Wood railings throughout the State Trail system are either white or brown depending on whether the railings were part of the original highway or were added later. The only railings that should be white are those that are identified in the 1924 Engineers Log Book that is archived by ODOT. See drawings in the Appendix for further guidance.

The two-rail design has become an iconic feature of the State Trail. However, in this steep wooded setting, rockfall and falling trees annually take a toll on posts and rails. Over the years, a number of dimensional variations have crept in and maintenance staffs must either stockpile multiple sized rails or place custom orders each time a repair is needed. The staff of ODOT and OPRD have asked that a single standard for rails be developed.

To adhere to the 1920s-1930s rustic appearance the use of heavy wood members seems most appropriate for the two-rail wood railings. Therefore, going forward, the standard for rails will be 3 inches by 8 inches (rough cut measure). It is understood that when doing repairs the new standard will not always blend smoothly with existing conditions.



EXHIBIT 9: Recommended white wood railing design. Existing white wood railing at Mitchell Point Trailhead.



EXHIBIT 10: Recommended brown wood railing design. Existing brown wood railing at Viento Trailhead.

FENCES

ACCESS CONTROL FENCING RECOMMENDED DESIGN ELEMENTS

- **Twin Tunnels Segment**
 - Round mortised posts and rails
 - Black vinyl chain link mesh backing
- **Bonneville and Mitchell Point Segments**
 - 3-inch by 8-inch rails (rough cut measure)
 - 6x8 pressure treated posts (nominal measure)
 - Fastenings to be countersunk
 - Dark brown or black wire mesh backing (4-inch square grid)
- **Dark brown wood color**

In some locations control of access to dangerous or sensitive cultural areas is important. In the Twin Tunnels section of the State Trail both round mortised posts and rails (with black vinyl chain link mesh) and steel posts (with v-mesh wire backing) have been used.

When repair of this fencing is required, continue using the same design and materials.

If new fencing is needed along the Bonneville or Mitchell Point sections of the Trail, the fencing should be the two-rail design discussed earlier backed by dark brown or black 4-inch square wire mesh. Using the two-rail design will limit the need to stockpile various dimension wood members and will blend with the extensive use of this design throughout the Bonneville and Mitchell Point sections. See drawings in the Appendix for further guidance.



EXHIBIT 11: Existing access control fence in the Twin Tunnels section.

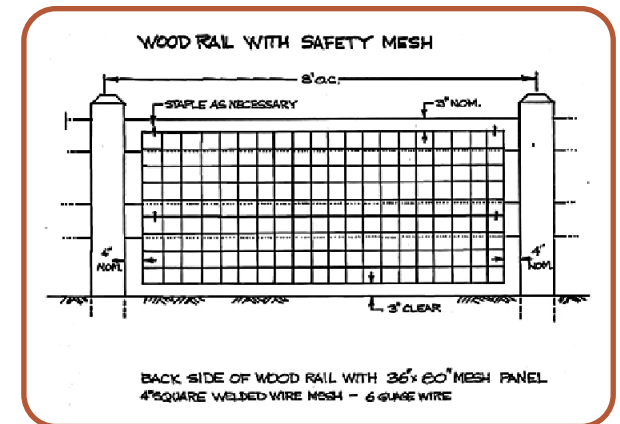

EXHIBIT 12: Brown two-rail wood fence with wire mesh backing.

I-84 PROXIMITY FENCING
RECOMMENDED
DESIGN ELEMENTS

- 4-wire fencing >50 feet from the Trail
- 6-wire fencing <50 feet from the Trail
- Posts and wires to be dark brown or treated with a weathering agent

There are two types of proximity fencing along I-84 — non-climbable ‘V’ mesh and 4-wire. The ‘V’ mesh works well to keep small children and dogs from venturing onto the shoulder of the freeway. However, this type of fencing does not stand up to snow removal operations and is frequently knocked down. The 4-wire fence stands up much better to snow removal operations, but is not much of a deterrent for children and dogs.

There are a number of locations where the Trail comes within 50 feet of the I-84 shoulder. In these locations, added protection should be provided. Adding two additional wires and adjusting the spacing between wires should be adequate to provide a reasonable degree of protection for children and dogs. Exhibit 15 illustrates the recommended spacing of wires for proximity fencing near the State Trail.



EXHIBIT 13: Existing V-Mesh fencing between Wyeth Trailhead and the Summit Creek Viaduct.



EXHIBIT 14: 4-wire fencing near Viento.

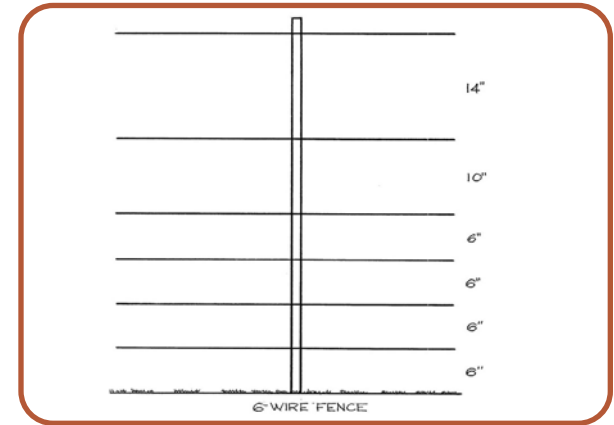

EXHIBIT 15: 6-wire fencing design.

GATES

RECOMMENDED DESIGN ELEMENTS

- **Paint all gates dark brown or treat with weathering agent**
- **Metal Swing Gate**
 - Standard ODOT Design Gate
 - Child safety protection
- **Simple Closure Gate**
 - Steel frame with diagonal support
- **Specialty Gates**
 - Arched member
 - Stone masonry columns with a battered design

There are three types of gates used along the State Trail. The first type is a metal swing gate used to provide emergency and service access from I-84 to the Trail. The gates use a standard ODOT design that includes diagonal wire bracing. This design provides no protection for children and pets, but can be easily modified. The addition of horizontal wires six inches on center will provide a reasonable level of protection.

The second type of gate is used to close off access to vehicles and can also be used to close off sections of the State Trail during emergencies such as in the event of rockfall or downed trees.

Recommended design elements for simple closure gates are listed to the left. See drawings in the Appendix for further guidance.

The third type are specialty gates, such as those that are located at both the Hatfield West and East trailheads. In the future, if additional specialty gates are needed, the design should be similar to the design of the Hatfield West gate. Recommended design elements for specialty gates are listed to the left.



EXHIBIT 16: *Recommended swing gate design. Existing swing gate west of Starvation Creek.*



EXHIBIT 17: *Recommended simple closure gate design. Existing simple closure gate at Viento Trailhead.*



EXHIBIT 18: *Recommended specialty gate design. Existing specialty gate at Hatfield West Trailhead.*

SEATING

RECOMMENDED DESIGN ELEMENTS

- **Columnar basalt seating where needed adjacent to the trail**
- **Manufactured bench seating in trailheads**
 - Finish metal portions in dark brown or black or treat with a weathering agent
 - Backs and arm rests
- **Stone masonry seat walls**
 - Source basalt stone from Corbett Quarry



EXHIBIT 19: Recommended design for columnar basalt seating. Existing seating east of J B Yeon State Park.

There are three types of seating found along the State Trail: columnar basalt seating, manufactured benches, and basalt stone masonry seat walls.

Columnar basalt is used in both horizontal bench and vertical seat positions. Columnar basalt is the preferred material as it is both from the geologic area and virtually maintenance free.



EXHIBIT 20: Recommended design for columnar basalt seating. Existing columnar basalt seating at a variety of locations.

Manufactured bench seating is most appropriate at trailheads and at locations where recreationists tend to gather.

Basalt stone masonry seat walls are located at several of the trailheads. Seat walls should match the details of those at Viento and Wyeth Trailheads. Recommended design elements for seating are listed to the left. See drawings in the Appendix for further guidance.

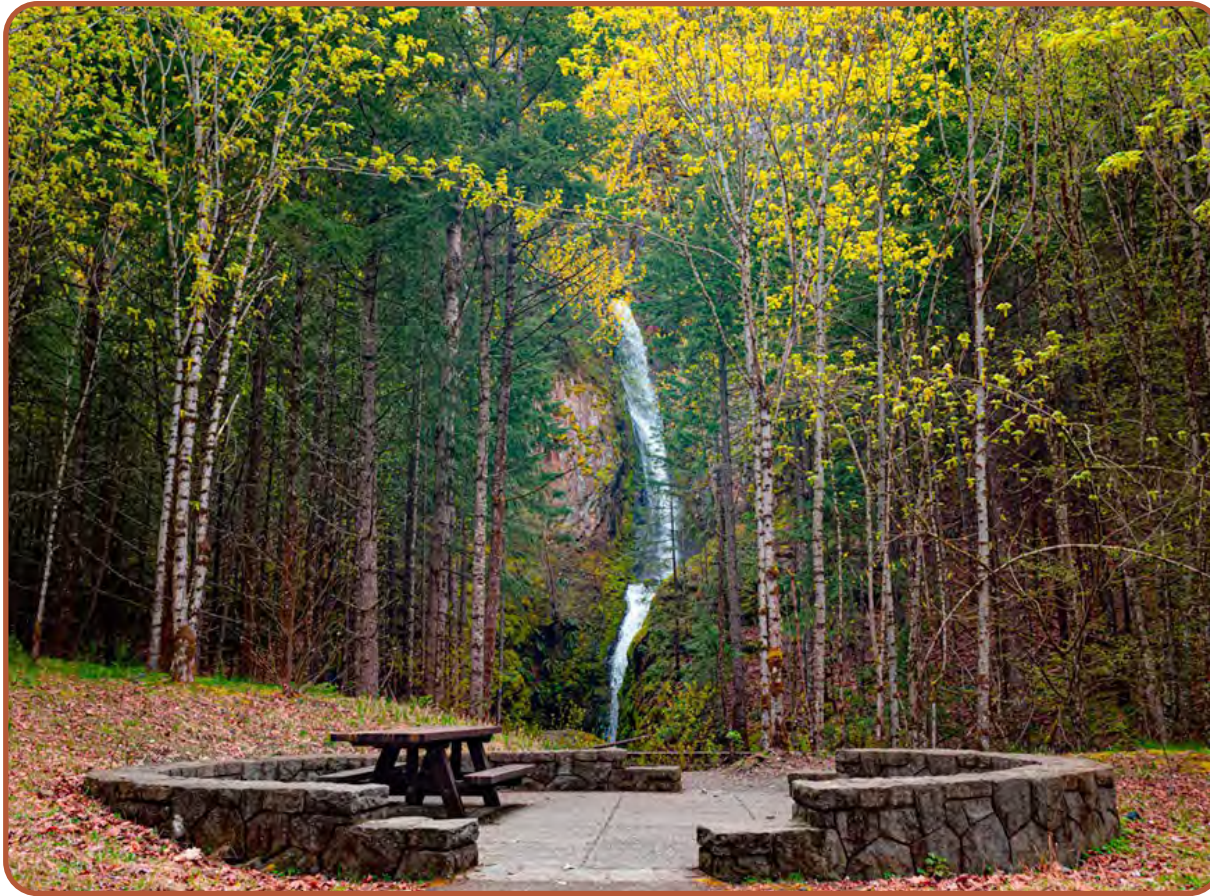

EXHIBIT 21: *Recommended design for seat wall. Existing seat wall at Hole in the Wall Falls.*



EXHIBIT 22: *Historic stone seating at Eagle Creek Overlook.*

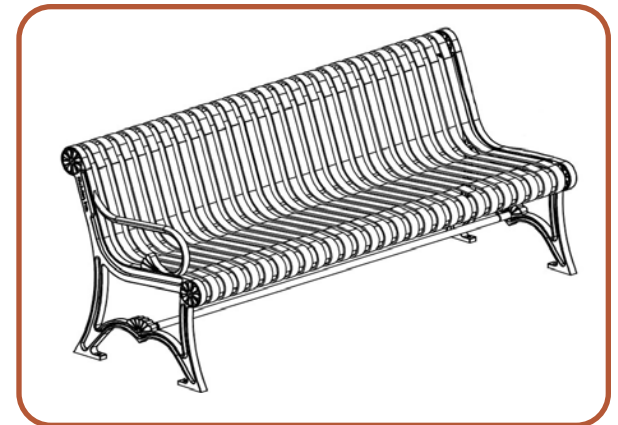

EXHIBIT 23: *Recommended design for manufactured bench seating.*

BIKE RACKS

RECOMMENDED DESIGN ELEMENTS

- **Horizontal top bar with rounded corners**
- **Must be dark brown/black color or treated with a weathering agent**
- **Space bike racks 48 inches apart to maximize capacity**

Most of the bike racks located along the State Trail are variations on a staple like design, with a horizontal top bar being the preferred design. This simple design is recommended for its functionality, reduced ability to be vandalized and lack of visual prominence. Recommended design elements for bike racks are listed to the left. See drawings in the Appendix for further guidance.

Consideration should be given to spacing between staple racks. This is important for long distant cyclists with panniers to unload. In addition, electric bikes and cargo cycles are larger space occupying cycles which often carry children seats.



EXHIBIT 24: Recommended bike rack design. Existing bike rack design at Viento Trailhead. At the right is a bicycle tool fix-it station.

PICNIC TABLES

RECOMMENDED DESIGN ELEMENTS

ADA compliant Tables and Seating Permanent Placement

- Concrete construction
- Dark brown or dark grey color
- Smooth top and seats

Movable Tables

- Metal frame
- Metal parts must be dark brown/black color or treated with a weathering agent
- Wood top and seats

Two types of picnic table are proposed for use along the State Trail – a concrete version for use where longevity and permanence are important and a metal base/wood top version for use where movement flexibility is important. Picnic tables are generally limited to trail heads and should be of concrete. Metal base/wood tops tables may be used in temporary locations and to test the need for permanent tables.

All tables should have a top extension at one end to accommodate wheelchairs. The permanent tables should be anchored to a concrete or asphalt pad. The pad must meet the ADA guidelines and to be sufficiently large to accommodate wheelchair access and maneuvering. See drawings in the Appendix for further guidance.



EXHIBIT 25: Recommended ADA picnic table design. Existing picnic table at Viento Campground.

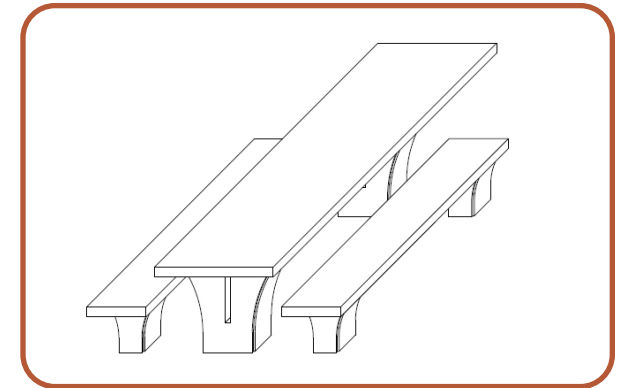

EXHIBIT 26: Recommended concrete table design for ADA picnic table.

TRASH AND RECYCLE CONTAINERS

RECOMMENDED DESIGN ELEMENTS

- Oregon Parks and Recreation Department preferred metal frame with a removable plastic container
- Lockable cage and metal top
- Metal parts must be dark brown/black color or treated with a weathering agent

Throughout the State Trail system there are no adopted standards for trash and recycle containers. All trash containers are located at trailheads, but additional containers may be desired along the Trail in the future. The most common design at many trailheads features a plastic trash container placed within a wood frame.

As the current design is inconsistent with Historic Highway standards, a new system for accommodating trash and recycle containers is recommended.



EXHIBIT 27: Recommended locking metal frame trash container.

SIGNAGE

Signage at trailheads has been extensively studied and will not be discussed further in this report. Signage along the State Trail should remain limited to the following:

- **Connections to USFS Gorge trails**
- **Historic highway concrete mile markers**
- **Medallions at historic alignment/new trail interfaces**
- **Location markers for emergency use**
- **Trail control and warning signs (e.g., speed, curves, congestion warning)**

CONNECTIONS TO USFS TRAILS

There are several locations where the USFS trails take off from or cross the State Trail. Signage at each of these locations should provide common information and use the same physical elements to identify the name and number of the trail. Signage is required to conform to Columbia River Gorge National Scenic Area sign standards.



EXHIBIT 28: *Recommended Gorge trail connection signage designs.*

HISTORIC HIGHWAY CONCRETE MILEAGE MARKERS

Triangular concrete mile markers were installed along the length of the Historic Highway alignment. Over the years many of the original mile markers were lost due to construction, accidents, or theft. Currently, only one original marker remains in place along the State Trail at Mile 58 (between Starvation Creek and Viento).

A replacement concrete marker is located at Mile 63 (near Ruthton Point).

To the extent feasible, existing stretches of the original highway have been integrated into the State Trail. Wherever mile markers would have occurred on these stretches of original highway, replacement concrete mile markers should be manufactured and installed.

Concrete mile markers should be replaced at the locations indicated in the 1924 Engineers Log Book, if the original alignment is part of the State trail.

MEDALLIONS

After several sections of State Trail were constructed, ODOT wanted to indicate what portions were on the original alignment of the Historic Highway and which portions were new trail. This began with the new construction in 2013, with the older sections of trail receiving medallions a couple of years later. Now, all new construction projects include medallions when constructed.

At the interface between the original highway alignment and the new State Trail alignment, medallions are inserted into the pavement overlay. The Consistency Opportunities page details medallions that have been placed incorrectly and should be removed and replaced.



EXHIBIT 29: Existing Mile 58 mileage marker.



EXHIBIT 30: Medallions are typically placed in pairs, on opposite sides of the Trail, with one medallion (left) pointing toward the original road alignment and the other (right) pointing toward the new Trail alignment.

Above: Both medallions are on the Summit Creek Viaduct, constructed in 2018.

TRAIL CONTROL AND WARNING SIGNS

RECOMMENDED DESIGN ELEMENTS

- Simple wood post
- Follow Manual on Uniform Traffic Control Devices guidance
- Smallest size practical
- Finish backs of signs in a dark brown color

EMERGENCY MARKER RECOMMENDED DESIGN ELEMENTS

- Thermoplastic marker placed on Trail center line
- Place marker either 1.0 mile or 0.5 mile apart
- White border, black background, white numbers
- 10 to 12 inches in diameter

TRAIL CONTROL AND WARNING SIGNS

There are a limited number of signs in place to alert State Trail users to hazards such as sharp curves or a stop ahead. While there are no speed signs in place now, as recreation use increases there will be a need to control bike speeds in congested areas and to warn users of potentially dangerous situations.

LOCATION MARKERS FOR EMERGENCY USE

Place location mile point markers along the State Trail to assist emergency responders in locating persons needing assistance.

To eliminate confusion with the ODOT mile numbering system for I-84 and the drivable portion of the Historic highway, it is recommended that the State Trail emergency mile point markers be of a totally different appearance than the 'green paddle' markers used by ODOT.

Thermoplastic markers are proposed to be placed on the centerline of the Trail, with numbers that can be read from both directions.

- Bonneville Section Numbers 1-19
- Mitchell Point Section Numbers 20-39
- Twin Tunnels Section Numbers 40-59

The beginning number should be at the west end of the section with numbers increasing toward the east. As desired, markers can be placed one mile apart or one-half mile apart.



EXHIBIT 31: *Proposed thermoplastic emergency marker.*

CURBS AND EDGES

RECOMMENDED DESIGN ELEMENTS

- Basalt stone from Corbett Quarry
- Roughly rectangular shaped stones with uniform thickness
- One-half inch mortar joints
- Less than one-quarter inch tolerance in joints



EXHIBIT 32: Recommended stone curb design. Existing stone curb at Viento Trailhead.

Where curb or edge definition is needed, basalt stone is preferred and should be installed wherever practical. Cast-in-place concrete curbs should be limited to utility locations and locations away from the State

Trail. Recommended design elements for curbs and edges are listed to the left. See drawings in the Appendix for further guidance.



EXHIBIT 33: Recommended stone edge design. Existing stone edge at Viento Trailhead.

CONSISTENCY OPPORTUNITIES

J. B. YEON STATE PARK TRAILHEAD

- Replace existing “lift out” bollards with hinged bollards
- Add bike racks
- Add a bike fix-it station
- Add tactile warning strips
- Add two trash containers (State Trail entrance, Elowah Falls trail)
- Move ADA parking adjacent to the State Trail entrance
- Restripe parking stalls

BONNEVILLE WAY TRAIL CROSSING

- Widen east side Trail to standard 14-16 foot width
- Reconfigure the east side Trail entrance
- Add concrete pylons on each side of Bonneville Way
- Add hinged bollards
- Add tactile warning strips on each side of Bonneville Way
- Add basalt stone bands as appropriate
- Add thermoplastic pedestrian crossing (from west side to the existing stone seat wall, and from the seat wall to the east side)

TOOTHROCK TRAILHEAD

- Add bike racks
- Add trash container(s)
- Add a bike fix-it station
- Add vault toilet
- Add a picnic table

CASCADE LOCKS TRAILHEAD

- Replace existing bollard with a hinged bollard
- Add a basalt stone band at the bollard location
- Add bike racks
- Add a bike fix-it station
- Add a trash container
- Add a picnic table at the overlook area
- Add a bench at the overlook area facing downriver
- Repair stone curbing
- Restripe parking stalls

WYETH TRAILHEAD

- Add a trash container
- Add a bench near the ADA parking stalls
- Add a picnic table near the ADA parking stalls
- Add pylons at the start of the asphalt trail
- Remove the yellow diamond at the trail bollard

WYETH CAMPGROUND ACCESS ROAD (TRAIL CROSSING)

- Add basalt stone band under bollard at the bridge
- Remove the yellow diamond at the eastern bollard

STARVATION CREEK STATE PARK

- Add tactile warning strip (approximately 22 feet long)
- Add trash container(s)
- Replace picnic table near historic highway sign
- Add a bench at the trail orientation plaza
- Replace the existing bollards with white hinged bollards (3)

VIENTO STATE PARK TRAILHEAD

- Add trash containers (one at the restroom, one at the trailhead)

MITCHELL POINT TRAILHEAD

- Add trash container(s)
- Add a bench

CONSISTENCY OPPORTUNITIES (CONTINUED)

HATFIELD WEST TRAILHEAD

- Add trash containers
- Add a bike fix-it station
- Add a bench (north side of building)
- Replace the picnic table near the bathrooms
- Install directional sign at the Trail/Historic Highway split near the trailhead

HATFIELD EAST TRAILHEAD PARKING AREA

- Add a trash container
- Add bike racks

MEDALLIONS

- Relocate both Medallions to correct location and orientation West of Moffett Creek Bridge
- Add Medallions at the Power Line Original Alignment
- Relocate both Medallions to correct location and orientation West of Tanner Creek Bridge
- Relocate both Medallions to correct location and orientation East of Action Substation

- Reorient the existing Medallion to the correct direction at Eagle Creek and add a Medallion to include the Eagle Creek Bridge to the white guardrail
- Reorient the existing Medallion to the correct direction and add a Medallion West of Ruckel Creek Bridge
- Add two pairs of Medallions at the Trail detour south of I-84
- Add a pair of Medallions at the Trail departure from on-ramp
- Relocate both Medallions to the correct location and orientation at the Cascade Locks Trailhead
- Replace with new Medallion at the base of ramp to Starvation Creek
- Relocate both Medallions to correct location and orientation past pump house toward waterfall
- Remove Medallion located in the Mosier Twin Tunnels

APPENDIX

BASALT BAND

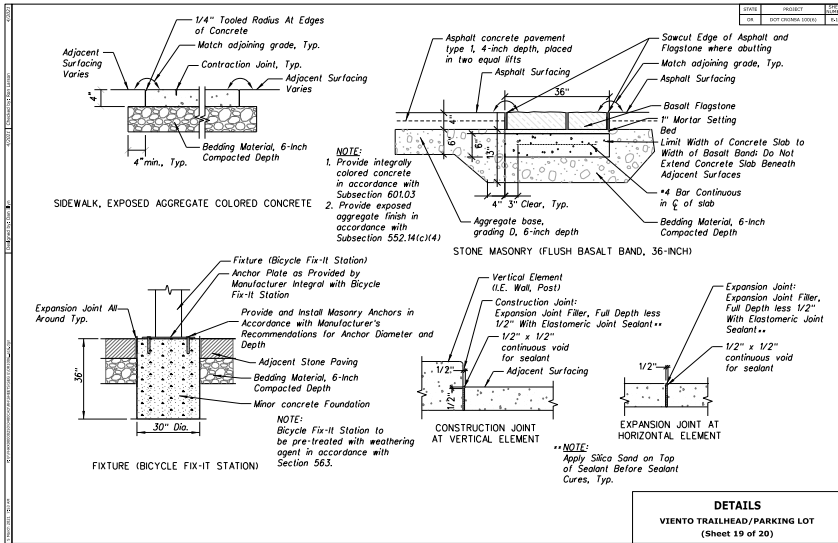

THRESHOLD DETAIL

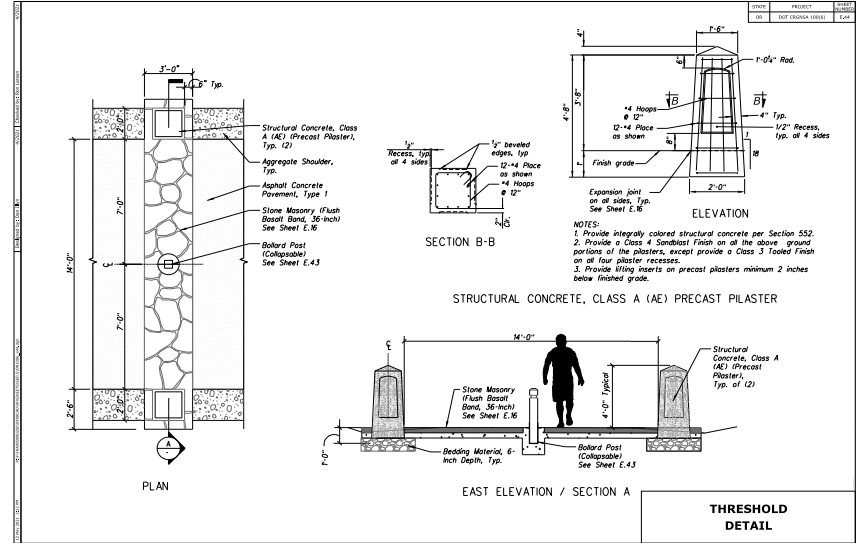

HINGED BOLLARD

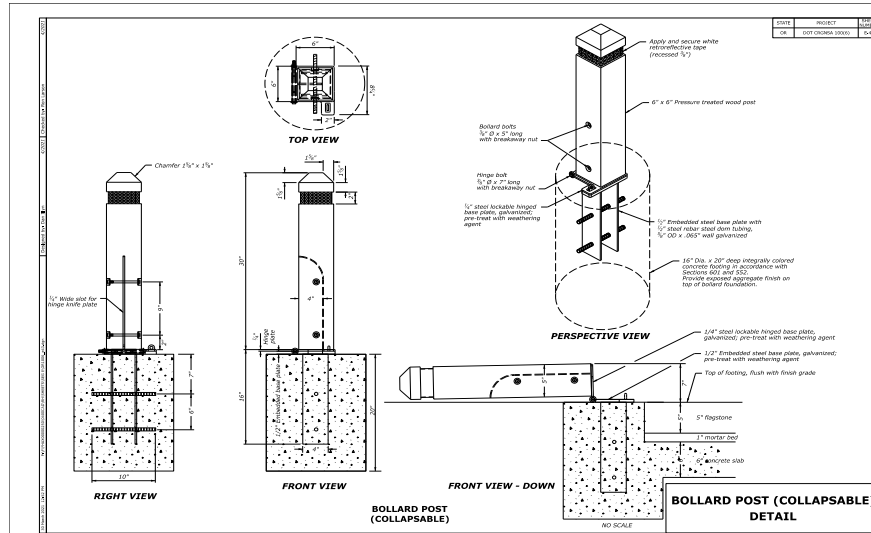

WOOD RAILING

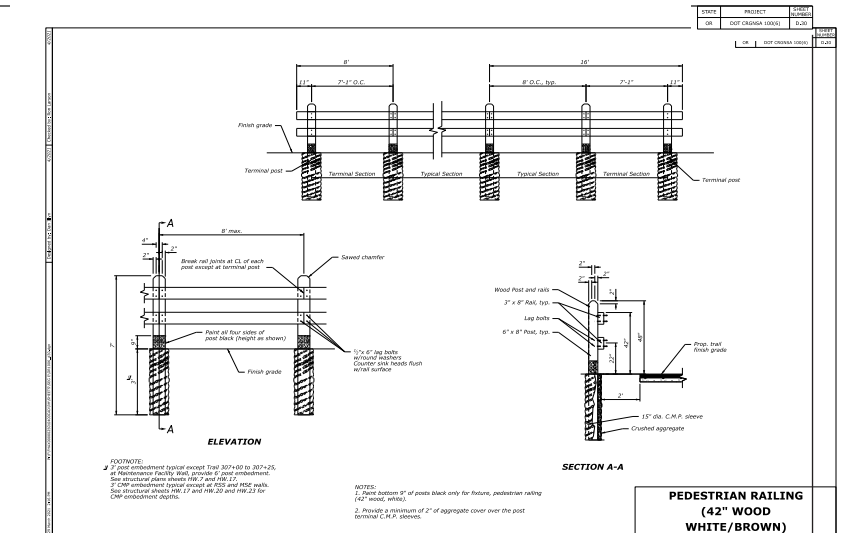

APPENDIX

SIMPLE CLOSURE GATE

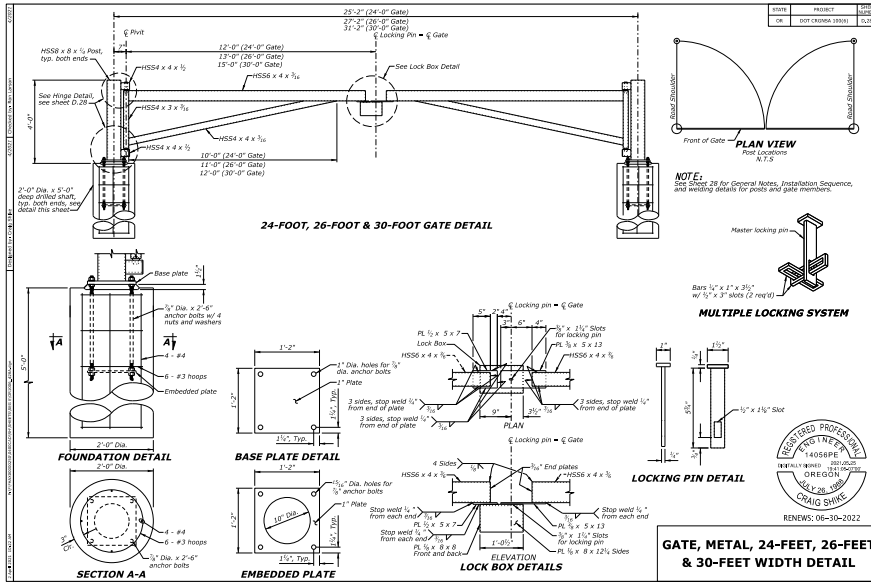

SWING GATE

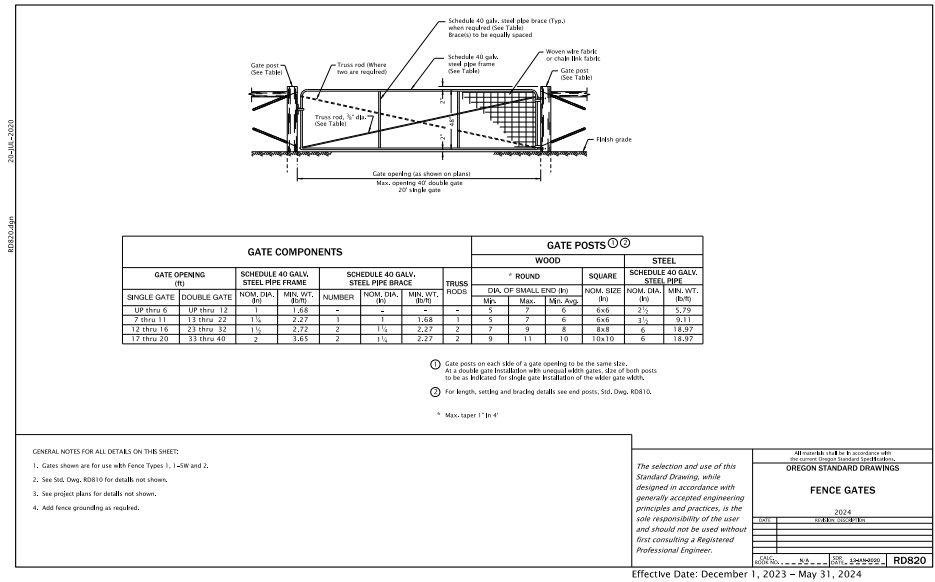

BENCH SEATING

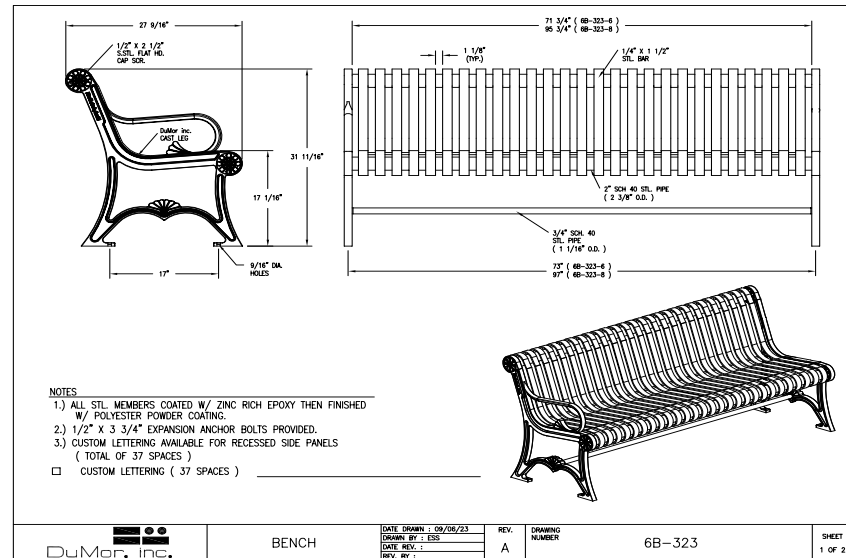

BENCH SEATING

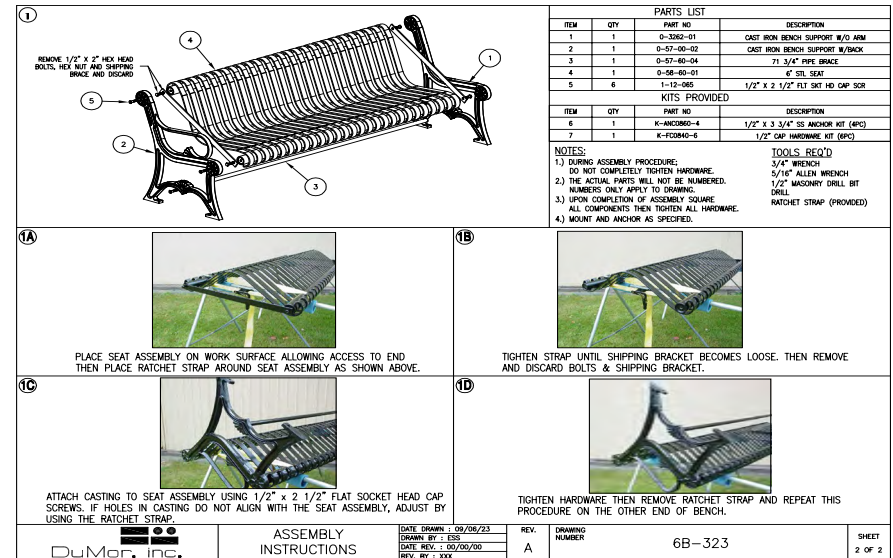

APPENDIX

BIKE RACK

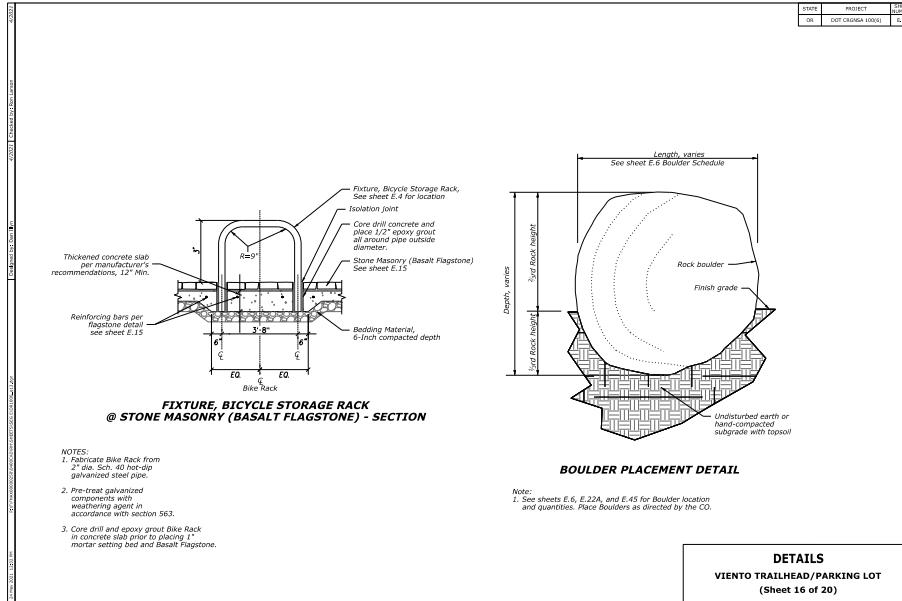

ADA PICNIC TABLE

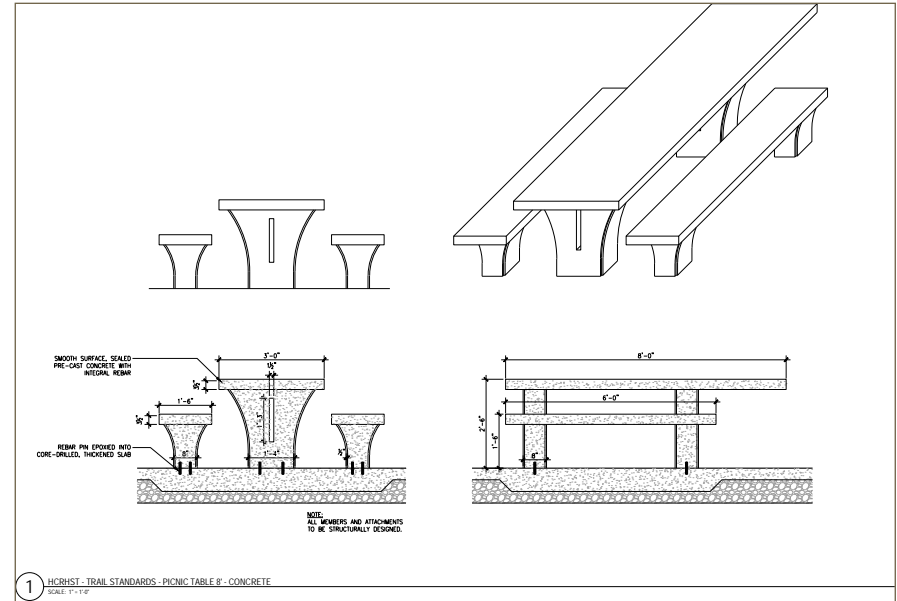

ADA PICNIC TABLE



APPENDIX

TRASH CONTAINER

RECEPTACLE

TRASH CAN, 1 DR LKBL, 32 GAL, SLATS, CUSTOM FLAT TOP



** Renderings are representations only. Wood grains and finishes may slightly vary **

SPECIFICATIONS

ITEM# D103928
DIA. 25-1/8"
HEIGHT 49-7/8"

FEATURES

- Steel construction (Black)
- Lockable
- Adjustable glides

IN PARTNERSHIP with Oregon Department of Corrections, our mission is to promote public safety by providing AICs with work and training opportunities in a self-sustaining organization. OCE believes strongly that second chances are created and earned through the work that we do.

800.776.7712
info@oce.oregon.gov
oce.oregon.gov
f t y



DETECTABLE WARNING PANEL

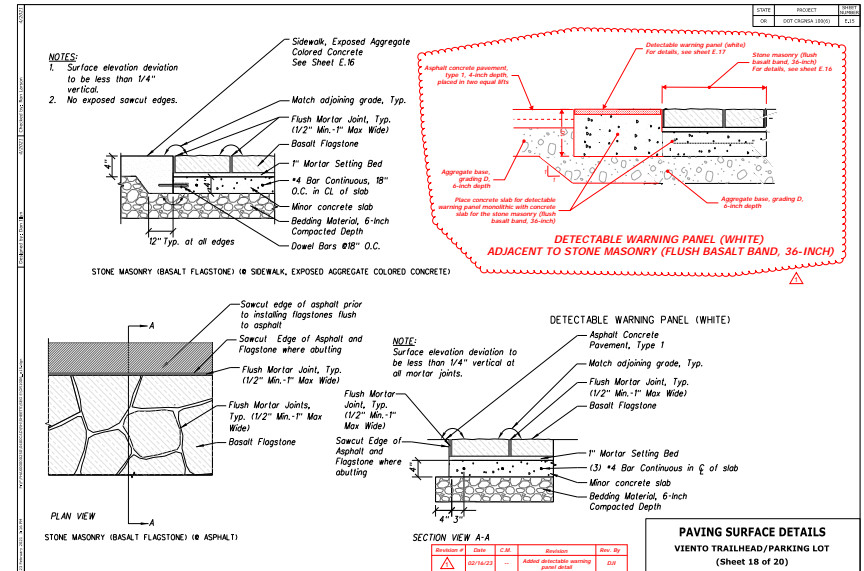

APPENDIX

STONE DETAILS

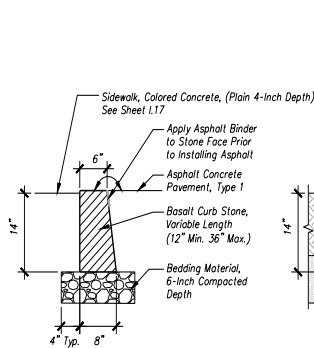

CURB STONE, TYPE 2, 14-INCH DEPTH (FLUSH)
 @Asphalt & Concrete
 SCALE: 1" = 1'-0"

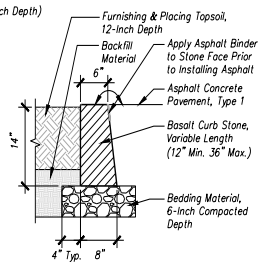

CURB STONE, TYPE 2, 14-INCH DEPTH (FLUSH)
 SCALE: 1" = 1'-0"

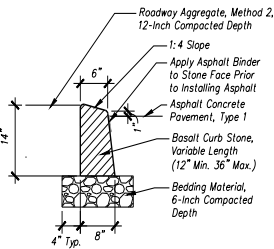

CURB STONE, TYPE 2, 14-INCH DEPTH (MOUNTABLE)
 SCALE: 1" = 1'-0"

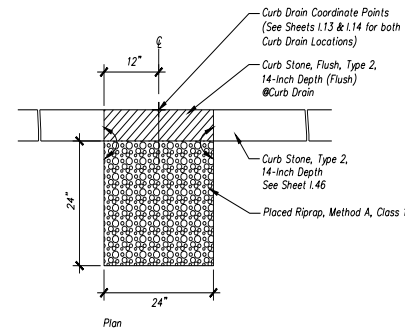

CURB STONE, TYPE 2, 14-INCH DEPTH (FLUSH)
 @Curb Drain
 SCALE: 1" = 1'-0"

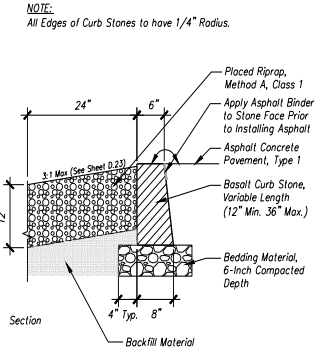

CURB STONE, TYPE 2, 14-INCH DEPTH (FLUSH)
 @Curb Drain
 SCALE: 1" = 1'-0"

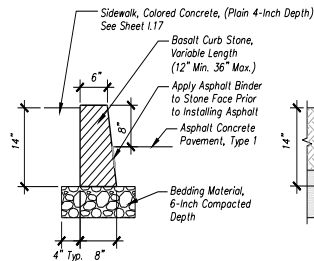

CURB STONE, TYPE 2, 14-INCH DEPTH
 @Asphalt & Concrete
 SCALE: 1" = 1'-0"

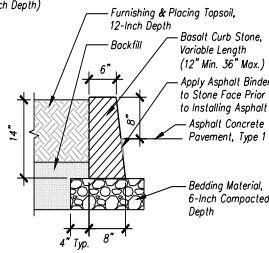

CURB STONE, TYPE 2, 14-INCH DEPTH
 SCALE: 1" = 1'-0"

NOTE:
 All Edges of Curb Stones to have 1/4" Radius.

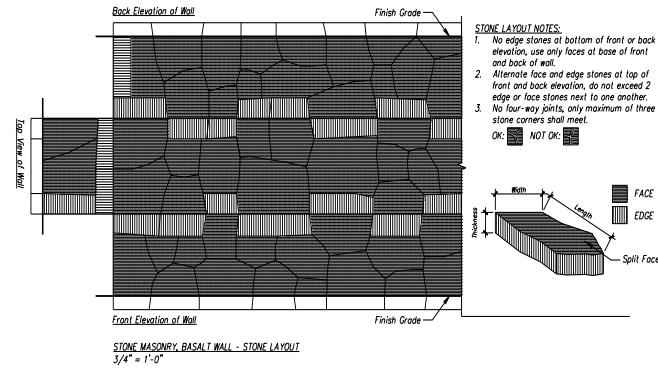
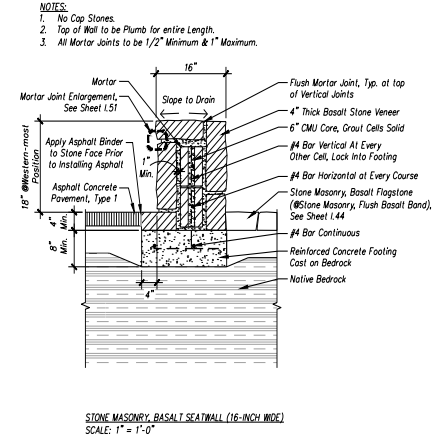
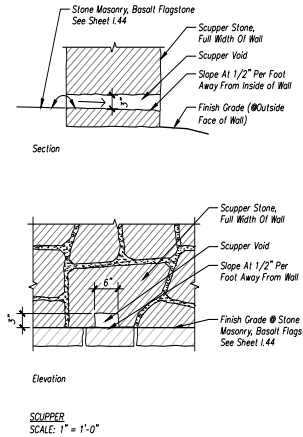
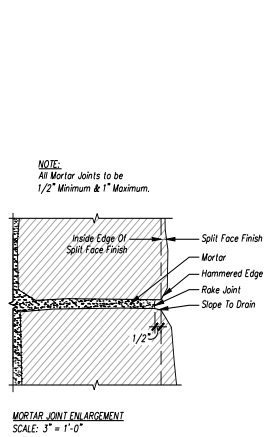

Historic Highway Advisory Committee 2024

				3/21/24 Meeting			6/20/24 Meeting			9/19/24 Meeting		12/12/24 Meeting	2025	
		January	February	March	April	May	June	July	August	September	October	November	December	
Historic Highway State Trail Projects	Perham - Mitchell Point State Trail													Construction 2026
	Mitchell Point Tunnel	Construction												
	Mitchell Point - Hood River State Trail	Design, Identify funding to construct												
	Trail mile markers	Design, Identify funding to implement												
	Eagle Creek Stair Mitigation													
	Historic Highway Projects	Summer 2024 Congestion Mitigation	Funding, agreements, staffing					Flagger, Traffic control, etc.						
Multnomah Falls Viaducts Upgrades		Construction 2024-'26												
Programmatic Agreement Modifications		Work with cities, start signature process												
Congestion and Safety Forum		Ongoing meetings, continue to pursue long-term vision/concept for the Gorge while addressing immediate congestion concerns												
Larch Mountain Slide Alternatives		Identify and apply for alternatives analysis funding												
Transit		Columbia Gorge Express transit CAT	Cat Coordination, pre-planning					Run Service						
	Gorge Transit Strategy													

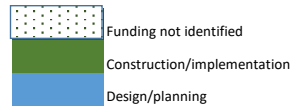

2024 Historic Columbia River Highway Advisory Committee Work Plan

Green shading = high priority

Yellow shading = medium priority

Category	Goal/Outcome	Actions	Draft Schedule	Deliverables
State Trail				
Perham to Mitchell Point	Complete construction	Work to accelerate funding to start construction before 2026	FLAP funding available starting 2026	
Mitchell Point Tunnel	Complete construction	Planning for opening celebrations	Construction started 2021 Construction complete early 2024	Completed Tunnel and trailhead Opening celebration
Mitchell Point to Ruthton Park	Complete design Complete construction	Transfer Ruthton Park from County to OPRD Identify funding for 100% design (FLAP) Identify construction funding (FLAP, NSFLTP)	NSFLTP application due 11/6, should hear mid-2024. Continue to pursue funding, as available	Grant application/funding request Final plans
Eagle Creek Stair Mitigation	<ul style="list-style-type: none"> - Address ADA barrier (stairs) - Clarify connections at Eagle Creek Campground 	<ul style="list-style-type: none"> - Scoping report review with partners - Identify funding - Apply for funding 	Alternatives analysis in 2024 (anticipated), identify funding for design and construction	Alternatives analysis, funding application(s)
Design Consistency Review	Create a consistent design over all segments of the State Trail to ensure it works as a cohesive whole	<ul style="list-style-type: none"> - Identify funding for ongoing maintenance to address areas in need of upgrading 		Project list Funding source

Category	Goal/Outcome	Actions	Draft Schedule	Deliverables
Emergency Trail Markers	Implement emergency trail markers acceptable with the State Trail design guidance	<ul style="list-style-type: none"> - Design and review acceptable trail markers for emergency services to access folks on the State Trail - Coordinate with EMS services to ensure they know where the markers are and how to access the State Trail 		
Viewshed management	Implement viewshed management on the State Trail	<ul style="list-style-type: none"> - Identify locations appropriate for viewshed/vegetation management - Identify funding to implement - Coordinate with partners to ensure viewsheds are appropriate 		
Historic Highway				
Multnomah Falls Viaducts Upgrades	Shore up load-limited viaducts to ensure continued utility	Coordination with UPRR Complete 100% plans	Construction 2024-2026	Upgraded viaducts
Congestion and Safety Implementation projects	Address congestion and safety concerns in the “waterfall alley”	Find funding for and implement projects from the Congestion and Safety Plan	Ongoing	Flagger at Multnomah Falls Long-term solution
Summer 2024 Congestion mitigation	Work with partners to reduce congestion and address safety concerns on the Waterfall Corridor, focusing on Multnomah Falls	Work with partners to implement Outreach/education effort to inform visitors, work with shuttles/transit to change travel behavior	Ongoing work through winter/spring, implement late May 2024	Mitigation actions/identify funding

Category	Goal/Outcome	Actions	Draft Schedule	Deliverables
Programmatic Agreement Modifications	Modify PAs with Cascade Locks, Hood River, and Mosier to update language and make consistent with adopted plans	Terminate and work with agency partners to update the programmatic agreements	Modify and sign updated agreements in 2024.	Updated PAs signed by all parties.
Larch Mountain Slide Alternatives	Address ancient landslide on the Historic Highway east of the Larch Mountain and HCRH intersection	Identify funding for alternatives analysis Complete concepts/alternative analysis	TBD – depends on funding	Alternatives analysis Grant application (FLAP?)
Congestion and Safety Forum	Continue coordination among partner agencies to ensure a coordinated approach to addressing congestion and safety issues in the Gorge	Coordination meetings	Ongoing	
Consistency Review for Drivable Historic Highway	Create a design update document similar to the State Trail consistency review	Identify funding for project, work to update the design aspect of the Historic Highway Master Plan		Consistency review document with a draft maintenance list to help use to identify and apply for funding.
Viewshed Management Plan	Update 2019 Viewshed plan to identify and implement recommendations	Coordinate with partners to ensure viewshed opening activities are consistent with NSA requirements, field visit, identify funding to implement viewshed/vegetation management		
Transit				

Category	Goal/Outcome	Actions	Draft Schedule	Deliverables
CGE service	Provide public transit access to Multnomah Falls	Continue coordination with CAT to enhance service to Multnomah Falls Work to integrate private shuttle providers into a cohesive system.	Winter 2023-spring 2024	Increased service
Funding				
NSFLTP	Provide funding to Nationally Significant Federal and Tribal Land	Track current proposal outcome Prepare for future opportunities	Applications due 11/6/2023, decisions mid-2024	Grant application
Infrastructure Investment and Jobs Act (IIJA)	Track new funding provided by the bill – work to secure some for the Historic Highway State Trail	Track discretionary funding grant opportunities	Ongoing	Identify appropriate grant applications
Equity				
Outreach	Engage populations that are interested, impacted, and that benefit from the Advisory Committee recommendations/ conversations. Ensure that a diversity of viewpoints are considered	Targeted community involvement to under-represented communities	Ongoing	
Committee membership	Ensure that the committee makeup reflects the communities impacted/ effected by the State Trail and Historic Highway	Recruit/identify interested members of the public to build a “deep bench” of supporters to tap when vacancies occur on the committee	Ongoing Hope to identify Multnomah County Governor’s rep in Spring	
Education and Communication				

Category	Goal/Outcome	Actions	Draft Schedule	Deliverables
Ready, Set, GOrge!	Provide information to visitors about how to responsibly visit the NSA	Website updates Valid information	Ongoing	Map updates Outreach updates
CGTA car-free transportation initiative	Update and provide itineraries to inform visitors of how to visit the Gorge car-free Identify future projects to enhance car-free opportunities	Review and update website, work with partners on additional initiatives to enhance car-free education, outreach, and opportunities	Spring/Summer 2024	Updated website, car-free itineraries
Governor/Legislative updates to new elected officials and OTC	Elected officials, including the new governor are aware of the State Trail and congestion issues Potential support or formal acknowledgement of the importance of the Historic Highway	OTC briefing Legislative briefing Governor briefing	Ongoing after January 2024	Provide materials on the State Trail and Congestion to decision-makers and their staff Hard hat tour(s) and site visits
Key initiatives/Priorities				
Representative Blumenauer's REC bill	An adopted Federal Bill with direction and funding to support sustainable recreation in the Gorge and Mt Hood	Track legislation at the federal level Continuing to work with Congressional Staff to modify bill, as needed	Winter/Spring 2024	Potentially an adopted bill

RESOLUTION OF THE OREGON TRANSPORTATION COMMISSION'S SUPPORT FOR COMPLETING THE HISTORIC COLUMBIA RIVER HIGHWAY STATE TRAIL PROJECT

RECITALS

WHEREAS, over a century ago, Samuel Hill and Samuel Lancaster envisioned America's first scenic highway, the Historic Columbia River Highway, to complement the Columbia Gorge's magnificent natural landscape.

WHEREAS, the Historic Columbia River Highway, constructed 1913-1922 through Multnomah, Hood River, and Wasco Counties, is considered one of the earliest and most significant scenic roads designed specifically for automobile use in the United States.

WHEREAS, The Historic Columbia River Highway is a National Historic Landmark recognized as an outstanding example of modern highway development in 20th century America for its pioneering advances in road design.

WHEREAS, the construction of a water-level route through the Columbia River Gorge, now Interstate 84, destroyed many sections of the Old Highway.

WHEREAS, the Oregon Department of Transportation was directed by Congress in the Columbia River Gorge National Scenic Area Act of 1986 (PL 99-663) to prepare a program to preserve and restore the Old Columbia River Highway for public use as an historic road.

WHEREAS, ORS366.551 directs the State of Oregon to connect intact and usable highway segments with recreation trails, where feasible, to create a continuous historic road route through the Columbia Gorge that links local, state, and federal recreation facilities.

WHEREAS, project partners have made considerable progress on reconnecting the Historic Columbia River Highway as a trail. There are only 1.6 miles of State Trail remaining to complete the full connection.

WHEREAS, in 2011 the Oregon Parks and Recreation Department adopted the Historic Columbia River Highway State Trail Plan. This plan defines the trail alignment and design guidelines which have been adopted by the Historic Columbia River Highway Advisory Committee. The trail is included in the Hood River County Transportation System Plan.

WHEREAS, there is broad public support for this project. The Gorge communities have rallied to support the completion of this project. They see tremendous economic opportunity created by bicycle tourism and the possibility of providing additional access to the gorge by means other than the automobile. A 2014 economic study prepared for Travel Oregon revealed that bike-related tourism brings \$46 million to the region annually.

WHEREAS, 21 miles of the Historic Columbia River Highway State Trail has been built. The remaining 1.6 miles of the trail are in the final design. Construction funding is needed to complete the project, which will connect the remaining segments of the old highway to the State Trail.

WHEREAS, the Oregon Trails Coalition has included the Historic Columbia River Highway State Trail as a Signature Trail in the state of Oregon and recognizes the historic, recreational, scenic, and statewide value of reconnecting the Historic Highway as the State Trail.

WHEREAS, the Oregon Transportation Commission recognizes the decades-long effort of the late William D. Pattison, as Chair of the Historic Highway Advisory Committee, State Trail Supporter, member of the Hood River Crag Rats, Hood River City Council member, and former Mayor of Hood River. May Mr. Pattison's passion and enthusiasm for outdoor recreation be shared by future State Trail users and enthusiasts.

WHEREAS, the Oregon Transportation Commission thanks the Historic Columbia River Advisory Committee for its continued leadership and dedication to completing construction of the Historic Columbia River Highway State Trail specifically the passion and dedication of former Chair, Mr. Wayne Stewart. Mr. Stewart's vision and willingness to advocate for the State Trail parallels the dedication and devotion of Samuel Lancaster.

WHEREAS, the Region 1 Area Commission on Transportation met in Hood River on August 7, 2023 to tour the Mitchell Point Tunnel and convened to approve a motion to urge the Oregon Transportation Commission to adopt this resolution.

NOW, THEREFORE, IT BE RESOLVED:

1. Constructing the final segments of the Historic Columbia River Highway State Trail is a project of statewide and national significance. Engineering is underway and all that remains is construction funding to complete the final trail segment between Mitchell Point Tunnel and Ruthton Park in Hood River.
2. The State of Oregon, local governments, and private citizens collaborated to leverage significant funding for improvements for the soon to be completed Mitchell Point Tunnel (Spring 2024) and Viento to Perham Creek segment (September 2023).
3. For the first time in 77 years, Oregonians are now able to ride their bicycles from Troutdale to Viento State Park without using the Interstate 84 shoulder.
4. Completing the Historic Columbia River Highway State Trail is a priority for the Oregon Department of Transportation, Oregon Parks and Recreation Department and Travel Oregon.
5. The Oregon Transportation Commission enthusiastically supports federal funding to complete the project and will communicate this in writing to the Oregon Congressional Delegation and the U.S. Department of Transportation.



6. The Oregon Transportation Commission directs the Oregon Department of Transportation to continue to develop federal funding requests and identify any required matching funds to take advantage of any grant opportunities.

7. This resolution shall be entered into the minutes and records of the Commission as Resolution No. [N/A], adopted on November 9, 2023.

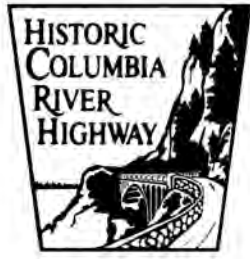

Friends of the Historic Columbia River Highway

PO Box 50, Bridal Veil, Oregon 97010

<http://www.hcrh.org>

December 7, 2023

Funding Commitments

HCRH State Trail Consistency and Enhancement Report – completed.

Recent Activities

Edgefield concerts – last one September 28.

Archeology Roadshow – November 18 – The Dalles

Upcoming activities

Presentation at Troutdale Historical Society – February 18

Portland Bicycle Club banquet

National Bike Summit – March 19-21

Jeanette vacation – April 22 – May 1

Presentation at Wasco County Historical Society – June 8

Gorge Ride – June 15, 2024

Antique car tour – July 13, 2024

Seeking additional Board members