

The Microscopic Particulate Analysis

The microscopic particulate analysis (MPA) is the method currently used in Oregon to determine whether a water system is under the influence of surface water. Source water that has been confirmed positive for *E. Coli* indicates that the water system may be at risk from *Giardia* and *Cryptosporidium* and therefore an MPA must be conducted. Surface water organisms such as diatoms, other algae, rotifers and insects are typically abundant in surface water. The MPA capitalizes on this occurrence, and, because diatoms and other algae are approximately the same size as *Giardia* (~10-15 microns¹), these organisms serve as useful surrogates for the potential occurrence of *Giardia* in the water.

MPAs are used to generate a relative risk factor for pathogenic organisms such as *Giardia* and *Cryptosporidium*. In some instances, surface water pathogens (*Giardia* and *Cryptosporidium*) are filtered out by the natural conditions of the soil and underlying sediment. *Giardia* and *Cryptosporidium* do not occur in all surface water all the time. Therefore, simply testing the water for the presence of these organisms may not be representative of the water people are drinking year-round. The MPA goes one step beyond testing the water alone and provides a mechanism to evaluate the natural filtration and the potential risk of pathogens in the drinking water source.

Conducting an MPA

Sampling for a microscopic particulate analysis is **not** like a typical “grab sample.” A grab sample requires that the water line is flushed and the sample bottle is filled. Collecting a sample for MPA is a carefully controlled procedure that requires specialized equipment operating over a period of at least eight hours — refer to the diagram below. The MPA sampling requires that a minimum of 500 gallons of water is directed at a rate of approximately 1 gallon per minute through a one-micron nominal cartridge filter. That filter captures all surface water organisms of that size and bigger. The filter is sent to the lab where it is examined under a microscope to identify the organisms present and their abundances. The MPA test then yields a “score” that depends on the type of surface water organisms present and their relative abundances. Refer to OAR 333-061-0032(7)(h) (Table 10: Modified Scoring for MPA).

MPA Sampling device

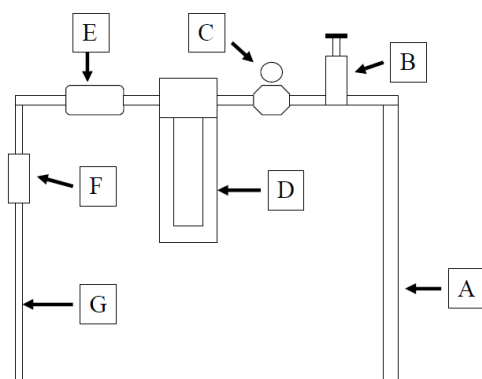

- A. Six-foot inlet hose with backflow preventer – (HG-80 female fittings)**
- B. Pressure regulator, adjustable, pre-set at 10 psi**
- C. Pressure gauge, 0-100 psi**
- D. MPA Consensus Method approved filter holder housing and propylene yarn filter**
- E. Gallon meter**
- F. Limiting flow orifice, 1 gpm (3.79 liters/minute)**
- G. Six-foot discharge hose**

For technical questions regarding the MPA and scoring please contact the OHA-DWS regional geologist for your area. Go [here](#) for contact information.

