

TECHNICAL SERVICE BRANCH  
TRAFFIC ROADWAY ENGINEERING SECTION  
ROADWAY ENGINEERING  
STANDARDS UNIT

---

Appendix "G"

---

**GUIDE  
TO  
CONTRACT PLANS  
STANDARD SYMBOLS  
FOR V8  
MICROSTATION**

ENGLISH EDITION - JUNE, 2011

ITEM	SYMBOL	FT=	TX=	WT=	CO=	LC=	AC=
<b>ALIGNMENT</b>							
Common & main				5	3	0	
Level	<i>P_RDWY_ALIGN_Main</i>						
Ramps				5	3	0	
Level	<i>P_RDWY_ALIGN_Main</i>						
Temp. conn. & detours				3	3	CL 1_V8	
Level	<i>P_RDWY_ALIGN_Detour</i>						
Frontage road				3	3	CL 1_V8	
Level	<i>P_RDWY_ALIGN_Minor</i>						
Channel change				5	3	CL 1_V8	
Level	<i>P_HY_WATER_ChannelCL</i>						
Future				5	3	CL 1_V8	
Level	<i>P_RDWY_ALIGN_Minor</i>						
Extg. & R/W				1	2	CL 1_V8	
Level	<i>E_SURV_ALIGN_Main Or P_RW_ALIGN_Prim</i>						
E. Bound & W. Bound when used with common $\mathcal{C}$				3		CL 1_V8	
Level	<i>P_RDWY_ALIGN_Main</i>						
Bikeway				4	3	CL 1_V8	
Level	<i>P_RDWY_ALIGN_Main</i>						

**NOTE:**

*Sta. labels to read ahead on line.*

*Station tics & label*

*For plotting 1" = 100'*

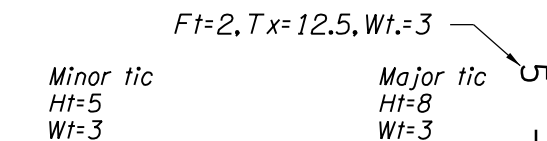

*For plotting 1" = 200'*

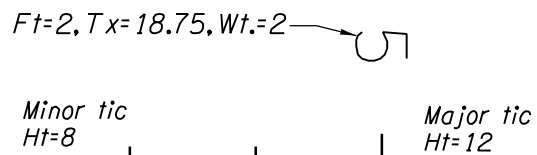

*NOTE: When a alignment line is also the center line of concrete barrier or median barrier. At the ends of each run on the plan sheet(s) or barrier run show 150' of the alignment line, with the middle showing the barrier.  
(For examples, see sheet AP11)*

ITEM	SYMBOL	FT=	TX=	WT=	CO=	LC=	AC=
<b>ALIGNMENT LABELS (Curve data, text)</b>							
<i>Common &amp; main</i>		24	7.5	2	3		
<i>Level</i>	<i>P_RDWY_ALIGN_MainTx</i>						
<i>Ramps</i>		24	7.5	2	3		
<i>Level</i>	<i>P_RDWY_ALIGN_RampTx</i>						
<i>Temp. conn. &amp; detours</i>		24	7.5	2	3		
<i>Level</i>	<i>P_RDWY_ALIGN_DetourTx</i>						
<i>Frontage road</i>		24	7.5	2	3		
<i>Level</i>	<i>P_RDWY_ALIGN_MinorTx</i>						
<i>Channel change</i>		24	7.5	2	3		
<i>Level</i>	<i>P_HY_WATER_ChannelCLTx</i>						
<i>Future</i>		24	7.5	2	3		
<i>Level</i>	<i>P_RDWY_ALIGN_MinorTx</i>						
<i>Extg. &amp; R/W</i>		24	6.3	1	2		
<i>Level</i>	<i>P_RDWY_ALIGN_MinorTx</i>						
<i>E. Bound &amp; W. Bound when used with common C</i>		24	7.5	2	3		
<i>Level</i>	<i>P_RDWY_ALIGN_MainTx</i>						
<i>Bikeway</i>		24	7.5	2	3		
<i>Level</i>	<i>P_RDWY_ALIGN_MainTx</i>						
<i>Bearing</i>	<i>N. 8°08'28" E.</i>	24	7.5	2	3		
<i>Level</i>	<i>P_RDWY_ALIGN_MainTx</i>						
<i>Alignment label</i>	<i>"Z" LINE</i>	2	12.5	3	3		
<i>Level</i>	<i>P_RDWY_ALIGN_General</i>						
<i>Flagged control points</i>	<i>"Z" 102+58 P.T.</i>	24	7.5	2	3		
<i>Level</i>	<i>P_RDWY_ALIGN_MainTx</i>						

**ALIGNMENT, DATA**

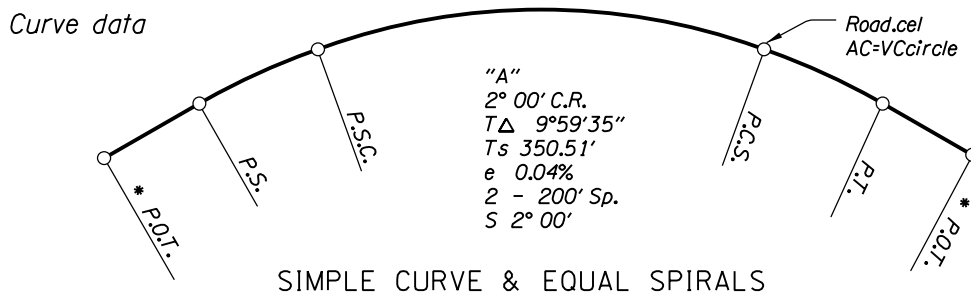

\* P.O.B. & P.O.E. to be changed to P.O.T., P.O.C. or P.O.S.

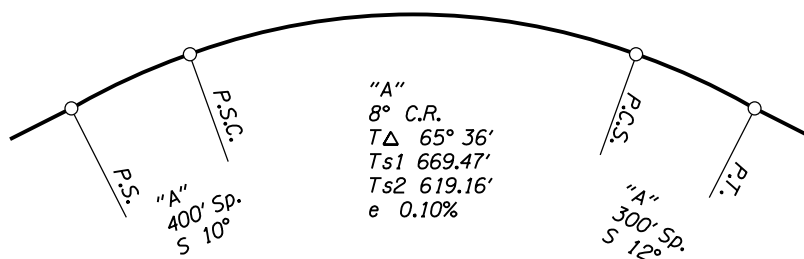

SIMPLE CURVE & UNEQUAL SPIRALS

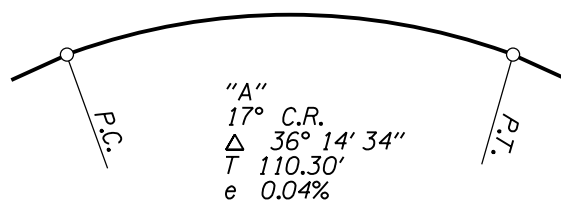

SIMPLE CURVE

**NOTES:**

1. For level, see Sht. 1, alignment label
2. For  $T_x$  &  $W_t$ , see Sht. 1, station tics and label
3. When curve data covers 2 or more shts., place curve data on the shts. that it appears on.

(FONT 24 characters)

Note: Degree symbol = (Shift)(Caret)	(°)
Delta symbol = (Shift)(<)	( $\Delta$ )
Angle point symbol = (Shift)(l)	( $\sphericalangle$ )
Center line symbol = (Shift)(l)	( $\text{\textcircled{C}}$ )
Plus or minus symbol = (Shift)(:)	( $\pm$ )

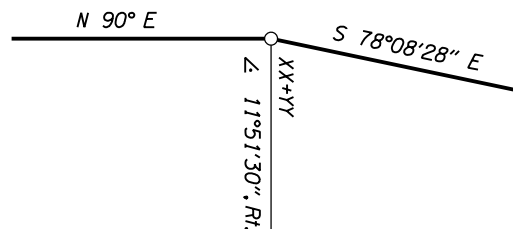

ANGLE POINT

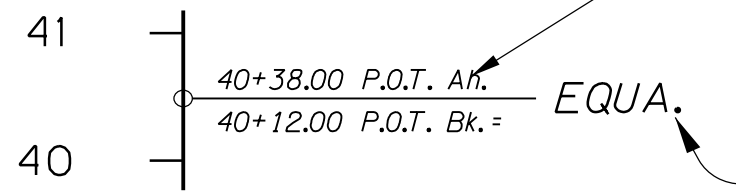
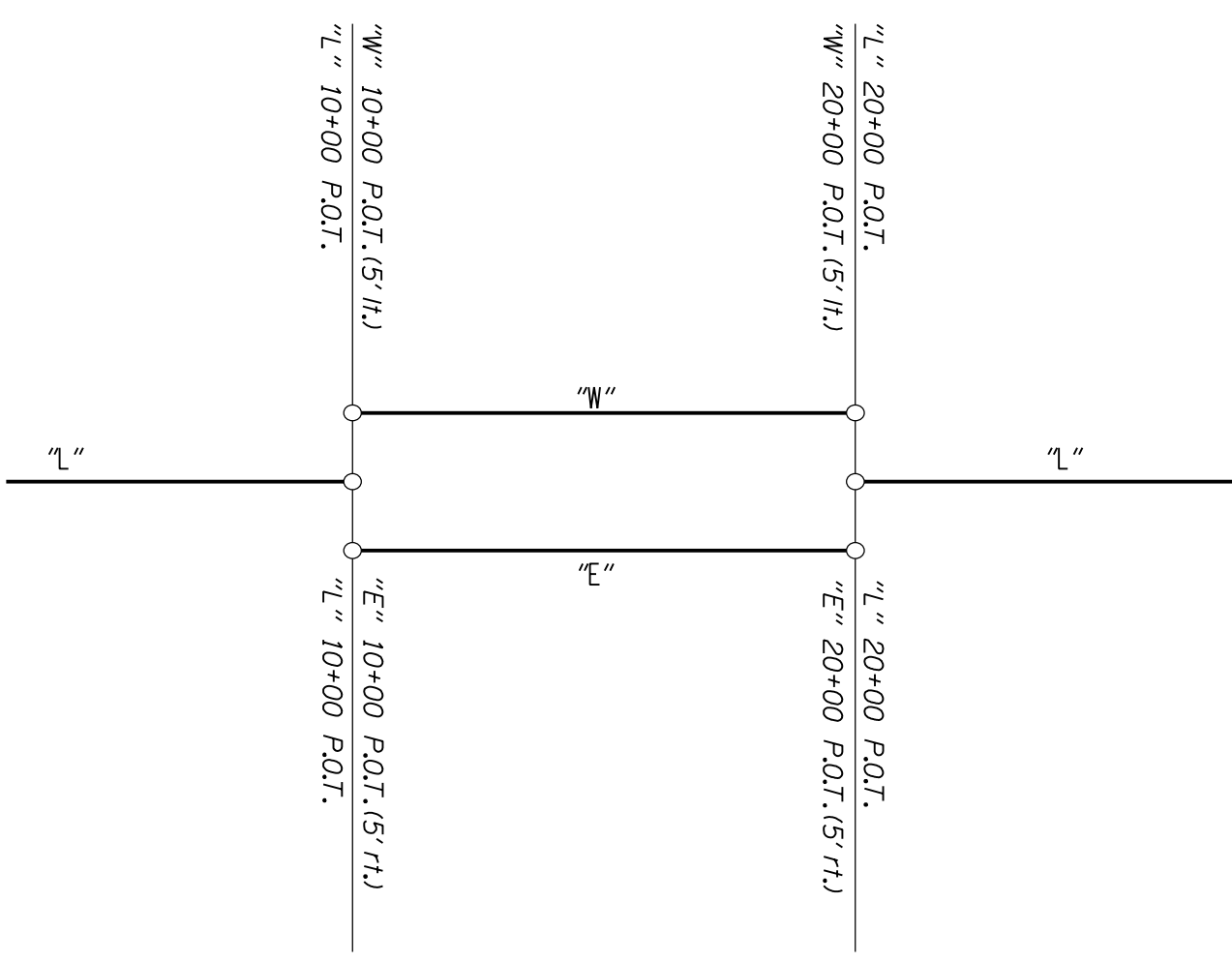
ITEM	SYMBOL	FT=	TX=	WT=	CO=	LC=	AC=
<b>ALIGNMENT, DATA</b>							
<i>Equation</i>							
<i>Label</i>	24 7.5 2 3						
41  40	40+38.00 P.O.T. Ah. 40+12.00 P.O.T. Bk.=	24	7.5	2	3	<i>To be read ahead on line</i>	
<i>Level</i>	P_RDWY_ALIGN_MainTx						
<b>HORIZONTAL OFFSET</b>							
<i>Label</i>	24 7.5 2 3						
<i>Level</i>	P_RDWY_ALIGN_MainTx						
							

ITEM	SYMBOL	FT=	TX=	WT=	CO=	LC=	AC=
------	--------	-----	-----	-----	-----	-----	-----

**APPROACH, CONST.**

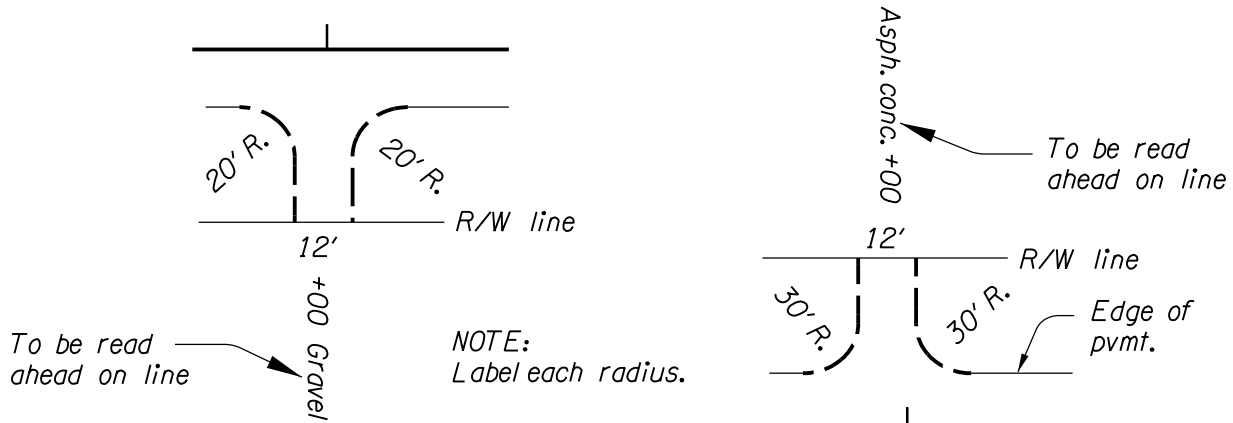

				5	3	approach const_V8	
Level	P_RDWY_ROAD_Approach						
Label		24	7.5	2	3		
Level	P_RDWY_ROAD_GeneralTx						
Const. note	Const. appr.						
Level	P_RDWY_PLAN_NotesTx						

**APPROACH, EXISTING**

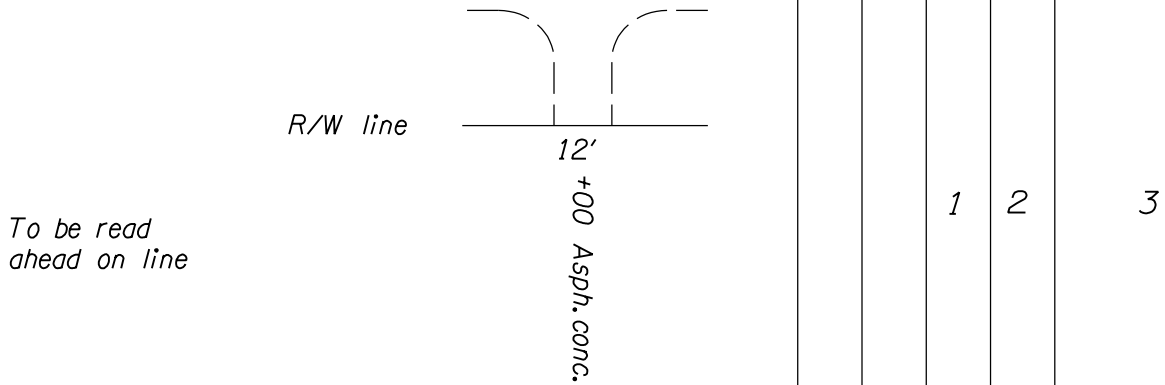











					1	2	3
Level	E_RDWY_ROAD_Approach						
Label		24	7.5	2	2		
Level	E_RDWY_ROAD_GeneralTx						





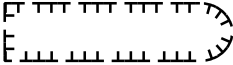

**ACCESS ROAD, CONST.**

	-----				1	3	2
Level	P_RDWY_ROAD_EdgeAsph						
Const. note	Const. access road						
Level	P_RDWY_PLAN_NotesTx						

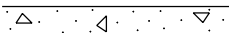
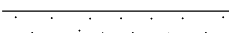

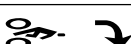
ITEM	SYMBOL	FT=	TX=	WT=	CO=	LC=	AC=
<b>BACKSIGHT CHECK, EXTG.</b>							
	☑			1	0	bschk	
Level	E_SURV_MON_BS						
Extg. elev.	65.34'	24	6.3	1	0		
Level	E_SURV_MON_BStx						
<b>BARRICADE, PORTABLE CONST.</b>							
	]			3	3	brcade	
Level	P_RDWY_ROAD_Barrier						
<b>BARRIER, CONST.</b>							
Conc. median	=====			3	3	barrier median_v8	
Conc. shoulder	=====			3	3	barrier shldr_v8	
Metal median	-■-■-■-■-■-■-■-■-■-■-			3	3	gr med c_v8	
Cable barrier	- _ _ _ _ _ _ _ _ _ _ _ -			3	3		
Level	P_RDWY_ROAD_Barrier						
Const. note	Sta. 69+00 to Sta. "A" 72+65, Lt. Const. precast conc. narrow base shldr. barrier - 365.76' Pin barrier Grout barrier Const. transition Flare rate=0, W=0, E=2' Connect to guardrail (For details, see sht. 2B-?) (See drg. nos. RD500 & RD530)	24	7.5	2	3	NOTE: If barrier is located on the center line. At each end of the sheet show 150' of center line then 150' of barrier, in middle show center line.	
Level	P_RDWY_PL AN_NotesTx						
<b>BARRIER, EXISTING</b>							
Conc. median	=====			1	0		
Conc. shoulder	=====			1	0		
Metal median	-□-□-□-□-□-□-□-□-□-□-			1	2	gr med e_v8	
Cable barrier	- _ _ _ _ _ _ _ _ _ _ _ -			1	2		
Level	E_RDWY_ROAD_Barrier						
Label	Conc. shldr. barrier	24	6.3	1	0		
Level	E_RDWY_ROAD_Generaltx						
NOTE: Survey will show a single line for extg. barrier and note which side the shot was taken. The Drafter will copy parallel for the width.							

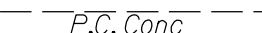
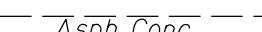



ITEM	SYMBOL	FT=	TX=	WT=	CO=	LC=	AC=
<b>BEACON, FLASHING, CONST.</b>							
				3	5	flash1	
				3	5	flash2	
				3	5	flash3	
				3	5	flash4	
Level	P_TRAF_SIGNAL_Equipment						
Const. note	Inst. 2-way flashing beacon (By others)	24	7.5	2	3		
Level	P_RDWY_PLAN_NotesTx						
<b>BEACON, FLASHING, EXTG.</b>							
				1	5	flash1	
				1	5	flash2	
				1	5	flash3	
				1	5	flash4	
Level	E_TRAF_SIGNAL_Equipment						
<b>BENCH MARK CONST.</b>							
				3	4	Setbm	
	 Lower case c	84	6.3	1	4		
Level	E_SURV_MON_SetBm						
Const. note	Const. benchmark	24	7.5	2	3		
Level	P_RDWY_PLAN_NotesTx						
<b>BENCH MARK EXTG.</b>							
				1	4	Fdbm	
Level	E_SURV_MON_FdBM						
Label		24	6.3	1	4		
Level	E_SURV_MON_FdBMTx						
<b>BERM (EARTH), CONST.</b>							
				3	3	berm_V8	
Level	P_RDWY_ROAD_Berm						
Const. note	Const. earth mound	24	7.5	2	3		
Level	P_RDWY_PLAN_NotesTx						

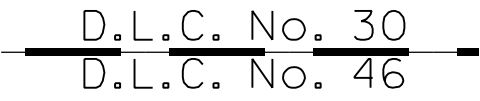
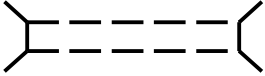
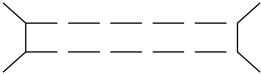

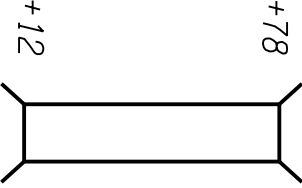

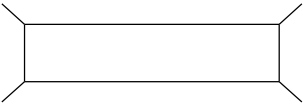



ITEM	SYMBOL	FT=	TX=	WT=	CO=	LC=	AC=
<b>BERM (EARTH), EXTG.</b>							
				1	3		berm_V8
Level	E_RDWY_ROAD_Berm						
Label		24	6.3	1	3		
Level	E_RDWY_ROAD_GeneralTx						
<b>BIKEWAY CONST.</b>							
ap=Pat_Conc	P.C. conc. 			1	3		0
ap=Pat_Stip or Pat_Eperiod	Asph. conc. 			1	3		0
Level	P_RDWY_ROAD_Bikeway						
Const. note	Const. bikeway	24	7.5	2	3		
Level	P_RDWY_PL AN_NotesTx						
<b>BIKEWAY SYMBOL</b>							
StripeV8.cel		ac=Bike_ARROW_LT					
		ac=Bike_ARROW_RT					
		ac=Bike_ARROW_STR					
Level	P_RDWY_ROAD_Striping						
<b>BIKEWAY EXTG.</b>							
				1	2		3
				1	2		3
Level	E_RDWY_ROAD_Bikeway						
Label		24	6.3	1	2		
Level	E_RDWY_ROAD_GeneralTx						
<b>BOLLARD, CONST.</b>							
	R = 2' 			3	0		Bollard_C
Level	P_RDWY_ROAD_Bollard						
Const. note	Inst. bollard - 2	24	7.5	2	3		
Level	P_RDWY_ROAD_NotesTx						



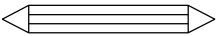
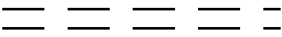
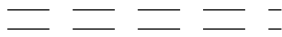

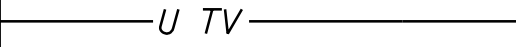
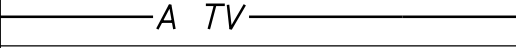
ITEM	SYMBOL	FT=	TX=	WT=	CO=	LC=	AC=
<b>BOLLARD, EXTG.</b>							
	<i>R = 2'      ○</i>			1	0	<i>bollard</i>	
<i>Level</i>	<i>E_RDWY_ROAD_Bollard</i>						
<i>Label</i>		24	6.3	1	0		
<i>Level</i>	<i>E_RDWY_ROAD_GeneralTx</i>						
<b>BOUNDARIES</b>							
<i>Level</i>	<i>State line</i>						
<i>E_SURV_BNDRY_GovStateTx</i>	<b>OREGON</b> -----	2	15.6	5	6		
<i>E_SURV_BNDRY_GovState</i>				5	6	<i>state_V8</i>	
<i>Level</i>	<i>County line</i>						
<i>E_SURV_BNDRY_GovCountyTx</i>	<b>BAKER</b> -----	2	12.5	3	6		
<i>E_SURV_BNDRY_GovCounty</i>				3	6	<i>county_V8</i>	
<i>Level</i>	<i>City limits</i>						
<i>E_SURV_BNDRY_GovCityTx</i>	<i>Salem City Limits</i> .....	24	7.5	2	6		
<i>E_SURV_BNDRY_GovCity</i>				2	6	<i>city_V8</i>	
<i>Level</i>	<i>Township &amp; Range</i>						
<i>E_SURV_BNDRY_GovTownshipTx</i>	T. 1 S., R. 1 E., W.M. -----	2	12.5	3	6		
<i>E_SURV_BNDRY_GovTownship</i>				5	6	0	
<i>Level</i>	<i>Section Line</i>						
<i>E_SURV_BNDRY_GovSectionLineTx</i>	Sec. 30 <i>To read</i> ----- <i>North</i> Sec. 31	2	12.5	3	6		
<i>E_SURV_BNDRY_GovSectionLine</i>				3	6	0	
<i>1/4 Section Line</i>	-----			2	6	<i>quarter_V8</i>	
<i>Level</i>	<i>E_SURV_BNDRY_GovQuartSectLine</i>						
<i>1/16 Line</i>	-----			1	6	<i>sixsec_V8</i>	
<i>Level</i>	<i>E_SURV_BNDRY_GovSixSectLine</i>						
<i>D.L.C. Line, left</i>	-----			1	6	<i>dlc1_V8</i>	
<i>Level</i>	<i>E_SURV_BNDRY_GovDLCLine</i>						
<i>D.L.C. Line, right</i>	-----			1	6	<i>dlc2_V8</i>	
<i>Level</i>	<i>E_SURV_BNDRY_GovDLCLine</i>						

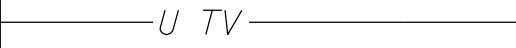
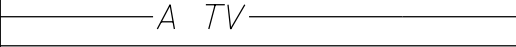
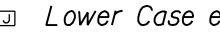

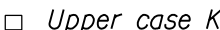
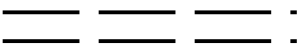

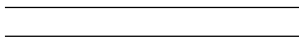
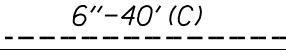
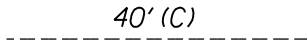
ITEM	SYMBOL	FT=	TX=	WT=	CO=	LC=	AC=
<b>BOUNDARIES CONTD.</b>							
<i>Level</i>	<i>D.L.C. line, both</i>						
<i>E_SURV_BNDRY_GovDLCLineTx</i>		2	9.4	2	6		
<i>E_SURV_BNDRY_GovDLCLine</i>				1	6	<i>dlc3_V8</i>	
<b>BOX CULVERT, CONST.</b>							
				5	3		3
<i>Level</i>	<i>P_HY_WATER_Structure</i>						
<i>Const. note</i>	<i>Const. 6' x 8' R.C.B.C. - 60'</i>	24	7.5	2	3		
<i>Level</i>	<i>P_RDWY_PLAN_NotesTx</i>						
<b>BOX CULVERT, EXTG.</b>							
				1	0		3
<i>Level</i>	<i>E_HY_WATER_Structure</i>						
<i>Label</i>	<i>6' x 6' R.C.B.C</i>	24	6.3	1	0		
<i>Level</i>	<i>E_HY_WATER_StructureTx</i>						
<b>BREAKLINES, EXTG.</b>							
				0	2		0
<i>Level</i>	<i>E_TERR_DTM_BrkLines</i>						
<b>BRIDGE (STRUCTURE), CONST.</b>							
				5	3		0
<i>Level</i>	<i>P_BR_SUPER_General</i>						
<i>Const. note</i>	<i>Bridge no. WXYZ Const. structure - 40' Rdwy. width 13.41' with 8' walk, lt. And reinf. panel at bridge ends (For drg. nos., see sht. 1)</i>	24	7.5	2	3		
<i>Level</i>	<i>P_RDWY_PLAN_NotesTx</i>						

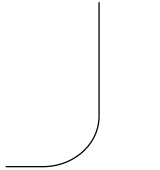
ITEM	SYMBOL	FT=	TX=	WT=	CO=	LC=	AC=
<b>BRIDGE (STRUCTURE), EXTG.</b>							
				1	0		0
<i>Level</i>	<i>E_BR_SUPER_General</i>						
<i>Label</i>	# & Name	24	6.3	1	0		
<i>Level</i>	<i>E_BR_SUPER_Tx</i>						
<b>BRIDGE END PANEL, CONST.</b>							
				2	3		0
<i>Level</i>	<i>P_BR_SUPER_General</i>						
<b>BRIDGE END PANEL, EXTG.</b>							
				1	0		0
<i>Level</i>	<i>E_BR_SUPER_General</i>						
<i>Label</i>	# & Name	24	6.3	1	0		
<i>Level</i>	<i>E_BR_SUPER_Tx</i>						
<b>Bridge Details Checked Changed To STRUCTURAL DETAILS CHECKED</b>							
	STRUCTURAL DETAILS CHECKED _ _ _ _ _						<i>SDC</i>
<i>Level</i>	<i>P_RDWY_PLAN_NotesTx</i>						
<i>This cell is in PlansV8.dgn and is to be placed on the left side of all Roadway plan sheets that have bridge and wall information on them.</i>							
<b>BRUSH LINE, EXTG.</b>							
				1	2		<i>brush line_V8</i>
<i>Level</i>	<i>E_LDSC_VEG_Planted</i>						
<i>Label</i>	# & Name	24	6.3	1	2		
<i>Level</i>	<i>E_LDSC_VEG_GeneralTx</i>						

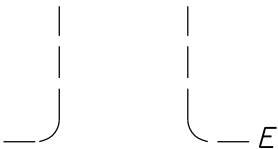
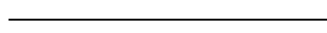

ITEM	SYMBOL	FT=	TX=	WT=	CO=	LC=	AC=
<b>BUILDING, EXTG.</b>							
				1	2	0	
<i>Level</i>	<i>E_RDWY_BLDG_General</i>						
<i>Label</i>	<i>Two story house 123 Street Ave. N.E. City, Or. 97XXX</i>	24	6.3	1	2		
<i>Level</i>	<i>E_RDWY_BLDG_GeneralTx</i>						
<b>CATTLE GUARD, CONST.</b>							
				3	3	0	
<i>Level</i>	<i>P_RDWY_ROAD_Cattlepass</i>						
<i>Const. note</i>	<i>Const. cattle guard</i>	24	7.5	2	3		
<i>Level</i>	<i>P_RDWY_PLAN_NotesTx</i>						
<b>CATTLE GUARD, EXTG.</b>							
				1	3	0	
<i>Level</i>	<i>E_RDWY_ROAD_Cattlepass</i>						
<b>CATTLE PASS, CONST.</b>							
				3	3	<i>cattle</i>	<i>pass_V8</i>
<i>Level</i>	<i>P_RDWY_ROAD_Cattlepass</i>						
<i>Const. note</i>	<i>Const. cattle pass</i>	24	7.5	2	3		
<i>Level</i>	<i>P_RDWY_PLAN_NotesTx</i>						
<b>CATTLE PASS, EXTG.</b>							
				1	2	<i>cattle</i>	<i>pass_V8</i>
<i>Level</i>	<i>E_RDWY_ROAD_Cattlepass</i>						
<i>Label guard or pass (Extg.)</i>		24	6.3	1	2		
<i>Level</i>	<i>E_RDWY_ROAD_GeneralTx</i>						

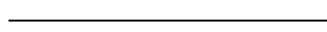

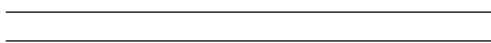

ITEM	SYMBOL	FT=	TX=	WT=	CO=	LC=	AC=
<b>CATV UTILITIES, CONST.</b>							
CATV line (Under ground)				3	6	ug TV_V8	
Level	P_UTIL_COMM_UGLine						
CATV line (Above ground)				3	6	ag TV_V8	
Level	P_UTIL_COMM_OHLine						
Const. note	Inst. TV cable (By others)	24	7.5	2	3		
Level	P_RDWY_PLAN_NotesTx						
CATV riser				3	6	risut	
		84	6.3	3	6		
Level	P_UTIL_COMM_General						
Const. note	Inst. TV cable riser (By others)	24	7.5	2	3		
Level	P_RDWY_PLAN_NotesTx						
<b>CATV UTILITIES, EXTG.</b>							
CATV line (Under ground)				1	6	ug TV_V8	
Level	E_UTIL_COMM_UGLine						
CATV line (Above ground)				1	6	ag TV_V8	
Level	E_UTIL_COMM_OHLine						
CATV junction box		84	6.3	1	6		
CATV riser				1	6	risut	
		84	6.3	1	6		
Level	E_UTIL_COMM_General						
Label	CATV riser	24	6.3	1	6		
Level	E_UTIL_COMM_GeneralTx						
<b>CENTER LINES</b>	See sht. 1, alignments						
<b>CHANNEL CHANGE, CONST.</b>							
				5	3	channel change_V8	
Level	P_HY_WATER_ChannelCL						
Const. note	Const. channel change 4' bottom, 1:2 slopes Dt. exc. - 15 cu. yd.	24	7.5	2	3		
Level	P_RDWY_PLAN_NotesTx						

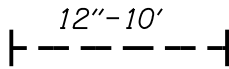
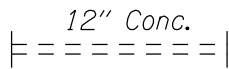
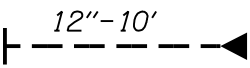
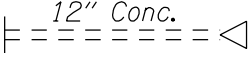



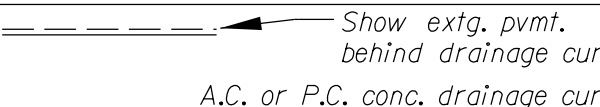
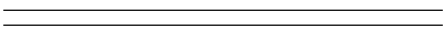

ITEM	SYMBOL	FT=	TX=	WT=	CO=	LC=	AC=
<b>CHANNEL, EXTG.</b>							
				1	1	0	
Level	E_HY_WATER_ChannelCL						
Label		24	6.3	1	1		
Level	E_HY_WATER_ChannelCLTx						
<b>CONDUIT CONST.</b>							
				3	3	pipe	const_V8
Level	P_HY_STORM_Pipe						
Descriptive text	P_HY_STORM_FlowTx						
Const. note	Inst. 6" culv. pipe - 40' (Conduit)	24	7.5	2	3		
Level	P_RDWY_PLAN_NotesTx						
<b>CONDUIT EXTG.</b>							
				1	3	pipe	const_V8
Level	E_HY_STORM_Pipe						
Descriptive text	E_HY_STORM_PipeTx						
Label		24	6.3	1	2		
Level	E_HY_STORM_Pipe						
<b>CONFIDENCE POINTS</b>							
Using font 84	 Upper Case J	84	6.3	1	2	3	
Level	E_TERR_DTM_ConfPt						
<b>CONNECTION, CONST. (Road or Street)</b>							
				1	3	0	
	 Edge of travel lane						
Level	P_RDWY_ROAD_Approach						
Const. note	Const. road connection	24	7.5	2	3		
Level	P_RDWY_PLAN_NotesTx						

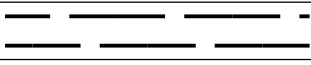
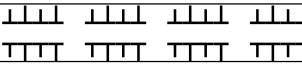

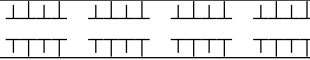
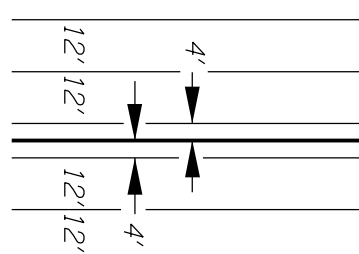
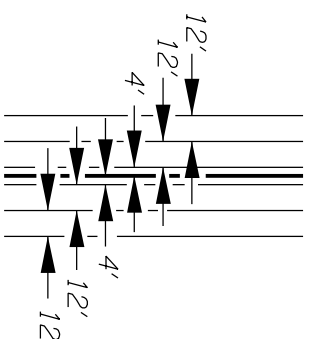











ITEM	SYMBOL	FT=	TX=	WT=	CO=	LC=	AC=
<b>CONNECTION, EXTG. (Road or Street)</b>							
	 <p style="text-align: right;">— Edge of pvmt.</p>			1	2	3	
Level	<i>E_RDWY_ROAD_Approach</i>						
Label	N.W. FLANDERS ST.	2	9.4	2	2		
Level	<i>E_RDWY_ROAD_GeneralTx</i>						
<b>CONTOURS, Proposed</b>							
Major				3	7	0	
Level	<i>P_TERR_DSPL AY_MajContour</i>						
Minor				1	0	0	
Level	<i>P_TERR_DSPL AY_MinContour</i>						
Text	250	2	6.3	2	7		
Level	<i>P_TERR_DSPL AY_GeneralTx</i>						
<b>CONTOURS, Existing</b>							
Major				2	18	<i>pro</i>	<i>subgrade_V8</i>
Level	<i>E_TERR_DSPL AY_MajContour</i>						
Minor				0	9	<i>pro</i>	<i>subgrade_V8</i>
Level	<i>E_TERR_DSPL AY_MinContour</i>						
Text	250	2	6.3	2	9		
Level	<i>E_TERR_DSPL AY_GeneralTx</i>						
<b>CREEK</b>							
				1	1	0	
Level	<i>E_HY_WATER_Edge</i>						
Label, large	ELEPHANT CREEK	24	6.3	1	1		
Label, small	Rickreall Cr.	24	6.3	1	1		
Level	<i>E_HY_WATER_GeneralTx</i>						
<b>CROSSWALK, EXTG.</b>							
				1	0	0	
Level	<i>E_RDWY_ROAD_Striping</i>						



ITEM	SYMBOL	FT=	TX=	WT=	CO=	LC=	AC=
<b>CULVERT PIPE CONST.</b>							
<i>Label only if more than one run in note</i>	 12"-10'	24	7.5	2	3	<i>pipe const_V8 &amp; It=PipeEndC</i>	
				5	3		
<i>Level</i>	<i>P_HY_STORM_Pipe</i>						
<i>Size/Type text</i>	<i>P_HY_STORM_PipeTx</i>						
<i>Descriptive text</i>	<i>P_HY_STORM_FlowTx</i>						
<i>Const. note</i>	<i>Inst. 12" culv. pipe - 10'</i>	24	7.5	2	3		
<i>Level</i>	<i>P_RDWY_PLAN_NotesTx</i>						
<b>CULVERT PIPE, EXTG.</b>							
	 12" Conc.	24	6.3	1	1	<i>pipe extg_V8 &amp; It=Pipeend</i>	
				1	1		
<i>Level</i>	<i>E_HY_STORM_Pipe</i>						
<i>Size text</i>	<i>E_HY_STORM_PipeTx</i>						
<i>Flow text</i>	<i>E_HY_STORM_DescriptiveTx</i>						
<b>CULVERT PIPE WITH PAVED END SLOPE, CONST.</b>							
	 12"-10'	24	7.5	2	3	<i>It=PEslopeC &amp; It=PipeendC</i>	
				5	3		
<i>Level</i>	<i>P_HY_STORM_Pipe</i>						
<i>Const. note</i>	<i>Const. paved end slope</i>	24	7.5	2	3		
<i>Level</i>	<i>P_RDWY_PLAN_NotesTx</i>						
<b>CULVERT PIPE WITH PAVED END SLOPE, EXTG.</b>							
	 12" Conc.	24	6.3	1	1	<i>It=Pipeend &amp; It=PipePav</i>	
				1	1		
<i>Level</i>	<i>E_HY_STORM_Pipe</i>						
<i>Label</i>	<i>E_HY_STORM_PipeTx</i>						
<b>CURB, CONST.</b>							
				4	3	<i>Curb const_V8</i>	
<i>Level</i>	<i>P_RDWY_ROAD_Curb</i>						
<i>Const. note</i>	<i>Const. standard curb</i> <i>Const. P.C. conc. drainage curb</i>	24	7.5	2	3		
<i>Level</i>	<i>P_RDWY_PLAN_NotesTx</i>						

ITEM	SYMBOL	FT=	TX=	WT=	CO=	LC=	AC=
<b>CURB, EXTG.</b>							
(Top back curb NOT be shown on plans)				1	2	0	
				1	2	0	
				1	2	0	
Level	E_RDWY_ROAD_Curb						
Label	Label all except standard	24	6.3	1	2		
Level	E_RDWY_ROAD_GeneralTx						
<b>DAM, EXTG.</b>							
				1	1	0	
Level	E_GT_WALL_General						
Label	DETROIT DAM	24	6.3	1	1		
Level	E_GT_WALL_GeneralTx						
<b>DESTINATION, CONST. &amp; EXTG.</b>							
				1	3	0	
Label	(Arrow from ODOT.General)	24	7.5	2	3	It=Dimarrow	
Level	P_RDWY_PLAN_DetailTx						
<b>DETOUR</b>							
				5	3	detour EP_V8	
Level	P_RDWY_ROAD_Detour						
Const. note	Const. detour	24	7.5	2	3		
Level	P_RDWY_PLAN_NotesTx						
<b>DIKE, CONST.</b>							
				3	3	dike_V8	
Level	P_HY_WATER_Structure						
Const. note	Const. dike	24	7.5	2	3		
Level	P_RDWY_PLAN_NotesTx						

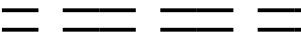



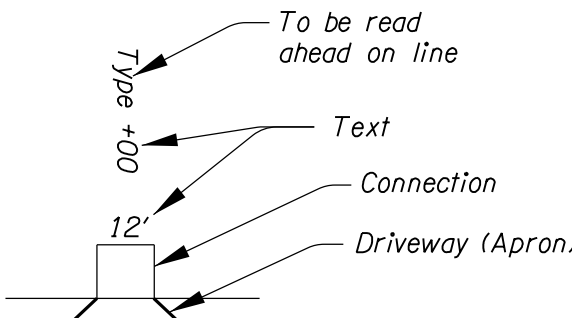
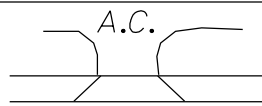

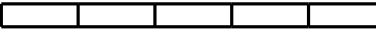

ITEM	SYMBOL	FT=	TX=	WT=	CO=	LC=	AC=
<b>DIKE, EXISTING</b>							
				1	1	<i>dike_v8</i>	
<i>Level</i>	<i>E_HY_WATER_Structure</i>						
<i>Label</i>		24	6.3	1	1		
<i>Level</i>	<i>E_HY_WATER_StructureTx</i>						
<b>DIMENSIONS, 1"=100'</b>							
		24		1	3		
<i>Level</i>	<i>P_RDWY_ROAD_LaneLine</i>						
<b>DIMENSIONS, 1"=200'</b>							
<p><i>NOTE:</i> The size of the text line terminator are double for 1"=200'</p>		24		1	3		
<i>Level</i>	<i>P_RDWY_ROAD_LaneLine</i>						
<b>DIRECTION OF TRAFFIC, CONST.</b>							
					3	<i>Arrow_Str_P</i>	
					3	<i>Arrow_Lt_P</i>	
					3	<i>Arrow_Rt_P</i>	
					3	<i>Arrow_Str_Lt_P</i>	
					3	<i>Arrow_Str_Rt_P</i>	
					3	<i>Arrow_Str_Lt_Rt_P</i>	
<i>Level</i>	<i>P_RDWY_ROAD_Striping</i>						

ITEM	SYMBOL	FT=	TX=	WT=	CO=	LC=	AC=
<b>DIRECTION OF TRAFFIC, EXISTING (Using Cells)</b>							
				1	0	Arrow_Str	
				1	0	Arrow_Lt	
				1	0	Arrow_Rt	
				1	0	Arrow_Str_Lt	
				1	0	Arrow_Str_Rt	
				1	0	Arrow_Str_Lt_Rt	
Level	E_RDWY_ROAD_Striping						
<b>DIRECTION OF TRAFFIC, EXISTING (Using font 84)</b>							
	 Lower case m	84	6.3	1	0		
	 Lower case l	84	6.3	1	0		
	 Lower case n	84	6.3	1	0		
	 Lower case o	84	6.3	1	0		
	 Lower case q	84	6.3	1	0		
	 Lower case p	84	6.3	1	0		
Level	E_RDWY_ROAD_Striping						
<b>DITCH, CONST.</b>							
				5	3	ditch const_V8	
Level	P_HY_STORM_Ditch						
Const. note	Const. ditch 4' flat bottom, 1:2 slopes Dt. exc. - 20 cu. yd.	24	7.5	2	3		
Level	P_RDWY_PL AN_NotesTx						
<b>DITCH, EXISTING</b>							
3' wide or less	 Ditch			1	1	ditch extg_V8	
More than 3' wide	 Ditch			1	1	ditch large_V8	
Level	E_HY_STORM_Ditch						
Label							
Level	E_HY_STORM_DitchTx						

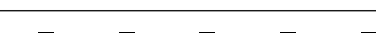
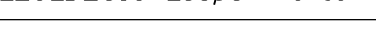
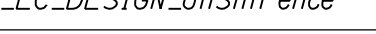
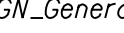

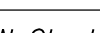



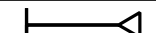

ITEM	SYMBOL	FT=	TX=	WT=	CO=	LC=	AC=
<b>DRIVEWAY, CONST.</b>							
<p><i>NOTE:</i> Station to be closest to centerline with type of material outside of it.</p>							
<i>Levels</i>							
<i>Text</i>	<i>P_RDWY_ROAD_GeneralTx</i>	24	7.5	2	3		
<i>Connection</i>	<i>P_RDWY_ROAD_Approach</i>			1	3		
<i>Driveway</i>	<i>P_RDWY_ROAD_Approach</i>			4	3		
<i>Const. note</i>	<p><i>Const. asph. conc. dwy. type "A-1"</i>  <i>Const. P.C. conc. dwy. type "A", option (A-H)</i>  <i>Const. P.C. conc. commercial dwy., option (A-H)</i>  <i>Const. P.C. conc. dwy., option (A-H)</i>  <i>Const. asph. conc. connection</i></p>						
<i>Level</i>	<i>P_RDWY_PL AN_NotesTx</i>						
<b>DRIVEWAY, EXISTING</b>							
							
<i>Level</i>	<i>E_RDWY_ROAD_Approach</i>						
<i>Label</i>		24	6.3	1	2		
<i>Level</i>	<i>E_RDWY_ROAD_GeneralTx</i>						

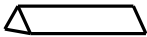
ITEM	SYMBOL	FT=	TX=	WT=	CO=	LC=	AC=
<b>EDGE OF, EXTG.</b>							
<i>Edge of pavement (At aggregate shoulder along side) - Asphalt concrete</i>	----- -----			1	2	3	
<i>Level</i>	<i>E_RDWY_ROAD_EdgeAsph</i>						
<i>Concrete</i>	=====			1	2	0	
<i>Level</i>	<i>E_RDWY_ROAD_EdgeConc</i>						
<i>Gravel</i>	----- -----			1	2	5	
<i>Level</i>	<i>E_RDWY_ROAD_EdgeGravel</i>						
<i>Label</i>		24	6.3	1	2	0	
<i>Level</i>	<i>E_RDWY_ROAD_GeneralTx</i>						
<b>ELECTRICAL UTILITIES, CONST.</b>							
<i>Electric line (Under ground)</i>	----- U E -----			3	3	<i>ug Electric_V8</i>	
<i>Level</i>	<i>P_UTIL_ELEC_UGLine</i>						
<i>Electric line (Above ground)</i>	----- A E -----			3	3	<i>ag Elec_V8</i>	
<i>Level</i>	<i>P_UTIL_ELEC_OHLine</i>						
<i>Electric meter</i>	□			3	3	<i>metpwr</i>	
<i>Using font 84</i>	□ Upper case B	84	6.3	3	3		
<i>Electric transformer (On pad)</i>	□			3	3	<i>riselec</i>	
<i>Using font 84</i>	□ Upper case K	84	6.3	3	3		
<i>Electric vault</i>	□			3	3	<i>Inconbc</i>	
<i>Using font 84</i>	□ Upper case H	84	6.3	3	3		
<i>Level</i>	<i>P_UTIL_ELEC_General</i>						
<i>Const. note</i>	<i>Inst. elec. meter, elec. transformer (By others)</i>	24	7.5	2	3		
<i>Level</i>	<i>P_RDWY_PLAN_NotesTx</i>						



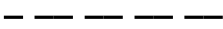
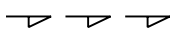

ITEM	SYMBOL	FT=	TX=	WT=	CO=	LC=	AC=
<b>ELECTRICAL UTILITIES, EXTG.</b>							
Electric line (Under ground)	———— U E —————			1	3	ug	Electric_V8
Level	E_UTIL_ELEC_UGLine						
Electric line (Above ground)	———— A E —————			1	3	ag	Elec_V8
Level	E_UTIL_ELEC_OHLine						
Electric manhole	⊙			1	3	mhelec	
Electric junction box	⊞			1	3		
Using font 84	⊞ Lower case e	84	6.3	1	3		
Electric meter	⊞			1	3	metpwr	
Using font 84	⊞ Upper case B	84	6.3	3	3		
Electric transformer (On pad)	⊞			1	3	riselec	
Using font 84	⊞ Upper case K	84	6.3	3	3		
Electric vault	⊞			1	3	inextg	
Using font 84	⊞ Upper case H	84	6.3	3	3		
Level	E_UTIL_ELEC_General						
Label	Electric meter, electric transformer	24	6.3	1	3		
Level	E_UTIL_ELEC_GeneralTx						
<b>EQUATION, ON PROFILE</b>							
Calculations for checking station equations				Subtract ahead station from 100. add back station			
<p> <math>40+12.00, Bk.=</math>      <math>12.00</math>  <math>40+38.00, Ah.</math>      <math>100.00</math>  <math>12.00</math>  <math>+62.00</math>  <math>74.00</math>  <math>74.00'</math>  <math>lc=pro subgrade_V8; wt=5</math>  <math>tx=9.4; ft=24; wt=4</math>  <math>tx=7.5; ft=24; wt=2</math> </p>							
Level	P_RDWY_PROF_Subgrade						

ITEM	SYMBOL	FT=	TX=	WT=	CO=	LC=	AC=
<b>EROSION CONTROL</b>							
Straw bale sediment barrier				4	3	straw bale	sed bar_v8
Level	P_EC_DESIGN_StrawBale						
Straw wattle barrier				4	3	straw wattle	barrier_v8
Level	P_EC_DESIGN_StrawWattle						
Supported sediment fence				4	3	sup sed	fence_v8
Level	P_EC_DESIGN_SupSiltFence						
Unsupported sediment fence				4	3	unsup sed	fence_v8
Level	P_EC_DESIGN_UnSiltFence						
Orange plastic fence				4	3	orange plastic	fence_v8
Level	P_EC_DESIGN_General						
BioBag				1	3	DET_BIOBAG	
Level	P_EC_DESIGN_BioBags						
Check dam				4	3	DET_CKDM	
Level	P_EC_DESIGN_Check Dam						
Inflow check dam				4	3	DET_CKDMFLOW	
Level	P_EC_DESIGN_Check Dam						
Construction entrance				1	0	DET_CONSTENT	
Level	P_EC_DESIGN_AggConstEnt						
Inlet protection				4	3	DET_INLETP	
Level	P_EC_DESIGN_InletProtection						
Scour basin				4	3	DET_SCRBSN	
Level	P_EC_DESIGN_ScourBasin						
Sediment trap				4	3	DET_SEDTRAP	
Level	P_EC_DESIGN_SedTrap						
Temp slope drain				4	3	DET_SLOPDR	
Level	P_EC_DESIGN_TempSlopeDr						
Brush barrier				4	3	brush line_v8	
Level	P_EC_DESIGN_General						

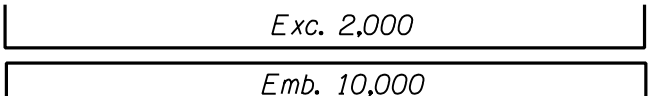
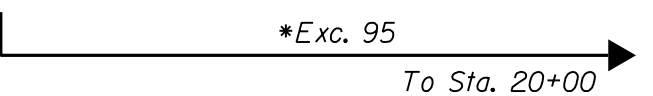
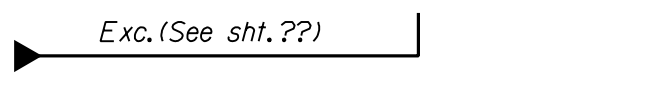
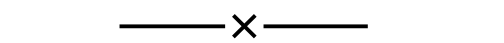
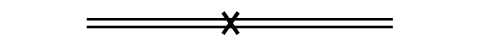





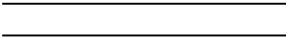
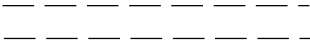

ITEM	SYMBOL	FT=	TX=	WT=	CO=	LC=	AC=
<b>EROSION CONTROL CONT.</b>							
<i>Sediment mat</i>				4	3	DET_SEDMAT	
Level	<i>P_EC_DESIGN_General</i>						
<i>Sediment barrier</i>				4	3	DET_PREFAB	
Level	<i>P_EC_DESIGN_SedBarrier</i>						
<i>Erosion control matting</i>				2	3	PAT_ECMAT	
Level	<i>P_EC_DESIGN_Matting</i>						
<i>Stake turb barrier</i>				4	3	stk'd turb bar_V8	
Level	<i>P_EC_DESIGN_StakeTurbBarrier</i>						
<i>Floating turb barrier</i>				4	3	flt'g turb bar_V8	
Level	<i>P_EC_DESIGN_TurbBarrier</i>						
<i>Seeding &amp; mulching</i>				2	3	PAT_SEEDMUL	
Level	<i>P_EC_DESIGN_SeedMulching</i>						
<i>Compost blanket</i>				2	3	PAT_COMPB	
Level	<i>P_EC_DESIGN_CompostBlanket</i>						
<i>Compost filter berm</i>				4	3	compost filter berm_V8	
Level	<i>P_EC_DESIGN_Compost</i>						
<i>Compost sock</i>				4	3	compost sock sed' bar_V8	
Level	<i>P_EC_DESIGN_Compost</i>						
<i>Filter berm</i>				2	3	berm_V8	
Level	<i>P_EC_DESIGN_Compost</i>						
<i>Temporary drainage curb</i>				4	3	approach const_V8	
Level	<i>P_EC_DESIGN_TempSlopeDr</i>						
<i>Diversion dike</i>				2	3	diversion dike_V8	
Level	<i>P_EC_DESIGN_DiversionDike</i>						
<i>Diversion swale</i>				2	3	diversion swale_V8	
Level	<i>P_EC_DESIGN_DiversionSwale</i>						
<i>Diversion dike/swale</i>				2	3	diversion dike-swale_V8	
Level	<i>P_EC_DESIGN_DiversionDike</i>						



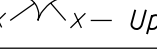

ITEM	SYMBOL	FT=	TX=	WT=	CO=	LC=	AC=
<b>EXCAVATION &amp; EMBANKMENT</b>							
<i>Brackets on a single sheet</i>		24	7.5	5	3	0	
<i>Bracket contd. on 2nd sheet (1st sheet)</i>		24	7.5	5	3	0	
<i>Bracket contd. on 2nd sheet (2nd sheet)</i>							
* Place quantity at the center of the first sheet							
<i>Level</i>	<i>P_RDWY_PROF_GeneralTx</i>						
<b>FENCE, CONST.</b>							
				5	3		<i>fenceC_V8</i>
<i>Level</i>	<i>P_RDWY_ROAD_Fence</i>						
<i>Const. note</i>	<i>Const. type 2 fence</i>						
<i>Level</i>	<i>P_RDWY_PLAN_NotesTx</i>						
<b>FENCE ON BARRIER</b>							
				5	3		<i>barrier median_V8</i>
<i>Place X on top of barrier using ft=4, tx=7.5, wt=5, 65' apart</i>							
<i>Level</i>	<i>P_RDWY_ROAD_Fence</i>						
<i>Const. note</i>	<i>Const. type 2 fence on barrier</i>						
<i>Level</i>	<i>P_RDWY_PLAN_NotesTx</i>						

ITEM	SYMBOL	FT=	TX=	WT=	CO=	LC=	AC=
<b>FENCE, EXISTING</b>							
				1	2	fence CE_V8	
Level	E_RDWY_ROAD_Fence						
Label	6' ch. link	24	6.3	1	2		
Level	E_RDWY_ROAD_FenceTx						
<b>FIRE HYDRANT, CONST.</b>							
				3	1	fire	
Level	P_UTIL_WTR_General						
Const. note	Inst. fire hydrant (By others)	24	7.5	2	3		
Level	P_RDWY_PL AN_NotesTx						
<b>FIRE HYDRANT, EXISTING</b>							
				1	1	fire	
Using font 84		84	6.3	3	3		
Level	E_UTIL_WTR_General						
<b>FIRE ALARM SYSTEM, EXISTING</b>							
		24	6.3	1	1	jbwtr	
Level	E_UTIL_WTR_General						
<b>FRONTAGE ROAD, CONST.</b>							
				2	3	0	
Level	P_RDWY_ROAD_Approach						
Const. note	Const. frontage road	24	7.5	2	3		
Level	P_RDWY_PL AN_NotesTx						
<b>FRONTAGE ROAD, EXTG.</b>							
				1	2	3	
Level	E_RDWY_ROAD_Approach						
Label	CAPITOL ST.	2	9.4	2	2		
Level	E_RDWY_ROAD_NameTx						

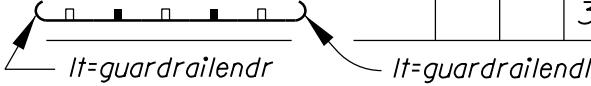
ITEM	SYMBOL	FT=	TX=	WT=	CO=	LC=	AC=
<b>GAS FILLER CAP</b>							
	G.F. ○ R. = 4"			1	4		
Level	P_UTIL_GAS_General						
Label		24	6.3	1	4		
Level	P_UTIL_GAS_GeneralTx						
<b>GAS UTILITIES, CONST.</b>							
Line	————— G —————	24	1.0	3	4	ug Gas_V8	
Level	P_UTIL_GAS_Pipe						
Label	24" gas	24	6.3	2	4		
Level	P_UTIL_GAS_GeneralTx						
Meter	G.M. □			3	4	metgas	
Using font 84	□ Upper case B	84	6.3	3	4		
Valve	G.V. ⊙			3	4	valgas	
Using font 84	⊙ Upper case E	84	6.3	3	4		
Vent pipe	R. = 4" ○ G.vent			3	4		
Level	P_UTIL_GAS_General						
<b>GAS UTILITIES, EXISTING</b>							
Line	————— G —————	24	1.0	1	4	ug Gas_V8	
Level	E_UTIL_GAS_Pipe						
Label	24" gas	24	6.3	1	4		
Level	E_UTIL_GAS_GeneralTx						
Gas junction box	□		6.3	1	4	jbgas	
Using font 84	□ Lower case e	84	6.3	1	4		
Meter	G.M. □			1	4	metgas	
Using font 84	□ Upper case B	84	6.3	1	4		
Valve	G.V. ⊙			1	4	valgas	
Using font 84	⊙ Upper case E	84	6.3	1	4		
Vent pipe	R. = 4" ○ G.vent			1	4		
Level	E_UTIL_GAS_General						

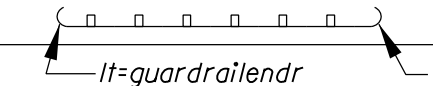
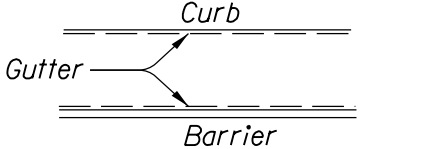





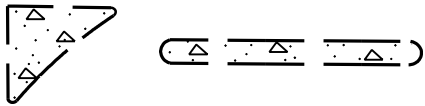

ITEM	SYMBOL	FT=	TX=	WT=	CO=	LC=	AC=
<b>GATE, CONST.</b>							
				5	3	gate_V8	
Level	P_RDWY_ROAD_Fence						
Const. note	Inst. 15' gate	24	7.5	2	3		
Const. note	Inst. 15' gateway	24	7.5	2	3		
Level	P_RDWY_PL AN_NotesTx						
<b>GATE, EXISTING</b>							
				1	2	gate_V8	
Using font 84	-x  - Upper case ^	84	9.4	1	2		
Level	E_RDWY_ROAD_Fence						
Label	15'	24	6.3	1	2		
Level	E_RDWY_ROAD_FenceTx						
<b>GATE (LOCKED), CONST.</b>							
				5	3	gate locked_V8	
Level	P_RDWY_ROAD_Fence						
Const. note	Inst. 15' locked gate	24	7.5	2	3		
Level	P_RDWY_PL AN_NotesTx						
<b>GATE (LOCKED), EXISTING</b>							
				1	2	gate locked_V8	
Using font 84	-x  - Upper case &	84	9.4	1	2		
Level	E_RDWY_ROAD_Fence						
Label	15'	24	6.3	1	2		
Level	E_RDWY_ROAD_FenceTx						
<b>GROUND WATER, EXTG.</b>							
				3	7	M_GroundWater	
Level	P_BR_SUB_General						

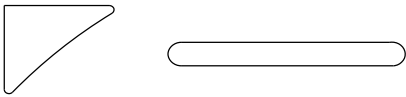
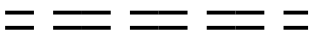
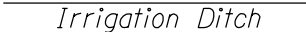





ITEM	SYMBOL	FT=	TX=	WT=	CO=	LC=	AC=
<b>GUARDRAIL, CONST.</b>							
				3	3	gr	const_V8
Level	P_RDWY_ROAD_Guardrail						
<b>GUARDRAIL, ADJUST EXTG.</b>							
				3	3	gr	C E_V8
Level	P_RDWY_ROAD_Guardrail						
Const. note	(See below)	24	7.5	2	3		
Level	P_RDWY_PLAN_NotesTx						
(For sheets where guardrail is shown on one sheet)	<p>Sta. 10+00 to Sta. "GR" 20+56.62  Remove extg. guardrail - 857.25'  Adjust guardrail - 199.37'  Const. guardrail - 1,056.62' (Type 2A)  - 12.5' (Type 3)  Extra for 8' guardrail posts - 555  Const. guardrail transition  Flare rate=0, W=0, E=2'  Const. anchor - 2 (Type 1 mod.)  Inst. end piece - 2 (Type C)  Const. guardrail terminal, flared - 2  Const. mound terminal</p>						
(For sheets where guardrail is shown on two sheets or last sheet)	<p>See sheet X, note Y  Const. guardrail  Flare rate=0, W=0, E=2'  Const. guardrail terminal, flared</p>						
<p><b>NOTE:</b>  In note only show what is on the sheet</p>							
<ol style="list-style-type: none"> <li>1. Guardrail note normally to be on first sheet.</li> <li>2. Median &amp; shldr. barrier note to be treated the same as guardrail note.</li> <li>3. List guardrail types numerically (2A, 3, transition)</li> </ol>							

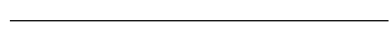

ITEM	SYMBOL	FT=	TX=	WT=	CO=	LC=	AC=
<b>GUARDRAIL, EXISTING</b>							
				1	2	gr extg_v8	
Level	<i>E_RDWY_ROAD_Guardrail</i>						
Label		24	6.3	1	2		
Level	<i>E_RDWY_ROAD_GeneralTx</i>						
<b>GUTTER</b>							
<p><i>Not E.P., but a break line that should NOT be shown on the base map</i></p>				1	2	3	
Level	<i>E_TERR_DTM_BrkLines</i>						
<b>HANDRAIL, CONST.</b>							
				3	3	handrail construct_v8	
Level	<i>P_RDWY_ROAD_Handrail</i>						
Const. note	<i>Const. handrail</i>	24	7.5	2	3		
Level	<i>P_RDWY_PL AN_NotesTx</i>						
<b>HANDRAIL, EXISTING</b>							
				1	2	handrail existing_v8	
Level	<i>E_RDWY_ROAD_Handrail</i>						
Label		24	6.3	1	2		
Level	<i>E_RDWY_ROAD_GeneralTx</i>						
<b>HEAT PUMP</b>							
				1	3	maile	
Using font 84		84	6.3	1	3		
Level	<i>E_UTIL_ELEC_General</i>						
Label	<i>Heat pump</i>	24	6.3	1	3		
Level	<i>E_UTIL_ELEC_GeneralTx</i>						

ITEM	SYMBOL	FT=	TX=	WT=	CO=	LC=	AC=
<b>INLET CONST.</b>							
<i>Construct</i>	■			1	3	<i>Inconbc</i>	
<i>Reconstruct</i>	◼			1	3	<i>Inrecbc</i>	
<i>Remove</i>	⊗			1	3	<i>Inrembc</i>	
<i>Adjust</i>	◼			1	3	<i>Inadjbc</i>	
<i>Cap</i>	□			3	3	<i>Incapbc</i>	
<i>Level</i>	<i>P_HY_STORM_Inlet</i>						
<i>Const. note</i>	<i>Const. type "CG-1" inlet</i>	24	7.5	2	3		
<i>Level</i>	<i>P_RDWY_PLAN_NotesTx</i>						
<b>INLET, EXISTING</b>							
	<i>"G-2" inlet</i> □			1	1	<i>inextc</i>	
<i>Using font 84</i>	□ <i>Upper case K</i>	84	6.3	1	1		
<i>Level</i>	<i>E_HY_STORM_Inlet</i>						
<i>Label</i>	<i>"G-2" inlet</i>	24	6.3	1	1		
<i>Level</i>	<i>E_HY_STORM_InletTx</i>						
<i>Descriptive text</i>	<i>Grate size</i> <i>Top 52.35 m</i> <i>100 S.F.L. 51.85</i> <i>300 S.F.L. 51.65</i> <i>N.F.L. 51.63</i>	24	6.3	1	1		
<i>Level</i>	<i>E_HY_STORM_DescriptiveTx</i>						
<b>ISLAND &amp; TRAFFIC SEPARATOR, CONST.</b>							
				3	3	0	
<i>Level</i>	<i>P_RDWY_ROAD_Curb</i>						
<i>Const. note</i>	<i>Const. type "C" conc. island (Mountable)</i> <i>Const. type "B" traffic separator</i>	24	7.5	2	3		
<i>Level</i>	<i>P_RDWY_PLAN_NotesTx</i>						

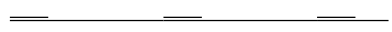

ITEM	SYMBOL	FT=	TX=	WT=	CO=	LC=	AC=
<b>ISLAND &amp; TRAFFIC SEPARATOR, EXISTING</b>							
				1	2		0
Level	E_RDWY_ROAD_Curb						
<b>IRRIGATION DITCH, CONST.</b>							
				5	1		ditch const_V8
Level	P_HY_STORM_Ditch						
Const. note	Const. irrigation ditch 4' flat bottom, 1:2 slopes Dt. exc. - 20 cu. yd.	24	7.5	2	3		
Level	P_RDWY_PLAN_NotesTx						
<b>IRRIGATION DITCH, EXTG.</b>							
				1	2		0
Level	E_HY_STORM_Ditch						
Label		24	7.5	1	2		
Level	E_HY_STORM_DitchTx						
<b>JUNCTION BOX, EXTG.</b>							
				1	*		jbgas
				1	*		jbelec
				1	*		jbsan
				1	*		jbcomm
				1	*		jbwtr
				1	*		Liscad S62
Using font 84		84	7.5	1	*		
Level	(See like utility)						
Label	Type of junction box (Except signal)	24	6.3	1	*		
Level	(See like utility)						
* Use same color as the utility (See the utilities for the colors)							

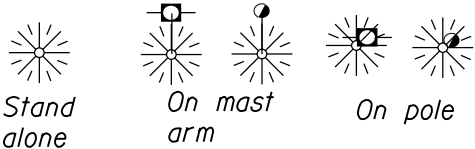

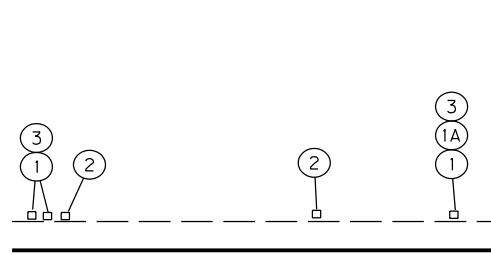
ITEM	SYMBOL	FT=	TX=	WT=	CO=	LC=	AC=
<b>LAKE</b>							
				1	1	0	
Level	E_HY_WATER_Edge						
Label	DIAMOND LAKE	24	7.5	2	1		
Level	E_HY_WATER_GeneralTx						
<b>LAMPHOLE</b>							
				1	2		lamphl
Level	E_UTIL_MISC_General						
<b>LANE LINE, CONST.</b>							
				1	3	0	
Level	P_RDWY_ROAD_Laneline						
Lane line text	12'	24	6.3	1	3		
	P_RDWY_ROAD_GeneralTx						
<b>LANE LINE, EXISTING (Striping)</b>							
Fog				1	0		stripe solid_v8
Skip				1	0		stripe skip_v8
No pass				1	4		stripe skip/nopass_v8
Double solid				1	4		stripe solid double_v8
Double solid narrow				1	4		stripe solid double/nar_v8
Level	E_RDWY_ROAD_Striping						
<b>LIMITS OF PROJECT</b>							
<b>BEGINNING OF PROJECT</b> XX-XX-(X)XXX ← Fed. Aid No., if federally funded STA. XX+XX (MP. XX.XXX) →		24	11	5			
				5	3		pro subgrade_v8
Level	P_RDWY_PL AN_NotesTx						
<b>LIMITS OF GRADING PROJECT</b>							
<b>GRADING ONLY</b> →		24	11	5			
				3	3		pro subgrade_v8
Level	P_RDWY_PL AN_NotesTx						







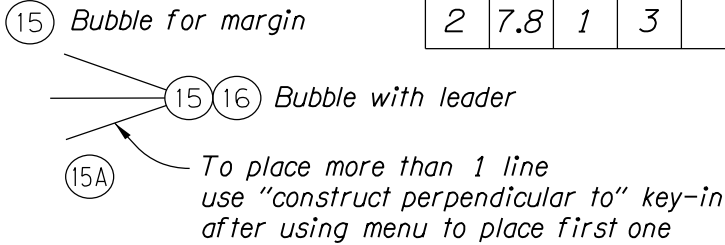
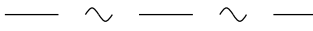
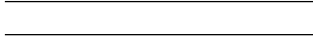
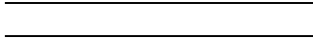
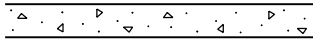
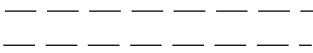
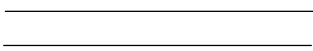
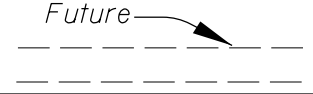





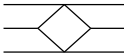

ITEM	SYMBOL	FT=	TX=	WT=	CO=	LC=	AC=
<b>LINE LABELS</b>							
	"A" LINE	2	12.5	3			
	(For profile, see sht.??)	24	7.5	2			
Level	P_RDWY_PLAN_NotesTx						
<b>LUMINAIRE, EXISTING</b>							
Mast arm WT=1, CO=2	 <p>Stand alone      On mast arm      On pole</p>			1	3	Lumin	*Place poles on their own level
Using font 84	 Upper case C	84	7.5	1	3		
Level	E_TRAF_ILLUM_Poles						
<b>MAILBOX, CONST.</b>							
	□			1	3	Mailbox C	
Using font 84	□ Upper case K	84	6.3	1	3		
Level							
Const. note	(See below)	24	7.5	2	3		
Level							
<b>MAILBOX INSTALLATION</b> (When locations are known)							
	<p>① Inst. single mailbox support - 3          ①A Const. conc. collar          (See drg. no. RD100)</p> <p>② Inst. multiple mailbox support - 2          Const. conc. collar - 2</p> <p>③ Const. mailbox service turnout - 3</p>						
These notes may be combined if all information is the same							
<b>MAILBOX INSTALLATION</b> *(When locations are not known)							
	<p>① Inst. single mailbox support - 8          Inst. multiple mailbox support - 6          Const. mailbox service turnout - 8          (See drg. no. RD100)          (Location as directed)</p>						
*Note to be placed on sheet 3 of plans							

ITEM	SYMBOL	FT=	TX=	WT=	CO=	LC=	AC=
<b>MAILBOX (PAPER BOX), EXTG.</b>							
	□			1	2	<i>maile</i>	
<i>Using font 84</i>	□ <i>Upper case K</i>	84	6.3	1	3		
<i>Level</i>	<i>E_RDWY_ROAD_Mailbox</i>						
<i>Label</i>	<i>Mailing address Who it is/company paperbox</i>	24	6.3	1	2		
<i>Level</i>	<i>E_RDWY_ROAD_MailboxTx</i>						
<b>MANHOLE, CONST.</b>							
<i>Construct</i>	●			1	3	<i>MHconst</i>	
<i>Construct manlet</i>	■			1	3	<i>MHinlet</i>	
<i>Reconstruct</i>	◐			1	3	<i>MHreconst</i>	
<i>Remove</i>	⊕			1	3	<i>MHremove</i>	
<i>Adjust</i>	⊗			1	3	<i>MHadjust</i>	
<i>Cap</i>	○			3	3	<i>MHcapped</i>	
<i>Level</i>	<i>P_HY_STORM_MH</i>						
<i>Const. note</i>	<i>Const. manhole</i>	24	7.5	2	3		
<i>Level</i>	<i>P_RDWY_PLAN_NotesTx</i>						
<b>MANHOLE, EXISTING</b>							
<i>Storm</i>	⊙			1	1	<i>mhst</i>	
<i>Using font 84</i>	⊙ <i>Upper case G</i>	84	6.3	1	3		
<i>Level</i>	<i>E_HY_STORM_MH</i>						
<i>Label</i>	<i>M.H.</i>	24	6.3	1	1		
<i>Level</i>	<i>E_HY_STORM_MHTx</i>						
<i>Descriptive text For example, see sht. AP4</i>	<i>M.H. Top 52.85' 12" N.F.L. 56.36' 18" N.F.L. 51.00' S.F.L. 51.05'</i>	24	6.3	1	1		
<i>Level</i>	<i>E_HY_STORM_DescriptiveTx</i>						













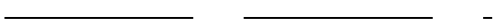

ITEM	SYMBOL	FT=	TX=	WT=	CO=	LC=	AC=
<b>MANHOLE, EXISTING (CONT'D)</b>							
<i>Sanitary</i>	⊙			1	2	<i>mhesan</i>	
<i>Using font 84</i>	⊙ <i>Upper case G</i>	84	6.3	1	2		
<i>Level</i>	<i>E_UTIL_SAN_General</i>						
<i>Label</i>	<i>San. M.H.</i>	24	6.3	1	2		
<i>Level</i>	<i>E_UTIL_SAN_GeneralTx</i>						
<i>Descriptive text</i> <i>For example, see sht. AP4</i>	<i>San. M.H.</i> <i>Top 32.64 m</i> <i>N. F. L. 52.36</i>	24	6.3	1	2		
<i>Level</i>	<i>E_UTIL_SAN_FlowTx</i>						
<i>Telephone</i>	⊙			1	6	<i>mhecomm</i>	
<i>Using font 84</i>	⊙ <i>Lower Case b</i>	84	6.3	1	6		
<i>Level</i>	<i>E_UTIL_COMM_General</i>						
<i>Label</i>	<i>Tel. M.H.</i>	24	6.3	1	6		
<i>Level</i>	<i>E_UTIL_COMM_GeneralTx</i>						
<b>MATCH LINE</b>							
SEE SHEET 6A <b><u>MATCH LINE</u></b> -		2	6.3	1	3		
		2	9.4	3	3		
				5	3	<i>pro subgrade_V8</i>	
<i>Level</i>	<i>P_RDWY_PLAN_NotesTx</i>						
<b>MISCELLANEOUS, EXTG.</b>							
<i>Whatever's not listed</i>							
<i>Label</i>	<i>What it is</i>	24	6.3	1	*		
<i>* Use same color as symbol</i>							

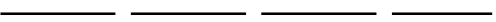
ITEM	SYMBOL	FT=	TX=	WT=	CO=	LC=	AC=															
<b>NAMES, EXISTING</b>																						
<i>Hwy.</i>	COLUMBIA RIVER HWY.	2	9.4	2	2																	
<i>Roads &amp; streets</i>	CAPITOL ST. E.	2	9.4	2	2																	
<i>City</i>	REMOTE	2	7.8	2	2																	
<i>Level</i>	<i>E_RDWY_ROAD_NameTx</i>																					
<i>River, lake, canal</i>	SILETZ RIVER	24	7.5	2	1																	
<i>Little creek, spring</i>	Mouse Creek	24	6.3	1	1																	
<i>Large creek, stream</i>	ELEPHANT CREEK	24	6.3	1	1																	
<i>Level</i>	<i>E_HY_WATER_GeneralTx</i>																					
<b>NO WORK AREA</b>																						
<table border="1" data-bbox="1084 898 1531 1066"> <tr> <td></td> <td></td> <td>5</td> <td>3</td> <td><i>pro subgrade_v8</i></td> </tr> <tr> <td>24</td> <td>9.4</td> <td>4</td> <td>3</td> <td></td> </tr> <tr> <td></td> <td></td> <td>2</td> <td>3</td> <td>0</td> </tr> </table>										5	3	<i>pro subgrade_v8</i>	24	9.4	4	3				2	3	0
		5	3	<i>pro subgrade_v8</i>																		
24	9.4	4	3																			
		2	3	0																		
<i>Level</i>	<i>P_RDWY_PLAN_NotesTx</i>																					
<b>NO WORK AREA BOUNDARY</b>																						
<i>Level</i>	<i>P_AGG_DESIGN_NoWorkArea</i>			2	4		3															
<b>NORTH ARROW</b>																						
<p><b>NORTH ARROW, 1"=100'</b> <i>Scale=1.0</i></p> <p><b>NORTH ARROW, 1"=200'</b> <i>Scale=2.0</i></p>							<i>arrow</i>															
<i>Level</i>	<i>P_ODOT_PLAN_General</i>																					

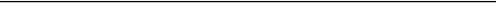
ITEM	SYMBOL	FT=	TX=	WT=	CO=	LC=	AC=					
<b>NOTE BUBBLE</b>												
<p>These items are found in ODOT menu under FD Plans - Notes</p> <p>Menu will place 3 digit on its own</p>		2	7.8	1	3							
Level	P_RDWY_PLAN_NotesTx											
<b>NOTES, ORDER OF</b>												
	See sht. AP1						24	7.5	2	3		
<b>ORDINARY HIGH WATER</b>												
Level									1	1	ohw_V8	
Level	E_HY_STORM_OHWLline											
<b>PAVEMENT, CONST.</b>												
Level	<p>Asph. </p>			1	3	0						
Level	P_RDWY_ROAD_EdgeAsph											
Level	<p>Conc. </p>			2	3	0						
Level	P_RDWY_ROAD_EdgeConc											
Level	<p>Conc. patterning ap=PAT_conc </p>			1	2							
<b>PAVEMENT, EXISTING</b>												
Level				1	2	3						
Level	E_RDWY_ROAD_EdgeAsph											
Level				1	2	0						
Level	E_RDWY_ROAD_EdgeConc											
Label							24	6.3	1	2		
Level	E_RDWY_ROAD_GeneralTx											
<b>PAVEMENT (FUTURE)</b>												
Text	<p>Future </p>	24	6.3	1	3							
Level				0	3	3						
Level	E_RDWY_ROAD_EdgeAsph											
<b>PIPE (SEE CULVERT OR SEWER)</b>												
<b>PIPE DATA</b>												
	See sht. AP2											

ITEM	SYMBOL	FT=	TX=	WT=	CO=	LC=	AC=
<b>POLES, CONST.</b>							
Power				3	3	PoleElec	
Level	P_UTIL_ELEC_Pole						
Const. note	Inst. power pole (By others)	24	7.5	2	3		
Level	P_RDWY_PLAN_NotesTx						
<b>POLES, EXTG.</b>							
Power				1	3	polp	
Using font 84	 Upper case A	84	6.3	1	3		
Joint use				1	3	polj	
Using font 84	 Upper case \$	84	6.3	1	3		
Guy & anchor	 lc=2, wt=0			1	3	anchpwr	
BPA				1	6	polbpa	
Level	E_UTIL_ELEC_Pole						
Label power	PGE #123	24	6.3	1	3		
Label joint use	PGE #123 Telephone CATV CATV box Transformer E. meter Undrgrd. pow.	24	6.3	1	*		
NOTE:	List everything on the pole for the utility people	* Labels to be in the same color as the utility					
Level	E_UTIL_ELEC_PoleTx						
Telephone				1	6	polt	
Using font 84	 Upper case I	84	6.3	1	6		
Level	E_UTIL_COMM_Pole						
Label telephone	No #	24	6.3	1	6		
Level	E_UTIL_COMM_PoleTx						
Wood				1	2	polw	
Using font 84	 Lower case d	84	6.3	1	2		
Steel				1	0	pols	
Using font 84	 Lower case s	84	6.3	1	0		
Level	E_UTIL_MISC_General						
<b>POND, CONST.</b>							
	 Level=P_HY_STORM_Water			2	1	pond_const_v8	
Label	Level=P_HY_STORM_WaterTx	24	5.3	2	1		
<b>POND, EXTG.</b>							
	 Level=E_HY_STORM_Water			1	1	pond_extg_v8	
Label	Level=E_HY_STORM_WaterTx	24	5.3	1	1		

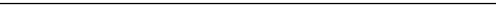







ITEM	SYMBOL	FT=	TX=	WT=	CO=	LC=	AC=
<b>PROFILES</b> (For profile sheet information, see shts. AP7 & AP8)							
Ground Line				2	2	0	
Level	E_RDWY_PROF_Ground						
Profile grade				5	3	0	
Level	P_RDWY_PROF_Align						
Orig. ground				2	1	pro orig grnd_V8	
Level	E_RDWY_PROF_Ground						
Subgrade				5	3	pro subgrade_V8	
Level	P_RDWY_PROF_Subgrade						
Main line	N. Bound 			3	3	0	
	S. Bound 			3	5	pro line 3_V8	
Level	P_RDWY_PROF_Align						
3 or more lines				3	4	pro line 2_V8	
				3	3	0	
				3	5	pro line 3_V8	
Level	P_RDWY_PROF_Align						
Channel change				5	3	0	
Level	P_RDWY_PROF_Align						
Sel. subgrade matl.				5	3	pro sel subgrade_V8	
Level	P_RDWY_PROF_Subgrade						
Sewer				3	3	pipe const_V8	
Extg. sewer				2	6	Pro drain pipe_V8	
Drain pipe				3	3	pro drain pipe_V8	
Level	P_RDWY_PROF_Storm						



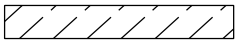
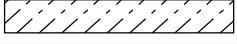
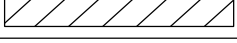
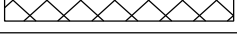

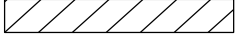

**PROJECT NUMBER** (See sht. 32, Limits of Project)



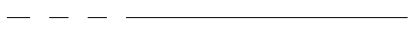
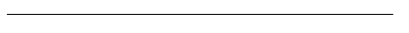
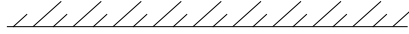

- ① The Project Number, also known as the Federal Aid Number, is placed in the following locations:
  - The title sheet (sheet 1)
  - At Beginning and End of Project on both plan and profile of roadway plan sheets.
  - At Beginning and End of Project on striping plan sheets.
- ② See sht. AP13 for usage on the title sheet.
- ③ See sht. 32 in this guide and Vol. 2 chapter 4 for examples of placement on roadway plan sheets.
- ④ See Striping Plan Guide for examples of placement on striping plan sheets.

ITEM	SYMBOL	FT=	TX=	WT=	CO=	LC=	AC=
<b>RAILROAD, CONST.</b>							
				5	3		<i>rrtrack_V8</i>
<i>Future</i>				3	2		<i>rrtrack future_V8</i>
<i>Shoofly</i>				3	3		<i>rrtrack_V8</i>
<i>Level</i>	<i>P_RDWY_RR_Track</i>						
<i>Const. note</i>	<i>Const. shoofly (By others)</i>	24	7.5	2	3		
<i>Level</i>	<i>P_RDWY_PLAN_NotesTx</i>						
<b>RAILROAD, EXISTING</b>							
		24	6.3	1	2		<i>rrtrack_V8</i>
<i>Level</i>	<i>E_RDWY_RR_Track</i>						
<i>Label</i>	<i>Union Pacific</i>	24	7.5	2	2		
<i>Level</i>	<i>E_RDWY_RR_GeneralTx</i>						
<i>Ballast</i>				1	2	5	
<i>Level</i>	<i>E_RDWY_RR_Ballast</i>						
<i>RR signal</i>				1	2		<i>rrsig</i>
<i>Level</i>	<i>E_RDWY_RR_Signal</i>						
<i>Label</i>		24	6.3	1	2		
<i>Level</i>	<i>E_RDWY_RR_SignalTx</i>						
<b>RAMP METER, POLE</b>							
				1	5		<i>polsig</i>
<i>Using font 84</i>		84	6.3	1	5		<i>Lower case s</i>
<i>Level</i>	<i>E_RDWY_ROAD_Pole</i>						
<b>RAMP METER, SIGNS</b>							
<i>Using font 84</i>		84	6.3	1	5		<i>Upper case W</i>
<i>Using font 84</i>		84	6.3	1	5		<i>Lower case y</i>
<i>Level</i>	<i>E_TRAF_SIGN_PublicSign</i>						
<i>Label</i>		24	6.3	1	5		
<i>Level</i>	<i>E_TRAF_SIGN_SigningTx</i>						





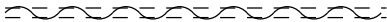
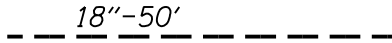

ITEM	SYMBOL	FT=	TX=	WT=	CO=	LC=	AC=
<b>RANDOM FILL</b>							
				5	3	Random fill_V8	
Level	P_RDWY_ROAD_Slope						
Const. note	Const.random fill - 20 cu.yd.	24	7.5	2	3		
Level	P_RDWY_PLAN_NotesTx						
<b>REMOVAL, CONST.</b>							
Building				5	3	0	
Cold plane				1	3	3	
Hazardous matl. site				1	0	4	
Old roadway				1	3	0	
Sidewalk				1	3	0	
Curb	Shown on removal plan sheet only				4	3	curb const_V8
Level	P_RDWY_PLAN_Removal						
<b>RETAINING WALL, CONST.</b>							
				3	3	barrier median_V8	
Level	P_GT_WALL_Retaining						
Const. note	Const.retaining wall	24	7.5	2	3		
Level	P_RDWY_PLAN_NotesTx						
<b>RESTRICTED WORK AREA</b>							
				1	3	0	
Note	Contractor may not occupy area shown thus, prior to Jan. 3, 2007		24	7.5	2	3	
Level	P_RDWY_PLAN_NotesTx						
<b>RETAINING WALL, EXISTING</b>							
				1	0		
Level	E_GT_WALL_Retaining						
Label	Type of wall & size	24	6.3	1	0		
Level	E_GT_WALL_GeneralTx						
<p>NOTE:  Survey will show a single line for extg. retaining wall and note which side the shot was taken and the width  The Drafter will copy parallel for the width.</p>							

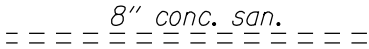
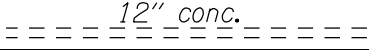
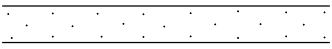
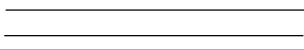
ITEM	SYMBOL	FT=	TX=	WT=	CO=	LC=	AC=
<b>REVISION NOTE</b>							
	Revised 11-14-2003, added guardrail - 25'	2	6.3	2	3	Rev_Triangle	
Level	P_RDWY_PL AN_NotesTx						
<b>RIGHT OF WAY, PROPOSED</b>							
Access control	_____ - _____			3	5	access_V8	
Level	P_RW_FEE_Access						
Text		24	5.0	2	5		
Level	P_RW_FEE_AccessTx						
Perm. Easement	-----			1	5	2	
Level	P_RW_EASE_Perm						
Text		24	5.0	0	5		
Level	P_RW_EASE_PermTx						
Temp. Easement	-----			1	5	2	
Level	P_RW_EASE_Temp						
Text		24	5.0	0	5		
Level	P_RW_EASE_TempTx						
Normal take	_____			2	5	0	
Level	P_RW_FEE_Normal						
Labels		24	5.0	2	5		
Level	P_RW_FEE_NormalTx						
<b>RIGHT OF WAY, EXISTING</b>							
Access Control	_____ - _____			1	4	access_V8	
Level	E_SURV_BNDRY_AccessControl						
Labels		24	7.5	2	4		
Level	E_SURV_BNDRY_AccessControlTx						
Easement	-----			1	4	2	
Level	E_SURV_BNDRY_Easement						
Labels		24	5.0	2	4		
Level	E_SURV_BNDRY_EasementTx						
Property line	_____			0	4	0	
Level	E_SURV_BNDRY_Property						





ITEM	SYMBOL	FT=	TX=	WT=	CO=	LC=	AC=
<b>RIGHT OF WAY, EXISTING (CONT.)</b>							
Labels		24	6.0	2	4		
Level	<i>E_SURV_BNDRY_OwnerTx</i>						
Railroad right of way				0	4		<i>rrr/w_V8</i>
Level	<i>E_SURV_BNDRY_RRROW</i>						
Labels		24	7.5	2	4		
Level	<i>E_SURV_BNDRY_RRROWTx</i>						
Right of way				0	4		0
Level	<i>E_SURV_BNDRY_ROW</i>						
Labels		24	7.5	2	4		
Level	<i>E_SURV_BNDRY_ROW</i>						
Restricted right of way				0	4		0
Level	<i>E_SURV_BNDRY_RW</i>						
Labels		24	7.5	2	4		
Level	<i>P_RDWY_PLAN_NotesTx</i>						
<b>RIVER</b>							
				1	1		0
Level	<i>E_HY_WATER_Edge</i>						
Label	<i>UMPQUA RIVER</i>	24	7.5	2	1		
Level	<i>E_HY_WATER_GeneralTx</i>						
<b>RIPRAP, CONST.</b>							
				1	0		<i>riprap3</i>
				1	0		<i>riprap2</i>
				1	0		<i>riprap1</i>
Level	<i>P_HY_FEAT_Riprap</i>						
Const. note	<i>Const. loose riprap (Class 50) - 2 cu.yd.</i>	24	7.5	2	3		
Level	<i>P_RDWY_PLAN_NotesTx</i>						
<b>RIPRAP, EXTG.</b>							
	<i>Use LC=1</i> 			1	0		<i>rip3ex</i>
	<i>Use LC=1</i> 			1	0		<i>rip1ex</i>
Level	<i>E_HY_FEAT_Riprap</i>						

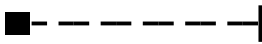

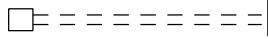
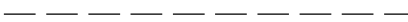

ITEM	SYMBOL	FT=	TX=	WT=	CO=	LC=	AC=
<b>RIPRAP FISH PASSAGE, CONST.</b>							
				2	0	PAT_RIPRAPFINES	
Level	P_HY_FEAT_RipRap						
<b>SATELLITE DISH</b>							
Using font 84	 Upper case #	84	6.3	1	0		
Level	E_UTIL_PHOTOG_General						
Label	Satellite dish	24	6.3	1	0		
Level	E_UTIL_PHOTOG_GeneralTx						
<b>SCHEMATIC BRACKET</b>							
				5		pro subgrade_V8	
	INTERCHANGE NAME	2	12.5	3		0	
Level	P_RDWY_PLAN_NotesTx						
<b>SECTION ARROW</b>							
				3	5	It= sectionarrow	
Level	P_ODOT_PLAN_General						
<b>SEWER PIPE, CONST.</b>							
Plug and abandon sewer pipe				1	3	pipe abandon_V8	
Sanitary line				5	2	pipe const_V8	
		24	7.5	2	2		
Level	P_UTIL_SAN_Pipe						
Label	18"-50'						
Level	P_UTIL_SAN_PipeTx						
Const. note	Inst. 18" sew. pipe - 50'	24	7.5	2	3		
	P_RDWY_PLAN_NotesTx						

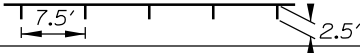
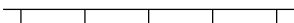
ITEM	SYMBOL	FT=	TX=	WT=	CO=	LC=	AC=
<b>SEWER PIPE, EXISTING</b>							
Sanitary sewer pipe				1	2	pipe	extg_V8
Level	E_UTIL_SAN_Pipe						
Label		24	6.3	1	2		
Level							
Descriptive text level	E_UTIL_SAN_FlowTx						
Storm sewer pipe				1	1	pipe	extg_V8
Level	E_HY_STORM_Pipe						
Label		24	6.3	1	1		
Level	E_HY_STORM_PipeTx						
Descriptive text level	E_HY_STORM_DescriptiveTx						
<b>SHEET NO.</b>							
	2B-3	2	12.5	3	4		
Level	P_RDWY_PLAN_NotesTx						
<b>SHEET TITLES</b>							
NOTE: For sheet titles copy from PlansV8.dgn or use SeedV8.nam							
<b>SIDEWALK, CONST.</b>							
				1	3		0
Level	P_RDWY_ROAD_Sidewalk						
Const. note	Const. P.C. conc. (Or asph. conc.) walk	24	7.5	2	3		
Level	P_RDWY_PLAN_NotesTx						
<b>SIDEWALK, EXISTING</b>							
				1	2		0
Level	E_RDWY_ROAD_Sidewalk						
Label		24	6.3	1	2		
Level	E_RDWY_ROAD_GeneralTx						



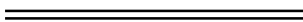
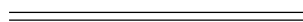

ITEM		SYMBOL	FT=	TX=	WT=	CO=	LC=	AC=
<b>SIDEWALK RAMP, CONST.</b>								
		(Ramp type)			3	3		
Level	P_RDWY_ROAD_Sidewalk							
Const. note	Const. sidewalk ramp		24	7.5	2	3		
Level	P_RDWY_PLAN_NotesTx							
<b>SIDEWALK RAMP. EXISTING</b>								
		(Ramp type)			1	2		
Level	E_RDWY_ROAD_Sidewalk							
Label			24	6.3	1	2		
Level	E_RDWY_ROAD_GeneralTx							
<b>SIGN, CONST.</b>								
Public					3	3	signpb	
Using font 84		 Upper case W	84	6.3	1	3		
Using font 84		 Lower case y	84	6.3	1	3		
Level	P_TRAF_SIGN_General							
<b>SIGN, EXISTING</b>								
Public					1	2	signpb	
Level	E_TRAF_SIGN_PublicSign							
Private					1	2	signpr	
Using font 84		 Upper case W	84	6.3	1	2		
Using font 84		 Lower case y	84	6.3	1	2		
Level	E_TRAF_SIGN_PrivateSign							
Label, public	Symbol text: Do Not Enter, Wording text: "Speed 55"		24	6.3	1	5		
Label, private			24	6.3	1	5		
Level	E_TRAF_SIGN_SigningTx							
<b>SIPHON &amp; SIPHON BOX, CONST.</b>								
					5	3	pipe const_V8	
Level	P_HY_STORM_General							
Const. note	Const. siphon box Inst. 12" siphon pipe - 20' Tr. exc. - 2 cu. yd.		24	7.5	2	3		
Level	P_RDWY_PLAN_NotesTx							





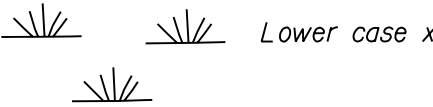

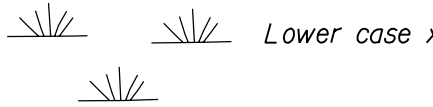



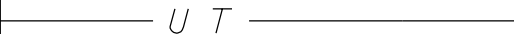
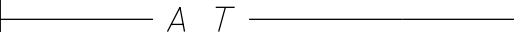

ITEM	SYMBOL	FT=	TX=	WT=	CO=	LC=	AC=
<b>SIPHON &amp; SIPHON BOX, EXTG.</b>							
				1	1	pipe extg_V8	
Level	E_HY_STORM_General						
Label		24	6.3	1	3		
Level	E_HY_STORM_GeneralTx						
<b>SLOPE LINE, PROPOSED &amp; EXTG.</b>							
Cut				1	3	3	
Fill				1	3	1	
Level	P_RDWY_ROAD_Slope						
Label		24	6.3	1	3		
Level	P_RDWY_ROAD_SlopeTx						
<b>SNOW FENCE, PERM., CONST.</b>							
				3	3	snow fence perm_V8	
Level	P_RDWY_ROAD_Fence						
Const.note	Const. snow fence	24	7.5	2	3		
Level	P_RDWY_PL AN_NotesTx						
<b>SNOW FENCE, PERM., EXTG.</b>							
				1	2	snow fence perm_V8	
Level	E_RDWY_ROAD_Fence						
Label		24	6.3	1	2		
Level	E_RDWY_ROAD_FenceTx						
<b>SNOW FENCE, PORTABLE, CONST.</b>							
				3	3	snow fence port_V8	
Level	P_RDWY_ROAD_Fence						
Const.note	Const. portable snow fence	24	7.5	2	3		
Level	P_RDWY_PL AN_NotesTx						
<b>SNOW FENCE, PORTABLE, EXTG.</b>							
				1	2	snow fence port_V8	
Level	E_RDWY_ROAD_Fence						
Label		24	6.3	1	2		
Level	E_RDWY_ROAD_FenceTx						





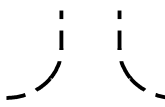









ITEM	SYMBOL	FT=	TX=	WT=	CO=	LC=	AC=
<b>SOUND WALL, CONST.</b>							
				3	3	<i>barrier median_V8</i>	
<i>Level</i>	<i>P_GT_WALL_Sound</i>						
<i>Const. note</i>	<i>Const. sound wall</i>	24	7.5	2	3		
<i>Level</i>	<i>P_RDWY_PLAN_NotesTx</i>						
<b>SOUND WALL, EXISTING</b>							
				1	0		
<i>Level</i>	<i>E_GT_WALL_Sound</i>						
<i>Label</i>	<i>Type of wall &amp; size</i>	24	6.3	1	0		
<i>Level</i>	<i>E_GT_WALL_GeneralTx</i>						
<p>NOTE:  Survey will show a single line for extg. sound wall  and note which side the shot was taken and the width  The Drafter will copy parallel for the width.</p>							
<b>SPRING</b>							
				1	1		
<i>Level</i>	<i>E_HY_WATER_Spring</i>						
<i>Label</i>	<i>Belknap Springs</i>	24	6.3	1	1		
<i>Level</i>	<i>E_HY_WATER_GeneralTx</i>						
<b>SPRINKLER SYSTEM, EXTG.</b>							
<i>Using font 84</i>	 <i>Upper case K</i>	84	6.3	1	1		
<i>Level</i>	<i>E_LDSC_IRR_General</i>						
<i>Label</i>		24	6.3	1	1		
<i>Level</i>	<i>E_LDSC_IRR_GeneralTx</i>						
<b>STREAM</b>							
				1	1	<i>stream_V8</i>	
<i>Level</i>	<i>E_HY_WATER_ChannelCL</i>						
<i>Label</i>		24	6.3	1	1		
<i>Level</i>	<i>E_HY_WATER_GeneralTx</i>						









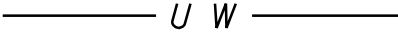

ITEM	SYMBOL	FT=	TX=	WT=	CO=	LC=	AC=
<b>STRIPING, PROPOSED</b>							
	— — —			3	0,4		
Level	P_RDWY_ROAD_Striping						
Notes	(From StripeV8.dgn)	24	7.5	2	3		
Level	P_RDWY_ROAD_StripingTx						
<b>SUBSURFACE DRAIN PIPE</b>							
(Scale 0.75)	-----			5	3	pipe	const_V8
Level	P_HY_STORM_Pipe						
Const. note	Const. subsurface drain pipe - 7'	24	7.5	2	3		
Level	P_RDWY_PLAN_NotesTx						
<b>SUMP, CONST.</b>							
	●			1	3	sumpmh	
Level	P_HY_STORM_MH						
<b>SUMP, EXISTING</b>							
	○			1	0	sump	
Using font 84	○ Lower case x	84	6.3	1	0		
Level	E_HY_STORM_GeneralTx						
<b>SURVEY USES</b>							
Instrument #/Bk. Pg. label		24	6.3	1	4		
	Label looks like INSTR. # 1234567/Bk.1234 Pg.1234						
Monuments found	○			1	4	fdmon	
Level	E_SURV_MON_FdMon						
Label	Fd. iron rod, iron pipe, pipe, rod, stone, cap, etc. Northing Easting	2	6.3	1	4		
Level	E_SURV_MON_FdMonTx						
Monuments set	●			1	3	setmon	
Label	Set iron rod, iron pipe, pipe, rod, stone, cap, etc. Northing Easting	2	6.3	1	3		
Triangulation station/GPS	☆			1	4	fdgps	
Label	Includes type, N, E, elev.	24	6.3	1	4		

ITEM	SYMBOL	FT=	TX=	WT=	CO=	LC=	AC=
<b>SURVEY USES CONT'D</b>							
<i>Traverse/Control points</i>				1	3		
<i>Label, set or found</i>		24	6.3	1	3		
	<i>Set iron rod, iron pipe, pipe, rod, stone, cap, etc. Northing Easting</i>						
<b>SWALE, SWAMP, BOG, CONST.</b>							
				3	3	<i>swampconst</i>	
<i>Using font 84</i>		84	4.5	3	3		
<i>Level</i>	<i>P_LDSC_WTLAND_General</i>						
<i>Const. note</i>	<i>Const. bio-swale Exc. - 100 cu. yd.</i>	24	7.5	2	3		
<i>Level</i>	<i>P_RDWY_PLAN_NotesTx</i>						
<b>SWALE, SWAMP &amp; BOG EXTG. ALSO SEE WETLAND</b>							
				1	1	<i>swampconst</i>	
<i>Using font 84</i>		84	4.5	1	1		
<i>Level</i>	<i>E_LDSC_WTLAND_General</i>						
<i>Label</i>		24	6.3	1	1		
<i>Level</i>	<i>E_LDSC_WTLAND_GeneralTx</i>						
<b>TELEPHONE UTILITIES, CONST.</b>							
<i>Line (Under ground)</i>				3	6	<i>ug Telephone_V8</i>	
<i>Level</i>	<i>P_UTIL_COMM_UGLine</i>						
<i>Line (Above ground)</i>				3	6	<i>ag Telephone_V8</i>	
<i>Level</i>	<i>P_UTIL_COMM_OHLine</i>						
<i>Const. note</i>	<i>Inst. telephone cable (By others)</i>	24	7.5	2	3		
<i>Level</i>	<i>P_RDWY_PLAN_NotesTx</i>						

ITEM	SYMBOL	FT=	TX=	WT=	CO=	LC=	AC=
<b>TELEPHONE UTILITIES, CONST. CONT'D</b>							
<i>Cabinet</i>	<input type="checkbox"/>			3	6	<i>risut</i>	
<i>Using font 84</i>	<input type="checkbox"/> <i>Upper case K</i>	84	6.3	3	6		
<i>Level</i>	<i>P_UTIL_COMM_General</i>						
<i>Const. note</i>	<i>Inst. tel. cabinet (By others)</i>	24	7.5	2	3		
<i>Level</i>	<i>P_RDWY_PL AN_NotesTx</i>						
<i>Manhole</i>				1	6	<i>MHconst</i>	
<i>Phone booth</i>	 <i>Lower case k</i>	84	6.3	3	6	<i>pbooth</i>	
<i>Riser</i>	<input type="checkbox"/>			3	6	<i>risut</i>	
<i>Using font 84</i>	<input type="checkbox"/> <i>Upper case K</i>	84	6.3	3	6		
<i>Vault</i>	<input type="checkbox"/>			3	6	<i>inextc</i>	
<i>Using font 84</i>	<input type="checkbox"/> <i>Upper case H</i>	84	6.3	3	6		
<i>Level</i>	<i>P_UTIL_COMM_General</i>						
<b>TELEPHONE UTILITIES, EXISTING</b>							
<i>Line (Under ground)</i>				1	6	<i>ug Telephone_V8</i>	
<i>Level</i>	<i>E_UTIL_COMM_UGLine</i>						
<i>Line (Above ground)</i>				1	6	<i>ag Telephone_V8</i>	
<i>Level</i>	<i>E_UTIL_COMM_OHLine</i>						
<i>Cabinet</i>	<input type="checkbox"/> <i>Tel. cab.</i>			1	6	<i>risut</i>	
<i>Using font 84</i>	<input type="checkbox"/> <i>Upper case K</i>	84	6.3	1	6		
<i>Label</i>		24	6.3	1	6		
<i>Manhole</i>	 <i>Tel. M.H.</i>			1	6	<i>mhecomm</i>	
<i>Using font 84</i>	 <i>Lower case b</i>	84	6.3	1	6		
<i>Phone booth</i>	 <i>Lower case k</i>	84	6.3	1	6	<i>pbooth</i>	
<i>Riser</i>	<input type="checkbox"/> <i>Tel. riser</i>			1	6	<i>risut</i>	
<i>Using font 84</i>	<input type="checkbox"/> <i>Upper case K</i>	84	6.3	1	6		
<i>Vault</i>	<input type="checkbox"/>			1	6	<i>inextc</i>	
<i>Using font 84</i>	<input type="checkbox"/> <i>Upper case H</i>	84	6.3	1	6		
<i>Level</i>	<i>E_UTIL_COMM_General</i>						

ITEM	SYMBOL	FT=	TX=	WT=	CO=	LC=	AC=	
<b>TEMP. CONNECTION</b>								
				5	3	<i>approach const_v8</i>		
<i>Level</i>	<i>P_RDWY_ROAD_Approach</i>							
<i>Const. note</i>	<i>Const. temp. connection</i>	24	7.5	2	3			
<i>Level</i>	<i>P_RDWY_PL AN_NotesTx</i>							
<b>TEST BORE or BORING TARGET, EXTG.</b>								
				1	5	<i>DET_TARGET</i>		
<i>Level</i>	<i>E_GT_SOIL_Testbore</i>							
<i>Label</i>	<i>Test bore #123</i>	24	6.3	1	0			
<i>Level</i>	<i>E_GT_SOIL_TestboreTx</i>							
<b>TESTPIT TARGET, EXTG.</b>								
				1	5	<i>DET_TESTPIT</i>		
<i>Level</i>	<i>E_GT_SOIL_Testbore</i>							
<i>Label</i>	<i>Test bore #123</i>	24	6.3	1	0			
<i>Level</i>	<i>E_GT_SOIL_TestboreTx</i>							
<b>TITLE BLOCK</b>								
<i>Level</i>	<i>P_RDWY_PL AN_TitleBlock</i>							
<b>TRAFFIC SIGNAL, CONST.</b>								
							<i>m29pmse</i>	
<i>Level</i>	<i>P_TRAF_SIGNAL_Equipment</i>							
<i>Const. note</i>	<i>Inst. traffic signal (For drg. nos., see sht. 1)</i>	24	7.5	2	3			
<i>Level</i>	<i>P_RDWY_PL AN_NotesTx</i>							

ITEM	SYMBOL	FT=	TX=	WT=	CO=	LC=	AC=
<b>TRAFFIC SIGNAL, EXISTING</b>							
	<i>See examples sheet AP3</i>						
<i>Loop detector</i>				1	5		<i>trloop</i>
<i>Mast arm</i>				1	5		0
<i>Ped. pole</i>				1	5		<i>polsig</i>
<i>Signal control box</i>				1	5		<i>sigcab</i>
<i>Signal head</i>				1	5		<i>sighead</i>
<i>Using font 84</i>	 <i>Upper case %</i>	84	6.3	1	5		
<i>Signal junction box</i>							<i>jbsig</i>
<i>Using font 84</i>	 <i>Lower case e</i>	84	6.3	1	5		
<i>Signal pole</i>				1	5		<i>polsig</i>
<i>Signal wire</i>				1	5		0
<i>Level</i>	<i>E_TRAF_SIGNAL_Equipment</i>						
<i>Label</i>	<i>Sig. cont. box, Sig., Ped. pole</i>	24	6.3	1	5		
<i>Level</i>	<i>E_TRAF_SIGNAL_SignalTx</i>						
<b>TRAFFIC TEXT</b>							
	<i>Sign info./Traffic features</i>	24	6.3	1	5		
<i>Level</i>	<i>E_TRAF_SIGN_SigningTx</i>						
<b>TREE, EXISTING</b>							
<i>Coniferous</i>	  <i>ODOT</i> <i>LISCAD</i>			1	2		<i>treconi</i>
<i>Using font 84</i>	 <i>Upper case V</i>	84	7.5	1	2		
<i>Level</i>	<i>E_LDSC_VEG_Conifer</i>						
<i>Deciduous</i>	  <i>ODOT</i> <i>LISCAD</i>			1	2		<i>tredec</i>
<i>Using font 84</i>	 <i>Upper case U</i>	84	7.5	1	2		
<i>Level</i>	<i>E_LDSC_VEG_Deciduous</i>						

ITEM	SYMBOL	FT=	TX=	WT=	CO=	LC=	AC=
<b>TREE, EXISTING CONT'D</b>							
Tree line				1	2	<i>tree line_v8</i>	
Level	<i>E_LDSC_VEG_General</i>						
Label (Dia. at breast height) (Size in inches - Type)	12" DBH - Fir	24	6.3	1	2		
Level	<i>E_LDSC_VEG_GeneralTx</i>						
<b>UTILITIES, EXISTING</b>							
	<i>(See utility type)</i>						
<b>VEGETATION, EXISTING</b>							
Brush, hedge, lawn				1	2	<i>brush line_v8</i>	
Level	<i>E_LDSC_VEG_Planted</i>						
Label	Brush, type of hedge, lawn	24	6.3	1	2		
	<i>E_LDSC_VEG_PlantedTx</i>						
<b>"V" NO.</b>							
Place in file with title block (keynum.nam)	28V-150	2	12.5	3	3		
Level	<i>P_ODOT_PLAN_General</i>						
<b>WATER UTILITIES, CONST.</b>							
Line (Under ground)				3	1	<i>ug Water_v8</i>	
Level	<i>P_UTIL_WTR_Pipe</i>						
Line (Above ground)				3	1	<i>ag Water_v8</i>	
Level	<i>P_UTIL_WTR_Pipe</i>						
Const. note	Inst. 6" water line - 25'	24	7.5	2	3		
Level	<i>P_RDWY_PLAN_NotesTx</i>						
Meter				3	1	<i>metwtr</i>	
Using font 84	 Upper case B	84	6.3	3	1		
Valve				3	1	<i>valwtr</i>	
Using font 84	 Upper case E	84	6.3	3	1		
Vault				3	1	<i>inextc</i>	
Using font 84	 Upper case H	84	6.3	3	1		
Level	<i>P_UTIL_WTR_General</i>						



ITEM	SYMBOL	FT=	TX=	WT=	CO=	LC=	AC=
<b>WATER UTILITIES, EXISTING</b>							
Line (Under ground)	————— U W —————			1	1	ug Water_V8	
Level	E_UTIL_WTR_Pipe						
Line (Above ground)	————— A W —————			1	1	ag Water_V8	
Level	E_UTIL_WTR_Pipe						
Label		24	6.3	1	1		
Meter	W.M. □			1	1	metwtr	
Using font 84	□ Upper case B	84	6.3	1	1		
Valve	W.V. ∅			1	1	valwtr	
Using font 84	∅ Upper case E	84	6.3	1	1		
Vault	□			1	1	inextc	
Using font 84	□ Upper case H	84	6.3	1	1		
Level	E_UTIL_WTR_General						
<b>WEIR &amp; TIDE GATE</b>							
	E_HY_FEAT_General			1	1		
Level							
Label		24	6.3	1	1		
Level	E_HY_FEAT_GeneralTx						
<b>WELL OR PUMP HOUSE, EXTG.</b>							
	Well □			1	2	well	
Using font 84	□ Lower case w	84	6.3	1	2		
Level	E_UTIL_WTR_General						
Label		24	6.3	1	1		
Level	E_UTIL_WTR_GeneralTx						
<b>WELL, MONITOR, EXISTING</b>							
	M.W. □			1	0	monwell	
Using font 84	□ Lower case w	84	6.3	1	0		
Level	E_GT_WATER_MonWell						
Label		24	6.3	1	0		
Level	E_GT_WATER_MonWellTx						

ITEM	SYMBOL	FT=	TX=	WT=	CO=	LC=	AC=
<b>WETLANDS,EXTG.</b>							
	<i>Also see swale</i>						
<i>Line</i>				1	1	<i>wet edge_V8</i>	
<i>Level</i>	<i>E_LDSC_WTLAND_General</i>						
<i>Label</i>		24	6.3	1	1		
<i>Level</i>	<i>E_LDSC_WTLAND_GeneralTx</i>						

ITEM	SYMBOL	FT=	TX=	WT=	CO=	LC=	AC=
<b>NOTES, ORDER OF</b>							
		24	7.5	2	3	0	
Level	P_RDWY_PL AN_NotesTx						
<p> <i>Sta.00+00, Lt. or Rt.</i>  <i>Const. appr.</i>  <i>Const. street (Or road) connection</i>  <i>Remove (Or abandon) manhole</i>  <i>Const. (Reconst. or adjust) manhole</i>  <i>Remove (Or abandon) inlet</i>  <i>Adjust or cap inlet</i>  <i>Const. type "G-2" inlet</i>  <i>    With 8" sump</i>  <i>Const. precast sump, 9' deep</i>  <i>Remove (Or abandon) pipe</i>  <i>18" culv. pipe - 37' (In pl.)</i>  <i>Remove end section, Lt. or Rt.</i>  <i>    Remove - 5', Lt. or Rt.</i>  <i>    Extend - 8', Lt. or Rt., 5' depth</i>  <i>Inst. 12" sew. pipe - 20'</i>  <i>    5' depth</i>  <i>Inst. 18" sew. pipe - 60'</i>  <i>    5' depth</i>  <i>Inst. lateral section with cleanout gate</i>  <i>Inst. 3 piece 30° elbow - 2</i>  <i>Inst. slip joint</i>  <i>Inst. slope anchor</i>  <i>Const. subgrade cutoff drain</i>  <i>Const. drainage curb</i>  <i>Const. paved end slope, Lt. or Rt.</i>  <i>Const. loose riprap (Class 50) - 50 cu. yd.</i>  <i>Class 1300-6.3 conc. - 9.4 cu. yd.</i>  <i>Reinf. - 350 k</i>  <i>Drainage geotextile type "?" - 42 sq. yd.</i>  <i>Filter blanket - 25 cu. yd.</i>  <i>Gravel drain matl. - 25 cu. yd.</i>  <i>Trench resurf. - 120 sq. yd.</i>  <i>Emb. fdt. exc. - 30 cu. yd.</i>  <i>Granular backfill or bedding matl.</i>  <i>Gen. exc. - 30 cu. yd.</i>  <i>Dt. exc. - 30 cu. yd.</i>  <i>Toe tr. exc. - 30 cu. yd.</i>  <i>(For details, see sht. 2B)</i>  <i>(See drg. no. RD610)</i>  <i>(For drg. nos., see sht. 1)</i>  <i>(Earthwork incl. in main rdwy. distr.)</i> </p>							
<p style="text-align: right;"> <b>NOTE:</b>  <i>For guardrail notes, see sht. 28</i>  <i>For mailbox notes, see sht. 33</i> </p>							



# TRAFFIC SIGNAL, EXISTING

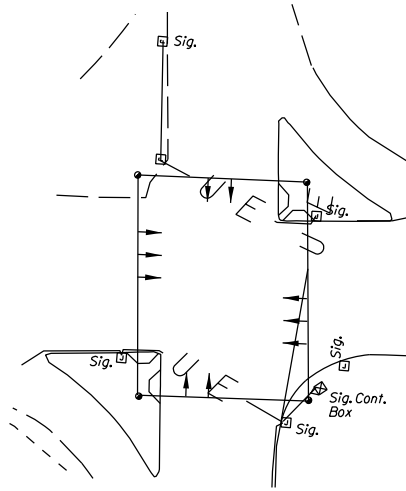

Span Wire Signal

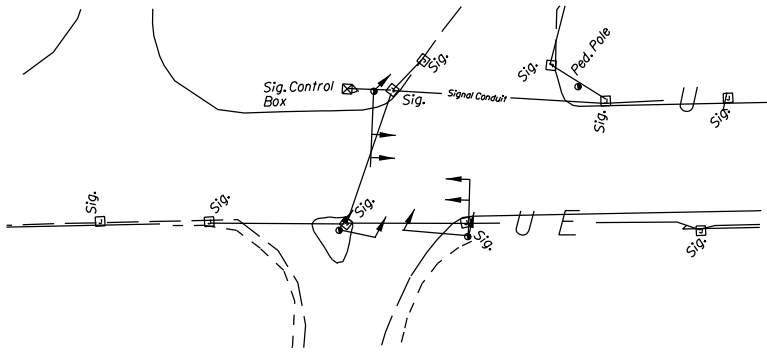

Mast Arm Signal

# HOW DESCRIPTIVE TEXT WORKS

## Working Base Map

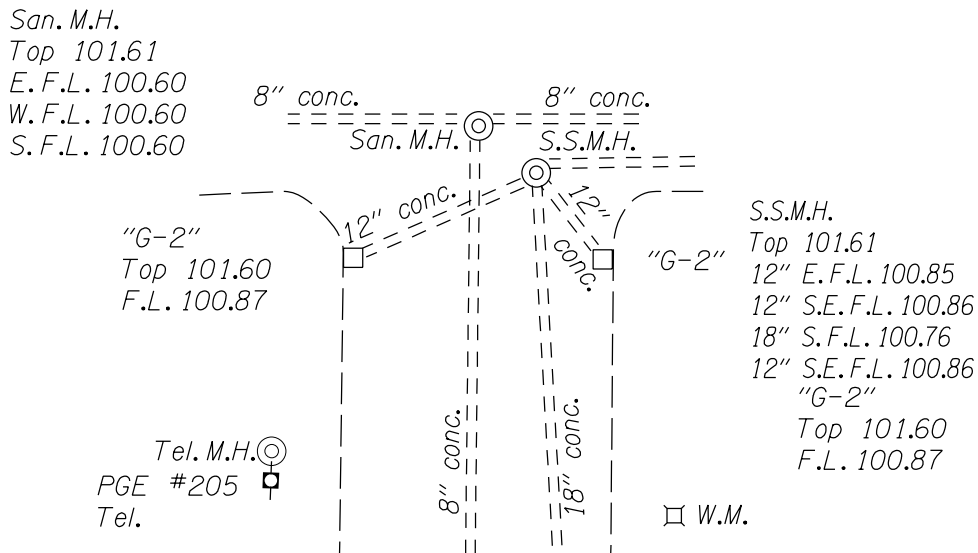

Descriptive text on levels, E\_UTIL\_SAN\_FlowTx & E\_HY\_STORM\_DescriptiveTx

## Contract Plan Base Map

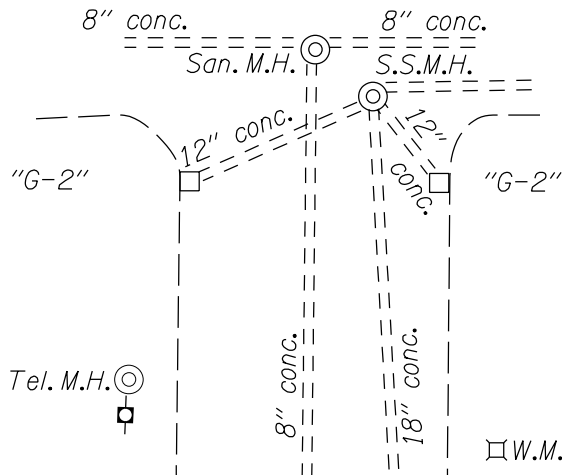

Levels E\_UTIL\_SAN\_FlowTx & E\_HY\_STORM\_DescriptiveTx turned off

**ORDER OF SHEETS**

ROADWAY

Title sheet ..... 1  
 Continuation sheet ..... 1A  
     Index Of Sheets, Standard Drawings  
     Standard Drawings  
 Plan Sheet Layout ..... 1B  
 Typical Sections ..... 2, 2A, 2A-2, etc.  
 Details ..... 2B  
 Traffic Control ..... 2C  
     Details, Detour, Plans  
 Pipe Data ..... 2D

NOTE: If there is only 1 sheet of typicals then the details will be 2A,  
 Traffic Control 2B, etc.

Plans And Profile ..... 3 Thru ?  
     Combined Plans And Profile  
 Broken Out Sheets  
 Alignment Plan ..... 1st  
 General Construction ..... 2nd  
 General Construction Notes (If needed) ..... 3rd  
 Detour Plan (If needed)..... 3rd or 4th  
 Drainage And Utilities ..... 4th or 5th  
 Drainage And Utilities Notes (If needed) ..... 5th or 6th  
 Removal ..... 6th or 7th  
 Profile ..... 7th or 8th

GEO/HYDRO

Erosion Control ..... "GA" Series  
     Details  
     Plans  
 Subsurface Information ..... "GB" Series  
     Details  
     Plans  
 Retaining Walls ..... "GC" Series  
     Details  
     Plans  
 Sound Walls ..... "GD" Series  
     Details  
     Plans  
 Culverts ..... "GE" Series  
     Details  
     Plans  
 Fish Passage ..... "GF" Series  
     Details  
     Plans  
 Temporary Water Management ..... "GG" Series  
     Details  
     Plans

## ORDER OF SHEETS CONT'D

### GEO/HYDRO

<i>Streambank Stabilization</i> .....	<i>"GH" Series</i>
<i>Details</i>	
<i>Plans</i>	
<i>Stormwater</i> .....	<i>"GJ" Series</i>
<i>Details</i>	
<i>Plans</i>	
<i>Landslide Correction/Rockfall</i> .....	<i>"GK" Series</i>
<i>Details</i>	
<i>Plans</i>	
<i>HazMat</i> .....	<i>"GL" Series</i>
<i>Details</i>	
<i>Plans</i>	
<i>Material Source and Disposal Site</i> .....	<i>"GM" Series</i>
<i>Details</i>	
<i>Plans</i>	
<i>Roadside Development</i> .....	<i>"GN" Series</i>
<i>Details</i>	
<i>Wetland</i>	
<i>Irrigation</i>	
<i>Planting Details and Plant List</i>	
<i>Plant Log</i>	
<i>Construction Details</i>	
<i>Plans</i>	
<i>Contour Grading and Typical Sections (Incl. Wetland Development and</i>	
<i>General Project Areas)</i>	
 <i>Irrigation</i>	
<i>Planting</i>	

### BRIDGE

### TRAFFIC

<i>Striping</i> .....	<i>ST 1, ST 2. etc.</i>
<i>Details</i>	
<i>Plans</i>	
<i>Permanent Signing</i>	
<i>Details</i>	
<i>Plans</i>	
<i>Sign and Post Data Table</i>	
<i>Illumination Plans</i>	
<i>Temporary Illumination and Removal Plan</i>	
<i>Details</i>	
<i>Plans</i>	
<i>Legend</i>	
<i>Metal Light Poles</i>	
<i>Signal Plans</i>	
<i>Signal Plans (Legend and Phase Diagram)</i>	
<i>Detector Plans (CCTV Plans and CCTV Details)</i>	
<i>Existing Utility Plans</i>	
<i>Interconnect Plans</i>	
<i>Temporary Signal Plans</i>	
<i>Ramp Meter Plans</i>	
<i>Variable Message Signs and Miscellaneous Plans</i>	



PLOTUSENAME

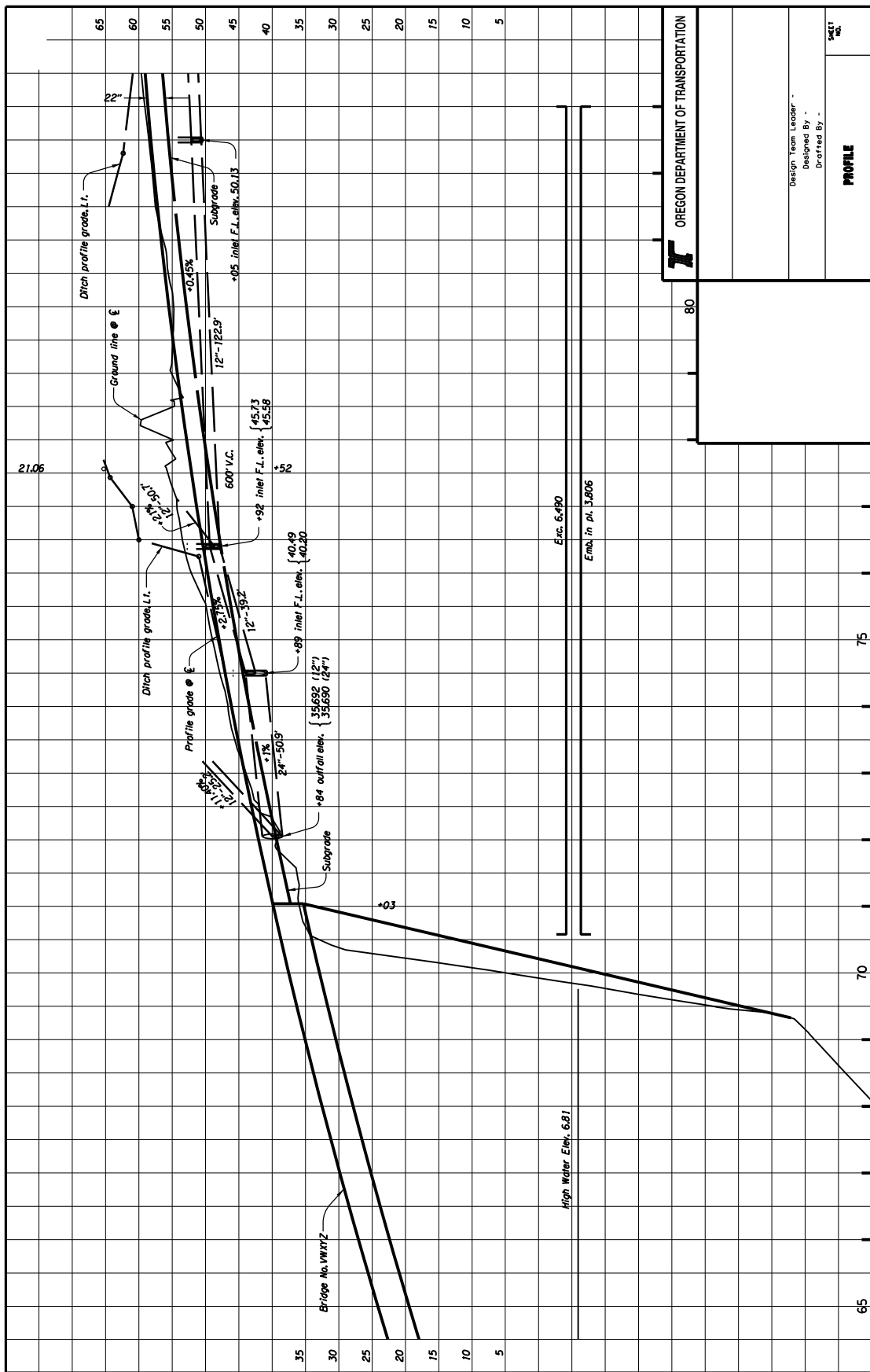

**OREGON DEPARTMENT OF TRANSPORTATION**

Design Team Leader -  
 Designed By -  
 Drafted By -

**PROFILE**

SHEET NO.

THIS IS THE FILE NAME LOCATION \*\*\*\*\* DD-MMM-YYYY HHMM \*\*\*\*\* VIEW 2

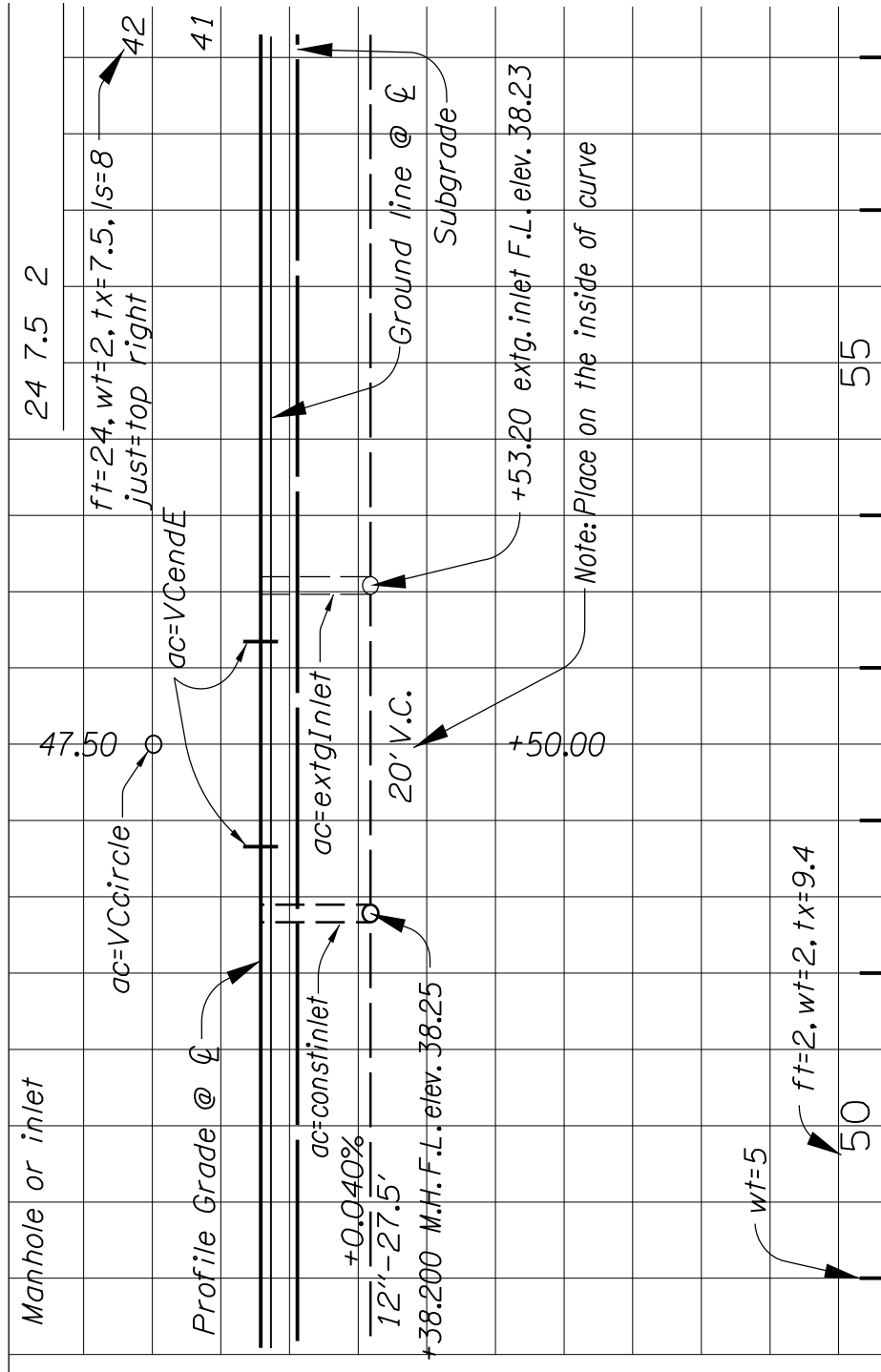

## FONT 84 CHARACTERS

A	■	Q	CON. WALK
B	□	R	CON. DRIVE
C	☀	S	TYPE C
D	⊙	T	GRAVEL
E	⊙	U	☁
F	•	V	☀
G	⊙	W	—
H	□	X	□
I	⊙	Y	BRICK
J	△	Z	s
K	□	@	☉
L	AC	#	⚡
M	↓	\$	■
N	CLINK	%	⋮
O	WOOD	°	-x-x-
P	CON. CULV.	&	-x-x-

### NOTE:

For font 84 characters, weight and color has to be set first.

a	⬆	n	↗
b	⊙	o	↕
c	◐	p	↕
d	⊙	q	↕
e	□	r	↑ <sup>GAS</sup>
f	○	s	●
g	●	t	☀
h	▲	u	△
i	⊙	v	☀
j	◇	w	□
k	⌒	x	○
l	↖	y	—
m	↑	z	⬇

## LETTER WHEEL

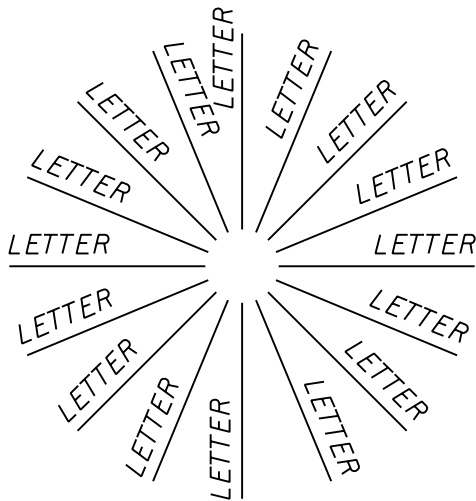

*This Is A Guide To How Text Will Be Read On Plan Sheets. The Exceptions To This Are Stationing, Station Flags, Lane Dimensions, Approach Labels, Bridge Ends, Driveway Labels Which Are To Be Read Ahead On Line.*

# SHEET NUMBERING WITH MATCH LINES

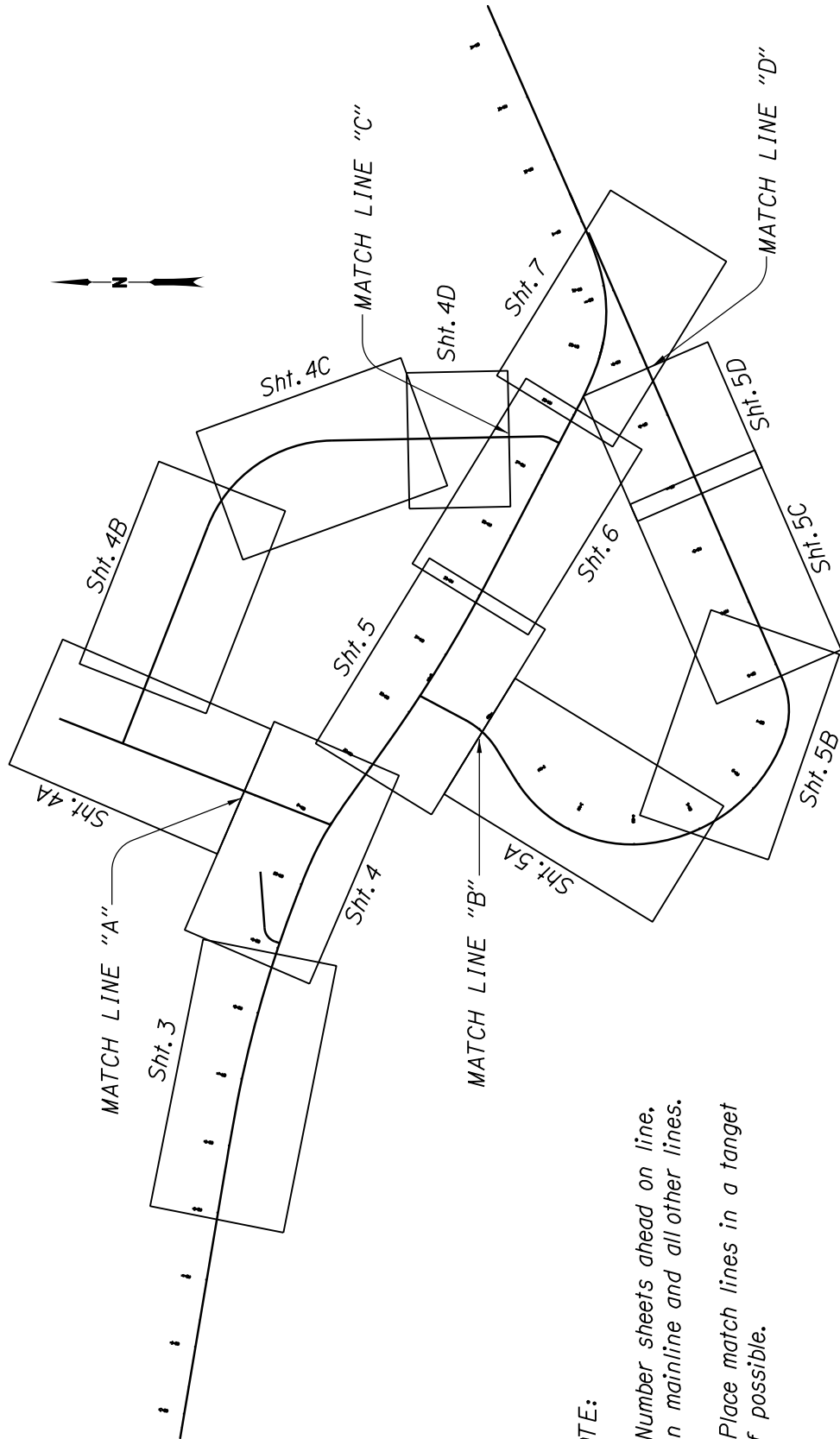

**NOTE:**

1. Number sheets ahead on line, on mainline and all other lines.
2. Place match lines in a target if possible.

**EXAMPLE OF ALIGNMENT LINE WITH BARRIER**

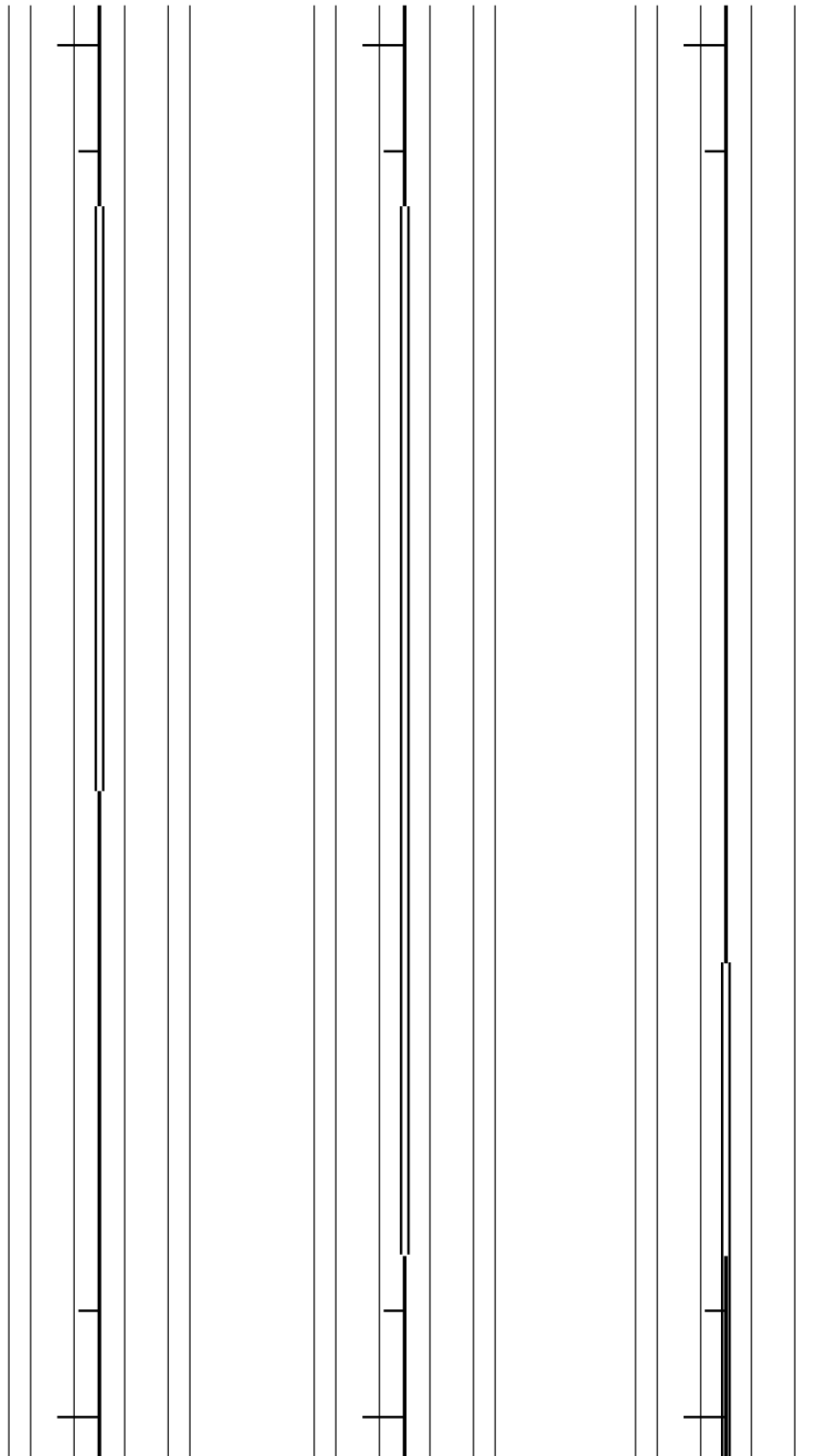

**AMOUNT OF SHEET OVERLAP  
EXAMPLE**

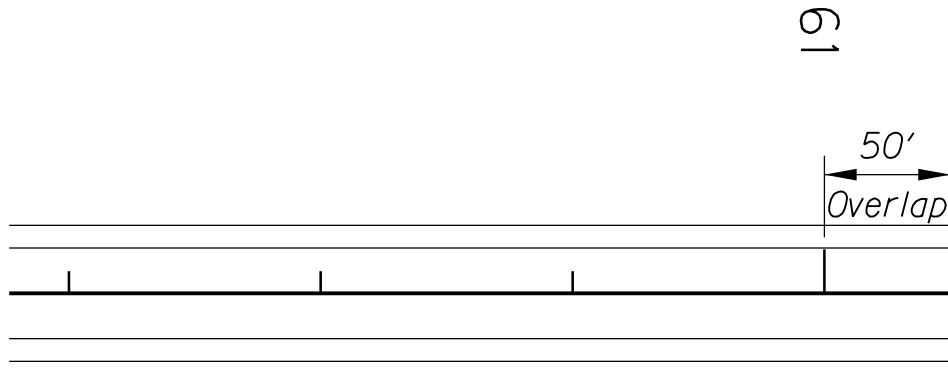

**FIRST SHEET**

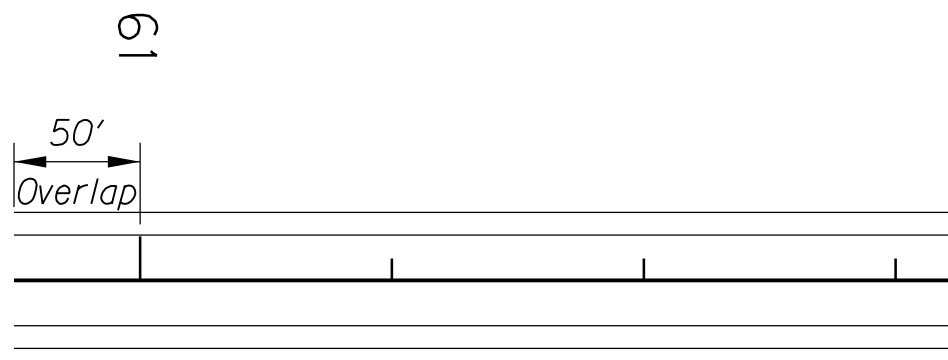

**NEXT SHEET**

37V-88

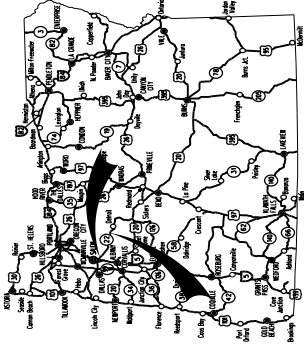

Overall Length Of Project - XX.XX Miles

**ATTENTION:**  
Oregon Law Requires You To Follow Rules Adopted By The Oregon Utility Notification Center. Those Rules Are Set Forth In OUR 952-001-000 Through OUR 952-001-0090. You May Obtain Copies Of The Rules By Calling The Center. Above The Telephone Number For The Oregon Utility Center Is 903-232-1981.

LET'S ALL  
WORK TOGETHER  
TO MAKE THIS  
JOB SAFE

Revised Date: 07-15-2011 - Revised OTC Block

STATE OF OREGON  
DEPARTMENT OF TRANSPORTATION  
PLANS FOR PROPOSED PROJECT  
STRUCTURES

**OR22: NAME OF PROJECT**  
**HIGHWAY**

COUNTY  
APRIL 2004

INDEX OF SHEETS	
SHEET NO.	DESCRIPTION
I	Title Sheet
IA	Index Of Sheets Cont'd. & Std. Dwg. Nos.

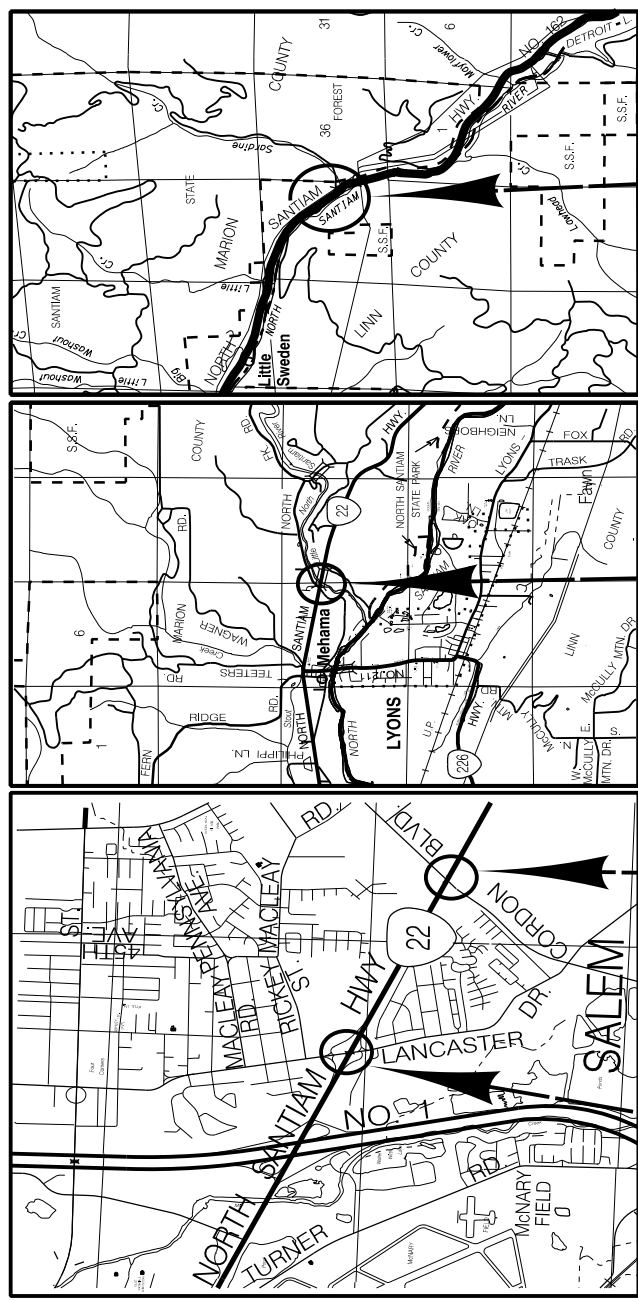

T. 8 S., R. 2 W.,  
T. 9 S., R. 2 E.,  
T. 9 S., R. 4 E., W.M.

**PROJECT**  
**X-BHF-STP-S162026)**  
M.P. 40.33

**PROJECT**  
**X-BHF-STP-S162026)**  
M.P. 23.28

**PROJECT**  
**X-BHF-STP-S162026)**  
M.P. 4.03

**PROJECT**  
**X-BHF-STP-S162026)**  
M.P. 2.82

SHEET AP13

**OREGON TRANSPORTATION COMMISSION**  
 Chair: Gail Achterman  
 Commissioner: Mary F. Olson  
 Commissioner: David Lohman  
 Commissioner: Mark Frohnmayer  
 Commissioner: Tammy Boney  
 Director of Transportation: Matthew L. Corbett

These plans were developed using ODOT design standards. Exceptions to these standards, if any, have been submitted and approved by the ODOT Chief Engineer or their delegated authority.

Approving Authority: \_\_\_\_\_  
 Signature & date  
 \_\_\_\_\_  
 Print name and title

Concurrence by ODOT Chief Engineer  
 \_\_\_\_\_

NAME	PROJECT NUMBER	SHEET NO.
NAME	X-BHF-STP-S0001000)	I
NAME		
HIGHWAY		
COUNTY		
FEDERAL HIGHWAY ADMINISTRATION		
OREGON DIVISION		

31V-88

Standard Drg. Nos.

- RD400, RD405, RD410, RD415, RD420, RD425, RD430, RD435, RD440, RD450 - Guardrail

- RD500 - Precast Conc. Barrier Pin And Loop Assembly
- RD510 - Conc. Barrier Terminal
- RD530 - Guardrail Connection To Conc. Barrier

- RD900, RD905, RD910, RD915, RD945 - Traffic Control Plans
- RD950 - Barricades
- RD955 - Temporary Impact Attenuators

- BR200 - Standard Conc. Bridge Rail (Type F)
- BR203 - Standard Transition Conc. Br. Rail To Guardrail
- BR206 - Standard 2 Tube Curb Mount Rail

- TM100 - Temp. Wood Post Sizing Charts
- TM105 - Orange Flag Board Mounting Details

R/W map no.

INDEX OF SHEETS, CONT.	
SHEET NO.	DESCRIPTION
2	Details
2A Thru 2A-9 Incl.	Traffic Control Plans
3, 4	General Construction

DRAWING NO.	DESCRIPTION
<b>BRIDGE NO. 07770</b>	
64982	Plan And Elevation
64983	Bent 2 Details
64984	Crossbeam Details
64985	Bracket And Misc. Details
<b>BRIDGE NO. 08473</b>	
64986	Plan And Stage Details
64987	Longitudinal Grader Details
64988	Bent 2 Crossbeam Details
<b>BRIDGE NO. 07347</b>	
64989	Plan And Elevation
64990	"D-Beam" Details
64991	Column Bracket Details
64992	Miscellaneous Details
64993	J-Beam And J2 Beam Details
64994	J And J2 Beam Section Details
64995	Arch Bent Details
64996	Arch Bent Details
64997	Rail Details
<b>BRIDGE NO. 07964</b>	
61862	Plan And Elevation
61863	Bent 1 Details
61864	Bents 2 & 11 Details
61865	Bents 3 Thru 9 Details
61866	Bent 10 Details
61867	Bent 12 Details
61868	Bent 13 Details
61869	Bent 14 Details
61870	Bent 15 Details
61871	Bent 16 Details
64998	Rail Transition And Misc. Details

OR22: NORTH SANTIAM HWY. BRIDGE REPAIRS PROJECT NORTH SANTIAM HIGHWAY MARION COUNTY		SHEET NO. <b>1A</b>
FEDERAL HIGHWAY ADMINISTRATION	PROJECT NUMBER	
OREGON DIVISION		

Standard Drawings locate on the web at:  
[http://www.oregon.gov/ODOT/HWY/ENGSEVR/ICES/standard\\_drawings\\_home.shtml](http://www.oregon.gov/ODOT/HWY/ENGSEVR/ICES/standard_drawings_home.shtml)