

Airport Layout Plan

Report and Drawings Update

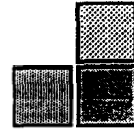

John Day State Airport

Oregon Department of Transportation - Aeronautics &
Grant County Airport Commission
John Day, Oregon

FINAL REPORT

October 1996

Prepared By

DEVCO

engineering inc.

in association with

David Miller & Associates, Airport Consultant

FINAL REPORT

JOHN DAY STATE AIRPORT

AIRPORT LAYOUT PLAN REPORT

Prepared for

STATE OF OREGON
DEPARTMENT OF TRANSPORTATION
AERONAUTICS

October 1996

Prepared by

DEVCO ENGINEERING INC.
245 NE Conifer
Corvallis, Oregon 97339
(503) 757-8991

in association with

David Miller & Associates - Airport Planning Consultant
Eugene, Oregon

and

Gazeley & Associates, Wilsonville, Oregon
Aron Faegre & Associates, Portland, Oregon

Airport Layout Plan Report

for

**John Day State Airport
John Day, Oregon**

prepared for the

**Oregon Department of Transportation
Aeronautics**

and

Grant County Airport Commission

TABLE OF CONTENTS

<u>Chapter</u>		<u>Page</u>
1	INTRODUCTION	
	STUDY OVERVIEW	1- 1
	STUDY APPROACH	1- 2
	PUBLIC INVOLVEMENT	1- 3
2	CONCLUSIONS AND RECOMMENDATIONS	
	INTRODUCTION	2- 1
	PREVIOUS PLANNING RECOMMENDATIONS	2- 1
	CURRENT ALP REPORT CONCLUSIONS	2- 2
	CURRENT ALP REPORT RECOMMENDATIONS	2- 4
3	INVENTORY AND FORECASTS	
	INTRODUCTION	3- 1
	AIRPORT LOCATION	3- 1
	Locale	3- 1
	Topography	3- 3
	Climate	3- 3
	AIRPORT HISTORY	3- 4
	SOCIOECONOMIC CONDITIONS	3- 4
	EXISTING FACILITIES	3- 6
	Airside Facilities	3- 6
	Landside Facilities	3- 9
	Airport Support Facilities	3-10
	Airport Lighting	3-11
	Airspace and Navigational Aids	3-11
	AIRPORT SERVICE AREA	3-12
	AVIATION ACTIVITY	3-13
	Based Aircraft	3-13
	General Aviation Activity	3-13
	Airfield Capacity	3-16
	LAND-USE PLANNING AND ZONING	3-20

TABLE OF CONTENTS (Continued)

<u>Chapter</u>		<u>Page</u>
4.	FACILITY REQUIREMENTS	
	INTRODUCTION	4- 1
	Airport Design Standards	4- 2
	Design Aircraft	4- 2
	Airspace	4- 3
	Instrument Approach Capabilities	4- 3
	AIRSIDE REQUIREMENTS	4- 6
	Runways	4- 6
	Runway Orientation	4- 6
	Runway Length	4- 7
	Airfield Pavements	4- 8
	Airfield Capacity	4-10
	Taxiways	4-10
	Airfield Instrumentation and Lighting	4-11
	LANDSIDE FACILITIES	4-11
	Hangars	4-11
	Local and Itinerant Apron	4-12
	Surface Access Requirements	4-13
	SUPPORT FACILITIES	4-13
	Aviation Fuel Storage	4-13
	Airport Utilities	4-14
	Security	4-14
	SUMMARY	4-15
5	AIRPORT DEVELOPMENT ALTERNATIVES AND PLANS	
	Overview	5- 1
	Instrument Approach Procedure	5- 4
	PRELIMINARY DEVELOPMENT CONCEPTS	5- 5
	RUNWAYS	5- 5
	TAXIWAY	5- 8
	Landside Development Concept #1	5- 8
	Landside Development Concept #2	5-10
	Landside Development Concept #3	5-12
	PREFERRED DEVELOPMENT ALTERNATIVE	5-12
	AIRPORT PLANS	5-20
	Airport Layout Plan	5-20
	FAR Part 77 Airspace Plan	5-23
	Land-Use Plan	5-26

TABLE OF CONTENTS (Continued)

<u>Chapter</u>		<u>Page</u>
6	CAPITAL IMPROVEMENT PROGRAM	
	AIRPORT DEVELOPMENT SCHEDULES AND	
	COST SUMMARIES	6- 2
	Short Term Development	6- 3
	Long Term Development	6- 4
	AIRPORT CAPITAL IMPROVEMENTS FINANCING	6- 8
	Third-Party Support	6- 8
7	ENVIRONMENTAL REVIEW	
	Overview	7- 1
	1994 and 2014 Noise Contours	7- 2
	Ldn Methodology	7- 5
	COMPATIBLE LAND USE	7- 6
	Other Considerations	7- 9
	ENVIRONMENTAL CHECKLIST	7-11

APPENDICES

A	Environmental Correspondence, Zoning, Noise Data
B	Pavement Evaluations

TABLE OF CONTENTS (Continued)

TABLES and FIGURES

<u>Table</u>		<u>Page</u>
3-1	Existing Facilities - John Day State Airport	3- 7
3-2	Historical Based Aircraft	3-13
3-3	Historical Airport Activity	3-15
3-4	Historical Aviation Forecasts	3-15
3-5	Updated Aviation Forecasts	3-17
4-1	FAA Runway Dimensional Standards, Airplane Design Group I/II	4- 5
4-2	Hangar and Apron Area Requirements	4-16
4-4	Facility Requirements Summary	4-17
6-1	Airport Development Costs	6- 6
7-1	Land Use Compatibility Index	7- 7
7-2	Checklist of Sources of Potential Environmental Impacts	7-11

<u>Figure</u>		<u>Page</u>
3-1	Area and Location Map	3- 2
3-2	Existing Facilities	3- 8
3-3	Forecast Based Aircraft	3-18
3-4	Forecast Aircraft Operations	3-19
5-1	Overall Airfield Development Concept	5- 7
5-2	Development Concept #1	5- 9
5-3	Development Concept #2	5-11
5-4	Development Concept #3 (Preferred Alternative)	5-13
5-5	Development Concept #3A	5-16
5-6	Concept 3A (Enlarged View)	5-17
5-7	Development Concept #3B	5-18
5-8	Concept 3B (Enlarged View)	5-19
7-1	1994 & 2014 Noise Contours	7- 3

DRAWINGS

<u>Drawing</u>		<u>Page</u>
1	Airport Layout Plan	5-21
2	FAR Part 77 Airspace Plan	5-25
3	Land-Use and Zoning Plan	5-27

Airport Layout Plan Report

for

**John Day State Airport
John Day, Oregon**

prepared for the

**Oregon Department of Transportation
Aeronautics**

and

Grant County Airport Commission

Chapter One
INTRODUCTION

STUDY OVERVIEW

The preparation of the John Day State Airport Layout Plan Report and supporting documentation has been undertaken by the State of Oregon Department of Transportation - Aeronautics Section and Grant County, to examine the existing configuration of the airport and to provide direction for future airport development. The Plan was funded with a 90 percent grant from the Federal Aviation Administration, with the remaining 10 percent participation provided by Oregon Aeronautics and Grant County. The Plan is being prepared by the consulting firm of Devco Engineering Inc., Corvallis, with David Miller & Associates, Airport Consultant, Eugene.

The decision to update the Airport Layout Plan drawings and report reflects recognition by the Airport Sponsor of a need to improve basic airfield facilities, operational efficiency and safety while providing opportunities for private investment in aviation facilities. Development of aviation facilities at John Day State Airport has progressed since the **Airport Layout Plan Report** (CH2M Hill, December 1979) was conducted. The continuous evolution of facility requirements combined with the passage of time, indicate a need to reevaluate the recommendations for airport improvements contained in the previous study and determine their validity, based upon current conditions. This ALP Report is intended to address these questions and provide a realistic development program for the airport.

STUDY APPROACH

The primary objective of the Airport Layout Plan Report is to provide a long-term development program which will yield a safe, efficient, economical, and environmentally acceptable air transportation facility for the area. As noted in the Airport Service Area section, John Day State Airport is positioned to serve a number of nearby communities and a large rural area within Grant County and adjacent counties.

The planning process requires an evaluation of the airport and a determination of what actions should be taken in the future to maintain an adequate, safe, and reliable airport facility. The review and approval of the Airport Layout Plan drawing by the Federal Aviation Administration (FAA) will enable the Sponsor to apply for federal Airport Improvement Program (AIP) grants for eligible facility improvement projects. Although competition for AIP dollars is substantial, AIP funds are an essential funding source in funding airport improvement projects at community general aviation airports.

The ability of general aviation airports to sustain an on-going program of facility improvement has been significantly compromised in recent years due to reductions in available funding at the federal level. This coupled with the difficulty most Sponsors encounter in securing the required local match for federal Airport Improvement Program (AIP) grants, often creates a significant void in the development of facilities. Recognizing these inherent limitations, it is important to note that this study will first identify unconstrained facility needs, which are based on factors such as the condition of existing facilities and the existing and projected utilization of the airport. The second part of this process is to create an implementation program which reflects the practical considerations associated with existing programs of airport improvement and development funding. Based on current conditions, it is likely that there will often be a considerable difference between unconstrained facility needs, the ability of a Sponsor to generate revenues which are adequate to support recommended improvements, and the availability of federal AIP dollars. Individual projects will often be deferred until adequate funding can be arranged; therefore, the overall prioritization of facility needs within this study becomes the primary indicator of need. The timing of specific projects will be heavily dependent on funding constraints. It should also be noted that maintaining safe primary airfield facilities will remain the highest priority of an airport sponsor; the development of new facilities will be accomplished as funding permits.

The Airport Layout Plan Report will:

- Examine inventory, forecast, and plans from the **Airport Layout Plan Report - John Day State Airport** (CH2M Hill, 1979), and update as necessary.

- Determine current airport facility requirements and their feasibility, using available information including the Airport Layout Plan Report.
- Examine previous recommendations and develop alternatives as appropriate to meet the current airport facility needs.
- Prepare an airport layout plan, airspace plan, and land-use plan for the airport and its surrounding areas.
- Schedule priorities, phase proposed developments, and estimate development costs.

PUBLIC INVOLVEMENT

During the course of the study, the Consultant prepared an Interim Summary and Draft Report leading to this Final Report. During the planning process, several supplemental evaluations were also conducted in associated with selection of a preferred alternative, primary-secondary runway status, and the preferred instrument approach runway. Following review of the Draft Report and these supplemental analyses, the Final Airport Layout Plan Report and drawing set was prepared.

The Interim Summary provided an update on the findings associated with the inventory, forecasting, facility requirements analysis, and preliminary development concepts. Following the presentation of preliminary development concepts, a number of wide-ranging discussions were held between ODOT Aeronautics staff and the Grant County Airport Commission. The primary focus of these discussions was related to selecting a specific course of action regarding future airport improvements, as related to the limited availability of funds. These issues were discussed and evaluated over a period of several months, until a preferred approach was determined.

The Draft Report provided another opportunity to review and evaluate the results and conclusions of the work effort. Public informational meetings also provided the forum for public comment and review of the documents and plans. This process provided all concerned a voice in the proceedings to ensure that a realistic and effective Airport Layout Plan and Report is developed.

The preparation of this document was financed in part by a planning grant from the Federal Aviation Administration (FAA) as provided under Section 505 of the Airport and Airway Improvement Act of 1988. The contents do not necessarily reflect the official views or policy of the FAA. Acceptance of this report by the FAA does not in any way constitute a commitment on the part of the United States to participate in any development depicted therein nor does it indicate that the proposed development is environmentally acceptable in accordance with appropriate public laws.

Airport Layout Plan Report

for

**John Day State Airport
John Day, Oregon**

prepared for the

**Oregon Department of Transportation
Aeronautics**

and

Grant County Airport Commission

Chapter Two

CONCLUSIONS and RECOMMENDATIONS

INTRODUCTION

This Airport Layout Plan Report updates the facility planning contained in the **John Day Airport Layout Plan** (1979), completed by CH2M Hill. This Study will examine the recommendations contained in the previous planning effort and evaluate changes which affect existing and future demand for aviation facilities at John Day State Airport. The adoption of this plan will supersede previous planning documents for the airport.

Note: The Federal Aviation Administration recently changed the designation of Runway 16-34, to 17-35, based on changes in magnetic alignment. Accordingly, the runway will be referred to as Runway 17-35 in existing and future evaluations, with the Runway 16-34 designation used in historic references. The designation of Runway 9-27 does not change.

PREVIOUS PLANNING RECOMMENDATIONS:

The 1979 Airport Layout Plan depicts the following recommended improvements:

- Taxiway Reflectors - Existing Taxiways
- Holding Aprons - Both Ends of Runway 16-34
- Widen and Resurface Runway 16-34 and Mid-Field Exit Taxiways

PREVIOUS PLANNING RECOMMENDATIONS (continued):

- Runway and Taxiway Markings
- Install MIREL - Runway 16-34
- Nondirectional Beacon Installation
- Land Acquisition - 2.4 Acres
- Install VASI-2 -- Runway 16
- Purchase Avigation Easements - 15.8 Acres
- Helicopter Apron
- Construct T-hangars and Taxiways
- New Runway 9-27 and Taxiways
- Expand Automobile Parking As Needed
- Extend Runway 16-34 400 feet to North and 500 feet to South
- Extend and Widen Runway 16-34 Parallel taxiway (North & South)
- Install VASI-2 -- Runway 34
- Add aircraft turnout at North end of extended runway;
- Pavement overlays on existing surfaces;
- Extend Runway 9-27 500 feet to west
- Security fencing;
- T-hangar access taxiways and add T-Hangars

During the period following adoption of the 1979 Airport Layout Plan, several facility improvements have been completed at the airport. The most significant facility improvement was the construction of Runway 9-27 (3,436 x 60 feet); the former gravel-surfaced east-west runway located at the north end of Runway 16-34 was closed, and a land exchange was conducted with the adjacent property owner. Other improvements include construction of private hangars (and access taxilanes) north of the Main Apron; relocation of the fuel island to the outer edge of the Main Apron; and construction of the aircraft apron which supports fire-related activity. No major improvements have been made to the primary runway and taxiway system or the Main Apron. No airport-based electronic navigational aids have been commissioned. Maintenance of the airfield pavements has also been conducted on a regular basis. As noted above, the numeric designation of Runway 16-34 was recently changed to 17-35.

CURRENT AIRPORT LAYOUT PLAN REPORT CONCLUSIONS

1. John Day State Airport is a Basic Utility I category airport providing service to John Day, Canyon City and the outlying area.
2. John Day State Airport currently has 24 year-round based aircraft. In recent years, an additional 5 to 7 aircraft have been based at the airport during summer fire season. The airport had approximately 5,900 aircraft operations in 1994.
3. Seasonal fire spotting and suppression aircraft (fixed- and rotor-wing) operations account for a significant portion of overall airport activity and contribute to the increase in seasonally-based aircraft.
4. The airport accommodates fixed-wing and rotor-wing medical-evacuation activity for a large geographic area.
5. Airport survey data indicates that the majority of permanently based aircraft are stored in hangars.
6. The airfield pavement surfaces are rated as follows: Runway 17-35 - 8,000 pounds for aircraft with single wheel loading; Runway 9-27 - 12,000 pounds SW. The existing pavement on Runway 17-35, the parallel taxiway, and the main apron are in poor condition. The pavement surface on Runway 9-27 is in good condition. [*Note: These pavements were reconstructed or sealcoated in 1996 and are now rated "excellent" with a 12,500 pound single-wheel gear weight bearing capacity*].
7. Based on its current condition, Runway 17-35 will require reconstruction with limited frost protection; the parallel taxiway will require resurfacing with future reconstruction also required; the main apron will require resurfacing with possible reconstruction. Expansion of hangar areas, aircraft parking, and automobile parking is anticipated. [*Note: In 1996, Runway 17-35, the parallel taxiway and the main apron were reconstructed; Runway 9-27 had crackfilling, sealcoating and drainage repair work done as part of the project. The reconstruction of the pavements was designed to accommodate a single wheel gear weight bearing capacity of 12,500 pounds*].
8. The existing width of Runway 17-35 (50 feet) does not meet FAA design standards for Airplane Design Group I or II operations (60 and 75 feet, respectively). [*Note: Reconstructed to 60 feet wide in 1996*].
9. The existing length of Runway 17-35 (4,500 feet) is not adequate to fully accommodate all aircraft which operate at the airport. Future forecast aircraft demands will not be adequately met with the current runway length. The existing length of Runway 9-27 (3,436 feet) is also not considered fully adequate for current and projected aircraft use.

CURRENT AIRPORT LAYOUT PLAN REPORT CONCLUSIONS (Continued)

10. The existing design aircraft for the airport, based on overall activity would be a light or medium twin-engine aircraft such as a Beechcraft Baron or Cessna 402, included in FAA Airplane Design Group (ADG) I and Approach Category B. The future design aircraft is the Cessna Citation II business jet. The airport currently accommodates regular Citation II and other ADG II operations, but the activity is slightly less than the 500 itinerant annual operations threshold recognized by the FAA. Based on a forecast increase in ADG II activity during the planning period, use of ADG I design standards is appropriate for existing and intermediate improvements, with ADG II standards recommended for ultimate development. The typical light or medium twin-engine aircraft is included in Airplane Design Group I and Approach Category B. **Therefore, airport reference code (ARC) "B-I" is appropriate for use at John Day State Airport, with B-II (Cessna Citation II) identified as the ultimate ARC.** Due to the crosswind coverage provided on the primary runway, the selected design standards should be applied to both runways.
11. The absence of an instrument approach procedure has previously been identified as a significant limitation in airport capabilities.
12. The existing airport access is considered to be generally adequate for airport needs; however, interest in providing airport access via the West Bench area does exist. Improving the existing access roadway from around the south end of Runway 17-35, along the east side of the airport appears to be feasible, however, the primary consideration should be the ability to protect the integrity of all current and future airfield facilities, particularly aircraft approach surfaces.
13. The limited availability of water at the airport for fire protection is not adequate for existing and projected demand. Providing an improved water system or storage capabilities should be considered.
14. One of the primary safety concerns at John Day State Airport is frequency of animal incursions on the runways and taxiways. Providing airport security fencing which is capable of significantly reducing this threat would be an important improvement at the airport. [*Note: Perimeter fencing installed in 1996*]

CURRENT AIRPORT LAYOUT PLAN REPORT RECOMMENDATIONS

The recommendations of previous planning efforts were examined to revalidate or eliminate recommendations as appropriate, based on current considerations and design standards.

Many of the previously-recommended improvements have been conducted or have been revalidated or slightly modified through the current planning process. The prior recommendation to install a nondirectional beacon (NDB) has become obsolete due to the development of the global positioning system (GPS). In addition, the recommendation to provide a VASI on Runway 34 is not maintained due to the mountainous terrain located immediately south of the runway. Updated recommendations include the following:

1. Reconstruct, widen, and extend Runway 17-35 to 5,000 by 60 feet. A 500-foot extension should be added on the Runway 17 end. An additional 400-foot extension reserve should be identified at the Runway 34 end to protect potential demands beyond the current planning period. Parallel taxiway extensions with aircraft turnarounds; standard runway safety areas; and upgraded (MIRL) runway lighting should be included with the runway extension project. An ultimate runway width of 75 feet is recommended as a long term improvement to meet ADG II standards. [*Note: Runway 17-35 reconstructed at 4,500 by 60 feet with MIRL in 1996*].
2. Resurface/reconstruct Runway 17-35 parallel taxiway with aircraft run-up areas at each end; provide upgraded reflective edge markers. The existing runway-taxiway separation of 250 feet would be reduced to 240 feet and the taxiway would be widened from 30 to 35 feet to meet ADG II standards. Another recommended long-term project is the installation of medium intensity taxiway edge lighting (MITL). [*Note: Parallel Taxiway reconstructed at 30 feet width with holding areas in 1996*].
3. Conduct pavement maintenance (crack filling, sealcoat, and drainage repair) on Runway 9-27 immediately in order to maintain safe conditions and maximize useful life. Implement a regular maintenance program on all pavements which are being rehabilitated or reconstructed. [*Note: Runway 9-27 crackfilled, sealcoated with drainage repair completed in 1996*].
4. Construct access taxiway and partial-length parallel taxiway on the north side of Runway 9-27. If constructed in phases, the first priority should be to provide an access taxiway which extends from the Runway 17-35 taxiway system to the mid-point of Runway 9-27; the second phase would be the parallel taxiway section extending to the end of Runway 27. Reflective edge markers should be added to the taxiways. The taxiway should be designed based on ADG II standards, with a runway-taxiway separation of 240 feet. Depending on the timing of the project, the taxiway may be constructed at a width of 30 feet and later widened to 35 feet to meet ADG II standards. The parallel taxiway should be extended in conjunction with any future runway extension.

CURRENT AIRPORT LAYOUT PLAN REPORT RECOMMENDATIONS (Continued)

5. A pavement weight bearing capacity of 12,500 pounds (single wheel) is adequate to accommodate the design aircraft and most aircraft which operate at the airport. However, a limited amount of larger aircraft with operating weights exceeding 25,000 pounds also use the airport. Although this level of activity is not sufficient to meet the FAA's criteria for selecting the critical aircraft, it may be appropriate to consider the potential affects of these aircraft operations on future pavement designs. A cost-benefit analysis should be conducted to determine at what level activity by larger aircraft will create excessive wear on pavements with a 12,500 pound design capacity. Based on the findings of the analysis it may be appropriate to consider an incremental upgrade in pavement weight bearing capacity as a preventative measure to ensure long-term protection of the new surface.
6. Realign and upgrade existing West Bench Roadway along southeastern and southern portion of the airport. Existing terminal area vehicle parking areas should be expanded or reconfigured in conjunction with roadway realignment. The realigned roadway will provide physical separation from existing Forest Service facilities, including the helicopter landing areas.
7. Reconstruct, reconfigure, and expand the Main Apron to accommodate relocated fuel storage and terminal building facilities and expanded aircraft parking. The complete reconfiguration of the Main Apron is contingent upon the realignment of the West Bench Access Road. Although expansion area is limited, the reconfiguration will permit optimal utilization of available space and improved aircraft circulation on the apron. [*Note: Main Apron reconstructed and expanded in 1996*].
8. The entire area located along the east side of Runway 17-35, from the end of the current hangar development, to the future end of Runway 17, should be reserved for general aviation parking and hangar development.
9. Construct aircraft hangar access taxiways from the Runway 17-35 parallel taxiway to serve the North GA area (300 x 20 feet). Provide lease areas for T-hangars and conventional hangars.
10. Construct aircraft aprons in phases to accommodate aircraft parking requirements and to serve conventional hangar development.
11. Provide airport security fencing around all active airfield areas. If added in phases, the highest priority would be to fence along the east and west sides, and the ends of Runway 17-35. The second phase would extend the fencing beyond the west end and along each side of Runway 9-27. The Oregon Fish and Wildlife Department has designed a fence which provides a more effective barrier for range animals. This design would be appropriate for use at John Day. [*Note: 76" game fencing was added to the airport perimeter as part of the 1996 improvements*].

CURRENT AIRPORT LAYOUT PLAN REPORT RECOMMENDATIONS (Continued)

12. Reserve airport property south of the Main Apron for government forestry-related aviation development. Expansion of airside and landside areas would be determined by specific tenant requirements.
13. Protect land area required to establish global positioning system (GPS) or other nonprecision straight-in instrument approaches on Runways 17 and 9. Relocated building restriction line (BRL) and aircraft parking lines will be required along the runways to protect the expanded FAR Part 77 Surfaces from structural and aircraft penetrations.
14. Establish an airport overlay zone which coincide with the future approach surfaces and upgraded FAR Part 77 surfaces. The airport overlay zoning should conform with guidelines provided by the Oregon Department of Transportation - Aeronautics Section, regarding airport land use compatibility planning.
15. Safeguard the Runway Protection Zones by acquiring aviation easements for portions of the existing and future RPZs located outside airport property, not presently controlled by the sponsor.
16. Replace VASI unit on Runway 17 at the end of its useful life with a precision approach path indicator (PAPI). Adding PAPI units on Runways 9 and 27 is also recommended, although with a lower priority.
17. Add runway end identifier lights (REIL) on Runway 9.
18. Establish aviation development reserves on the northwest section of the airport for long-term development demands; acquire approximately 15 acres of privately-owned property located along the northwestern edge of the airport. An access roadway reserve should also be identified on the Airport Layout Plan to provide access to the west side of the airport. The roadway alignment needs to be compatible with the ultimate configuration of Runway 17-35, including the extended runway safety area and object free areas.
19. The Sponsor should adopt the Airport Layout Plan document and drawings in a timely manner. The Airport Layout Plan Report should be submitted by the Sponsor to Grant County for incorporation in the County Comprehensive Plan. The Sponsor should also coordinate proposed changes in existing airport overlay zoning with the County.
20. Request funding assistance under FAA and other federal, state or local funding programs for all eligible capital improvements.
21. Initiate the development of the recommended improvements in a timely manner.

Airport Layout Plan Report

for

**John Day State Airport
John Day, Oregon**

prepared for the

**Oregon Department of Transportation
Aeronautics**

and

Grant County Airport Commission

Chapter Three **INVENTORY and FORECASTS**

INTRODUCTION

A considerable amount of data are developed, organized, and tabulated in the preparation of an airport layout plan report. The purpose of this section of the report is to describe these data to establish the past and existing roles of the airport and to serve as a foundation for determining the future role of the airport. Historical data from the **Airport Layout Plan Report** (CH2M Hill, 1979) served as a primary reference in this evaluation. Historical forecasts of aviation activity have also been reviewed and updated, as required. Area socioeconomic activity has been reviewed, and the existing airfield facilities have been evaluated. *As noted earlier, the numerical magnetic designation of the primary runway has recently been changed from 16-34 (160-340 degrees) to 17-35. References to the runway have been revised.*

AIRPORT LOCATION

LOCALE

John Day State Airport occupies approximately 335 acres (Airport Exhibit "A" drawing, August, 1981) and is owned by the State of Oregon Department of Transportation, and operated jointly by ODOT Aeronautics and Grant County, through a formal agreement. Airport elevation is recorded at 3,697 feet above mean sea level (MSL). The Airport Reference Point coordinates are Latitude 44°24'24"N, and Longitude 123°11'90"W. Vehicle access to the airport is provided from a roadway connecting to State Highway 395, south of the center of John Day. The roadway has a series of switchbacks which are required to offset a significant elevation gain from the highway to the airport. The location of the airport and community are shown in **Figure 3-1**.

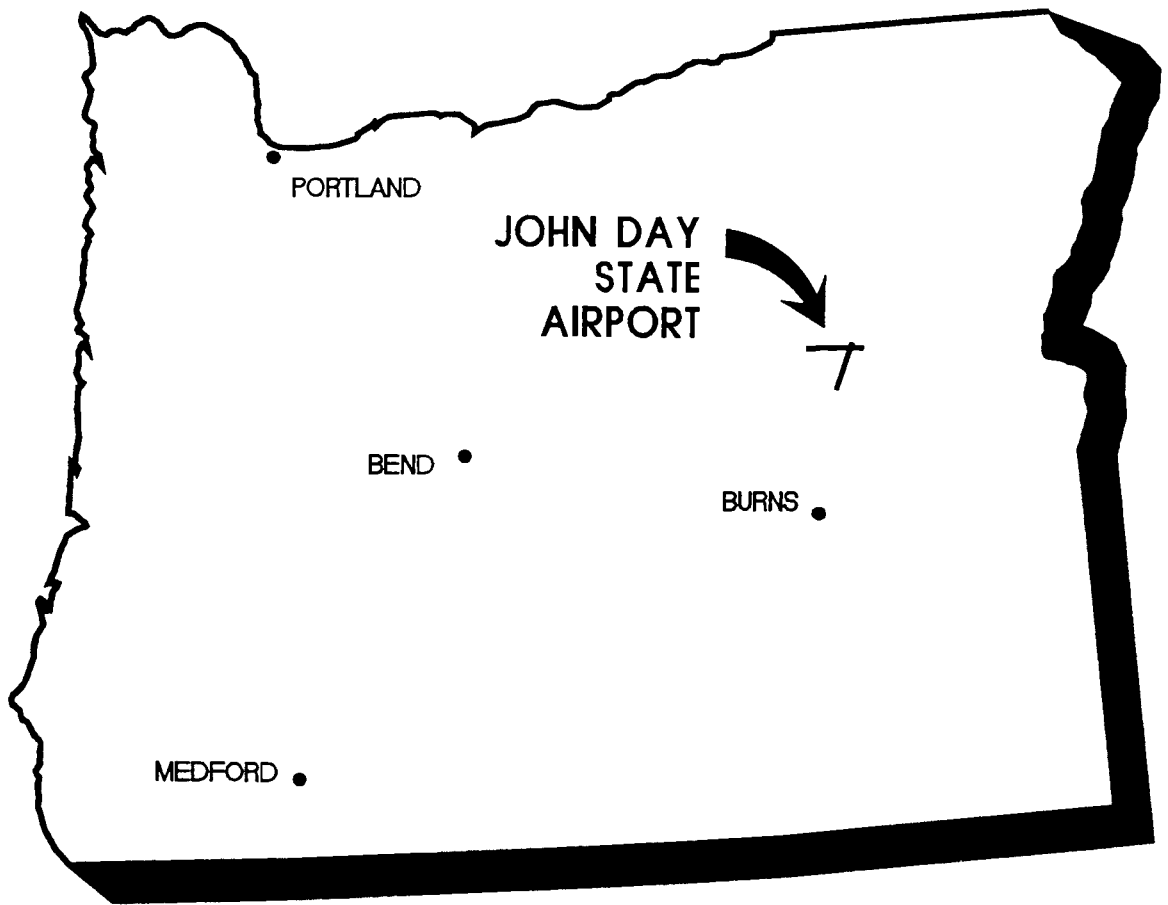

LOCATION MAP
JOHN DAY STATE AIRPORT
JOHN DAY, OREGON

FIGURE 3-1

John Day is located in central Grant County, which consists of 4,528 square miles of land area. The county seat, Canyon City, is located approximately one mile south of John Day on Highway 395. The airport is located 1.5 miles southwest of John Day. John Day is located approximately 118 miles east of Prineville on Highway 26; Burns is located approximately 70 miles to the south on Highway 398; Pendleton is located approximately 130 miles to the north on Highway 395; and Ontario is located approximately 135 miles to the east-southeast on Highway 26. Several public-use airports are located within a 100 nautical mile radius of John Day including Prineville, Burns, La Grande, Baker City, Ontario, and Condon State.

Grant County is one of Oregon's larger counties, with more than 60 percent of its land area in public ownership. The county's economic base is heavily dependent on the harvesting and processing of wood products. The county also supports agriculture, livestock, and recreational activities. The area has a number of points of interest including the John Day Fossil Beds National Monument, mining museums, and the Strawberry Mountain and North Fork John Day River wilderness areas.

AREA TOPOGRAPHY

John Day is located in the Central Mountains portion of the Columbia Intermontane region, often referred to as the Columbia Plateau. The region is characterized by mountainous terrain, forest lands and range lands. The community of John Day is located in a valley surrounded by mountainous terrain, including the Blue Mountain range located to the north. The Malheur, Ochoco, and Umatilla National Forests surround John Day in all directions.

The terrain surrounding the airport is very complex and includes such features as Strawberry Mountain (14 nautical miles southeast), which reaches 9,080 feet; an unnamed peak (6 nm southeast), reaches 8,020 feet; Black Butte (11 nm northwest), reaches 6,235 feet; and numerous peaks ranging from 6,000 to 7,500 feet are located within ten to fifteen miles of the airport in all directions. The National Oceanic Service Klamath Falls Sectional Chart identifies maximum elevation figures (MEF) ranging from 6,600 to 9,400 feet in the quadrants surrounding John Day. These elevations are used by pilots as a general indication of the highest terrain located within a quadrangle.

CLIMATE

Weather conditions play an important role in the planning and development of an airport. Temperature and wind direction directly affect runway alignment, length, and other requirements. Cloud coverage and precipitation affect visibility and are a primary determinant for navigational aids

and lighting. The region is characterized by low precipitation, large temperature ranges between winter and summer, and fewer cloudy days than the western part of the state. Prevailing winds appear to be primarily east-west in direction.

AIRPORT HISTORY

Historical records indicate that the existing airport site has been in aeronautical use as far back as the 1920s. Another site located along the John Day River, accommodated a private airstrip for several years. The present airport site was developed into a public facility in the early 1960s, following the acquisition of property by the City of John Day, which was then deeded to the Oregon State Board of Aeronautics. The U.S. Forest Service has a long-standing presence at the airport, and actually graded the airport's initial crosswind runway for use by their aircraft. Airport improvements have continued through the years, including construction of a paved crosswind runway in the early 1980s and improvements in aircraft parking and hangar areas. The State of Oregon Department of Transportation - Aeronautics entered into a joint maintenance-operation agreement with Grant County several years ago.

SOCIOECONOMIC CONDITIONS

Grant County's population in the 1990 U.S. Census was estimated at 7,853, down 4.3 percent since the 1980 census. The decline in population is considered to be primarily the result of periodic out-migration of unemployed wood products workers in the area. Population data updated in 1992 indicates a Grant County population of 8,000, up slightly from the 1990 census. The median age of population within the county is 36.4, slightly higher than the statewide median of 34.5. Current Portland State University (PSU) population projections for Grant County reflect average growth of 0.46 percent annually through 2010.

The wood products industry remains the largest segment of the county's economy, although the area also supports agricultural (livestock and crops) and a growing recreational/tourism industry. A number of mineral deposits (Gold, Silver, and Copper) have been identified within the county. The forest lands within the county consist primarily of Ponderosa Pine, Larch, and Firs-Engelman Spruce.

As is the case with many counties which are heavily dependent on wood products-related employment, Grant County has periodically experienced very high levels of unemployment, with percentages ranging from around 8 percent in the late 1970s to more than 20 percent in 1982. Current unemployment rates remain relatively high, although total wage and salary employment

reflects a slow steady gain since 1982 which has resulted in an increase of nearly 1,000 jobs.

According to Oregon Department of Employment data, the leading employment industries (1992 data) in Northeast Oregon (Grant, Baker, Union, Wallowa County area) include:

<u>Industry</u>	<u>Number of Jobs</u>
1. Local, State and Federal Government	5,940
2. Wholesale and Retail Trade	4,220
3. Services	3,130
4. Lumber and Wood Products	2,620
5. Transportation, Communications, Utilities	1,180
6. Finance, Insurance, Real Estate	670
7. Other Manufacturing	640
8. Construction and Mining	500

EXISTING FACILITIES

Airfield facilities directly relate to the arrival or departure of aircraft and are termed "airside." Airside facilities include runways, taxiways, airfield lighting, and navigational aids. "Landside" facilities are those interfacing with or supporting airfield functions, including aircraft parking areas, hangars and aircraft storage areas, airport administrative and maintenance buildings, airport roadways and vehicle parking areas. **Table 3-1** provides a summary of existing facilities. **Figure 3-2** depicts existing conditions at the airport.

AIRSIDE FACILITIES

John Day State Airport has a two paved runways. The primary runway, designated as 17-35, is 4,500 feet long and 50 feet wide with an asphalt surface and basic visual marking. The effective gradient of Runway 17-35 is 0.45 percent. The runway is served by a full-length (30-foot wide) parallel taxiway. The runway has low-intensity runway edge lighting and is equipped with a visual approach slope indicator (VASI) on Runway 17.

The secondary runway, designated as 9-27, is 3,436 feet long and 60 feet wide with an asphalt surface and basic visual marking. The effective gradient of Runway 9-27 is approximately 1.34 percent. The runway has low-intensity runway edge lighting but is not equipped with visual guidance indicators (VGI). Runway 9-27 is not served with a parallel taxiway, but has an aircraft turnaround located at the Runway 9 end. The Runway 27 threshold is accessed by a connecting taxiway which extends from the Runway 17-35 parallel taxiway.

The most recent FAA 5010 Airport Record Form lists pavement strength for Runway 17-35 at 8,000 pounds for aircraft with single-wheel (SW) landing gear and Runway 9-27 at 12,000 pounds SW. The surface of Runway 17-35 has experienced a substantial amount of reflective cracking in recent years. A maintenance program, which has consisted of vegetation control and cracksealing has prolonged the useful life of the pavement, but the runway is now in need of reconstruction and resurfacing.

A pavement evaluation conducted in April, 1989 listed pavement condition indexes (PCI) ranging from 67 to 74 on Runway 17-35 and 86 to 96 on Runway 9-27; 50 to 76 on the Runway 17-35 parallel taxiway; and 24 to 78 on the main apron. The evaluation identified the Runway 17-35, parallel taxiway, and the main apron pavements as being the original surfaces, with four crackfilling projects having been conducted and one application of reclamite on the runway since original construction. The 1989 evaluation indicated that the main runway was in "very good condition," with cracking (.75 to 1.5 inch) being the major problem; the parallel taxiway was rated "good" also

John Day State Airport - Ogilvie Field

Airport Layout Plan

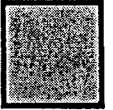

Airport Facilities

Owner:	Oregon Department of Transportation; operating/maintenance agreement with Grant County
Community:	John Day, Canyon City, Prairie City, Mount Vernon, other outlying communities
Runways:	Two Paved Runways: Runway 17-35: 4,500 x 50 feet; Asphalt Surface Runway 9-27: 3,436 x 60 feet; Asphalt Surface
Taxiways:	Runway 17-35 Full-Length Parallel Taxiway with Four Exits Access Taxiway to Runway 27 Threshold
Aprons:	Main Apron; General Aviation Tiedown; Forest Service Apron
Lighting:	Low-Intensity Runway Edge Lighting (both runways); VASI - Runway 17.
Nav aids:	None.
Helicopter:	Itinerant Helicopter Parking on Main Apron; Forest Service Helipads (3)
Fuel Storage:	Two 12,000 gallon underground tanks (one each AVGAS and Jet Fuel)
Airport Bldgs.:	11 aircraft hangars (individual and multi-unit); airport terminal; Forest Service buildings

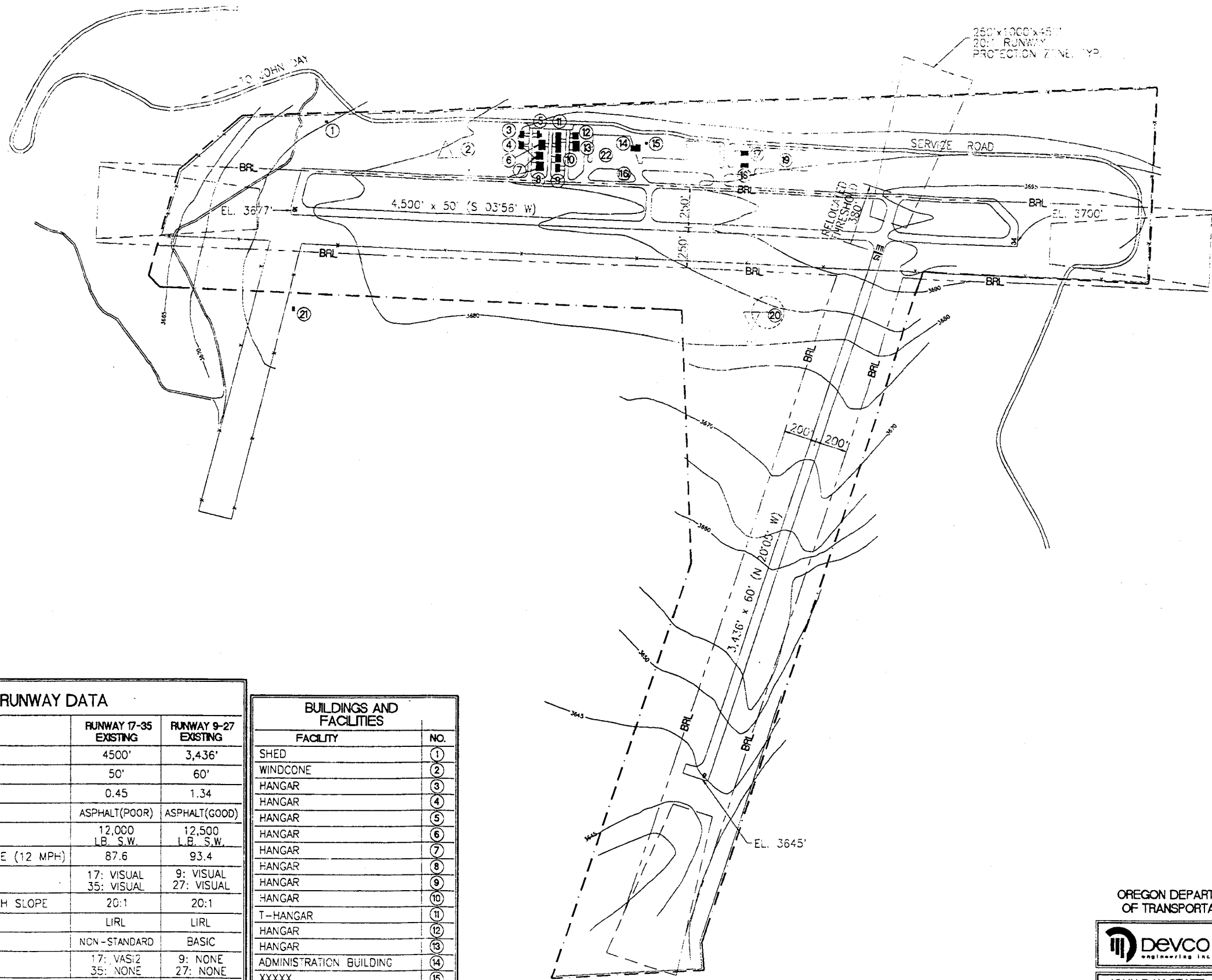

250' x 1000' x 45'
20' RUNWAY
PROTECTION ZONE, 17P.

AIRPORT DATA

	EXISTING
AIRPORT ELEVATION (MSL)	3,697'
AIRPORT REFERENCE POINT (ARP)	44°24'15" N 118°57'45" W
AIRPORT MAGNETIC VARIATION	19°24' E (1975)
AIRPORT REFERENCE CODE	B-1
NPIAS ROLE	BASIC UTILITY
AIRPORT CLASSIFICATION	GENERAL AVIATION
MEAN MAX. TEMP. HOTTEST MONTH	90.3° F
NAVIGATIONAL AIDS	BEACON, WINDCONE, LIGHTED WINDCONE, SEG. CIRCLE
TAXIWAY LIGHTING	NONE

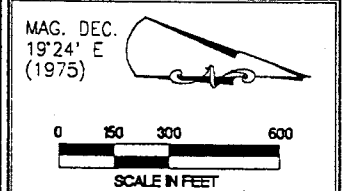

RUNWAY DATA

	RUNWAY 17-35 EXISTING	RUNWAY 9-27 EXISTING
RUNWAY LENGTH (FT.)	4500'	3,436'
RUNWAY WIDTH (FT.)	50'	60'
EFFECTIVE GRADIENT (%)	0.45	1.34
PAVEMENT TYPE	ASPHALT(POOR)	ASPHALT(GOOD)
PAVEMENT STRENGTH	12,000 LB. S.W.	12,500 LB. S.W.
PERCENT WIND COVERAGE (12 MPH)	87.6	93.4
FAR PART 77 (UTILITY)	17: VISUAL 35: VISUAL	9: VISUAL 27: VISUAL
RECOMMENDED APPROACH SLOPE	20:1	20:1
RUNWAY LIGHTING	LIRL	LIRL
RUNWAY MARKING	NON-STANDARD	BASIC
LANDING AIDS	17: VASI 35: NONE	9: NONE 27: NONE
OBJECT FREE AREA	WIDTH: 400' LENGTH BEYOND RUNWAY END: 240'	WIDTH: 400' LENGTH BEYOND RUNWAY END: 240'
SAFETY AREA DIM.	WIDTH: 120' LENGTH BEYOND RUNWAY END: 240'	WIDTH: 120' LENGTH BEYOND RUNWAY END: 240'
CRITICAL AIRCRAFT	CESSNA 402	CESSNA 402
DECLARED DISTANCES	LDA: 4,500' TORA: 4,500'	LDA: 3,436' TORA: 3,436'

BUILDINGS AND FACILITIES

FACILITY	NO.
SHED	1
WINDCONE	2
HANGAR	3
HANGAR	4
HANGAR	5
HANGAR	6
HANGAR	7
HANGAR	8
HANGAR	9
HANGAR	10
T-HANGAR	11
HANGAR	12
HANGAR	13
ADMINISTRATION BUILDING	14
XXXXX	15
HELICOPTER FUELING PAD	16
U.S. FOREST SERVICE BLDG.	17
U.S. FOREST SERVICE BLDG.	18
U.S. FOREST SERVICE APRON	19
SEGMENTED CIRCLE AND LIGHTED WINDCONE	20
XXXXX	21
FUEL ISLAND	22

LEGEND

FACILITY	EXISTING SYMBOL
FACILITIES	---
BUILDINGS	■
AIRPORT PROPERTY LINE	- - - -
BLDG. RESTRICTION LINE	- - - -
RUNWAY SAFETY AREA	- - - -
RWY OBJECT FREE AREA	- - - -
THRESHOLD LIGHTS	— — —
MEDIUM INTENSITY RUNWAY LIGHTING (MIRL)	•
TAXIWAY REFLECTORS	•
AIRPORT REF. POINT	⊙
VASI	≡
FENCE	* * * *
WINDCONE	>
SEGMENTED CIRCLE AND LIGHTED WINDCONE	⊙
TOPOGRAPHIC CONTOURS CONTOUR INTERVAL = X'	---X---
TREES AND VEGETATION	☁

OREGON DEPARTMENT OF TRANSPORTATION



JOHN DAY STATE AIRPORT
JOHN DAY, OREGON
EXISTING FACILITIES

Job No. 94-016 ISSUED-X

FIGURE: **3-2**

The preparation of this document was financed in part by a planning grant from the FAA as provided under Section 505 of the Airport and Airway Improvement Act of 1982. This document does not necessarily reflect the views of the FAA.

with conditions similar to the main runway. The evaluation recommended a short term slurry seal and long term overlay for Runway 17-35. Runway 9-27 was rated "excellent" with minor cracking visible and some raveling. A fog coat was recommended for Runway 9-27 in the next two to three years. The main apron was rated "good." Reconstruction and overlay of the apron was recommended in the short term.

Updated pavement evaluations conducted in 1994 indicate that several of the airport's pavement surfaces have continued to deteriorated with age and use. Runway 17-35 had a PCI rating of 54 ("Fair"); the parallel taxiway and main apron had ratings of 44 and 46 ("Fair"); the forestry apron and taxiway connections were rated 100 ("Excellent"); Runway 9-27 was rated 90 and 98 ("Excellent"); and the hangar access taxilanes were rated between 74 and 80 ("Very Good"). As noted earlier, both runways, the parallel taxiway, and the main apron each had pavement improvements made in 1996.

Recent visual inspections indicate that the cracking problems remain the primary problem, although the pavement surfaces on the main apron, parallel taxiway, and Runway 17-35 have continued to deteriorate. Runway 9-27 continues to be in good condition, with only minor cracking visible.

Helicopter Facilities

Helicopter activity at John Day consists primarily of forestry-related operations and itinerant activity. The Forest Service has three designated helipads located at the southern end of their facility. Itinerant helicopter operations utilize the runway-taxiway system for approach and departure, hover-taxiing to the main apron area for parking and fueling.

LANDSIDE FACILITIES

The airport has a main aircraft apron, which is approximately 200 feet by 200 feet with an asphalt surface. The main apron accommodates limited tie-downs for transient and based light aircraft and parking for larger multi-engine, turboprop, and business jet aircraft; and itinerant helicopter parking. A small section of paved area located directly in front of the airport operations building is also used for aircraft parking. The aircraft fueling area is located at the outer edge of the main apron. Access to the apron is provided with two connecting taxiways to the Runway 17-35 parallel taxiway; a small taxilane loop is located at the north end of the apron to facilitate aircraft movement on the main apron.

A second aircraft parking area (approximately 70 feet by 250 feet) is connected to the south edge

of the main apron. This area has six aircraft tiedowns located immediately east of a taxilane which connects with Forest Service aircraft apron areas.

A third aircraft apron is located south of the main apron, connected by the narrow strip of pavement described above. The apron (approximately 70 feet by 250 feet) accommodates primarily forestry-related aircraft activity. The apron has a separate connecting taxiway leading to the parallel taxiway. The U.S. Forest Service maintains facilities on the airport which include three helipads, two main operations buildings, fire retardant tanks/aircraft loading equipment, etc.

The airport currently has 11 aircraft hangars located north of the main apron. Two paved taxilanes (280 by 20 feet) provide access to the hangar rows from the parallel taxiway. Vehicle access to the hangar area is provided by a gate, which is connected to the airport access road.

An airport operations building is located near the back of the main apron. The facility (approximately 1,500 square feet) has a restroom, a meeting room, kitchen, office areas, and lounge for airport users.

AIRPORT SUPPORT FACILITIES

Aircraft fuel (AVGAS 100LL and Jet Fuel) is available through the airport operations office. The airport has two underground fuel storage tanks (12,000 gallon capacity each) for AVGAS and Jet Fuel. The fuel tanks are located near the western edge of the apron.

48-inch high (four-strand) wire fencing is located along portions of the airport boundary and between the airport access roadway and the hangar area. Water service to the airport limited to a single 1 to 2 inch line which extends up the hill from a small residential reservoir located east of the airport. According to airport users, the system does not provide adequate water flow rates for current demand. The airport operations building and the Forest Service facilities have separate septic systems. The airport has a designated automobile parking area located near the east end of the apron, along the access road; the Forest Service also has a separate auto parking area.

Electrical power to airport facilities is provided by an overhead line which runs along the east side of the airport access roadway; overhead lines run from the main line across the access road to the structures.

AIRPORT LIGHTING/VISUAL NAVAIDS

Both runways are equipped with low-intensity runway edge lighting (LIRL) and standard threshold lights. The runway lights are pilot-activated on the common traffic advisory frequency (CTAF) 122.8 MHZ. Runway 17 is has a visual approach slope indicator (VASI). The airport has received, but not yet installed, a set of runway end identifier lights (REIL) for Runway 17.

The airport rotating beacon is located directly north of the main apron, mounted on the roof a large hangar. The parallel taxiway for Runway 17-35 is equipped with upright edge reflectors only. A single flood light, located behind the airport operations building, provides lighting on the main apron; a small flood light is also mounted above the fuel pumps.

The airport has one segmented circles with wind cones located on the east and west side of Runway 17-35, north of Runway 9-27. A third wind cone is mounted on top of the fuel station at the main apron.

AIRSPACE AND NAVIGATIONAL AIDS

John Day State Airport operates under visual flight rules (VFR) conditions and is not equipped with electronic navigational aids. The airspace surrounding the airport is relatively uncomplicated.

A review of the current Klamath Falls and Seattle Sectional Charts identifies primarily mountainous terrain in the vicinity of John Day State Airport. A single tower is identified approximately 14 nautical miles southwest of the airport with a top elevation of 5,066 feet MSL (299 feet above ground level). Two power transmission lines are located within one mile of the airport on its east and north sides; however, the elevation of the airport several hundred feet above the community, significantly reduces the impact of potential nearby obstructions.

A standard traffic pattern is used for Runway 17-35; a right traffic pattern is established for Runway 9, with left traffic for Runway 27. A traffic pattern altitude of 1,000 feet above ground level (4,697 MSL) is used.

The high terrain surrounding the airport results in instrument (Victor) airways passing over the airport with relatively high minimum enroute or obstruction altitudes (MEA or MOA). Victor 500 passes directly north of the airport; Victor 357 and 497 are located east and west of the airport. The airways do not affect local airspace due to the high minimum enroute altitudes.

John Day State Airport is located approximately 48 nautical miles from Wildhorse VOR/DME, on

the 340 degree radial (113.8 MHZ). The nearest public-use airport is Burns Municipal Airport, located 48 nautical miles to the south. The Kimberly VORTAC (115.6 MHZ) is located 35.3 nautical miles northwest of the airport on the 092 degree radial.

AIRPORT SERVICE AREA

The airport service area, or airport trade area, as it is commonly known, refers to the area surrounding an airport which is directly affected by activities at that airport. Air trade areas are determined primarily by the facilities provided at a particular airport and the number of airports in a particular area. Typically, a 30-minute surface travel time is used to approximate the boundaries of an air trade area. However, the presence (or absence) of other airports in a large area can directly affect airport use. The John Day State Airport service area extends roughly from west of Dayville to east of Austin (on or near Highway 26), north toward Dale on Highway 395, and south beyond Seneca on Highway 395. Although there are a number of small airstrips located within this area, the facilities available at John Day State Airport (i.e fuel, runway length, etc.) are only available at larger facilities such as Prineville, Burns, Baker, and Pendleton. The continued use of the airport for business and medevac flights is particularly dependent on maintaining quality facilities.

The 1989 Oregon Aviation System Plan indicated that Grant County had 37 registered pilots in 1989, down from 38 in 1988. The OASP indicated that there were 41 FAA-registered aircraft in Grant County in 1989. Updated registration data maintained by ODOT Aeronautics, indicates that Grant County had 46 registered pilots and 47 registered aircraft in 1994.

AVIATION ACTIVITY

BASED AIRCRAFT

There are currently 24 based aircraft at John Day, being primarily single-engine, fixed-wing aircraft. As noted earlier, the airport typically experiences a surge in based aircraft during the summer fire season when 5 to 7 additional fixed wing and helicopters are located at the airport. **Table 3-2** shows historical data on based aircraft at John Day and in Grant County.

**Table 3-2
TOTAL BASED AIRCRAFT
John Day State AIRPORT**

<u>Year</u>	<u>Single Engine</u>	<u>Multi Engine</u>	<u>Rotor</u>	<u>Other</u>	<u>Total</u>
1994	23	1	0	0	24
1988	19	1	1	3	24
1987	-	-	-	-	26
1986	-	-	-	-	29
1985	-	-	-	-	28
1984	-	-	-	-	27
1983	-	-	-	-	32
1979	-	-	-	-	25
1978	20	3	0	1	24

Source: Airport Records; Oregon Aviation System Plan Data; 1979 Airport Layout Plan; FAA Form 5010-A.

Note: Breakdown by aircraft type not available for all years in OASP Data

GENERAL AVIATION ACTIVITY

The Oregon Aviation System Plan (OASP) (1989 Inventory/Forecasts) provides historical estimates of aircraft operations for the airport. This data was also supplemented by an acoustical counting program conducted by Oregon Department of Transportation - Aeronautics in 1992-1993. However, the acoustical data did not correlate with on-field activity records maintained by local airport management personnel. The on-site recording is considered reasonably accurate with the potential of underestimating actual traffic (5 to 10 percent) due to after hours activity and periods where the individual responsible for recording data is occupied with fueling aircraft, etc. Despite these inherent data collection limitations, the on-site activity records exceeded the acoustical measurements by approximately 50 percent. As a result, the acoustical data was not considered sufficiently reliable for purposes of estimating base year activity for generating forecasts. Therefore, airport activity records were used as the primary source for evaluating airport traffic levels. Historical aviation activity is shown in Table 3-3. Forecasts for aviation activity are found in the 1984 and 1989 System Plans and also in the John Day Airport Layout Plan Report (1979). A comparison of these forecasts is presented in Table 3-4.

In order to evaluate future airport activity based on current conditions, it is necessary to review existing forecasts and consider unique factors which may directly affect a particular airport. The existing aviation activity forecasts for John Day State Airport are of limited value considering that the ALP forecasts are dated and were based on conditions considerably different than currently exist in the area. The OASP forecasts are limited by their use of broad-based statewide or regional growth assumptions, but provide a reasonable baseline indication of future activity. .

Existing system plan forecasts project a moderate growth rate in the range of 2.31 percent annually, with a gradual increase in based aircraft through the year 2000 (27 aircraft). The 1979 ALP Report forecasts identified considerably higher levels of based aircraft and aircraft operations than currently exist. Although the projected growth rates were not excessive, the 1979 ALP forecasts failed to anticipate the drastic decline in the local wood products industry that culminated in unemployment rate which exceeded 20 percent in Grant County in 1982.

With an increase in based aircraft from 24 to 28 by 1999, projections for the balance of the planning period were made utilizing an annual average growth rate of approximately 3.1 percent. Although this rate of growth is slightly higher than the statewide average, it is in part due to the airport's ability to accommodate demand for facilities within the region. It is anticipated that based aircraft would increase to approximately 46 by 2014, reflecting an overall (20 year) annual growth rate of approximately 3.3 percent. Based aircraft forecasts were developed which reflect a range of projections from 24 to 46 based aircraft by the end of the current planning period (2014). It is also noted that the number of aircraft located at the airport during the busy summer season can increase by nearly 25 percent. This trend is expected to continue during the planning period.

Recent based aircraft totals and estimates of activity indicate an average of approximately 200 operations per based aircraft annually. For forecasting purposes, a slightly more aggressive ratio of 270 operations per based aircraft was used in projecting airport activity. Although this ratio is slightly higher than that used in the most recent state aviation system plan (190 operations per based aircraft), it is considerably lower than the ratio utilized by the FAA in estimating airport activity at small general aviation airports (637 operations per based aircraft), where detailed activity data is unavailable (as described in AC 150/5300-13). The level of local activity appears to be in the 5 percent range, which is lower than is typically found, although there is no substantial amount of flight training activity at the airport. Updated forecasts of based aircraft and aircraft operations are presented in **Table 3-5** and **Figures 3-3** and **3-4**.

Table 3-3
HISTORICAL AIRPORT ACTIVITY
John Day State Airport

<u>Type of Operation</u>	<u>1989*</u>	<u>1994**</u>
Itinerant GA & Forestry-Related	3,300	5,500
Non-Scheduled Air Taxi	<u>100</u>	<u>100</u>
Total Itinerant Operations	3,400	5,600
Total Local	<u>1,400</u>	<u>300</u>
Total Annual Operations	4,800	5,900

Note: 1993 OAD Aircraft Acoustical Counting Program estimated 3,788 operations, which does not correlate with on-field activity reports.

Source: * Oregon Aviation System Plan (1989 Forecasts)

** 1994 Airport/Consultant estimates

Table 3-4
HISTORICAL AVIATION FORECASTS
John Day State Airport

<u>Year</u>	<u>1989 OASP</u>	<u>1979 ALP</u>
1978	--	10,000 ^a
1983	--	13,800
1988	--	18,600
1989	4,800 ^a	--
1995	5,700	--
1998		25,200
2005	6,200	--

Notes: a Indicates base year forecasts.

1989 OASP = Oregon Aviation System Plan, 1989 Inventory, 1990-2000 Forecasts.

1979 ALP = John Day State Airport Layout Plan Report, CH2M Hill

AIRFIELD CAPACITY

Airfield capacity is determined by the methodologies described in Federal Aviation Administration Advisory Circular 150/5060-5, **Airport Capacity and Delay**. Runway capacity at John Day is considered to be adequate through the planning period, with both the current runway configuration and the addition of a parallel taxiway on Runway 9-27. The absence of air traffic control on the airport results in only one runway being used at any moment. Therefore, for the purposes of estimating capacity, a single runway configuration is used; this would apply equally between use of Runway 17-35 and 9-27. However, since Runway 17-35 is equipped with a full-length parallel taxiway, it would yield higher hourly capacities than Runway 9-27, which does not have taxiway access to the Runway 9 end.

Theoretical hourly capacity is approximately 59 to 72 operations during visual flight rules (VFR) conditions with Runway 9-27 and approximately 80 to 93 operations with Runway 17-35. Airport estimates of runway use indicate that approximately 60 percent of fixed wing traffic occurs on Runway 17-35, with 40 percent on Runway 9-27. If these percentages are applied to the capacity calculations, a weighted hourly capacity for the airport during VFR conditions would be approximately 78 operations. It is estimated that the airport experiences instrument flight rules (IFR) conditions approximately 4 percent of the time. Without an instrument approach procedure, the airport is essentially closed during IFR periods.

The addition of a parallel taxiway on Runway 9-27 and an instrument approach procedure for the airport would increase capacity, although because the airport does not experience any significant capacity problems on an annual basis, the primary benefits would be associated with relieving congestion during peak activity periods and during poor weather conditions.

Table 3-5
CURRENT AVIATION FORECASTS
John Day State Airport

	<u>Existing</u>	<u>1999</u>	<u>2004</u>	<u>2009</u>	<u>2014</u>
<u>High Scenario</u>					
Based Aircraft	24	29	36	43	53
Annual Operations	5,900	7,800	9,700	11,600	14,300
<u>Low Scenario</u>					
Based Aircraft	24	27	30	34	38
Annual Operations	5,800	7,300	8,100	9,200	10,300
<u>Preferred (Median) Projection</u>					
Based Aircraft	24	28	33	38	46
Itinerant Operations	4,900	6,400	7,500	8,800	10,500
Local Operations	1,000	1,200	1,400	1,500	1,800
Annual Operations	5,900	7,600	8,900	10,300	12,300

Based on the forecasts of aviation activity, *design day* demand in 2014 is projected at approximately 83 operations, nearing the *hourly* capacity of Runway 17-35 with a parallel taxiway in VFR conditions.

The annual service volume (ASV) for the airport is currently estimated at 42,000 operations. The annual capacity, as expressed as ASV, represents a theoretical capacity for airfield planning purposes; however, for airports with relatively low activity levels, a comparison of a runway's hourly capacity and peak hourly demand, provides a more practical measure of potential capacity problems. The addition of the facility improvements described above, would provide modest increases in annual capacity, however, the absence of an air traffic control tower, airport surveillance radar, and an instrument landing system (ILS), in addition to higher than usual seasonal activity peaking, are the primary capacity constraints. As noted earlier, forecast demand will remain well below available capacity throughout the planning period.

Figure 3-3

Based Aircraft Forecast John Day State Airport

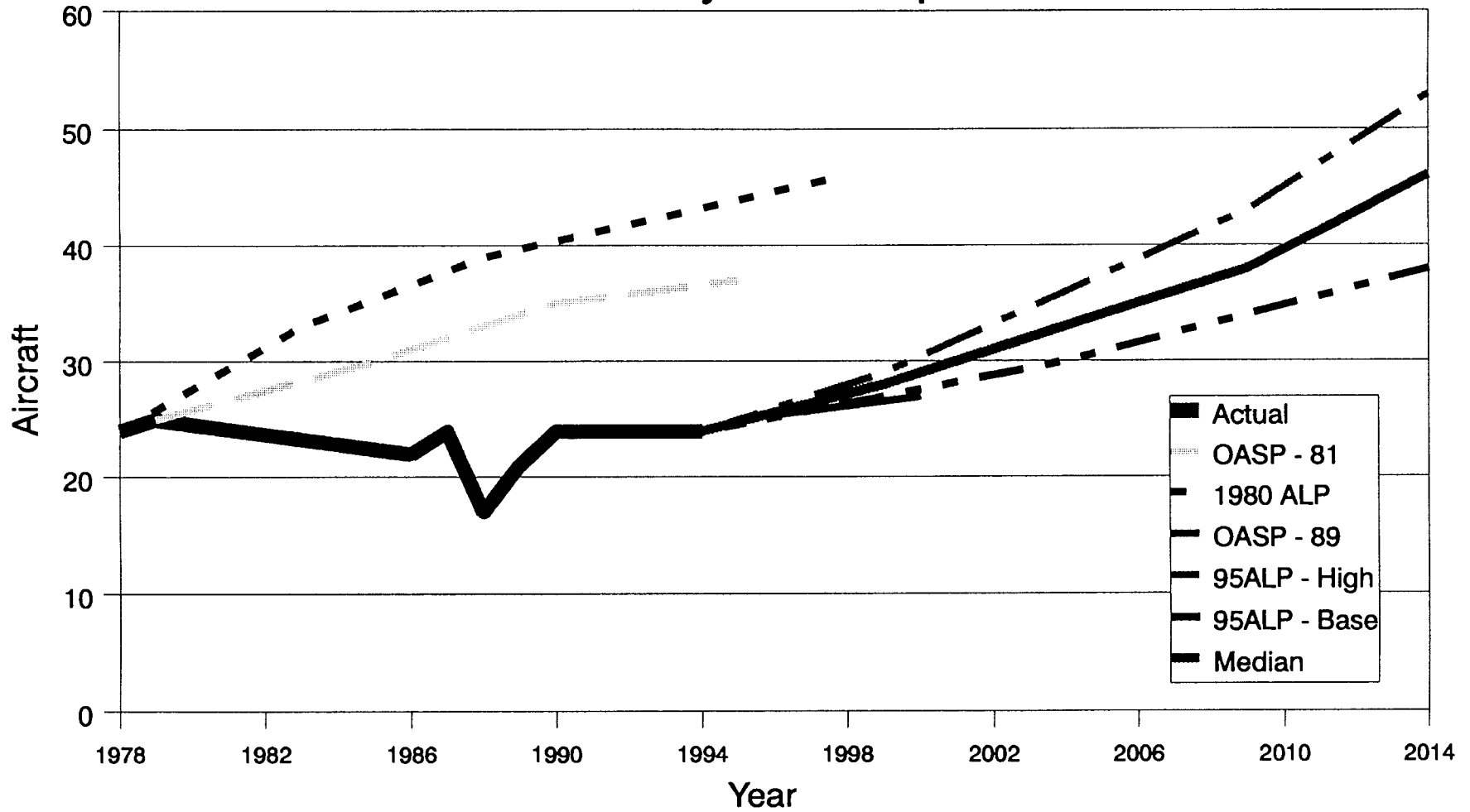
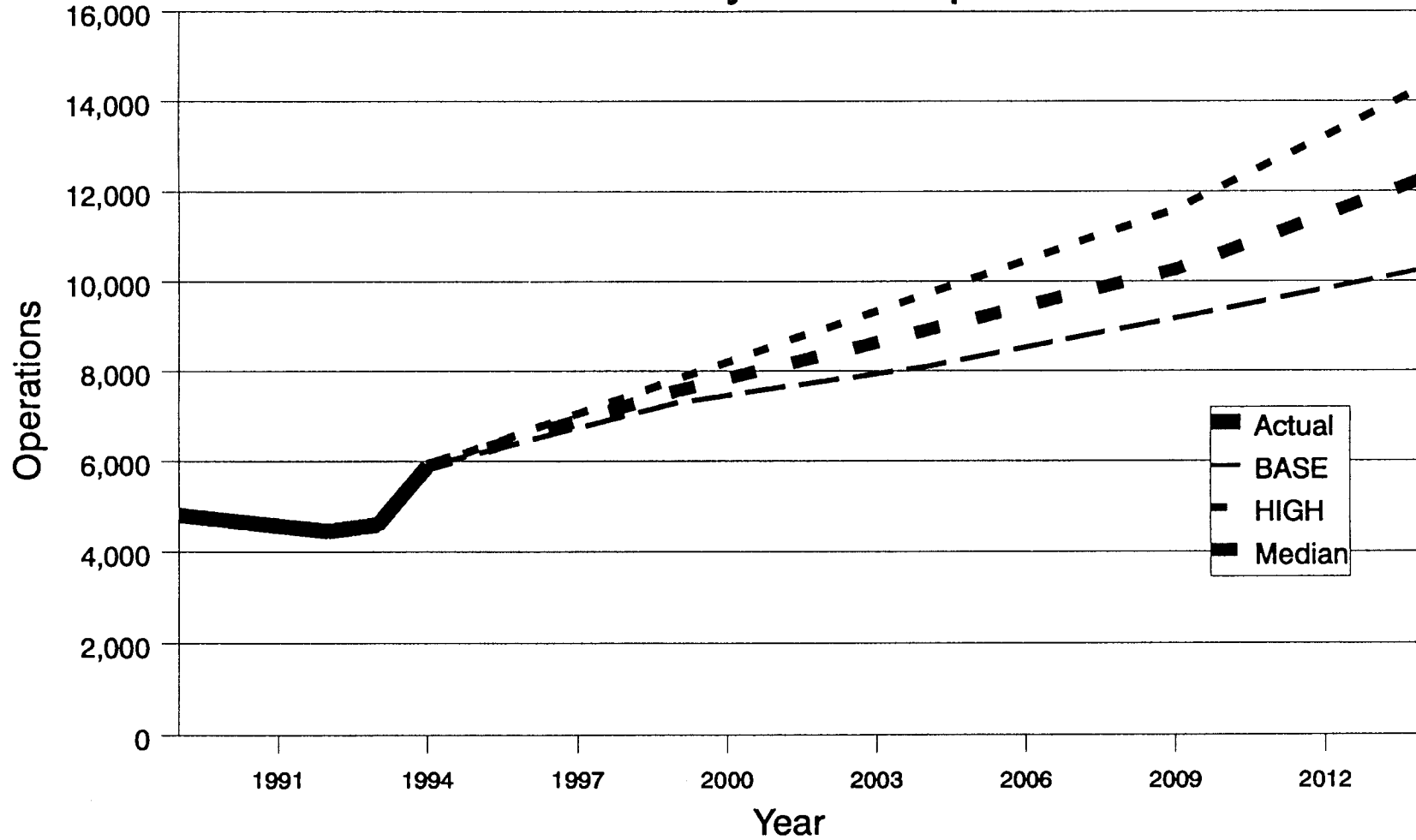

Figure 3-4

Aircraft Operations Forecast John Day State Airport



LAND-USE PLANNING AND ZONING

The airport is surrounded by relatively open land at this time. The airport is situated at the southern limit of the City of John Day urban growth boundary. Land use control and zoning in the vicinity of the airport is administered by Grant County. Adjacent properties to the airport have a variety of zoning, including Rural Residential and Light Industrial, and Rangeland designations. The Canyon City boundary (city limits) is located immediately east of the south end of the airport, including the approach for Runway 27. The airport property is identified as a Airport Approach Zone (AA) zone based on City Zoning Ordinance, Chapter 9. Within the AA zone, airports are included in "uses permitted outright." The increased residential development located directly south of Runway 17-35 (zoned RR-5) is not highly compatible with existing airport operations. However, if only low-density development is permitted, the potential conflicts with airport operations will be relatively minor.

Airport Layout Plan Report

for

**John Day State Airport
John Day, Oregon**

prepared for the

**Oregon Department of Transportation
Aeronautics**

and

Grant County Airport Commission

Chapter Four
FACILITY REQUIREMENTS

INTRODUCTION

To properly plan for the future of John Day State Airport, it is necessary to translate forecast aviation demand into specified types and quantities of facilities that can adequately serve this identified demand. This chapter uses the results of the forecast and demand capacity analyses conducted in **Chapter Three**, as well as established planning criteria, to determine the airside (i.e., runways, taxiways, navigational aids, marking, and lighting) and landside (i.e., hangars, fixed base operator (FBO) facilities, aircraft parking apron, fueling, automobile parking, and access) facility requirements.

The objective of this effort is to identify in general terms, the adequacy or inadequacy of the existing airport facilities and outline what new facilities may be needed to accommodate forecast demands. Having established facility requirements, alternatives for providing these facilities will be evaluated in **Chapter Five** to determine the most cost-effective and efficient means for implementation. The type of facilities required for a specific airport is also dependent upon the type and volume of aviation activity expected at the airport.

AIRPORT DESIGN STANDARDS

The selection of the appropriate design standards for the development of airfield facilities is based primarily upon the characteristics of the aircraft which are expected to use the airport. The most critical characteristics are the approach speed and wingspan of the critical design aircraft anticipated for the airport. Planning for future aircraft use is particularly important because design standards are used to determine separation distances between facilities that could be very costly to relocate at a later date.

Federal Aviation Administration (FAA) **Advisory Circular (AC) 150/5300-13, Airport Design**, serves as the primary reference in planning airfield facilities. **FAR Part 77, Objects Affecting Navigable Airspace**, defines airport imaginary surfaces which are established to protect the airspace immediately surrounding a runway. The imaginary surfaces will be fully described in the Airport Plans section of this report. Airport imaginary surfaces should be clear of obstructions (i.e. structures, parked aircraft, trees, etc.) to the greatest extent possible.

FAA **Advisory Circular 150/5300-13** groups aircraft into five categories based upon their approach speed. Categories A and B include small propeller aircraft and certain smaller business jet aircraft which have approach speeds of less than 121 knots. Categories C, D, and E consist of the remaining business jets as well as larger jet and propeller aircraft generally associated with commercial and military use; these aircraft have approach speeds of 121 knots or more. Most aircraft utilizing John Day State Airport are included in Categories A and B.

The advisory circular also establishes six aircraft design groups, based on the physical size (wingspan) of the aircraft. The categories range from Airplane Design Group (ADG) I, for aircraft with wingspans of less than 49 feet, to ADG VI for the largest commercial and military aircraft. Most aircraft operating at John Day are included in Airplane Design Group I and II.

Design Aircraft

The Beechcraft Baron or Cessna 402 represent the typical light and medium twin-engine aircraft which currently use the airport. These aircraft are included in Airplane Design Group I and Approach Category B. In addition to the predominate ADG I activity, the airport also has slightly less than 500 annual Design Group II aircraft operations, including a Cessna Citation II and USFS Shorts Sherpa twin-engine turboprop. It is anticipated that the level of ADG II activity will increase during the current planning period. The Cessna Citation II, which currently operates at the airport, represents the future design aircraft. The Citation II and Shorts Sherpa are included in Airplane Design Group II and Airplane Approach Category B. Although the operating weight of the Sherpa

is considerably greater than the Citation, they operate at John Day on a very limited basis. The impacts associated with pavement strength are discussed later in this chapter.

It is recommended that ADG I standards be initially applied to the runway-taxiway system at John Day, with a future upgrade to ADG II standards later in the planning period. Accordingly, Airport Reference Codes (ARC) B-I and B-II would be appropriate for existing and ultimate activity, based on the selection of the critical aircraft. Airfield design standards outlined in Table 4-1 are presented for ADG I and II.

Airspace

The airport is surrounded by high terrain in all directions, with the nearest high terrain being located to the south of the runway. A photoslope survey was conducted at the airport in May, 1989. The approaches for both Runway 17 and 34 were reported as being free of obstructions. Mountains located south of the airport do not penetrate the 5,000-foot visual approach surface. The survey indicated that Runway 9 had a tree located approximately 215 feet from the end of the runway (112 feet south of extended centerline), with a top elevation four feet higher than the runway end. This provided an unobstructed 3:1 slope for the runway. Additional data for the approach was not provided, although based on the photographic support, it appears that removal of the tree would provide a relatively unobstructed approach. No obstructions to the Runway 27 approach were identified within its 20:1 surface. The 1979 Approach and Clear Zone Plan depicts terrain penetrations within the conical surface directly south of Runway 16-34 (17-35).

The location of building restriction lines (BRL) is dependent on, and should encompass the runway protection zones (RPZ), runway object-free area (OFA), and should provide adequate separation for existing or planned parallel taxiways. Based on the existing and projected use of the airport, it is assumed that the runways may accommodate visual and possibly nonprecision approaches. The existing building restriction line (BRL) on Runway 17-35 is located 300 feet from runway centerline. This separation will not accommodate a parallel taxiway centerline to fixed/moveable object based on the ultimate ADG II standards or the clearances associated with future instrument approach procedures for the runways. The criteria which applies to locating the future BRL is described below.

Instrument Approach Capabilities

Another consideration has recently come to light, which has the potential of significantly affecting future development of facilities on the east side of Runway 17-35. Establishing an instrument

approach at John Day has been identified as a high priority. The FAA has begun a preliminary analysis of the instrument approach capabilities at John Day. Using criteria which will be applied to a global positioning system (GPS), the evaluation has identified two possible options. Based on obtaining the lowest approach minimums possible, it appears that a straight-in approach to Runway 9 will provide the best minimum descent altitude (MDA) (in the range of 400 feet above ground level), with one mile visibility. The missed approach procedure (MAP) requires a climbing left turn (about 35 degrees to the left, then direct to the Kimberly VOR. In contrast, the straight-in approach to Runway 17 would provide minimums in the 1,100-foot AGL range with one mile visibility; the MAP would require a climbing right turn (120 degrees) to the Kimberly VOR. circle-to-land minimums would also be provided to each runway. Neither Runway 35 or 27 will meet the FAA criteria for straight-in nonprecision instrument approaches. Locally, pilots seem to favor an approach to Runway 17.

The primary considerations will be typical aircraft operating requirements, particularly as related to the limited length of Runway 9-27. Another question is how the circle-to-land minimums based on a Runway 9 approach will compare with the straight-in minimums for Runway 17. The FAA will be evaluating these issues in the months to come, as design of the procedure continues.

However, as part of upgrading the instrument approach capabilities of the airport, it is also necessary to upgrade the FAR Part 77 imaginary surfaces. For nonprecision instrument runways used by small aircraft, the primary surface is 500 feet wide, centered on the runway. The primary surface is a rectangular plane of airspace which rests on the runway (at centerline elevation) and extends 200 feet beyond the runway end; the width depends on the runway category and type of approach (i.e. visual, nonprecision, precision) The inner portion of the runway approach surface extends beyond the end of the primary surface. At the outer edge of the primary surface, is the transitional surface, a plane of airspace which rises perpendicularly at a slope of 7 to 1, until reaching an elevation 150 feet above runway elevation. Based on FAR Part 77 standards, this surface should be free of obstructions (i.e. parked aircraft, structures, trees, etc.). The problem which is created at John Day when a nonprecision instrument approach is planned for Runway 17-35 is that the primary surface will extend outward to a distance of 250 feet from runway centerline (this is also the location of the taxiway centerline). Per FAR Part 77 standards, the 7:1 slope will begin at that point. The location of structures should be determined by their ability to remain beneath the 7:1 surface. Assuming that the hangar development area is level with the runway elevation, a hangar with a 20-foot top elevation would need to be 140 feet from the beginning of the transitional surface; add the 250 feet required for one-half of the primary surface width, and the building would be located approximately 390 feet from runway centerline. It may also be possible to establish the BRL at a point where a 15-foot building could be accommodated; the airport would then need to limit development along the BRL to lower profile hangars.

Table 4-1
FAA RUNWAY DIMENSIONAL STANDARDS
AIRPLANE DESIGN GROUP I/II

	ADG I/ADG II <u>(feet)</u>
Runway Length	4,970/5,340 ^a
Runway Width	60/75
Runway Shoulder Width	10/10
Runway Safety Area Width	120/150
Runway Safety Area Length (Beyond Rwy End)	240/300
Obstacle-Free Zone	250/250
Object Free Area Width	250/500
Object Free Area Length (Beyond Rwy End)	300/600
Primary Surface Width	250/500*
Primary Surface Length (Beyond Rwy End)	200/200*
Runway Protection Zone Length	1,000
Runway Protection Zone Inner Width	500
Runway Protection Zone Outer Width	700
Runway Centerline to:	
Parallel Taxiway Centerline	150/240
Aircraft Parking Area	125/250
Building Restriction Line	315.5 ^b
Taxiway Width	25/35
Taxiway Shoulder Width	10/10
Taxiway Safety Area Width	49/79
Taxiway Object Free Area Width	89/131
Taxiway Centerline to Fixed/Movable Object	45.5/65.5

^a Runway length required to accommodate 95 and 100 percent of General Aviation Fleet 12,500 pounds or less. The existing runway will accommodate approximately 85% of the fleet under most operating conditions.

^b This distance will protect the parallel taxiway object free area.

* Visual and Nonprecision Utility Runway Dimensions (Per FAR Part 77); all other dimensions reflect visual runways and runways with not lower than 3/4-statute mile approach visibility minimums (per AC 150/5300-13, Change 4) within the respective design group. RPZ dimensions bases on visual and not lower than 1-mile approach visibility minimums

The existing BRL is located 300 feet from the runway centerline. Earlier discussions identified a need to relocate the BRL to at least 315.5 feet in order to maintain adequate clearances from the parallel taxiway. Further discussions will be held with the FAA regarding this issue. The final decision will be a major factor in identifying future building layouts in the existing hangar zone. No future structures should penetrate the surfaces; existing structures and those currently under development do not pose a significant airspace concern. The new location of the BRL will be depicted on the updated Airport Layout Plan (Drawing 1), contained in Chapter Five.

AIRSIDE REQUIREMENTS

Note: During the summer of 1996, Runway 17-35, the parallel taxiway, and the main apron were reconstructed; Runway 9-27 received drainage repair, crackfilling, and a sealcoat. Airport perimeter fencing was also installed. These recent improvements are not reflected in the facility requirements analyses presented below, which were conducted in 1995.

Airside facilities are those directly related to the arrival and departure and movement of aircraft:

- **Runways**
- **Taxiways**
- **Airfield Marking and Lighting**
- **Navigational Aids**

RUNWAYS

The adequacy of the existing runway system at John Day State Airport was analyzed from a number of perspectives including runway orientation, airfield capacity, runway length, and pavement strength. From this information, the runway requirements for the airport were determined.

Runway Orientation

The orientation of runways for takeoff and landing operations is primarily a function of wind velocity and direction, combined with the ability of aircraft to operate under adverse wind conditions. Runway 17-35 at John Day State Airport is oriented in a north-south direction, with Runway 9-27 oriented in an east-west direction. As a general rule, the primary runway at an airport is oriented as closely as practical in the direction of prevailing winds. When landing and taking off, aircraft are able to maneuver on a runway as long as the wind component perpendicular to the aircraft's direction of travel (defined as crosswind) is not excessive.

The maximum allowable crosswind depends not only on the size of aircraft, but also on the wing configuration and the condition of the runway surface. For runway planning and design, a crosswind component is considered excessive at 12 miles per hour for smaller aircraft (gross takeoff weight 12,500 pounds or less) and 15 miles per hour for larger aircraft. FAA planning standards indicate that an airport should be planned with the capability to operate under allowable wind conditions at least 95 percent of the time. The wind coverage for Runway 17-35 is estimated at 87.6 percent at 12 miles per hour. Runway 9-27 has 93.4 percent wind coverage. The combined coverage provided by Runway 9-27 and 17-35 is 99.5 percent at 12 miles per hour. Wind data indicate that prevailing winds are generally east-west.

Runway Length

Runway 17-35 has a length of 4,500 feet. The determination of the recommended runway length is based primarily upon airport elevation, mean maximum daily temperature of the hottest month, runway gradient, and the critical aircraft type expected to use the runway. The existing runway length is considered inadequate to accommodate all small aircraft in the general aviation fleet.

Based on local conditions and the methodology outlined in AC 150/5300-13, a runway length of 5,400 feet would be required to accommodate 100 percent of small aircraft (12,500 pounds or less maximum gross takeoff weight) in the general aviation fleet. A 500-foot extension (to 5,000 feet), would accommodate approximately 95 percent of the GA fleet. With the existing length, approximately 90 percent of the general aviation fleet can be accommodated under most conditions.

An initial 500-foot runway extension would represent a significant improvement above the current length and provide an incremental increase in capabilities (up to 95 percent of the GA fleet). A second runway extension of 400 feet (to 5,500 feet) would allow the runway to accommodate a wider range of multi-engine and business jet aircraft, which have higher accelerated-stop distance requirements. It appears that an ultimate length of 5,400 feet would adequately accommodate the majority of the general aviation fleet under most conditions. Based on current demand levels, it would be appropriate to provide the runway extensions in two stages, as warranted. The acquisition of property or avigation easements necessary to accommodate the ultimate runway length, safety area, and approaches should be initiated early in the planning period.

FAA Runway Lengths Recommended For Airport Design:

Airport Elevation: 3,697 MSL

Mean Max Temperature in Hottest Month: 90.3F

Maximum Difference in runway centerline elevation: 23 feet (17-35) and 44 feet (9-27)

Current Runways 4,500 feet (17-35) and 3,436 feet (9-27)

Small Airplanes with less than 10 seats

75 percent of these airplanes 3,880 feet

95 percent of these airplanes 4,970 feet

100 percent of these airplanes 5,340 feet

The FAA design standards indicate that secondary (crosswind) runways are generally eligible for funding at length up to 80 percent of the primary runway. Extending Runway 9-27 to 4,000 feet was identified as a long-term improvement on the previous airport layout plan; the extension would significantly improve the utilization of Runway 9-27.

The existing width of Runway 17-35 is 50 feet; the recommended width for runways included in Airplane Design Group (ADG) I is 60 feet. The widening of the runway should be combined with the initial reconstruction project. A future upgrade to 75 feet will be needed to meet ADG II standards. Runway 9-27 is 60 feet wide and meets ADG I standards; widening the runway to 75 feet would be identified as a long-term improvement due to the need to first upgrade the airport's primary runway.

Airfield Pavement

The most recent FAA 5010 Airport Record Form lists pavement strength for Runway 16-34 (17-35) at 8,000 pounds for aircraft with single-wheel (SW) landing gear and Runway 9-27 at 12,000 pounds SW. The surface of Runway 17-35 has experienced a substantial amount of reflective cracking in recent years. As noted in the Inventory Chapter, Runway 17-35 is currently in need of reconstruction and resurfacing.

A 1989 pavement evaluation indicated that Runway 16-34 (17-35) was in "very good" condition with cracking (.75 to 1.5 inch) being the major problem. The runway's average Pavement Condition Index (PCI) rating was 71. The parallel taxiway was rated "good," with conditions similar to the main runway; the average PCI rating was 64. The evaluation recommended a short term slurry seal

and long term overlay for Runway 16-34 (17-35).

Runway 9-27 was rated "excellent" with an average PCI of 92. Only minor cracking was visible and some raveling. A fog coat was recommended for Runway 9-27 in the next two to three years. The main apron was rated "good" with an average PCI of 51. Reconstruction and overlay of the apron was recommended in the short term.

The most recent pavement evaluation at John Day conducted in August 1994 yielded ratings which were generally consistent with the 1989 evaluation (with five additional years use). All pavements surfaces were rated "fair" or better, although the condition of Runway 17-35 (deep cracking, etc.) was considered "poor" by users. PCI ratings included: **54** - Runway 17-35; **90/98** - Runway 9-27; **100** - forestry apron; **44/46** - Runway 17-35 Parallel Taxiway; **46** - main apron; and **74/80** - hangar taxilanes. A copy of the 1989 and 1994 pavement survey is included as **Appendix B**.

Recent visual inspections indicate that, with the exception of Runway 9-27, all airfield pavements are in poor condition. Despite aggressive efforts to fill the reflective cracks (which have widened from 1 to 3 inches), Runway 17-35 is becoming very rough for aircraft use.

The following pavement facility needs have been identified:

- . *Runway 17-35 requires reconstruction with limited frost protection and a new asphalt surface as soon as possible. The runway will need to be widened to 60 feet to meet ADG I standards, and 75 feet for ADG II standards.*
- . *The Runway 17-35 parallel taxiway also requires reconstruction; short-term resurfacing may be possible; a long term need would be to widen the taxiway to 35 feet (ADG II).*
- . *Runway 9-27 requires a sealcoat .*
- . *The main apron will require reconstruction and/or resurfacing.*
- . *Future pavement designs should be based on 12,500 pound SW.*

As noted earlier, the weights of the typical design aircraft operating at John Day State Airport are at or below 12,500 pounds. The primary exceptions to this are the larger aircraft used to transport smokejumpers and supplies during the fire season. Aircraft such as the Shorts Sherpa, with a maximum takeoff weight of 25,500 pounds, typically account for less than 50 operations per season. Although the level of activity will vary from season to season, it is not expected that this aircraft

activity will consistently increase above one hundred or two hundred operations per season. Despite this relatively limited activity, it may be appropriate for the sponsor to conduct a cost-benefit analysis related to the "limited" use of the runways by the larger aircraft. An evaluation of the increased pavement wear associated with these aircraft could indicate whether the 12,500 pound weight bearing capacity will provide the expected durability. If the pavements are likely to require significant maintenance or resurfacing as a result of the limited activity, it may be appropriate to increase the weight bearing capacities as a preventative measure.

Airfield Capacity

As noted in the Inventory Chapter, hourly and annual runway capacity at John Day is considered to be adequate through the planning period, with both the current runway configuration and the addition of a parallel taxiway on Runway 9-27. The addition of a parallel taxiway on Runway 9-27 and an instrument approach procedure for the airport would increase capacity, although because the airport does not experience any significant capacity problems on an annual basis, the primary benefits would be associated with relieving congestion during peak activity periods and during poor weather conditions.

Theoretical hourly capacity is approximately 59 to 72 operations during visual flight rules (VFR) conditions with Runway 9-27 and approximately 80 to 93 operations with Runway 16-34 (17-35). Airport estimates of runway use indicate that approximately 60 percent of fixed wing traffic occurs on Runway 17-35, with 40 percent on Runway 9-27. At airports without air traffic control towers, it is assumed for capacity purposes, that only one runway may be in use at any moment. Therefore the hourly and annual airfield capacity levels reflect a single runway operation. The annual service volume (ASV) for the airport is currently estimated at 42,000 operations, compared to 20-year forecasts of less than 13,000 operations. The airport is currently operating at less than 15 percent of its ASV. FAA Order 5090.3B, **Field Formulation of the National Airport Systems**, indicates that improvements should be considered when operations reach 60 percent of annual capacity. Based on forecast operations, the runway will continue to operate well below capacity with or without taxiway improvements during the twenty-year planning period.

TAXIWAYS

Taxiways are constructed primarily to facilitate aircraft movements to and from the runway system. Some taxiways are necessary simply to provide access between apron and runways, while other taxiways become necessary as activity increases and safer and more efficient use of the airfield is needed. Runway 17-35 is served by a full-length parallel taxiway. Future extensions of the runway

should also incorporate extensions of the parallel taxiway.

Runway 9-27 is not served by a parallel taxiway. The threshold of Runway 27 is accessed from the Runway 17-35 parallel taxiway. As noted, above airfield capacity will be adequate during the planning period, however, the addition of a parallel taxiway is considered a basic airfield improvement which will provide an increased level of safety and convenience at this uncontrolled airport. Runway 9-27 has a substantial gradient, which affects runway visibility. Aircraft landing on Runway 27 are required to back-taxi the entire length of the runway to reach the parallel taxiway. This has created some congestion on the runway during peak summer periods.

AIRFIELD INSTRUMENTATION AND LIGHTING

Medium-intensity runway edge lighting (MIRL) is standard for general aviation runways. Runway end identifier lights (REIL) which provide rapid and positive identification of the approach end of the runway should also be considered for Runway 17 and 9. The addition of a visual guidance indicator (VGI) system is recommended for Runways 9 and 27. The high terrain located south of the airport may not permit standard installation of a VGI system on Runway 35. A VGI system requires an unobstructed approach surface which extends outward 10 degrees on either side of the extended runway centerline, with a radius of four miles beyond the runway threshold. Precision Approach Path Indicators (PAPI) are currently used as the primary VGI system.

The FAA is currently in the process of designing a non-precision Global Positioning System (GPS) instrument approach procedure for Runway 9 at John Day. Depending on site constraints (terrain), the procedure may provide straight-in minimums for Runway 9 and circling minimums for the other runways. According to an article the September 19, 1994 issue of **Aviation Week and Space Technology**, the FAA's GPS program is currently targeting 1997 for initial certification of Category I ILS type GPS approaches for airports with existing Cat. I ILS approaches. Approval of new GPS approaches at airports currently without conventional instrument approach capabilities will likely follow after the initial certifications are completed.

LANDSIDE FACILITIES

The purpose of this section is to determine the space requirements during the planning period for the following types of facilities normally associated with general aviation operations areas:

- **Hangars**
- **Local and Itinerant Apron**
- **General Aviation Terminal Area**

HANGARS

Currently, the majority of based aircraft at John Day State Airport are stored in hangars. There are 24 general aviation based aircraft. Local pilots have indicated an interest in constructing additional hangars at John Day. The airport is currently negotiating with two or three potential tenants interested in hangar construction.

The regional location of an airport often determines the demand for hangar facilities at that airport. For example, airports situated in colder climates tend to store more based aircraft in hangars. It is anticipated that the level of hangar utilization will remain relatively high during the planning period. It is anticipated that approximately 70 percent of based aircraft will utilize hangar storage.

Following the determination of the total number of based aircraft to be housed in hangars, it is then necessary to determine the percentages of aircraft which would utilize conventional hangars and T-hangars. There is an increasing trend toward T-hangar storage preference by general aviation users. T-hangar storage provides aircraft owners with more privacy and greater ease in obtaining access to the aircraft. The principal uses of conventional hangars are for housing fixed based operation-related activities and storing large aircraft and aircraft needing maintenance.

The final step in the process of determining hangar requirements involves estimating the area necessary to accommodate the required hangar space. A planning standard of 1,000 square feet per based aircraft stored in T-hangars was used. For conventional hangars, a standard of 1,200 square feet for single-engine and multi-engine aircraft was used. These figures were then applied to the aircraft to be hangared to determine the area to be devoted to hangar facility requirements through the planning period. The airport has roughly 260,000 square feet of area available for hangar construction between the existing hangar area and the end of Runway 17. It is anticipated that all general aviation hangar demand during the current planning period can be met within this area. The area will also be capable of accommodating larger conventional hangars. The hangar needs for John Day presented in Table 4-2 indicate that additional hangar space will be required during the planning period.

LOCAL AND ITINERANT APRON

Aircraft parking apron should be provided for locally based aircraft which are not stored in hangars and for transient aircraft visiting the airport. Currently, the majority of locally based aircraft at John Day are stored in hangars. John Day State Airport has a paved main apron and a small tiedown area which accommodates local and itinerant aircraft. The total apron area is approximately 6,400 square yards. However, this area accommodates corporate itinerant parking, aircraft tiedowns, fueling, and helicopter parking. The apron areas combine to provide tiedowns for approximately 10 to 12 light aircraft. An additional 2,000 square yards of hard-surfaced parking area is located directly south of the apron, although this is primarily used in support of forestry-related activity.

FAA Advisory Circular 150/5300-13 suggests a methodology by which itinerant parking requirements can be determined from knowledge of busy-day operations. At John Day State Airport, the number of itinerant spaces was determined to be approximately 30 percent of busy day itinerant operations. The FAA planning criterion of 360 square yards per itinerant aircraft was applied to the number itinerant spaces to determine future itinerant ramp requirements. Based aircraft tie-downs were planned at 300 square yards per aircraft. Itinerant aircraft tie-downs are planned at 360 square yards per aircraft. At John Day, parking requirements associated with based aircraft, transient aircraft, and seasonally based aircraft are considered. For the short-term, it appears that 20 tiedowns, in addition to space for corporate itinerant aircraft and itinerant rotorcraft parking would be required with approximately 10,000 square yards of apron. Long term requirements include 28 light aircraft tiedown positions, with corporate and rotorcraft parking, and approximately 14,200 square yards of apron. The aircraft parking area requirements are summarized in Table 4-2. Based on forecast demand, expansion of aircraft apron area to accommodate additional tie-downs would be required early, and again later, in the planning period.

SURFACE ACCESS REQUIREMENTS

The capacity of the primary airport access roadways appears to be adequate for the planning period. Vehicle access to the aircraft apron and hangar area is provided by a paved roadway which connects to Highway 395. Interest in providing airport access via the West Bench area also exists. Providing access through the south end of the airfield could affect approach clearances for Runway 35 (existing and future), extended runway safety area, and the USFS helipads. If the impacts on airport facilities can be prevented, and adequate security can be provided for airport tenants, access via the West Bench would be compatible with airport operations. Options for possible realignments of the existing gravel-surfaced roadway will be considered in the alternatives analysis.

SUPPORT FACILITIES

AVIATION FUEL STORAGE

Aviation gasoline (AVGAS) and Jet Fuel is available at John Day State Airport. The airport utilizes two 12,000 gallon underground tanks for fuel storage. Airport operator records indicate annual fuel sales have averaged approximately 41,000 gallons of AVGAS and 58,000 gallons of Jet Fuel over the last two years. If combined, this would average approximately 17 gallons of fuel sold per aircraft operation. This level of fueling activity is consistent with the type of activity which exists at John Day.

For the purposes of projecting fuel storage requirements, an average of 17 gallons of AVGAS and Jet Fuel was assumed for each aircraft operation. Storage requirements can be calculated based on peak month activity. In 1994, the peak month was estimated at 1,239 operations. The 17-gallons-per-operation average would indicate a need for the storage of approximately 21,150 gallons of fuel. In 2014, the peak month operations would be approximately 2,580 operations creating a need for approximately 43,900 gallons of fuel storage for a one month supply period. With a multiple deliveries scheduled during peak months, the existing capacity will be adequate well into the planning period. Adding additional storage capacity will be primarily dictated by market conditions.

The existing tanks are subject to increasingly stringent monitoring requirements. The airport sponsor indicates that the tanks are in good condition and will be used for the foreseeable future. Future replacement of the underground tanks with double-wall above ground tanks seems likely within the planning period. An area located adjacent to the main apron should be reserved for future fuel storage requirements.

AIRPORT UTILITIES

The airport has electrical service, provided by Eastern Oregon Electrical Coop. Water at the airport is limited to a single narrow line which enters the airport operations area from the east. The airport operations building has a septic tank. The limited availability of water on the airport creates some potential problems for fire protection. Improving water service at the airport to provide for fire protection is recommended.

**Table 4-2
John Day State Airport Facility Requirements**

Forecast Summary (Median Projection)

	1994	1999	2004	2009	2014
Based Aircraft	24	28	33	38	46
Annual Operations	5900	7560	8910	10260	12285
Peak Month	1239	1588	1871	2155	2580
Design Day	40	51	60	70	83
Peak Day	56	79	84	97	116
Peak Hour	11	16	17	19	23

Facility Requirements

Aircraft to be Hangared	15	20	23	27	32
Based Aircraft Tiedowns	8	8	10	11	14
Additional Seasonally-Based Aircraft	6	9	10	12	14
GA Transient Aircraft Tiedowns	7	9	10	12	14
Corporate Itinerant Parking	2	2	2	3	3
Total Fixed Wing Parking	23	29	32	38	45
Itinerant Rotorcraft Parking	1	2	2	3	3
Based Aircraft Tiedown @ 300 sy ea.	2400	2520	2970	3420	4140
GA Itinerant Aircraft Tiedown @ 360sy ea.	4576	6646	7249	8522	10072
Corporate Itinerant Parking @ 500 sy ea.	1000	1000	1000	1500	1500
Itinerant Rotor Parking @ 550 sy ea.	550	1100	1100	1650	1650
Total Apron Area	8526	11266	12319	15092	17362
Hangar Space Requirements (SF)		23520	27720	31920	38640

SECURITY

The airport has wire fencing around the property lines and between the main apron and airport access roadway. The existing perimeter fencing is inadequate to control animal entry at the airport. At least one major aircraft-animal collision has occurred at the airport within the last few years. Deer are commonly found on and around the runways. Upgraded airport perimeter fencing should be considered to protect all active airport areas including runway, taxiways, and aircraft tie-down and hangar areas. Although fencing the entire airport perimeter would provide the best deterrent to unwanted animal incursions, the highest security priority would be to fence along both sides and the ends of Runway 17-35. Although the limited fencing would not eliminate the current incursion problem, it could substantially reduce access to the airfield. The Oregon Department of Fish and Wildlife has provided a design specification for a chain-link fence which is more effective against a variety of animals. The fence is 76 inches high, with three strands of barbed wire along the top.

FACILITY REQUIREMENTS SUMMARY

A number of facilities requirements for John Day State Airport have been identified for the current twenty-year planning period. Recommendations have been summarized in **Table 4-3**. Some facilities will be capable of accommodating forecast demands through the planning period; other facilities will require minor to significant upgrading during the planning period. A number of new or reconfigured facilities will need to be planned to meet a variety of demands. As noted earlier, it appears that the property located within existing airport boundaries will not be adequate to accommodate substantial landside facility improvements. The next step in the planning process is to analyze alternatives that can accommodate these requirements. The next chapter will provide this analysis and recommend specific development alternatives for which are capable of accommodating projected demands through the twenty-year planning period and beyond.

Table 4-3
FACILITY REQUIREMENTS SUMMARY
 John Day State Airport

	<u>SHORT-TERM</u>	<u>LONG-TERM</u>
RUNWAYS		
Runway 17-35	Reconstruction & Resurface 500-ft extension; widen to 60 ft Sealcoat and Maintenance	Widen to 75 feet Sealcoat and Maintenance 400-ft Extension/Reserve
Runway 9-27	Crackfill, Sealcoat Pavement	500-ft Extension (Rwy 9)
TAXIWAYS		
	Parallel Taxiway Resurfacing Additional T-Hangar Access Txy.	Reconstruct Taxiway Widen to 35 feet Construct Parallel Taxiway - Runway 9-27
APRONS		
	Reconstruct Main Apron Expand Aircraft Tie-downs Reconfigure Main Apron Sealcoat Main Apron	Expanded Parking Apron Relocate Fueling Area North GA Apron
HANGARS		
	T-Hangar and Conventional Hangar Lease Area	T-Hangar and Conventional Hangar Lease Area
NAVAIDS		
	GPS Nonprecision Approach	Same
LIGHTING		
	PAPI (Rwy 17, 9 and 27) REIL (Rwy 17, 9 and 27) MIRL - Runway 17-35	MIRL - Runway 9-27 MITL - Rwy 17-35 Txy

Table 4-3
FACILITY REQUIREMENTS SUMMARY (Continued)
 John Day State Airport

	<u>SHORT-TERM</u>	<u>LONG-TERM</u>
ROADWAYS	None	Realign West Bench Access Roadway
FUEL STORAGE	Establish Fuel Storage Reserve	-----
SECURITY	Perimeter Fencing	Same Apron Flood Lighting
BUILDINGS	-----	Relocate Airport Operations Building
UTILITIES	Water Supply/Storage System Upgrade; Extend electrical connection to hangars	Same

Airport Layout Plan Report

for

**John Day State Airport
John Day, Oregon**

prepared for the

**Oregon Department of Transportation
Aeronautics**

and

Grant County Airport Commission

Chapter Five

**AIRPORT DEVELOPMENT ALTERNATIVES AND
AIRPORT LAYOUT PLAN**

The following descriptions provide an overview of development options and issues addressed in the John Day State Airport Layout Plan Study. The initial development concepts were general in nature, with the emphasis being placed on identifying overall facility needs at the airport. Each of the options were capable of accommodating forecast facility needs at the airport during the current twenty year planning period. The conceptual options were subject to extensive public review and comment, and were subsequently refined to provide the preferred alternative.

Overview

The evaluation phase of the Airport Layout Plan Update project began with a group of preliminary development concepts being presented at two public meetings in John Day. The process of identifying and evaluating airport needs provided an opportunity for the local community to be directly involved with planning of airport improvements. Airport users, the general public, the Grant County Airport Commission, and Oregon Department of Transportation - Aeronautics each provided input regarding the development concepts, which allowed for the development of more detailed alternatives. Based on the facility requirements analyses, the highest priority need identified was the reconstruction and widening (60 feet) of the airport's primary runway (Runway 17-35). Extending the runway, resurfacing or reconstructing the parallel taxiway, and accommodating additional light aircraft parking and hangar areas were also identified as high priorities.

Improving/realigning the West Bench access roadway was also identified as a facility need, due to increasing interest in using the roadway as a primary access route to the airport. With its current alignment, the roadway is not considered suitable for significantly increased vehicle traffic. The roadway passes very near the existing forestry helicopter landing areas, traversing the approach surfaces for the helipads. Vehicles traveling on the roadway passing through the approach area create obstructions to the approach surface. Options for relocating the helipads are limited due to the minimal amount of usable land area between the existing roadway and the runway-taxiway system. As a result, a portion of the existing roadway should be realigned to the east in order to provide adequate clearance for active aircraft operating areas.

Following the public meetings in which the preliminary concepts were presented, two additional considerations were identified. One issue was related to a proposed instrument approach procedure (IAP) for the airport, particularly with regard to the runway to be selected for the IAP. The second issue was a heightened concern expressed by ODOT Aeronautics related to the increasingly limited availability of funding for projects, and in turn, its potential impact on reconstructing Runway 17-35.

The instrument approach issue centered on the FAA's ongoing activities in designing a global positioning system (GPS) procedure for the airport. Based on preliminary FAA airspace evaluations, it appears that lower approach minimums and a less complex missed approach procedure can be obtained on an approach to Runway 9 versus Runway 17. From an instrument approach planning perspective, Runway 9 is considered a better choice by the FAA. This, however, is not consistent with the FAA's airport development program prioritization between primary and secondary runways. The FAA Airports Division has expressed some concerns that establishing the airport's only instrument approach on the secondary runway could result in demands for facility improvements (increased runway length, taxiway access, etc.) which may not be met due to anticipated long-term funding constraints and the need to maintain the main runway. The instrument approach issue will be addressed within the FAA, although the current plan (from the airspace office) is to design the approach for Runway 9. The other factors associated with instrument approach procedure at John Day, and its affect on airfield planning are discussed below.

The issues surrounding the proposed instrument approach procedure on Runway 9 led to consideration of designating Runway 9-27 as the primary runway at John Day. Based on the available wind rose data, Runway 9-27 has better overall wind coverage than 17-35, and as noted earlier, the potential instrument approach minimums are lower. The option of changing the primary runway designation was available and could be supported based on the factors mentioned above. These factors coupled with the substantial cost involved with reconstructing Runway 17-35, created a valid issue requiring further consideration.

The funding issue was related to the anticipated cost (approximately \$2.0 million) associated with

reconstructing, widening and extending Runway 17-35 and the parallel taxiway to a 5,000-foot length. Upgrading Runway 9-27, with extended length and a parallel taxiway was identified as an alternative to repairing Runway 17-35.

As noted above, Runway 9-27 has better overall wind coverage and instrument approach capabilities than Runway 17-35. However, Runway 9-27 is considerably shorter (although wider) than Runway 17-35 and it is not served by a parallel taxiway system. Many local pilots also indicate that despite the wind coverage data, Runway 17-35 offers better overall utilization than Runway 9-27 throughout the year. Basic cost and technical analyses provided by the Consultant to ODOT Aeronautics and the Airport Commission indicated an overall cost of approximately \$1 million for upgrading Runway 9-27. The most difficult element of this option again reverted back to funding. ODOT Aeronautics indicated that if substantial improvements were made to Runway 9-27, it was unlikely that Runway 17-35 would receive any future funding consideration by the FAA. At some point in the future, the runway would be closed. Local airport officials and airport users generally did not support improving Runway 9-27 at the expense of maintaining Runway 17-35, with the airport becoming a single runway facility. However, everyone recognized that the uncertainty associated with funding would eventually dictate what, if any, runway improvements could be made to the airport.

Following a series of meetings between the Consultant, ODOT Aeronautics, and local airport officials to examine these issues, it was determined that a decision must be made in terms of establishing realistic development priorities before the current ALP project could continue.

Over the course of several months, discussions were held between ODOT Aeronautics and the Airport Commission in an attempt to identify a "preferred alternative." Despite some concerns regarding the availability of funding, the reconstruction and extension of Runway 17-35 was selected as the preferred alternative by the Airport Commission. ODOT Aeronautics, had expressed concerns about the ability to obtain FAA funding for the project, but did not oppose the local recommendations. Although the uncertainty of funding remains an issue, it became necessary to move forward with the planning project so the sponsor could focus its efforts on obtaining funding.

With Runway 17-35 retained as the primary runway, the basis for the preferred development concept was firmly established. Further options may need to be considered should funding limitations become a significant constraint. For example, a basic reconstruction project at the current length of 4,500 feet would provide, some, but not all of the desired benefits to users. Extending the runway without a parallel taxiway extension is another option. Deferring resurfacing or reconstruction of the parallel taxiway may also be required.

Instrument Approach Procedure

Previous planning exercises at John Day State Airport considered to the best potential for nonprecision instrument approach, such as nondirectional beacon (NDB) approach. An NDB approach could provide guidance into to the airport environment, with extended visual approach segments to the runways. However, with the advent of GPS, a non-precision straight-in instrument approach to a specific runways has become both technically and economically feasible at John Day.

With nonprecision instrument approach *to a specific runway*, as opposed to *the airport environment*, the airport airspace protections, including building clearances require upgrading. For example the existing primary surface width (see FAR Part 77.25) on Runway 17-35 is 250 feet wide and is based on the earlier instrument approach assumptions. The primary surface width increases to 500 feet with a nonprecision approach to a runway. For Runway 17-35, this dimension, and the accompanying transitional surface slope, will move further east and west of the runway. Parked aircraft and structures, including aircraft hangars, should not penetrate these surfaces. Revisions to the building restriction line will also be recommended. These changes will reduce (narrow) the area available east of the runway-taxiway system for hangar construction. Future aircraft parking aprons will need to ensure that aircraft tail heights do not penetrate the appropriate surfaces.

As noted earlier, the issues surrounding a future GPS instrument approach procedure at John Day State Airport center on runway selection. The FAA continues to move forward with plans to design the GPS approach for Runway 9. However, for planning purposes, it was determined that both runways would be planned for future nonprecision instrument approach capabilities (Runways 9 and 17). Future landside facilities will be configured accordingly.

PRELIMINARY DEVELOPMENT CONCEPTS

AIRPORT DEVELOPMENT CONCEPT

Runways

As noted earlier, Runway 16-34 has recently been redesignated 17-35. Text or graphic references to the runway with the former and current designation may exist; for the purposes of this evaluation, both references may be associated with the current Runway 17-35.

The Facility Requirements Analysis identified reconstruction of Runway 17-35, including widening to 60 feet and extending the runway to 5,000 feet as a high priority project. A second extension (400 feet) was also identified as a long term need, but is considered to be a low priority based on the availability of funding. The 1979 airport layout plan identified two extensions for Runway 17-35: a 500-foot extension at the south end and a 400-foot extension at the north end. An examination of the site indicates that a 500-foot southern runway extension and extended runway safety area would require a relocation of the West Bench access road further to the south in order to meet FAA dimensional standards. However, the area immediately north of the runway will be able to accommodate the runway and safety area extension without disrupting existing roadways.

Improvements to Runway 9-27 include adding taxiway access and extending the Runway to 4,000, although those projects have a lower priority. It is noted that further extension of Runway 9-27 may be retained as secondary option in the event that funding of the Runway 17-35 reconstruction becomes unfeasible. For planning purposes, runway extension reserves will be identified on the airport layout plan drawing. As a secondary runway, Runway 9-27 would have an ultimate length of 4,000 feet, which is approximately 80 percent of the primary runway length.

For Runway 17-35, the existing length of 4,500 feet will accommodate approximately 85 to 90 percent of the General Aviation fleet (aircraft under 12,500 pounds) under most conditions. A 500-foot extension, to 5,000 feet, will enable the runway to accommodate 95 percent of the GA fleet, including a wider range of multi-engine piston and turboprop aircraft and small business jet aircraft, which have higher accelerated-stop distance requirements, under more demanding conditions. Use of the runway by larger aircraft associated with forestry operations, such as the Shorts Sherpa (freighter version of Shorts 330-200) is expected to remain seasonal and below levels necessary to justify selection as the critical design aircraft by FAA criteria. The heavier operating weight (25,500 pound max gross takeoff weight) of the Sherpa and other similar aircraft, can be accommodated on a limited basis on pavements designed at 12,500 pounds without causing excessive wear. The Sherpa also requires relative short runway lengths for takeoff and is able to operate on the existing runways at John Day under most conditions.

It is recommended that the 500-foot runway extension be planned for the Runway 17 end. A future nonprecision instrument approach is proposed for Runway 17 (20:1 approach slope); this slope can be maintained with both the existing and ultimate runway length. A roadway reserve passing along the northern end of the airport will traverse the future nonprecision approach surface, but vehicles (15 feet) will remain below the approach surface due to the downward sloping terrain. The runway extension, extended runway safety area and object free area can be accommodated within existing airport property boundaries, although the runway protection zone will extend beyond airport property. Acquisition of property or avigation easements necessary to accommodate the ultimate Runway 17 protection zone and approach, should be initiated early in the planning period.

The existing width of Runway 17-35 is 50 feet. The FAA-recommended width for Design Group I runways of 60 feet should be used for the initial reconstruction project. As noted in the Facility Requirements analysis, justification for upgrading the runway to ADG II standards (75 foot width) is expected later in the current planning period. Upgrading runway edge lighting from low to medium intensity (MIRL) would be incorporated into the reconstruction project on Runway 17-35. The overall airfield development concept is depicted in **Figure 5-1**.

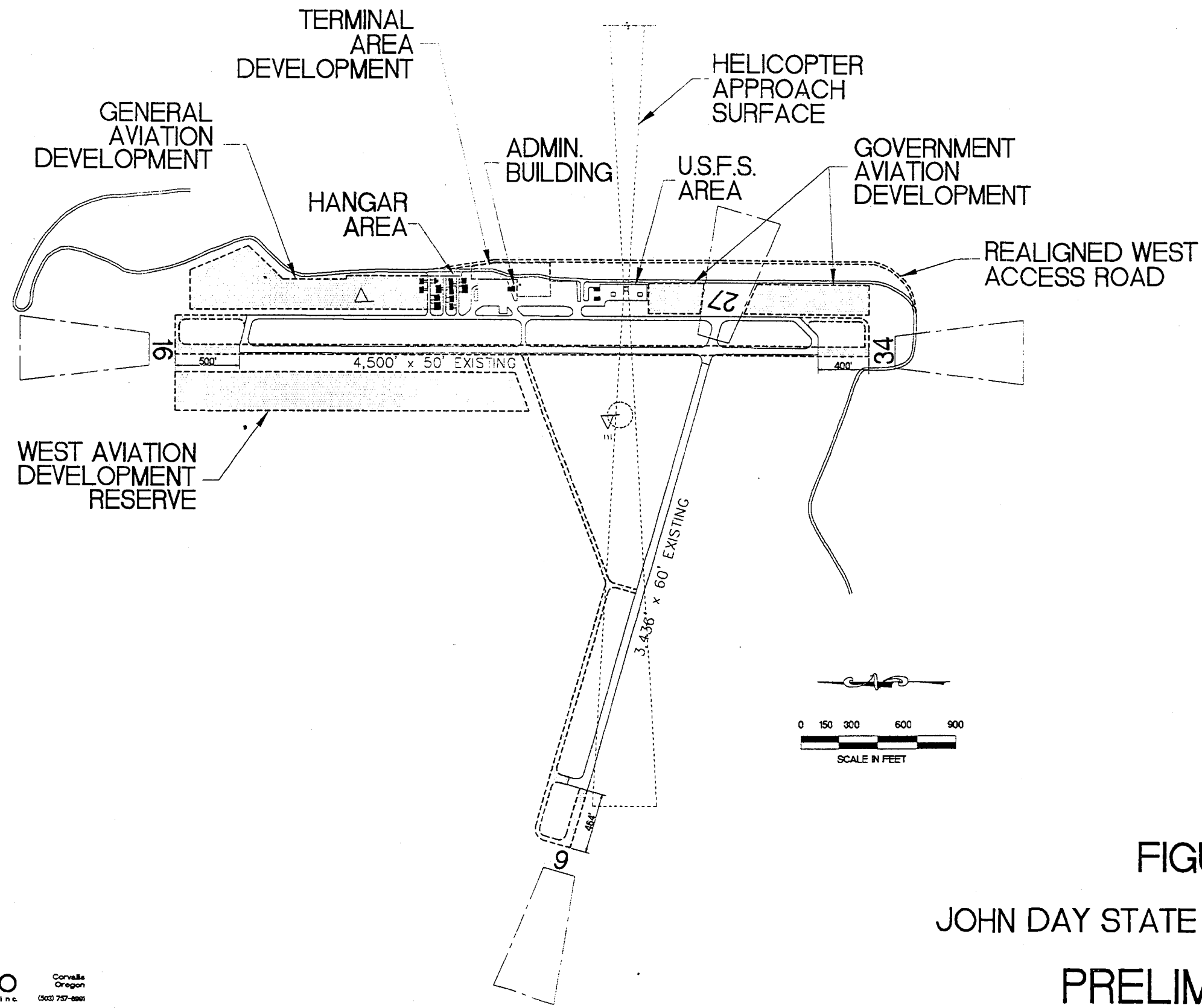

FIGURE 5-1
 JOHN DAY STATE AIRPORT
 PRELIMINARY
 DEVELOPMENT CONCEPTS

Taxiways

The Facility Requirements analysis identified the need to resurface or reconstruct the parallel taxiway on Runway 17-35, and to extend the taxiway in conjunction with a runway extension project. Other recommended taxiway improvements include adding two 300 by 20-foot taxilanes in the North GA Hangar Area between planned hangar rows. The taxilanes will connect the landside aviation areas to the runway-taxiway system. Upgrading taxiway access to Runway 9-27 was also identified as a facility need. A 1,900-foot (35 feet wide) taxiway would be extended from near the midpoint of Runway 17-35 at the existing exit taxiway located directly opposite the main apron. The new taxiway would travel in a southwest direction, until intersecting with a parallel taxiway reserve (240 feet from runway centerline) on the north side of Runway 9-27. A connecting taxiway would also be extended to the Runway 9-27. A second phase taxiway project would provide a 2,200-foot parallel taxiway section to the future Runway 9 end.

It is recommended that ADG II standards for separation and dimensions be used for the taxiways. This is based on the anticipated upgrade to ADG II standards within the current planning period and the expense which would be associated with upgrading/relocating at a later date. Parallel taxiways should be 35 feet wide and be located 240 feet from runway centerline; the existing 250-foot runway-taxiway separation on Runway 17-35 would be maintained unless both surfaces were reconstructed. Aircraft run-up areas (approximately 340 by 170 feet) should be located at the ends of Runways 17, 35 and 9. Taxiway edge lighting may be added later in the planning period, although initially, reflective edge markers would be adequate.

LANDSIDE DEVELOPMENT CONCEPT #1

Landside Development Concept #1 (Figure 5-2) identifies areas for expansion of general aviation and government-related aviation development. The primary elements of Concept #1 include development of a new general aviation apron north of the existing hangar rows which incorporates a designated corporate aviation area for larger business aircraft parking and hangars. Four additional T-hangar rows would be located directly north of proposed apron, with additional hangar development reserve continuing to the future end of Runway 17.

The configuration and dimensions of the hangar rows will accommodate 6/8 unit T-hangars, individual hangars, or a combination of both. The separation between hangar rows would be approximately 80 feet. This would allow unobstructed aircraft taxiing and the use of bi-fold hangar doors. Access taxiways (20 feet wide) would be located between each hangar row. Lease area located adjacent to the new general aviation apron will accommodate conventional hangars. The north GA Apron would be accessed from the parallel taxiway; vehicle access to the apron and auto

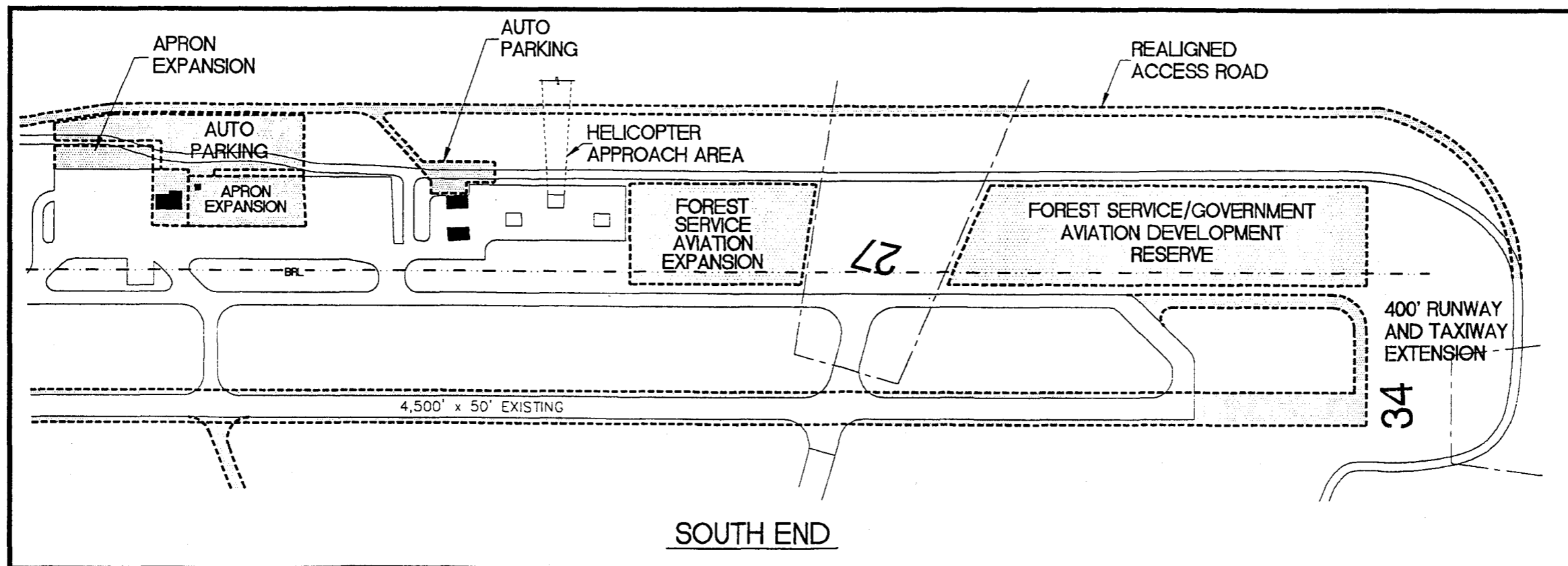
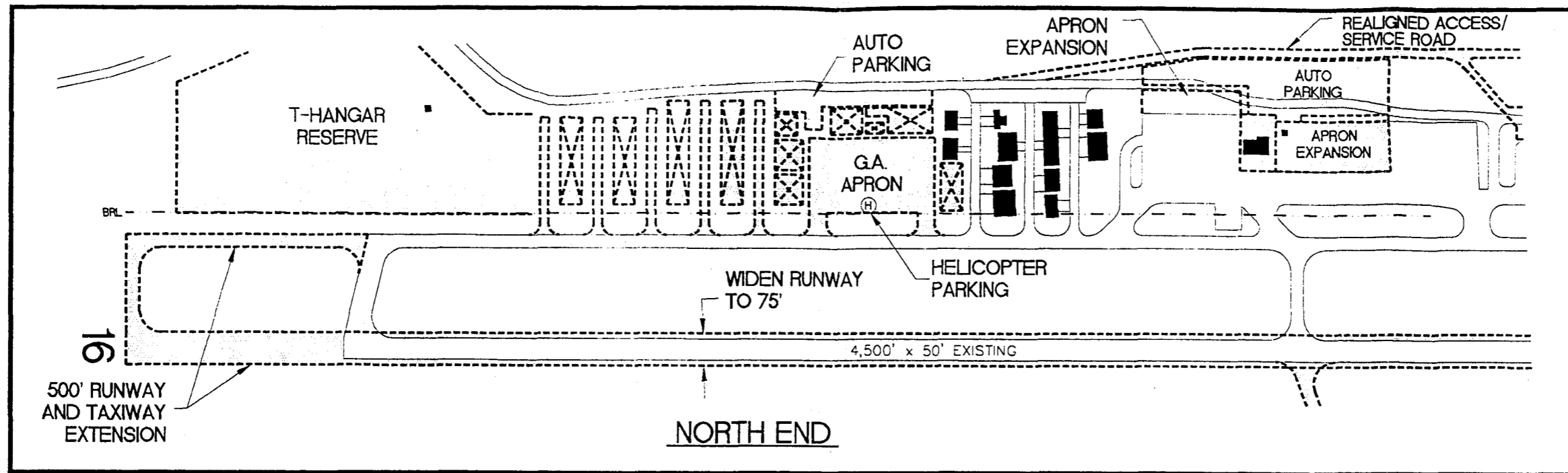
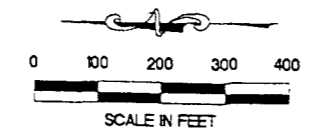

FIGURE 5-2
 JOHN DAY STATE AIRPORT
 LANDSIDE DEVELOPMENT
 CONCEPT #1

devco engineering inc.
 Corvallis Oregon
 (503) 757-8891

David Miller and Associates
 Aviation Planning Consultants



parking would be provided from the airport access road.

The concept also includes an expansion and reconfiguration of the main apron and auto parking areas in conjunction with the realignment of the airport access roadway (West Bench Access). Additional aircraft tiedown area would be provided directly east of the tiedown row located between the main apron and the Forest Service Apron. The airport's ability to accommodate potential expansion of government aviation operations is considered a primary facility need. The land area located south of the Forest Service helipads, east of Runway 17-35, extending south to the end of Runway 35, is identified as a Government Aviation Reserve. Development in this area will be compatible with existing government aviation operations and will also maintain a high degree of physical separation with general aviation. The land area within the runway protection zone for Runway 27 will not be developed in order to protect a unobstructed approach.

The realignment of the West Bench Access Road east of its current alignment is necessary to provide improved clearance between the roadway and existing helicopter landing areas. The new roadway section would be approximately 3,500 feet long. The realignment would begin 500 to 600 feet north of the airport terminal building with the roadway shifting 80 to 100 feet east of the current alignment. Based on the natural slope of the terrain, the new roadway will be considerably lower than the current roadway and be cut into the hillside. Vehicle access to the forestry facilities and a new terminal area vehicle parking area will also be required.

This development concept provides adequate land area to accommodate forecast demand for hangar space through the twenty year planning period, and beyond. Potential long term demands beyond the current planning period can be accommodated through development reserves.

The primary changes from the previous ALP layout are the provisions for accommodating expanded government aviation facilities along the southeast side of Runway 17-35, and a reconfiguration of aircraft parking apron. The main apron would be reconfigured to accommodate fixed- and rotor-wing aircraft parking and aircraft fueling.

LANDSIDE DEVELOPMENT CONCEPT #2

Concept #2 (Figure 5-3) is similar to the first concept with physical separation being provided between general aviation facilities (apron, tiedowns and hangars) and government forestry-related aviation development. The realigned West Bench access road described in Concept #1 is retained. In Concept #2, the expansion of the north general aviation area maintains the configuration of the existing hangar rows, providing three new hangar rows immediately beyond the last existing hangar row. A new general aviation apron and auto parking area would be located directly to the north

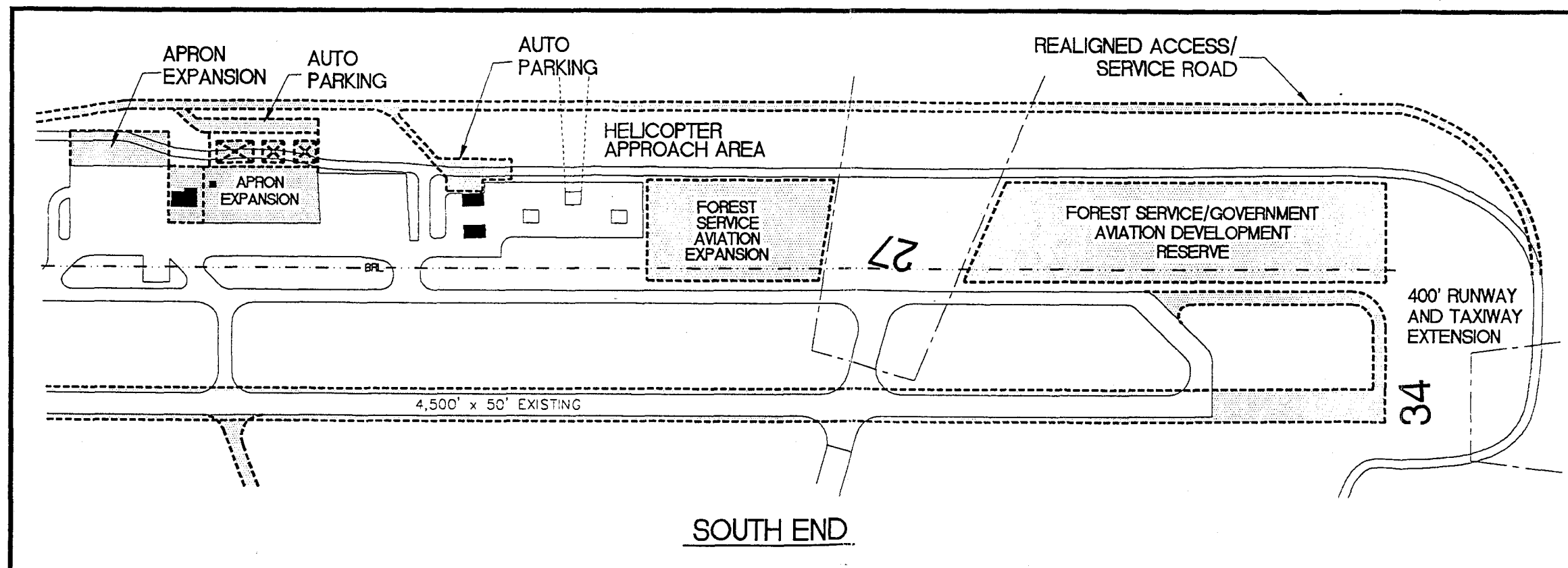
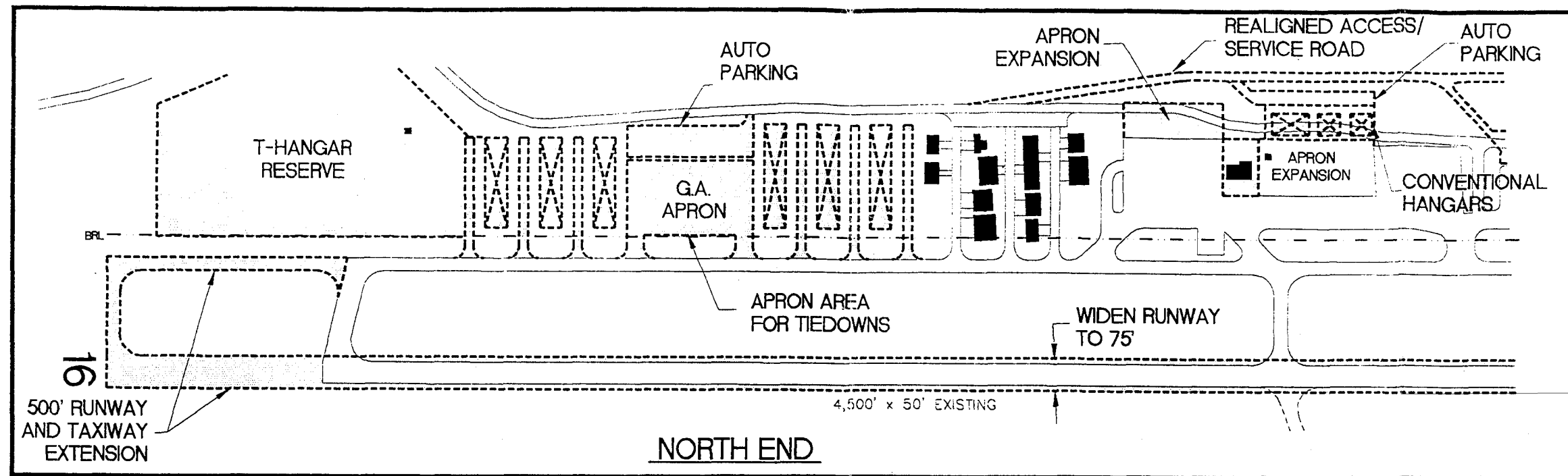

FIGURE 5-3
 JOHN DAY STATE AIRPORT
 LANDSIDE DEVELOPMENT
 CONCEPT #2

of the third new hangar row. Three additional hangar rows would be located north of the GA apron to accommodate intermediate demands and a hangar development reserve extending to the north end of the runway is designated for long term demand.

The reconfiguration of the main apron in Concept #2 is approximately the same size as Concept #1, but also incorporates an area capable of accommodating two or three conventional hangars at the east side of the apron located between the terminal building and Forest Service facilities. The compromise with this configuration would be a loss of light aircraft tiedowns and a smaller auto parking area. As a result, the new northern GA apron will be configured to accommodate aircraft tiedowns and auto parking.

The configuration and dimensions of the hangar and apron areas are roughly comparable to those outlined in Concept #1. As with Concept #1, this option will provide adequate land area to accommodate forecast demand for hangar space and aircraft parking through the twenty year planning period, and beyond.

PREFERRED DEVELOPMENT ALTERNATIVE (Landside Development Concept #3)

The review of the preliminary development concepts provided substantial information which was used to create a major component of the preferred development alternative. Landside Development Concept #3 (Figure 5-4) reflects elements of both preliminary concepts, accommodates the projected facility requirements, and provides an efficient development scenario which may be implemented gradually as demand and funding dictate. Further refinement of Concept #3 (Concepts 3A and 3B) was conducted based on current interest by prospective tenants in constructing aircraft hangars in the short term. The refined hangar layouts were then submitted to the local Airport Commission to evaluate and identify a preference, based on their understanding of the current demand for ground leases. Subsequent refinements to the facility layout contained in Concept #3B are depicted on the Airport Layout Plan (Drawing 1).

The configuration of the north general aviation development includes a single taxiway located immediately north the last existing hangar row, with an aircraft apron to be located immediately to the north. Initially, two individual taxiways may be constructed to provide access to the expanded hangar rows. As demand warrants, the new aircraft apron (6,950 square yards) would be constructed as an extension of the second taxiway. The landside areas abutting the new apron will accommodate six to seven conventional hangars. Due to the taxiing requirements of the larger aircraft, the new apron will not accommodate light aircraft tiedowns. East-west hangar rows will

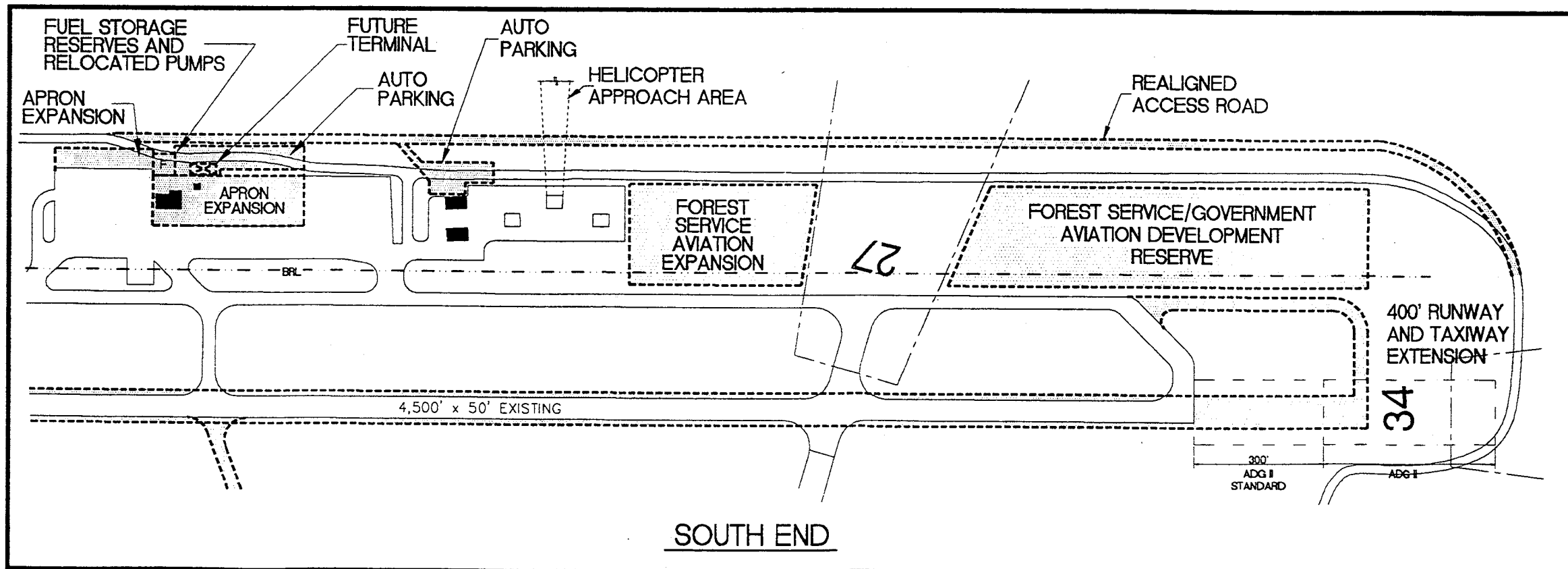
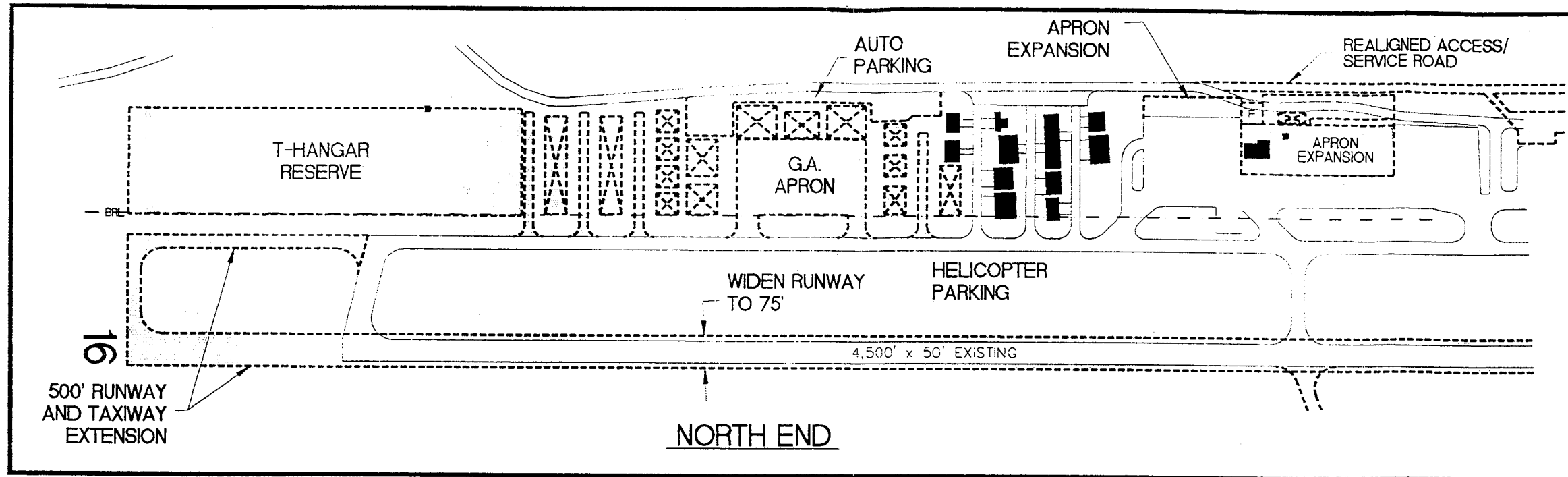

FIGURE 5-4
 JOHN DAY STATE AIRPORT
 LANDSIDE DEVELOPMENT
 CONCEPT #3

continue north of the apron, with additional reserve areas extending to the future end of Runway 17. An additional aircraft tiedown area (6,000-7,000 square yards) will be required to meet forecast demand during the current planning period. Additional parking requirements may also be integrated into the long-term development reserves. Auto parking will be provided adjacent to the hangar areas and apron.

The refined version of Concept #3 includes a reconfigured and reconstructed main apron. Relocation of the existing terminal building approximately 100 feet east of its current location is recommended as part of the apron reconfiguration. The terminal building relocation would be done in conjunction with (or following) the realignment of the West Bench Access Road. Another future project is the relocation of the aircraft fueling area from its present location to a more central location on the main apron. The existing underground fuel storage tanks will eventually be replaced with above-ground tanks; a fuel storage reserve is located east of the apron. Expanding aircraft parking on the main apron has limited potential due to space limitations.

The undeveloped area located between the terminal building and the Forest Service apron can accommodate approximately 6,000 square yards of tiedown area. The existing single row of tail-in tiedown positions would be reconfigured and the expanded southern portion of the main apron would be capable of accommodate approximately 15 tiedowns. With additional tiedowns provided at the southern end of the main apron, the northern end could be reconfigured to accommodate three business aircraft parking positions (50 feet wide) with drive-through parking. Four or five light aircraft tiedowns can be retained at the eastern edge of the apron. Itinerant helicopter parking would be accommodated between the apron and the parallel taxiway. With the full expansion and reconfiguration, the main apron will be able to accommodate 20 aircraft tiedowns, 3 business aircraft parking positions, and two itinerant helicopter parking positions. Based on forecast activity, additional aircraft tiedown areas will be required during the current planning period. A separate aircraft tiedown area, approximately 6,000 square yards, will be incorporated into the north general aviation development.

As part of the main apron reconfiguration and realignment of the West Bench Access Road, a new vehicle parking area will be needed in the terminal area. Existing vehicle parking in the terminal area is considered inadequate; the relocation of the terminal building will further reduce available parking. The area located between the main apron and the realigned access road has adequate space to accommodate 30 to 40 vehicle positions. Due to the sloping terrain, the access roadway, vehicle parking area, and apron will be a different elevations. The parking area may need to be terraced, with a pedestrian stairway provided to reach apron level. Some interest has also been expressed in providing parking positions and power hook-ups for recreational vehicles used by some seasonal forestry personnel. With the need for a new parking area, an opportunity exists for the airport to provide a broader range of services for users while possibly enhancing airport revenues in the

process. Vehicle access to the main apron for aircraft loading and unloading would be provided adjacent to the relocated terminal building.

The government forestry-related aviation reserves located along the southeastern side of Runway 17-35 consist of more than 300,000 square feet of land area divided into two sections. The facility needs in this area would be determined by the tenant. A primary consideration in this area is protecting the approach to Runway 27.

Opinions of engineering costs for individual projects recommended in the twenty-year planning period are included in the Capital Improvement Program, in Chapter Six. As noted in the previous chapter, facilities planned for John Day State Airport should initially be designed in accordance with FAA Airport Design Group (ADG) I standards and upgraded to ADG II standards later in the planning period.

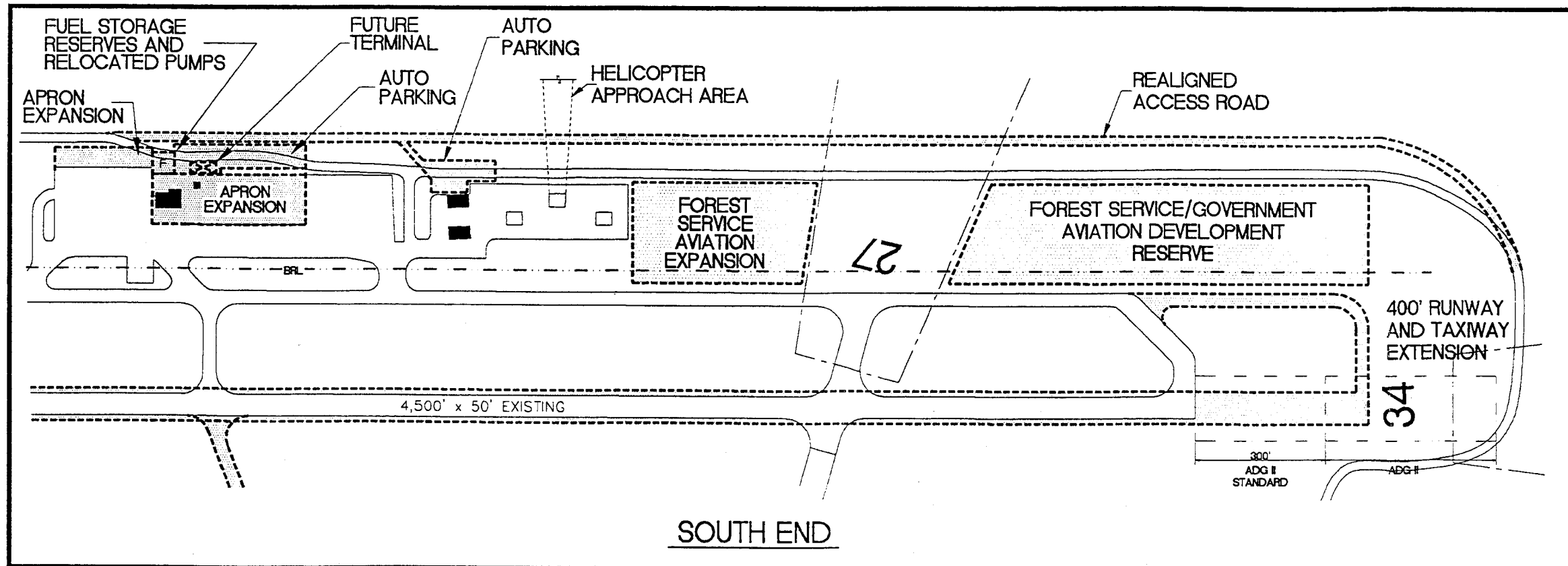
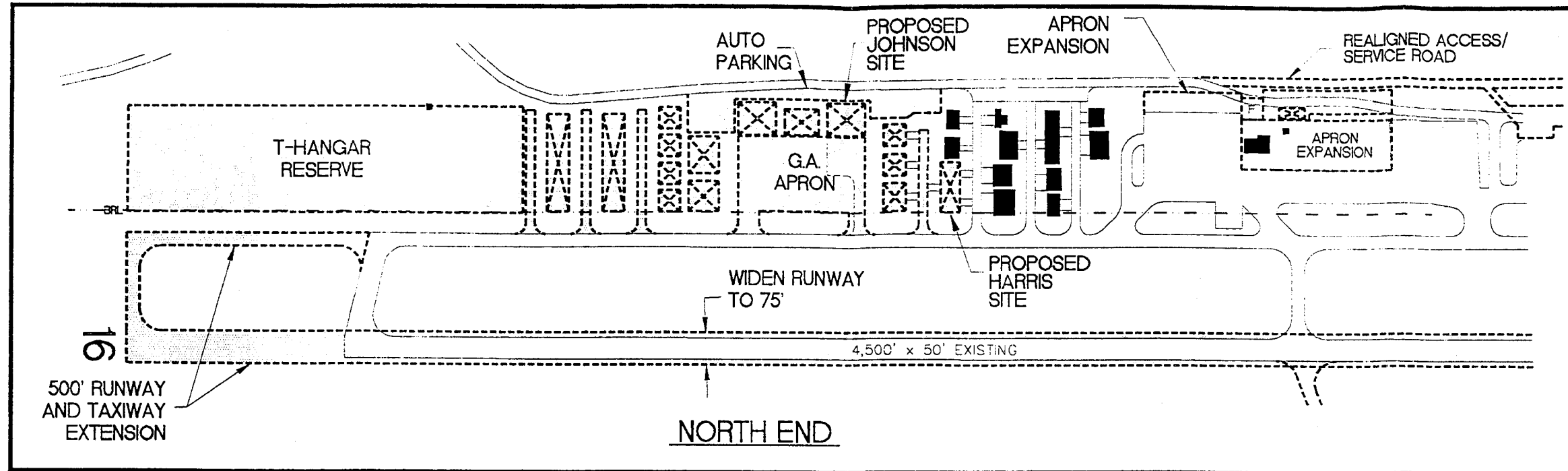

FIGURE 5-5
 JOHN DAY STATE AIRPORT
 LANDSIDE DEVELOPMENT
 CONCEPT #3A

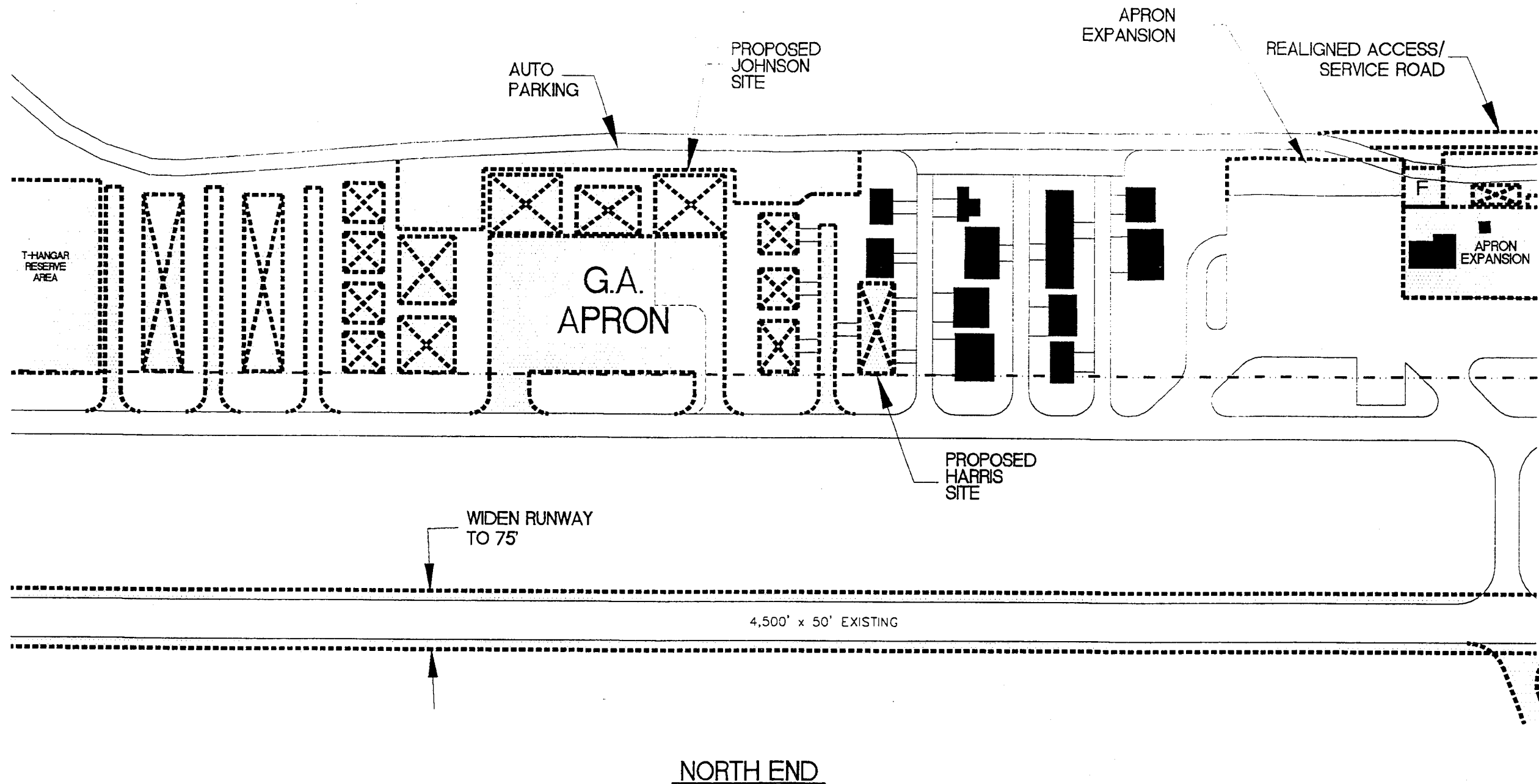

FIGURE 5-6

JOHN DAY STATE AIRPORT

GENERAL AVIATION DEVELOPMENT
CONCEPT #3A



David Miller and Associates
Aviation Planning Consultants

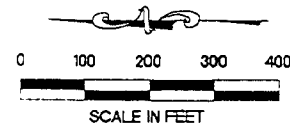

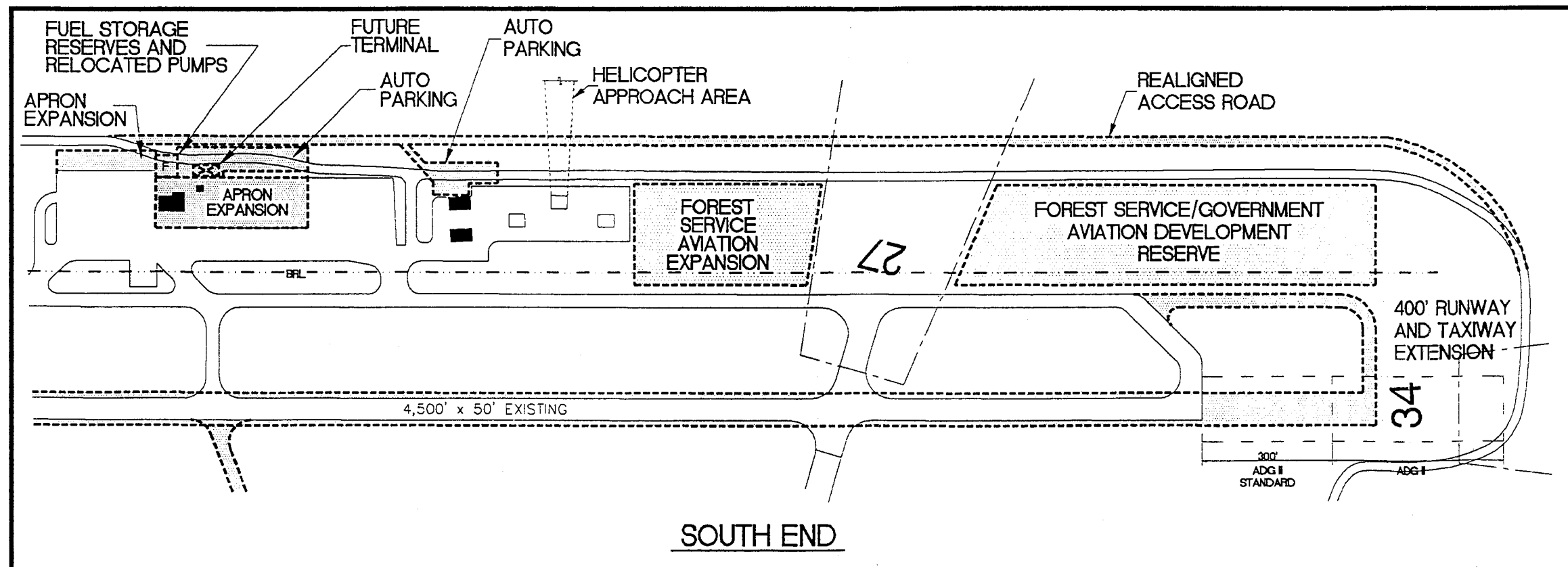
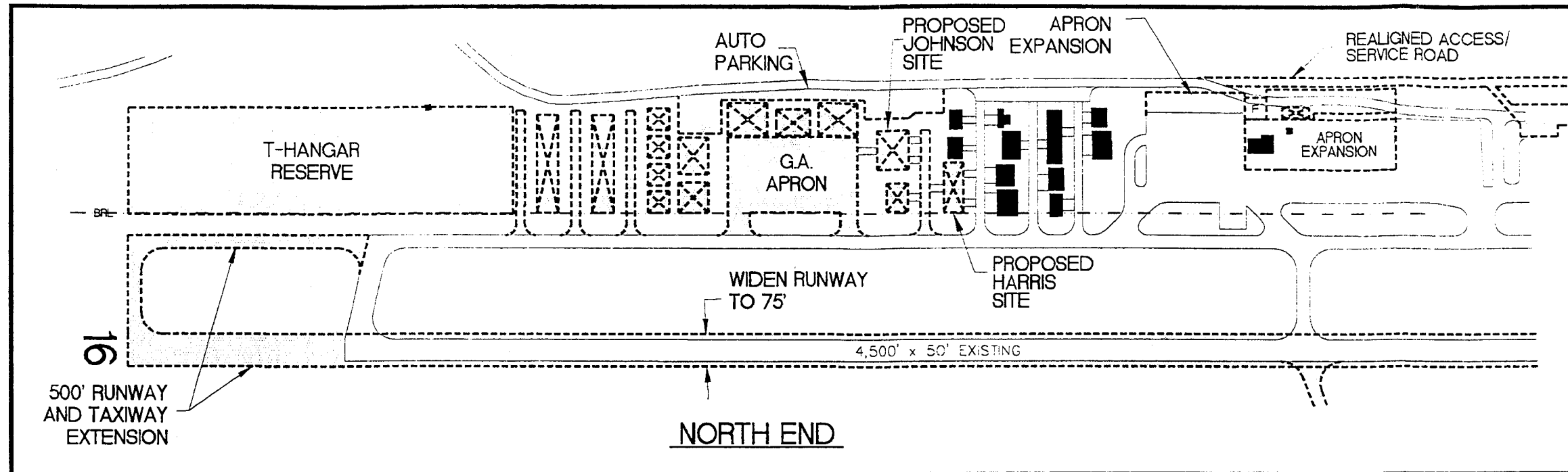
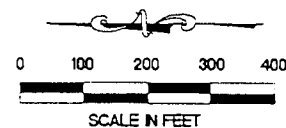

FIGURE 5-7
 JOHN DAY STATE AIRPORT
 LANDSIDE DEVELOPMENT
 CONCEPT #3B



David Miller and Associates
 Aviation Planning Consultants



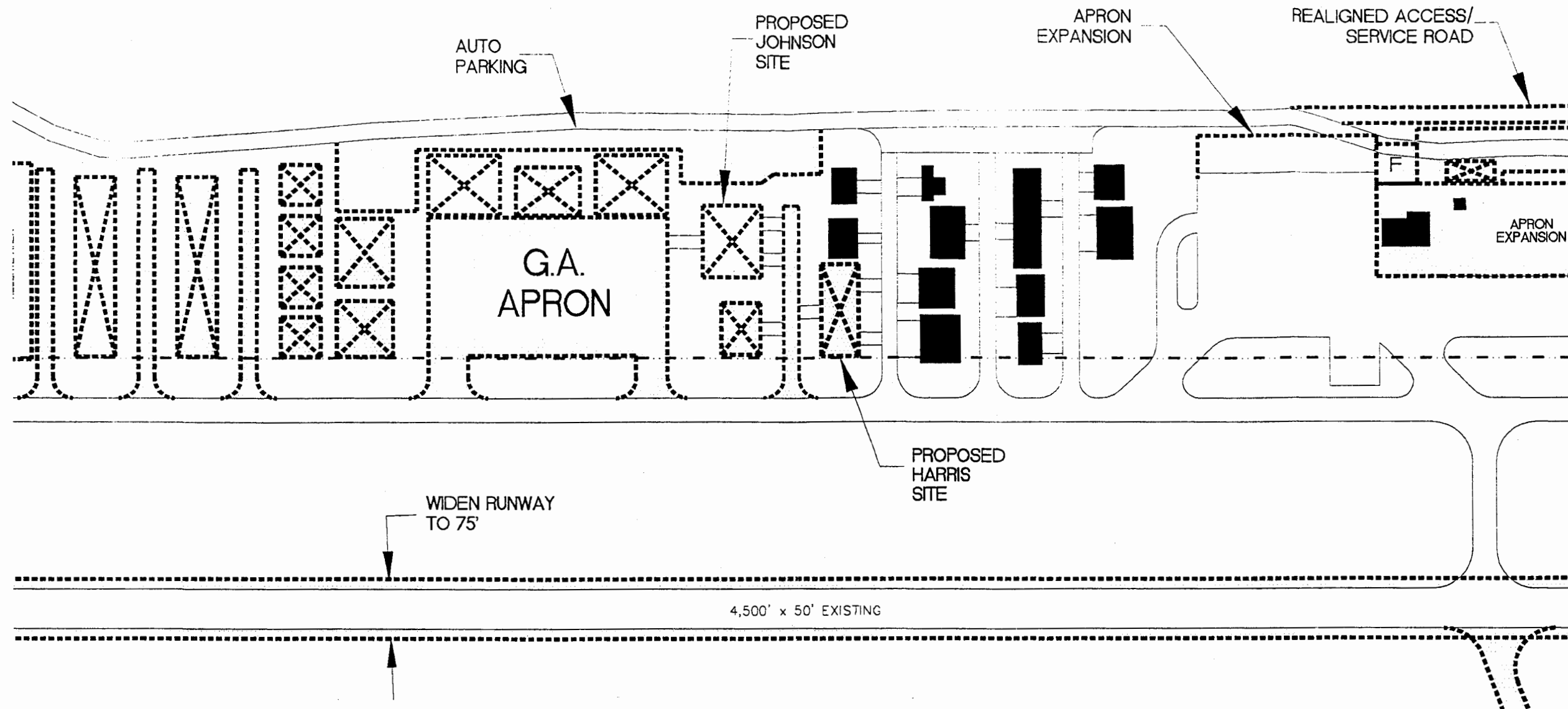

FIGURE 5-8
 JOHN DAY STATE AIRPORT
 GENERAL AVIATION DEVELOPMENT
 CONCEPT #3B

AIRPORT LAYOUT PLAN DRAWINGS

In the Alternatives section, options were evaluated for the long-term development of John Day State Airport. This effort resulted in the selection by the Oregon DOT Aeronautics and the John Day Airport Commission of the Preferred Alternative. The purpose of this section is to describe in narrative and graphic form, the recommended development through the 20-year planning period. A set of plans, referred to in the aggregate as the **Airport Layout Plans**, has been prepared to graphically depict recommendations for airfield layout, land use, and the identification and possible disposition of obstructions in the runway protection zones (RPZs) or approach surfaces. This set of plans, prepared pursuant to guidelines established by the Federal Aviation Administration (FAA), includes:

- *Airport Layout Plan*
- *Part 77 Airspace Plan*
- *Land-Use Plan with 20-year Noise Contours*

AIRPORT LAYOUT PLAN

The Airport Layout Plan (ALP) presents the existing and ultimate airport layout and depicts the recommended improvements which will enable the airport to meet forecast aviation demand. Detailed airport and runway data are provided on the ALP to facilitate the interpretation of the planning recommendations. Runway and Airport Data tables provide additional information on existing conditions and dimensions. An enlarged view of the terminal area has also been provided on the ALP to provide additional detail within the terminal area.

The ALP shows a number of improvements for both the airside and landside areas of the airport. It should be noted that the improvements depicted on the ALP, reflect all major airfield developments recommended during the current 20-year planning period. Decisions made by the airport sponsor, regarding the actual scheduling of projects will be based on specific demand and the availability of funding.

As noted in the facility requirements analysis, the highest current priority at the airport involves the resurfacing/reconstruction of Runway 17-35. This project also includes widening the existing runway from 50 to 60 feet. The ALP depicts an ultimate width of 75 feet, in order to meet future ADG II standards. However, the initial reconstruction project will be limited to a 60-foot runway width. Once the project is completed, the sponsor may note in the revision block, that the existing width of Runway 17-35 has been increased to 60 feet.

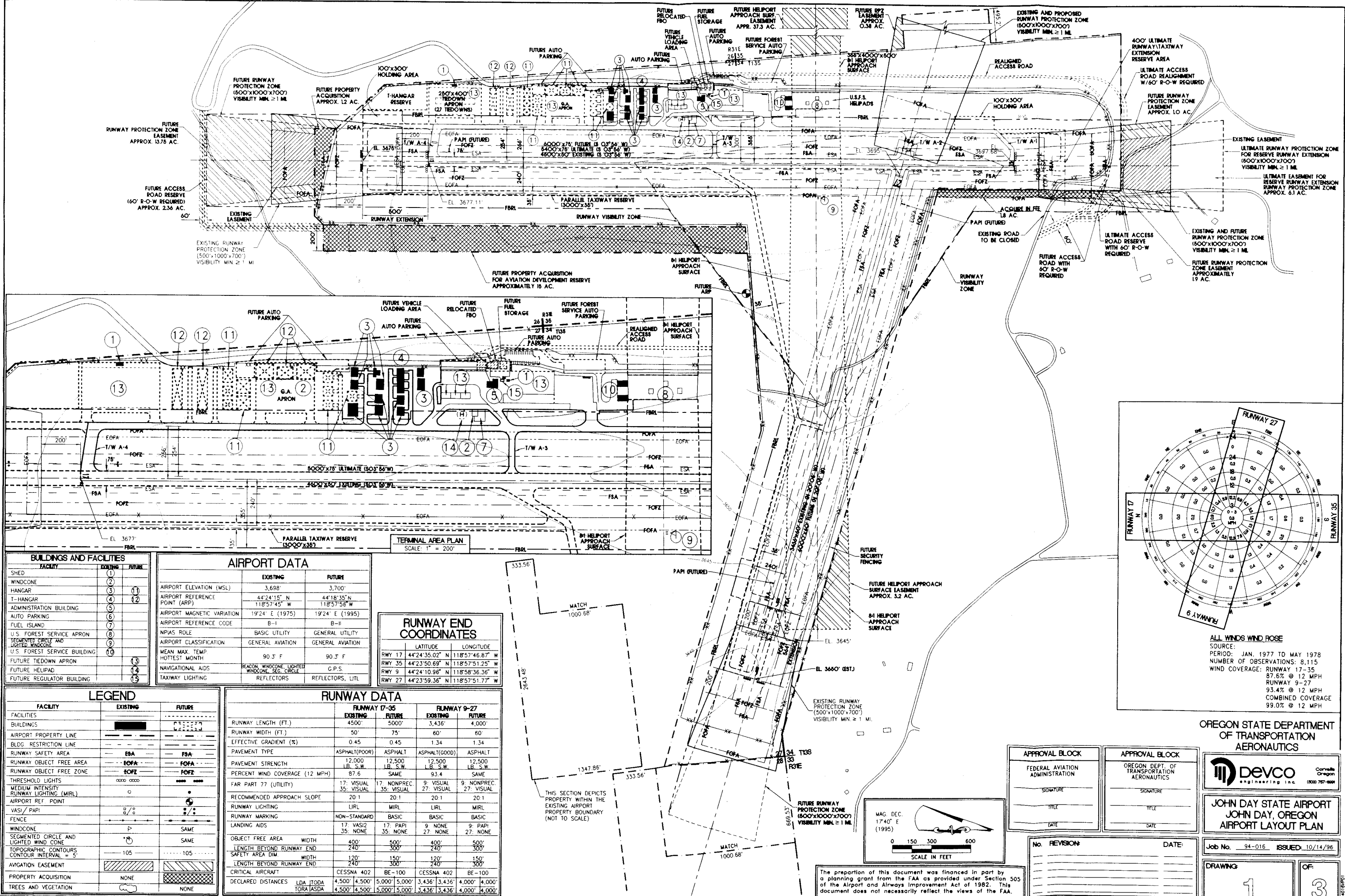

FACILITY	EXISTING	FUTURE
SHED	1	
WINDCONE	2	
HANGAR	3	11
T-HANGAR	4	12
ADMINISTRATION BUILDING	5	
AUTO PARKING	6	
FUEL ISLAND	7	
U.S. FOREST SERVICE APRON	8	
SEGMENTED CIRCLE AND LIGHTED WINDCONE	9	
U.S. FOREST SERVICE BUILDING	10	
FUTURE TIEDOWN APRON		13
FUTURE HELIPAD		14
FUTURE REGULATOR BUILDING		15

AIRPORT DATA		
	EXISTING	FUTURE
AIRPORT ELEVATION (MSL)	3,698'	3,700'
AIRPORT REFERENCE POINT (ARP)	44°24'15" N 118°57'45" W	44°18'35" N 118°57'56" W
AIRPORT MAGNETIC VARIATION	19°24' E (1975)	19°24' E (1995)
AIRPORT REFERENCE CODE	B-I	B-II
NPIAS ROLE	BASIC UTILITY	GENERAL UTILITY
AIRPORT CLASSIFICATION	GENERAL AVIATION	GENERAL AVIATION
MEAN MAX. TEMP	90.3° F	90.3° F
HOTTEST MONTH		
NAVIGATIONAL AIDS	BEACON, WINDCONE, LIGHTED WINDCONE, SEG. CIRCLE	G.P.S.
TAXIWAY LIGHTING	REFLECTORS	REFLECTORS, LITL

RUNWAY END COORDINATES			
	LATITUDE	LONGITUDE	
RWY 17	44°24'35.02" N	118°57'46.87" W	
RWY 35	44°23'50.69" N	118°57'51.25" W	
RWY 9	44°24'10.98" N	118°58'36.36" W	
RWY 27	44°23'59.36" N	118°57'51.77" W	

	RUNWAY 17-35		RUNWAY 9-27	
	EXISTING	FUTURE	EXISTING	FUTURE
RUNWAY LENGTH (FT.)	4500'	5000'	3,436'	4,000'
RUNWAY WIDTH (FT.)	50'	75'	60'	60'
EFFECTIVE GRADIENT (%)	0.45	0.45	1.34	1.34
PAVEMENT TYPE	ASPHALT(POOR)	ASPHALT	ASPHALT(GOOD)	ASPHALT
PAVEMENT STRENGTH	12,000 LB. S.W.	12,500 LB. S.W.	12,500 LB. S.W.	12,500 LB. S.W.
PERCENT WIND COVERAGE (12 MPH)	87.6	SAME	93.4	SAME
FAR PART 77 (UTILITY)	17: VISUAL 35: VISUAL	17: NONPREC. 35: VISUAL	9: VISUAL 27: VISUAL	9: NONPREC. 27: VISUAL
RECOMMENDED APPROACH SLOPE	20:1	20:1	20:1	20:1
RUNWAY LIGHTING	LIRL	MIRL	LIRL	MIRL
RUNWAY MARKING	NON-STANDARD	BASIC	BASIC	BASIC
LANDING AIDS	17: VASI2 35: NONE	17: PAPI 35: NONE	9: NONE 27: NONE	9: PAPI 27: NONE
OBJECT FREE AREA	WIDTH 400' LENGTH BEYOND RUNWAY END 240'	WIDTH 500' LENGTH BEYOND RUNWAY END 300'	WIDTH 400' LENGTH BEYOND RUNWAY END 240'	WIDTH 500' LENGTH BEYOND RUNWAY END 300'
SAFETY AREA DIM	WIDTH 120' LENGTH BEYOND RUNWAY END 240'	WIDTH 150' LENGTH BEYOND RUNWAY END 300'	WIDTH 120' LENGTH BEYOND RUNWAY END 240'	WIDTH 150' LENGTH BEYOND RUNWAY END 300'
CRITICAL AIRCRAFT	CESSNA 402	BE-100	CESSNA 402	BE-100
DECLARED DISTANCES	LDA 4,500' TORA 4,500'	LDA 5,000' TORA 5,000'	LDA 3,436' TORA 3,436'	LDA 4,000' TORA 4,000'

LEGEND		
FACILITY	EXISTING	FUTURE
FACILITIES		
BUILDINGS	■	▨
AIRPORT PROPERTY LINE	—	---
BLDG RESTRICTION LINE	---	---
RUNWAY SAFETY AREA	ESA	FSA
RUNWAY OBJECT FREE AREA	EOFA	FOFA
RUNWAY OBJECT FREE ZONE	FOFZ	FOFZ
THRESHOLD LIGHTS	○○○○	○○○○
MEDIUM INTENSITY RUNWAY LIGHTING (MIRL)	○	○
AIRPORT REF. POINT	●	●
VASI / PAPI	8/0	8/0
FENCE	—	—
WINDCONE	P	SAME
SEGMENTED CIRCLE AND LIGHTED WINDCONE	⊙	SAME
TOPOGRAPHIC CONTOURS	105	105
AVIGATION EASEMENT	▨	▨
PROPERTY ACQUISITION	NONE	▨
TREES AND VEGETATION	○	NONE

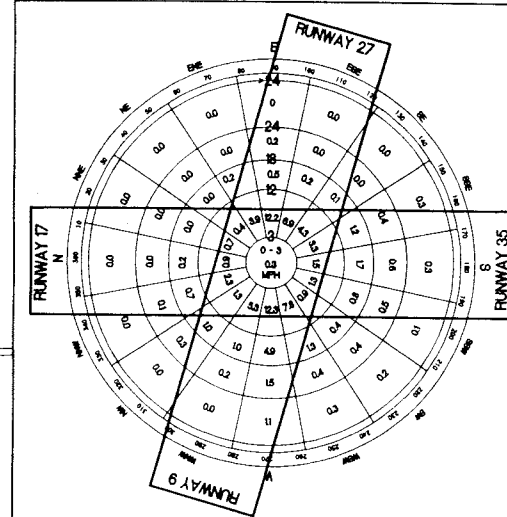

ALL WINDS WIND ROSE
 SOURCE:
 PERIOD: JAN. 1977 TO MAY 1978
 NUMBER OF OBSERVATIONS: 8,115
 WIND COVERAGE: RUNWAY 17-35
 87.6% @ 12 MPH
 RUNWAY 9-27
 93.4% @ 12 MPH
 COMBINED COVERAGE
 99.0% @ 12 MPH

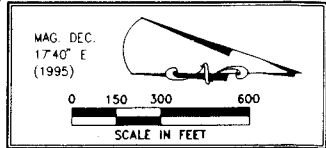

APPROVAL BLOCK FEDERAL AVIATION ADMINISTRATION SIGNATURE _____ TITLE _____ DATE _____	APPROVAL BLOCK OREGON DEPT. OF TRANSPORTATION AERONAUTICS SIGNATURE _____ TITLE _____ DATE _____
No. REVISION: _____ _____ _____	DATE: _____ _____ _____

OREGON STATE DEPARTMENT OF TRANSPORTATION AERONAUTICS

devco engineering inc. (503) 787-8000

JOHN DAY STATE AIRPORT JOHN DAY, OREGON AIRPORT LAYOUT PLAN

Job No. 94-016 ISSUED: 10/14/96

DRAWING **1** OF **3**

The preparation of this document was financed in part by a planning grant from the FAA as provided under Section 505 of the Airport and Airways Improvement Act of 1982. This document does not necessarily reflect the views of the FAA.

Beyond the reconstruction of Runway 17-35, the primary airside improvements include a 500-foot extension at north end of Runway 17-35, which will extend the runway and parallel taxiway to 5,000 feet. The extension of the primary runway will permit the airport to accommodate a wider range of general aviation aircraft under most conditions. A 564-foot extension is also depicted at the west end of Runway 9-27, to increase the length of the crosswind runway to 4,000 feet. Precision approach path indicators (PAPI) runway end identifier lighting (REIL) are recommended for Runways 17 and 9. The existing VASI on Runway 17 will be replaced at the end of its useful life.

The ALP depicts recommended taxiway improvements for Runway 9-27. Ultimately, a 35-foot taxiway would extend from the existing midfield exit taxiway on Runway 17-35, to the approximate mid-point of Runway 9-27, then extend to the end of Runway 9, as a parallel taxiway. A 3,600-foot taxiway section is required to reach the existing end of Runway 9; an additional 564-foot section would be required to reach the future end of Runway 9. In the event that funding is not available to construct the entire taxiway in a single project, the first priority would be to reach the midpoint of Runway 9-27, with the parallel sections added later. By providing the initial taxiway section, the need for aircraft to back-taxiway along the runway would be significantly reduced.

The Main Apron is identified for reconfiguration and expansion, with the airport operations building and fuel storage facilities to be relocated further east, in order to maximize use of the apron area. The realignment of the West Bench access road will permit the facility relocation and construction of additional auto parking in the terminal area. The remaining undeveloped area located south of the existing apron would be developed to provide a continuous apron, combining with the existing Main Apron and the existing narrow strip of tiedowns. Reconfiguration of the Main Apron will include light aircraft tiedowns, corporate transient parking, and rotorcraft parking.

The north GA area appears to be capable of accommodating aircraft hangars and parking through the planning period. Individual hangar rows will be accessed by 250- to 300-foot access taxilanes which will extend from the parallel taxiway. A new general aviation apron has been planned to provide area for aircraft access and short-term parking adjacent to conventional hangars to be located around the north, south, and east edge of the apron. There will be no light aircraft tiedowns provided in this area. The construction of the new north apron, in conjunction with the reconfiguration of the Main Apron, will provide improved efficiency and additional apron capacity for all aircraft types. Existing vehicle parking areas will be expanded in the areas adjacent to the new hangar and apron areas and in the terminal area along the airport access road.

As noted in the facility requirements analyses, Runway 17 has been identified for accommodating a future nonprecision instrument approach. Based on this need, additional clearance will be required between the runway and future development. As a result, the building restriction line for the runway is being changed to 355 feet, which will provide adequate obstruction clearance for the

runway/taxiway system and the runway transitional surface. The relocated BRL will slightly reduce the total area available for development. The ALP identifies the entire area located along the east side of Runway 17-35, north of the main apron, for future hangar and tiedown areas.

Although the demand for general aviation landside facilities is expected to met on the northeast side of Runway 17-35 through the 20-year planning period, and beyond, it would be prudent to identify undeveloped areas which may be appropriate for aviation use.

An aviation development reserve (approximately 15 acres) has been identified for the area located along the west side of Runway 17-35, near its north end. The strip of privately-owned land approximately 200 feet wide and 3,200 feet long, is located adjacent to the airport's northwestern property line. The additional land area would be required to accommodate any future hangar or aircraft parking development on the west side of the runway. A parallel taxiway reserve is also identified (within existing airport property) to protect long-term access needs for the west side of the runway. Surface access to this area would be required, and would need to remain clear of the Runway 17 approach surface, extended runway safety area and object free area.

The area located on the east side of Runway 17-35, near the south end will be reserved to accommodate potential expansion of government aviation-related development. The reserve areas extend south from the existing helipads, to the runway protection zone for Runway 27; the reserve continues beyond the southern edge of the Runway 27 RPZ, within the West Bench access road.

A 3,300-foot realignment of the West Bench Road is depicted on the ALP. The primary purpose of the realignment is to provide adequate separation from existing aviation facilities, particularly the forestry helipads. The roadway should also be upgraded as needed, in order to meet normal design standards for public roadways. The West Bench Road has been identified as an alternative access route to the airport.

PART 77 AIRSPACE PLAN

The Part 77 Airspace Plan for John Day State Airport, depicted in **Drawing 2**, was developed based on Federal Aviation Regulations (FARs) **Part 77, Objects Affecting Navigable Airspace**. The plan provides the plan view of the ultimate imaginary surfaces for the airport and identifies the airspace and approaches to each runway end to protect them from encroachment by obstructions which would affect safe airport operations. By comparing the elevations of the imaginary surfaces with the surrounding terrain, obstructions to navigable airspace were identified. The surface heights, angles, and radii are determined by the runway type and instrumentation. The Airspace Plan reflects **Part 77** critical surfaces for the recommended airfield development and identifies those obstructions which

penetrate the surfaces.

None of the runway approaches (existing or future) at John Day State Airport are affected by terrain penetrations, however, a portion of the runway conical surface located beyond the approach surface for Runway 35, is penetrated by terrain.

Five obstructions are listed on the airspace plan including hangars located along the east side of Runway 17-35; terrain, two radio towers (also located within the area of terrain penetration); and the existing West Bench access roadway, which crosses the Runway 35 approach surface at its beginning. Items which have a location fixed by function (i.e. windsock, VASI, etc.) do not present significant obstructions. Buildings, towers, and other obstructions which cannot be easily moved or lowered, should be lighted.

The existing approach surface for the runways is based on visual approach capabilities with a slope of 20:1. Runways 17 and 9 have been identified as potential nonprecision instrument approaches. Both runways are included in the Utility category under FAR Part 77, therefore, based on current Part 77 standards, the existing 20:1 approach slope also applies to nonprecision instrument approach capabilities.

One significant addition to the updated airspace plan is the depiction of approach surfaces for the forestry helipads. The helipads are designated landing areas, and as a result, need to be protected with standard approach surfaces. The standard approach slope for a visual helipad is 8:1. As noted earlier, vehicles traveling on the existing West Bench Road, penetrate the east-side approach surface to the helipads. The recommended realignment of the roadway will eliminate any existing airspace conflicts.

The airspace plan reflects the runway system in its ultimate configuration, with Runway 17-35 at 5,000 feet, Runway 9-27 at 4,000 feet, and the forestry helipads in their present location.

Planning for the addition of a precision instrument approach for Runway 17 requires clearing a larger runway primary surface. The existing primary surface is 250 feet wide; this increases to 500 feet wide for runways with nonprecision approaches. As a result of this potential change, some obstructions which are currently in the runway transitional surface, may, in the future, be within the larger primary surface, and some existing hangars, which have not in the past, penetrated the transitional surface, now penetrate the surface.

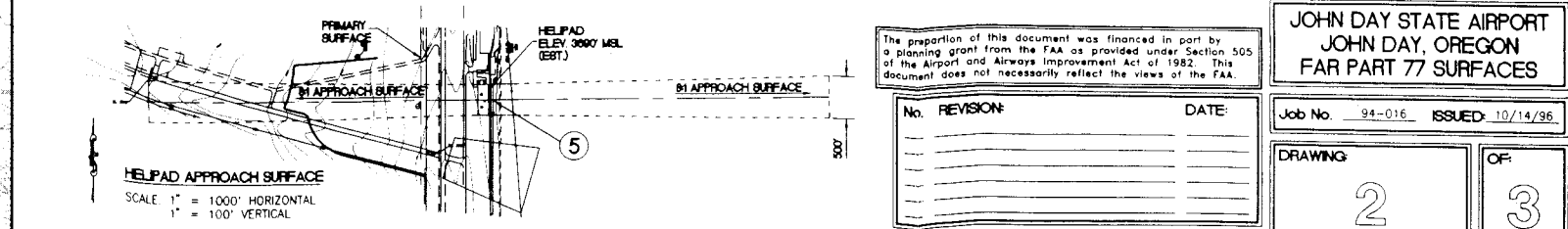
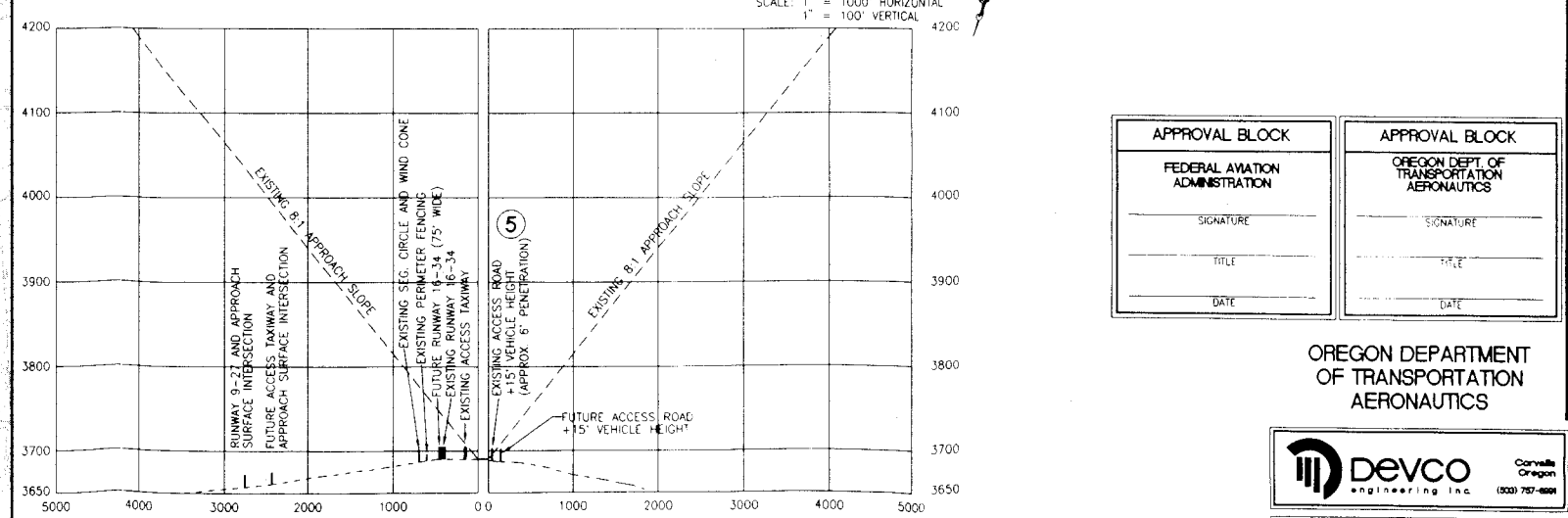
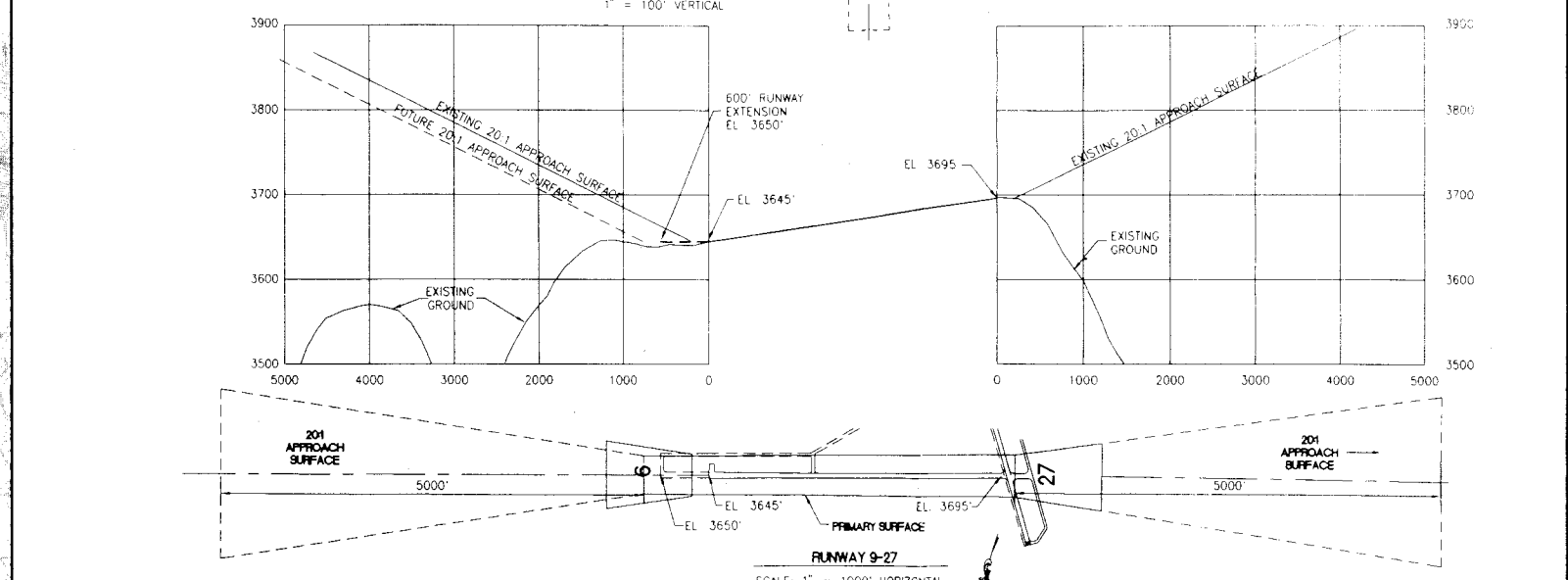
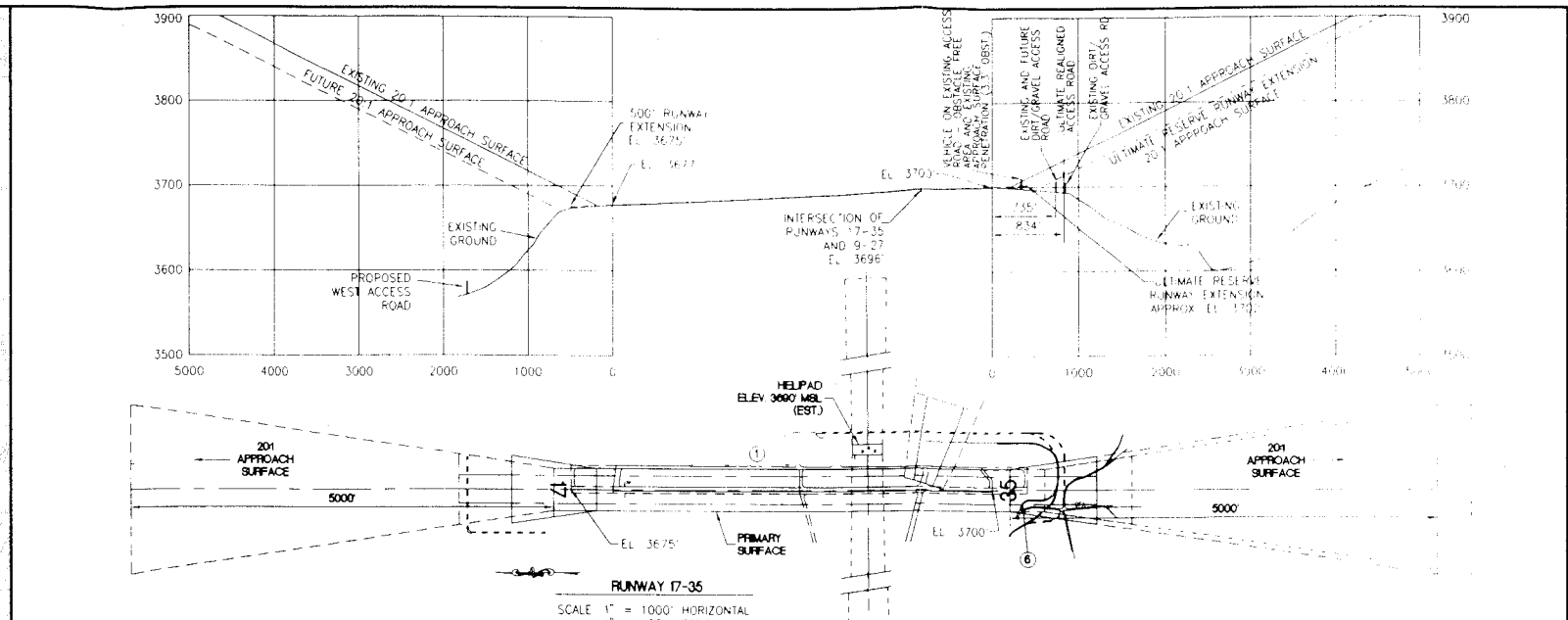
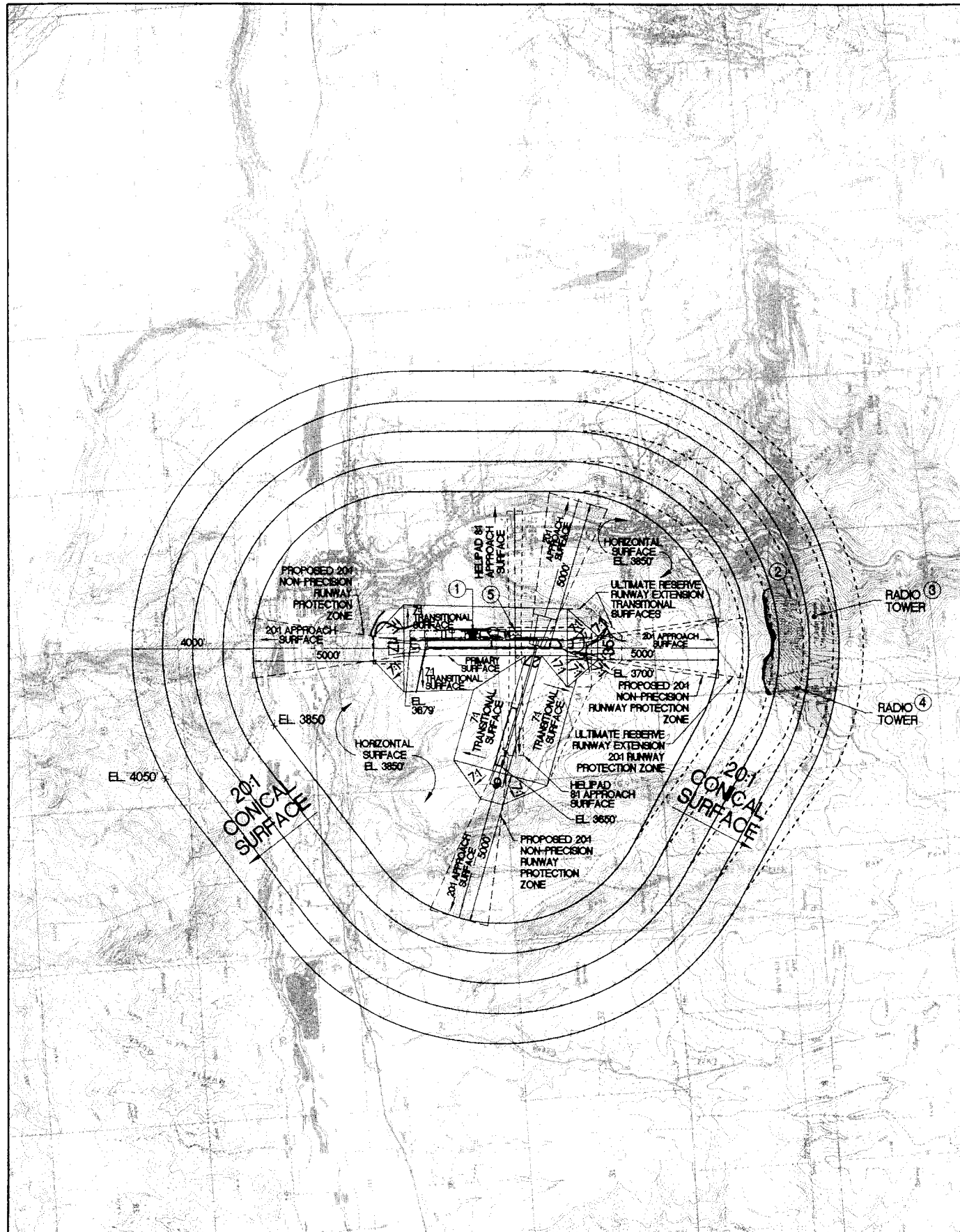

OBSTRUCTION TABLE				
ITEM NO.	DESCRIPTION	ELEVATION MSL	PENETRATION SURFACE	DISPOSITION
1	HANGARS	3700 (EST.)	12' TRANSITIONAL	LIGHT
2	TERRAIN	3600	VARIABLE CONICAL	NONE
3	RADIO TOWER	4307 (EST.)	100' (EST.) CONICAL	LIGHT
4	RADIO TOWER	4300 (EST.)	100' (EST.) CONICAL	LIGHT
5	VEHICLE ON EXISTING ACCESS ROADWAY	3708 (EST.)	8' (CONSIDERING 6' VEHICLE)	HELIPAD APPROACH SURFACE RELOCATION
6	VEHICLE ON ROADWAY	3707 (EST.)	3.3' OBSTACLE FREE AREA - Rwy 35 201 APPROACH SURFACE	ROAD RELOCATION

APPROVAL BLOCK	APPROVAL BLOCK
FEDERAL AVIATION ADMINISTRATION	OREGON DEPT. OF TRANSPORTATION AERONAUTICS
SIGNATURE _____	SIGNATURE _____
TITLE _____	TITLE _____
DATE _____	DATE _____

OREGON DEPARTMENT OF TRANSPORTATION AERONAUTICS



JOHN DAY STATE AIRPORT
JOHN DAY, OREGON
FAR PART 77 SURFACES

The preparation of this document was financed in part by a planning grant from the FAA as provided under Section 505 of the Airport and Airway Improvement Act of 1982. This document does not necessarily reflect the views of the FAA.

No. REVISION:	DATE:

Job No. 94-016 ISSUED: 10/14/96

DRAWING	OF
2	3

17/10/96 14:17

LAND-USE PLAN

The Airport Land-Use and Zoning Plan, **Drawing 3**, for John Day State Airport depicts existing zoning in the immediate vicinity of the airport, which is under the jurisdiction of the Cities of John Day and Canyon City, and Grant County. The airport is physically located within the urban growth boundary of the City of John Day, although Grant County zoning is in effect. The airport is zoned **AA (Airport)**; lands located immediately northwest to the airport are zoned **AA - Industrial**. The majority of the remaining lands immediately adjacent to the airport are zoned low density residential or recreational.

Airport Overlay Zoning has not been established for the airport. Overlay zoning is designed to protect the airspace surrounding an airport, by providing height and hazard guidance. Overlay zones are designed to provide height restrictions which are adequate to protect **FAR Part 77** airspace imaginary surfaces. Overlay zoning does not affect existing surface zoning. **Overlay zoning should be established at John Day State Airport. The boundaries of the overlay zone should coincide with the ultimate FAR Part 77 airspace surfaces depicted on Drawing No. 2 (Airspace Plan).**

The 20-year noise contours (2014) are depicted on the Land Use Plan to provide a general indication of long-term noise exposure. Due to the level of forecast operations, the noise contours for both current conditions and twenty years are relatively small, with the 65 Ldn contours contained almost entirely within airport property boundaries. A small portion of the 20-year 65 Ldn contour extends outside the southwest corner of the airport.

A small portion of the 20-year 60 Ldn contour extends beyond airport property along the southern edge of the airport (parallel to Runway 9-27); the southwest corner of the airport; and near the northeast corner of the airport.

Portions of the 20-year 55 Ldn contour extend beyond airport property along the northwest, northeast, and southwest corners of the airport; and beyond the airport property lines along both sides of Runway 9-27.

Based on FAA noise compatibility planning standards and existing zoning, no conflicts exist between airport noise and existing land use. All land uses are compatible with noise levels of 65 Ldn and lower. There are no residences or structures identified within the 55 Ldn contour or higher.

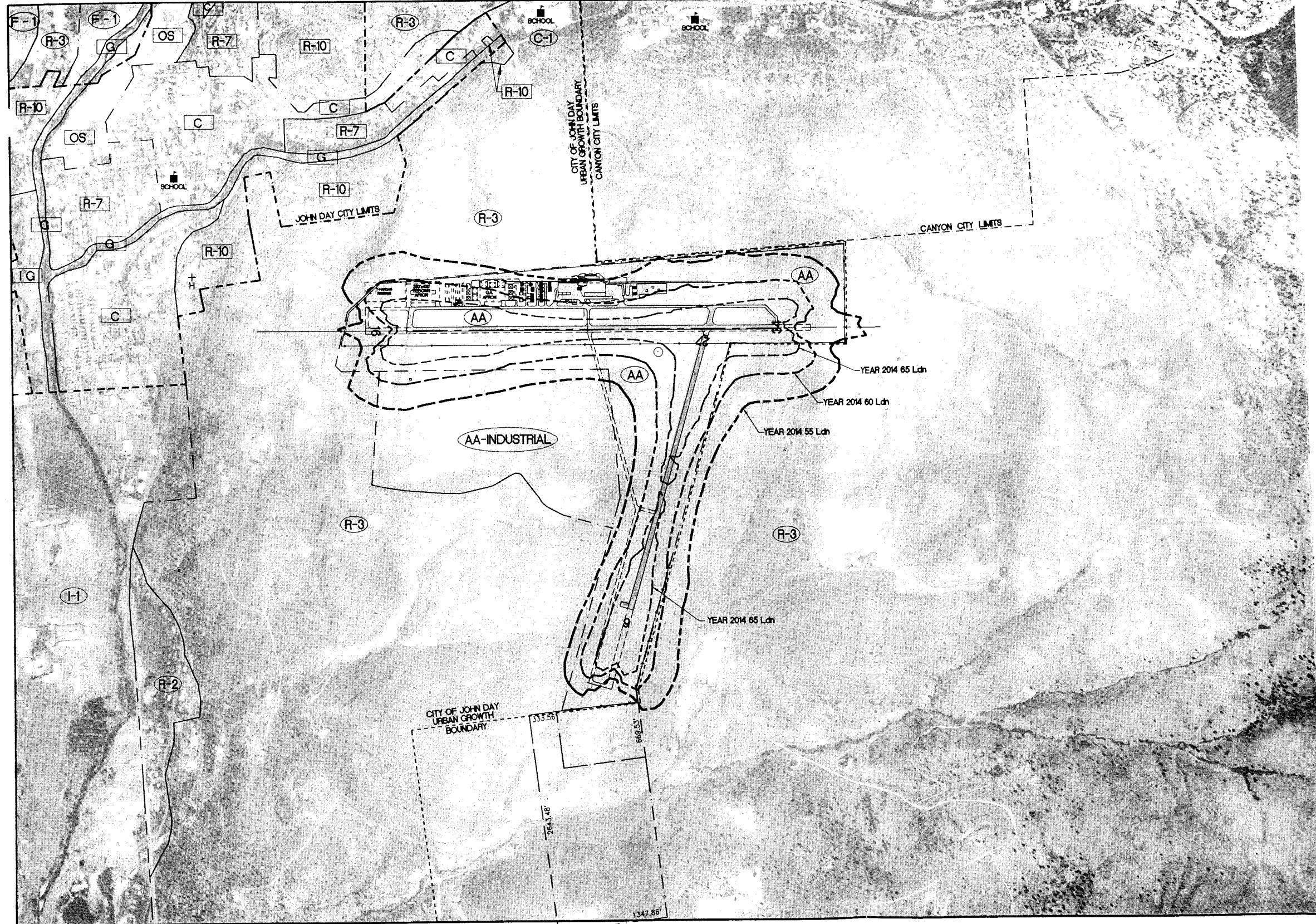

LEGEND

- YEAR 2014 55 Ldn CONTOUR
- YEAR 2014 60 Ldn CONTOUR
- YEAR 2014 65 Ldn CONTOUR
- AIRPORT PROPERTY LINE
- CITY LIMITS
- URBAN GROWTH BOUNDARY
- SCHOOL
- ⊕ HOSPITAL

GRANT COUNTY ZONING

- (A-A) AIRPORT
- (AA(IND)) AIRPORT INDUSTRIAL
- (C-1) COMMERCIAL
- (F-1) EXCLUSIVE FARM
- (I-1) INDUSTRIAL
- (R-2) RESIDENTIAL
- (R-3) RECREATIONAL

CITY OF JOHN DAY ZONING

- (OS) OPEN SPACE
- (G) GREENWAY
- (R-10) RESIDENTIAL
- (C) COMMERCIAL
- (IG) INDUSTRIAL - GENERAL

CANYON CITY IS ZONED RESIDENTIAL

T13S, R31E
SECTIONS:
27, 28, 34, 35
GRANT COUNTY,
OREGON

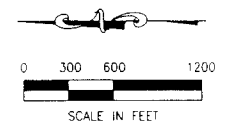

NOTE:
THE CITY OF JOHN DAY AND GRANT COUNTY ARE ENCOURAGED TO DEVELOP AND ESTABLISH AN AIRPORT VICINITY OVERLAY ZONE WHICH SHOULD BE DESIGNED TO GUIDE DEVELOPMENT AND LAND USES ON AND AROUND THE LAND SURROUNDING THE AIRPORT. THE ORDINANCE SHOULD INCLUDE HEIGHT RESTRICTIONS WHICH ARE INTENDED TO PROTECT FAR PART 77 AIRSPACE IMAGINARY SURFACES.

APPROVAL BLOCK FEDERAL AVIATION ADMINISTRATION _____ SIGNATURE _____ TITLE _____ DATE	APPROVAL BLOCK OREGON DEPT. OF TRANSPORTATION AERONAUTICS _____ SIGNATURE _____ TITLE _____ DATE
--	--

The preparation of this document was financed in part by a planning grant from the FAA as provided under Section 505 of the Airport and Airways Improvement Act of 1982. This document does not necessarily reflect the views of the FAA.

OREGON DEPARTMENT
OF TRANSPORTATION
AERONAUTICS



**JOHN DAY STATE AIRPORT
LAND USE PLAN AND
NOISE CONTOURS**

No. REVISION:	DATE:

Job No. 94-016 ISSUED: 10/14/96

DRAWING:	OF:
3	3

Airport Layout Plan Report

for

**John Day State Airport
John Day, Oregon**

prepared for the

**Oregon Department of Transportation
Aeronautics**

and

Grant County Airport Commission

Chapter Six

CAPITAL IMPROVEMENT PROGRAM

The previous chapters in the Airport Layout Plan Report have established the facility needs and recommended plans for John Day State Airport through the twenty-year planning period. The purpose of this chapter is to provide an implementation program by which the recommendations can be realized in an effective and economical manner. The following sections present development schedules and construction cost summaries for the development projects and financing options for capital improvements.

The cost of providing needed facilities at the airport will not be borne solely by the Oregon DOT Aeronautics. Several sources for development funding exist, including the Federal Aviation Administration (FAA), the local community (i.e. Grant County), and private enterprise. As proposed, ODOT Aeronautics and the local community would each be responsible for providing approximately 5 percent of the total development cost during the planning period. Hangar development on the airport is anticipated to continue being privately funded.

The primary source for airport development funding is aviation users, both locally and nationally. Typically, FAA grants fund 90 percent of eligible projects at airports such as John Day State Airport. These grant funds are derived from user fees deposited in the National Aviation Trust Fund. Since 1982, the federal **Airport Improvement Program (AIP)** has been the legislation authorizing the dissemination and use of these funds. The funds are collected through excise taxes on airline tickets, aviation fuel, accessories, aircraft registrations, and other aviation uses. The fate of the present Airport Improvement Program is uncertain in the current Congress. Funding levels have been cut for several consecutive years, while demand for funds continues to increase. The result has been that many badly needed airport improvement projects have been deferred indefinitely,

particularly at smaller airports. It is difficult to predict what changes in funding may occur until the issue is fully addressed. However, for planning purposes, it is assumed that the current level of federal funding eligibility will continue during the twenty year planning period.

AIRPORT DEVELOPMENT SCHEDULES AND COST SUMMARIES

Prior to formulation of the development schedules, the cost of each proposed improvement has been estimated. The figures used for all development items throughout the planning period are expressed in 1995 dollars and include 25 percent overhead for administration, engineering, and contingencies. For future implementation of this plan, airport management can convert the 1995-based figures by adjusting for subsequent inflation. The interim change in the **United States Consumer Price Index (USCPI)** can be used to estimate future costs by using the following formula to yield a multiplier ratio:

$$\frac{X}{151.9} = Y$$

Where:

X	=	USCPI in any given future year
151.9	=	USCPI in April 1995 (1982-84 = 100)
Y	=	Conversion factor

Dividing the future **CPI** by the 1995 **CPI** provides a conversion factor (Y) which, in turn, is multiplied by the 1995-based cost estimates to provide appropriate amounts in any future re-evaluation. Only national **CPI** data should be used, as local or regional indices may vary. Consumer Price Index information may be obtained from the U.S. Bureau of Labor Statistics and the economic research units of most commercial banks and councils of governments.

The following sections outline the recommended development program and detailed funding distribution assumptions. The scheduling has been prepared in accordance with facility requirements determined earlier, as well as with economic feasibility. It should be remembered that, in addition to funding considerations, airport development should take place in response to demonstrated demands or actual activity, rather than according to a fixed time frame corresponding to forecasts of future activity. Therefore, should significant variations from forecast trends occur, facility development scheduling may have to be adjusted in the future.

The prioritized schedules have been divided into two stages--Short Term and Long Term--covering the entire planning period. Table 6-1 shows that the total cost of developing John Day State Airport to meet forecast needs will total approximately \$6,608,250 by the year 2014.

SHORT TERM DEVELOPMENT

[Note: The airport had a major facility upgrade completed in 1996. Runway 17-35 and the parallel taxiway were reconstructed to meet ADG I standards; medium intensity runway edge lighting (MIRL) was also installed. The main apron was reconstructed and expanded; Runway 9-27 had crackfilling, drainage repair, and a sealcoat completed; and game fencing (76" high) was installed around the airport perimeter. As a result of these improvements, the majority of the short term development projects identified in Table 6-1 have been completed. As funds become available, the remaining projects (short and long term) may be undertaken.]

Short term projects comprise the initial five years of the planning period and reflect immediate airport needs. Due to the cost of the most pressing improvements, only five projects are identified for the first five year period. Three of the five projects involve major reconstruction of pavement surfaces (runway, taxiway, and apron) which have significantly deteriorated. A fourth project is urgently needed to protect the long-term viability of the crosswind runway pavement, and a fifth project is needed to facilitate private hangar development on the airport.

The highest capital improvement priority at the airport is the reconstruction, widening, and extension of Runway 17-35 to 5,000 by 60 feet. The condition of the runway continues to deteriorate as the width of transverse and longitudinal cracking has increased (up to 3 inches). Aggressive crackfilling has mitigated the problem slightly, but aircraft rolling down the runway experience substantial vibration. Without reconstruction, runway use may eventually need to be limited to light single engine aircraft use only, with a notice to airmen (NOTAM) issued regarding its condition.

The runway reconstruction project includes widening the runway to 60 feet from the existing 50 foot width in order to meet Airplane Design Group I design standards. Runway edge lighting will be relocated and upgraded to medium intensity (MIRL). A 500-foot extension to the runway would be located at the north end. The FAA-recommended lateral and extended runway safety area will also be incorporated into the runway reconstruction project. The ADG I standard for runway safety area is a width of 120 feet (centered on runway), extending 240 feet beyond runway end.

The second short term project is the construction of two 20 by 300-foot taxilanes in the north general aviation area. The taxilanes are needed to accommodate short-term plans to add new hangars on the area. The taxilanes will extend in an east-west direction from the Runway 17-35 parallel taxiway.

A Runway 9-27 crack-fill and sealcoat project with drainage repair work is identified as the third short term project for the airport. Although Runway 9-27 is in good condition, it is particularly important that this work be done on the runway before the surface is allowed to deteriorate. This project should be undertaken as soon as possible regardless of the sponsor's ability to secure funding for the Runway 17-35 reconstruction.

The condition of the parallel taxiway for Runway 17-35 is comparable to the runway. The fourth short term project is the reconstruction, resurfacing, and extension of the parallel taxiway. The taxiway should also be widened from 30 to 35 feet during the reconstruction in order to meet the future ADG II design standards. Based on the limited availability of funding, it is most practical to include the nominal widening as part of the current reconstruction project.

The final project included in the short term improvement group is the reconstruction of the main apron. The condition of the apron is comparable to Runway 17-35 and the parallel taxiway. The reconstruction project will be compatible with future plans to reconfigure the apron by relocating the terminal building and fueling areas, and expanding the apron to the south.

These projects represent the first step in the long-term development of aviation facilities at the airport. The projects identified for the first stage have been limited to the most critical needs due to the practical funding constraints faced by the airport sponsor and the limited availability of federal AIP dollars. In the event that additional funds become available, the projects listed early in Long Term period may be accelerated. The estimated cost of Short Term improvements is \$2,464,000. Each of the five projects included in the short term group are eligible for FAA funding participation.

LONG TERM DEVELOPMENT

Long term projects represent the balance of prioritized needs during the current twenty year planning period. As demands continue to evolve at the airport it is likely that some projects will need to be shifted up or down in the order. The initial projects identified as long term projects are currently needed; however, due to practical funding limitations, these projects will be deferred until the more critical projects are completed and additional funding can be obtained.

Long term projects include a 3,500-foot realignment of the West Bench Road along the southeast corner of the airport; a reconfiguration and expansion of terminal area auto parking; the first phase of airport security fencing (12,000 linear feet) adjacent to Runway 17-35; expansion of the main apron to provide additional aircraft parking; and construction of the North GA apron and lease area for larger conventional hangars. Installation of precision approach path indicators (PAPI) on Runways 17 and 9, and runway end identifier lights (REIL) on Runways 9 and 17 is also

recommended for the long term. Additional hangar taxilanes and a new tiedown apron would be added to the North GA area; the second phase of security fencing (8,500 lf) would provide continuous fencing coverage for all active airfield areas. The relocation of the terminal building and replacement of the existing underground fuel storage tanks are recommended as part of the overall reconfiguration of the main apron. These projects are dependent upon the realignment of the West Bench Roadway.

Providing taxiway access to Runway 9-27 is divided into two phases, with the initial phase consisting of a 1,900-foot access taxiway from the main apron to the approximate mid-point of the runway. The second phase would continue with a 1,500 to 2,200-foot parallel taxiway section to the end of Runway 27.

Approximately 15 acres of property acquisition is recommended along the northwest corner of the airport. It appears that a large portion of the developable land area available on the east side of Runway 17-35 will be used within the next twenty years. Property acquisition on the opposite side of the runway will protect the option of adding future aircraft parking and hangar areas. Access to the west side facilities would be provided by a roadway extending around the north end of Runway 17-35. Local interest in developing a large industrial site immediately west of the airport would be compatible with this development and the access which would be required.

Several projects are identified which are related to upgrading Runway 17-35 to meet ADG II standards. Another long term need is the addition of medium-intensity taxiway edge lighting (MITL) on the Runway 17-35 parallel taxiway system. Reflective edge markers are adequate for current and projected activity well into the planning period.

The extension of Runway 9-27 is identified as one of the last long term projects. As a secondary runway, Runway 9-27 should have a length of approximately 4,000 feet. The future of the runway will be in large part determined by the future improvements on Runway 17-35.

The estimated cost of Long Term improvements is \$4,144,250.

Table 6-1
John Day State Airport
20-Year Capital Improvement Program

Short Term Projects	Total Cost	FAA	State	Local
1. Reconstruct Rwy 16-34, RSA, MIRL (5000x60)	\$1,312,500	\$1,181,250	\$65,625	\$65,625
2. North Hangar Area Taxilanes (2 at 20x300)	\$39,000	\$35,100	\$1,950	\$1,950
3. Crackfill/Sealcoat, Drainage Rwy 9-27 (3436x60)	\$137,500	\$123,750	\$6,875	\$6,875
4. Rwy 16-34 P. Taxiway Reconstruct/Extend (5000x35)	\$700,000	\$630,000	\$35,000	\$35,000
5. Main Apron Reconstruction (7000sy)	\$275,000	\$247,500	\$13,750	\$13,750
Total - Short Term	\$2,464,000	\$2,217,600	\$123,200	\$123,200

Note: All figures include a 25 percent overhead multiplier for engineering, administration, and contingencies.

Table 6-1
John Day State Airport
20-Year Capital Improvement Program

Future (Long Term) Projects	Total Cost	FAA	State	Local
1. Realign Airport Access Road/West Bench (3500lf)	\$437,500	\$393,750	\$21,875	\$21,875
2. Reconfigure/Expand Terminal Auto Parking (7000s)	\$22,750	\$0	\$11,375	\$11,375
3. Airport Security Fencing (Phase I - 12000lf)	\$225,000	\$202,500	\$11,250	\$11,250
4. Main Apron Expansion (5900sy)	\$212,500	\$191,250	\$10,625	\$10,625
5. North GA Apron (250x250)	\$250,000	\$225,000	\$12,500	\$12,500
6. PAPI Rwys 16 & 9	\$37,500	\$33,750	\$1,875	\$1,875
7. REIL Rwy 9	\$12,500	\$11,250	\$625	\$625
8. Security Fencing (Phase II - 8500lf)	\$160,000	\$144,000	\$8,000	\$8,000
9. North Hangar Taxilanes (2 at 20x300)	\$39,000	\$35,100	\$1,950	\$1,950
10. Aircraft Parking Expansion (4000sy)	\$144,000	\$129,600	\$7,200	\$7,200
11. Rwy 9-27 Access Taxiway Phase I (1900x35)	\$266,250	\$239,625	\$13,313	\$13,313
12. Replace Underground Fuel Tanks	\$81,250	\$0	\$0	\$81,250
13. Relocate FBO Building	\$25,000	\$0	\$12,500	\$12,500
14. Property Acquisition (NW) (15 acres)	\$93,750	\$84,375	\$4,688	\$4,688
15. Widen (75 feet) & Resurface Rwy 16-34 (5000x75)	\$768,750	\$691,875	\$38,438	\$38,438
16. Sealcoat Main Apron (11000sy)	\$25,000	\$22,500	\$1,250	\$1,250
17. North GA Tiedown Apron (6,000 sy)	\$216,000	\$194,400	\$10,800	\$10,800
18. Rwy 9-27 Parallel Taxiway (35x2200)	\$308,750	\$277,875	\$15,438	\$15,438
19. Rwy 16-34 ADG II RSA Upgrade (150x300)	\$250,000	\$225,000	\$12,500	\$12,500
20. Rwy 16-34 P.Txy Edge Lights (MITL) (5000lf)	\$106,250	\$95,625	\$5,313	\$5,313
21. Crackfill/Slurry Seal Rwy 9-27 (3436x60)	\$50,000	\$45,000	\$2,500	\$2,500
22. Crackfill & Seal Rwy 16-34 & P.Txy (5000x60 & x3)	\$100,000	\$90,000	\$5,000	\$5,000
23. Rwy 9-27 & P.Txy Extension (500x60 & 500x35)	\$312,500	\$281,250	\$15,625	\$15,625
Total Long Term	\$4,144,250	\$3,613,725	\$224,638	\$305,888
TOTAL - ALL STAGES	\$6,608,250	\$5,831,325	\$347,838	\$429,088

Note: All figures include a 25 percent overhead multiplier for engineering, administration, and contingencies.

AIRPORT CAPITAL IMPROVEMENTS FINANCING

While the primary responsibility for financing capital facility development rests with the sponsor, there are a number of sources from which airport development funds can be derived. Money for capital improvements may come from a number of sources and may be used singly or in combination to accomplish airport development. Sources for financing airport facilities include the FAA's Airport Improvement Program (AIP), state economic development funds, private donations, lease-backs, direct revenue loans, and certificates of participation. Local participation, donations of equipment, labor, and materials can also contribute to the implementation of the capital program.

As a state owned airport, the capital improvement program for John Day is managed by the Oregon Department of Transportation Aeronautics. Improvements at John Day State, along with the needs of more than 30 other state owned community airports are balanced as funds are available. Demand for facility improvements far exceeds annual funding; the result is that many facility needs are deferred over extended periods until funding can be obtained. The state also looks to local communities for support in funding capital improvements.

FAA funds for airport development, which are derived from user fees, are available for land acquisition, construction, alteration, fire fighting, and crash rescue vehicles and facilities, as well as for establishing and improving air navigation facilities. Publicly-owned airports are eligible for such aid provided the proposed project is included in the National Plan. The federal share of these projects in Oregon is 90 percent of eligible costs as outlined above.

THIRD-PARTY SUPPORT

ODOT Aeronautics and Grant County have a strong interest in continued private support and development of John Day State Airport. As business and industry benefit from the use of the airport, they should be encouraged to invest in additional improvements, including hangars, and corporate facilities on leased land parcels. This type of support lowers the sponsor's overall cost of providing facilities needed for the airport, while providing opportunities for private investment. In addition to improving the financial outlook for development and operation, it also stimulates civic participation and pride in the airport.

Airport Layout Plan Report

for

**John Day State Airport
John Day, Oregon**

prepared for the

**Oregon Department of Transportation
Aeronautics**

and

Grant County Airport Commission

Chapter Seven

AIRPORT ENVIRONMENTAL CHECKLIST

The purpose of the *Environmental Checklist* is to identify physical and environmental conditions of record which may affect improvement options at John Day State Airport. In comparison to an Environmental Assessment or Environmental Review, the project scope was quite limited in this case, and included soliciting information of record from the applicable local, state and federal sources relative to the elements of environmental assessment as they apply to this site. The scope of the Environmental Checklist research did not involve extensive interpretation of the information, in-depth analyses, or the more comprehensive, follow-up correspondence and inquiries with affected agencies and persons as is normally associated with Environmental Assessments (EA's) and Reviews (ER's).

All research activities, including correspondence, data collection and documentation, proceeded under the provisions of FAA Order 5050.4A, The Airport Environmental Handbook, which is intended to implement the requirements of Sections 1505.1 and 1507.3 of the National Environmental Policy Act (NEPA). This report briefly addresses each potential impact category identified by Order 5050.4A as to be investigated under the EIS or EA processes; if a particular potential environmental impact category did not apply to this study site, the checklist is noted accordingly. Below is a brief summary of the impact categories in which potentially significant impacts were identified or are possible and where notable ecological or social conditions appear pertinent to the future development of this facility.

Noise Compatibility and Land Use

The airport is located approximately ½ mile southwest of the City limits of John Day, Oregon, and

about 3/4 of a mile northwest of the City of Canyon City, Oregon. It is within the John Day Urban Growth Boundary, and also abuts Canyon City's city limits on the airfield's south side. Noise impacts of the Preferred Alternative are not expected to be significant, due largely to the location of the airstrip at a considerably higher elevation than surrounding development and noise-sensitive uses. No airport overlay zoning was identified for this facility, and zoning maps provided to the consultant by the City do not indicate that zoning overlay measures have been implemented to protect the John Day airport from incompatible uses. Overlay zoning does not affect existing surface zoning, but is designed to protect the airspace surrounding an airport, by providing height and hazard guidance for lands located beneath FAR Part 77 imaginary airspace surfaces. Being located approximately 700 feet above the elevation of the City of John Day, the airport's distance from urban activities, coupled with the topographical relief surrounding the facility, helps preclude many incompatible uses.

The airport is surrounded by relatively open land at this time. The airport is zoned AA (Airport); lands located immediately northwest to the airport are zoned AA - Industrial. The majority of the remaining lands immediately adjacent to the airport are zoned low density residential or recreational.

The development of an airport overlay zone is recommended for John Day State Airport. Potential incompatible land uses within this zone should be carefully considered by local land use planning authorities.

1994 and 2014 Contours

Figure 7-1 depicts the current and twenty-year noise contours for John Day State Airport. The contours were generated using the FAA's Integrated Noise Model (Version 4.11) and reflect current and forecast air traffic levels. The twenty-year contours are also depicted on the Airport Land Use Plan (Drawing 3). The Land Use Plan utilizes a photographic base, which provides a ground reference for the contours.

Due to the level of forecast operations, the noise contours for both current conditions and twenty years are relatively small, with the 65 Ldn contours contained almost entirely within airport property boundaries. A small portion of the 20-year 65 Ldn contour extends outside the southwest corner of the airport; the current 65 Ldn contour is contained entirely within airport boundaries.

A small portion of the 20-year 60 Ldn contour extends beyond airport property along the southern edge of the airport (parallel to Runway 9-27); the southwest corner of the airport; and near the northeast corner of the airport.

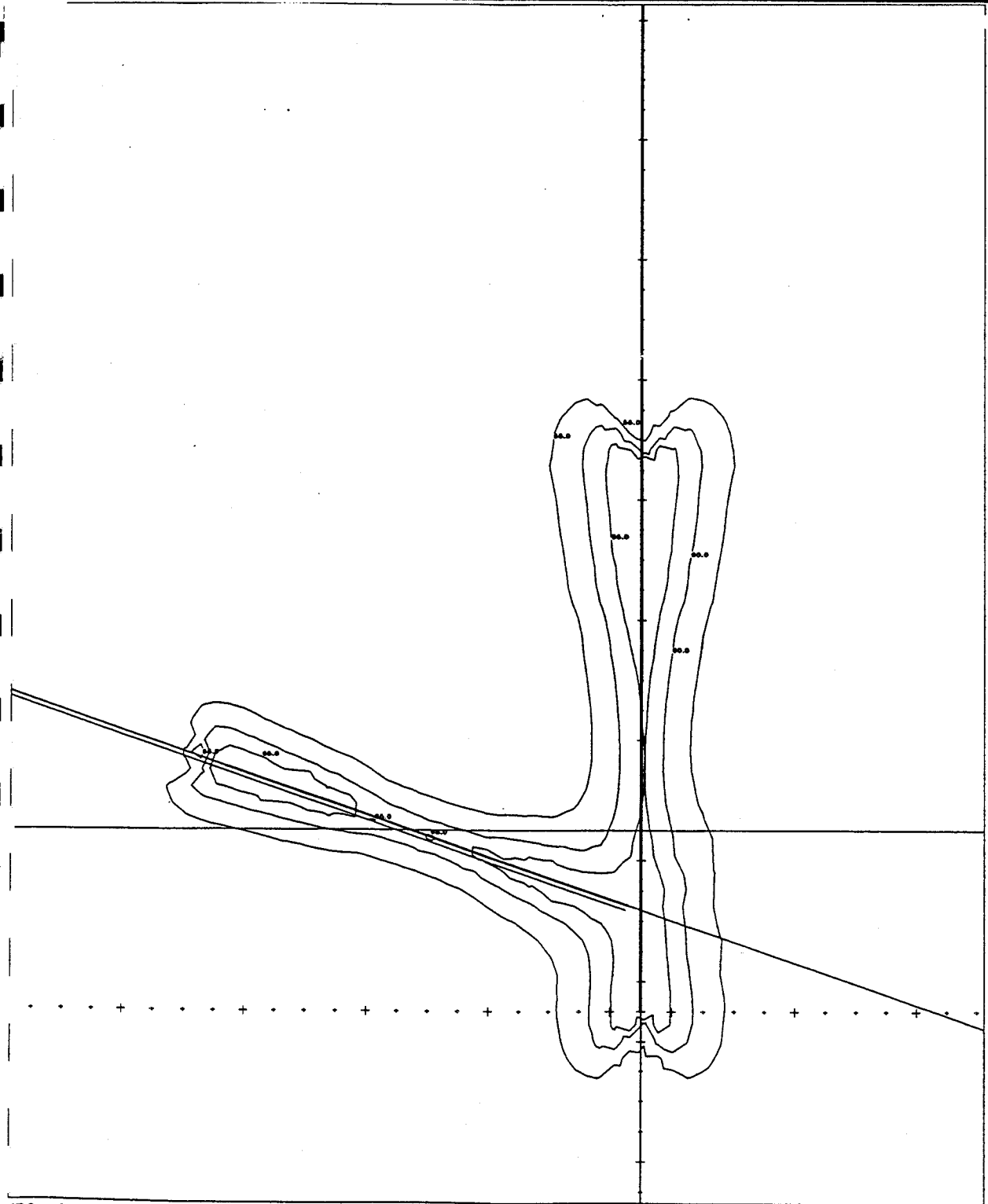

JD94A.INP / 1994 BASE DATA
 JOHN DAY STATE AIRPORT
 METRIC = LDN
 AREA(SQ MI) = 55.00 60.00 65.00
 0.32 0.17 0.07

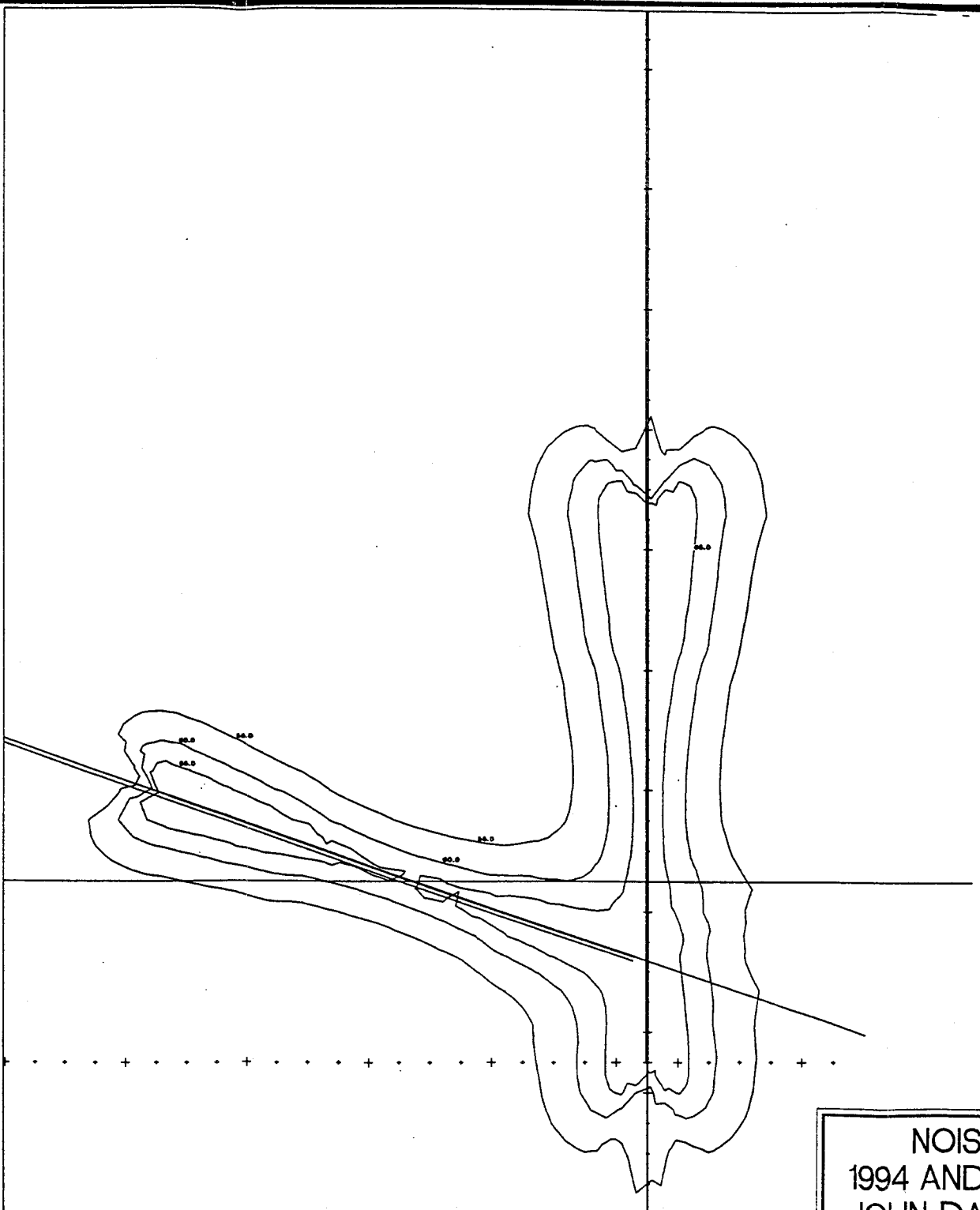

JD14A.INP / 2014 BASE DATA
 JOHN DAY STATE AIRPORT
 METRIC = LDN
 AREA(SQ MI) = 55.00 60.00 65.00
 0.48 0.27 0.13

FIGURE 7-1

NOISE CONTOURS
 1994 AND 2014 BASE DATA
 JOHN DAY STATE AIRPORT

 **DEVCO**
 engineering inc. Corvallis
 Oregon
 (503) 757-8991

David Miller & Associates
 Aviation Consultants
 Eugene, Oregon

NOI/BLNK

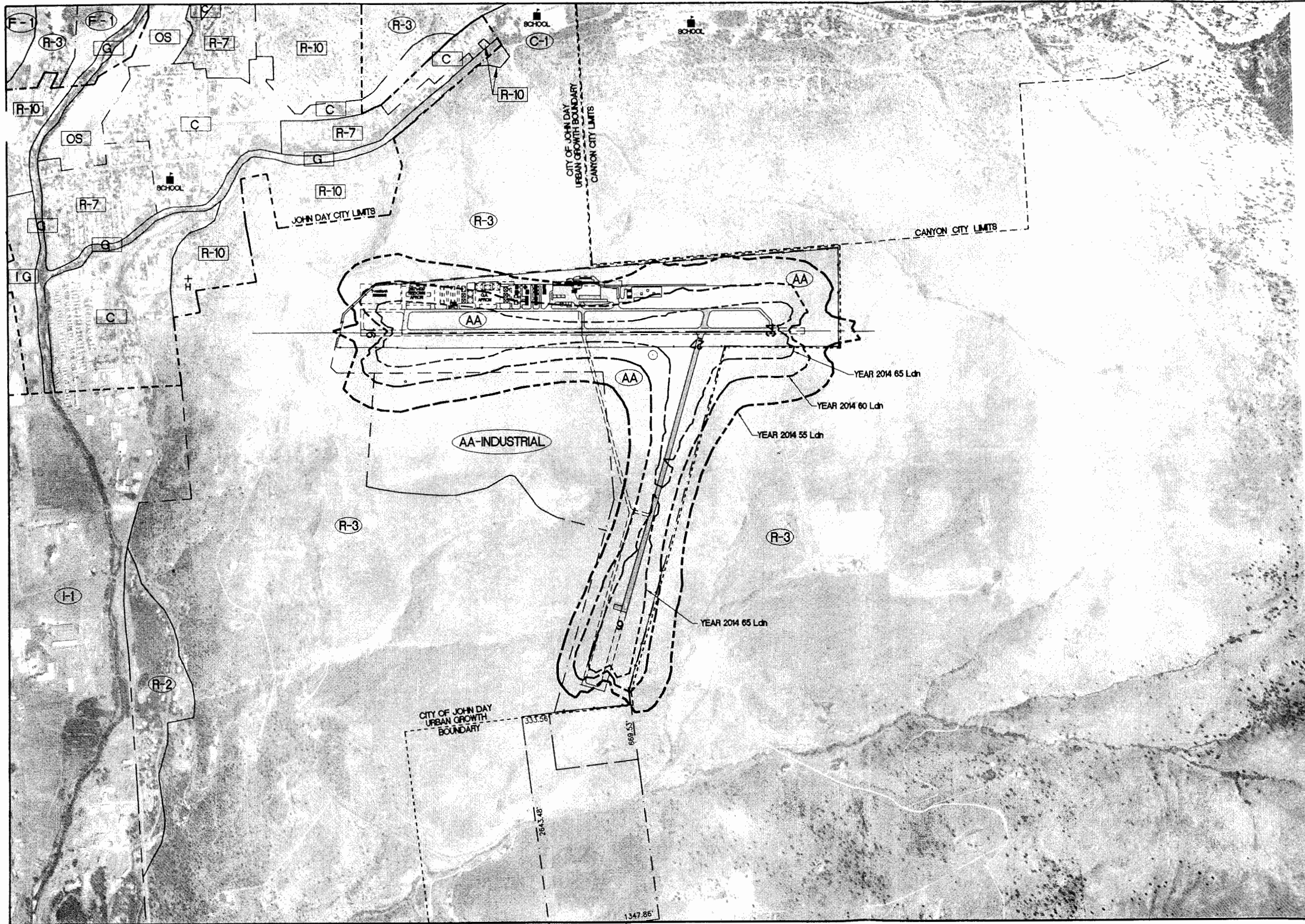

LEGEND

- YEAR 2014 55 Ldn CONTOUR
- YEAR 2014 60 Ldn CONTOUR
- YEAR 2014 65 Ldn CONTOUR
- AIRPORT PROPERTY LINE
- CITY LIMITS
- URBAN GROWTH BOUNDARY
- SCHOOL
- ⊕ HOSPITAL

GRANT COUNTY ZONING

- (A-A) AIRPORT
- (AA(IND)) AIRPORT INDUSTRIAL
- (C-1) COMMERCIAL
- (F-1) EXCLUSIVE FARM
- (I-1) INDUSTRIAL
- (R-2) RESIDENTIAL
- (R-3) RECREATIONAL

CITY OF JOHN DAY ZONING

- (OS) OPEN SPACE
- (G) GREENWAY
- (R-10) RESIDENTIAL
- (C) COMMERCIAL
- (IG) INDUSTRIAL - GENERAL

CANYON CITY IS ZONED RESIDENTIAL

T13S, R31E
SECTIONS
27, 28, 34, 35
GRANT COUNTY,
OREGON

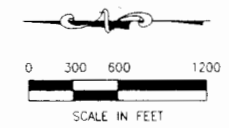

NOTE:
THE CITY OF JOHN DAY AND GRANT COUNTY ARE ENCOURAGED TO DEVELOP AND ESTABLISH AN AIRPORT VICINITY OVERLAY ZONE WHICH SHOULD BE DESIGNED TO GUIDE DEVELOPMENT AND LAND USES ON AND AROUND THE LAND SURROUNDING THE AIRPORT. THE ORDINANCE SHOULD INCLUDE HEIGHT RESTRICTIONS WHICH ARE INTENDED TO PROTECT FAR PART 77 AIRSPACE IMAGINARY SURFACES.

<p style="text-align: center;">APPROVAL BLOCK</p> <p style="text-align: center;">FEDERAL AVIATION ADMINISTRATION</p> <p style="text-align: center;">SIGNATURE _____</p> <p style="text-align: center;">TITLE _____</p> <p style="text-align: center;">DATE _____</p>	<p style="text-align: center;">APPROVAL BLOCK</p> <p style="text-align: center;">OREGON DEPT. OF TRANSPORTATION AERONAUTICS</p> <p style="text-align: center;">SIGNATURE _____</p> <p style="text-align: center;">TITLE _____</p> <p style="text-align: center;">DATE _____</p>
---	--

The preparation of this document was financed in part by a planning grant from the FAA as provided under Section 505 of the Airport and Airways Improvement Act of 1982. This document does not necessarily reflect the views of the FAA.

**OREGON DEPARTMENT
OF TRANSPORTATION
AERONAUTICS**



**JOHN DAY STATE AIRPORT
LAND USE PLAN AND
NOISE CONTOURS**

No. REVISION	DATE

Job No. 94-016 ISSUED: 10/14/96

DRAWING	OF
3	3

Portions of the 20-year 55 Ldn contour extend beyond airport property along the northwest, northeast, and southwest corners of the airport; and beyond the airport property lines along both sides of Runway 9-27.

As noted in **Table 7-1**, all land uses are compatible with noise levels at or below 65 Ldn. Based on FAA noise compatibility planning standards and existing zoning, no conflicts exist between airport noise and existing land use. There are no residences or structures identified within the 55 Ldn contour or higher. As a result, the airport does not create a significant noise impact on the surrounding community. A description of the methodologies used in generating the noise contours is provided below.

LDN METHODOLOGY

A methodology has been devised to relate measurable sound from a variety of sources to community response. Termed "Day-Night Average Sound Level" (Ldn), this metric has been adopted by the U.S. Environmental Protection Agency, Department of Housing and Urban Development, Oregon Department of Environmental Quality (DEQ), and the Federal Aviation Administration to use in evaluating noise impacts.

The basic unit in the computation of Ldn is the sound exposure level (SEL). An SEL is computed by adding the dBA level for each second of a noise event above a certain threshold. For example, a noise monitor located in a residential area with a background noise level of 45 dBA receives the sound impulses of an approaching aircraft and records the dBA reading for each second of the event as the aircraft approaches and departs the site. Each of these one-second readings is then added logarithmically to compute the SEL. Because of the logarithmic calculation, noise levels below 10 dBA of the maximum level are significant in terms of Ldn value.

The computation of an airport Ldn involves the addition, weighting, and averaging of each SEL to achieve an Ldn level at particular location. The SEL of each noise event occurring between the hours of 10:00 p.m. and 7:00 a.m. is automatically weighted by adding 10 dBA to the SEL to account for the assumed additional irritation perceived during that period. All SELs are then averaged over a given time period (day, week, year) to achieve a level characteristic of the total noise environment.

Stated simply, an Ldn is approximately equal to the average dBA level during an entire time period, with a weighting for nighttime noise events. Thus, a 65 Ldn level describes an area as having a time-averaged constant noise level of 65 dBA during the daytime and 55 dBA during the nighttime, even though the area would experience noise events higher and lower than 65 dBA. The main

advantage of Ldn is that it provides a common measure for a variety of different noise environments. The same Ldn level can describe both an area with very few high-noise events and an area with many low level events.

The noise contours depicted begin at 55 Ldn, and in 5 Ldn increments, extend to 65 Ldn. Noise impacts upon adjacent land uses are discussed in the "Compatible Land Use" section of this chapter. As noted earlier, the existing and future noise levels projected for John Day State Airport will not create significant impacts on the surrounding community.

COMPATIBLE LAND USE

The compatibility of existing and planned uses in the vicinity of an airport is generally associated with the level of noise and safety impacts related to the airport. Compatibility or non-compatibility of land use is determined by comparing the Ldn noise contour with existing and potential land uses. The FAA has developed guidelines for land-use compatibility based on noise levels and the nature of the land use being impacted. Commercial, industrial, and most public uses are considered compatible with airport operations, as long as they are consistent with performance standards of Federal Aviation Regulation (FAR) **Part 77** relative to height and safety. Residential use is compatible in areas below the 65 Ldn noise contour. **Table 7-1**, provides the federal land-use compatibility guidelines.

In addition to federal guidelines, the State of Oregon DEQ has corresponding guidelines for noise compatibility and requires that an "Airport Noise Impact Boundary" be included in Airport Master Plans, with contours depicted down to 55 Ldn. While 55 Ldn establishes the parameters of the study area, federal guidelines provide that noise-sensitive land uses located in areas with impacts below 65 Ldn are considered compatible with aviation activity. Like the FAA, DEQ recommends mitigation measures for noise-sensitive land uses lying in areas with impacts exceeding 65 Ldn.

**Table 7-1
LAND-USE COMPATIBILITY
WITH YEARLY DAY-NIGHT AVERAGE SOUND LEVELS**

Land Use	Yearly Day-Night Average Sound Level (Ldn) In Decibels						Over
	65	Below 65-70	70-75	75-80	80-85	85	
<u>Residential</u>							
Residential, other than mobile homes & transient lodgings		Y	N(1)	N(1)	N	N	N
Mobile Home Parks		Y	N	N	N	N	N
Transient Lodgings		Y	N(1)	N(1)	N(1)	N	N
<u>Public Use</u>							
Schools		Y	N(1)	N(1)	N	N	N
Hospitals and Nursing Homes		Y	25	30	N	N	N
Churches, Auditoriums, and Concert Halls		Y	25	30	N	N	N
Governmental Services		Y	Y	25	30	N	N
Transportation		Y	Y	Y(2)	Y(3)	Y(4)	Y(4)
Parking		Y	Y	Y(2)	Y(3)	Y(4)	N
<u>Commercial Use</u>							
Offices, Business and Professional		Y	Y	25	30	N	N
Wholesale and Retail--Building Materials, Hardware and Farm Equipment		Y	Y	Y(2)	Y(3)	Y(4)	N
Retail Trade--General		Y	Y	25	30	N	N
Utilities	Y	Y	Y(2)	Y(3)	Y(4)	N	
Communication		Y	Y	25	30	N	N
<u>Manufacturing and Production</u>							
Manufacturing General		Y	Y	Y(2)	Y(3)	Y(4)	N
Photographic and Optical	Y	Y	25	30	N	N	
Agriculture (except livestock) and Forestry		Y	Y(6)	Y(7)	Y(8)	Y(8)	Y(8)
Livestock Farming and Breeding		Y	Y(6)	Y(7)	N	N	N
Mining and Fishing, Resource Production and Extraction		Y	Y	Y	Y	Y	Y
<u>Recreational</u>							
Outdoor Sports Arenas, Spectator Sports		Y	Y(5)	Y(5)	N	N	N
Outdoor Music Shells, Amphitheaters		Y	N	N	N	N	N
Nature Exhibits and Zoos		Y	Y	N	N	N	N
Amusements, Parks, Resorts and Camps		Y	Y	Y	N	N	N
Golf Courses, Riding Stables and Water Recreation		Y	Y	25	30	N	N

Table 7-1 (Continued)

Y (Yes)	Land-use and related structures compatible without restrictions.
N (No)	Land-use and related structures are not compatible and should be prohibited.
NLR	Noise Level Reduction (outdoor to indoor) to be achieved through incorporation of noise attenuation into design and construction of the structure.
25, 30 or 35	Land uses and structures generally compatible; measures to achieve NLR of 25, 30, or 35 dB must be incorporated into design and construction of the structure.

NOTES:

1. Where the community determines that residential uses must be allowed, measures to achieve outdoor to indoor Noise Levels Reduction (NLR) of at least 25dB and 30dB should be incorporated into building codes and be considered in individual approvals. Normal residential construction can be expected to provide a NLR of 20 dB; thus, the reduction requirements are often stated as 5, 10, or 15 dB over standard construction and normally assume mechanical ventilation and closed windows year-round. However, the use of NLR criteria will not eliminate outdoor noise problems.
2. Measures to achieve NLR of 25 dB must be incorporated into the design and construction of portions of these buildings where the public is received, office areas, noise sensitive areas, or where the normal noise level is low.
3. Measures to achieve NLR of 30 dB must be incorporated into the design and construction of portions of these buildings where the public is received, office areas, noise sensitive areas, or where the normal noise level is low.
4. Measures to achieve NLR of 35 dB must be incorporated into the design and construction of portions of these buildings where the public is received office areas, noise sensitive areas, or where the normal noise level is low.
5. Land-use compatible, provided special sound reinforcement systems are installed.
6. Residential buildings require an NLR of 25.
7. Residential buildings require an NLR of 30.
8. Residential buildings not permitted.

SOURCE: Federal Aviation Regulations, Part 150, Airport Noise Compatibility Planning, dated January 18, 1985.

Other Considerations

Social and induced socioeconomic impacts of the Preferred Alternative would be expected to be positive. Within the planning period, both runways are targeted for extension. Realignment of the access road to increase its distance from US Forest Service copter pads on-site will have positive safety impacts, as will the installation of low or medium-intensity runway lighting, widening Runway 17-35, and incrementally providing deer fences for the airport's perimeter, as budgeting allows.

Air quality would not be expected to be adversely impacted. Water quality impacts are always a concern with any construction project, and especially when considering uses and sites where potentially hazardous materials, such as aviation fuel or fire retardants in this case, are involved. Water is currently piped to the airport from the City, and septic tanks handle on-site sewage needs. The Oregon Department of Environmental Quality routinely recommends for airport projects that, at a minimum, investigations be performed which divulge past agricultural spraying practices, aviation fuel storage facilities, and other potential sources for adverse water quality impacts associated with past, present and potential future activities at the site. Adherence to local, state, and federal regulations and standards, and compliance with the guidelines of FAA Advisory Circular 150/5370-10 would help protect against adverse water quality or quantity impacts.

The Preferred Alternative could feasibly be accommodated on existing airport lands, and no additional public land or parks would be affected by development at this site. The Oregon State Historic Preservation Office, SHPO, has indicated that no known cultural sites are recorded in the immediate area proposed for development, and that no surveys have been performed to confirm or deny the presence of significant sites under this impact category. The correspondence notes the presence of a number of historic mining sites in the John Day and Canyon City vicinity, attributable to "the mining boom". None of these would be expected to be impacted by the proposed development. If any historic or cultural resources are discovered during construction, the sponsor will be responsible for notifying SHPO and other appropriate authorities and for protecting the resource(s) from adverse impacts or damages resultant from activities associated with the planned improvements to John Day Airport.

A representative of the Oregon Department of Fish and Wildlife indicated that this area is crucial wintering range for mule deer and antelope, and reported that a collision occurred between a Cessna 182 attempting take-off from this site and an antelope in 1993. Other problems associated with deer and antelope on airport property include mud, rocks and dust tracked onto the runways by the animals. Coyote, cougar, and falcon are also reported to occur in the project vicinity. The ODFW representative did not express concerns about the Preferred Alternative relative to these species.

The U.S. Department of Fish and Wildlife lists one species of fauna, the Bald eagle, or *Haliaeetus*

leucocephalus, as occurring (a roosting site is reported to exist) in the same Township as the airport property. The Bald eagle is Listed as a Threatened species under the Endangered Species Act. Several Candidate species, for which significant biological information needed to list as Threatened or Endangered is lacking, but which may become listed prior to the project's completion, were also listed in the correspondence from USFWS. Candidate species are not afforded any Federal protection. Candidate species around this site include several species of bat; the Pygmy rabbit; Western burrowing owl; and the Ferruginous hawk. In addition, one species of flora, Arrow-leaf thelypody, is indicated as occurring near the project site. This is also a Candidate species which may be provided Federal protection in the future.

Predominantly Class IV and VI soils compose and surround this site (IV irrigated, VI non-irrigated). In Western Oregon, all Class I-VI soils are considered prime agricultural soils, and would be considered to be of statewide significance under FAA Order 5050.4A. Since existing airport property could facilitate the Preferred Alternative, no conversion of prime, unique or significant soils would occur as a result of the planned improvements to John Day Airport.

Increased energy and natural resource needs of any improvement project would be expected to be slight. The facility's distance from the John Day and Canyon City city limits, combined with the difference in elevation between the airport and light sensitive uses, helps to preclude adverse impacts of the planned improvements relative to glare or light emissions which might be hazardous to aircraft operations.

Significant solid waste impacts are not expected. Silt fences and runoff diversion tactics are commonly implemented in similar projects and should be utilized for any project on this airfield. In conjunction with those efforts, the selection of areas on-site where ground disturbance associated with development will have the minimum foreseeable impact on groundwater and other elements of the environment is recommended to further reduce construction impacts. FAA Advisory Circular 150/5370-10 provides additional measures which should be implemented to minimize adverse impacts of airport construction activities.

**TABLE 7-2
ENVIRONMENTAL CHECKLIST**

Potential Impact Category	<u>Existing Conditions/Comments</u>	Agency Advocate Further Analysis, <u>Some Impact Likely?</u>
Noise	No residences within current and 20-year 55, 60, and 65 Ldn contour. Surrounding land uses compatible with 65 Ldn and lower noise contours.	NO
Compatible Land Use	Terrain and distance from urban activities, uses, make adverse impact in this category unlikely. Airfield located ½ mile from John Day City limits. No further analysis was performed.	NO
Social/Socio- Economic Impacts	Expected to be positive, as is typical with airport projects.	YES
Air Quality	No significant change in current conditions is anticipated.	NO
Water Quality	Water and septic needs will need to be provided in an environmentally efficient manner. DEQ typically concerned with past and present practices relative to agricultural spray runoff, fuel storage; recommend investigation of same to determine likelihood of existing contamination issues.	POSSIBLE

**TABLE 7-2
ENVIRONMENTAL CHECKLIST**

<u>Potential Impact Category</u>	<u>Existing Conditions/Comments</u>	<u>Agency Advocate Further Analysis, Some Impact Likely?</u>
Special Land Uses, DOT Act, Section 4(f)	No parks or public land outside airport property affected.	NO
Historic, Architectural, Archaeological, and Cultural Resources	SHPO indicates no known cultural sites or resources would be affected. No surveys conducted/recommended.	POSSIBLE
Biotic Communities	A number of species of fauna were discussed in the narrative above as possibly occurring in the project vicinity. Biotic Survey is generally recommended by USFWS and Oregon DFW. Mule deer and antelope creating problems on runways and airport property, as discussed. Fencing will improve this condition.	YES
Endangered and Threatened Species, Flora and Fauna	Eight listed and candidate species of fauna on record in vicinity. One Candidate species of flora indicated by the USFWS correspondence, attached. See narrative, above.	YES

PCI REPORT

Site Name : ODOT-Aeronautics Section - John Day State Airport
 Database Name : C:JOHNDAY Report Date: JUN/30/1995

Netwrk ID	Branch Number	Section	Num/Rank/Surf/Length(LF)/Area(SF)	Last Construct Date	Last Inspection Date	PCI
00028	T02JD	03 / S / AC /	245.00/ 7452.00	AUG/01/1962	JUN/26/1994	65
	TAXIWAY 02	JOHN DAY	Cat:P Zone:5JO	Family:DEFAULT	Age (Yrs):31.9	
	TAXIWAY	From: T01JD	To: Hangars			
00028	R16JD	01 / P / AC /	4500.00/ 225000.00	AUG/01/1962	JUN/26/1994	54
	RUNWAY 16/34	JOHN DAY	Cat:P Zone:5JO	Family:DEFAULT	Age (Yrs):31.9	
	RUNWAY	From: R16 End	To: R34 End			
00028	T06JD	01 / P / AC /	124.00/ 3860.00	AUG/01/1962	JUN/26/1994	53
	TAXIWAY 06	JOHN DAY	Cat:P Zone:5JO	Family:DEFAULT	Age (Yrs):31.9	
	TAXIWAY	From: T01JD	To: A01JD			
00028	A01JD	01 / P / AC /	240.00/ 43222.00	AUG/01/1962	JUN/26/1994	46
	APRON 01	JOHN DAY	Cat:P Zone:5JO	Family:DEFAULT	Age (Yrs):31.9	
	APRON	From: See Map	To:			
00028	A02JD	01 / S / AC /	313.00/ 9390.00	AUG/01/1962	JUN/26/1994	46
	APRON 02	JOHN DAY	Cat:P Zone:5JO	Family:DEFAULT	Age (Yrs):31.9	
	APRON	From: See Map	To:			
00028	T01JD	01 / P / AC /	4776.00/ 143471.00	AUG/01/1962	JUN/26/1994	46
	TAXIWAY 01	JOHN DAY	Cat:P Zone:5JO	Family:DEFAULT	Age (Yrs):31.9	
	TAXIWAY	From: R16 End	To: R34 End			
00028	T03JD	01 / P / AC /	210.00/ 7072.00	AUG/01/1962	JUN/26/1994	44
	TAXIWAY 03	JOHN DAY	Cat:P Zone:5JO	Family:DEFAULT	Age (Yrs):31.9	
	TAXIWAY	From: R16JD	To: T01JD			

Figure JD-1. Section and Sample Unit Layout
John Day State Airport

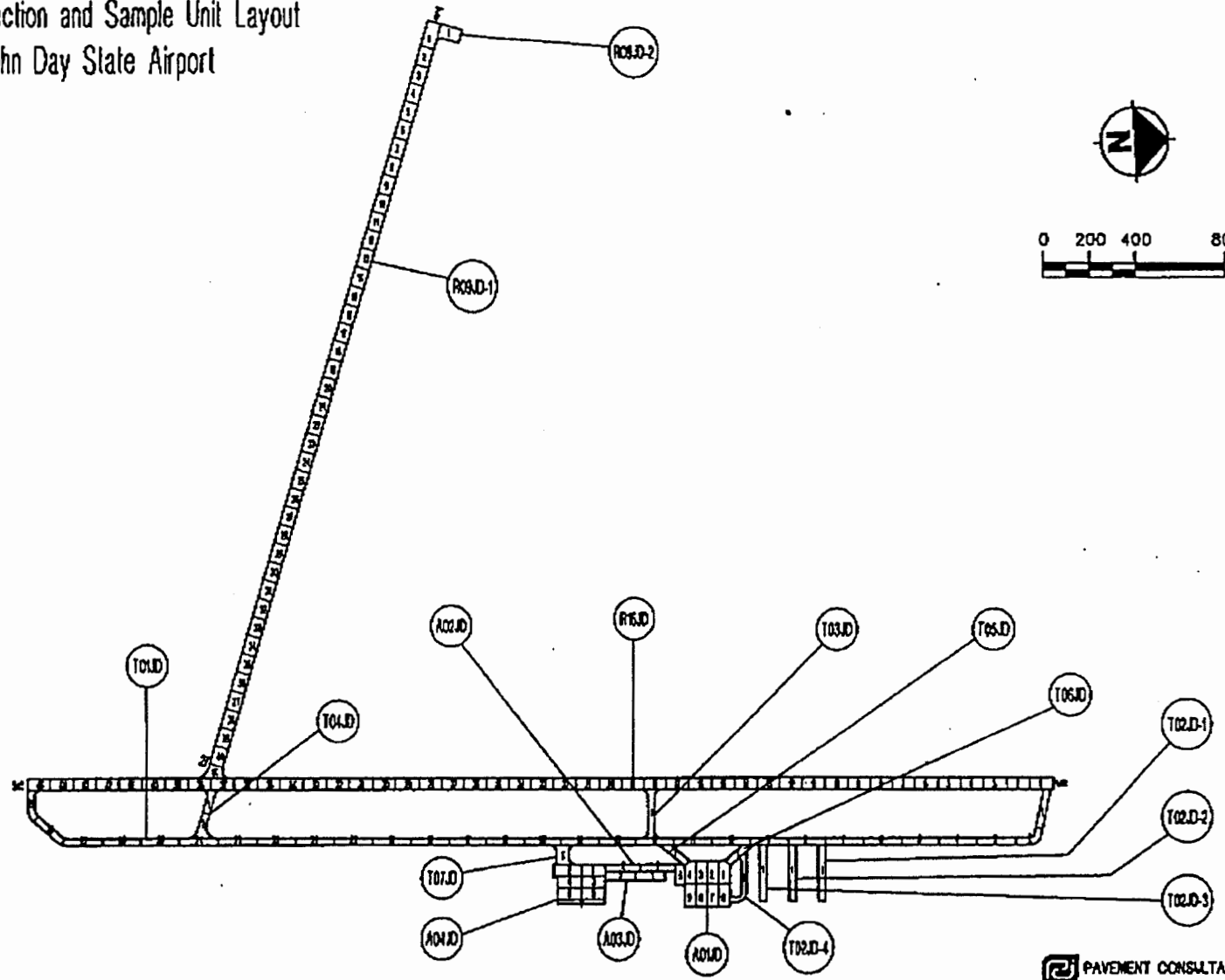

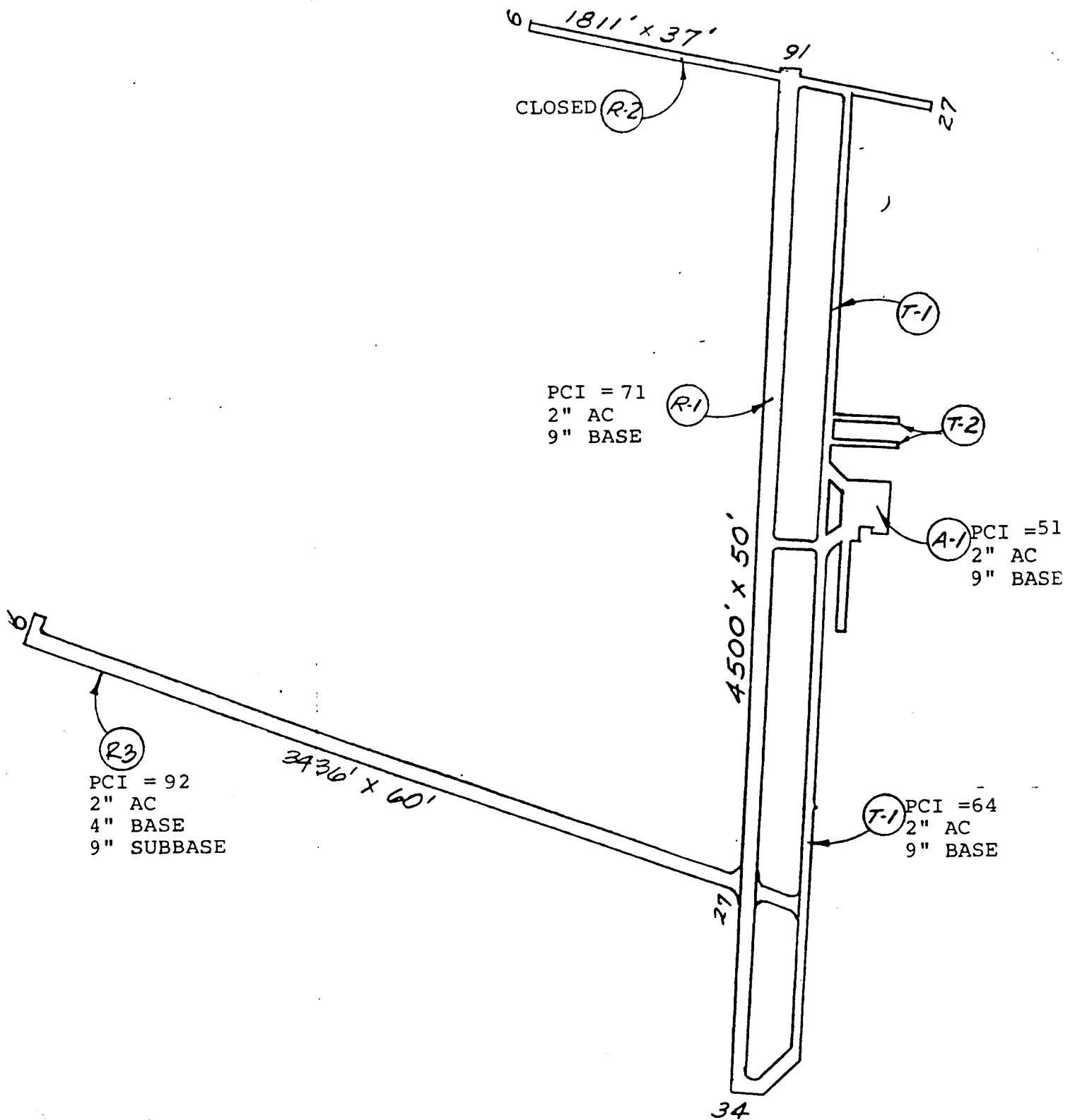

JOHN DAY STATE AIRPORT

PAVEMENT FEATURES AND PCI NUMBERS

APRIL 4, 1989

FEATURE SUMMARY

REPORT: JOHN DAY STATE AIRPORT
DATE OF SURVEY: APRIL 4, 1989

AIRPORT FACILITY: Runway 16-34 R-1
TOTAL NO. OF SAMPLE UNITS: 6

<u>SAMPLE UNIT NO.</u>	<u>SAMPLE UNIT AREA</u>	<u>PCI</u>
1	5000	67
2	5000	73
3	5000	74
4	5000	72
5	5000	72
6	5000	67

Average PCI: 71
 Condition Rating: Very Good

AIRPORT FACILITY: Apron A-1
TOTAL NO. OF SAMPLE UNITS: 4

<u>SAMPLE UNIT NO.</u>	<u>SAMPLE UNIT AREA</u>	<u>PCI</u>
1	5000	42
2	5000	60
3	5000	24
4	5000	78

Average PCI: 51
 Condition Rating: Good

AIROPRT FACILITY: Runway 9-27 R-3
TOTAL NO. OF SAMPLE UNITS: 6

<u>SAMPLE UNIT NO.</u>	<u>SAMPLE UNIT AREA</u>	<u>PCI</u>
1	5000	96
2	5000	89
3	5000	92
4	5000	86
5	5000	91
6	5000	96

Average PCI: 92
 Condition Rating: Excellent

AIRPORT FACILITY: Taxiway T-1
TOTAL NO. OF SAMPLE UNITS: 5

<u>SAMPLE UNIT NO.</u>	<u>SAMPLE UNIT AREA</u>	<u>PCI</u>
1	5000	57
2	5000	76
3	5000	71
4	5000	65
5	5000	50

Average PCI: 64
 Condition Rating: Good

**FLEXIBLE PAVEMENT
CONDITION SURVEY DATA SHEET FOR SAMPLE UNIT**

AIRPORT JOHN DAY STATE DATE 4-4-89

FACILITY RUNWAY 16-34 FEATURE R1 SAMPLE UNIT 1

SURVEYED BY RB/RB AREA OF SAMPLE 5000

- DISTRESS TYPES**
- | | |
|----------------------------|-------------------------|
| 1. ALLIGATOR CRACKING | 10. PATCHING |
| 2. BLEEDING | 11. POLISHED AGGREGATE |
| 3. BLOCK CRACKING | 12. RAVELING/WEATHERING |
| 4. CORRUGATION | 13. RUTTING |
| 5. DEPRESSION | 14. SHOIVING FROM PCC |
| 6. JET BLAST | 15. SLIPPAGE CRACKING |
| 7. JT. REFLECTION (PCC) | 16. SWELL |
| 8. LONG. & TRANS. CRACKING | |
| 9. OIL SPILLAGE | |

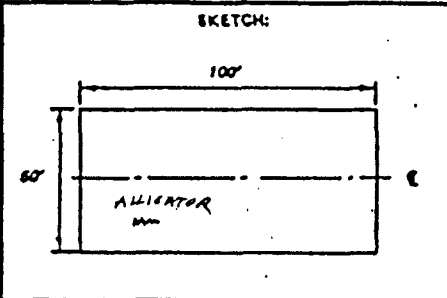

**FLEXIBLE PAVEMENT
CONDITION SURVEY DATA SHEET FOR SAMPLE UNIT**

AIRPORT _____ DATE _____

FACILITY _____ FEATURE _____ SAMPLE UNIT 2

SURVEYED BY _____ AREA OF SAMPLE _____

- DISTRESS TYPES**
- | | |
|----------------------------|-------------------------|
| 1. ALLIGATOR CRACKING | 10. PATCHING |
| 2. BLEEDING | 11. POLISHED AGGREGATE |
| 3. BLOCK CRACKING | 12. RAVELING/WEATHERING |
| 4. CORRUGATION | 13. RUTTING |
| 5. DEPRESSION | 14. SHOIVING FROM PCC |
| 6. JET BLAST | 15. SLIPPAGE CRACKING |
| 7. JT. REFLECTION (PCC) | 16. SWELL |
| 8. LONG. & TRANS. CRACKING | |
| 9. OIL SPILLAGE | |

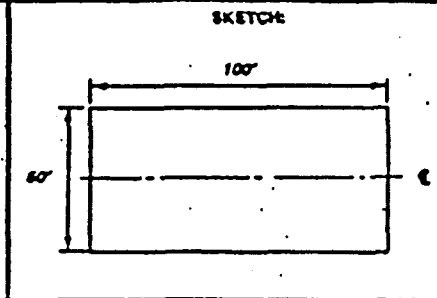

EXISTING DISTRESS TYPES

SEVERITY	TYPE	DENSITY %	DEDUCT VALUE
L	3	18%	15
M	8	53.5%	14
H	5	40%	5
L	12	3%	6
TOTAL SEVERITY			
L	53.5'	40%	
M	8'	3%	
H	18'		

EXISTING DISTRESS TYPES

SEVERITY	TYPE	DENSITY %	DEDUCT VALUE
L	3	7.7%	13
M	8	6.19%	27
H	5	3%	2
L	12	2.5%	6
TOTAL SEVERITY			
L	6.19'	3%	
M	88'	2.5%	
H	25'		

PCI CALCULATION

DISTRESS TYPE	SEVERITY	DENSITY %	DEDUCT VALUE
1	M	0.2	15
3	H	0.4	14
5	L	0.8	5
8	L	10.7	24
12	L	3.0	6
DEDUCT TOTAL			64
CORRECTED DEDUCT VALUE (COV)			33

PCI = 100 - COV = 67

RATING = GOOD

PCI CALCULATION

DISTRESS TYPE	SEVERITY	DENSITY %	DEDUCT VALUE
3	M	1.8	13
5	L	0.5	2
8	L	12.4	27
8	M	0.5	8
12	L	3.0	6
DEDUCT TOTAL			56
CORRECTED DEDUCT VALUE (COV)			27

PCI = 100 - COV = 73

RATING = VERY GOOD

FLEXIBLE PAVEMENT
CONDITION SURVEY DATA SHEET FOR SAMPLE UNIT

AIRPORT JOHN DAY STATE DATE 4-4-89

FACILITY RUNWAY 9-27 FEATURE R 3 SAMPLE UNIT 1

SURVEYED BY R3/R3 AREA OF SAMPLE 5000

DISTRESS TYPES

- 1. ALLIGATOR CRACKING
- 2. BLEEDING
- 3. BLOCK CRACKING
- 4. CORRUGATION
- 5. DEPRESSION
- 6. JET BLAST
- 7. JT. REFLECTION (POC)
- 8. LONG. & TRANS. CRACKING
- 9. OIL SPILLAGE
- 10. PATCHING
- 11. POLISHED AGGREGATE
- 12. RAVELING/WEATHERING
- 13. RUTTING
- 14. SHOIVING FROM POC
- 15. SLIPPAGE CRACKING
- 16. SWELL

SKETCH:

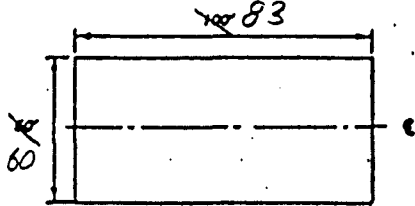

FLEXIBLE PAVEMENT
CONDITION SURVEY DATA SHEET FOR SAMPLE UNIT

AIRPORT _____ DATE _____

FACILITY _____ FEATURE _____ SAMPLE UNIT 2

SURVEYED BY _____ AREA OF SAMPLE _____

DISTRESS TYPES

- 1. ALLIGATOR CRACKING
- 2. BLEEDING
- 3. BLOCK CRACKING
- 4. CORRUGATION
- 5. DEPRESSION
- 6. JET BLAST
- 7. JT. REFLECTION (POC)
- 8. LONG. & TRANS. CRACKING
- 9. OIL SPILLAGE
- 10. PATCHING
- 11. POLISHED AGGREGATE
- 12. RAVELING/WEATHERING
- 13. RUTTING
- 14. SHOIVING FROM POC
- 15. SLIPPAGE CRACKING
- 16. SWELL

SKETCH:

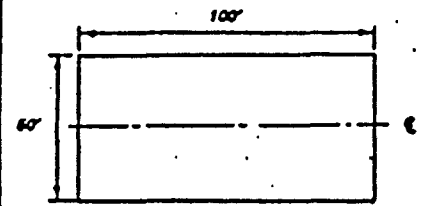

EXISTING DISTRESS TYPES

TOTAL SEVERITY	L	2%								
	M									
	H									
	L									
	M									
	H									
	L									
	M									
	H									
	L									

EXISTING DISTRESS TYPES

TOTAL SEVERITY	L	2%	8							
	M	1 5'	10'							
	H									
	L									
	M									
	H									
	L									
	M									
	H									
	L									

PCI CALCULATION

DISTRESS TYPE	SEVERITY	DENSITY %	DEDUCT VALUE
12	L	2.0	4
DEDUCT TOTAL			4
CORRECTED DEDUCT VALUE (CDV)			4

PCI = 100 - CDV = 96

RATING = EXCELLENT

PCI CALCULATION

DISTRESS TYPE	SEVERITY	DENSITY %	DEDUCT VALUE
8	L	0.2	2
12	L	2.0	4
12	M	0.1	5
DEDUCT TOTAL			11
CORRECTED DEDUCT VALUE (CDV)			11

PCI = 100 - CDV = 89

RATING = EXCELLENT

**TABLE 7-2
ENVIRONMENTAL CHECKLIST**

<u>Potential Impact Category</u>	<u>Existing Conditions/Comments</u>	<u>Agency Advocate Further Analysis, Some Impact Likely?</u>
Wetlands	No wetlands issues pertain to the study area.	NO
Floodplain	Not applicable.	NO
Shoreline Management	Not applicable.	NO
Coastal Barriers	Not applicable.	NO
Wild and Scenic Rivers	Not applicable.	NO
Farmland	Soils on the airport property qualify as prime according to State mandated criteria.	POSSIBLE
Light Emissions and Glare	No analysis of existing light emissions which might pose a potential hazard to aviation, or of nearby uses which might perceive airport lighting as a nuisance, was performed. No such hazards or uses were reported to the consultant by County planning staff, upon inquiry.	NO

**TABLE 7-2
ENVIRONMENTAL CHECKLIST**

Potential Impact Category _____	<u>Existing Conditions/Comments</u>	Agency Advocate Further Analysis, <u>Some Impact Likely?</u>
Energy Supply and Natural Resources	No adverse impacts anticipated.	NO
Solid Waste Impacts	Groundwater systems must be considered and protected during the handling of waste materials at this site. Development would not considerably increase production of waste at the facility.	NO
Construction Impacts	Temporary impacts will accrue during the construction phase. Adherence to the provisions of FAA Circular Advisory 150/5370-10 should preclude foreseeable adverse impacts of construction.	NO

Appendices





United States Department of the Interior

FISH AND WILDLIFE SERVICE
Oregon State Office
2600 S.E. 98th Avenue, Suite 100
Portland, Oregon 97266
(503) 231-6179 FAX: (503) 231-6195

April 27, 1995

In reply refer to: 1-7-95-SP-218

Creed Eckert
Gazeley & Associates
PO Box 81
Halsey, OR 97348

Dear Mr. Eckert:

This is in response to your letter, dated March 31, 1995, requesting information on listed and proposed endangered and threatened species that may be present within the area of the Burns Airport in Harney County and the John Day Airport in Grant County. The U.S. Fish and Wildlife Service (Service) received your letter on 31 March 1995.

We have attached a list (Attachment A) of threatened and endangered species that may occur within the area of the Burns and John Day Airports. The list fulfills the requirement of the Service under section 7(c) of the Endangered Species Act (Act) of 1973, as amended (16 U.S.C. 1531 et seq.). Federal Aviation Administration requirements under the Act are outlined in Attachment B.

The purpose of the Act is to provide a means whereby threatened and endangered species and their ecosystems on which they depend may be conserved. Under section 7(a)(1) and 7(a)(2) of the Act and pursuant to 50 CFR 402 *et seq.*, FAA is required to utilize their authorities to carry out programs which further species conservation and to determine whether projects may affect threatened and endangered species, and/or critical habitat. A Biological Assessment is required for construction projects (or other undertakings having similar physical impacts) which are major Federal actions significantly affecting the quality of the human environment as defined in NEPA (42 U.S.C. 4332 (2)(c)). For projects other than major construction activities, the Service suggests that a biological evaluation similar to the Biological Assessment be prepared to determine whether they may affect listed and proposed species. Recommended contents of a Biological Assessment are described in Attachment B, as well as 50 CFR 401.12.

If FAA determines, based on the Biological Assessment or evaluation, that threatened and endangered species and/or critical habitat may be affected by the project, FAA is required to consult with the Service following the requirements of 50 CFR 402 which implement the Act.

Attachment A includes a list of candidate species under review for listing. These candidate species have no protection under the Act but are included for consideration as it is possible candidates could be listed prior to project completion. Thus, if a proposed project may affect candidate species, FAA is not required to perform a Biological Assessment or evaluation or consult with the Service. However, the Service recommends addressing potential impacts to candidate species in order to prevent future conflicts. Therefore, if early evaluation of the project indicates that it is likely to adversely impact a candidate species, FAA may wish to request technical assistance from this office.

Your interest in endangered species is appreciated. The Service encourages FAA to investigate opportunities for incorporating conservation of threatened and endangered species into project planning processes as a means of

complying with the Act. If you have questions regarding your responsibilities under the Act, please contact Rollie White at (503) 231-6179. All correspondence should include the above referenced case number.

Sincerely,

Russell D. Peterson
for Russell D. Peterson
State Supervisor

Attachments

SP 218

cc: PFO-ES

ODFW (nongame)

FAA

FEDERALLY LISTED AND PROPOSED ENDANGERED AND THREATENED SPECIES AND
 CANDIDATE SPECIES THAT MAY OCCUR IN THE AREA OF THE PROPOSED
 JOHN DAY AIRPORT PROJECT
 1-7-95-SP-218B

LISTED SPECIES^{1/}Birds

Bald eagle	<i>Haliaeetus leucocephalus</i>	LT
------------	---------------------------------	----

PROPOSED SPECIES[/]

None

CANDIDATE SPECIES^{2,3/}Mammals

Pygmy rabbit	<i>Brachylagus idahoensis</i>	C2
Long-eared myotis (bat)	<i>Myotis evotis</i>	C2
Long-legged myotis (bat)	<i>Myotis volans</i>	C2
Yuma myotis (bat)	<i>Myotis yumanensis</i>	C2
Pacific western big-eared bat	<i>Plecotus townsendii townsendii</i>	C2

Birds

Western burrowing owl	<i>Athene cunicularia hypugea</i>	C2
Ferruginous hawk	<i>Buteo regalis</i>	C2

Plants

Arrow-leaf thelypody	<i>Thelypodium eucosum</i>	C2
Historical collection, Canyonville, 1885		

(LE) - Listed Endangered (LT) - Listed Threatened (CH) - Critical Habitat has been designated for this species
 (PE) - Proposed Endangered (PT) - Proposed Threatened (PCH) - Critical Habitat has been proposed for this species
 (S) - Suspected (D) - Documented

- (C1)- Category 1: Taxa for which the Fish and Wildlife Service has sufficient biological information to support a proposal to list as endangered or threatened.
 (C2)- Category 2: Taxa for which existing information indicates may warrant listing, but for which substantial biological information to support a proposed rule is lacking.
 (3A)- Category 3A: Taxa for which the Service has persuasive evidence of extinction.
 (3B)- Category 3B: Names that on the basis of current taxonomic understanding do not represent taxa meeting the Act's definition of "species."
 (3C)- Category 3C: Taxa that have proven to be more abundant or widespread than was previously believed and/or those that are not subject to any identifiable threat.

* If a vertebrate or plant, a single asterisk indicates taxon is possibly extinct. If an invertebrate, a single asterisk indicates a lack of information for the taxon since 1963.

** Consultation with National Marine Fisheries Service required.

- ^{1/} U. S. Department of Interior, Fish and Wildlife Service, August 23, 1993, Endangered and Threatened Wildlife and Plants, 50 CFR 17.11 and 17.12.
- ^{2/} Federal Register Vol. 59, No. 219, November 15, 1994, Notice of Review-Animals
- ^{3/} Federal Register Vol. 58, No. 188, September 30, 1993, Notice of Review-Plants

FEDERAL AGENCIES RESPONSIBILITIES UNDER SECTIONS 7(a) and (c)
OF THE ENDANGERED SPECIES ACT

SECTION 7(a) - Consultation/Conference

Requires: 1) Federal agencies to utilize their authorities to carry out programs to conserve endangered and threatened species;

2) Consultation with FWS when a Federal action may affect a listed endangered or threatened species to insure that any action authorized, funded or carried out by a Federal agency is not likely to jeopardize the continued existence of listed species or result in the destruction or adverse modification of Critical Habitat. The process is initiated by the Federal agency after they have determined if their action may affect (adversely or beneficially) a listed species; and

3) Conference with FWS when a Federal action is likely to jeopardize the continued existence of a proposed species or result in destruction or adverse modification of proposed Critical Habitat.

SECTION 7(c) - Biological Assessment for Major Construction Projects ^{1/}

Requires Federal agencies or their designees to prepare a Biological Assessment (BA) for construction projects only. The purpose of the BA is to identify any proposed and/or listed species which are/is likely to be affected by a construction project. The process is initiated by a Federal agency in requesting a list of proposed and listed threatened and endangered species (list attached). The BA should be completed within 180 days after its initiation (or within such a time period as is mutually agreeable). If the BA is not initiated within 90 days of receipt of the species list, the accuracy of the species list should be informally verified with our Service. No irreversible commitment of resources is to be made during the BA process which would foreclose reasonable and prudent alternatives to protect endangered species. Planning, design, and administrative actions may be taken; however, no construction may begin.

To complete the BA, your agency or its designee should: (1) conduct an on-site inspection of the area to be affected by the proposal which may include a detailed survey of the area to determine if the species is present and whether suitable habitat exists for either expanding the existing population or for potential reintroduction of the species; (2) review literature and scientific data to determine species distribution, habitat needs, and other biological requirements; (3) interview experts including those within FWS, National Marine Fisheries Service, State conservation departments, universities, and others who may have data not yet published in scientific literature; (4) review and analyze the effects of the proposal on the species in terms of individuals and populations, including consideration of cumulative effects of the proposal on the species and its habitat; (5) analyze alternative actions that may provide conservation measures and (6) prepare a report documenting the results, including a discussion of study methods used, any problems encountered, and other relevant information. The BA should conclude whether or not a listed or proposed species will be affected. Upon completion, the report should be forwarded to our Portland Office.

^{1/}A construction project (or other undertaking having similar physical impacts) which is a major Federal action significantly affecting the quality of the human environment as referred to in NEPA (42 U.S.C. 4332.(2)c). On projects other than construction, it is suggested that a biological evaluation similar to the biological assessment be undertaken to conserve species influenced by the Endangered Species Act.

April 12, 1995

Creed Eckert
Gazeley & Associates
10880 SW Matzen Drive
Wilsonville, OR 97070

RE: Burns Airport (Harney Co)
John Day Airport (Grant Co)
Cultural resources

Dear Mr Eckert:

Sorry to be so slow, but things are backing up again, and we try to be fair by having a first-in, first-serve policy. There are no surveys and no sites in either of the project areas. There are a number of historic mining sites around John Day & Canyon City relating to the mining boom.

If you need further information you can contact me at (503) 378-6508 ext 232.

Sincerely,

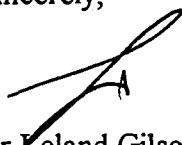

Dr Leland Gilson
SHPO Archaeologist



PCI REPORT

Site Name : ODOT-Aeronautics Section - John Day State Airport
 Database Name : C:JOHNDAY Report Date: JUN/30/1995

Network ID: All
 Branch Number: All
 Section Number: All
 Branch Use: All
 Surface Type: All
 Pavement Rank: All
 Zone: All
 Section Category: All
 Section Area: All
 Last Construction Date: All
 Last Inspection Date: All
 PCI: All

Network ID	Branch Number	Section Name	Num/Rank/Surf/Length(LF)/Area(SF)	Last Construct Date	Last Inspection Date	PCI
00028	A03JD	APRON 03 JOHN DAY	01 / S / ST / 268.00/ 10720.00	AUG/01/1992	JUN/26/1994	100
		APRON	From: See Map			
					Age (Yrs): 1.9	
00028	A04JD	APRON 04 JOHN DAY	01 / S / AC / 226.00/ 36612.00	AUG/01/1992	JUN/26/1994	100
		APRON	From: See Map			
					Age (Yrs): 1.9	
00028	T07JD	TAXIWAY 07 JOHN DAY	01 / S / AC / 85.00/ 5361.00	AUG/01/1992	JUN/26/1994	100
		TAXIWAY	From: T01JD			
					Age (Yrs): 1.9	
00028	R09JD	RUNWAY 09/27 JOHN DAY	02 / S / ST / 98.00/ 6073.00	AUG/01/1992	JUN/26/1994	98
		RUNWAY	From: Hold Apron R09 End			
					Age (Yrs): 1.9	
00028	R09JD	RUNWAY 09/27 JOHN DAY	01 / S / AC / 3410.00/ 205348.00	AUG/01/1992	JUN/26/1994	90
		RUNWAY	From: R09 End			
					Age (Yrs): 1.9	
00028	T04JD	TAXIWAY 04 JOHN DAY	01 / P / AC / 219.00/ 8157.00	AUG/01/1980	JUN/26/1994	87
		TAXIWAY	From: R34/R27 Intersection			
					Age (Yrs):13.9	
00028	T02JD	TAXIWAY 02 JOHN DAY	02 / S / AC / 245.00/ 7447.00	AUG/01/1962	JUN/26/1994	80
		TAXIWAY	From: T01JD			
					Age (Yrs):31.9	
00028	T02JD	TAXIWAY 02 JOHN DAY	01 / S / AC / 245.00/ 7447.00	AUG/01/1979	JUN/26/1994	75
		TAXIWAY	From: T01JD			
					Age (Yrs):14.9	
00028	T02JD	TAXIWAY 02 JOHN DAY	04 / S / ST / 248.00/ 5193.00	AUG/01/1962	JUN/26/1994	74
		TAXIWAY	From: T06JD			
					Age (Yrs):31.9	
00028	T05JD	TAXIWAY 05 JOHN DAY	01 / P / AC / 129.00/ 3980.00	AUG/01/1962	JUN/26/1994	74
		TAXIWAY	From: T01JD			
					Age (Yrs):31.9	

FLEXIBLE PAVEMENT
CONDITION SURVEY DATA SHEET FOR SAMPLE UNIT

AIRPORT JOHN DAY STATE DATE _____

FACILITY RUNWAY 9-27 FEATURE R3 SAMPLE UNIT 5

SURVEYED BY RB/RS AREA OF SAMPLE 5000

DISTRESS TYPES

- 1. ALLIGATOR CRACKING
- 2. BLEEDING
- 3. BLOCK CRACKING
- 4. CORRUGATION
- 5. DEPRESSION
- 6. JET BLAST
- 7. JT. REFLECTION (POC)
- 8. LONG. & TRANS. CRACKING
- 9. OIL SPILLAGE
- 10. PATCHING
- 11. POLISHED AGGREGATE
- 12. RAVELING/WEATHERING
- 13. RUTTING
- 14. SHOIVING FROM POC
- 15. SLIPPAGE CRACKING
- 16. SWELL

SKETCH:

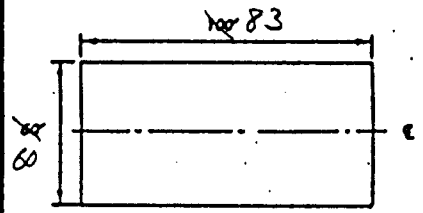

EXISTING DISTRESS TYPES

TOTAL SEVERITY	L	12							
	M	2 1/2							
	S	15'							

PCI CALCULATION

DISTRESS TYPE	SEVERITY	DENSITY %	DEDUCT VALUE
12	L	2.0	4
12	M	0.1	5
DEDUCT TOTAL			9
CORRECTED DEDUCT VALUE (CDV)			4

PCI = 100 - CDV = 91

RATING = EXCELLENT

FLEXIBLE PAVEMENT
CONDITION SURVEY DATA SHEET FOR SAMPLE UNIT

AIRPORT _____ DATE _____

FACILITY _____ FEATURE _____ SAMPLE UNIT 6

SURVEYED BY _____ AREA OF SAMPLE _____

DISTRESS TYPES

- 1. ALLIGATOR CRACKING
- 2. BLEEDING
- 3. BLOCK CRACKING
- 4. CORRUGATION
- 5. DEPRESSION
- 6. JET BLAST
- 7. JT. REFLECTION (POC)
- 8. LONG. & TRANS. CRACKING
- 9. OIL SPILLAGE
- 10. PATCHING
- 11. POLISHED AGGREGATE
- 12. RAVELING/WEATHERING
- 13. RUTTING
- 14. SHOIVING FROM POC
- 15. SLIPPAGE CRACKING
- 16. SWELL

SKETCH:

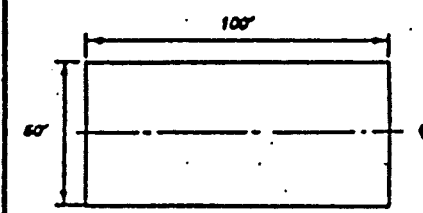

EXISTING DISTRESS TYPES

TOTAL SEVERITY	L	12							
	M	2 1/2							
	S								

PCI CALCULATION

DISTRESS TYPE	SEVERITY	DENSITY %	DEDUCT VALUE
12	L	2.0	4
DEDUCT TOTAL			4
CORRECTED DEDUCT VALUE (CDV)			4

PCI = 100 - CDV = 96

RATING = EXCELLENT

FLEXIBLE PAVEMENT
CONDITION SURVEY DATA SHEET FOR SAMPLE UNIT

AIRPORT JOHN DAY STATE DATE 4-4-89

FACILITY TAXIWAY FEATURE TI SAMPLE UNIT 1

SURVEYED BY RR/RB AREA OF SAMPLE 5000

DISTRESS TYPES

- 1. ALLIGATOR CRACKING
- 2. BLEEDING
- 3. BLOCK CRACKING
- 4. CORRUGATION
- 5. DEPRESSION
- 6. JET BLAST
- 7. JT. REFLECTION (PCI)
- 8. LONG. & TRANS. CRACKING
- 9. OIL SPILLAGE
- 10. PATCHING
- 11. POLISHED AGGREGATE
- 12. RAVELING/WEATHERING
- 13. RUTTING
- 14. SHOIVING FROM PCC
- 15. SLIPPAGE CRACKING
- 16. SWELL

SKETCH:

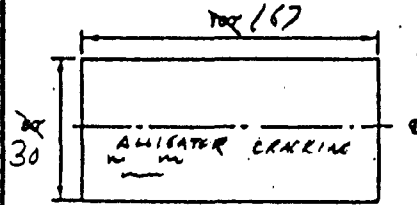

FLEXIBLE PAVEMENT
CONDITION SURVEY DATA SHEET FOR SAMPLE UNIT

AIRPORT _____ DATE _____

FACILITY _____ FEATURE _____ SAMPLE UNIT 2

SURVEYED BY _____ AREA OF SAMPLE _____

DISTRESS TYPES

- 1. ALLIGATOR CRACKING
- 2. BLEEDING
- 3. BLOCK CRACKING
- 4. CORRUGATION
- 5. DEPRESSION
- 6. JET BLAST
- 7. JT. REFLECTION (PCI)
- 8. LONG. & TRANS. CRACKING
- 9. OIL SPILLAGE
- 10. PATCHING
- 11. POLISHED AGGREGATE
- 12. RAVELING/WEATHERING
- 13. RUTTING
- 14. SHOIVING FROM PCC
- 15. SLIPPAGE CRACKING
- 16. SWELL

SKETCH:

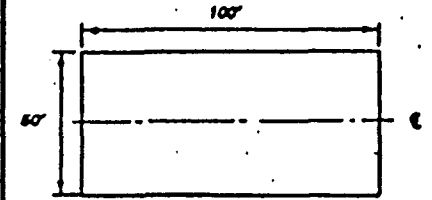

EXISTING DISTRESS TYPES

3	1	8	5	12
58m	36L	958L	40L	30%L
	46L			
	20L			

TOTAL SEVERITY	L	96	5	958	40	3%
	M	58				
	N					

PCI CALCULATION

DISTRESS TYPE	SEVERITY	DENSITY %	DEDUCT VALUE
1	L	1.9	27
3	M	1.2	12
5	L	0.8	5
8	L	19.2	32
12	L	3.0	6
DEDUCT TOTAL			82
CORRECTED DEDUCT VALUE (CDV)			43

PCI = 100 - CDV = 57

RATING = GOOD

EXISTING DISTRESS TYPES

3	8	5	12
40m	566L	90L	30%L
87m			

TOTAL SEVERITY	L	546	90	3%
	M	127		
	N			

PCI CALCULATION

DISTRESS TYPE	SEVERITY	DENSITY %	DEDUCT VALUE
3	L	2.5	10
5	L	1.8	10
8	L	11.3	25
12	L	3.0	6
DEDUCT TOTAL			51
CORRECTED DEDUCT VALUE (CDV)			24

PCI = 100 - CDV = 76

RATING = VERY GOOD

FLEXIBLE PAVEMENT

CONDITION SURVEY DATA SHEET FOR SAMPLE UNIT

AIRPORT **JOHN DAY STATE** DATE **4-4-81**
 FACILITY **TAXIWAY** FEATURE **T1** SAMPLE UNIT **3**
 SURVEYED BY **RB/RB** AREA OF SAMPLE **5000**

DISTRESS TYPES

- 1. ALLIGATOR CRACKING
- 2. BLEEDING
- 3. BLOCK CRACKING
- 4. CORRUGATION
- 5. DEPRESSION
- 6. JET BLAST
- 7. JT. REFLECTION (POC)
- 8. LONG. & TRANS. CRACKING
- 9. OIL SPILLAGE
- 10. PATCHING
- 11. POLISHED AGGREGATE
- 12. RAVELING/WEATHERING
- 13. RUTTING
- 14. SHOIVING FROM PCC
- 15. SLIPPAGE CRACKING
- 16. SWELL

SKETCH:

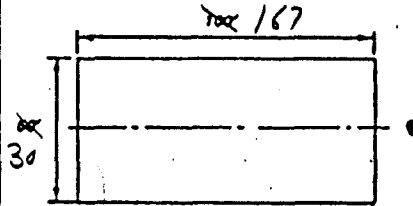

FLEXIBLE PAVEMENT

CONDITION SURVEY DATA SHEET FOR SAMPLE UNIT

AIRPORT _____ DATE _____
 FACILITY _____ FEATURE _____ SAMPLE UNIT **4**
 SURVEYED BY _____ AREA OF SAMPLE _____

DISTRESS TYPES

- 1. ALLIGATOR CRACKING
- 2. BLEEDING
- 3. BLOCK CRACKING
- 4. CORRUGATION
- 5. DEPRESSION
- 6. JET BLAST
- 7. JT. REFLECTION (POC)
- 8. LONG. & TRANS. CRACKING
- 9. OIL SPILLAGE
- 10. PATCHING
- 11. POLISHED AGGREGATE
- 12. RAVELING/WEATHERING
- 13. RUTTING
- 14. SHOIVING FROM PCC
- 15. SLIPPAGE CRACKING
- 16. SWELL

SKETCH:

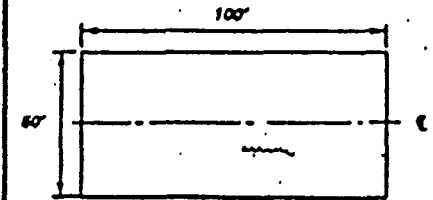

EXISTING DISTRESS TYPES

	2	10	5	12		
	599 L	35 L	20 L	3% L		
			15 L			
			20 L			
			35 H			
			20 L			
TOTAL SEVERITY	L	599'	35s	75s	3%	
	H		35s			

EXISTING DISTRESS TYPES

	8	17	3	1		
	790 L	30% L	127 M	30 L		
TOTAL SEVERITY	L	790'	3%	127s	30s	
	H					

PCI CALCULATION

DISTRESS TYPE	SEVERITY	DENSITY %	DEDUCT VALUE
5	L	1.5	9
5	M	0.7	13
8	L	12.0	26
10	L	0.7	3
12	L	3.0	6
DEDUCT TOTAL			57
CORRECTED DEDUCT VALUE (COV)			29

PCI = 100 - COV = 71

RATING = VERY GOOD

PCI CALCULATION

DISTRESS TYPE	SEVERITY	DENSITY %	DEDUCT VALUE
1	L	0.6	17
3	M	2.5	15
8	L	15.8	30
12	L	3.0	6
DEDUCT TOTAL			68
CORRECTED DEDUCT VALUE (COV)			35

PCI = 100 - COV = 65

RATING = GOOD

FLEXIBLE PAVEMENT
CONDITION SURVEY DATA SHEET FOR SAMPLE UNIT

AIRPORT JOHN DAY STATE DATE 4-4-89
 FACILITY APRON FEATURE A1 SAMPLE UNIT 1

SURVEYED BY RB/RB AREA OF SAMPLE 5000

DISTRESS TYPES

- | | |
|----------------------------|-------------------------|
| 1. ALLIGATOR CRACKING | 10. PATCHING |
| 2. BLEEDING | 11. POLISHED AGGREGATE |
| 3. BLOCK CRACKING | 12. RAVELING/WEATHERING |
| 4. CORRUGATION | 13. RUTTING |
| 5. DEPRESSION | 14. SHOIVING FROM POC |
| 6. JET BLAST | 15. SLIPPAGE CRACKING |
| 7. JT. REFLECTION (POC) | 16. SWELL |
| 8. LONG. & TRANS. CRACKING | |
| 9. OIL SPILLAGE | |

SKETCH:

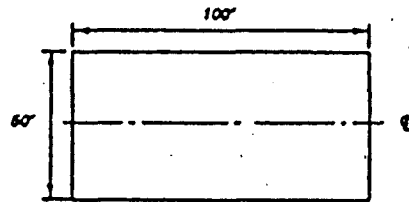

FLEXIBLE PAVEMENT
CONDITION SURVEY DATA SHEET FOR SAMPLE UNIT

AIRPORT _____ DATE _____
 FACILITY _____ FEATURE _____ SAMPLE UNIT 2

SURVEYED BY _____ AREA OF SAMPLE _____

DISTRESS TYPES

- | | |
|----------------------------|-------------------------|
| 1. ALLIGATOR CRACKING | 10. PATCHING |
| 2. BLEEDING | 11. POLISHED AGGREGATE |
| 3. BLOCK CRACKING | 12. RAVELING/WEATHERING |
| 4. CORRUGATION | 13. RUTTING |
| 5. DEPRESSION | 14. SHOIVING FROM POC |
| 6. JET BLAST | 15. SLIPPAGE CRACKING |
| 7. JT. REFLECTION (POC) | 16. SWELL |
| 8. LONG. & TRANS. CRACKING | |
| 9. OIL SPILLAGE | |

SKETCH:

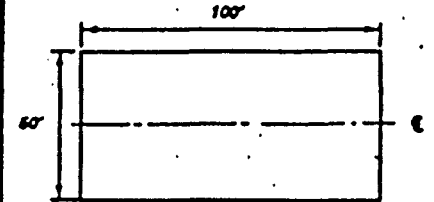

EXISTING DISTRESS TYPES

8	5	1	9	12	
140 L	40 L	14 L	40 s	3% L	
177 m	30 L	14 m			
398 L	60 L	24 L			
	70 L	15 L			
	20 L				
	45 L				

EXISTING DISTRESS TYPES

10	8	5	12	9	1
5 m	25 m	40 L	3% L	30	20 L
20 m	594 L	50 L			
1 m		20 L			
10 m					

TOTAL SEVERITY	L	538'	265'	53 s'	40 s'	3%
	M	177'		14 s'		
	H					

TOTAL SEVERITY	L	594'	110 s'	3%	30 s'	20 s'
	M	36 s'	75'			
	H					

PCI CALCULATION

DISTRESS TYPE	SEVERITY	DENSITY %	DEDUCT VALUE
1	L	1.1	22
5	L	5.3	20
8	L	10.8	24
7	M	3.5	21
4		0.8	4
12	L	3.0	6
1	M	0.3	18
DEDUCT TOTAL			115
CORRECTED DEDUCT VALUE (COV)			58

PCI = 100 - COV = 42

RATING = FAIR

PCI CALCULATION

DISTRESS TYPE	SEVERITY	DENSITY %	DEDUCT VALUE
1	L	0.4	13
5	L	2.2	12
8	L	11.9	25
8	M	0.5	8
9		0.6	3
10	M	0.7	9
12	L	3.0	6
DEDUCT TOTAL			76
CORRECTED DEDUCT VALUE (COV)			40

PCI = 100 - COV = 60

RATING = GOOD

FLEXIBLE PAVEMENT
CONDITION SURVEY DATA SHEET FOR SAMPLE UNIT

AIRPORT JOHN DAY STATE DATE 4-4-89

FACILITY APRIN FEATURE A1 SAMPLE UNIT 3

SURVEYED BY RB/RB AREA OF SAMPLE 5000

- DISTRESS TYPES**
- 1. ALLIGATOR CRACKING
 - 2. BLEEDING
 - 3. BLOCK CRACKING
 - 4. CORRUGATION
 - 5. DEPRESSION
 - 6. JET BLAST
 - 7. JT. REFLECTION (POC)
 - 8. LONG. & TRANS. CRACKING
 - 9. OIL SPILLAGE
 - 10. PATCHING
 - 11. POLISHED AGGREGATE
 - 12. RAVELING/WEATHERING
 - 13. RUTTING
 - 14. SHOIVING FROM POC
 - 15. SLIPPAGE CRACKING
 - 16. SWELL

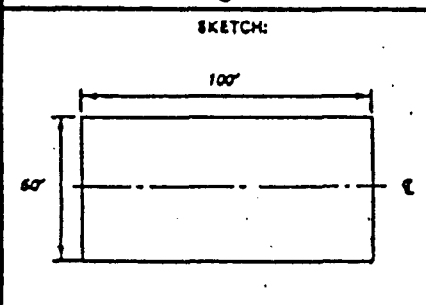

FLEXIBLE PAVEMENT
CONDITION SURVEY DATA SHEET FOR SAMPLE UNIT

AIRPORT DATE

FACILITY FEATURE SAMPLE UNIT 4

SURVEYED BY AREA OF SAMPLE

- DISTRESS TYPES**
- 1. ALLIGATOR CRACKING
 - 2. BLEEDING
 - 3. BLOCK CRACKING
 - 4. CORRUGATION
 - 5. DEPRESSION
 - 6. JET BLAST
 - 7. JT. REFLECTION (POC)
 - 8. LONG. & TRANS. CRACKING
 - 9. OIL SPILLAGE
 - 10. PATCHING
 - 11. POLISHED AGGREGATE
 - 12. RAVELING/WEATHERING
 - 13. RUTTING
 - 14. SHOIVING FROM POC
 - 15. SLIPPAGE CRACKING
 - 16. SWELL

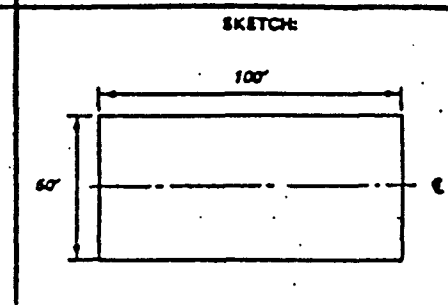

EXISTING DISTRESS TYPES

	1	10	3	8	12	5
	106 m	380 m	200 m	280 L	3% L	60 L
	44 m			328 m		50 L
	40 m					40 L
	30 m					40 L
						35 L
						40 L
TOTAL SEVERITY	L			280'	3%	265'
	E	2205'	380 s	200 s	328'	
	H					

EXISTING DISTRESS TYPES

	8	9	5	12		
	338 L	40 s	40 L	3% L		
			60 L			
			45 L			
TOTAL SEVERITY	L	338'	40 s	145 s	3%	
	E					
	H					

PCI CALCULATION

DISTRESS TYPE	SEVERITY	DENSITY %	DEDUCT VALUE
1	M	4.4	45
3	M	4.0	18
5	L	10.3	28
8	L	5.6	15
8	M	6.6	28
9		0.6	3
10	M	7.6	26
DEDUCT TOTAL			169
CORRECTED DEDUCT VALUE (COV)			76

PCI = 100 - COV = 24

RATING = VERY POOR

PCI CALCULATION

DISTRESS TYPE	SEVERITY	DENSITY %	DEDUCT VALUE
5	L	2.9	14
8	L	6.8	17
9		0.8	4
12	L	3.0	6
DEDUCT TOTAL			41
CORRECTED DEDUCT VALUE (COV)			23

PCI = 100 - COV = 78

RATING = VERY GOOD

L 3.0 6

John Day State Airport

Pavement Development and Maintenance

This airport was constructed as a FAAP project in 1962 consisting of the N-S runway 4500' x 50', the parallel taxiway, apron and its associated taxiways. In 1982, the crosswind E-W runway was paved 3436' x 60' using a cold mix AC surface. Crackfilling of the N-S runway/taxiway complex has been accomplished 4 times by State Aeronautics Division, most recently in 1987, and the runway had one application of reclamite. The original pavements have been well maintained but are now 27 years old.

Runway 16-34 is the primary runway at 4500' x 50' and it is in good to very good condition. Cracks are the main problem and many of the transverse cracks are very wide in the 3/4" to 1½" range. The longitudinal cracks are mainly in the paving lane joints. The 1987 crackfilling project was very effective in sealing all cracks including the very wide transverse cracks. There is a lot of block cracking developing in the edges for about a 1' wide band along both sides. Also, some aggregate particles are popping out of the surface and there is a general weathering of the 27 year old surface. Conditions along the parallel taxiway are generally quite similar but it only rates good and there are a number of alligator cracked areas. It is suggested that the runway have a slurry seal sometime in the next few years. An overlay of the runway should probably be tied in with a future widening project. The taxiway could use repair of the alligatored areas plus an overlay sometime in the next few years.

The new runway 9-27 is in fine shape but there are quite a few small loose aggregate particles on the surface. Also, in a number of places pieces of the surface have ravelled or come out. These are generally about 6" in diameter and were most likely caused by turning aircraft when the pavement was reasonably new. Neither of these conditions appear serious but another fog coat would be desirable in the next 2 or 3 years. There are only a very few fine cracks evident.

John Day State
Overall Planning and Development

This is a very complete general aviation facility for the area. With two paved and lighted runways and a full parallel taxiway, not much is needed in the future other than pavement maintenance and improvement. Ample room for additional buildings exists.

Probably a modest expansion of the terminal area to the north would be desirable sometime in the next 10 years. Also, overlay of the terminal apron is recommended. For other pavement improvements see the pavement report.

The new crosswind runway is very nice but 16-34 appears to be favored even when the wind is not on it and it is 10' narrower than 9-27. Convenience to the terminal seems to dictate.

JOHN DAY STATE AIRPORT

PRINCIPAL DISTRESSES:

RUNWAY 16-34 R-1 Longitudinal and transverse cracking with block
cracking at edges plus weathering and a few
depressions

RUNWAY 9-27 R-3 Raveling/weathering

TAXIWAY T-1 Alligator, longitudinal and transverse cracking with
block cracking at edges plus weathering and depressions

APRON A-1 Alligator, longitudinal and transverse cracking plus
depressions and weathering

The apron shows more distress with a lot of cracks, some patching, and a few failed areas. Reconstruction and an overlay of this apron is needed in the next couple of years. The southwest third of the apron is particularly bad.

SUGGESTED PAVEMENT PROGRAM:

Runway 16-34 4500' x 50'

Slurry seal 25,000 S.Y. @ \$ 1.60	= \$ 40,000.00
Basic marking 4500' @ \$1.67	= \$ 7,500.00

Parallel taxiway 5000' x 30'

Overlay with fabric 16,666 S.Y. @ \$7.50	= \$125,000.00
Repair of bad areas	\$ 5,000.00
Marking 5000' @ \$.50	= \$ 2,500.00

Runway 9-27 3435' x 60'

Fog seal 22,906 S.Y. @ \$.25	= \$ 6,000.00
------------------------------	---------------

Apron 200' x 225'

Repair of bad areas	\$ 5,000.00
3" AC overlay with fabric 5,000 S.Y. @ \$8.00	= \$ 40,000.00

AIRPORT AND RUNWAY DATA

Airport elevation	3697 feet
Mean daily maximum temperature of the hottest month	90.30 F.
Maximum difference in runway centerline elevation	23 feet
Length of haul for airplanes of more than 60,000 pounds	500 miles
Wet and slippery runways	

RUNWAY LENGTHS RECOMMENDED FOR AIRPORT DESIGN

Small airplanes with approach speeds of less than 30 knots . . .	410 feet
Small airplanes with approach speeds of less than 50 knots . . .	1100 feet
Small airplanes with less than 10 passenger seats	
75 percent of these small airplanes	3880 feet
95 percent of these small airplanes	4970 feet
100 percent of these small airplanes	5340 feet
Small airplanes with 10 or more passenger seats	5340 feet
Large airplanes of 60,000 pounds or less	
75 percent of these large airplanes at 60 percent useful load	6240 feet
75 percent of these large airplanes at 90 percent useful load	8830 feet
100 percent of these large airplanes at 60 percent useful load	8040 feet
100 percent of these large airplanes at 90 percent useful load	9780 feet
Airplanes of more than 60,000 pounds	Approximately 6310 feet

REFERENCE: Chapter 2 of AC 150/5325-4A, Runway Length Requirements for Airport Design, no Changes included.

AIRPORT DESIGN AIRPLANE AND AIRPORT DATA

Aircraft Approach Category B	
Airplane Design Group II	
Airplane wingspan	53.50 feet
Primary runway end is nonprecision instrument > 3/4-statute mile	
Other runway end is visual	
Airplane undercarriage width (1.15 x main gear track) . . .	13.00 feet
Airport elevation	3697 feet

RUNWAY AND TAXIWAY WIDTH AND CLEARANCE STANDARD DIMENSIONS

Airplane Group/ARC

Runway centerline to parallel runway centerline simultaneous operations
when wake turbulence is not treated as a factor:

VFR operations	700 feet
VFR operations with intervening taxiway	700 feet
VFR operations with two intervening taxiways	700 feet
IFR approach and departure with approach to near threshold	2500 feet less
100 ft for each 500 ft of threshold stagger to a minimum of 1000 ft.	

Runway centerline to parallel runway centerline simultaneous operations
when wake turbulence is a factor:

VFR operations	2500 feet
IFR departures	2500 feet
IFR approach and departure with approach to near threshold . .	2500 feet
IFR approach and departure with approach to far threshold	2500 feet plus
100 feet for each 500 feet of threshold stagger.	
IFR approaches	3400 feet

Runway centerline to parallel taxiway/taxilane centerline .	226.7	240 feet
Runway centerline to edge of aircraft parking	250.0	250 feet
Taxiway centerline to parallel taxiway/taxilane centerline	74.2	105 feet
Taxiway centerline to fixed or movable object	47.5	65.5 feet
Taxilane centerline to parallel taxilane centerline	68.8	97 feet
Taxilane centerline to fixed or movable object	42.1	57.5 feet

Runway protection zone at the primary runway end:

Length	1700 feet
Width 200 feet from runway end	500 feet
Width 1900 feet from runway end	1010 feet

Runway protection zone at other runway end:

Length	1000 feet
Width 200 feet from runway end	500 feet
Width 1200 feet from runway end	700 feet

Departure runway protection zone:

Length	1000 feet
Width 200 feet from the far end of TORA	500 feet
Width 1200 feet from the far end of TORA	700 feet

Runway obstacle free zone (OFZ) width	400.0	400 feet
Runway obstacle free zone length beyond each runway end		200 feet
Approach obstacle free zone width	400.0	400 feet

Approach obstacle free zone length beyond approach light system		200 feet
Approach obstacle free zone slope from 200 feet beyond threshold		50:1
Inner-transitional surface obstacle free zone slope		0:1
Runway width		75 feet
Runway shoulder width		10 feet
Runway blast pad width		95 feet
Runway blast pad length		150 feet
Runway safety area width		150 feet
Runway safety area length beyond each runway end or stopway end, whichever is greater		300 feet
Runway object free area width		500 feet
Runway object free area length beyond each runway end or stopway end, whichever is greater		600 feet
Clearway width		500 feet
Stopway width		75 feet
Taxiway width	28.0	35 feet
Taxiway edge safety margin		7.5 feet
Taxiway shoulder width		10 feet
Taxiway safety area width	53.5	79 feet
Taxiway object free area width	94.9	131 feet
Taxilane object free area width	84.2	115 feet
Taxiway wingtip clearance	20.7	26 feet
Taxilane wingtip clearance	15.4	18 feet

Threshold surface at primary runway end:

Distance out from threshold to start of surface		0 feet
Width of surface at start of trapezoidal section		400 feet
Width of surface at end of trapezoidal section		1000 feet
Length of trapezoidal section		1500 feet
Length of rectangular section		8500 feet
Slope of surface		20:1

Threshold surface at other runway end:

Distance out from threshold to start of surface		0 feet
Width of surface at start of trapezoidal section		400 feet
Width of surface at end of trapezoidal section		1000 feet
Length of trapezoidal section		1500 feet
Length of rectangular section		8500 feet
Slope of surface		20:1

REFERENCE: AC 150/5300-13, Airport Design, including Changes 1 through 3.