

**PRECAST CONCRETE  
BARRIER CRASH TESTING**

**Final Report**

**SPR 330**



# **PRECAST CONCRETE BARRIER CRASH TESTING**

## **Final Report**

**SPR 330**

by

Daniel J. MacDonald, Standards Engineer  
Roadway Engineering Section  
ODOT Highway Division

and

Alan R. Kirk, Research Analyst  
Research Group  
ODOT Transportation Development Division

for

Oregon Department of Transportation  
Research Group  
200 Hawthorne SE, Suite B-240  
Salem OR 97301-5192

and

Federal Highway Administration  
Washington, D.C.

**December 2001**



Technical Report Documentation Page

1. Report No.  FHWA-OR-RD-02-07		2. Government Accession No.		3. Recipient's Catalog No.	
4. Title and Subtitle  Precast Concrete Barrier Crash Testing - Final Report				5. Report Date  December 2001	
				6. Performing Organization Code	
7. Author(s)  Daniel J. MacDonald, Standards Engineer (Principal Investigator) Roadway Engineering Section, ODOT Highway Division and Alan R. Kirk, Research Analyst Research Group, ODOT Transportation Development Division				8. Performing Organization Report No.	
9. Performing Organization Name and Address  Oregon Department of Transportation Research Group 200 Hawthorne Ave. SE, Suite B-240 Salem, OR 97301-5192				10. Work Unit No. (TRAIS)	
				11. Contract or Grant No.  SPR 330	
12. Sponsoring Agency Name and Address  Oregon Department of Transportation      Federal Highway Administration Research Group                                      and 400 Seventh Street SW 200 Hawthorne Ave. SE, Suite B-240      Washington, DC 20590 Salem, OR 97301-5192				13. Type of Report and Period Covered  Final Report	
				14. Sponsoring Agency Code	
15. Supplementary Notes					
16. Abstract  The objectives of this project were to crash test the Oregon Standard (32-inch) F-shape precast concrete barrier and the Oregon Tall (42-inch) F-shape precast concrete barrier against the new NCHRP Report 350 standards, to ensure compliance of these safety systems. FHWA has required that such systems are acceptable under NCHRP standards by no later than October 2002. The results of the Test Level 3 crash tests showed that both barriers meet NCHRP requirements. Furthermore, FHWA acknowledged both barriers as having the best performance of any free-standing precast concrete barriers to date. The research report also discusses the performance of the Tall F-shape barrier in a Test Level 4 crash test, involving an 8,000 kg single-unit truck. The barrier passed this test as well.					
17. Key Words  precast concrete barrier, temporary concrete barrier, median barrier, crash test, NCHRP Report 350			18. Distribution Statement  Available from NTIS      and from Oregon Department of Transportation ( <a href="http://www.odot.state.or.us/tddresearch">http://www.odot.state.or.us/tddresearch</a> )		
19. Security Classification (of this report)  Unclassified		20. Security Classification (of this page)  Unclassified		21. No. of Pages  27 + appendices	22. Price

## SI\* (MODERN METRIC) CONVERSION FACTORS

### APPROXIMATE CONVERSIONS TO SI UNITS

Symbol	When You Know	Multiply By	To Find	Symbol
<b><u>LENGTH</u></b>				
in	inches	25.4	millimeters	mm
ft	feet	0.305	meters	m
yd	yards	0.914	meters	m
mi	miles	1.61	kilometers	km
<b><u>AREA</u></b>				
in <sup>2</sup>	square inches	645.2	millimeters squared	mm <sup>2</sup>
ft <sup>2</sup>	square feet	0.093	meters squared	m <sup>2</sup>
yd <sup>2</sup>	square yards	0.836	meters squared	m <sup>2</sup>
ac	acres	0.405	hectares	ha
mi <sup>2</sup>	square miles	2.59	kilometers squared	km <sup>2</sup>
<b><u>VOLUME</u></b>				
fl oz	fluid ounces	29.57	milliliters	mL
gal	gallons	3.785	liters	L
ft <sup>3</sup>	cubic feet	0.028	meters cubed	m <sup>3</sup>
yd <sup>3</sup>	cubic yards	0.765	meters cubed	m <sup>3</sup>
NOTE: Volumes greater than 1000 L shall be shown in m <sup>3</sup> .				
<b><u>MASS</u></b>				
oz	ounces	28.35	grams	g
lb	pounds	0.454	kilograms	kg
T	short tons (2000 lb)	0.907	megagrams	Mg
<b><u>TEMPERATURE (exact)</u></b>				
°F	Fahrenheit temperature	5(F-32)/9	Celsius temperature	°C

### APPROXIMATE CONVERSIONS FROM SI UNITS

Symbol	When You Know	Multiply By	To Find	Symbol
<b><u>LENGTH</u></b>				
mm	millimeters	0.039	inches	in
m	meters	3.28	feet	ft
m	meters	1.09	yards	yd
km	kilometers	0.621	miles	mi
<b><u>AREA</u></b>				
mm <sup>2</sup>	millimeters squared	0.0016	square inches	in <sup>2</sup>
m <sup>2</sup>	meters squared	10.764	square feet	ft <sup>2</sup>
ha	hectares	2.47	acres	ac
km <sup>2</sup>	kilometers squared	0.386	square miles	mi <sup>2</sup>
<b><u>VOLUME</u></b>				
mL	milliliters	0.034	fluid ounces	fl oz
L	liters	0.264	gallons	gal
m <sup>3</sup>	meters cubed	35.315	cubic feet	ft <sup>3</sup>
m <sup>3</sup>	meters cubed	1.308	cubic yards	yd <sup>3</sup>
<b><u>MASS</u></b>				
g	grams	0.035	ounces	oz
kg	kilograms	2.205	pounds	lb
Mg	megagrams	1.102	short tons (2000 lb)	T
<b><u>TEMPERATURE (exact)</u></b>				
°C	Celsius temperature	1.8C + 32	Fahrenheit	°F

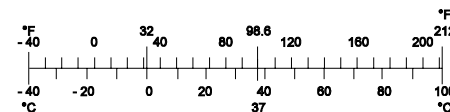

\* SI is the symbol for the International System of Measurement

## **ACKNOWLEDGEMENTS**

The following people served on the Technical Advisory Committee for this project: Mike Harris, Larry Christianson, and Alan Kirk from ODOT; and Victoria Kinne and Jeff Graham from FHWA. Discussion and analysis of the findings were also handled by the ODOT Tall Barrier Design Team: Dan MacDonald, Mike Harris, Terry Wheeler, Sam Grossberg, John Lucas, and Derryl James. For help and guidance in contracting, much appreciation goes to Dan Butcher, Contract Coordinator, ODOT Purchasing and Contract Management Section. Thanks also to Dick Powers and Charles McDevitt at FHWA for their guidance in this project.

## **DISCLAIMER**

This document is disseminated under the sponsorship of the Oregon Department of Transportation and the U.S. Department of Transportation in the interest of information exchange. The State of Oregon and the U.S. Government assumes no liability of its contents or use thereof.

The contents of this report reflect the views of the author(s) who are solely responsible for the facts and accuracy of the material presented. The contents do not necessarily reflect the official views of the Oregon Department of Transportation or the U.S. Department of Transportation.

The State of Oregon and the U.S. Government do not endorse products or manufacturers. Trademarks or manufacturer's names appear herein only because they are considered essential to the object of this document.

This report does not constitute a standard, specification, or regulation.





# PRECAST CONCRETE BARRIER CRASH TESTING

## TABLE OF CONTENTS

<b>1.0 INTRODUCTION.....</b>	<b>1</b>
1.1 BACKGROUND .....	1
1.2 OBJECTIVES OF THE STUDY .....	2
<b>2.0 RESEARCH METHODS.....</b>	<b>3</b>
2.1 CRASH TESTING CRITERIA .....	3
2.2 CRASH TESTS .....	4
2.3 SELECTION OF CRASH TESTING FACILITIES .....	5
<b>3.0 RESULTS AND DISCUSSION .....</b>	<b>7</b>
3.1 CRASH TEST 1 - STANDARD F-SHAPE BARRIER.....	7
3.2 CRASH TEST 2 - TALL F-SHAPE BARRIER.....	9
3.3 CRASH TEST 3 - SECOND TEST OF THE TALL F-SHAPE BARRIER .....	11
<b>4.0 DISCUSSION AND CONCLUSIONS .....</b>	<b>15</b>
4.1 NCHRP REQUIREMENTS .....	15
4.2 DESIGN CONSIDERATIONS .....	15
4.3 CONCLUSION.....	16
<b>5.0 REFERENCES.....</b>	<b>17</b>

## APPENDICES

**APPENDIX A: DESIGN SPECIFICATIONS FOR THE STANDARD F-SHAPE PRECAST CONCRETE BARRIER**

**APPENDIX B: DESIGN SPECIFICATIONS FOR THE TALL F-SHAPE PRECAST CONCRETE BARRIER**

**APPENDIX C: KARCO ENGINEERING TEST LEVEL 3 CRASH TEST REPORT FOR STANDARD F-SHAPE CONCRETE BARRIER (EXCERPT)**

**APPENDIX D: KARCO ENGINEERING TEST LEVEL 3 CRASH TEST REPORT FOR TALL F-SHAPE CONCRETE BARRIER (EXCERPT)**

**APPENDIX E: KARCO ENGINEERING TEST LEVEL 4 CRASH TEST REPORT FOR TALL F-SHAPE CONCRETE BARRIER (EXCERPT)**

## LIST OF TABLES

<b>Table 3.1: Crash Test 1 results - Standard F-shape barrier and 2,000 kg truck .....</b>	<b>8</b>
<b>Table 3.2: Crash Test 2 results - Tall F-shape barrier and 2,000 kg truck.....</b>	<b>10</b>
<b>Table 3.3: Crash Test 3 results - Tall F-shape barrier and 8,000 kg truck.....</b>	<b>12</b>

## LIST OF FIGURES

Figure 1.1: Standard F-shape precast concrete barrier.....	1
Figure 1.2: Tall F-shape precast concrete barrier .....	2
Figure 3.1: Test vehicle prior to Crash Test 1, showing angle of impact .....	7
Figure 3.2: Standard F-shape barrier following Crash Test 1.....	8
Figure 3.3: Test vehicle prior to Crash Test 2, showing angle of impact .....	9
Figure 3.4: Tall F-shape barrier following Crash Test 2.....	10
Figure 3.5: Test vehicle prior to Crash Test 3, showing angle of impact .....	11
Figure 3.6: Tall F-shape barrier following Crash Test 3.....	12

# 1.0 INTRODUCTION

## 1.1 BACKGROUND

The National Cooperative Highway Research Program (NCHRP) has established a comprehensive set of standards and procedures for evaluating the performance of permanent and temporary highway safety features in Report 350, “Recommended Procedures for the Safety Performance Evaluation of Highway Features” (Ross, *et al.* 1993). The Federal Highway Administration (FHWA) has required that by no later than October 2002, states must confirm that their safety features are acceptable under these new standards.

The Oregon Department of Transportation (ODOT) has been using a “Standard F-shape” precast concrete barrier – 810 mm (32 in) in height – along its highways for many years. Approximately 322 km (200 mi) of the current design of barrier are in use. Each barrier section is 3.81 m (12.5 ft) in length. The barrier sections are held together with a pin and steel bar loop assembly. Figure 1.1 shows the Standard F-shape barrier. The specifications for this barrier are included in Appendix A.



Figure 1.1: Standard F-shape precast concrete barrier

In addition, ODOT recently adopted a “Tall F-shape” precast concrete barrier for use on highways which carry large volumes of trucks. The higher barrier – 1065 mm (42 in) in height – is intended to provide more safety on the roadway, by better managing the impact of larger vehicles than the smaller barrier. Each barrier section is 3.0 m (10 ft) in length. The barrier sections are held together with a 25 x 760 mm (1 x 30 in) bolt and perforated C-shape assembly. Figure 1.2 shows the Tall F-shape barrier. The specifications for this barrier are included in Appendix B.



Figure 1.2: Tall F-shape precast concrete barrier

The shape of the concrete barrier was not in question. Both the Standard F-shape and Tall F-shape barriers were acceptable systems under NCHRP Report 350 when cast-in-place (permanent installation). In Oregon, however, the contractor is permitted to select either cast-in-place or precast sections. The trend has been for contractors to choose the less expensive precast option. Thus crash testing of both the Standard F-shape and Tall F-shape precast barrier systems was necessary under FHWA requirements to determine whether they would meet the NCHRP Report 350 standards.

## **1.2 OBJECTIVES OF THE STUDY**

The objectives of this project were to crash test the Oregon Standard F-shape precast concrete barrier and the Oregon Tall F-shape precast concrete barrier against the new NCHRP Report 350 standards, to ensure compliance of these safety systems.

## 2.0 RESEARCH METHODS

### 2.1 CRASH TESTING CRITERIA

NCHRP Report 350 provides a variety of standard crash testing procedures for concrete barriers and criteria for evaluating the results of the tests (*Ross, et al. 1993*). FHWA specified that a Test Level 3 crash test – Test Designation 3-11 – must be performed on both the Standard F-shape and the Tall F-shape barriers. This test calls for crashing a 2,000 kg (4,400 lb) pickup truck into the barrier at 100 km/hr (62 mph), at an angle of 25 degrees from parallel. A total length of 61 m (200 ft) of barrier is required for the test, with the vehicle impact occurring approximately at the middle of the run. The evaluation criteria for this test are as follows (*Ross, et al. 1993*):

- “A. Test article should contain and redirect the vehicle; the vehicle should not penetrate, underide or override the installation, although controlled lateral deflection of the test article is acceptable.
- D. Detached elements, fragments or other debris from the test article should not penetrate or show potential for penetrating the occupant compartment, or present an undue hazard to other traffic, pedestrians or personnel in a work zone. Deformations of, or intrusions into, the occupant compartment that could cause serious injuries should not be permitted.
- F. The vehicle should remain upright during and after collision, although moderate roll, pitching and yawing are acceptable.
- K. After collision it is preferable that the vehicle’s trajectory not intrude into adjacent traffic lanes.
- L. The occupant impact velocity in the longitudinal direction should not exceed 12 m/sec, and the occupant ridedown acceleration in the longitudinal direction should not exceed 20 Gs.
- M. The exit angle from the test article preferably should be less than 60 percent of the test impact angle, measured at time of vehicle loss of contact with test device.”

In addition to these criteria, ODOT has established its own requirement concerning deflection of the barrier from an impact by a vehicle. ODOT specifies that the barrier does not need to be anchored to the roadway if there is at least 914 mm (36 in) of flat area behind the barrier for deflection, with 600 mm (24 in) of this area paved. If there is not the required space behind the barrier for deflection, ODOT requires the system to be anchored to the roadway. Each barrier section has openings to accommodate two 25 x 760 mm (1 x 30 in) galvanized pins for anchoring the section to roadway. These pins are placed 405 mm (15.9 in) from each end of the section and angled at 54 degrees from the horizontal through the base of the barrier.

Thus ODOT was interested to know how each type of barrier performed in terms of deflection as well as in terms of the NCHRP criteria. If either the Standard or the Tall barrier were deflected more than 914 mm (36 in), then anchoring it to the roadway would have to be considered in locations where it was not currently required.

## 2.2 CRASH TESTS

The crash tests were planned as follows:

### Crash Test 1. Crash test of the Standard F-shape barrier, not anchored to the roadway

If the barrier does not pass the crash test, the principal investigator will analyze the results with the testing facility to determine the nature of the failure.

1. If the pin and loop connection between barrier sections contributed to the failure, the connection will be modified to strengthen it, and another test will be conducted.
2. If deflection of the barrier contributed to the failure, or if the barrier was deflected more than 914 mm (36 in), another test will be conducted with the sections anchored to the roadway.

### Crash Test 2. Crash test of the Tall F-shape barrier, not anchored to the roadway

If the barrier fails to meet NCHRP Report 350 standards, a redesign of the barrier may be considered.

Once the results of these crash tests were received and reviewed by the Technical Advisory Committee for the project, one additional crash test – Crash Test 3 – was planned for the Tall F-shape barrier. This was a Test Level 4 crash test – Test Designation 4-12. This test calls for crashing an 8,000 kg (17,637 lb) single-unit truck into the barrier at 80 km/hr (50 mph), at an angle of 15 degrees from parallel. The evaluation criteria for this test are as follows (*Ross, et al. 1993*):

- “A. Test article should contain and redirect the vehicle; the vehicle should not penetrate, underide or override the installation, although controlled lateral deflection of the test article is acceptable.
- D. Detached elements, fragments or other debris from the test article should not penetrate or show potential for penetrating the occupant compartment, or present an undue hazard to other traffic, pedestrians or personnel in a work zone. Deformations of, or intrusions into, the occupant compartment that could cause serious injuries should not be permitted.
- G. It is preferable, although not essential, that the vehicle remain upright during and after collision.
- K. After collision, it is preferable that the vehicle’s trajectory not intrude into adjacent traffic lanes.

- M. The exit angle from the test article preferably should be less than 60 percent of the test impact angle, measured at time of vehicle loss of contact with test device.”

### **2.3 SELECTION OF CRASH TESTING FACILITIES**

Seven crash testing facilities were invited to bid on the project. Three firms submitted bids, and KARCO Engineering in Adelanto, California was selected to conduct the crash testing.





## 3.0 RESULTS AND DISCUSSION

### 3.1 CRASH TEST 1 - STANDARD F-SHAPE BARRIER

On April 17, 2001 Crash Test 1 was conducted. The test article was the Standard F-shape precast concrete barrier with pin and loop connections. Sixteen barrier segments, totaling 61 m (200 ft) were placed in a line and connected together. The line of barriers was placed at an angle of 25 degrees from parallel. The string of barriers was placed directly onto the surface of asphalt concrete with no extra anchoring used. This setup represents the typical method ODOT employs with barrier installation.

The Principal Investigator inspected the layout of the barrier and determined that it was set up correctly. There was a sizable earthen terrace, about 2 m (6 ft) tall, that encircled the test facility. This terrace happened to pass within 4 m (12 ft) of the downstream end of the barrier, thereby causing a potential bottleneck for the test vehicle to impact after it passed the end of the barrier run. It was decided that the terrace was situated well enough beyond the test area that any impact with the terrace would not be likely to affect the outcome of the test. Permission was granted to proceed with the test.

The test vehicle provided by KARCO Engineering was a 1995 Chevrolet Cheyenne  $\frac{3}{4}$  ton pickup (Figure 3.1) with a gross static weight of 2,041 kg (4,500 lb). This weight was within the allowable range of  $\pm 45$  kg, as specified in NCHRP Report 350 (Ross, *et al.* 1993). The pickup was connected by nylon line to a tow cable, which was embedded in a track. The pickup was towed toward the barrier by a tow vehicle. At the point of impact the test vehicle had achieved a speed of 100.74 km/h (62.6 mph).



Figure 3.1: Test vehicle prior to Crash Test 1, showing angle of impact

The point of impact occurred on barrier segment #8, approximately 800 mm (2.6 ft) downstream from the joint between segments #7 and #8. As shown in Figure 3.2, the barrier segments were deflected from the impact; the maximum deflection was 760 mm (30 inches), with no perceptible rebound. The Principal Investigator noted after the impact that there were some minor hairline cracks visible on the backside of the barrier segment #8, which received the initial impact. None of the connection pins failed or were bent. No barrier segment tipped. The test results, as provided by KARCO Engineering, are included in Appendix C and summarized in Table 3.1. As shown in the table, the Standard F-shape barrier passed all of the NCHRP requirements. The terrace was judged not to have had a material effect on the outcome of the test. Thus the crash test of the Standard F-shape barrier was judged to be successful.



Figure 3.2: Standard F-shape barrier following Crash Test 1

**Table 3.1: Crash Test 1 results - Standard F-shape barrier and 2,000 kg truck**

<b>Parameter</b>	<b>Result</b>	<b>NCHRP Requirement</b>
Vehicle containment & redirection	Pass	Vehicle redirection in a controlled manner; no underride or override allowed.
Debris from the impact	Pass	No debris from the impact should present a hazard to occupant compartment or others.
Occupant compartment	Pass	No hazardous deformation or intrusion of the occupant compartment
Vehicle attitude	Pass	Vehicle should remain upright; moderate roll, pitch and yaw acceptable
Occupant impact velocity longitudinal direction	X: -5.85 m/sec Y: 0.0 m/sec	Allowable, not to exceed 12 m/sec
Occupant ridedown acceleration longitudinal direction	X: -12.52 G Y: -18.23 G	Allowable, not to exceed 20 G
Vehicle exit trajectory	11 degrees	Preferred not to exceed 60% x 25 = 15 degrees
Maximum barrier deflection	760 mm (30 inches)	No NCHRP requirement; ODOT requirement: 914 mm (36 in)

### 3.2 CRASH TEST 2 - TALL F-SHAPE BARRIER

On June 19, 2001 Crash Test 2 was conducted. The test article was the Tall F-shape precast concrete barrier with bolted “C-shape” connection. Twenty barrier segments, totaling 61 m (200 ft) were placed in a line and connected together. Again, the line of barriers was placed at an angle of 25 degrees from parallel. The string of barriers was placed directly onto the surface of asphalt concrete with no extra anchoring used. As indicated above, this setup represents the typical method ODOT employs with barrier installation.

The Principal Investigator inspected the layout of the barrier and determined that it was set up correctly. Permission was granted to proceed with the test.

The test vehicle was a 1995 Chevrolet Cheyenne ¾ ton pickup (Figure 3.3) with a gross static weight of 2,024 kg (4,462 lb). This weight was within the allowable range of  $\pm 45$  kg, as specified in NCHRP Report 350 (Ross, *et al.* 1993). The pickup was connected by nylon line to a tow cable, which was embedded in a track. The pickup was towed toward the barrier by a tow vehicle. At the point of impact the test vehicle had achieved a speed of 102.38 km/h (63.6 mph). This velocity was within the allowable range of  $\pm 4$  km/h, as specified in NCHRP Report 350 (Ross, *et al.* 1993).



Figure 3.3: Test vehicle prior to Crash Test 2, showing angle of impact

The point of impact occurred on barrier segment #10, approximately 150 mm (6 in) upstream of the joint between segments #10 and #11. As shown in Figure 3.4, the barrier segments were deflected from the impact; the maximum deflection was 813 mm (32 inches), with no perceptible rebound.



Figure 3.4: Tall F-shape barrier following Crash Test 2

The test results, as provided by KARCO Engineering, are included in Appendix D and summarized in Table 3.2. As shown in the table, the Tall F-shape barrier passed all of the NCHRP requirements. Again, the terrace was judged not to have had a material effect on the outcome of the test. Thus the crash test of the Tall F-shape barrier was judged to be successful.

The Principal Investigator noted some minor spalling of concrete at the joint where impact occurred. None of the connecting bolts failed or was bent. The Principal Investigator requested that KARCO make special note in the report of the disassembly of the system, with regard to potential difficulties of bent bolts and their removal. KARCO personnel reported that they had no major problems taking the system apart, only the need to realign some of the segments so that the bolts could be turned easier.

**Table 3.2: Crash Test 2 results - Tall F-shape barrier and 2,000 kg truck**

Parameter	Result	NCHRP Requirement
Vehicle containment & redirection	Pass	Vehicle redirection in a controlled manner; no underride or override allowed.
Debris from the impact	Pass	No debris from the impact should present a hazard to occupant compartment or others.
Occupant compartment	Pass	No hazardous deformation or intrusion of the occupant compartment
Vehicle attitude	Pass	Vehicle should remain upright; moderate roll, pitch and yaw acceptable
Occupant impact velocity longitudinal direction	X: -6.22 m/sec Y: 5.08 m/sec	Allowable, not to exceed 12 m/sec
Occupant ridedown acceleration longitudinal direction	X: -19.36 G Y: 12.25 G	Allowable, not to exceed 20 G
Vehicle exit trajectory	12 degrees	Preferred not to exceed $60\% \times 25 = 15$ degrees
Maximum barrier deflection	813 mm (32 inches)	No NCHRP requirement; ODOT requirement: 914 mm (36 in)

### 3.3 CRASH TEST 3 - SECOND TEST OF THE TALL F-SHAPE BARRIER

The ODOT Research work plan and contract had provided for the possibility of a crash test failure, necessitating at least one subsequent test. Since the first two tests were successful, it was decided by the Technical Advisory Committee to subject the Tall F-shape barrier to a test involving a larger vehicle, since its intended use was on highways which carried large volumes of trucks. NCHRP Report 350 defines parameters for such a test, Test Level 4 (Test Designation 4-12), which utilizes a single-unit truck weighing 8,000 kg (17,637 lb). This test calls for crashing the truck into the barrier at a speed of 80 km/h (50 mph) and at an impact angle of 15 degrees. The Test Level 4 impact is calculated to be slightly lower in expended energy than the Test Level 3, but with the higher center of gravity of the test vehicle, a critical concern is a greater tendency for the truck to tip over the barrier.

Crash Test 3 was conducted on September 18, 2001. The test article was the Tall F-shape precast concrete barrier, as used in Test 2. The barrier sections were assembled to ensure that the segments in the impact area were in like-new condition and had not been affected by the earlier test.

The test vehicle provided by KARCO Engineering was a 1995 Ford F 600 box truck (Figure 3.5) with a curb weight of 4,312 kg (9,506 lb), with added ballast bringing it to a gross static weight of 7,917 kg (17,454 lb). This weight was within the allowable range of  $\pm 200$  kg, as specified in NCHRP Report 350 (Ross, *et al.* 1993). The truck was connected by nylon line to a tow cable, which was embedded in a track. The truck was towed toward the barrier, and at the point of impact it had achieved a speed of 76.06 km/h (47.3 mph). This velocity was within the allowable range of  $\pm 5$  km/h, as specified in NCHRP Report 350 (Ross, *et al.* 1993).



Figure 3.5: Test vehicle prior to Crash Test 3, showing angle of impact

The point of impact occurred on barrier segment #8, approximately 800 mm (2.6 ft) upstream of the joint between segments #8 and #9. As shown in Figure 3.6, the barrier segments were deflected from the impact; the maximum deflection was 826 mm (32.5 inches), with no perceptible rebound.



Figure 3.6: Tall F-shape barrier following Crash Test 3

The test results, as provided by KARCO Engineering are included in Appendix E and summarized in Table 3.3. As shown in the table, the Tall F-shape barrier passed all of the NCHRP requirements. Thus the Test Level 4 crash test of the Tall F-shape barrier was judged to be successful.

**Table 3.3: Crash Test 3 results - Tall F-shape barrier and 8,000 kg truck**

<b>Parameter</b>	<b>Result</b>	<b>NCHRP Requirement</b>
Vehicle containment & redirection	Pass	Vehicle redirection in a controlled manner; no underride or override allowed.
Debris from the impact	Pass	No debris from the impact should present a hazard to occupant compartment or others.
Occupant compartment	Pass	No hazardous deformation or intrusion of the occupant compartment
Vehicle attitude	Pass	Preferable that the vehicle remain upright
Occupant impact velocity longitudinal direction	X: 1.87 m/sec Y: 2.74 m/sec	No NCHRP requirement
Occupant ridedown acceleration longitudinal direction	X: -5.29 G Y: -6.78 G	No NCHRP requirement
Vehicle exit trajectory	7.3 degrees	Preferred not to exceed 60% x 15 = 9 degrees
Maximum barrier deflection	826 mm (32.5 in)	No NCHRP requirement; ODOT requirement: 914 mm (36 in)

Unforeseen circumstances prevented the Principal Investigator from attending this test. The test facility personnel were asked to inspect the barrier for damage following the test; there was no mention of undue damage to the barrier. The barrier was disassembled with no broken or bent bolts encountered.

KARCO Engineering disclosed after the test that they had remotely applied the brakes to the truck after the impact, while the truck's wheels were not in contact with the ground. They explained that they were concerned that the momentum of the test vehicle would carry it into the video recording equipment set up for the test. Applying the brakes to a test vehicle is not normal procedure. In addition to the application of the brakes, the video recording showed that both front wheels turned sharply to the right when the truck came back in contact with the ground, thus causing a plowing effect in the dirt. Thus both the plowing of the front wheels and the remote braking had an effect on the stopping behavior of the vehicle. While the vehicle probably did come to a halt sooner due to the remote braking, this was not judged to have significantly affected the test outcome.





## **4.0 DISCUSSION AND CONCLUSIONS**

### **4.1 NCHRP REQUIREMENTS**

The principal objective of this research was to determine whether Oregon's Standard F-shape and Tall F-shape precast concrete barriers could meet the requirements of NCHRP Report 350. FHWA has specified that these safety devices meet the NCHRP Test Level 3 requirements.

Printed reports and videotapes of the first two crash tests were sent to FHWA for review and approval. FHWA initially noted that KARCO Engineering's report on the first crash test did not contain some documentation as required by NCHRP Report 350. KARCO Engineering subsequently submitted an amended report to the satisfaction of FHWA.

In its letter of acceptance, FHWA both acknowledged that the barriers had met the NCHRP requirements and also praised their performance:

“Based on the reported results of the tests run on these barriers, both the 810-mm tall and the 1065-mm tall designs are considered to meet the evaluation criteria of the National Cooperative Highway Research Program (NCHRP) Report 350 at test level 3 (TL-3) and may be used on the National Highway System when such use is acceptable to the contracting authority. Both barriers exhibited the least amount of deflection and resulted in the most stable, post-impact vehicle trajectories of any free-standing, precast barrier tested to date.” (*Wright 2001*)

This recognition from FHWA has generated calls from ten states, expressing an interest in ODOT's barrier design.

### **4.2 DESIGN CONSIDERATIONS**

Given that the Tall F-shape barrier deflected slightly more than the Standard F-shape barrier in Test Level 3, the ODOT design team identified two issues it wished to address:

- Although the Tall Barrier is more massive, why didn't it perform better than the Standard Barrier?
- What could ODOT do to improve the Tall Barrier to make it outperform the Standard Barrier?

Upon further analysis of the test results and video recordings, ODOT speculated that the Tall Barrier deflected more than the Standard Barrier probably because a) the impact on the Tall Barrier was so close to the joint; and b) the length of the Tall Barrier segments is 810 mm (30 in) shorter than that of the Standard Barrier segments, making the system more flexible.

If the barrier segments were lengthened to the same dimension as the standard barrier – i.e. 3.81 m (12.5 ft), it would decrease the flexibility of the system. In addition, each segment would then weigh approximately 3,630 kg (8,000 lb), increasing the resistance to movement on the road surface. This design change could be undertaken without further testing, since FHWA considers lengthening of the barrier to be an improvement.

Another beneficial change to the design would be the addition of pinning holes, to be used if there were not adequate room for deflection. These design changes have been made, and ODOT has concluded that the Tall F-shape barrier would likely outperform the Standard F-shape barrier in identical tests.

The Test Level 4 results for the Tall Barrier provides useful information on the performance of this type of system. A permanent installation of this type of barrier has been shown to contain and redirect tractor-trailer trucks (*McDevitt 2000*). The ODOT crash test, however, employed temporary precast barrier sections, with no anchoring to the roadway. The barrier as tested was deflected less than a meter from the impact of the 8,000 kg truck, and the truck remained upright and safely redirected. FHWA has reviewed the test results and the video documentation and has issued a letter acknowledging the effectiveness of the Tall F-shape barrier under Test Level 4 conditions:

“Based on the reported results of the test, the 1065-mm tall design satisfies the evaluation criteria of the National Cooperative Highway Research Program (NCHRP) Report 350 for a test level 4 (TL-4) longitudinal barrier and may be used on the National Highway System when such use is acceptable to the contracting authority.” (*Halladay 2001*)

### **4.3 CONCLUSION**

Both the currently used Standard F-shape precast concrete barrier and the newly adopted Tall F-shape precast concrete barrier fully satisfy the requirements of NCHRP Report 350. Indeed, FHWA has acknowledged both barriers as having the best performance of any free-standing precast concrete barrier to date. Furthermore, the performance of the Tall F-shape barrier with larger trucks, enhanced by the design changes described above, promises to make it very valuable as a new safety feature on Oregon’s highways.

## 5.0 REFERENCES

Halladay, Michael. Personal correspondence. Federal Highway Administration. HSA-10/B-86a. November 21, 2001.

McDevitt, Charles F. "Basics of Concrete Barriers," *Public Roads*. Turner-Fairbank Highway Research Center, Federal Highway Administration, McLean, VA. Vol. 63, No. 5. 2000.

Ross, H.E. Jr., D.L. Sicking, R.A. Zimmer and J.D. Michie. National Cooperative Highway Research Program Report 350: *Recommended Procedure for the Safety Performance Evaluation of Highway Features*. Transportation Research Board. National Academy Press, Washington, DC. 1993.

Wright, Frederick G. Personal correspondence. Federal Highway Administration. HSA-10/B-86. August 17, 2001.



## **APPENDICES**



**APPENDIX A:**

**DESIGN SPECIFICATIONS  
FOR THE  
STANDARD F-SHAPE PRECAST CONCRETE BARRIER**









**APPENDIX B**

**DESIGN SPECIFICATIONS**  
**FOR THE**  
**TALL F-SHAPE PRECAST CONCRETE BARRIER**



**GENERAL NOTES**

- All reinforcing steel shall conform to ASTM A706M or AASHTO M31M (ASTM A615M) Grade 420. All bars shall be full length as shown and shall be placed 50 mm clear of the nearest face of concrete unless shown otherwise.
- All structural steel including fasteners shall be hot-dip galvanized after fabrication.
- Normal use of precast single slope median barrier is restricted to curves with radii greater than 250 m.
- Chamfer all edges 20 mm (typical).
- Perforated C-shape shall be placed in location shown to a tolerance of 2 mm.
- Estimated barrier weight is 2880 kg per 3 m unit length. Estimated vertical backed barrier weight is 2340 kg.

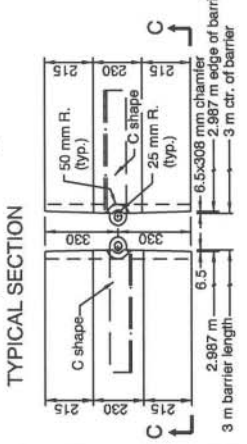
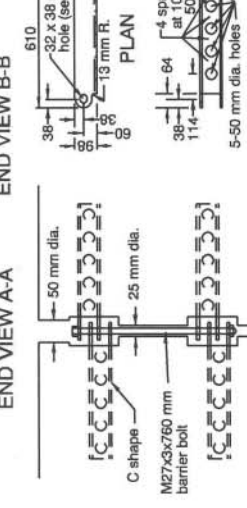
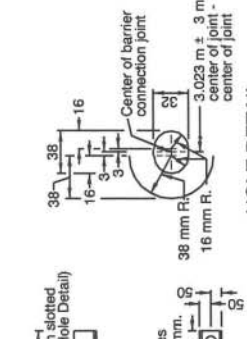
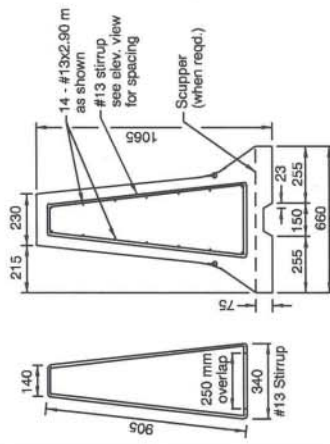
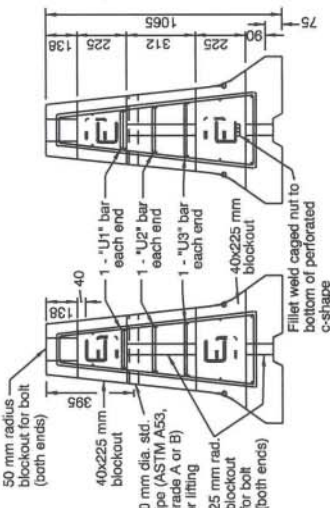
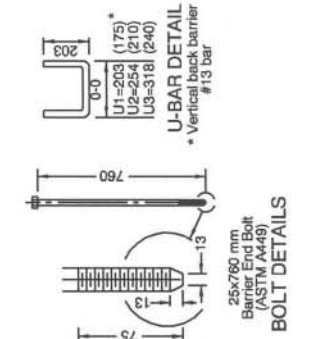

• All dimensions are in mm unless otherwise noted.

NOTE: All material and workmanship shall be in accordance with the current Oregon Standard Specifications

**OREGON STANDARD DRAWINGS**

DATE	REVISED	DESCRIPTION

**REGISTERED PROFESSIONAL ENGINEER**  
14,037

**OREGON**  
JULY 28, 1988  
DANIEL J. WOODWARD  
EXPIRES 12-31-2002



**APPENDIX C**

**KARCO ENGINEERING  
TEST LEVEL 3 CRASH TEST REPORT FOR  
STANDARD F-SHAPE CONCRETE BARRIER  
(EXCERPT)**





## SECTION 1 INTRODUCTION

### 1.1 OBJECTIVES

The objective of this crash test was to determine if the tested free-standing, unanchored, concrete median barrier (CMB) system meets the minimum performance standards of the National Cooperative Highway Research Program Report 350 (NCHRP 350) test level 3 guidelines. This report presents the results of the performance and evaluation of a full-scale crash test conducted on a series of sixteen (16) concrete redirective longitudinal barriers. The redirective longitudinal barriers are similar to those currently used on highways and have similar mass centers of gravity.

All tests were conducted in accordance with current NCHRP 350 requirements. Procedures for receiving, inspecting, testing and reporting of test results are described in the test procedure and are not repeated in this report. The purpose of this test was to evaluate strength of the section containing and redirecting the 2000P test vehicle. The longitudinal redirective barriers are composed of steel-reinforced concrete. The longitudinal barriers are designed to deflect the 2000P vehicle while remaining linked to one another in series, thereby minimizing excessive snagging or pocketing and safely containing and redirecting the 2000P vehicle.

### 1.2 TEST FACILITY

All tests were conducted at KARCO Engineering's crash test facility in Adelanto, California. The tow road is constructed of reinforced concrete, presents a continuous level surface, and measures 850 in length. The width of the tow road is twelve feet ten inches (12 ft 10 in.) with a thickness of six inches (6 in.). A steel rail is embedded in the approach surface to provide vehicle guidance. Vehicle tow propulsion is provided by a  $\frac{3}{4}$  ton truck using a 2 to 1 pulley system coupled to a fixed prime mover (an internal combustion engine, Chevrolet V-8, 454 cubic inches displacement, with T-400 automatic transmission) and continuous cable drive system. The test vehicle is towed to within two feet of the test article by a nylon rope clamped to a  $\frac{3}{8}$  inch steel cable. The clamp is released from the cable on contact with a cable release mechanism positioned to allow the test vehicle to proceed under its own momentum for the final two feet of travel before impacting the test series.

### 1.3 TEST ARTICLE

The tested devices consist of a series of sixteen (16) concrete redirective longitudinal barriers constructed to the dimensions of 3.84 meters (m) (151.2 inches) in length and 0.81 meters (m) (31.9 inches) in height.

SECTION 3  
TEST RESULTS AND DATA SHEETS

3.1 TEST NO. 3-11

This one hundred kilometers per hour (100 km/h) impact crash test was conducted using a 1995 Chevrolet 3/4 ton pickup truck to determine if the tested concrete median barriers (CMB) meet the minimum performance standards of the NCHRP 350 recommendations for test level 3 redirective longitudinal barriers. NCHRP 350 Test 3-11 is intended to evaluate occupant risk and vehicle trajectory evaluation criteria with an angled impact of a type 2000P vehicle impacting at the mid-point of the CMB. This test is also intended to evaluate strength of the section in containing and redirecting the 2000P test vehicle.

The test vehicle was aligned such that the sides of the longitudinal barriers were impacted by the right front bumper of the test vehicle. This crash test was documented by one (1) real-time panning motion picture camera and seven (7) high-speed motion picture cameras. Pre- and post-test photographs of the vehicle and crash cushions can be found in Appendix A (Figures 1 thru 12).

Test 3-11 was conducted on April 17, 2001. The test inertial weight of the vehicle was 2041 kg (4500 lbs.) and its gross static weight was also 2041 kg (4500 lbs.). The height to the lower edge of the front bumper was 451 mm (17.75 in.) and the upper edge was 671 mm (26.42 in.). Additional dimensions and vehicle information are presented in Data Sheet No. 1.

The test vehicle impacted the eighth rail in the concrete rail series at a velocity of 100.7 km/h (62.6 mph). The vehicle remained in physical contact with the longitudinal barrier series for 220 msec. The vehicle rotated on its axis approximately eleven degrees (11°), was re-directed to the left of the barriers and came to rest approximately 1.5 meters to the left of the end of the series of barriers due to an embankment near the end of the series, as shown in Figure 6. Sequential photographs of the test sequence are shown in Appendix D. The windshield remained intact. The vehicle sustained moderate damage to the bumper, grill, hood, passenger side fender, and passenger side wheels as a result of the impact with the redirective longitudinal barriers. The vehicle sustained no vertical or longitudinal deformation to the roof. Maximum vehicle crush at the bumper height was indeterminate. There was no deformation or intrusion into the vehicle occupant compartment.

Ten (10) of the modules were displaced by the impact. The maximum depth of the movement of the longitudinal barriers (barriers 7 through 10) was thirty inches (30 in.) Barriers 1 through 6 were dragged approximately 1.5 inches forward of their original position (parallel to the series of longitudinal barriers). A summary of the electronic data is presented in data Sheet No. 2. Data plots are presented in Appendix B. Table 4 (Section 4) shows the NCHRP Report 350 evaluation criteria and the assessment of the performance of this installation with respect to those criteria.

DATA SHEET NO. 1

VEHICLE PROPERTIES FOR TEST NO. 3-11

DATE	<b>04/11/01</b>	COLOR	<b>WHITE</b>	VIN	<b>1GC6C24K8SE197292</b>
YEAR	<b>1995</b>	MAKE	<b>CHEVROLET</b>	MODEL	<b>CHEYENNE TRUCK</b>
TIRE PRESSURE (psi)	<b>45/80</b>	ODOMETER (mi.)	<b>289043</b>	TIRE SIZE	<b>LT245/75 R16E</b>
ENGINE	<b>FRONT</b>	CYLINDERS	<b>8</b>	DISPLACEMENT	<b>5.7 LITER</b>
TRANSMISSION	<b>4-SPEED</b>	AUTOMATIC	<b>YES</b>	MANUAL	<b>NO</b>
DESCRIBE ANY DAMAGE TO VEHICLE PRIOR TO TEST:			<b>MINOR DAMAGE TO LEFT REAR FENDER UNDER TAIL LIGHT.</b>		

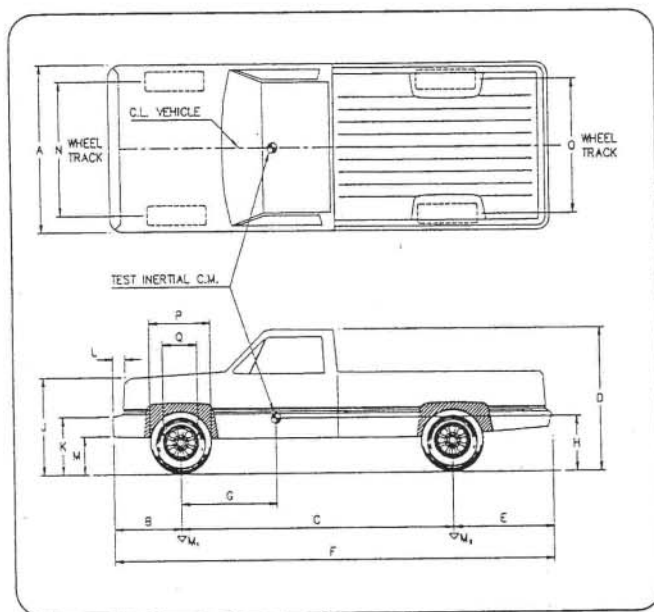

TEST VEHICLE GEOMETRY (mm)							
A	<b>1890</b>	E	<b>1323</b>	J	<b>1032</b>	N	<b>1597</b>
B	<b>914</b>	F	<b>5577</b>	K	<b>671</b>	O	<b>1620</b>
C	<b>3344</b>	G	<b>n/a</b>	L	<b>86</b>	P	<b>775</b>
D	<b>1838</b>	H	<b>n/a</b>	M	<b>451</b>	Q	<b>444</b>

MASS DISTRIBUTION							
LEFT FRONT	<b>604 kg (1332 lb)</b>	RIGHT FRONT	<b>589 kg (1298 lb)</b>	LEFT REAR	<b>493 kg (1086 lb)</b>	RIGHT REAR	<b>480 kg (1058 lb)</b>
MASS (kg)		CURB		TEST INERTIAL		GROSS STATIC	
FRONT AXLE		<b>1193 kg (2630 lb)</b>		<b>1024 kg (2258 lb)</b>		<b>1024 kg (2258 lb)</b>	
REAR AXLE		<b>973 kg (2144 lb)</b>		<b>881 kg (1942 lb)</b>		<b>881 kg (1942 lb)</b>	
TOTAL VEHICLE		<b>2165 kg (4774 lb)</b>		<b>2041 kg (4500 lb)</b>		<b>2041 (4500 lb)</b>	

DATA SHEET NO. 2

SUMMARY OF RESULTS FOR TEST NO. 3-11

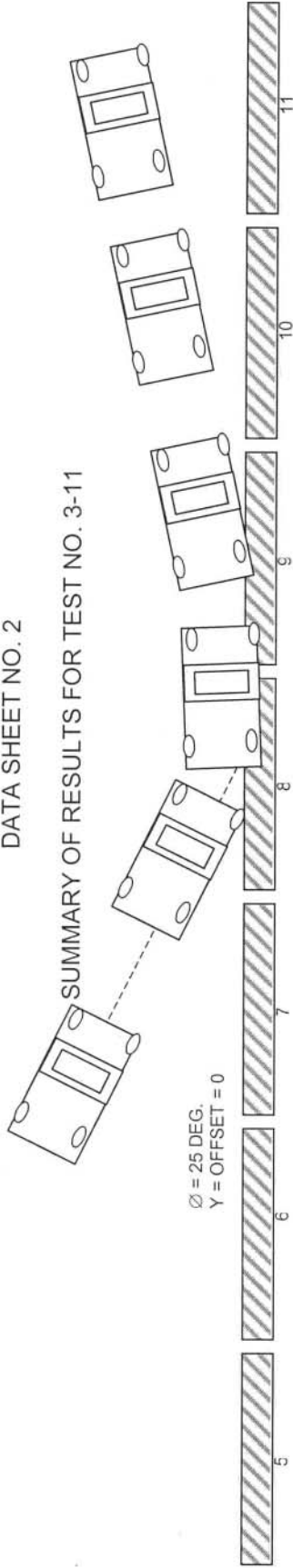

LONGITUDINAL BARRIERS

GENERAL INFORMATION		OCCUPANT RISK VALUES	
TEST AGENCY	KARCO ENGINEERING	IMPACT VELOCITY (m/sec)	-5.85
TEST NO.	3-11	X-DIRECTION	0
DATE	04/17/01	Y-DIRECTION	N/A
TEST ARTICLE		THIV (optional)	N/A
TYPE	LONGITUDINAL BARRIERS	RIDEDOWN ACCELERATION (g's)	
INSTALLATION LENGTH (m)	61.37 m (201.3 ft.) precast concrete	X-DIRECTION	+ 11.17 to -12.52
SIZE AND/OR DIMENSION OF KEY ELEMENTS	3.84 m (12 ft 7 in.)	Y-DIRECTION	+ 15.96 to -18.23
SOIL TYPE AND CONDITION	N/A	PHD (optional)	N/A
TEST VEHICLE		ASI (optional)	1.614
TYPE	PRODUCTION	TEST ARTICLE DEFLECTIONS (m)	
DESIGNATION	2000P	DYNAMIC	30 in.
MODEL	1995 CHEVROLET PICKUP TRUCK	PERMANENT	30 in.
MASS (CURB)	2165 kg	VEHICLE DAMAGE	
MASS (TEST INERTIAL)	2041 kg	EXTERIOR	
DUMMY(S) MASS	N/A	VDS	n/a
GROSS STATIC WEIGHT	2041 kg	GDC	n/a
IMPACT CONDITIONS		INTERIOR	
SPEED (km/h)	100.74 k/h (62.6 mph)	OCDI	n/a
ANGLE (Deg.)	25		
IMPACT SEVERITY (kJ)	N/A		
EXIT CONDITIONS		POST IMPACT VEHICULAR BEHAVIOR	
SPEED (km/h)	81.72	MAXIMUM ROLL ANGLE (Deg.)	+ 14.18 to -14.58
ANGLE (Deg.)	11°	MAXIMUM PITCH ANGLE (Deg.)	+ 0.68 to -20.11
		MAXIMUM YAW ANGLE (Deg.)	+ 0.07 to -33.75

**APPENDIX D**

**KARCO ENGINEERING  
TEST LEVEL 3 CRASH TEST REPORT FOR  
TALL F-SHAPE CONCRETE BARRIER  
(EXCERPT)**



## SECTION 1 INTRODUCTION

### 1.1 OBJECTIVES

The objective of this crash test was to determine if the tested freestanding, unanchored, concrete median barrier (CMB) system meets the minimum performance standards of the National Cooperative Highway Research Program Report 350 (NCHRP 350) test level 3 guidelines. This report presents the results of the performance and evaluation of a full-scale crash test conducted on a series of twenty (20) concrete redirective longitudinal barriers. The redirective longitudinal barriers are similar to those currently used on highways and have similar mass centers of gravity.

All tests were conducted in accordance with current NCHRP 350 requirements. Procedures for receiving, inspecting, testing and reporting of test results are described in the test procedure and are not repeated in this report. The purpose of this test was to evaluate strength of the section containing and redirecting the 2000P test vehicle. The longitudinal redirective barriers are composed of steel-reinforced concrete. The longitudinal barriers are designed to deflect the 2000P vehicle while remaining linked to one another in series, thereby minimizing excessive snagging or pocketing and safely containing and redirecting the 2000P vehicle.

### 1.2 TEST FACILITY

All tests were conducted at KARCO Engineering's crash test facility in Adelanto, California. The tow road is constructed of reinforced concrete, presents a continuous level surface, and measures 850 ft length. The width of the tow road is twelve feet ten inches (12 ft 10 in.) with a thickness of six inches (6 in.). A steel rail is embedded in the approach surface to provide vehicle guidance. Vehicle tow propulsion is provided by a  $\frac{3}{4}$  ton truck using a 2 to 1 pulley system coupled to a fixed prime mover (an internal combustion engine, Chevrolet V-8, 454 cubic inches displacement, with T-400 automatic transmission) and continuous cable drive system. The test vehicle is towed to within two feet of the test article by a nylon rope clamped to a  $\frac{3}{8}$  inch steel cable. The clamp is released from the cable on contact with a cable release mechanism positioned to allow the test vehicle to proceed under its own momentum for the final twenty feet of travel before impacting the test series.

### 1.3 TEST ARTICLE

The tested devices consist of a series of twenty (20) concrete redirective longitudinal barriers. Each test article is a 1065 mm high F-shape with a 660 mm wide base and a 230 mm wide top. Barrier segments are 3.023 m long and are connected with 79 mm thick perforated C-chaps that when meshed with opposing ends forms eight points of connection. Connecting the C-shapes is a 27 x 3 x 760 mm barrier end bolt conforming to ASTM A449. The C-shapes and bolts are hot-dip galvanized after

fabrication. The allowable gap between matched barrier ends is 25mm. Reinforcement consists of seven equally spaced 13 mm longitudinals on each face, tied to end U-bars. The longitudinals are tied to nineteen 13 mm vertical stirrup pairs of varied spacings. A diagram of the Tall F-shape Concrete Median Barrier is presented in Appendix C, Page C-3.



SECTION 3  
TEST RESULTS AND DATA SHEETS

3.1 TEST NO. 3-11

This one hundred kilometers per hour (100 km/h) impact crash test was conducted using a 1995 Chevrolet 3/4 ton pickup truck to determine if the tested concrete median barriers (CMB) meet the minimum performance standards of the NCHRP 350 recommendations for test level 3 redirective longitudinal barriers. NCHRP 350 Test 3-11 is intended to evaluate occupant risk and vehicle trajectory evaluation criteria with an angled impact of a type 2000P vehicle impacting at the mid-point of the CMB. This test is also intended to evaluate strength of the section in containing and redirecting the 2000P test vehicle.

The test vehicle was aligned such that the edges of the longitudinal barriers were impacted by the right front bumper of the test vehicle. This crash test was documented by one (1) real-time panning motion picture camera and seven (7) high-speed motion picture cameras. Pre- and post-test photographs of the vehicle and crash cushions can be found in Appendix A (Figures 1 thru 14).

Test 3-11 was conducted on June 19, 2001. The test inertial weight of the vehicle was 2024 kg (4462 lbs.) and its gross static weight was also 2024 kg (4462 lbs.). The height to the lower edge of the front bumper was 500 mm (19.69 in.) and the upper edge was 650 mm (25.59 in.). Additional dimensions and vehicle information are presented in Data Sheet No. 1.

The test vehicle impacted the tenth rail in the concrete rail series at a velocity of 102.38 km/h (63.62 mph). The vehicle remained in physical contact with the longitudinal barrier series for 276 msec. The vehicle rotated on its axis approximately twelve degrees (12°), was re-directed to the left of the barriers and came to rest approximately 3.0 meters to the left of and 7.3 meters behind the end of the series of barriers due to an embankment near the end of the series, as shown in Figures 2, 4 and 12. Sequential photographs of the test sequence are shown in Appendix D. The vehicle sustained major damage to the passenger side bumper, right front fender and right front wheel as a result of the impact with the redirective longitudinal barriers. The vehicle sustained moderate damage to the grill, hood, and passenger side door. The vehicle received slight damage to the driver side door and driver side front fender, as well as the loss of both front tires, and passenger side turn signal, and passenger side headlights. The windshield suffered slight damage (a crack running from lower right corner to top of windshield on right side), but does not interfere with the driver's vision. The vehicle sustained negligible deformation to the roof. Maximum vehicle crush at the bumper height was indeterminate. Post-test photographs of the test vehicle are presented in Appendix A.

There was no unacceptable deformation or intrusion into the vehicle occupant compartment; the floor pan deformation measurements are shown in Data Sheet No. 3.

Eight (8) of the barriers were displaced by the impact. The maximum depth of the movement of the longitudinal barriers (barriers 5 through 12) was 812.8 mm (32 in.). Barriers 7 and 14 were shifted 50.8 mm (2 in.) opposite the direction of impact, as opposed to barriers 8 through 13, which were moved and angled

in the direction of the impact. A summary of the electronic data is presented in data Sheet No. 2. Data plots are presented in Appendix B. Table 4 (Section 4) shows the NCHRP Report 350 evaluation criteria and the performance assessment of this installation with respect to those criteria.

DATA SHEET NO. 1

VEHICLE PROPERTIES FOR TEST NO. 3-11

DATE	06/18/01	COLOR	WHITE	VIN	1GC6C24K8SE197292
YEAR	1995	MAKE	CHEVROLET	MODEL	CHEYENNE TRUCK
TIRE PRESSURE (psi)	45/80	ODOMETER (mi.)	289044	TIRE SIZE	LT245/75 R16E
ENGINE	FRONT	CYLINDERS	8	DISPLACEMENT	5.7 LITER
TRANSMISSION	4-SPEED	AUTOMATIC	YES	MANUAL	NO
DESCRIBE ANY DAMAGE TO VEHICLE PRIOR TO TEST:			BROKEN REARVIEW MIRROR, DENTS & SCRATCHES IN DOORS, BED IS SHIFTED TO RIGHT FROM PREV. CRASH, MINOR DAMAGE TO LEFT REAR FENDER UNDER TAIL LIGHT.		

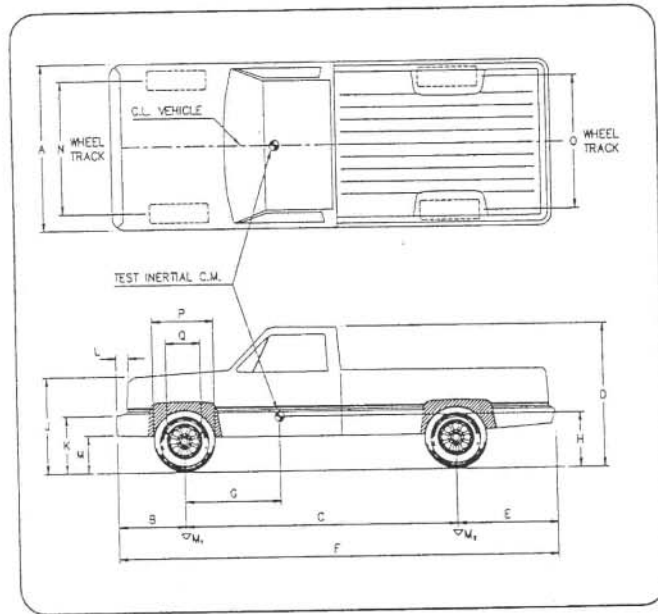

TEST VEHICLE GEOMETRY (mm)							
A	880	E	1330	J	1075	N	620
B	860	F	5518	K	650	O	620
C	3328	G	1963	L	98	P	760
D	1830	H	760	M	500	Q	445

MASS DISTRIBUTION							
LEFT FRONT	539 kg (1188 lb)	RIGHT FRONT	584 kg (1288 lb)	LEFT REAR	480 kg (1058 lb)	RIGHT REAR	421 kg (928 lb)
MASS (kg)		CURB		TEST INERTIAL		GROSS STATIC	
FRONT AXLE		1193 kg (2630 lb)		1123 kg (2476 lb)		1123 kg (2476 lb)	
REAR AXLE		973 kg (2144 lb)		901 kg (1986 lb)		901 kg (1986 lb)	
TOTAL VEHICLE		2165 kg (4774 lb)		2024 (4462 lb)		2024 (4462 lb)	

DATA SHEET NO. 2

SUMMARY OF RESULTS FOR TEST NO. 3-11

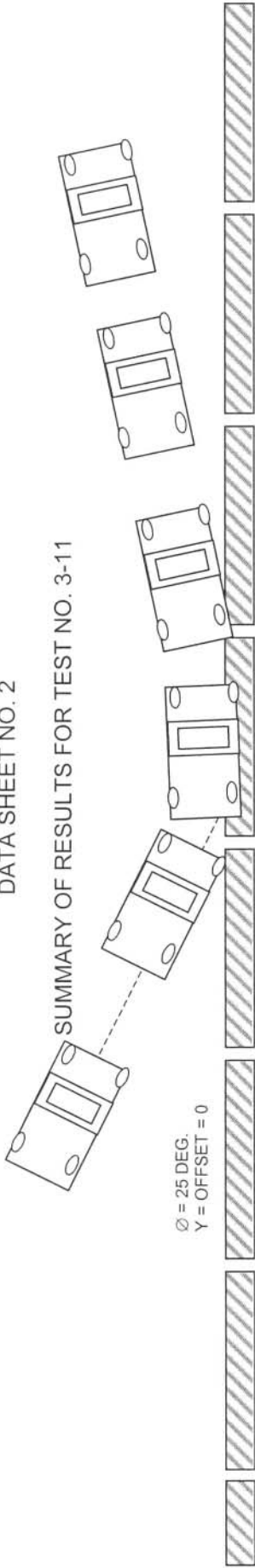

	7	8	9	10	11	12	13	14
<b>GENERAL INFORMATION</b>								
TEST AGENCY	KARCO ENGINEERING							
TEST NO.	3-11							
DATE	06/19/01							
TEST ARTICLE								
TYPE	LONGITUDINAL BARRIERS							
INSTALLATION LENGTH (m)	60.96 m (200 ft.) precast concrete							
SIZE AND/OR DIMENSION OF KEY ELEMENTS	3.023 m (9 ft 11 in.)							
SOIL TYPE AND CONDITION	N/A							
TEST VEHICLE								
TYPE	PRODUCTION							
DESIGNATION	2000P							
MODEL	1995 CHEVROLET PICKUP TRUCK							
MASS (CURB)	2165 kg							
MASS (TEST INERTIAL)	2024 kg							
DUMMY(S) MASS	N/A							
GROSS STATIC WEIGHT	2024 kg							
<b>IMPACT CONDITIONS</b>								
SPEED (km/h)	102.38 km/h (63.62 mph)							
ANGLE (Deg.)	25°							
IMPACT SEVERITY (kJ)	N/A							
<b>EXIT CONDITIONS</b>								
SPEED (km/h)	81.00 km/h (50.34 mph)							
ANGLE (Deg.)	12°							
<b>OCCUPANT RISK VALUES</b>								
IMPACT VELOCITY (m/sec)								
X-DIRECTION	-6.22 m/sec							
Y-DIRECTION	5.08 m/sec							
THIV (optional)	N/A							
<b>RIDEDOWN ACCELERATION (g's)</b>								
X-DIRECTION	+ 10.10 to -19.36							
Y-DIRECTION	+ 12.25 to -8.58							
PHD (optional)	N/A							
ASI (optional)	1.405							
<b>TEST ARTICLE DEFLECTIONS (m)</b>								
DYNAMIC	32 in.							
PERMANENT	32 in.							
<b>VEHICLE DAMAGE</b>								
EXTERIOR	n/a							
VDS	n/a							
CDC	n/a							
INTERIOR	n/a							
OCDI	n/a							
<b>POST IMPACT VEHICULAR BEHAVIOR</b>								
MAXIMUM ROLL ANGLE (Deg.)	+ 16.04 to -11.49							
MAXIMUM PITCH ANGLE (Deg.)	+ 23.07 to -1.12							
MAXIMUM YAW ANGLE (Deg.)	+ 0.41 to -32.54							

**APPENDIX E**

**KARCO ENGINEERING  
TEST LEVEL 4 CRASH TEST REPORT FOR  
TALL F-SHAPE CONCRETE BARRIER  
(EXCERPT)**



## SECTION 1 INTRODUCTION

### 1.1 OBJECTIVES

The objective of this crash test was to determine if the tested freestanding, unanchored, concrete median barrier (CMB) system meets the minimum performance standards of the National Cooperative Highway Research Program Report 350 (NCHRP 350) test level 4 guidelines. This report presents the results of the performance and evaluation of a full-scale crash test conducted on a series of twenty (20) concrete redirective longitudinal barriers. The redirective longitudinal barriers are similar to those currently used on highways and have similar mass centers of gravity.

All tests were conducted in accordance with current NCHRP 350 requirements. Procedures for receiving, inspecting, testing and reporting of test results are described in the test procedure and are not repeated in this report. The purpose of this test was to evaluate strength of the section containing and redirecting the 8000S test vehicle. The longitudinal redirective barriers are composed of steel-reinforced concrete. The longitudinal barriers are designed to deflect the 8000S vehicle while remaining linked to one another in series, thereby minimizing excessive snagging or pocketing and safely containing and redirecting the 8000S vehicle.

### 1.2 TEST FACILITY

All tests were conducted at KARCO Engineering's crash test facility in Adelanto, California. The tow road is constructed of reinforced concrete, presents a continuous level surface, and measures 850 ft length. The width of the tow road is twelve feet ten inches (12 ft 10 in.) with a thickness of six inches (6 in.). A steel rail is embedded in the approach surface to provide vehicle guidance. Vehicle tow propulsion is provided by a  $\frac{3}{4}$  ton truck using a 2 to 1 pulley system coupled to a fixed prime mover (an internal combustion engine, Chevrolet V-8, 454 cubic inches displacement, with T-400 automatic transmission) and continuous cable drive system. The test vehicle is towed to within two feet of the test article by a nylon rope clamped to a  $\frac{3}{8}$  inch steel cable. The clamp is released from the cable on contact with a cable release mechanism positioned to allow the test vehicle to proceed under its own momentum for the final twenty feet of travel before impacting the test series.

### 1.3 TEST ARTICLE

The tested devices consist of a series of twenty (20) concrete redirective longitudinal barriers. Each test article is a 1065 mm high F-shape with a 660 mm wide base and a 230 mm wide top. Barrier segments are 3.023 m long and are connected with 7.9 mm thick perforated C-shapes that, when meshed with opposing ends, forms eight points of connection. Connecting the C-shapes is a 27 x 3 x 760 mm barrier end bolt conforming to ASTM A449. The C-shapes and bolts are hot-dip galvanized after fabrication. The allowable gap between matched barrier ends is 25mm. Reinforcement consists of seven equally spaced 13 mm longitudinals on each face, tied to end U-bars. The longitudinals are tied to nineteen 13 mm vertical stirrup pairs of varied spacings. A diagram of the Tall F-shape Concrete Median Barrier is presented in Appendix C, Page C-3.



SECTION 3  
TEST RESULTS AND DATA SHEETS

3.1 TEST NO. 4-12

This eighty kilometers per hour (80 km/h) crash test was conducted using a 1995 Ford F-800 Box truck to determine if the tested concrete median barriers (CMB) meet the minimum performance standards of the NCHRP 350 recommendations for test level 4 redirective longitudinal barriers. NCHRP 350 Test 4-12 is intended to evaluate occupant risk and vehicle trajectory evaluation criteria with an angled impact of a type 8000S vehicle impacting at the mid-point of the CMB. This test is also intended to evaluate strength of the section in containing and redirecting the 8000S test vehicle.

The test vehicle was aligned such that the edges of the longitudinal barriers were impacted by the right front bumper of the test vehicle. This crash test was documented by one (1) real-time panning motion picture camera and five (5) high-speed motion picture cameras. Pre- and post-test photographs of the vehicle and crash cushions can be found in Appendix A (Figures 1 thru 12).

Test 4-12 was conducted on September 20, 2001. The test inertial weight of the vehicle was 7,917 kg (17,454 lbs.) and its gross static weight was also 7,917 kg (17,454 lbs.). The height to the lower edge of the front bumper was 500 mm (19.69 in.) and the upper edge was 730 mm (28.74 in.). Additional dimensions and vehicle information are presented in Data Sheet No. 1.

The test vehicle impacted the eighth rail in the concrete rail series at a velocity of 76.06 km/h (47.27 mph). The vehicle remained in physical contact with the longitudinal barrier series for approximately 1400 msec. The vehicle rotated on its axis approximately seven point three degrees (7.3°), was re-directed to the left of the barriers, turned back towards the barriers as the right front tire deflated, and came to rest approximately 6.1 meters to the left of and 41.1 meters beyond the critical impact, as shown in Figures 2, 4 and 6. Sequential photographs of the test sequence are shown in Appendix D. The vehicle sustained moderate damage to the right side bumper and right front fender as a result of the impact with the redirective longitudinal barriers; the right front tire was damaged and deflated after the impact. The vehicle sustained minor damage to the box trailer. Maximum vehicle crush at the bumper height was indeterminate. Post-test photographs of the test vehicle are presented in Appendix A.

There was no unacceptable deformation or intrusion into the vehicle occupant compartment.

Ten (10) of the barriers were displaced by the impact. The maximum depth of the movement of the longitudinal barriers was 826 mm (32.5 in.). Barriers 6 and 14 were shifted 19 mm ( $\frac{3}{4}$  in.) and 51 mm (2 in.), respectively, opposite the direction of impact, as opposed to barriers 5 and 7 through 13, which were moved and angled in the direction of the impact. A summary of the electronic data is presented in data Sheet No. 2. Data plots are presented in Appendix B. Table 4 (Section 4) shows the NCHRP Report 350 evaluation criteria and the performance assessment of this installation with respect to those criteria.

DATA SHEET NO. 1

VEHICLE PROPERTIES FOR TEST NO. 4-12

DATE	<b>09/20/01</b>	COLOR	<b>WHITE</b>	VIN	<b>1FDNF60H7FVA20332</b>
YEAR	<b>1995</b>	MAKE	<b>FORD</b>	MODEL	<b>F-800 BOX</b>
TIRE PRESSURE (psi)	<b>85/75</b>	ODOMETER (mi.)	<b>269351</b>	TIRE SIZE	<b>8.25 x 20E</b>
ENGINE	<b>FRONT</b>	CYLINDERS	<b>8</b>	DISPLACEMENT	<b>6.1 LITER</b>
TRANSMISSION	<b>4-SPEED</b>	AUTOMATIC	<b>NO</b>	MANUAL	<b>YES</b>
DESCRIBE ANY DAMAGE TO VEHICLE PRIOR TO TEST:			<b>MINOR SCRATCHES, ETC.</b>		

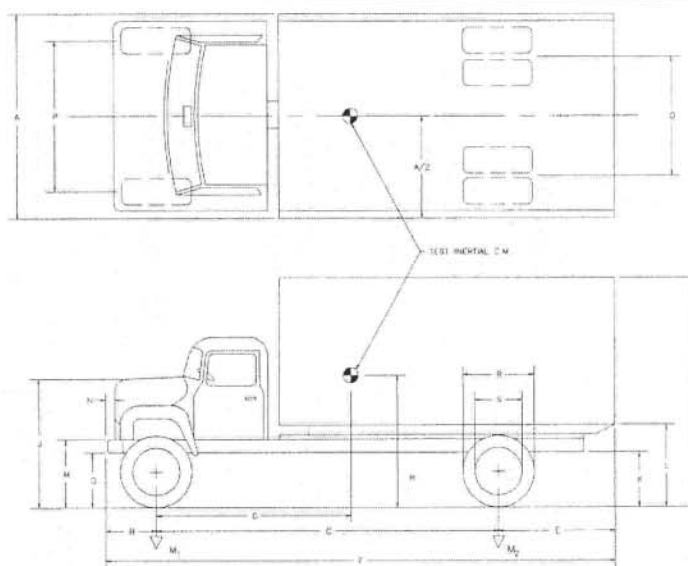

TEST VEHICLE GEOMETRY (mm)							
A	<b>2650</b>	F	<b>8750</b>	L	<b>940</b>	Q	<b>2050</b>
B	<b>860</b>	G	<b>3068</b>	M	<b>730</b>	R	<b>970</b>
C	<b>5290</b>	H	<b>N/A</b>	N	<b>50</b>	S	<b>580</b>
D	<b>3530</b>	J	<b>1530</b>	O	<b>420</b>	-	<b>-</b>
E	<b>2600</b>	K	<b>620</b>	P	<b>2050</b>	-	<b>-</b>

MASS DISTRIBUTION							
LEFT FRONT	<b>971 kg (2140 lb)</b>	RIGHT FRONT	<b>963 kg (2122 lb)</b>	LEFT REAR	<b>1228 kg (2708 lb)</b>	RIGHT REAR	<b>1150 kg (2536 lb)</b>
MASS (kg)		CURB		TEST INERTIAL		GROSS STATIC	
FRONT AXLE		<b>1933 kg (4262 lb)</b>		<b>3359 kg (7406 lb)</b>		<b>3359 kg (7406 lb)</b>	
REAR AXLE		<b>2379 kg (5244 lb)</b>		<b>4558 kg (10048 lb)</b>		<b>4558 kg (10048 lb)</b>	
TOTAL VEHICLE		<b>4312 kg (9506 lb)</b>		<b>7917 kg (17454 lb)</b>		<b>7917 kg (17454 lb)</b>	

DATA SHEET NO. 2

SUMMARY OF RESULTS FOR TEST NO. 4-12

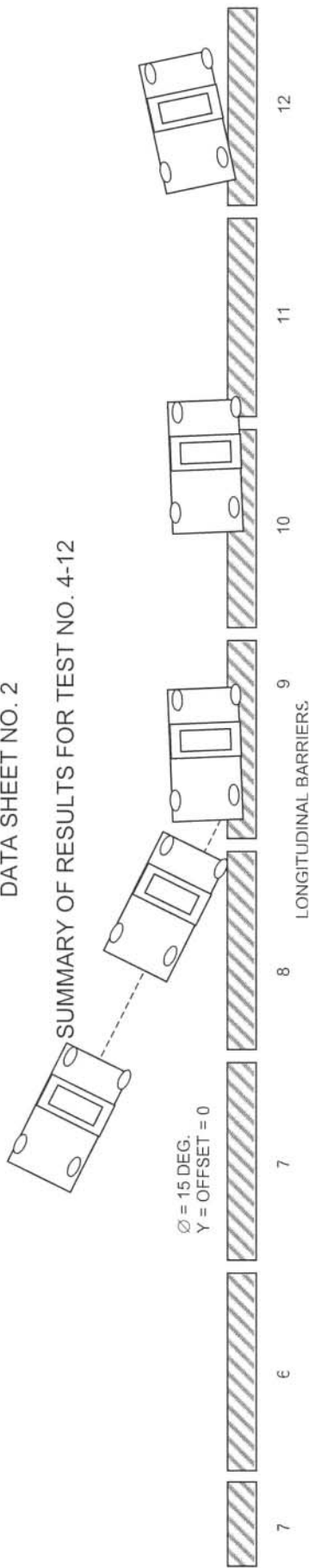

GENERAL INFORMATION		OCCUPANT RISK VALUES	
TEST AGENCY	KARCO ENGINEERING	IMPACT VELOCITY (m/sec)	
TEST NO.	4-12	X-DIRECTION	1.87 m/sec
DATE	09/20/01	Y-DIRECTION	2.74 m/sec
TEST ARTICLE		THIV (optional)	N/A
TYPE	LONGITUDINAL BARRIERS	RIEDOWN ACCELERATION (g's)	
INSTALLATION LENGTH (m)	60.96 m (200 ft.) precast concrete	X-DIRECTION	+ 4.67 to -5.29
SIZE AND/OR DIMENSION OF KEY ELEMENTS	3.023 m (9 ft 11 in.)	Y-DIRECTION	+ 4.47 to -6.78
SOIL TYPE AND CONDITION	N/A	PHD (optional)	N/A
TEST VEHICLE		ASI (optional)	0.514
TYPE	PRODUCTION	TEST ARTICLE DEFLECTIONS (m)	
DESIGNATION	8000S	DYNAMIC	32.5 in.
MODEL	1995 FORD F-600 BOX TRUCK	PERMANENT	32.5 in.
MASS (CURB)	4312 kg	VEHICLE DAMAGE	
MASS (TEST INERTIAL)	7917 kg	EXTERIOR	
DUMMY(S) MASS	N/A	VDS	n/a
GROSS STATIC WEIGHT	7917 kg	CDC	n/a
IMPACT CONDITIONS		INTERIOR	
SPEED (km/h)	76.06 km/h (47.27 mph)	OCDI	n/a
ANGLE (Deg.)	15°		
IMPACT SEVERITY (k-j)	N/A	POST IMPACT VEHICULAR BEHAVIOR	
EXIT CONDITIONS		MAXIMUM ROLL ANGLE (Deg.)	+ 0.24 to -9.50
SPEED (km/h)	N/A	MAXIMUM PITCH ANGLE (Deg.)	+ 8.44 to -1.06
ANGLE (Deg.)	7.3°	MAXIMUM YAW ANGLE (Deg.)	+ 0.00 to -25.79