

APPROVED

By Randy Trox, REHS at 12:02 pm, Mar 04, 2019

LOWeFLOW -OR

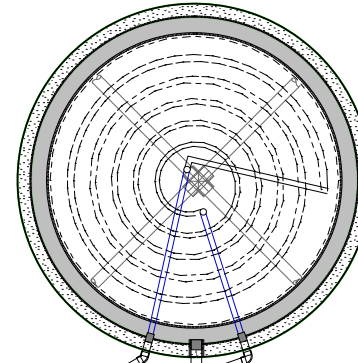

LF-500 Treatment Unit

Preceded by an Oregon DEQ Approved Tank

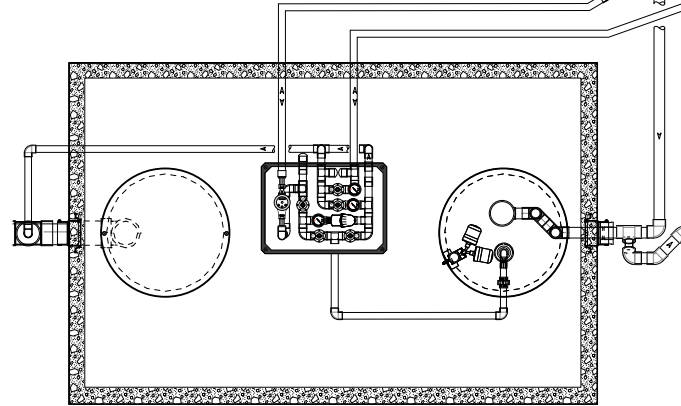

Followed by an Oregon DEQ Approved Pump Tank or Drainfield

1000 Gallon Pre-cast Concrete Single Compartment Recirc Tank

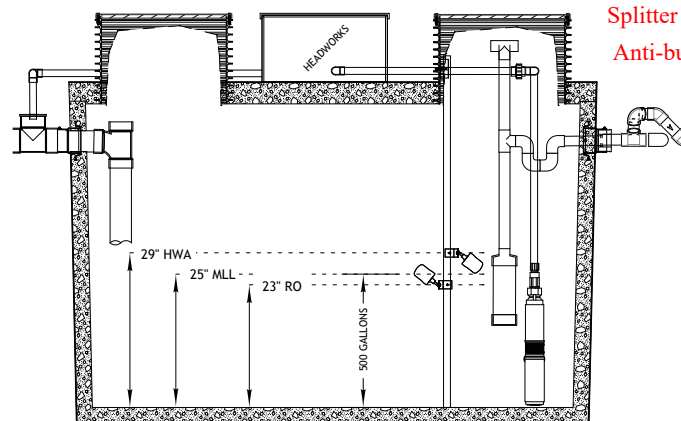

Splitter Tee handle capped to prevent bypassing in event of pump failure
Anti-buoyancy may be required per tank manufacturer

Preceded by an Oregon DEQ Approved Tank

Followed by an Oregon DEQ Approved Pump Tank or Drainfield

CROSS SECTION

LOWRIDGE ONSITE TECHNOLOGIES

DRAWING ID: LOWEFLOW 500 GPD

SCALE: NTS

DRAWN BY: DBM

CK BY: DAVE LOWE

DATE: 01.29.2019

LF-500-OR

APPROVED

By Randy Trox, REHS at 12:07 pm, Mar 04, 2019

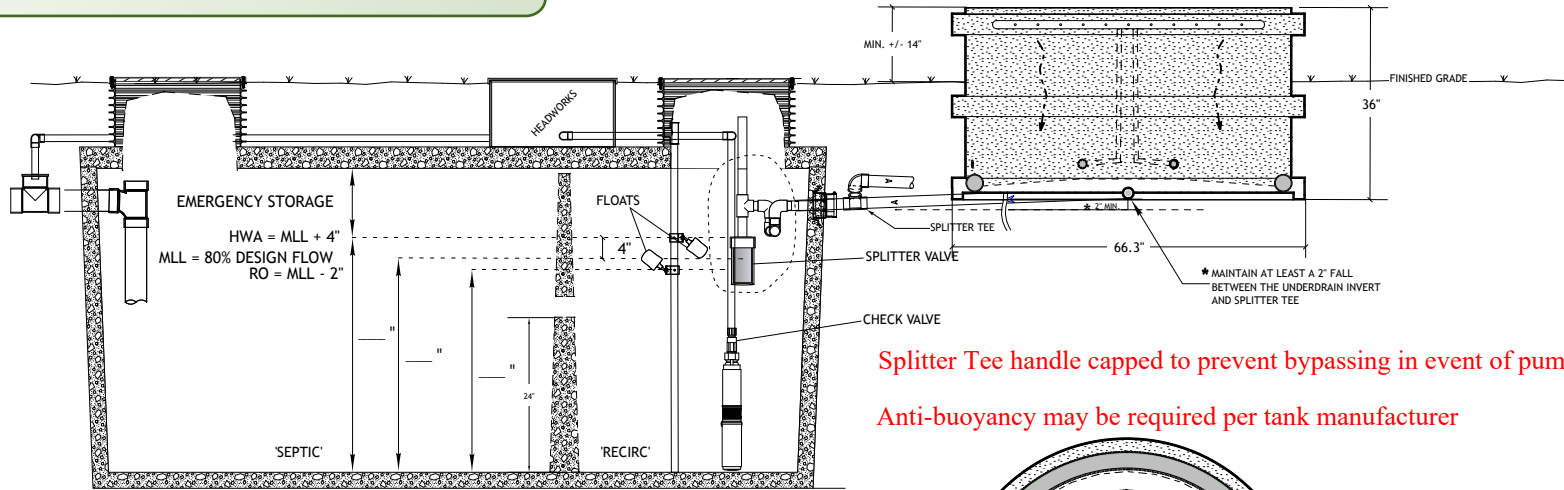

Splitter Tee handle capped to prevent bypassing in event of pump failure
 Anti-buoyancy may be required per tank manufacturer

CROSS SECTION
NTS

1500 GALLON, DOUBLE
COMPARTMENT CONCRETE TANK

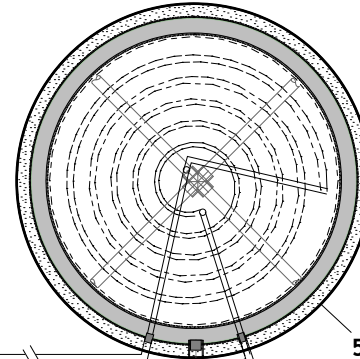

500 GPD LOWFLOW FILTER

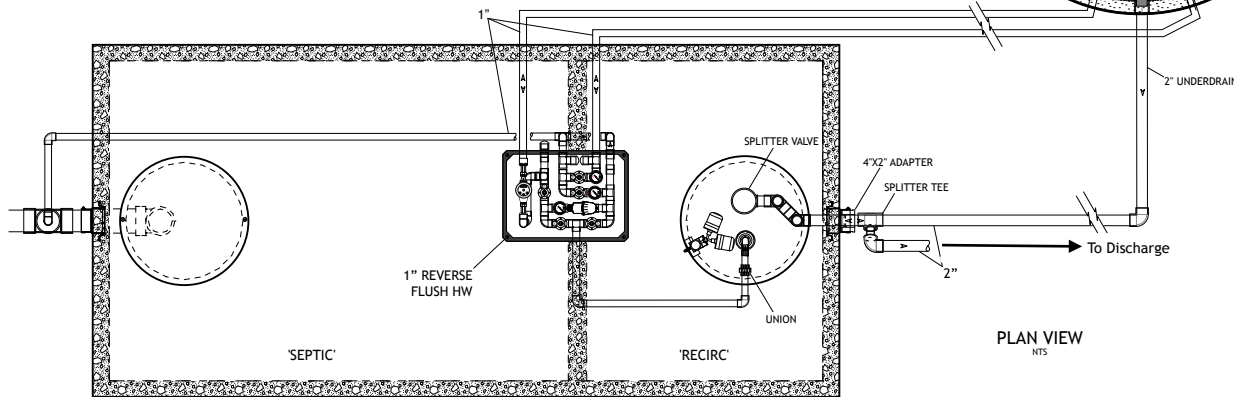

PLAN VIEW
NTS

LOWRIDGE ONSITE TECHNOLOGIES

DRAWING ID: LF-500-OR

SCALE: NTS

DRAWN BY: DBM

CK BY: DAVE LOWE

DATE: 01.29.2019