

Oregon DEQ Aquatic Life Use Updates

Rule Advisory Committee Meeting #5



1. Welcome and Introduction

Aug. 24, 2022

Welcome!



Zoom meeting logistics

- Trina Brown – DEQ Admin. Support
- “Raise hand” to be recognized for questions or comments  
- Feel free to post questions into the chat and we will respond
- If you are listening on the phone:
 - Press *9 To raise your hand
 - Press *6 Unmute/Mute your line
- Today’s meeting will be recorded

Agenda

Time	Topic
9 a.m.	Welcome, Introduction
9:20 a.m.	Final Draft, Fiscal Impact Statement Q&A and Discussion
9:50 a.m.	Technical Support Document Q&A
10:20 a.m.	Break (10 mins)
10:30 a.m.	Aquatic Life Definitions Revisions
10:50 a.m.	Wrap Up, Next Steps, Final Q&A
11:30 a.m.	Adjourn meeting

Meeting Objective

- Present and discuss proposal for revising Aquatic Life Use Definitions
- Q&A and Discussion
 - Technical Methods
 - Final Draft Fiscal Impact Statement
- Highlight final opportunities for comments before draft rule finalization

Discussion Ground Rules

- Questions and interjections from committee members only please
- Will reserve a portion at end of meeting for questions from observers if time permits
- Be respectful of each other
- Raise your virtual hand to speak
- Speak for yourself when recognized
- Stay on mute unless speaking
- Stay on topic in the chat
- Let others speak without interrupting

Questions about today's meeting?



Image Source: ODFW

Oregon DEQ Aquatic Life Use Updates

Rule Advisory Committee Meeting #5

2. Fiscal and Economic Impacts

August 24, 2022

Comments Received- Thanks!

- DEQ obtained comments from the following members of the advisory committee:
 - Deschutes River Alliance
 - NW Pulp and Paper Association
 - Oregon Association of Clean Water Agencies
 - Oregon Farm Bureau
 - Oregon Forest Industries Council
 - Pacific Coast Federation of Fishermen's Associations
 - Portland General Electric
 - Portland Water Bureau
 - Trout Unlimited

Proposed Rule Overview

- Proposed rules protect existing uses, salmonid populations, and other aquatic life
- Use best available scientific information to more accurately designate uses
- Increases protection in waters where current uses were not correctly identified or sufficient

Added Items Since RAC #4

- 31 of NPDES permitted facilities are POTWs
 - Facility needs are each unique and site specific, unknown costs
 - If more stringent limits, treatment options and current facility operations may need to change
 - If less stringent limits, cost savings are possible
- 3 large businesses which may be impacted by temp rule
- 1 small business which may be impacted by temp rule

Addressed all comments in FIS

- Incorporated comments that were within the scope of fiscal impacts
- Additional comments were either incorporated or responded to in the document

Overall Effects

- Possible positive and/or negative effects, costs largely unknown
- Updates to the subcategories will result in more stringent AND less stringent criteria
 - Most waters will not change designations
- ~ 43 NPDES-permitted facilities may be directly affected by criteria
 - 38 possibly impacted by temp criteria; 5 possibly impacted by DO criteria
 - Permitted dischargers may have increased costs with more stringent criteria
- May be a positive impact on tribal interests, recreational/commercial fisheries, jobs, water quality, water treatment costs

Questions and Discussion



Oregon DEQ Aquatic Life Use Updates Rulemaking Advisory Committee Meeting #5

3. Technical Support Document Q&A

Aug. 24, 2022

Purpose of Document

Document information supporting new 'decision rule' methods to designate the aquatic life use subcategories

- Documentation
- Analysis
- Procedures
- Literature review

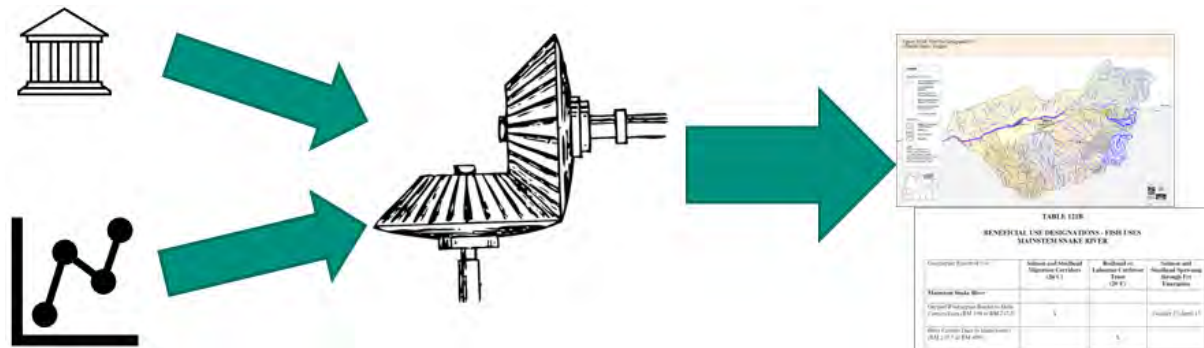

Expectations for Feedback

- Purpose to inform and provide context to stakeholders.
- DEQ developed methods and analyses with Technical Workgroup.
- Interested in feedback that helps clarify and communicate the information.
- Please notify DEQ of major concerns ASAP.
- Unlikely to entertain changes to final methods at this time.

Initial questions about the Technical Support Document?

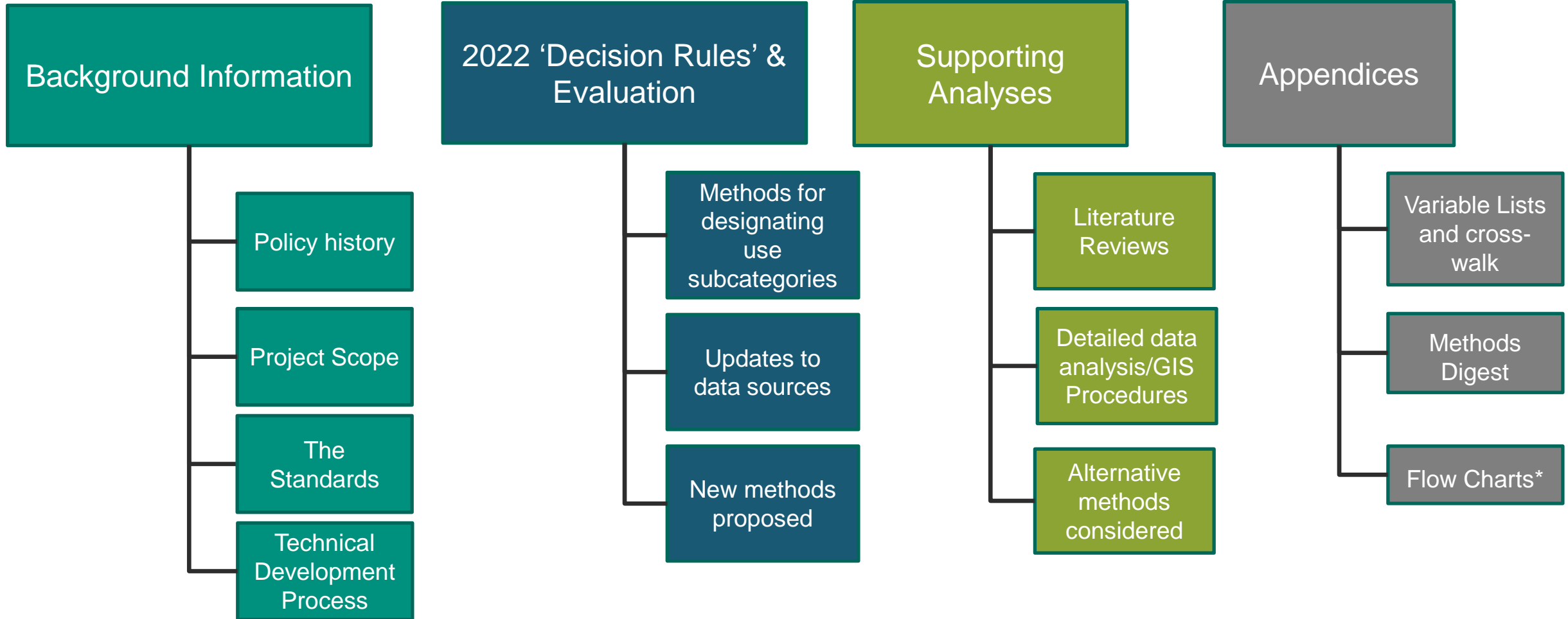

Next Steps

- Final opportunity to provide input until **September 15.**
- Staff available to answer questions in meantime:
 - Contact James: james.mcconaghie@deq.oregon.gov
- Send written input to aquaticlife.2022@deq.oregon.gov

Further Questions?



Image Source: ODFW

Oregon DEQ Aquatic Life Use Updates Rule Advisory Committee Meeting #5

4. Amendments to Definitions Rule:
“Cold water aquatic life” and “Cool water aquatic life”

Aug. 24, 2022

Background on terms

OAR 340-041-0002 (9) and (12)

“Cold water aquatic life” and “Cool water aquatic life”

- In general definitions rule (Part -0002)
- Identifies examples of fish species classified as cold or cool based on thermal tolerance
- Adopted in 2003, with temperature standard revisions

The Issue

- Terms and definitions in Part -0002 could be read as redefining the dissolved oxygen use categories in Table 21
- In a way that is inconsistent with the definitions in the dissolved oxygen rule itself.

Proposal

Revise the terms in the general definitions rule as shown:

(9) "Cold-Water **Species**~~Aquatic Life~~" means aquatic organisms that are physiologically restricted to cold water including, but not limited to, native salmon, steelhead, mountain whitefish, char including bull trout, and trout.

(12) "Cool-Water **Species**~~Aquatic Life~~" means aquatic organisms that are physiologically restricted to cool waters including, but not limited to, native sturgeon, Pacific lamprey, suckers, chub, sculpins and certain species of cyprinids (minnows.)

Rationale

- The definitions more accurately match terms:
 - “cold water species”
 - “cool water species”
- Removes confusion with use subcategories of D.O.
OAR 340-041-0016 Table 21
- The term “cool water species” is also used in the temperature standard

Alternative considered

- Remove the terms from the general definitions rule
 - rely on the terminology in the temperature and DO standard rules
 - Define the use subcategories

Possible effects of proposed amendment

- Improved clarity by removing difference in terms
- DEQ is designating waterbodies for the D.O. use subcategories in rule in this rulemaking
- The definitions in OAR 340-041-0002 are not needed in order to apply the D.O. standard

Questions



Appearance of Terms

OAR-340-041-0002 "Definitions"	OAR-340-041-0016 Table 21 "D.O. Rule"	OAR-340-041-0028 "Temperature Rule"
(9) Cold-Water Aquatic Life	Cold-water aquatic life	Not used.
(12) Cool Water Aquatic Life	Cool-water aquatic life	(9) Cool Water Species

Oregon DEQ Aquatic Life Use Updates Rule Advisory Committee Meeting #3

6. Wrap Up and Adjournment

Aug. 24, 2022

Thank you!



Remaining Opportunities for RAC Input:

- DEQ will send:
 - Draft meeting summary will be provided to the group
~1 week for review and corrections
 - Short issue paper for Aquatic Life Definitions Revision
- RAC provide any comments on TSD
- Send any final input by **September 15.**
- Send comments to: aquaticlife.2022@deq.oregon.gov
- Staff available to answer questions about any documents in meantime.
 - Contact James: james.mcconaghie@deq.oregon.gov

Project Schedule

Policy Creation & Rule Adoption Phase

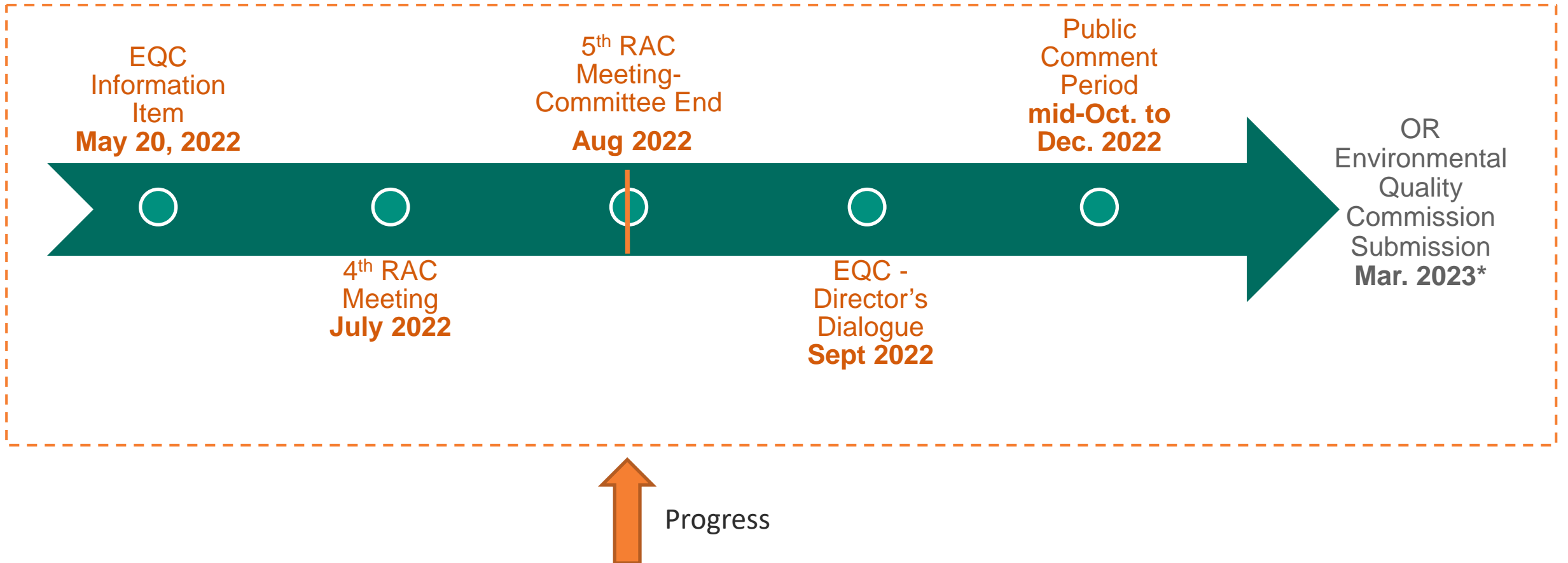

Questions before Adjournment?



Image source: NOAA Photo Library



Thank you

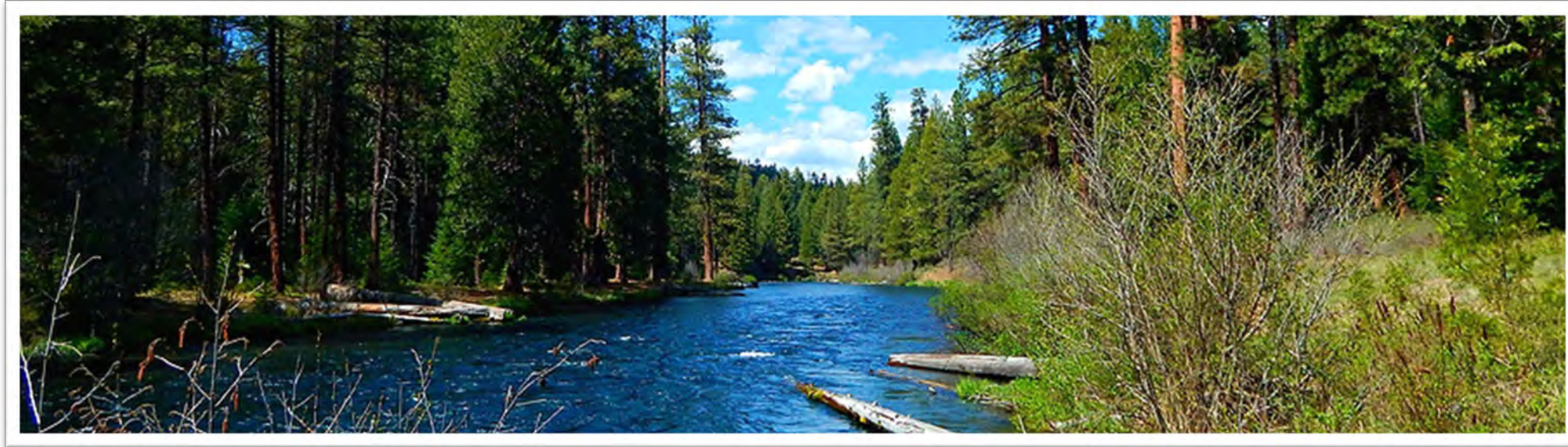

Metolius River,
Oregon

Aquatic Life Rulemaking: aquaticlife.2022@deq.oregon.gov

James McConaghie, Aquatic Life Use Updates Project Lead:

james.mcconaghie@deq.oregon.gov or call (503) 229-5619

Website: <https://www.oregon.gov/deq/rulemaking/Pages/aquaticlife2022.aspx>