

VERSION JUNE 2020

6/1/2020



BRIDGE DESIGN MANUAL

INTRODUCTION

BRIDGE ENGINEERING SECTION

OREGON DEPARTMENT OF TRANSPORTATION

Table of Contents

INTRODUCTION.....	1
Preface	1
Organization of the Manual	2
Revising the Manual	3

Note: Revisions for **June 2020** are marked with **yellow highlight**. Deleted text is not marked; past editions of the BDM are available for comparison at <http://www.oregon.gov/ODOT/Bridge/Pages/Bridge-Design-Manual.aspx>

INTRODUCTION

PREFACE

The *Bridge Design Manual (BDM)* provides a reference for those involved in preparing ODOT bridge design deliverables. The purpose of the manual is to:

- Provide guidance in design standards and detailing practices (Section 1).
- Provide guidance in selective design, and bridge type selection and geometric layout (Section 2).
- Provide guidance in bridge design roles and responsibilities, design and quality processes, and items to coordinate with other disciplines (Section 3).

An effort has been made to make the *Bridge Design Manual* informative, comprehensive, and accurate. It is a guide to acceptable ODOT practices. The manual should be used in the design of State Highway bridges. Use on other bridges in the State of Oregon should only be as noted in this manual, or as directed by the bridge owner.

The manual is not a legal document. There is no substitute for sound engineering judgment.

Bridge Design Manual users are encouraged to submit comments, corrections, and proposals for new or revised materials.

Any comments or questions about the *Bridge Design Manual* should be directed to:

Bridge Design Standards Engineer
Oregon Department of Transportation
Technical Services – Bridge Engineering Section
4040 Fairview Industrial Drive S.E., MS #4
Salem, OR 97302-1142
(503) 986-4200
Rebecca.BURROW@odot.state.or.us

ORGANIZATION OF THE MANUAL

The *Bridge Design Manual* is divided into three main sections:

- Section 1: Design Standards and Detailing Practices
- Section 2: Design Guidance, Type Selection and Layout
- Section 3: Processes, Roles

The acronym “BDM” and a number refers to a section, subsection, etc., of this *Manual* unless another reference is specifically called out. So, you will see *BDM 2.1*, *BDM 2.1.1.1(1)*, etc.

The acronym “BCM” and a number refers to a section of the *Bridge CAD Manual*.

The acronym “LRFD” and a number refers to a section of the *AASHTO LRFD Bridge Design Specifications*.

The acronym “SP” and a number refers to a section of the *ODOT Construction Specifications*.

Except for the “Introduction”, each Section has:

- Main body of text
- Appendix

The page numbers of the Section’s text are prefixed with the Section number. Thus, for Section 2, the page numbers are 2-1, 2-2, etc.

The Table of Contents is linked to the Section’s text for Sections 1, 2 and 3. The “Bookmark” navigation function is active in all Sections. Also, the “Search” and “Find” functions enable fairly rapid location of topics.

Tables, charts, and examples of forms are all identified as alphanumeric “Figures”. The figure number refers to the specific section number where the figure is mentioned:

- Figure 2.1.1 is the only figure mentioned in Section 2.1.1 and inserted in or closely after the Section 2.1.1 text.
- Figure 2.1.1A is the first figure of a series of figures mentioned in Section 2.1.1 and inserted in or closely after the Section 2.1.1 text.
- Figure A2.3.2A is in the Section 2 Appendix and mentioned in Section 2.3.2.

For the sake of brevity or in order to use a familiar term in place of an unfamiliar “official” version, some editorial liberties have been taken when referring to organizational names or titles:

Manual
Bridge Section or Bridge HQ
Roadway Section
Traffic Section
Region Tech Center

Official
Bridge Engineering Section
Roadway Engineering Section
Traffic Management Section
Regional Technical Centers

REVISING THE MANUAL

Only the Bridge Design Standards and Practices Engineer, Bridge Standards Technical Specialists, or the State Bridge Engineer (or his/her designee) are to circulate communications concerning matters of or revisions to design practices.

(1) Put It in Writing - Research and develop a written proposal using three general subject headings:

- Problem Statement
- Proposal
- Analysis / Research / and Other Supporting Data

A template letter is shown at the [end of this Section](#). An electronic version of this template can be found on the BDM webpage at <http://www.oregon.gov/ODOT/Bridge/Pages/Bridge-Forms.aspx>

Complete your written proposal and submit directly to the Bridge Design Standards and Practices Engineer at the address or email shown in the Preface.

(2) Review and Approval - After reviewing a written proposal for completeness, the Design Standards and Practices Engineer will:

- Acknowledge receipt of the proposal and provide an initial assessment response:
 - Accepted for consideration as submitted
 - Accepted for consideration as noted
 - Proposal tabled, see Remarks
 - Proposal not accepted, see Remarks
- For accepted proposals, post the proposal on the BDM webpage **and Projectwise Folder** for review and comment.

After the review period, responses to comments will be prepared. The Standards Engineer will see that one of the following is done:

- Proposals with resolved comments will be included in the BDM.
- Proposals without resolved comments will be tabled (and possibly reconsidered at a future update should the proposer so elect).

Proposals will be forwarded to the FHWA (Federal Highway Administration) for review, comments and approval. Any FHWA comments on a proposal will be reviewed and given a final approval.

(3) Implementation of Approved Revision - After a proposal has final approval, the Standards Engineer will include it in the Manual update on the Bridge Engineering web page. Revised or added text will be highlighted in yellow. If a revision is urgent, it may be distributed immediately in a Technical Bulletin and incorporated into the BDM later.

**ODOT BRIDGE DESIGN
MANUAL
REVISION REQUEST**

TECHNICAL SERVICES
Bridge Engineering Section
Office Phone: (503) 986-4200
Fax Number: (503) 986-3407

DATE: Month XX, 20XX

TO: Rebecca Burrow
Bridge Design Standards Engineer

FROM: [Name] Phone#: xxx-xxx-xxxx
[Position Title]
[Firm]

SUBJECT: Proposed Revision to Bridge Design Manual

RE: BDM Section x.x.x.x –

Problem Statement:

Proposal:

Modify/Add Section x.x.x.x as follows:

Analysis / Research / Other Supporting Data:

- None
- Attached:

Bridge Engineering Section Response:

<input type="checkbox"/> Accepted for consideration as submitted	<input type="checkbox"/> Accepted for consideration as noted	
<input type="checkbox"/> Proposal tabled, see Remarks	<input type="checkbox"/> Proposal not accepted, see Remarks	
Remarks:		
[Name of Author] [Title of Engineer Author]		Date
[Name of Reviewer] Bridge Design Standards Reviewer		Date

Cc: file

VERSION JUNE 2020

6/1/2020



BRIDGE DESIGN MANUAL

SECTION 1: DESIGN STANDARDS

BRIDGE ENGINEERING SECTION

OREGON DEPARTMENT OF TRANSPORTATION

Table of Contents

1.1	Section 1 – Introduction	5
1.2	Bridge Design, General	6
1.2.1	Bridge Design Standards	6
1.2.2	Bridge Design Deviations and Design Exceptions	7
1.2.3	Bridge Design Deliverables	8
1.2.4	Bridge Design Procedures	9
1.3	Loads and Distributions	10
1.3.1	Dead Loads	10
1.3.2	Live Loads	11
1.3.3	Sidewalk Loading	16
1.3.4	Vehicular Collision Forces: CT	17
1.3.5	Change in Foundations Due to Limit State for Scour	20
1.3.6	Thermal Forces	20
1.3.7	Wind Load	20
1.4	Structural Analysis	21
1.4.1	Ductility, Redundancy and Operational Importance (LRFD 1.3.3, 1.3.4 & 1.3.5)	21
1.4.2	Shear Correction Factor for Skewed Girders	21
1.5	Concrete	22
1.5.1	Concrete, General	22
1.5.2	Concrete Finish	23
1.5.3	Concrete Bonding Agents	25
1.5.4	Curing Concrete	25
1.5.5	Reinforcement	26
1.5.6	Precast Prestressed Concrete Elements	45
1.5.7	Cast-In-Place Superstructure	56
1.5.8	Post-Tensioned Structures	61
1.5.9	Camber Diagrams	69
1.5.10	Pour Schedules	71
1.6	Steel Structure Design and Detailing	75
1.6.1	Steel Girders.....	75
1.6.2	Welding.....	104
1.6.3	Galvanizing and Painting.....	109
1.6.4	Bolts and Connections	113
1.7	Aluminum	114
1.7.1	Aluminum.....	114
1.8	Timber Bridge Design and Detailing	115
1.8.1	Timber Bridge Locations	115
1.8.2	Timber Design and Details	115
1.8.3	Timber Connections	116
1.8.4	Timber Rails	116
1.8.5	Preservative Treatments	116
1.8.6	Field Installation.....	116
1.9	Decks	117
1.9.1	Design and Detailing	117
1.9.2	Deck Screeding	128
1.9.3	Deck Construction Joints.....	129
1.9.4	Deck Overlays	130

1.10	Foundation Considerations.....	141
1.10.1	Foundations, General.....	141
1.10.2	Lateral Earth Restraint.....	141
1.10.3	Underwater Construction.....	142
1.10.4	Foundation Modeling (Foundation Springs).....	143
1.10.5	Foundation Design.....	161
1.11	Substructures.....	182
1.11.1	Retaining Structures, General.....	182
1.11.2	End Bents.....	182
1.11.3	Interior Bents.....	199
1.12	Buried Structures.....	213
1.12.1	Culvert Design, General.....	213
1.12.2	Tunnels (structural elements).....	213
1.13	Rails, Impact Attenuators, and Protective Screening.....	214
1.13.1	Bridge Rail.....	214
1.13.2	Bridge Rail Replacement & Retrofit Guidelines.....	226
1.13.3	Impact Attenuators or Crash Cushions.....	232
1.13.4	Protective Screening or Protective Fencing.....	232
1.14	Bearings and Expansion Joints.....	239
1.14.1	Bearings.....	239
1.14.2	Expansion Joints.....	247
1.15	Soundwalls.....	253
1.15.1	Soundwalls, General.....	253
1.15.2	Soundwalls mounted on Bridges.....	253
1.16	ADA Compliance for Bridge Work.....	254
1.16.1	Americans with Disabilities Act Compliance for Bridge Projects.....	254
1.16.2	General Guidance.....	254
1.16.3	Work Activity Triggers.....	255
1.16.4	Design Considerations.....	258
1.17	Seismic Design.....	260
1.17.1	Design Philosophy.....	260
1.17.2	Applications of AASHTO LRFD Bridge Design Specifications.....	261
1.17.3	Applications of AASHTO Guide Specs for LRFD Seismic Bridge Design.....	271
1.17.4	Liquefaction Evaluation and Mitigation Procedures.....	277
1.17.5	Costs.....	279
1.17.6	Instrumentation.....	279
1.17.7	Dynamic Isolators.....	279
1.17.8	Seismic Restrainer Design (New Designs and Retrofits).....	280
1.18	FRP Composites.....	285
1.18.1	FRP Composites.....	285
1.19	(Reserved).....	286
1.20	Concrete Anchors.....	287
1.20.1	Anchor Bolts / Rods.....	287
1.20.2	Drilled Concrete Anchors.....	288

1.21	Structural Wire Rope (Cables) and Turnbuckles.....	293
1.21.1	Structural Wire Rope (Cables) and Turnbuckles, General	293
1.21.2	General Notes for Structural Wire Rope, Turnbuckles and Connections	294
1.21.3	Special Provisions for Wire Rope	295
1.21.4	Special Provisions for Turnbuckles and Socket Connections	296
1.21.5	Design Properties.....	296
1.22	(Reserved).....	297
1.23	Bridge End Panels, and Slope Paving.....	298
1.23.1	Bridge End Panels and Supports.....	298
1.23.2	Skewed Bridge End Panels	299
1.23.3	Slope Paving/Railroad Slope Protection	300
1.24	Bridge Drainage.....	301
1.24.1	General, Bridge Drainage	301
1.24.2	Standard Design/Drawing/Details	301
1.24.3	Selection Guidance	301
1.24.4	Design Code Guidance.....	301
1.24.5	Design Guidance & Lessons Learned	302
1.24.6	Detailing	303
1.24.7	Construction	305
1.25	Utilities.....	306
1.25.1	General Requirements	306
1.25.2	Design and Detailing Guidelines	307
1.25.3	Providing for Utility Installations	308
1.25.4	Special Utility Considerations	309
1.25.5	Attachments to Existing Bridges	310
1.25.6	Utility Costs and Agreements.....	310
1.26	Corrosion Protection	311
1.26.1	Marine Environment.....	311
1.26.2	Marine Environment Protection.....	311
1.26.3	Deck and End Panel Reinforcement Protection	311
1.26.4	Waterproofing Membranes	314
1.26.5	Protection for Steel Piling.....	315
1.27	On-Bridge Sign & Illumination Mounts.....	318
1.27.1	Traffic Structures Mounted on Bridges, General	318
1.27.2	On-Bridge Sign Mounts.....	318
1.27.3	On-Bridge Illumination Mounts.....	318
1.28	Truss and Monotube Cantilever Sign Bridges.....	319
1.28.1	Truss and Monotube Cantilever Sign Bridges, General	319
1.29	Bridge Raising.....	320
1.29.1	Bridge Raising, General	320
1.29.2	Bridge Raising Using Falsework	320
1.29.3	Bridge Raising Using Chip-in Method	320
1.30	Strengthening of Bridges.....	321
1.30.1	Strengthening of Bridges, General.....	321
1.30.2	Strengthening Methods and Details.....	322
1.31	(Reserved).....	326
1.32	Preservation and Repair	327
1.32.1	Preservation and Repair	327

Bridge Design Manual – June 2020
Oregon Department of Transportation
Section 1 – Design Standards

1.33	Bridge Paint	328
1.33.1	Bridge Paint.....	328
1.34	(Reserved).....	329
1.35	Covered Bridges.....	330
1.35.1	Covered Bridges	330
1.36	Moveable Bridges	331
1.36.1	Moveable Bridges	331
1.37	(Reserved).....	332
1.38	Bridge Temporary Works.....	333
1.38.1	Introduction	333
1.38.2	Temporary Detour Bridges.....	334
1.38.3	Agency Provided Temporary Detour Bridge	336
1.38.4	Falsework.....	336
1.38.5	Shoring.....	339
1.38.6	Cofferdams.....	339
<i>APPENDIX – SECTION 1 – Glossary</i>		<i>345</i>
<i>APPENDIX – SECTION 1 – Abbreviations (Initialisms and Acronyms)</i>		<i>365</i>
<i>APPENDIX – Section 1.2 – AASHTO/BDM Cross-Reference.....</i>		<i>376</i>
<i>APPENDIX – Section 1.11 – Substructures</i>		<i>382</i>
A1.11.1.7	End Bent Details for Prestressed Slabs and Boxes	382
A1.11.2.2	Interior Bent Details for Prestressed Slabs and Boxes	387
<i>APPENDIX – Section 1.20.2.2 – Resin Anchor design.....</i>		<i>390</i>

Note: Revisions for June 2020 are marked with yellow highlight. Deleted text is not marked; past editions of the BDM are available on the Bridge Engineering Section website for comparison.

1.1 SECTION 1 – INTRODUCTION

BDM Section 1 contains standards and practices pertinent to highway bridges and structures design.

See *BDM Section 2* for design guidance pertinent to highway bridges and structures design.

See *BDM Section 3* for standards and practices pertinent to design procedures and quality processes for completing highway bridge and structure design.

See *Bridge CAD Manual (BCM)* for standards and practices pertinent to detailing of highway bridges and structures.

1.2 BRIDGE DESIGN, GENERAL

[1.2.1 Bridge Design Standards](#)

[1.2.2 Bridge Design Deviations](#)

[1.2.3 Bridge Design Deliverables](#)

[1.2.4 Bridge Design Procedures](#)

[1.2.1 Bridge Design Standards](#)

1.2.1.1 Standard Specifications and Standard Drawing Manuals

- *LRFD Bridge Design Specifications* (9th Edition, 2020) published by the American Association of State Highway and Transportation Officials (AASHTO).
- *AASHTO Guide Specifications for LRFD Seismic Bridge Design* (2nd Edition, 2011 with 2012, 2014 and 2015 interims).
- *LRFD Guide Specifications for the Design of Pedestrian Bridges* (2nd Edition, December 2009 with 2015 interims) published by AASHTO.
- *Manual for Railway Engineering* of the American Railway Engineering and Maintenance-of-Way Association (AREMA) as modified by the individual requirements of each railroad company.
- *Oregon Standard Specifications for Construction*, published by ODOT and pertinent special provisions (for all construction except bridges carrying railways).
- *Oregon Standard Drawings*, published by Oregon Department of Transportation, Standards Engineer.

The International Building Code (IBC) as adopted by Oregon does not apply to structures within a public right of way, such as bridges, culverts, retaining walls, traffic structures, signals, sound walls, or railings. Ref: Oregon Structural Specialty Code, Section 101.2.1 General.

1.2.1.2 Use of Oregon Standard Drawing and Standard Details

The Standard Drawings and Standard Details prepared by ODOT have been developed through a long history of collaboration with Oregon contractors and fabricators. Consider impacts to both when making modifications.

Oregon Standard Drawings are to be used without significant change, as determined by the drawing Engineer of Record. Where a significant change to a standard drawing is needed, submit a design deviation request to the State Bridge Engineer. Where an equivalent ODOT Standard Drawing or accompanying design detail exists, do not use Standard Drawings or design details from another state or agency without approval of a design deviation from the State Bridge Engineer.

The Standard Details do not include the seal of the Technical Owner. The Designer or the Engineer of Record (EOR) is responsible for sealing the contract plans with the Standard Details, and the design calculations which is specific to the project where the Standard Details are used.

1.2.2 Bridge Design Deviations and Design Exceptions

Since the bridge design field is an art that is constantly changing, it is understood that designers will occasionally want to use innovative details or methods that may differ substantially from those contained in this manual and on the standard drawings. Designers having experience in other states may also want to introduce details and methods which have worked well in those states.

Submit a request for a design deviation to the State Bridge Engineer before replacing an established drawing or method from this manual. This may include design methods and/or details established in other states, design methods and/or details presented in research reports, or innovative design methods and/or details developed by designers. This requirement is not intended to inhibit innovation or the ability of the designer to exercise good engineering judgment. On the contrary, it is intended to allow good innovative ideas to be used and to potentially become part of this manual.

In cases where a Standard Drawing or BDM design requirement is not applicable to the project circumstances and must be modified, a design deviation is necessary. This commonly occurs to meet a project goal, incorporate new technology or to meet a technical requirement e.g. significant modification to accommodate project geometry; ADA requirements; any modified attachments; existing elements; Local Agency standards; aesthetics. Modifications made in these instances cannot be based on preference or economy. They must be justified by structure geometry, configuration, constructability, and intended purpose. In other words, use a Standard Drawing if it satisfies the need. Ensure changes made to Standard Drawings comply with LRFD and BDM design requirements.

Modifications to Standard Drawings on repair and rehabilitation projects do not require design deviations, except on bridge rail drawings or when new design techniques or materials are used. This is due to the often unique needs of project specific circumstances on rehab and repair projects. These projects must still comply with LRFD and BDM design requirements or a design deviation is necessary. The Bridge Reviewer should devote extra attention to modified drawings and raise concerns to the Standard Drawing owner when appropriate.

Because of federal crash test requirements all projects with modifications to bridge rail require a design exception (refer to ODOT Highway Design Manual Chapter 14 for design exception process as modified by the Design Exception Process Guide, available on the ODOT Bridge Engineering website). A design deviation is not needed when a Design Exception is submitted for the project. However, provide support information to support the Design Exception submittal. Design deviations submitted on projects using new materials and techniques help document their use and incorporate innovative methods into standard practice.

(1) Design Deviations – Prior to submitting a design deviation request, it is prudent to contact the BDM technical specialist for guidance. They can discern when a design deviation is necessary; an e-mail inquiry about the proposed modification suffices for confirmation on whether a formal design deviation is necessary or not.

A design deviation form is available on the [ODOT Bridge Engineering](#) website. In the request, include a brief description of the project, an explanation of the issues, what is being proposed, a justification for the proposed deviation, and any supporting documents. The request may be submitted by e-mail. Send deviation requests to both:

Ray Mabey, State Bridge Engineer, Raymond.MABEY@odot.state.or.us,
Rebecca Burrow, Bridge Standards and Practices Engineer, Rebecca.Burrow@odot.state.or.us

The request will be distributed to and evaluated by the BDM technical specialists. The State Bridge Engineer makes the final decision to accept or reject a request for design deviation. A response to each request will be returned by e-mail within 10 business days.

(2) Technical Bulletins – From time to time, technical issues arise between scheduled BDM updates which require urgent distribution of guidance to the design community. These are handled by Technical Bulletins. Check the ODOT Bridge Engineering web page for status of Technical Bulletins.

1.2.3 Bridge Design Deliverables

1. Bridge Design Quality Plan (may be part of Region Design Quality Plan)
2. Project Startup
 - a. Bridge Design Criteria
 - b. Bridge Design Standard Assessment
 - c. Draft Bridge Design Deviations and Exceptions
 - d. Pre-Design load ratings (if applicable)
3. TS&L Report
 - a. TS&L Memo or TS&L Narrative
 - b. TS&L Plan Sheet(s)
 - c. Engineer's Estimate @ TS&L
 - d. Design Deviations and Exceptions
 - e. 'Approve' Design Deviations and Exceptions
 - f. Alternatives Study supporting data
4. Preliminary Plans Package (70 percent complete)
 - a. Preliminary Plans Plan Sheets
 - b. Engineer's Estimate @ Preliminary Plans
5. Advance Plans Package (95 percent complete)
 - a. Advance Plans Plan Sheets
 - b. Engineer's Estimate @ Advance Plans
 - c. Engineer's Estimate of probable construction schedule (when required by project team)
 - d. Draft Special Provisions
6. Final Plans Package (Sealed Documents ready for Advertisement)
 - a. Final Plans Plan Sheets
 - b. Engineer's Estimate @ Final Plans
 - c. Updated estimate of probable construction schedule (when required by project team)
 - d. Final Special Provisions
7. Calculation Book(s) (at PS&E Milestone and at end of construction)
8. Load Ratings (See ODOT LRFR Manual, at PS&E Milestone and at end of construction)
9. Microstation CAD Files (See *BCM*)
10. Native electronic computer files
 - a. Excel calculation files
 - b. MathCad calculation files
 - c. Structural analysis program files
11. Construction Support documents
 - a. Responses to RFIs
 - b. Shop Drawing Reviews
 - c. Temporary Works Reviews
 - d. Falsework Reviews
 - e. Design Revisions
 - f. Site Visit Notes

1.2.4 Bridge Design Procedures

See *BDM 3* for the following information:

- Design Software
- Overview of Design Procedures
- Roles & Responsibilities
- Quality
- QPL / Research
- Preliminary Design / TS&L
- Final Design / PS&E
- Advertisement & Award
- Construction Support
- Other Discipline Coordination

1.3 LOADS AND DISTRIBUTIONS

[1.3.1 Dead Loads](#)

[1.3.2 Live Loads](#)

[1.3.3 Sidewalk Loading](#)

[1.3.4 Vehicular Collision Force: CT](#)

[1.3.5 Change in Foundations Due to Limit State for Scour](#)

[1.3.6 Thermal Forces](#)

[1.3.7 Wind Load](#)

1.3.1 Dead Loads

General – Knowledge of the capacity of each bridge to carry loads is critical prior to increasing dead load or any change to section properties of main load carrying members. A Load Rating that reflects the current condition of each bridge is a valuable tool that is used to identify the need for load posting or bridge strengthening. Review the latest load rating or conduct load rating for feasibility study of a project at scoping stage.

When the load rating of the existing structure is available check the latest Bridge Inspection conditions' rating report against condition rating used for load rating. Rating of a structure decreases with an increase in dead load and may result in posting of the bridge. Contact the Bridge Program unit when you need assistance in a load rating.

For all non-load-path-redundant steel truss bridges, the designer will verify that the stress levels in all structural elements, including gusset plates, remain within applicable requirements whenever planned modifications or operational changes may increase stresses.

- (1) Box Girder Deck Forms - Where deck forms are not required to be removed, include an allowance of 10 psf for form dead load.
- (2) Shortening - Dead load should include the elastic effects of stressing (pre or post-tensioned) after losses. The long-term effects of shrinkage and creep on indeterminate reinforced concrete structures may be ignored, on the assumption that forces produced by these processes will be relieved by the same processes.
- (3) Utilities - Where holes are provided for future utilities, estimate the dead load of such utilities as that for a water-filled pipe of 2 inches smaller nominal diameter than that of the hole. For 12 inch holes, the dead load may be assumed to be 90 plf.

- (4) Wearing Surface - Provide the following minimum present wearing surface (pws) and future wearing surface (fws) allowances.

	<u>pws</u>	<u>fws</u>
All bridges with CIP concrete decks	0	40 psf (3 inches)
PPC	12 psf (1 inch)	25 psf (2 inches)
Side-by-side construction	0 psf	40 psf (3 inches)

For side-by-side construction with PPC, provide additional pws allowance above the 12 psf as needed to account for crown and superelevation buildup. The 3 inch minimum ACWS thickness is intended to provide sufficient thickness such that future maintenance resurfacing can be performed by removal and replacement of the upper 1.5 inches.

1.3.2 Live Loads

- (1) New Vehicular Traffic Structures - Design by *AASHTO LRFD Bridge Design Specifications* using all of the following loads:

Service and Strength I Limit States:

- HL-93: Design truck (or trucks per *LRFD 3.6.1.3*) or the design tandems and the design lane load.

Strength II Limit State:

- ODOT OR-STP-5BW permit truck
- ODOT OR-STP-4E permit truck

Note: ODOT Permit Loads are shown in *Figure 1.3.2A*. In May 2006, ODOT Permit Load designations were changed as follows:

OR-STP-5B	changed to	OR-STP-4D
OR-STP-5C	changed to	OR-STP-4E
OR-STP-5BW	no change	

Axle weights and axle spacing's did not change, only the designations.

For single-span bridges with prismatic girders, *Figures 1.3.2B to 1.3.2E* are provided to help determine the controlling permit truck for various span lengths.

OREGON PERMIT LOADS FOR STATE OWNED BRIDGES

Indicated concentrations are Axle Loads in Kips

Type OR-STP-4D

8 Axle Vehicle
 Gross Weight = 162.5K

Representative Sample of
 Single Trip Permit in
 Weight Table 4

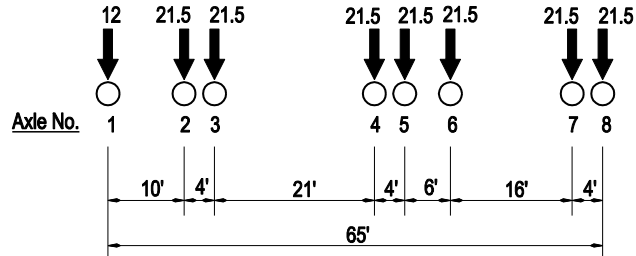

Type OR-STP-5BW

9 Axle Vehicle
 Gross Weight = 204K

Representative Sample of
 Single Trip Permit with Bonus
 Weights in Weight Table 5

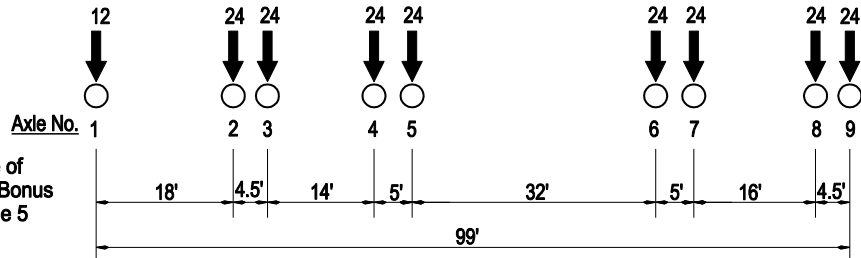

Type OR-STP-4E

13 Axle Vehicle
 Gross Weight = 258K

Representative Sample of
 Single Trip Permit in
 Weight Table 4

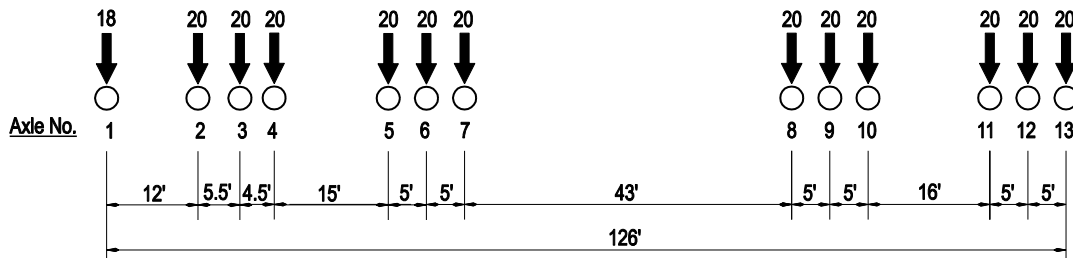

Figure 1.3.2A

Bridge Design Manual – June 2020
Oregon Department of Transportation
Section 1 – Design Standards

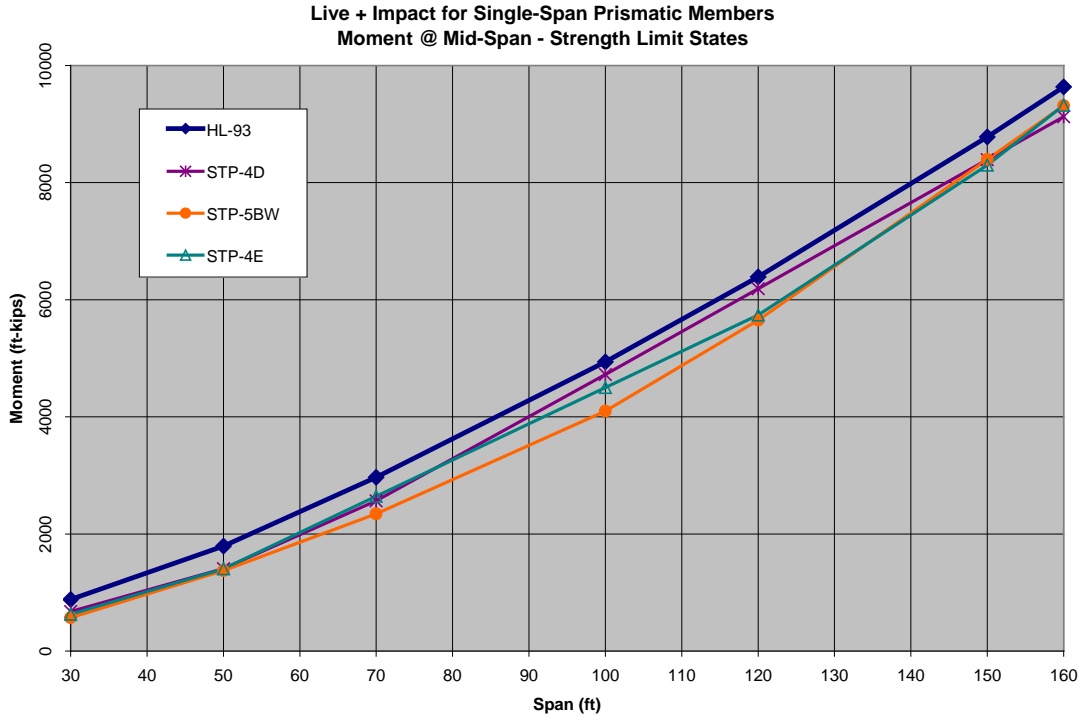

Figure 1.3.2B

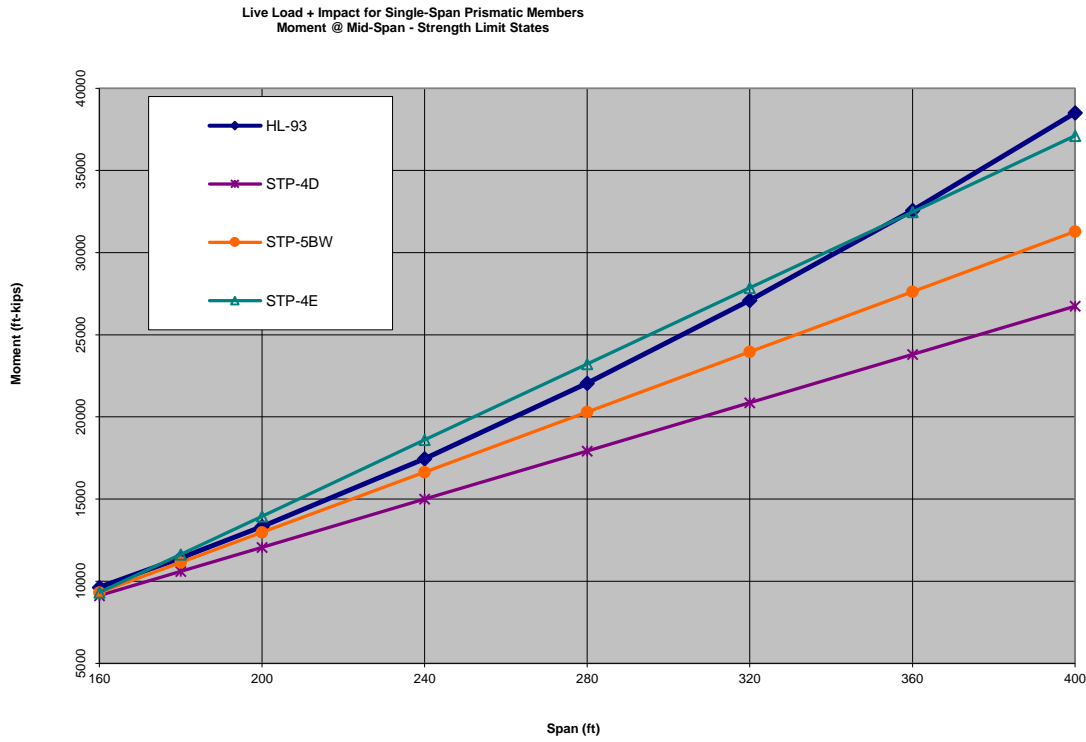

Figure 1.3.2C

Bridge Design Manual – June 2020
Oregon Department of Transportation
Section 1 – Design Standards

Live Load + Impact for Single-Span Prismatic Members
Maximum Shear - Strength Limit States

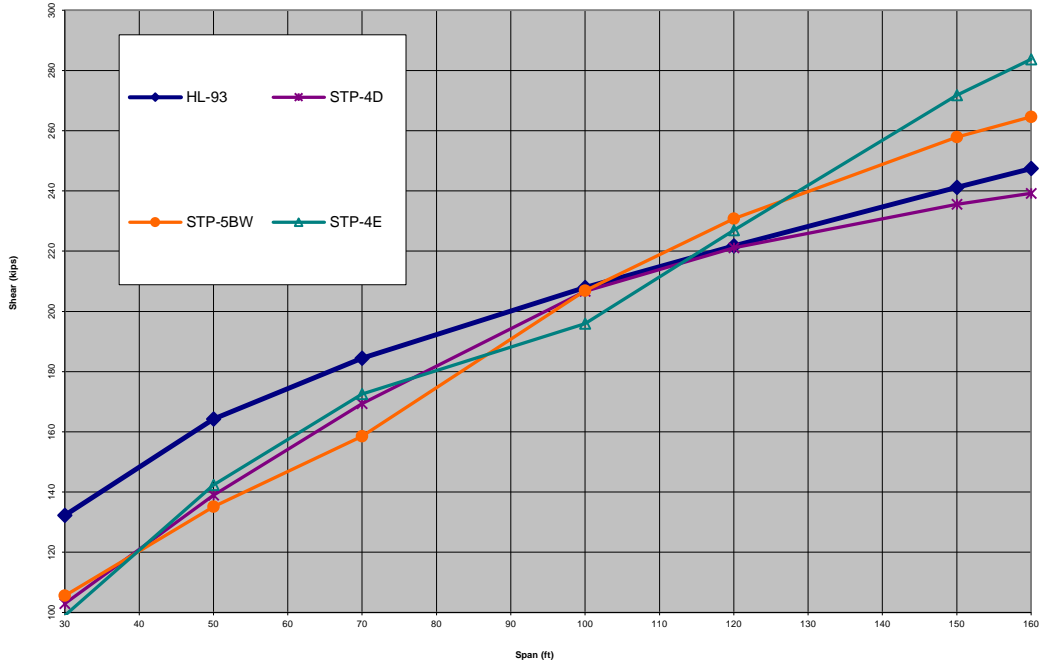

Figure 1.3.2D

Live Load + Impact for Single-Span Prismatic Members
Maximum Shear - Strength Limit State

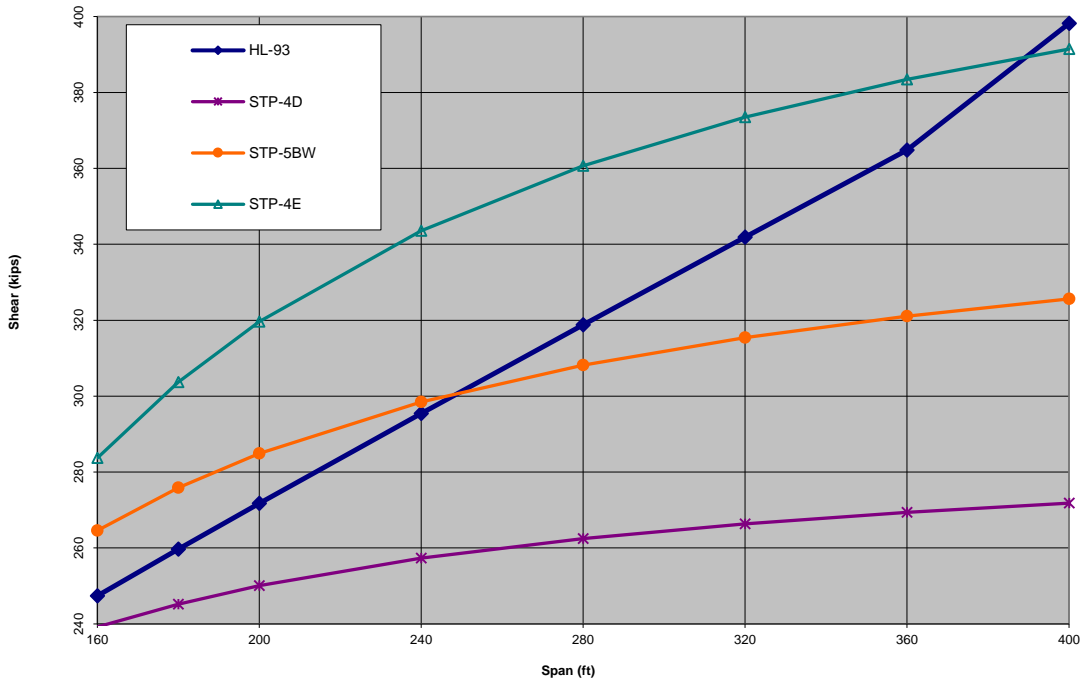

Figure 1.3.2E

Bridge Design Manual – June 2020
Oregon Department of Transportation
Section 1 – Design Standards

- (2) Pedestrian Structures – For bridges designed for only pedestrian and/or bicycle traffic, use a live load of 90 psf. If an Agency design vehicle is not specified, use AASHTO Standard H-5 or H-10 Truck loading as shown in *Figure 1.3.2F* below to check the longitudinal beams. A vehicle impact allowance is not required. For a pedestrian and/or bikeway bridge clear deck width less than 7' do not consider the maintenance truck. See also the AASHTO “*LRFD Guide Specifications for the Design of Pedestrian Bridges*”.

Clear deck width 7' to 10' 10,000 lb. (H5 Truck)
Clear deck width over 10' 20,000 lb. (H10 Truck)

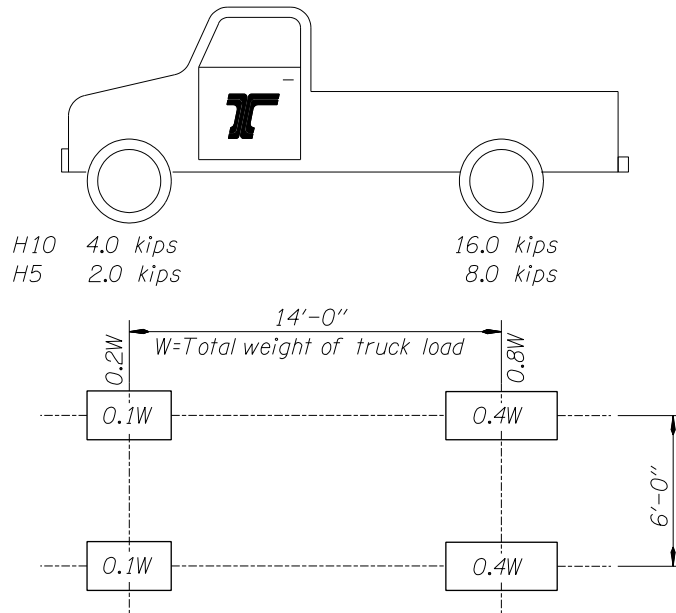

Figure 1.3.2F

- (3) Widening of Vehicular Traffic Structures – When widening an existing structure, the widening will generally be designed using the loading given in *BDM 1.3.2(1)*. Designs using a lesser design live load will require a design deviation from the State Bridge Engineer. Live loading will never be less than the design live load for the existing structure.
- (4) Structure Repair and/or Strengthening – When repairing or strengthening an existing structure it is not necessary to meet the loading given in *BDM 1.3.2(1)*. Design repair or strengthening projects for the maximum load effect from the following permit trucks using the AASHTO LRFD Bridge Design Specifications Strength II Limit State (see *Figure 1.3.2A* for vehicle descriptions and *LRFD Table 3.4.1-1* for Load Factors):

- ODOT OR-STP-4D
- ODOT OR-STP-5BW
- ODOT OR-STP-4E

(5) Distribution Factors

New, Replacement, & Strengthening Bridge Designs: Use the live load distribution factors and procedures provided in the AASHTO LRFD Bridge Design Specifications to determine load effects on bridge members. Higher level techniques such as finite element analysis or grillage analysis will not be accepted as a basis for adjustment of AASHTO live load distribution factors in *LRFD 4.6.2.2.2 and 4.6.2.2.3* for design of new bridges.

For complex bridges outside of the range of applicability of *LRFD 4.6.2.2.2 and 4.6.2.2.3*. Submit design deviation according to *BDM 1.2.2* and supported with the following information to use refined method of analysis per *LRFD 4.6.3*:

- Name, version, and release date of design software used to perform refined method of analysis.
- Proposed table of live load distribution factors for controlling moment and shear at critical locations in each span to aid in permit issuance and load rating of the bridge for all standard load rating trucks listed in ODOT LRFR Manual Section 1.5 and report rating factors using ODOT LRFR Section 11 Load Rating Summary Workbook (excel).
- Apply an addition 1.10 factor to the Strength I Load Combination obtained from the refined method of analysis.
- Provide a comparison of the moment and shear (to be included in the calculation book) for an equivalent single girder line with AASHTO Distribution Factors vs refined method of analysis (with lower distribution factors and lower demands) for both the live load and dead load.

For single-span bridges with prismatic girders, *Figures 1.3.2B to 1.3.2E* are provided to help determine the controlling permit truck for various span lengths.

For repair and/or strengthening of prestressed concrete structures, ensure the requirements of Service I and III Limit States are satisfied using HL-93 loading.

See *BDM 1.30* for additional criteria for strengthening bridges.

Bridge Load Ratings: Use live load distribution factors provided in the AASHTO LRFD Bridge Design Specifications to make the initial analysis. However, if the load rating is not acceptable, a higher level technique such as finite element analysis or grillage analysis may be considered. Using a higher level technique is acceptable for load rating because we are analyzing the loading conditions on an existing bridge and trying to avoid needlessly spending money to strengthen a bridge or post a bridge that may not need it.

See the ODOT Load Rating Manual for further guidance.

1.3.3 Sidewalk Loading

For sidewalks not separated from traffic by a structural rail, account for the potential for a truck to mount the sidewalk. Design the sidewalk for the greater of:

- 0.075 ksf pedestrian loads considered simultaneously with the vehicular load in the adjacent lane as stated in *BDM 3.6.1.6* of the LRFD Bridge Design Specifications. Per *LRFD 3.6.2.1*, impact does not apply to pedestrian loads.
- The LRFD design truck placed with a line of wheels 2.0 feet from the face of rail. Do not apply a lane load with the design truck, but do include impact. Consider this load only under the Strength I limit state. Do not consider trucks or vehicle loads in adjacent lanes. Do apply the multiple-presence factor (m) for this case.

In addition to the above cases, ensure the supporting member (exterior girder) is adequate for HL-93 loading when the sidewalk is removed and a standard concrete barrier (per BR200) is placed at the edge of deck.

1.3.4 Vehicular Collision Forces: CT

Modify *LRFD 3.6.5* as follows:

Where the design choice is to redirect or absorb the collision load, use pier systems with three or more columns and protection shall consist of a minimum 42 inch high MASH crash tested rigid TL-5 barrier with standard pin anchorage to subgrade. Use minimum column sizes as follows:

a. For barriers 0-3.25 feet clear distance from the face of the pier component to the traffic face of the barrier, use a minimum 48" circular (or equivalent square) column with 1-1/8 % minimum longitudinal steel reinforcement and #4 spiral reinforcement with 4 inch pitch.

b. For barriers 3.25 feet or greater clear distance from the face of the pier component to the traffic face of the barrier, use a minimum 36" circular (or equivalent square) column with 1-1/8 % minimum longitudinal reinforcement and #4 spiral reinforcement with 4 inch pitch.

Earth Mounds are no longer an acceptable method of column protection. At this time, however, existing earth mounds do not need to be removed.

Commentary:

The standard detail for barrier protection of a structure (column, wall, traffic support pole, or other structure) places the curb face of the barrier 4'-0" minimum from the face of the structure. This detail dates back at least as far as the mid 1990's. The 4 feet dimension is intended to allow room for "rollover" when a truck impacts the barrier. It should be noted that barrier impacts can create a rollover scenario that exceeds 4 feet. Therefore, offsets exceeding 4 feet should be considered when it can be provided without impacting roadway width standards. AASHTO 9th Edition has updated this spacing to 3.25 feet to match current research.

If 4 feet or more offset can be provided, the proposed barrier placement detail will meet standards and no special consultation with the roadway designer is necessary. It should be understood that such a detail may pose some risk of structure impact, even if small.

Where the 4 feet offset cannot be achieved, consultation with the roadway designer is needed to confirm what offset can be provided. It should be noted that any offset less than 4 feet results in additional risk for catastrophic impact of the structure being protected. Therefore, consideration of reducing roadway shoulder width should be considered. The result should be to find an acceptable balance between roadway risk (due to inadequate shoulder width) and structure risk (of impact to the structure being protected).

When evaluating the roadway and structure risk, the following factors should be taken into account:

- *Alignment of the roadway – straight vs. curved, inside of curve vs. outside of curve*
- *Length of roadway width reduction (example, single sign support vs. long retaining wall)*
- *Ability of the structure to absorb a hit (single column vs. wall abutment)*
- *Traffic volume – Higher traffic volume means higher risk of an incident*
- *Consequences of structure failure*

When offset must be minimized, a detail with 3 inch offset from the back of pinned barrier to the face of the structure is provided. Understand that use of this detail includes accepting significant risk! The 3 inch minimum offset is intended to minimize the amount of horizontal impact load that would be transferred from the impacted barrier to the structure being protected. The void between the back of the barrier is typically filled with pea gravel. Note that 3 inch concrete surfacing is often provided at the top of barrier for aesthetic purposes. This surfacing is expected to disintegrate upon impact and so would not be expected to transit unacceptable forces to the structure being protected.

In cases where reduction of the offset width provides an unacceptable risk against rollover, the barrier can be transitioned from a safety shape to vertical. Vertical barrier will reduce vehicle rollover and in some cases can provide an installation with an acceptable level of risk.

Intrusions zones for TL3 and TL4 barrier per Guidelines for Attachments to Bridge Rails and Median Barriers Midwest Roadside Safety Facility (MwRSF); University of Nebraska-Lincoln, Nebraska, 2003 are shown below.

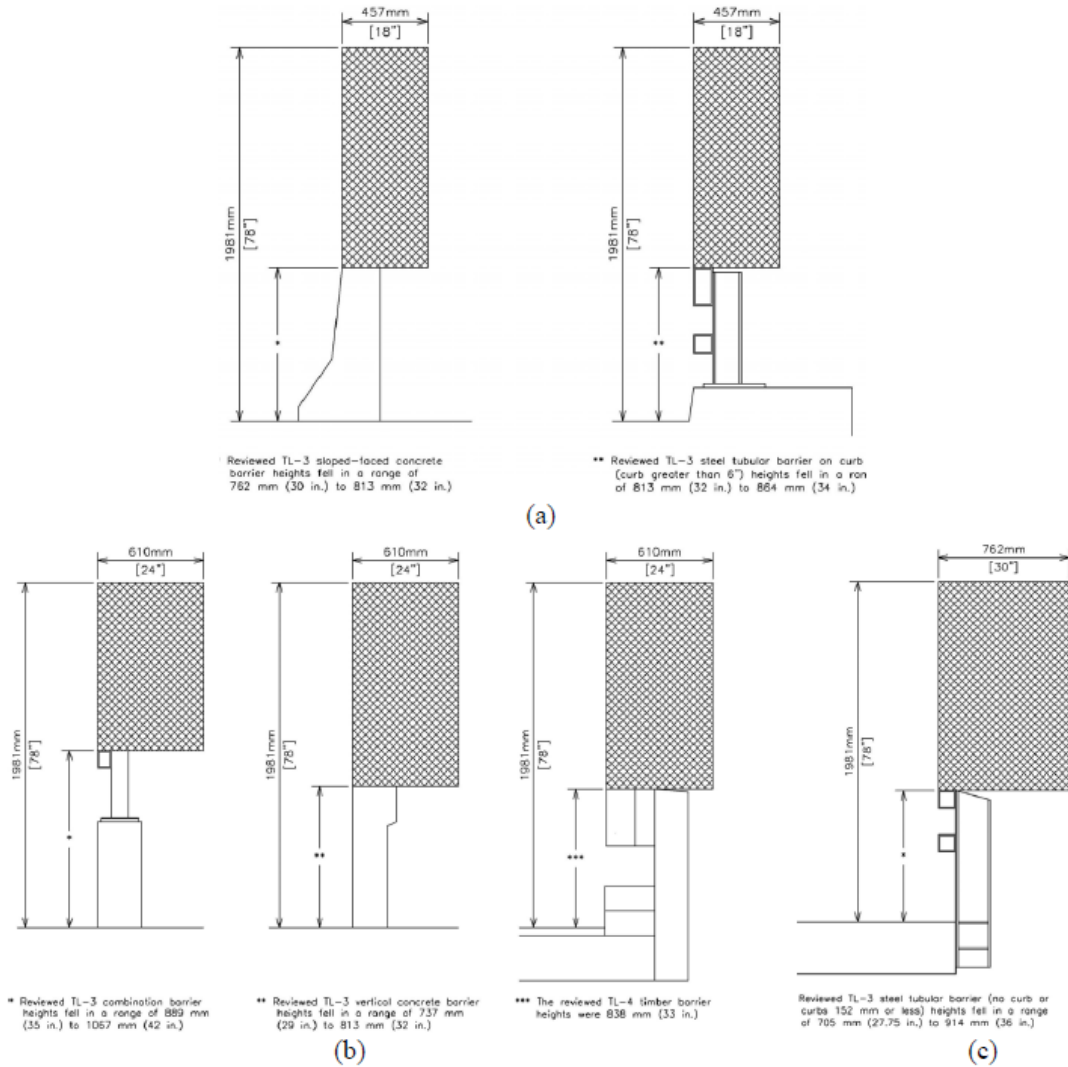

**Figure 2.1. TL-3 Zone of Intrusions for
 (a) Sloped Face Concrete Barrier and Steel Tube Rail on Curbs > 6 inches;
 (b) Vertical Face Concrete Barrier and Combination Concrete and Steel Rail;
 and (c) Steel Tube Rail on Curbs > 6 inches (3).**

Bridge Design Manual – June 2020
Oregon Department of Transportation
Section 1 – Design Standards

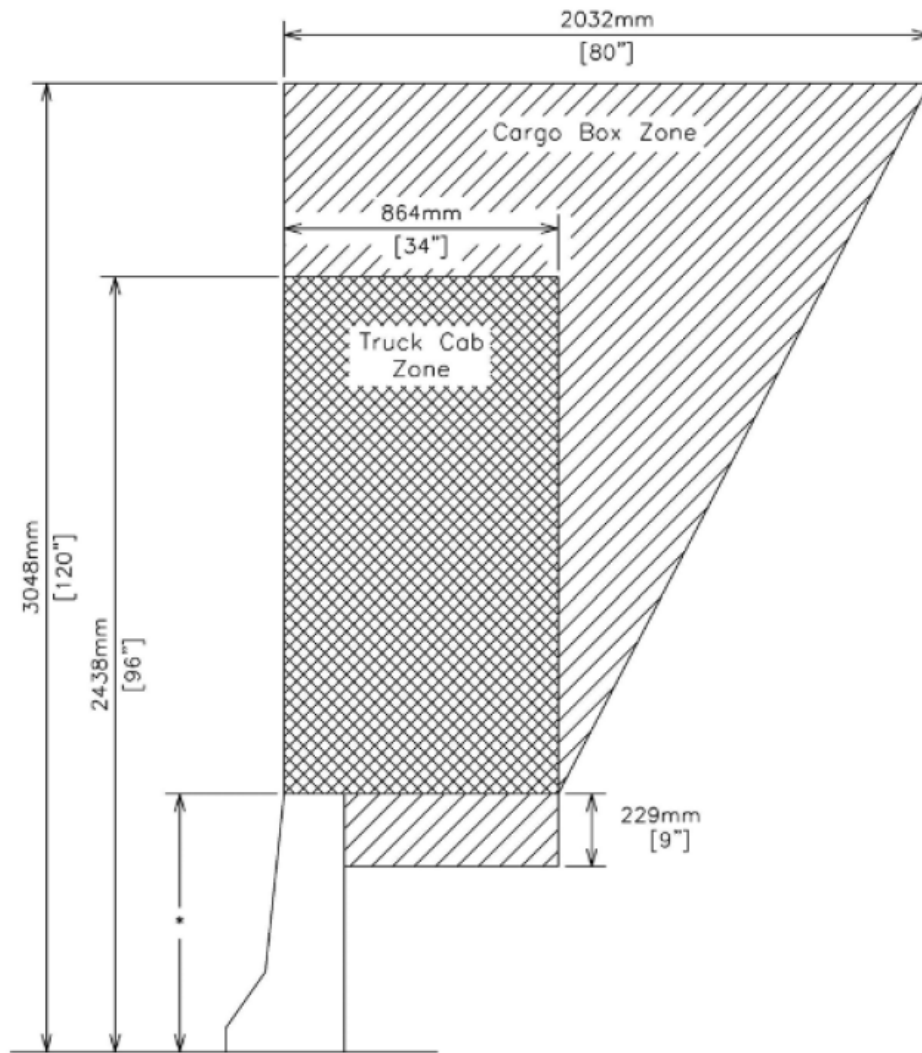

* Reviewed TL-4 barrier heights fell in a range of 737 mm (29 in.) to 1067 mm (42 in.)

1.3.5 Change in Foundations Due to Limit State for Scour

In lieu of *LRFD 2.6.4.4.2* bullet two and *LRFD 3.7.5*, apply the Extreme Limit States in accordance with *LRFD 3.4.1* and only include the anticipated scour depth due to channel degradation in Extreme Event I Limit State. Note *LRFD 2.6.4.4.2* bullet one still apply. Obtain estimates of channel degradation from the Hydraulic Designer.

1.3.6 Thermal Forces

Use the following temperature ranges:

		<u>Metal Structures</u>	<u>Concrete Structures</u>
Section I	Mild Climate	+10 ⁰ F. to +110 ⁰ F.	+22 ⁰ F. to +72 ⁰ F.
Section II	Moderate Climate	-10 ⁰ F. to +120 ⁰ F.	+12 ⁰ F. to +82 ⁰ F.
Section III	Rigorous Climate	-30 ⁰ F. to +120 ⁰ F.	0 ⁰ F. to +82 ⁰ F.

Section I designates that portion of the state west of the Coast Range, Section II the valley region between the Coast Range and Cascade Mountains, and Section III the Cascade Mountains and all of eastern Oregon. For structures in the Columbia River Gorge, use Section III.

Figure the rise and fall in temperature from an assumed temperature at time of erection. The annual mean temperature for Sections I and II is 52 degree F. and for Section III is 47 degree F.

1.3.7 Wind Load

Determine wind load according to *LRFD 3.8.1*. Determine the design 3-second gust wind speed used in the determination of design wind loads on bridges and walls from the figure shown in standard drawing [TM672](#) LRFD Ultimate Design Wind Speed Map. The wind velocity map is adapted from *AASHTO LRFD Bridge Design Specifications* and uses the wind speed maps shown in the 2014 Oregon Structural Code to account for locations in the State with special wind regions.

1.4 STRUCTURAL ANALYSIS

[1.4.1 Ductility, Redundancy and Operational Importance](#)

[1.4.2 Shear Correction Factor for Skewed Girders](#)

[1.4.1 Ductility, Redundancy and Operational Importance \(LRFD 1.3.3, 1.3.4 & 1.3.5\)](#)

LRFD 1 provides three adjustment factors; η_D for ductility, η_R for redundancy and η_I for operational importance. Apply the ductility and redundancy factors per LRFD without change. Submit a deviation to the State Bridge Engineer before using a redundancy factor < 1.0. For the operational importance factor, consider all bridges as “typical” ($\eta_I = 1.0$).

[1.4.2 Shear Correction Factor for Skewed Girders](#)

Apply a live load shear correction factor according to *LRFD Table 4.6.2.2.3c-1* to the critical shear section near the support for exterior longitudinal beam (girder) members that are on skewed bents. Vary the correction factor along the length of the girder linearly from full value at the critical shear section to zero at midspan.

For interior girders, apply a portion of the exterior girder correction factor (CF_{ext}) as follows:

- Side-by-side slabs or boxes $CF_{int} = 1 + 0.5 * (CF_{ext} - 1)$
- Girder bridges and spread slabs or boxes $CF_{int} = 1 + 0.25 * (CF_{ext} - 1)$

The shear correction factor is intended to protect against increased loading at obtuse corners. Therefore, the additional shear capacity is really only needed at the obtuse corners. However, for simplicity of construction it is recommended that the both obtuse and acute girder ends be detailed the same.

Where additional steel to meet the shear correction factor loading is minor, consider whether or not it is economical to detail interior girders the same as exterior girders. This may often be the case for precast, prestressed concrete members.

Standard drawings for precast, prestressed members assume each member will have the same shear details at each end of the bridge. For simplicity of construction it is recommended that both ends be detailed the same. In the rare case when ends are not detailed the same, add contract provisions to ensure the intended bent location for each girder end is clearly marked on the girder before the girder is transported to the job site.

1.5 CONCRETE

[1.5.1 Concrete, General](#)

[1.5.2 Concrete Finish](#)

[1.5.3 Concrete Bonding Agents](#)

[1.5.4 Curing Concrete](#)

[1.5.5 Reinforcement](#)

[1.5.6 Precast Prestressed Concrete Elements](#)

[1.5.7 Cast-In-Place Superstructure](#)

[1.5.8 Post-Tensioned Structures](#)

[1.5.9 Camber Diagrams](#)

[1.5.10 Pour Schedules](#)

1.5.1 Concrete, General

Designate the concrete class by the minimum compressive strength at 28 days followed by the maximum aggregate size (e.g., Class 4000 – 3/4). Unless otherwise specified, Class 3300 – 1-1/2, 1 or 3/4 is called for by the Standard Specifications. The maximum ultimate strength on which allowable stresses are based is 5000 psi, except for prestressed concrete. Use High Performance Concrete (HPC) in all cast-in-place concrete decks and end panels, with the exception of pedestrian bridge decks. Pedestrian bridge decks do not require HPC unless they are at a location using significant amounts of deicing chemicals.

Classes of Concrete

(For design and to be shown on plans)

HPC4500 – 1-1/2	All poured decks [except Box Girder decks that require greater strength and Pedestrian Bridge decks]
	Note: This concrete strength works well with both Grade 80 and Grade 60 rebar and therefore would facilitate use of Grade 80 rebar, but still allow Contractors to consider Grade 60 rebar without the need to change to a different concrete mix. The use of more coarse aggregate is to achieve more durable decks.
HPC4500 – 1-1/2	End Panels
4000 – 3/8	Drilled Shafts
XXXX – 3/4	Prestressed members [Does not include poured deck on prestressed members, see above]
XXXX – 1/2 or 3/8	Post-tensioned box girder bottom slab and stem walls
XXXX – 3/4	Compression Members
3300 – 1-1/2, 1, or 3/4	All other concrete

Use internally cured concrete for bridge deck when shrinkage cracking is a concern. Internal curing (IC) is a practical way of supplying additional curing water throughout the concrete mixture. This water can improve the hydration of cement, reduce autogenous shrinkage, and improve durability. Use of IC with lightweight fine aggregate for concrete is allowed to mitigate cracking due to shrinkage in bridge decks.

ODOT implemented internally cured concrete on a few projects in recent years. Due to its fairly new application, contact ODOT Bridge Engineering Section and Structure Services prior to selecting internal curing. Internally cured concrete utilizes lightweight fine aggregate (LWFA) according to ASTM C1761. The availability of lightweight fine aggregates (expanded clay or shale) depends on the local suppliers.

By replacing normal weight fine aggregate with lightweight fine aggregate for IC, the unit weight of the concrete is lighter. For concrete having an equilibrium density less than 0.135 kcf, the concrete can be considered lightweight concrete. When using lightweight concrete, adjust reinforcement development length for lightweight concrete per *LRFD 5.10.8.2. SP02001* is required when internally cured concrete is specified. Curing time before subsequent loading may be shortened.

1.5.2 Concrete Finish

Concrete finishes are defined in *SP 00540.53* of the *Oregon Standard Specifications for Construction*. The usual finishes are General Surface Finish and Class 1 Surface Finish. Occasionally, Class 2 Surface Finish is used as mentioned in the following paragraph.

Generally, concrete finishes are selected as follows:

- For bridges whose superstructure and substructure can be viewed by the public, such as grade separations and river crossings in or near populated areas, exposed surfaces receive a Class 1 Surface Finish. In special situations of high visibility to traffic or people, use of a Class 2 Surface Finish may be considered. Normally, it is limited to the concrete rail sides facing the roadway/bikeway and the tops.
- For bridges not viewed by large segments of the public, such as stream crossings in sparsely populated areas, exposed surfaces, except portions of the concrete bridge rail, receive a General Surface Finish. The concrete rail sides facing the roadway/bikeway and tops receive a Class 1 Surface Finish.

Review your selected surface finish with your Design Team.

Pedestrian concrete bridge decks do not require Deck Roadway Texturing with saw cutting according to *SP 00540.50(c)*. Instead apply a Deck Sidewalk Finish according to *SP 00540.50(d)*.

Do not use color additives in concrete mixes. Provide color to concrete only by coating with either concrete stain or concrete paint products from the QPL.

Include details similar to *Figures 1.5.2A, 1.5.2B, or 1.5.2C* for all contract plans:

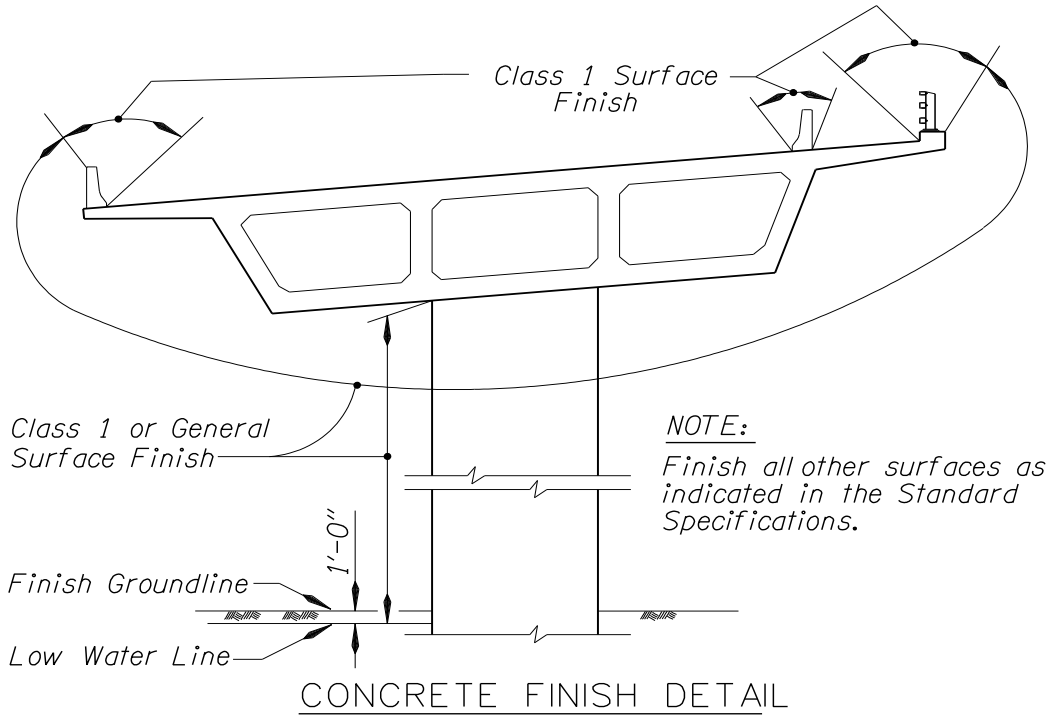

Figure 1.5.2A

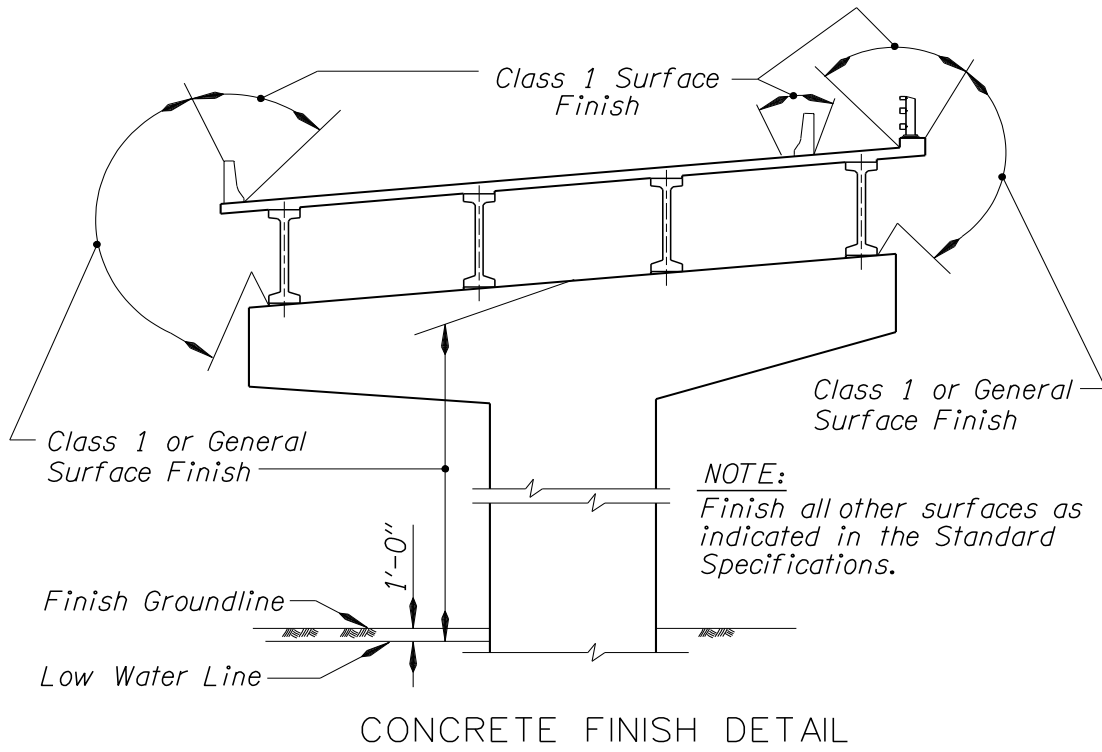

Figure 1.5.2B

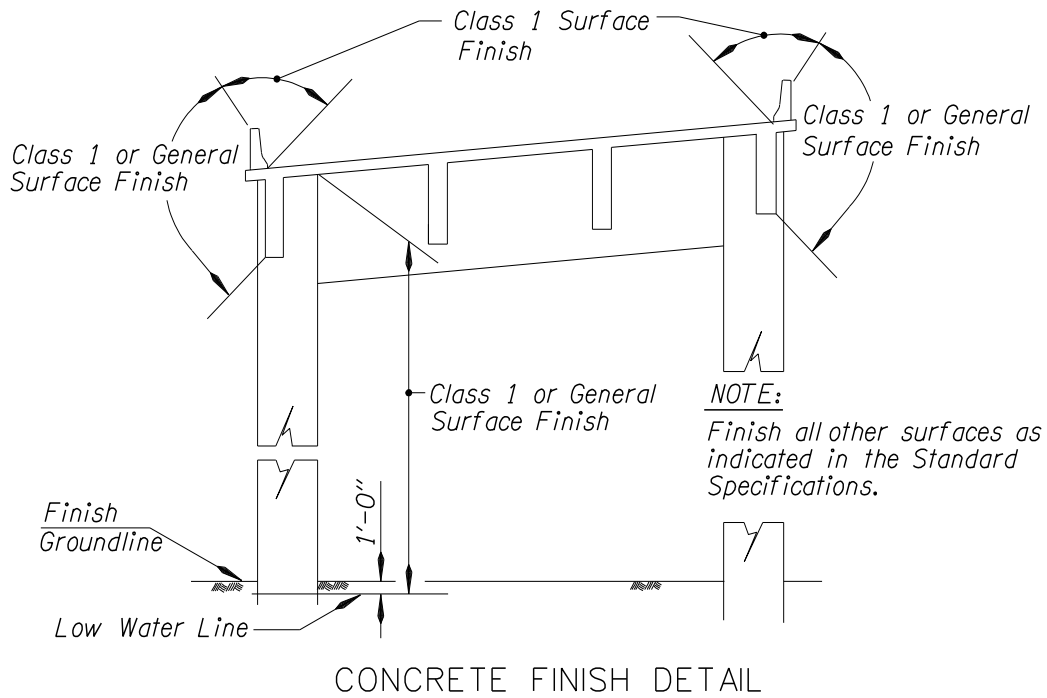

Figure 1.5.2C

1.5.3 Concrete Bonding Agents

Bonding agents are used to help new concrete adhere to existing concrete. To obtain better bond with agents the existing surface must be clean, dry and at proper temperature. The surfaces must also be well exposed to facilitate brush application of the bonding agent. Two principal bonding agents are in use today:

- Epoxy - These agents provide the best bond when properly applied. However, they are highly volatile and if the agent is allowed to dry before placement of the new concrete, a bond breaker may be formed. For this reason restrict the use of epoxy agents to critical situations where control can be guaranteed.
- Concrete - These agents have longer pot life and improved bond. They may be applied with greater lead time, but have the same application requirements as epoxy agents.

At normal construction joints, a bonding agent is not generally needed. Mating surfaces prepared to the specifications are considered sufficient to provide acceptable bond and shear transfer through the roughened surface and rebar holding a tight joint.

1.5.4 Curing Concrete

SP 00540.51 in the standard specifications require cast-in-place concrete to be cured with water. Design all structures assuming concrete is cured using the ODOT standard. Acting as EOR, assure that alternate curing methods are not allowed without prior approval of the ODOT Structure Materials Engineer.

Bridge Decks must also be cured with water. Although ODOT does use curing compounds for some pavement and sidewalk applications, curing compounds are not be allowed on bridge decks. ODOT experimented with curing compounds in the early 1990's. The results were not consistent from batch to batch.

Also, more recent experiments with curing compounds revealed that cylinders cured with a curing compound achieved only 80 percent compressive strength compared to water cured cylinders.

The ODOT water cure requirement also applies to bridge columns, abutments and retaining walls. Since it is difficult to keep vertical surfaces saturated during the cure period, vertical forms must often be left in place for the entire cure period. Contractors will often request to use a curing compound so that forms can be stripped sooner and production increased. However, due to the negative impacts of curing compounds, their use is rarely permitted.

For applications that receive a coating, use of curing compounds can inhibit adherence of the coating. Generally, curing compounds must be removed by sandblasting before subsequent coatings can be applied. Removal of a curing compound would be even more problematic on textured surfaces.

In summary, do not use curing compounds. Exceptions require approval from the ODOT Structure Materials Engineer, but do not require a design deviation from Bridge Section.

1.5.5 Reinforcement

1.5.5.1 Reinforcement, General

Make sure there is enough room for bars to fit and to place concrete. Be sure steel can be placed and supported. Show bolster bars on reinforcement details when needed.

1.5.5.1.1 Standard Bar Chart

Bar #	Nominal Dia. (in)	Area (in ²)	Weight (lb/ft)
3	0.375	0.11	0.376
4	0.500	0.20	0.668
5	0.625	0.31	1.043
6	0.750	0.44	1.502
7	0.875	0.60	2.044
8	1.000	0.79	2.670
9	1.128	1.00	3.400
10	1.270	1.27	4.303
11	1.410	1.56	5.313
14	1.693	2.25	7.650
18	2.257	4.00	13.60

Figure 1.5.5.1.1

1.5.5.1.2 Minimum Bar Covering

Provide a minimum 2 inch covering measured from the surface of the concrete to the face of any uncoated or coated reinforcing bar except as follows:

Location:	Cover (in)
Top of deck slab (main reinforcing)*	2.5
Bottom of deck slab*	1.5
Stirrups and ties in T-beams, bottom rebar of slab spans, and curbs and rails*	1.5
Stirrups in box girder stems with non-bundled ducts **	2.5
Stirrup ties in box girder stems with non-bundled ducts **	2
Bottom slab steel in box girders	1
All faces in precast members (slabs, box beams and girders)	1
Pier and column spirals, hoops or tie bars+ (increase to 4" if exposed to marine environment or concrete is deposited in water)	2.5
Footing mats for dry land foundations (use 6" if ground water may be a construction problem)	3
Footing mats for stream crossing foundations	6

*Use 2 inches minimum cover for all surfaces exposed to the effects of a marine environment, *BDM 1.26*.

**For box girder stems with bundled ducts, provide 3 inches clearance to ducts and place stirrups directly against ducts.

+Cover over supplementary crossties may be reduced by the diameter of the tie.

Figure 1.5.5.1.2

1.5.5.1.3 Reinforcement for Shrinkage and Temperature

Provide reinforcement for shrinkage and temperature stresses near exposed surfaces and in structural mass concrete according to *LRFD 5.10.8*. Use an area of reinforcement per surface of at least 0.0008 times the gross concrete area with a minimum of #4 at 18 inch centers. Space the reinforcement no farther apart than three times the concrete thickness or a maximum of 18 inch centers.

Thickness (in)	A_s (in ² /ft)	MAXIMUM BAR SIZE AND SPACING FOR ONE SURFACE (inches)			
6	0.062	#4 @ 18			
9	0.091	#4 @ 18			
12	0.118	#4 @ 18			
15	0.144	#4 @ 15			
18	0.170	#4 @ 12			
21	0.194	#4 @ 12	#5 @ 18		
24	0.217	#4 @ 10	#5 @ 15		
27	0.239	#4 @ 10	#5 @ 15		
30	0.260		#5 @ 12	#6 @ 18	
36	0.300		#5 @ 12	#6 @ 15	
48	0.371		#5 @ 10	#6 @ 12	#7 @ 18
60	0.433			#6 @ 12	#7 @ 15

Figure 1.5.5.1.3

Since the amount of reinforcement is somewhat empirical, convenient spacing can be assumed as shown in the above table. The table is intended for preliminary purposes only. It is based on a least width dimension of 10 feet.

1.5.5.1.4 Spacing of Shear Reinforcement

Where shear reinforcement is required and placed perpendicular to the axis of the member, spacing is not to exceed 18 inches.

1.5.5.1.5 Negative Moment Reinforcement

For cantilever crossbeams with wide bents, extend at least one-half of the negative reinforcement the full length of the crossbeam.

1.5.5.1.6 Minimum Bar Spacing

Bar #	Nominal Dia.(d _b) (in)	2.5 x d _b or 1.5"+d _b (in)	(1.5x1.5) + d _b for 1.5" agg. (in)	(1.5x0.75)+ d _b for 0.75" agg. (in)
3	0.375	1-7/8	2-5/8	1-1/2
4	0.500	2	2-3/4	1-5/8
5	0.625	2-1/8	2-7/8	1-3/4
6	0.750	2-1/4	3	1-7/8
7	0.875	2-3/8	3-1/8	2
8	1.000	2-1/2	3-1/4	2-1/8
9	1.128	2-7/8	3-3/8	2-1/4
10	1.270	3-1/4	3-1/2	2-3/8
11	1.410	3-5/8	3-5/8	2-1/2
14	1.696	4-1/4	4	2-7/8
18	2.257	5-5/8	4-1/2	3-3/8

Figure 1.5.5.1.6

1.5.5.1.7 *Modified Tension Development Length - GRADE 60 – Uncoated Deformed Bars

Provide details to achieve $\lambda_{rc} = 0.4$ reference to *LRFD 5.11.2.1*. The following modified tension development length is calculated using λ_{rc} , reinforcement confinement factor, equal to 0.4.

Bar #	L _d (in) f'c =3.3 ksi	L _d (in) f'c =4.0 ksi	L _d (in) f'c =4.5 ksi	L _d (in) f'c =5.0 ksi	L _d (in) f'c =6.0 ksi
3	15.46	14.04	13.24	12.56	12.00
4	20.61	18.72	17.65	16.74	15.28
5	25.76	23.40	22.06	20.93	19.11
6	30.92	28.08	26.47	25.12	22.93
7	36.07	32.76	30.89	29.30	26.75
8	41.22	37.44	35.30	33.49	30.57
9	46.50	42.23	39.82	37.77	34.48
10	52.35	47.55	44.83	42.53	38.82
11	58.12	52.79	49.77	47.22	43.10
14	69.79	63.39	59.76	56.69	51.75
18	93.03	84.50	79.67	75.58	69.00

* Top bars are horizontal bars placed so that more than 12" of fresh concrete is cast below the reinforcement.

Bar #	L _d (in) f'c =3.3 ksi	L _d (in) f'c =4.0 ksi	L _d (in) f'c =4.5 ksi	L _d (in) f'c =5.0 ksi	L _d (in) f'c =6.0 ksi
3	12.00	12.00	12.00	12.00	12.00
4	15.85	14.40	13.58	12.88	12.00
5	19.82	18.00	16.97	16.10	14.70
6	23.78	21.60	20.36	19.32	17.64
7	27.74	25.20	23.76	22.54	20.58
8	31.71	28.80	27.15	25.76	23.52
9	35.77	32.49	30.63	29.06	26.53
10	40.27	36.58	34.48	32.71	29.86
11	44.71	40.61	38.29	36.32	33.16
14	53.68	48.76	45.97	43.61	39.81
18	71.56	65.00	61.28	58.14	53.07

* Other horizontal bars.

1.5.5.1.8 *Modified Tension Development Length - GRADE 60 – Epoxy Coated Deformed Bars

Provide details to achieve $\lambda_{rc} = 0.4$ reference to *LRFD 5.11.2.1*. The following modified tension development length is calculated using λ_{rc} , reinforcement confinement factor, equal to 0.4.

Bar #	L_d (in) f'c =3.3 ksi	L_d (in) f'c =4.0 ksi	L_d (in) f'c =4.5 ksi	L_d (in) f'c =5.0 ksi	L_d (in) f'c =6.0 ksi
3	20.21	18.36	17.31	16.42	14.99
4	26.95	24.48	23.08	21.90	19.99
5	33.69	30.60	28.85	27.37	24.98
6	40.43	36.72	34.62	32.84	29.98
7	47.17	42.84	40.39	38.32	34.98
8	53.90	48.96	46.16	43.79	39.98
9	60.80	55.23	52.07	49.40	45.09
10	68.46	62.18	58.62	55.61	50.77
11	76.00	69.03	65.09	61.75	56.37
14	91.26	82.89	78.15	74.14	67.68
18	121.66	110.50	104.18	98.84	90.23

* Top bars are horizontal bars placed so that more than 12" of fresh concrete is cast below the reinforcement.

* Cover less than $3d_b$ or clear spacing between bars less than $6d_b$.

Bar #	L_d (in) f'c =3.3 ksi	L_d (in) f'c =4.0 ksi	L_d (in) f'c =4.5 ksi	L_d (in) f'c =5.0 ksi	L_d (in) f'c =6.0 ksi
3	17.84	16.20	15.27	14.49	13.23
4	23.78	21.60	20.36	19.32	17.64
5	29.73	27.00	25.46	24.15	22.05
6	35.67	32.40	30.55	28.98	26.45
7	41.62	37.80	35.64	33.81	30.86
8	47.56	43.20	40.73	38.64	35.27
9	53.65	48.73	45.94	43.59	39.79
10	60.40	54.86	51.73	49.07	44.80
11	67.06	60.91	57.43	54.48	49.73
14	80.52	73.14	68.95	65.42	59.72
18	107.35	97.50	91.93	87.21	79.61

* Other horizontal bars.

* Cover less than $3d_b$ or clear spacing between bars less than $6d_b$.

Bridge Design Manual – June 2020
Oregon Department of Transportation
Section 1 – Design Standards

Bar #	L_d (in) $f'c = 3.3$ ksi	L_d (in) $f'c = 4.0$ ksi	L_d (in) $f'c = 4.5$ ksi	L_d (in) $f'c = 5.0$ ksi	L_d (in) $f'c = 6.0$ ksi
3	18.55	16.85	15.88	15.07	13.76
4	24.73	22.46	21.18	20.09	18.34
5	30.92	28.08	26.47	25.12	22.93
6	37.10	33.70	31.77	30.14	27.51
7	43.28	39.31	37.06	35.16	32.10
8	49.46	44.93	42.36	40.18	36.68
9	55.80	50.68	47.78	45.33	41.38
10	62.82	57.06	53.80	51.03	46.59
11	69.74	63.35	59.73	56.66	51.72
14	83.74	76.06	71.71	68.03	62.11
18	111.64	101.40	95.60	90.70	82.79

* Top bars are horizontal bars placed so that more than 12" of fresh concrete is cast below the reinforcement.

* Cover not less than $3d_b$ and clear spacing between bars not less than $6d_b$.

Bar #	L_d (in) $f'c = 3.3$ ksi	L_d (in) $f'c = 4.0$ ksi	L_d (in) $f'c = 4.5$ ksi	L_d (in) $f'c = 5.0$ ksi	L_d (in) $f'c = 6.0$ ksi
3	14.27	12.96	12.22	12.00	12.00
4	19.02	17.28	16.29	15.46	14.11
5	23.78	21.60	20.36	19.32	17.64
6	28.54	25.92	24.44	23.18	21.16
7	33.29	30.24	28.51	27.05	24.69
8	38.05	34.56	32.58	30.91	28.22
9	42.92	38.98	36.75	34.87	31.83
10	48.32	43.89	41.38	39.26	35.84
11	53.65	48.73	45.94	43.59	39.79
14	64.42	58.51	55.16	52.33	47.77
18	85.88	78.00	73.54	69.77	63.69

* Other horizontal bars.

* Cover not less than $3d_b$ and clear spacing between bars not less than $6d_b$.

1.5.5.1.9 *Class B Tension Lap Splice (in) - GRADE 60 – Uncoated Deformed Bars

Provide details to achieve $\lambda_{rc} = 0.4$ reference to *LRFD 5.11.2.1*. The following modified tension development length is calculated using λ_{rc} , reinforcement confinement factor, equal to 0.4.

Bar #	L_d (in) $f'c = 3.3$ ksi	L_d (in) $f'c = 4.0$ ksi	L_d (in) $f'c = 4.5$ ksi	L_d (in) $f'c = 5.0$ ksi	L_d (in) $f'c = 6.0$ ksi
3	20.09	18.25	17.21	16.33	15.60
4	26.79	24.34	22.94	21.77	19.87
5	33.49	30.42	28.68	27.21	24.84
6	40.19	36.50	34.42	32.65	29.81
7	46.89	42.59	40.15	38.09	34.77
8	53.59	48.67	45.89	43.53	39.74
9	60.45	54.90	51.76	49.11	44.83
10	68.05	61.81	58.28	55.29	50.47
11	75.56	68.63	64.70	61.38	56.03

* Top bars are horizontal bars placed so that more than 12" of fresh concrete is cast below the reinforcement.

Bridge Design Manual – June 2020
Oregon Department of Transportation
Section 1 – Design Standards

Bar #	L_d (in) $f'c = 3.3$ ksi	L_d (in) $f'c = 4.0$ ksi	L_d (in) $f'c = 4.5$ ksi	L_d (in) $f'c = 5.0$ ksi	L_d (in) $f'c = 6.0$ ksi
3	15.46	15.60	15.60	15.60	15.60
4	20.61	18.72	17.65	16.74	15.60
5	25.76	23.40	22.06	20.93	19.11
6	30.92	28.08	26.47	25.12	22.93
7	36.07	32.76	30.89	29.30	26.75
8	41.22	37.44	35.30	33.49	30.57
9	46.50	42.23	39.82	37.77	34.48
10	52.35	47.55	44.83	42.53	38.82
11	58.12	52.79	49.77	47.22	43.10

* Other horizontal bars.

Bridge Design Manual – June 2020
Oregon Department of Transportation
Section 1 – Design Standards

1.5.5.1.10 Minimum Column Bar Lengths in Footings – GRADE 60 Bars & $f'c = 3.3$ ksi

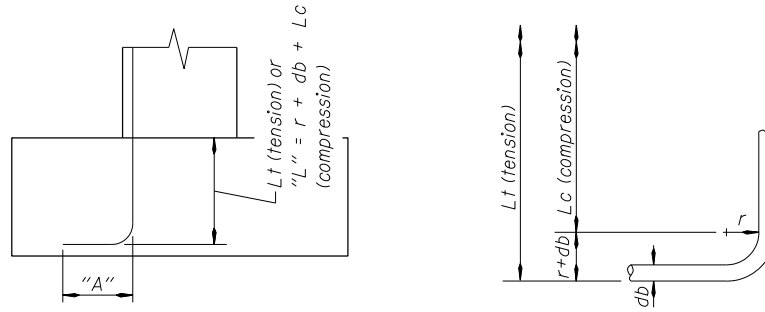

Note:
Increase L_t or L_c 20 percent for epoxy coated bars
"A" and $r + db$ are standard 90° hook dimensions
 L_c is the compression development length
 L_t is the tension development length for standard hooks

COMPRESSION DEVELOPMENT LENGTH - HOOKED BARS						
BASIC COMPRESSION DEVELOPMENT (length for hooked bars $\&dh$)	BAR SIZE	"A"	$r + db$	COMPRESSION "L" * (single bar)	COMPRESSION "L" * (two bar bundle)	COMPRESSION "L" * (three bar bundle)
1'-4"	6	1'-0"	3"	1'-2"	1'-4"	1'-5"
1'-7"	7	1'-2"	3 1/2"	1'-4"	1'-6"	1'-8"
1'-9"	8	1'-4"	4"	1'-6"	1'-9"	1'-10"
2'-0"	9	1'-7"	6"	1'-10"	2'-1"	2'-3"
2'-3"	10	1'-10"	7"	2'-3"	2'-7"	2'-9"
2'-6"	11	2'-0"	7 1/2"	2'-8"	3'-1"	3'-4"
3'-0"	14	2'-7"	11"	3'-10"	4'-5"	4'-10"
3'-11"	18	3'-5"	1'-3"	6'-3"	7'-6"	8'-2"

***Note:**
 $L_c + (r + db)$ and including 0.75 modification factor for reinforcement enclosed within a spiral per LRFD 5.11.2.2.2

TENSION DEVELOPMENT LENGTH HOOKED BARS			
BAR SIZE	"A"	BASIC TENSION DEVELOPMENT (length for hooked bars $\&dh$)	MODIFIED TENSION "L" ** $0.7 \&dh$
6	1'-0"	10"	7"
7	1'-2"	1'-1"	9"
8	1'-4"	1'-5"	1'-0"
9	1'-7"	1'-9"	1'-3"
10	1'-10"	2'-3"	1'-7"
11	2'-0"	2'-9"	1'-11"
14	2'-7"	3'-11"	2'-9"
18	3'-5"	7'-0"	4'-11"

****Note:**
#11 bars and smaller, adequate side and hook extension cover per LRFD 5.11.2.4.2

Figure 1.5.5.1.10

1.5.5.1.11 Welded Splices and Mechanical Connections

When field welding of reinforcing steel is anticipated, use ASTM A706 reinforcing steel. Welding of ASTM A615, Grade 60 reinforcing steel is not permitted without prior approval from the ODOT Welding Engineer.

Welding of ASTM A706 for splices for column spiral reinforcing is permitted.

Use approved mechanical splices for #14 and #18 vertical column bars. Stagger splices as shown below, to avoid adjacent bars being spliced in the same plane.

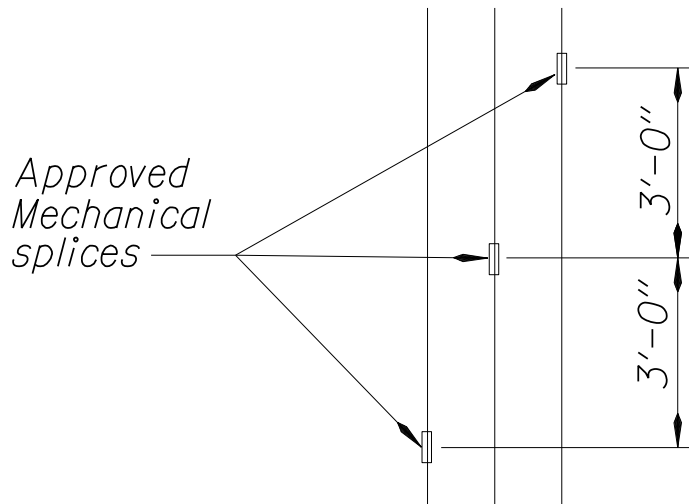

MECHANICAL SPLICE STAGGERING

Figure 1.5.5.1.11

Show lap splices on structure plans with the option of approved mechanical splices available to the contractor.

Special cases such as steel in back walls of abutments of post-tensioned concrete bridges and splicing reinforcement in existing structures may require the use of mechanical splices.

1.5.5.1.12 *Lap Splices – GRADE 60

(Reserved)

1.5.5.1.13 Development of Flexural Reinforcement

The added length, "X", is to provide for unanticipated loading conditions or shifting of the moment diagram due to shear cracking.

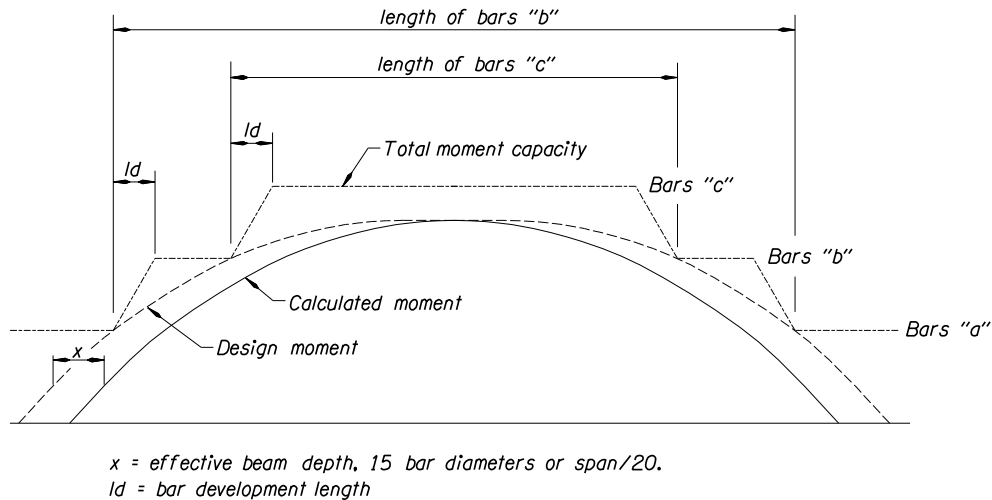

Figure 1.5.5.1.13

1.5.5.1.14 Distribution of Flexural Reinforcement

For moderate exposure conditions, use $\gamma_e = 1.0$. For severe exposure conditions such as structures subject to the effects of sea spray, deicing chemicals or other corrosive environments, use $\gamma_e = 0.75$. In decks, use $\gamma_e = 1.0$.

1.5.5.1.15 Bundled Bars

Tie bundled bars with No. 9, or heavier, wire at 4'-0" maximum centers. Use of bundled #14 or #18 bars requires the approval of the Supervisor.

When bundled bars are used in columns, the minimum clear distance between bundles is 2.5 times the diameter of the largest bar in a bundle.

It is preferred bundled bars not be used in bridge decks. If they are so used, increase the thickness of the deck by the diameter of the bar throughout the length where bundling is used.

1.5.5.1.16 Headed Reinforcement

Headed reinforcement can be used to reduce congestion or reduce development length over a standard hook. Headed reinforcement will always require less development length compared to a standard hook.

Headed rebar is only available for ASTM A706 and ASTM A615 applications. It is not available for stainless steel applications. The cost of headed rebar will generally exceed that of a standard hook. Therefore, only use them where the benefit of reduced congestion and/or shorter development length is significant.

Bridge Design Manual – June 2020
Oregon Department of Transportation
Section 1 – Design Standards

Do not use headed reinforcement where their use will reduce concrete cover below the minimum required. For this reason, it may be necessary to use standard hooked bars in the corners of a rebar cage that otherwise contains headed bars.

Designate bars which require headed reinforcement on the plans. The *SP 00530* boiler plate special provision requires headed reinforcement to meet ASTM A970. It also requires headed reinforcement products be selected from the ODOT QPL. Therefore, there is no reason to say anything other than “headed bar” on the plans.

Heads may be square, rectangular, round or oval. Minimum head size for square and round heads are provided below. Rectangular and oval head area must exceed 10 times the bar area.

Minimum Head Size for Headed Reinforcement		
Bar Size	Min. Width for Square Heads (in)	Min. Diameter for Round Heads (in)
4	1-1/2	1.6
5	1-3/4	2.0
6	2-1/8	2.3
7	2-1/2	2.7
8	2-3/4	3.1
9	3-1/8	3.5
10	3-1/2	4.0
11	4	4.4
14	4-3/4	5.3

Figure 1.5.5.1.16A

Headed reinforcement will not require project testing. Testing is required as part the QPL approval process. Q/C testing by the manufacturer is also required by ASTM A970.

When proposed by a Contractor, headed reinforcement meeting the minimum head size requirement will generally be acceptable as a direct replacement for standard hooks, except where the head will not allow the required minimum concrete cover.

Use the following minimum development lengths for headed reinforcement.

Development Length for Headed Reinforcement, $F_y = 60$ ksi			
Bar #	$f'_c = 3.3$ ksi	$f'_c = 4.0$ ksi	$f'_c = 5.0$ ksi
4	6"	5"	5"
5	7"	6"	6"
6	8"	8"	7"
7	10"	9"	8"
8	1'-0"	10"	9"
9	1'-6"	1'-2"	10"
10	1'-10"	1'-6"	11"
11	2'-1"	1'-8"	1'-0"
14	3'-0"	2'-4"	1'-3"

* Note: Increase lengths for epoxy coated bars per *LRFD 5.11.2.1.2*.

Figure 1.5.5.1.16B

Apply the modification factors and tie requirements in *LRFD 5.11.2.4.2* and *LRFD 5.11.2.4.3* to headed reinforcement also.

Place adjacent headed bars at a minimum spacing of $6*d_b$. Spacing less than $6*d_b$ can be used if heads from adjacent bars are spaced longitudinally (along the length of the bar) a minimum of $8*d_b$ as shown in *Figure 1.5.5.1.16C*.

When bundled bars are used, one bar in the bundle may be terminated using headed rebar. Terminate other bars in the bundle using standard hooks as shown in *Figure 1.5.5.1.16C*.

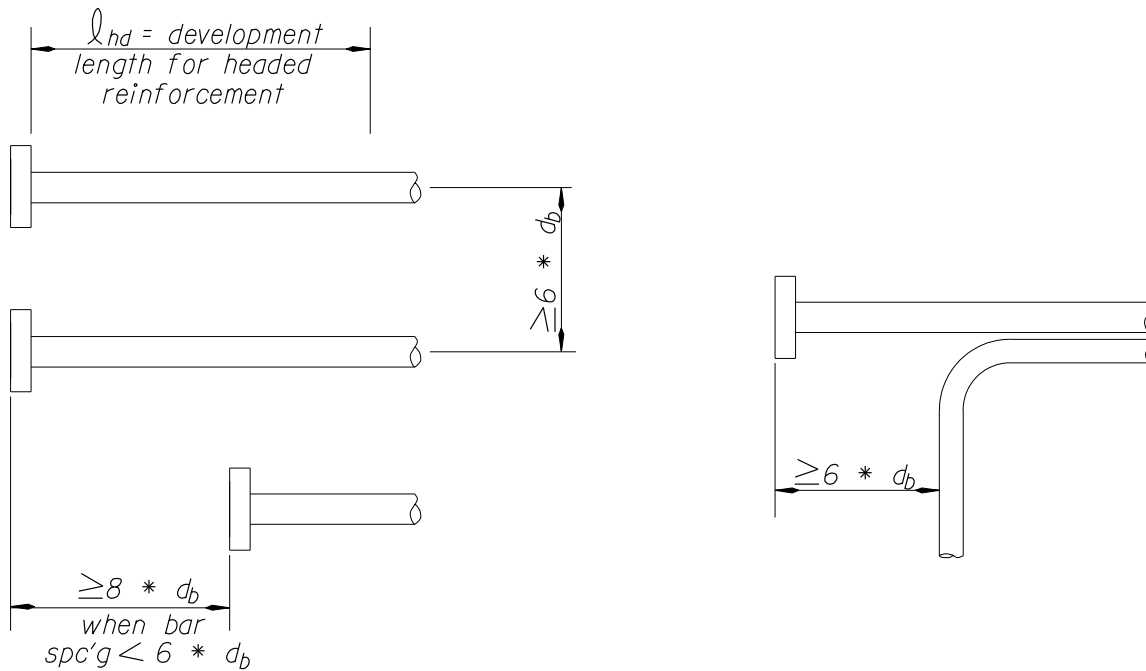

Figure 1.5.5.1.16C

Use of headed reinforcement can result in high concrete compressive stresses under the bar head. Consider the load path for head compression loads and provide distribution steel perpendicular to a headed bar to ensure satisfactory distribution of compressive stresses. The following articles may be useful to understand the load distribution of headed bars:

- *Strut-and-Tie Models for Headed Bar Development in C-C-T Nodes*, Chun and Hong, ACI Structural Journal, Vol. 106, No. 2, March-April 2009, pg. 123-130.
- *Investigation of Dispersion of Compression in Bottle-Shaped Struts*, Sahoo, Singh and Bhargava, ACI Structural Journal, Vol. 106, No. 2, March-April 2009, pg. 178-186.

LRFD 5.11.3 allows for mechanical devices as anchorage. Headed rebar meeting or exceeding the size required by ASTM A970 has been extensively tested. A summary of such testing can be found in Texas Research Report 1855-1, "[Anchorage Behavior of Headed Reinforcement Literature Review](#)", May 2002.

The minimum development lengths for headed reinforcement are based on the greater of:

- 50% of the equivalent hooked bar development length
- Calculations using a combination of head bearing capacity and bar development

Development length calculations were based on concrete bearing capacity under the head plus additional straight bar development length as required to fully develop the yield strength of the bar. The concrete bearing capacity was taken from *LRFD equation 5.7.5-2* and was adjusted using a resistance factor of 0.7 for bearing on concrete per *LRFD 5.5.4.2.1*. Some of the proposed development lengths were increased to provide reasonable transitions between different bar sizes.

ACI 318 allows headed reinforcement, but requires a development length equal to 75 percent of the equivalent hooked bar development length. ODOT believes this is overly conservative for bridge applications.

The following chart illustrates the difference between ODOT and ACI development length requirements.

Development Length for Headed Reinforcement, $F_y = 60$ ksi

f'c	3.3 ksi			4.0 ksi			5.0 ksi		
	Calc	ODOT	ACI	Calc	ODOT	ACI	Calc	ODOT	ACI
#4		6"	7.8"		5"	7.1"		5"	6.4"
#5	4"	7"	9.8"	2"	6"	8.9"	0"	6"	8.0"
#6	8"	8"	11.8"	6"	8"	10.7"	3"	7"	9.6"
#7	10"	10"	13.7"	8"	9"	12.5"	4"	8"	11.2"
#8	12"	12"	15.7"	9"	10"	14.3"	3"	9"	12.7"
#9	18"	18"	17.7"	14"	14"	16.1"	7"	10"	14.4"
#10	22"	22"	19.9"	18"	18"	18.1"	9"	11"	16.2"
#11	25"	25"	22.1"	19"	20"	20.1"	7"	12"	18.0"
#14	36"	36"	26.6"	28"	28"	24.1"	12"	15"	21.6"

 Development length controlled by 50 percent of equivalent hooked bar development length

 Development length based on ODOT calculations, but less than ACI development length

 Development length based on ODOT calculations and exceeds ACI development length

ACI development length = 75 percent equivalent hooked bar development length

Calc = Calculated development length from combination of head capacity and bar development

Figure 1.5.5.1.16D

For concrete strengths above 5.0 ksi, the required minimum development length for headed reinforcement can be calculated using 50 percent of the equivalent hooked bar development length.

1.5.5.1.17 High Strength Reinforcement

ASTM A706 Grade 80

ASTM A706 Grade 80 reinforcement is available on the market. The cost premium for A706 Grade 80 reinforcement is approximately 6-10% over Grade 60. Local steel mills (Cascade Steel Rolling Mills) are producing #5, #8, and #11 bars on a regular cycle and stock these bars. Avoid specifying other bar sizes, otherwise a minimum (combined size and length) of 50 tons is required. However, there can be some flexibility for smaller quantities. Contact Cascade Steel Rolling Mill for requirements when high strength rebar in non-standard rebar sizes is considered for a project with less than 50 tons.

When using A706 Grade 80 reinforcement, the design yield strength is 80 ksi. ASTM A706 reinforcement is weldable. Welding would be needed when A706 Grade 80 reinforcement is used for confinement hoops. The contractor needs to submit a PQR and WPS for approval as is typical for any rebar welding.

ASTM A1035 Grade 100

ASTM A1035 Grade 100 reinforcement has a design yield strength of 100 ksi. Proprietary products that meet the requirements of ASTM A1035 specifications are sold under the brand names of ChromX 9100 (formerly known as MMFX₂), ChromX 4100, and ChromX 2100. The main difference between the three products is the chromium content; the higher the number, the greater chromium content.

The reduced chromium content results in lower cost, when high corrosion resistance is not required. The products are not weldable. Currently, Cascade Steel produces ChromX 9100, ChromX 4100, and ChromX 2100 with a cost premium of approximately 192%, 70% and 45% respectively. Cascade Steel carries some inventory of #5, #8 and #11 bars. For non-stock items, a minimum (combined size and length) of 50 tons is required. However, there can be some flexibility for smaller quantities. Contact Cascade Steel for requirements when high strength rebar in non-stock rebar sizes is considered for a project with less than 50 tons.

ASTM A615 Grade 100

Grade 100 reinforcement according to ASTM A615 requirements is available. The cost premium for A615 Grade 100 reinforcement is approximately 35% over Grade 60. Similar to other high strength reinforcement products, even though there is a required minimum order of 50 tons for combined size and length, there can be some flexibility for smaller quantities. Contact Cascade Steel for requirements when high strength rebar is considered for a project with less than 50 tons.

The cost premiums shown in this article are preliminary and for rebar production only.

Application of High Strength Reinforcement

Do not use high strength reinforcement in members designed for plastic seismic performance (such as bridge columns). Although A706 Grade 80 reinforcement has similar ductile properties compared to A706 Grade 60, testing of full-scale seismic models sufficient to satisfy AASHTO concerns has not yet been completed.

For A1035 Grade 100, the stress-strain property is very different from A706. There is not a well-defined yield plateau. More experimental testing is necessary before its full implementation in members designed to form plastic hinges. The overstrength magnifier as defined for A706 in the Guide Specifications for *LRFD Seismic Bridge Design* may not be appropriate. At this time, an overstrength magnifier of 1.4 is recommended when high strength reinforcement is used in capacity-protected members.

Bridge Design Manual – June 2020
Oregon Department of Transportation
Section 1 – Design Standards

Use of high strength reinforcement is recommended in the following areas:

- **Bridge decks** – When high strength reinforcement is used in a bridge deck, use it for both longitudinal and transverse bars. Refer to *Figure 1.9.1C* and *Figure 1.9.1D* for deck reinforcement design charts.
- **Drilled shafts** – Use of high strength reinforcement reduces cost and congestion in drilled shafts thereby making them more constructible. Drilled shafts are designed for elastic seismic performance and so there would typically be no concern with the seismic performance.
- **Crossbeams & End beams** – Use of high strength reinforcement can reduce cost and congestion in negative and positive moment areas of crossbeams and end beams. Normally these members are capacity-protected; therefore they are designed to remain elastic during a seismic event. High strength reinforcement can be used for temperature steel and stirrups as well.

Grade 80 bars are anticipated to be a better option for a replacement of Grade 60 bars due to lower cost premium and shorter development length compared to Grade 100 bars. In addition, Grade 80 has stress-strain behavior similar to Grade 60 with greater yield stress and ultimate strength.

Within the same member, do not mix different rebar grades of the same bar size. This policy is to avoid any confusion that may occur during construction. It is acceptable to specify different rebar grades in the same member, when the different grades of bar are also significantly different in bar size (at least two bar sizes apart). For instance, longitudinal #8 bars in a crossbeam can be Grade 80 bars, whereas #5 stirrups and temperature bars can be Grade 60.

Figure 1.5.5.1.17 illustrates rebar quantities in the previously mentioned members that are allowed to be reinforced with high strength reinforcement. Note that the quantities shown in the figure will be different if high strength reinforcement is used. A reduction of 10% - 30% in quantities can be anticipated when Grade 60 rebar is replaced by Grade 80 reinforcement.

All bridges in *Figure 1.5.5.1.17* consist of precast prestressed concrete girders with a CIP deck. Most spans are simple for dead load and made continuous for live load. The bridges include drilled shafts with different lengths depending on the soil condition at the sites. Several bar sizes are grouped together since these bars can be alternately used in the design to reduce a number of different bar sizes. It is good practice to specify only a few **and commonly available** bar sizes in each member.

Bridge No.	Length (ft)	Deck Area (ft ²)	No. Drilled Shaft	Span Description	Deck (tons)		Crossbeams* (tons)		Drilled Shaft (tons)	
					#4 - #6	#7 - #9	#4 - #7	#8 - #11	#5 - #6	#9 - #11
22008	968	44015	8 - 8ft	6 - 150ft + 1 - 50ft deck girder spans	106	45	54	51	43**	218**
21576	249	31665	15 - 6ft	2 - 122ft deck girder spans	87	20	36	55	48	87
21343	524	25152	4 - 8ft	3 - 180ft deck girder spans	75	57	29	18	6	37
22248	84	11344	16 - 3ft	1 - 80 ft deck girder span	33	1	12	8	4	10

*includes intermediate diaphragms, end beams, and cap beams.

**A706 Grade 80 rebar

Figure 1.5.5.1.17

As shown in the Figure, **when non-stock rebar is specified, the amount of deck reinforcement in one bar group can meet the required minimum quantity for the first three bridges.** The rebar quantities in

crossbeams and end beams are not sufficient when a 20% reduction due to the use of high strength rebar is applied. For drilled shafts, the amount of reinforcement in one bar group can meet the required minimum quantity only for the first two bridges. However, if high strength rebar of the same size is also used in other members of the bridges, it is possible that the quantities of each bar size will reach the minimum order requirement.

Showing two options of rebar grades on bridge plans is encouraged to accommodate a Contractor that may not be able to obtain high strength bars during a construction project. When this approach is taken, all dimensions need to be prepared to work with both options, especially details related to splice lengths and development lengths. Splice lengths and development lengths for high strength rebar are longer compared to Grade 60.

Couplers are available on the market for high strength reinforcement. These couplers are capable of meeting 125 percent of yield strength. The ODOT Materials Lab has the capability to test rebar couplers up to #14 bars in Grade 100.

1.5.5.1.18 Glass Fiber Reinforced Polymer (GFRP) Reinforcement

Glass fibers have an advantage over other fibers for composite materials because of an economical balance of cost and specific strength properties. Glass fibers are commercially available and exhibit good electrical insulation properties. When glass fibers are encapsulated in suitable resin as a system, the composite material is less sensitive to alkaline environment, freezing and thawing condition, and extremely elevated temperature. These properties make GFRP suitable for use as reinforcement for concrete structures. Through a number of research projects, it has been found that GFRP bars exhibit minimal loss in strength when subjected to sustained tension and have good resistance to fatigue. When GFRP bars are embedded inside concrete, there is no UV exposure concern.

ODOT has used GFRP bars on a number of projects particularly in bridge decks and sound walls. Using GFRP bars in the bridge decks was due to good corrosion-resistant and non-conductive properties. The non-conductive property of GFRP bars does not have detrimental effect to cathodic protection system often used for preserving coastal bridges as long as electrical continuity of adjacent steel reinforcement is maintained. For sound walls, wall weight needed to be minimized. Use of GFRP bars resulted in thickness reduction, since smaller concrete cover could be specified.

Since the release of the 1st Edition of the AASHTO LRFD Bridge Design Guide Specifications for GFRP-Reinforced Concrete in 2009, there have been advancements in material specifications along with new knowledge and field experiences. AASHTO published the 2nd edition of the guide specifications in 2018, which incorporated the new comprehension and extended design provisions for other structural members in addition to bridge decks and traffic railings.

For material specifications, ASTM D7957 published in 2017 includes requirements for material standards of GFRP reinforcing bars. GFRP bars are commercially available from multiple manufacturers and can be produced for construction with a reasonable lead time.

GFRP rebar is a good corrosion-resistant reinforcement alternative for reinforced concrete bridges in corrosive environment compared to ferrous reinforcement due to cost and material strength. Use of GFRP bars does not require electrical isolation to other ferrous reinforcement. Tensile strength of GFRP bars is slightly higher than mild steel reinforcing bars, however GFRP bars have linear elastic behavior, much lower modulus of elasticity, and smaller ultimate tensile strain. Deformation or surface texture, or both, are required to ensure adequate bond capacity. Nominal material properties used for design are shown in Table 1.5.5.1.18A.

Table 1.5.5.1.18A

MATERIAL PROPERTIES FOR DESIGN OF GFRP REINFORCED CONCRETE

Ultimate tensile strength (ksi)	90 ksi (#4 - #6) 75 ksi (#7 - #10)
Tensile modulus of elasticity (ksi)	6,500
Ultimate tensile strain (in/in)	1.1

GFRP reinforcement is recommended for structural members that are located in corrosive environment and do not require high ductility. Service limit states often control design over strength limit states. Do not use GFRP reinforcement in structural members designed for seismic loads and to form plastic hinges.

GFRP bar weight is lighter than steel reinforcement, therefore construction workers are able to handle the reinforcing bars with ease, but more rebar ties are required to maintain GFRP bar position in the rebar cage during concrete pour. GFRP bars are susceptible to abrasion and impact from studded tires and removal tools, therefore use in bridge concrete deck is limited in specific area as shown in *Table 1.26.3A*.

1.5.5.2 Bar Lengths

Use stock bar lengths whenever possible without sacrificing economy. Unless absolutely necessary, don't call for bars longer than 60 feet because they are difficult to handle and transport.

<u>Bar Size</u>	<u>Stock Length *</u>
3	20' & 40'
4 and 5	20', 30' & 40'
6 thru 18	60'

* Only small quantities of #14 and #18 bars are stockpiled by the supplier because of size and weight and may require special mill orders.

Bar lengths specified include hook lengths unless detailed otherwise.

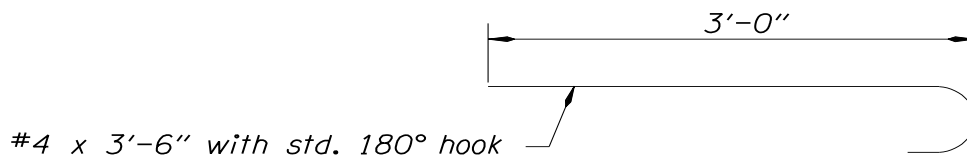

Figure 1.5.5.2A

1.5.5.3 Interim Reinforcement for T-Beams and Box Girders

When the deck slab of a continuous T-beam or box girder is placed after the concrete in the stem has taken its set, place at least 10 percent of the negative moment reinforcing steel full length of the longitudinal beam to prevent cracks from falsework settlement or deflection. In lieu of the above requirement, 2 - #8 bars full length of longitudinal girders may be used.

In concrete crossbeams whose principal negative reinforcement lies in the deck slab, locate a portion of the negative reinforcement in the stem of the crossbeam below the level of the deck slab construction joint. Provide sufficient ultimate reinforcement capacity to support 150 percent of the dead load of the crossbeam and superstructure 5 feet along the centerline of the structure either side of the center of bent. Use no less than 10 percent of the total negative reinforcement.

In cases where the bent crossbeams are skewed to the deck steel, place the top crossbeam steel in the top of the stem below the deck (dropped panel). See the following page for typical details.

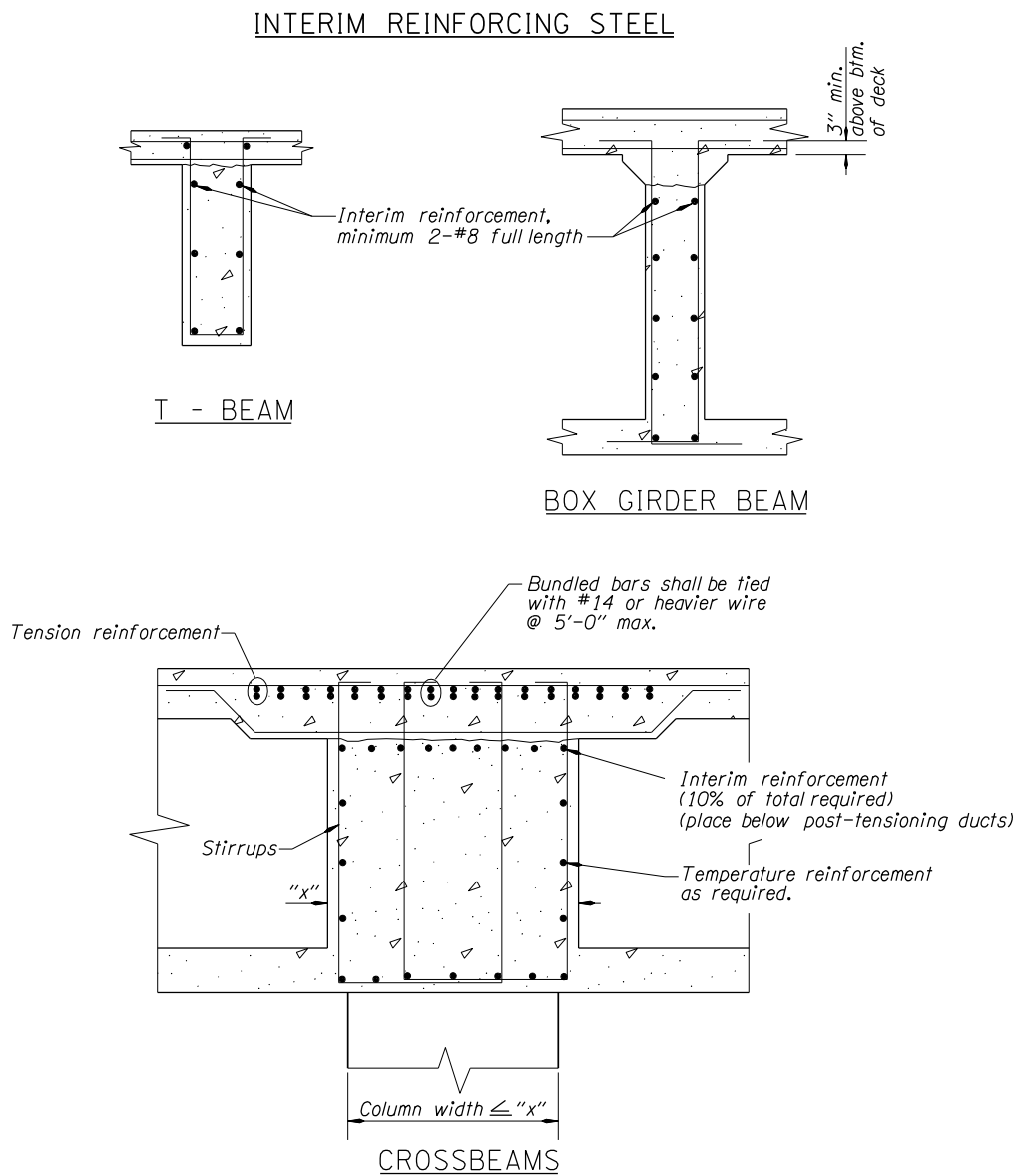

Figure 1.5.5.3A

1.5.5.4 Additional Shear Reinforcement

As shown below, provide additional reinforcement to the calculated shear reinforcement in cantilevered portions of crossbeams. Pay careful attention to clearances and possible conflicts with post-tensioning ducts and other reinforcement. Detail the size and number of bars to provide at least 20 percent of the factored Strength I Limit State shear demand at the face of the column. Apply this provision to cantilevered sections of crossbeams when the crossbeam cantilever from the face of the column exceeds the crossbeam depth at the face of the column. This additional reinforcement may be omitted if the shear reinforcement provided from the critical shear section to the face of column provides 20 percent additional capacity above the controlling strength limit state.

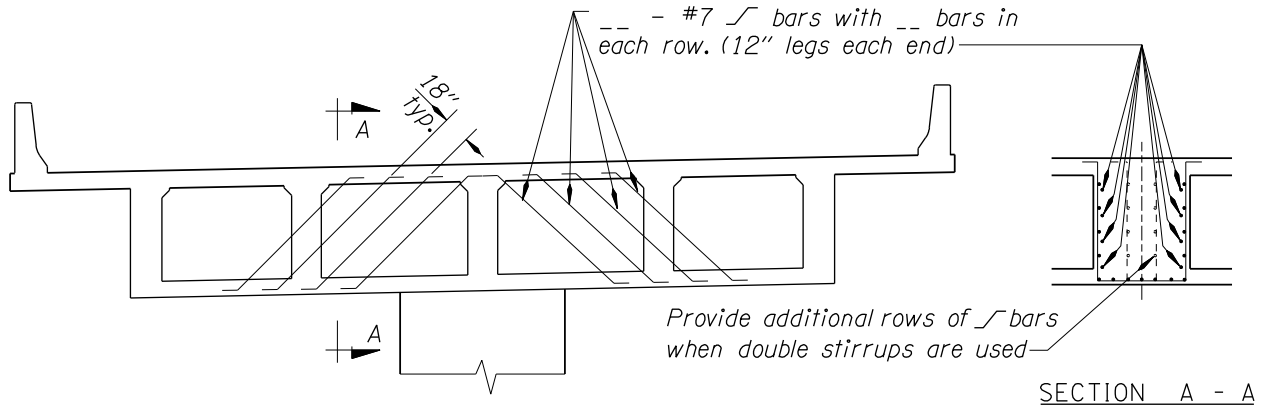

Figure 1.5.5.4

1.5.5.5 Diaphragm Beam Reinforcement

The detail below assumes the deck reinforcement is stopped 6" clear of the transverse beams. The added bars provide reinforcement for Beam-D and the deck overhang. If straight bars are used, the spacing of the deck steel will be continuous over the transverse beams and no additional bars will be required.

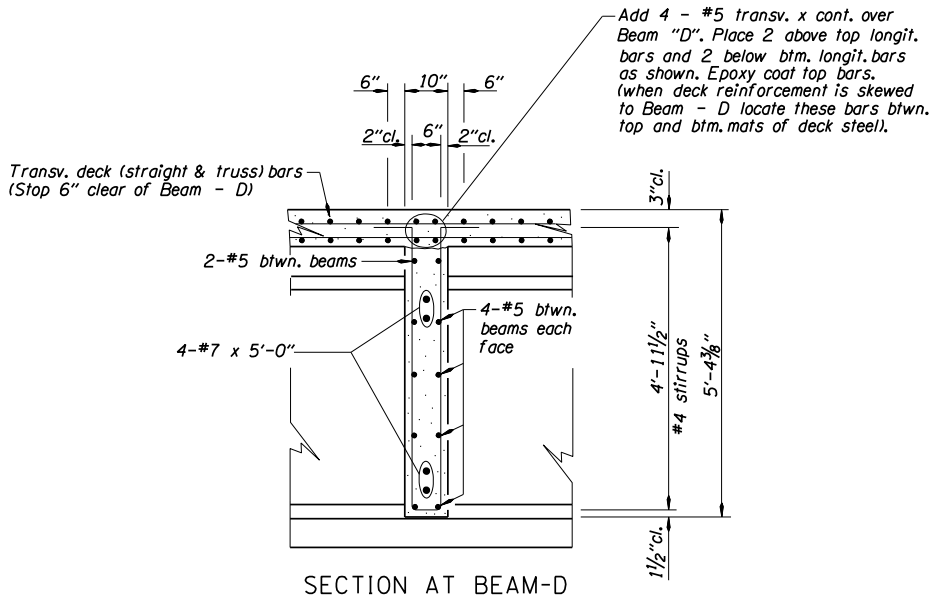

Figure 1.5.5.5

1.5.6 Precast Prestressed Concrete Elements

1.5.6.1 Design of Precast Prestressed Elements

The nature of precast prestressed elements requires special handling in several areas.

Design – General

- Each precast prestressed element is to be designed job specific.
- Deck requirements:
 - Side-by-side slabs and box beams: 5 inch minimum HPC thickness with a single mat of reinforcement (8 inch maximum centers each way). 7 inch minimum thickness for any portions overhanging the exterior slab or box beam.
 - Side-by-side Bulb-T and deck Bulb-T girders: 7-1/4 inch minimum HPC thickness with two mats of reinforcement (8 inch maximum centers in each mat and each direction).
 - Spread slabs and box beams: 8 inch minimum HPC thickness with two mats of reinforcement (8 inch maximum centers in each mat and each direction).
 - Bulb-T (not side-by-side) and Bulb-I girders: 8 inch minimum HPC thickness (see *BDM 1.9.1*).
 - Deck Bulb-T girders with UHPC connection: Precast concrete Deck Bulb-T girders are connected using UHPC at flange ends to form bridge deck. Air entrained concrete is required for girder top flange portion (8 inch minimum thickness). The deck girder system and connection details are shown in Figure 1.5.6.1. See BDM 1.9.1.1.1 for more information on UHPC. 3/4" thick minimum PPC overlay is applied on top of the deck girder system.

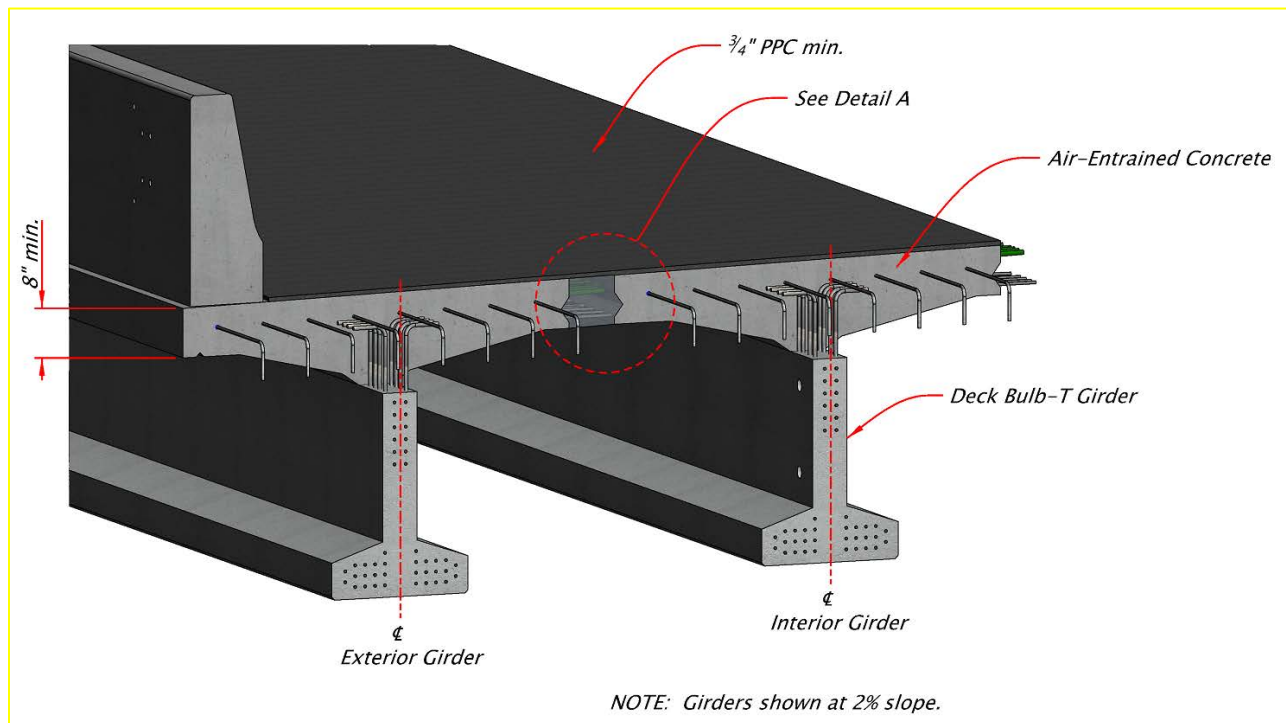

Figure 1.5.6.1 Section View

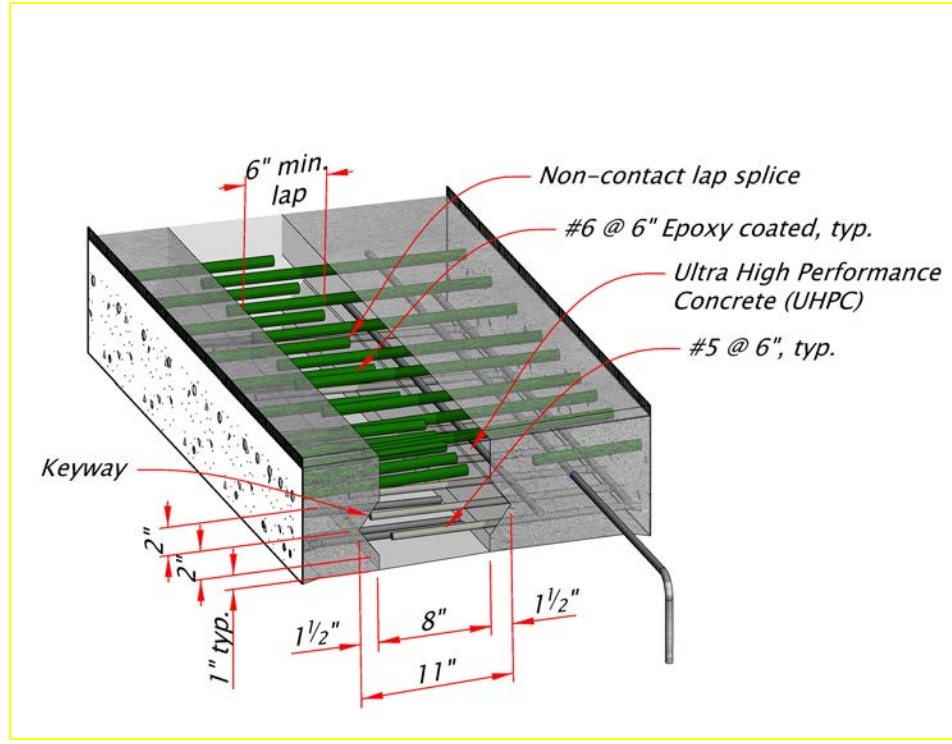

Figure 1.5.6.1 Flange Detail

- HPC decks must be cast-in-place, unless full-depth precast panels are used with either longitudinal post-tensioning or ultra-high performance concrete closures.
- Asphalt concrete wearing surfaces are not recommended on concrete bridge decks and may be used only with an appropriate membrane per *BDM 1.26.4*. Approval from the bridge owner is required for the use of asphalt concrete wearing surfaces on all new bridges.
- Concrete Strength – Ensure concrete design compressive strengths are not higher than actual design requirements. List the required concrete strengths in the General Notes.
- The allowable range of design compressive strengths of concrete at 28 days (f'_c) to be used are:

	<u>Minimum</u>	<u>Maximum</u>
for precast, prestressed slabs and box beams	4000 psi	7000 psi
for precast, prestressed girders, and integral deck girders	5000 psi	9000 psi

When precast, prestressed members are used without a cast-in-place deck, the 28-day compressive strength is limited to 6000 psi. This limitation is required to ensure adequate air entrainment and to ensure adequate workability. Higher strength concretes generally are less workable and therefore are more difficult to achieve an acceptable finish suitable for a riding surface. If a separate concrete mix (6000 psi or less) is used for the top flange, then higher strengths (up to 9000 psi) may be used for the remainder of the member.

- The allowable range of design compressive strengths of concrete at release of prestress (f'_c) to be used are:

	<u>Minimum</u>	<u>Maximum</u>
all precast, prestressed members	4000 psi	7000 psi

- Do not exceed the compressive strengths listed above without an approved design deviation from the State Bridge Engineer.
 - Concrete Tensile Stress Limits:
 - $3 * \sqrt{f'c}$, where $f'c$ is in psi.
 - Modify *LRFD Table 5.9.4.1.2-1* as follows:
 - Modify the 9th bullet to $0.0948 * \sqrt{f'c}$, where $f'c$ is in ksi.
 - “No Tension” criteria in 6th and 8th bullets still apply.
 - Modify *LRFD Table 5.9.4.2.2-1* as follows:
 - Modify the 1st and 8th bullets to $0.0948 * \sqrt{f'c}$, where $f'c$ is in ksi.
 - “No tension” criteria in 3rd, 5th and 7th bullets still apply.
 - Simple-Span Girders Made Continuous for Live Load – When precast girders are made continuous for live load, design the positive moment area as if the girder was simply-supported. A maximum concrete tensile stress up to $6 * \sqrt{f'c}$ in the positive moment area will be allowed for this condition. Also ensure that the maximum concrete tensile stress in the positive moment area does not exceed $3 * \sqrt{f'c}$ when the girder is considered continuous for live load.
- Use a load factor of 0.80 for live loads in Service III load combination to check tensile stresses in prestressed concrete members with prestressing strands and reinforcing bars.
- Prestress Losses – Calculate prestress losses in precast members according to *LRFD 5.9.5.4* – Refined Estimates of Time-Dependent Losses. This method of calculating losses is the “Detailed” method presented in [NCHRP Project No. 18-07](#).

An Excel spreadsheet for calculating prestress losses using the NCHRP 18-07 methods is available from the Bridge Engineering Section. This spreadsheet includes multiple methods for calculating prestress losses. Use the “Detailed” method.

Prestress loss estimates by past ODOT bridge designers have generally been in the 35 to 45 ksi range. The *LRFD 5.9.5.4* loss calculations appear to be consistent with earlier loss predictions. And these loss levels have resulted in relatively accurate predictions of camber at the time of deck placement. There has also been no record of service cracking in bridges designed using these prestress loss levels.

Using prestress gain from loads permanently applied to girders, such as selfweight, bridge deck, superimposed dead loads, is allowed.

Do not include the prestress gain due to application of live load in the total long-term loss calculation.

The amount of prestress gain due to application of live load can be more than 20 percent of the total prestress loss. ODOT’s policy of not including this gain results in a conservative estimate of final girder stresses. Note that prestress loss affects girder stress, but does not change the ultimate strength or capacity to carry permit loads.

Transforming the prestressing strand to increase section properties is not recommended. As stated in [NCHRP 18-07](#), prestress losses should be calculated differently (no elastic losses or gains) when transformed properties are used for the prestressing strand. If so, the final girder stresses will be approximately the same whether gross or transformed section properties are used. Therefore, there is no significant advantage in using transformed section properties.

- Girder Shape Selection

General – The Oregon Bulb-T girder shape is preferred for most Oregon bridge applications. This shape has a 4 foot wide top flange. This top flange provides safety for workers who must form bridge decks and ensures stability of the girder during shipping. Use Bulb-T girder shapes whenever it is appropriate to do so.

Bulb-I girders are a standard variation of the Bulb-T. To make a Bulb-I, the fabricator will start with the Bulb-T form and add blockouts to portions of the top flange to make the Bulb-I shape. Use the Bulb-I shape only when it has benefits over a Bulb-T. Since Bulb-I girders have a narrow top flange, it requires less concrete build-up over the girder compared to a Bulb-T. Therefore, bridges with high superelevation (generally, greater than 7 percent) may be candidates for the Bulb-I shape.

Since the Bulb-I section is 3 inches taller than the equivalent Bulb-T, it may be preferred for span lengths slightly longer than the equivalent Bulb-T capability. A Bulb-I section may provide benefits over a deeper Bulb-T section. However, due to shipping stability and worker safety concerns, a deeper Bulb-T might still be preferred if the deeper section can be accommodated within the available vertical clearance.

Modified Bulb-T girders include those having a non-standard top flange width and those having a wider web. Fabricators are generally able to adjust the top flange width anywhere from 24 inches to 48 inches. At least 3 inches can also be added to the top flange. Discuss any modifications to the top flange with Oregon fabricators before placing modified details on plan sheets. Design deviations are not required for top flange modifications.

Only adjusted web thickness when necessary to accommodate post-tensioning (such as for spliced girders). For such cases, increase the web thickness from 6 inches to 7.5 inches. When doing so, increase the top and bottom flange widths by the same amount.

BT90 & BT96 girder sections are the largest in the Oregon inventory. These sections have a 5 foot wide top flange which is necessary to ensure shipping stability of very long girders. Do not consider changes to the top flange width without concurrence from Oregon fabricators. The longest girder available from Oregon fabricators is around 185 feet total length. Verify availability for any girder length exceeding 180 feet.

BT96 girders have not yet been used in Oregon. Verify availability of this section before specifying it on a project.

Roadway surface is directly provided by Deck-Bulb Tee girders with UHPC connection. Because girders are erected plumb, the top flanges are required to be cast on a slope equal to a specified superelevation. To ensure constructability of flange concrete, a superelevation is limited to 5% maximum. Specify thicker PPC overlay (3.75 inches maximum) and thickened flange near beam ends as required to match roadway vertical profile. See *DET3385* and *DET3386* for details.

Due to its function as the roadway surface, construction requires minimal differential camber between adjacent girders in the span. The construction specification requires a tight camber difference, however there will be some residual camber variation due to construction tolerances. Also, overfilling of the connection is a common placement method for casting UHPC. As a result, grinding is required to smooth out the uneven surface. Subtract ½ inch flange thickness in the design to account for top surface grinding. 15% over-designed capacities are recommended as reserve capacities for locked-in force effects from the girder camber adjustment during construction.

AASHTO Type II, Type III, Type IV, and Type V shapes do not have the same efficiency as Bulb-T shapes. Therefore, use Bulb-T shapes in most cases. Use of AASHTO shapes is generally limited

to bridge widenings where the existing bridge has AASHTO shapes. There may also be rare cases when an AASHTO shape may provide slightly less vertical clearance compared to the available Bulb-T shape.

WSDOT Shapes – Obtain approval of a design deviation before specifying a standard WSDOT shape on an Oregon project. Approval of design deviations will generally only be considered where there is no equivalent Oregon section to meet an application. The standard specifications allow contractors to propose an alternate shape provided it is similar to the specified shape and meets all project requirements (see *SP 00550.03*). However, the original contract plans must use Oregon shapes.

Spliced Girders with post-tensioning can be used to extend span capabilities of precast concrete girders. Consult with Oregon fabricators regarding the appropriate section and segment lengths for spliced girder applications.

Consult with Oregon fabricators before considering using haunched girders. Although haunches may provide an aesthetic benefit, any structural benefit from haunching a prestressed girder is minimal.

Trapezoidal Box Girders are available for applications that require special aesthetic considerations. Trapezoidal box girders can either have a uniform depth or parabolic haunches. Horizontally curved trapezoidal boxes have been used in Colorado.

Strand Type – Bulb-T and AASHTO girders were developed for use with 0.5 inch diameter prestressing strand. Do not consider use of 0.6 inch diameter strand for these sections without first consulting with Oregon fabricators. Modification of the girder section may be needed to accommodate 0.6 inch strand. BT90/96 sections were developed for use with 0.6 inch strand.

Shipping – When selecting the appropriate girder type, review potential shipping routes to make sure the proposed girder type can be shipped to the bridge site. Narrow roads and sharp curves may restrict the length of girder that can be used. Our Oregon fabricators can generally provide assistance in this analysis.

Oregon Fabricators – The following northwest precast concrete fabricators can provide precast concrete members to Oregon bridge projects:

- RB Johnson, McMinnville, OR
 - Concrete Tech, Tacoma, WA
 - Knife River, Harrisburg, OR and Spokane, WA
- Detailing – General
 - Camber - See *BDM 1.5.9* for special requirements pertaining to ACWS, sidewalk, and rail requirements.
 - Deck Drainage - See *BDM 1.24* for details specific to slab and box beam elements.
 - Girder Storage and Shipment - *SP 00550.49* prohibits transportation before 7 days and only after the 28-day compressive strength has been achieved. There may be special construction circumstances when a member needs to be transported and placed before the 7 days, but it is not recommended before the 28-day compressive strength has been achieved.
 - When design requires a delay for placing the girder on bearing devices to decrease the bearing thickness or encasing the beam ends for fixed connection to reduce restraint moments due to long-term shrinkage and creep effect, specify a required wait time on the plan sheet.

Bridge Design Manual – June 2020
Oregon Department of Transportation
Section 1 – Design Standards

- Skew - Limit skew to 45 degrees for precast slabs and 30 degrees for precast boxes. Excessively skewed slabs and boxes tend to warp more, making fit and obtaining uniform bearing on the bearing pads more difficult. Stair stepping the bearing pads may be necessary to obtain uniform bearing.
- Stage Construction of Slabs and Boxes with cast-in-place HPC decks – Do not use side-by-side slabs or boxes with HPC decks when precast elements must be placed in stages. Such stage construction does not allow tie rods to be placed as detailed in *BR445*. Spread slabs or boxes with a 7-1/4 inch minimum deck thickness (two mats of deck steel) would be an acceptable option for bridges constructed in stages.
- Transverse Connection for Side-by-Side Slabs and Boxes – Connect side-by-side slab and box elements with transverse tie rods as detailed on *BR445*. Alternate connection details, such as intermittent weldments, are not allowed.
- Surface Finish for Precast Members - The standard specifications requires a light broom finish on the tops of members having an asphalt wearing surface and a roadway finish for members having a HPC deck. A roadway finish combined with extending stirrup legs up into the deck is considered sufficient to provide adequate capacity to ensure composite action between the girder and deck. It is not necessary to require additional roughening.
- Interface Shear – For all members with a cast-in-place deck, provide interface shear reinforcement full length of the member regardless of whether or not it is required by design. This requirement is satisfied by extending stirrups from the precast member up into the deck slab and will result in minimum reinforcement across the interface shear plane equal to two #4 bars at 18 inch centers.
- Joint and Keyway details - see standard drawings for recommended details.
- See *Appendix 1 Figures* for other typical details.

1.5.6.2 Design and Detailing of Precast Prestressed Girders

1.5.6.2.1 Stay-in-Place Forms

Where the spacing between edges of precast concrete girder flanges is no greater than 2 feet, steel stay-in-place deck forms may be used. However, do not use stay-in-place forms in exterior bays.

Steel stay-in-place deck forms may also be used behind end beams where the deck is continuous over interior bents. Hot-dip galvanize all steel stay-in-place forms.

If stay-in-place deck forms are used, provide a minimum section modulus of 0.15 in³/ft and a maximum form height of 1.5 inches. Install stay-in-place forms such that the top of the form is at the design bottom of deck thickness. The weight of a form meeting these requirements is likely to be less than 2 psf. This weight is not significant and need not be included in the design. However, add 10 psf additional non-composite dead load in the girder design to account for extra concrete weight.

Do not use stay-in-place forms at deck overhang areas or where the edges of girder flanges are greater than 2 feet apart. In such cases, access for inspection and future maintenance of the deck precludes the use of stay-in-place deck forms.

Do not use stay-in-place forms in coastal areas.

These provisions apply to precast girders, slabs and boxes.

Where stay-in-place forms are considered, add the following statement with the loading section of the general notes:

“Stay-in-place deck forms may be used except for exterior overhangs and between the exterior girder and the first interior girder on each side of the structure. XX psf additional non-composite dead load has been included in the girder design to account for extra concrete and form weight associated with stay-in-place forms.”

1.5.6.2.2 Diaphragm Beam Restraint

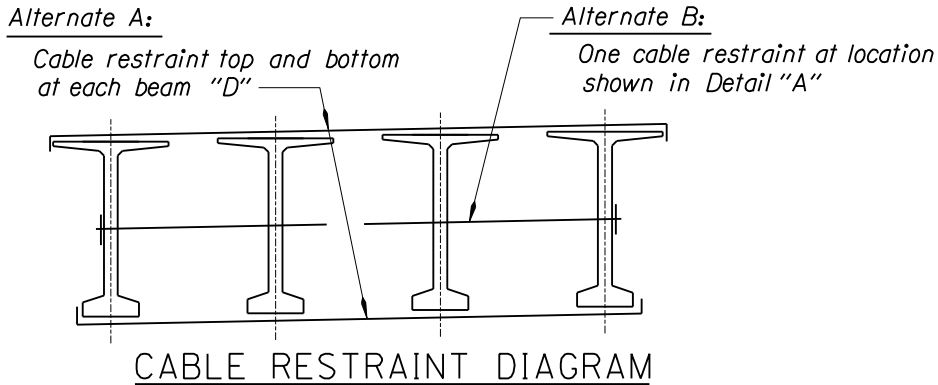

Snug fit prestressed beams against forms prior to diaphragm pour. Restraint to remain in place a minimum of two days after completion of diaphragm pour.

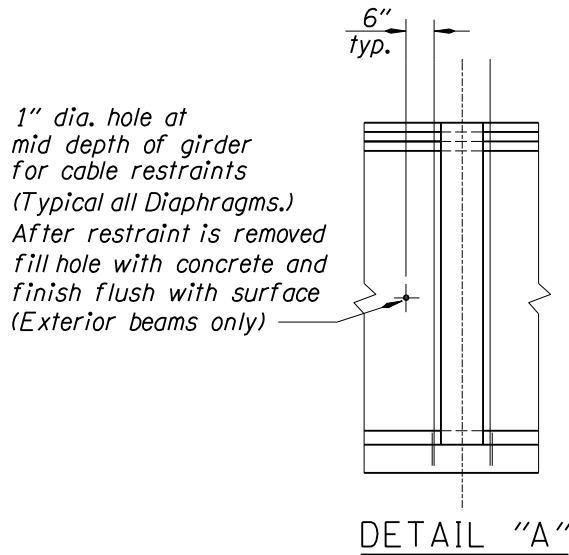

Figure 1.5.6.2.2

1.5.6.2.3 Beam Seat or Top of Crossbeam Elevation

Provide a note on the plans indicating if the beam seat (or top of crossbeam) elevations shown are for deck buildups based on three months camber. Adjust the beam seat (or top of crossbeam) elevations during construction to correct for the revised deck buildups.

1.5.6.2.4 Continuous Deck Reinforcement

Provide additional deck reinforcement for bridges composed of precast simple span elements with continuous deck as shown below. This detail does not apply to bridges made continuous for live load. When girders are made continuous for live load, the deck reinforcement must resist the negative moments generated. The result will be substantially more deck steel than the detail below. NCHRP Report 519 provides design examples for girders made continuous.

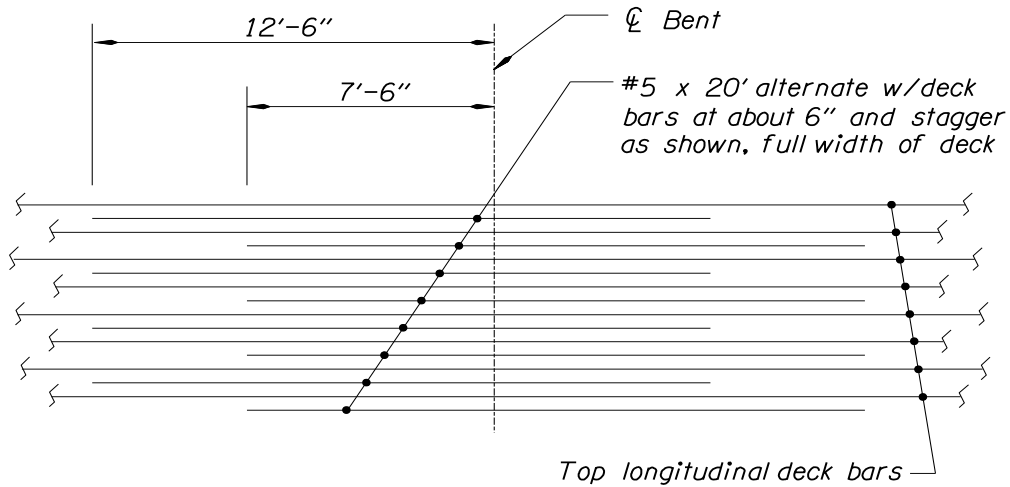

INTERIOR BENT WITH CONTINUOUS DECK

Figure 1.5.6.2.4

1.5.6.2.5 Beam Stirrups

Bulb-T and Bulb-I standard drawings show stirrups with 90 degree shop bent hooks at the top of the girder. These hooks must protrude at least 3 inches above the bottom of the deck. If they do not, because of excessive build-up, the standard drawing requires the use of "U" bars to fill the gap.

There is no need for the stirrup hooks or "U" bars to extend to the top mat of deck reinforcement, as has been shown in the past. Detail plans to reflect these requirements.

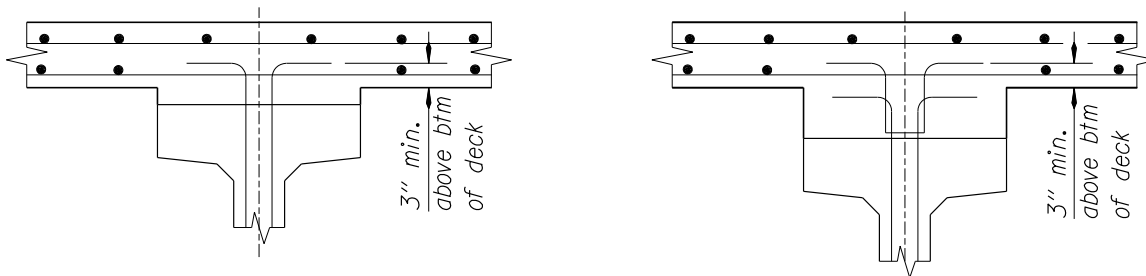
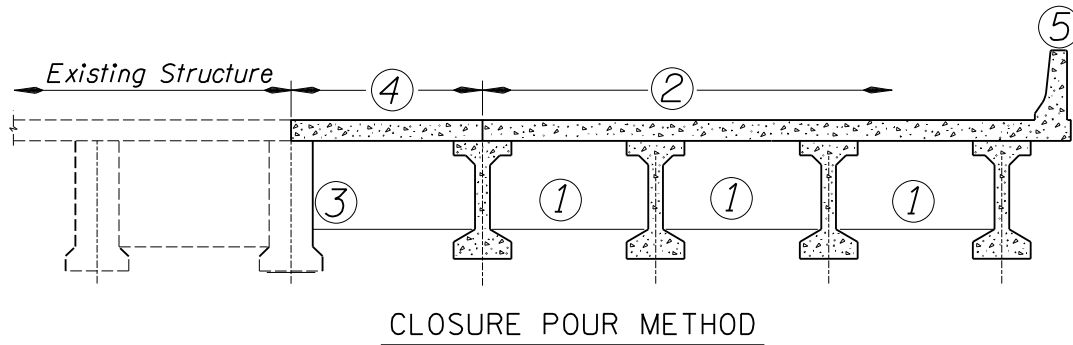

Figure 1.5.6.2.5

1.5.6.2.6 Structure Widening, Precast Beam Bridges

Detail connections between superstructures to prevent widening dead loads from being transferred to the existing beams. This may be accomplished by delaying the connection pour (diaphragm and deck) until most of the dead load is applied to the widening. The designer chooses the appropriate placement method.



POUR SCHEDULE
(INCLUDING CLOSURE POUR)

- | | |
|---|--|
| <ul style="list-style-type: none"> ① Make pour in diaphragms ② Make pour in deck slab. Delay pour ② a min. of 3 days after pour ①. ③ Make pour in diaphragm of closure pour section. | <ul style="list-style-type: none"> ④ Make pour in deck slab of closure pour. Delay a minimum of 3 days after pour ③. ⑤ Make pour in bridge rail. |
|---|--|

Figure 1.5.6.2.6A

Note: In the above closure pour method, the deck screed machine would normally be placed or supported on the widening beams. As the concrete is placed, the beams tend to deflect equally. This equal deflection normally gives better control of deck thickness and deck steel cover.

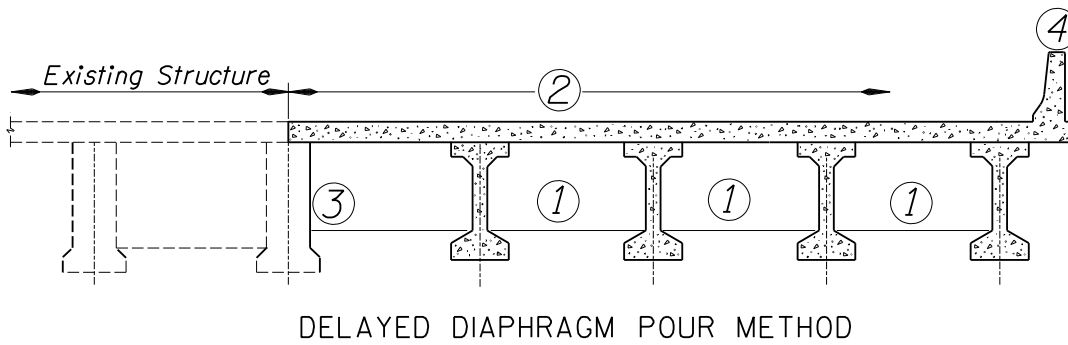

POUR SCHEDULE

- | | |
|--|---|
| <ul style="list-style-type: none"> ① Make pour in diaphragms ② Make pour in deck slab. Delay pour ② a min. of 3 days after pour ①. Blockout deck as required to make pour ③. | <ul style="list-style-type: none"> ③ Make pour in diaphragm closure a minimum of 3 days after pour ②. ④ Make pour in bridge rail. |
|--|---|

Figure 1.5.6.2.6B

Note: In the above delayed diaphragm pour method, the deck screed machine rails would normally be placed or supported with one rail on the existing structure and one rail on the widening beams. As the concrete is placed, the new beams would tend to deflect more than the existing composite beams. This unequal deflection makes it more difficult to control deck thickness and deck steel cover, especially at the new beam adjacent to the existing structure.

1.5.6.2.7 Deck Pour Sequence

Place decks on precast prestressed beams no less than 60 days after stress transfer. This is to allow a majority of the prestress camber to occur, thus enabling more accurate determination of beam build-up for the deck screeding.

1.5.6.2.8 Diaphragm Beams

Intermediate diaphragms distribute loads from over-height vehicle, vessel and large debris collision. Use CIP diaphragm beams at ends of each span. Use full depth CIP diaphragms. The full depth diaphragms are more effective in distributing the impact loads.

Use the following span length criteria to determine the number of intermediate diaphragms for bridges crossing over major truck routes including Interstate 5, Interstate 84 and routes with 20-year projected ADTT > 5000; or waterways where there is a high probability of large debris or vessel collision.

<u>Span Length</u>	<u>Location</u>
40 ft – 80 ft	Midspan
81 ft – 120 ft	1/3 points
> 120 ft	1/4 points

For other bridges, one set of intermediate diaphragms at midspan is recommended. Stagger and place intermediate diaphragms perpendicular to girder centerline, when the skew is greater than 25 degrees.

Install temporary diaphragms midway between the end and midspan diaphragm beams before pouring the end and midspan diaphragm beams (see [BR350](#)). Temporary beams may be removed after removing the deck overhang brackets.

1.5.6.2.9 Earthquake Restraint Details

See cost data books for sample plans and details.

1.5.6.2.10 Fixed Girder Connections

Where girder ends are designed with a fixed connection to an end beam or bent cap, embed the girder into the end beam (or bent cap) a minimum of 8 inches. Provide transverse bars/rods through the girder ends as shown on the standard drawings ([BR300](#) & [BR310](#)). In addition to the above requirements, provide strand extensions and/or dowels at the end of the girder as needed to ensure adequate transfer of loads to the substructure.

To minimize restraint moments due to girder creep and shrinkage, establish continuity when the age of the girders is at least 28 days after casting. Submit a design deviation when the construction schedule requires earlier continuity construction. **When a certain concrete age is required by design to minimize the time-dependent effect,** include the following note in the plan sheet with continuity details: "Place continuity diaphragm at least XX days after the girders are manufactured."

1.5.6.2.11 Girder Spacing

Limit girder spacing to 9 feet for girder sections up to BT72 and 1.5 times girder depth for larger girders.

(1) Precast Members topped with ACWS - Side-by-side elements have been historically topped with ACWS over a waterproofing membrane. This type of construction works well in a stage construction scenario as long as the elements are placed consecutively from one side to the other.

When using this type of construction, the previous stage precast element at the stage construction joint must carry some of the wearing surface dead load from the subsequent stage since adjacent slabs must have their tie rods connected before the wearing surface is placed for the subsequent stage. This additional load is generally ignored (i.e., the members are designed as if they were all placed in one stage). Long term creep is thought to mitigate this condition. To date, annual inspections have found no distress in precast elements due to this practice.

For cases where elements cannot be placed consecutively from one side to the other, it becomes impossible to place standard transverse tie rods. For this reason, select a different structure type (ex., spread slabs or girders with CIP deck) when elements cannot be placed consecutively. Any side-by-side precast slab or box element must be connected to adjacent elements with transverse tie rods as detailed in [BR445](#). Alternate details, such as intermittent weldments, are not allowed.

The use of asphalt concrete wearing surfaces are no longer recommended due to long term maintenance concerns.

(2) Precast Members topped with CIP concrete – Side-by-side elements may be topped with an HPC deck. See [BDM 1.5.6.1](#) for minimum deck thickness and reinforcing requirements.

For this type of construction, the deck dead load is substantially larger than the PPC or ACWS case. For this reason, this type of construction must be detailed to prevent the deck dead load from later stages from being transferred to previous stages.

One solution to this problem is to provide a space (12 to 18 inches) between the stages that is filled with a CIP closure girder which is placed after full deck dead load is applied to both adjacent sections. For this case, design the precast members adjacent to the construction joint as exterior girders. Design the CIP closure girder to carry a contributory portion of live load under the strength limit states.

Use of spread slabs or boxes is another possible solution for stage construction. If so, use 7-1/4 inch minimum deck thickness with two mats of steel as required by [BDM 1.5.6.1](#).

Any side-by-side precast slab or box element must be connected to adjacent elements with transverse tie rods as detailed in [BR445](#). Alternate details, such as intermittent weldments, are not allowed.

1.5.7 Cast-In-Place Superstructure

1.5.7.1 General Design

(1) Structure Depths

See [BDM 2.5.2\(2\)](#) for minimum depth and live load deflection requirements.

(2) Computations of Deflections

Base computed deflections on the effective moment of inertia of the section.

Estimate long-term deflections as instantaneous deflection times a factor of three for reinforced concrete elements.

1.5.7.2 Interim Reinforcement for T-Beams

See *BDM 1.5.5.3*.

1.5.7.3 Diaphragm Beam Steel

See *BDM 1.5.5.5*.

1.5.7.4 Box Girder Stem Flare

Taper changes in girder stem thickness for a minimum distance of 12 times the difference in stem thickness. See Standard Detail *DET3125* for details.

1.5.7.5 Shear Keys and Construction Joints

Normally, shear keys at construction joints are unnecessary. Show construction joints with a roughened surface finish unless shear keys are required and shown on the plans.

At construction joints between the stem and slab of concrete girder bridges, use the following note:

Roughened surface finish. See *SP 00540.43(a)*.

1.5.7.6 Standard Access and Ventilation in Concrete Box Girders

Provide permanent access to all cells of concrete box girders. Access may require using manholes and/or access holes through bottom slabs, diaphragm beams, crossbeams and longitudinal beams. Standard Drawings *BR135* and *BR136* show standard access and ventilation details. See *BDM 2.6* for additional accessibility guidance.

In addition to the standard drawing for Access Holes, draw a section on the plans normal to the girder through the access hole showing the relationship of the longitudinal stems, utility lines, and crawl holes to the access hole and ladder. If the drawing is to scale, dimensions need not be shown.

Use the following guidelines tempered with engineering judgment.

- Deck Access Holes – Avoid placing access holes through the deck of a structure. There is a potential for the access hole cover to leak. Also avoid disruption of traffic and the need for traffic protection and direction.
- Bottom Slab Access Holes - Single span bridges will normally require one access hole per cell. Multiple span bridges will normally require one access hole per cell at each end of the bridge. Locate access holes in accordance with the guidelines shown on the standard drawings. The 8 feet minimum height to the access hole is recommended to discourage unauthorized access into the structure. Keep the inspector in mind when choosing the access locations. Do not place access holes over railroad tracks.

- Girder Stem Access Holes - Girder stem access holes are to be provided through the interior stems at the midpoint of all spans. These lateral access points will allow the inspector to complete their inspection of span or spans without having to exit and reenter the structure.
- Crossbeam Access Holes - These are not detailed on the standard drawing since their design will vary widely because of structural requirements. However, only one access hole will be required per crossbeam if the girder stem access holes are provided.
- Bottom Slab Ventilation Holes - These ventilation holes, similar to the bottom slab access holes in design except top opening, are intended to be used in all cells of each span not having access holes. Generally, the ventilation holes would be located near the opposite end of the span from an adjacent span having access holes. The holes provide additional ports for removing forms, serves as an exhaust hole when forced ventilation is required and provides additional natural ventilation.
- Stem Ventilation Holes - These holes provide for the escape of lighter-than-air gases and are located near the high point of each span as detailed on the standard drawings.
- Ladder Support - The ladder support provides a safe support for the ladder while the inspector unlocks the access hole cover. After the cover is unlocked, reposition the ladder through the access hole so the inspector can grab onto the ladder while entering or leaving the box girder cell.
- Access Cover Prop - The access cover prop is designed to facilitate the opening or closing of the cover when the ladder is supported by the Ladder Support. Once the ladder is through the access hole, release the prop so the cover will lie flat. The prop would be re-engaged upon exiting the box.

1.5.7.7 Form Removal

All forms are to be removed from cells where access is provided.

Deck forms to be removed may be supported off the bottom slab if the bottom slab is fully supported, designed to support the added load and has no detrimental effect on the structure.

Deck forms for non-accessible cells may be left in place. Deck forms left in place are not to be supported off the bottom slab. Web supported deck forms are acceptable. Include an allowance for deck form dead load in the design loads, see *BDM 1.3.4*.

1.5.7.8 Bottom Slab Details

Generally, show the bottom slab of box girders to be parallel to the top slab in transverse section so that all girder stems will be the same depth.

Provide a bottom slab thickness of no less than 6 inches.

For skewed box girders, orient bottom slab transverse bars the same as the deck transverse bars. See *BDM 1.9.1* and *LRFD 9.7.1.3* for requirements.

Place a 4" x 4" drain hole through each diaphragm beam at the low point of each cell. Place a 4 inch diameter drain hole through the bottom slab at the low point of each series of cells in a span. For cells that carry water lines, increase 4 inch diameter to 6 inch diameter.

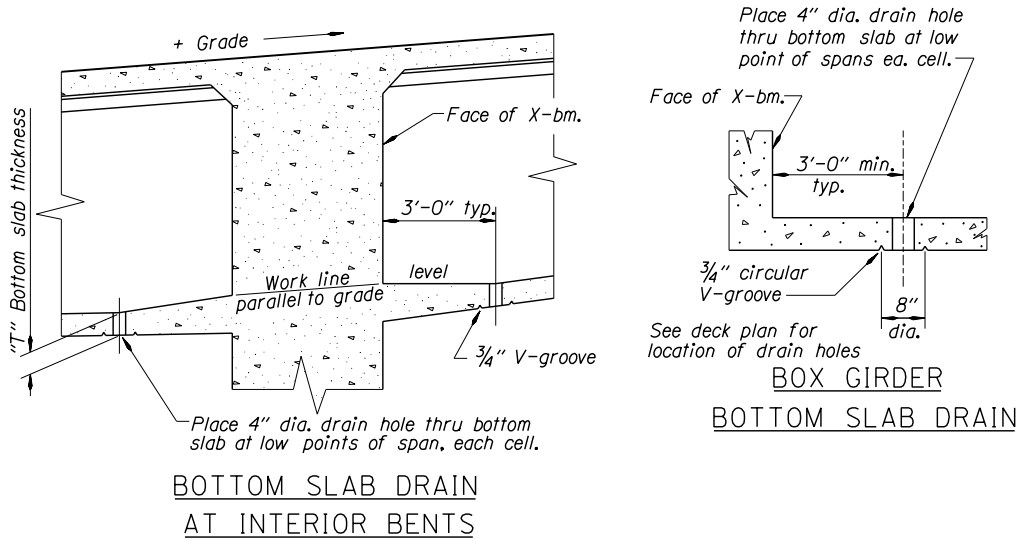

Figure 1.5.7.8

1.5.7.9 CrossBeams

See *BDM 1.5.5.3* and *BDM 1.5.5.4*.

1.5.7.10 Fillets

Provide adequate fillets at the intersections of all surfaces within the cell of a box girder, except at the junction of web and bottom flange where none are required.

Provide a 4 x 4 inch fillet at the intersection of the crossbeam and the deck; and the end diaphragm beam and the deck.

1.5.7.11 Structure Widening, Cast-in-Place Superstructures

Detail connections between superstructures to prevent widening dead loads from being transferred to the existing beams. One method is to temporarily support the beam adjacent to the widening during construction. Designate locations where supports are required and expected maximum reactions. An alternate method requires closure pours for the diaphragm and deck slab.

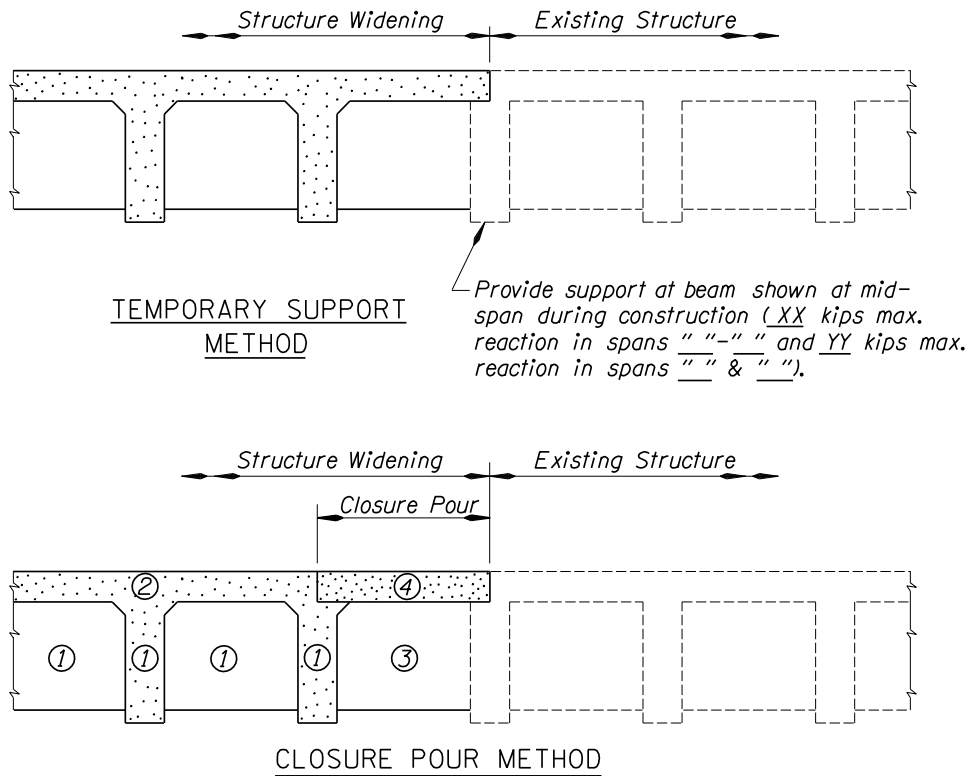

POUR SCHEDULE

- ① Pour longitudinal beams and diaphragm beams shown to the bottom of the top fillets.
- ② Pour ② includes top fillets and deck slab. Pour ② to be delayed a minimum of 3 days after pour ①. A deck construction joint may be made over any diaphragm beam. Delay pouring adjacent section of deck a minimum of 36 hours.
- ③ After falsework removal, pour diaphragm closure section.
- ④ Make closure pour in deck slab. Delay a minimum of 3 days after pour ③.

Figure 1.5.7.11

1.5.7.12 Stay-in-Place Forms for Deck

For deck construction, stay-in-place forms will not be allowed. Loss of access for inspection and future maintenance of the deck preclude the use of stay-in-place deck forms.

1.5.8 Post-Tensioned Structures

1.5.8.1 General Design

(1) Structure Depths

See **BDM 2.5.2(2)** for minimum depth and live load deflection requirements.

(2) Shrinkage and Creep Stresses

The stresses in the superstructure and substructure of post-tensioned concrete bridges which result from elastic shortening may be assumed to remain in the structure indefinitely. The stresses which might be assumed to develop as the result of shrinkage and creep may be assumed to be relieved by creep.

(3) Shortening of Post-Tensioned Bridges

The following values for shortening of post-tensioned, cast-in-place concrete bridges are based on field measurements by the ODOT Bridge Section. Compare the design values with the field measured values and use the more conservative value.

Shrinkage prior to tensioning (theoretical)	
0.4 x .0002 ft/ft x 12 in/ft x 100 ft =	0.10"/100'
Elastic shortening	0.44"/100'
Shrinkage and creep after tensioning to 1 year	0.29"/100'
Shrinkage and creep 1 year to 20 years (anticipated)	0.10"/100'

These structures were stressed to an average concrete stress of 1200 psi (1000 to 1300 psi). For other values, the elastic shortening and creep is roughly proportional. ODOT data indicates that variation of these values by 50 percent would not be unusual.

(4) Deflections

Estimate long-term deflections as the net instantaneous deflection (DL + Prestress) times a factor of two for cast-in-place post-tensioned elements.

(5) Curved Post-Tensioned Ducts

Design for the radial prestress forces resulting from curved tendons in post-tensioned structures. Additional shear/flexural reinforcement may be required to resist the lateral web forces and ties to resist the web bursting forces.

(6) Design Moments at Interior Bents of Post-Tensioned Bridges

For crossbeams with widths less than the distance between the top and bottom slab, do not include the crossbeam in the superstructure section properties. Project the stem and slab dimensions to the centerline of the bent and use those dimensions to calculate section properties. Use the negative moment at the bent centerline for design.

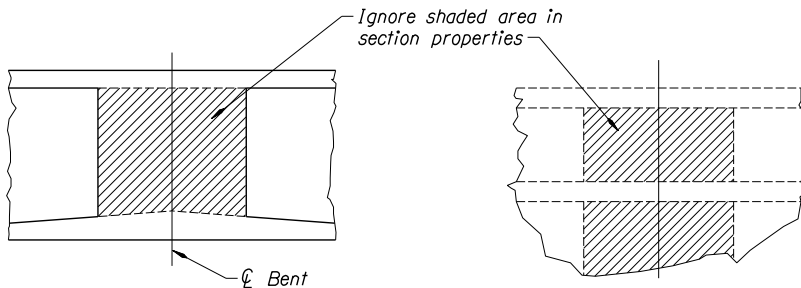

Figure 1.5.8.1

For greater crossbeam widths, use the above section properties and consider adding supplementary reinforcing steel across the top of the crossbeam to control any theoretical cracking that may occur from live loading.

(7) Skewed Box Girders

Box girder bridges with skews of over 20 degrees cannot be safely designed without taking into account the effects of skew. These effects generally increase as any of the following increase: skew angle, span length, torsional rigidity of the superstructure. The principal effect of skew is to increase the reactions at the obtuse corner of the structure and to reduce those at the acute corners (sometimes even causing uplift). This increases shear in the beams adjacent to the obtuse corners and produces transverse shear in the deck and bottom slab. These effects can be reduced by reducing the skew, which generally means lengthening the structure and/or by placing crossbeams at interior bents normal to the centerline of the structure.

When torsion due to skew is a problem, consider reducing the torsional stiffness of the structure. RCDG bridges, either cast-in-place or with precast girders, are torsionally limber.

Do not design box girder bridges with bents skewed more than 45 degrees from the normal to the structure centerline.

Careful design of post-tensioning with regard to the deflection and slope of the girder at a skewed end can nullify or reverse the tendency of the obtuse corner of the skewed structure to take a disproportionate part of the dead load. Theoretically, this could be done so that under full DL+LL+I, the reactions would be equal at all bearings. Even an approximation of this condition will benefit the design.

(8) Concrete Tensile Stress Limits

The concrete tensile stress limits given in *BDM 1.5.6.1* also apply to post-tensioned members.

1.5.8.2 General Details

Details and practices stated in *BDM 1.5.7* generally apply to post-tensioned box girders as well as conventional box girders.

(1) Conventional Box Girders

See Standard Details *DET 3125* and *DET 3130* for general details.

(2) Precast Trapezoidal Box Girders

See Standard Drawing *BR133* and Standard Details *DET 3131*, *DET 3132* and *DET 3134* for general details.

(3) Access and Ventilation

See Standard Drawings *BR135* and *BR136* for general details.

1.5.8.3 Post-Tensioned Deck Overhangs

Place post-tensioning ducts and deck reinforcement normal to the centerline of the structure.

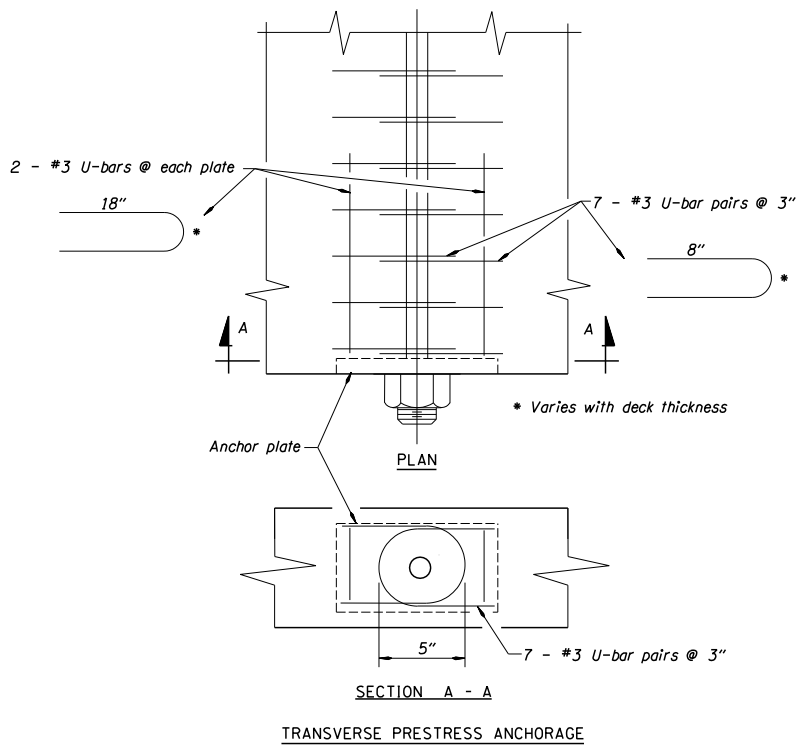
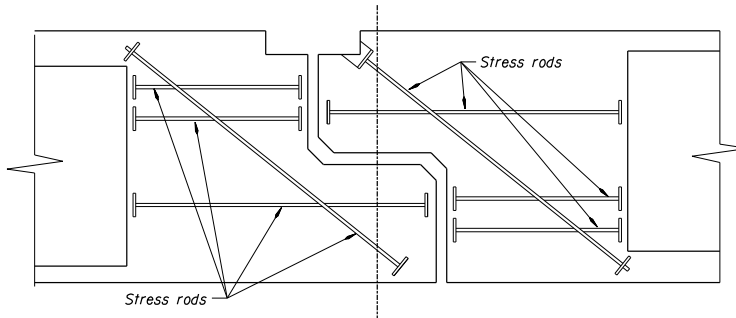

Figure 1.5.8.3

1.5.8.4 Stress Rod Reinforcement of Bearing Seats

A recent example of a stress-rod reinforced bearing seat is shown below. In order to retain a significant amount of prestressing force, provide a rod with stressed length of not less than 10 feet.



STRESS ROD REINFORCEMENT OF BEARING SEATS

Figure 1.5.8.4

1.5.8.5 Segmental Construction

Where precast and cast-in-place concrete elements are joined in a continuous, segmental structure, chamfer the exterior corners of the cast-in-place portion to match the precast elements. It is standard practice to chamfer precast elements, even though the chamfer may not be shown on our drawings or the shop drawings.

1.5.8.6 Support Tower Details and Notes

Design the support tower at the end of the suspended span to support the reaction from the suspended span including the additional reaction due to post-tensioning. Show on the plans the approximate total reaction in kips. Design the tower to accommodate the elastic shortening of the superstructure due to post-tensioning. Make provisions so that the superstructure may be returned to the plan elevation (raised or lowered) in the event that actual settlement at the top of the tower differs from the anticipated settlement. Keep the support tower in place until the suspended span is fully supported by the cantilever and adjoining span.

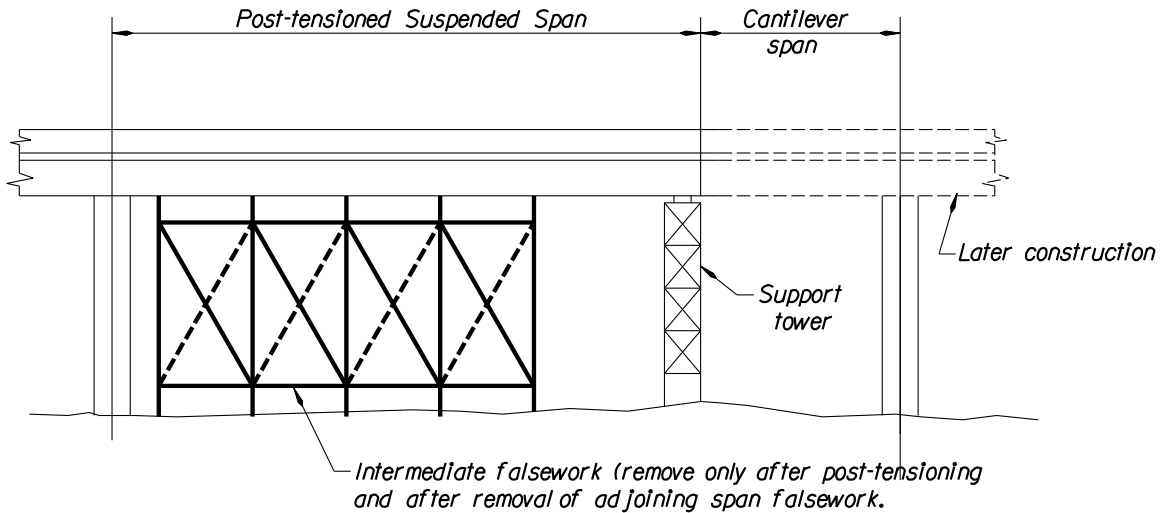

Figure 1.5.8.6A

1.5.8.7 Reinforcement of Deck Overhangs

In order to prevent cracking at the end of post-tensioned spans, extend the end diaphragm beam to the edge of the deck or provide additional diagonal deck reinforcement similar to shown below.

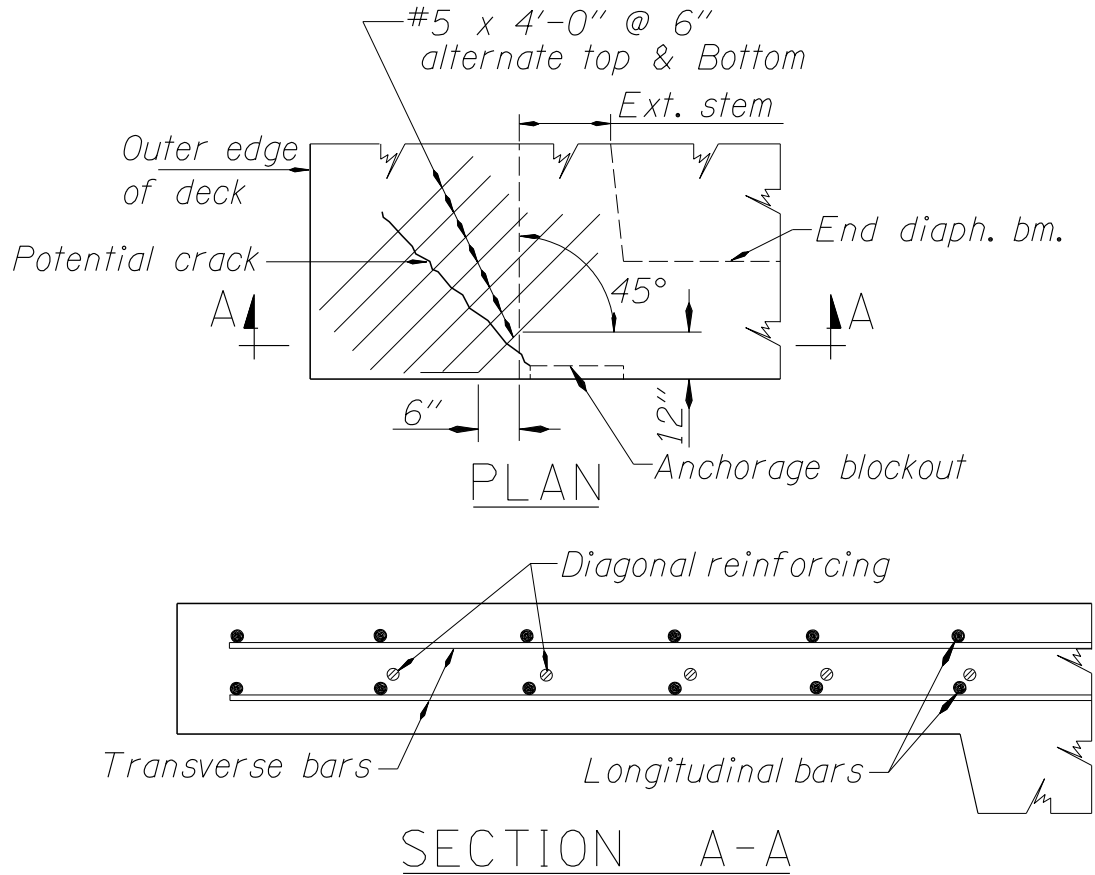
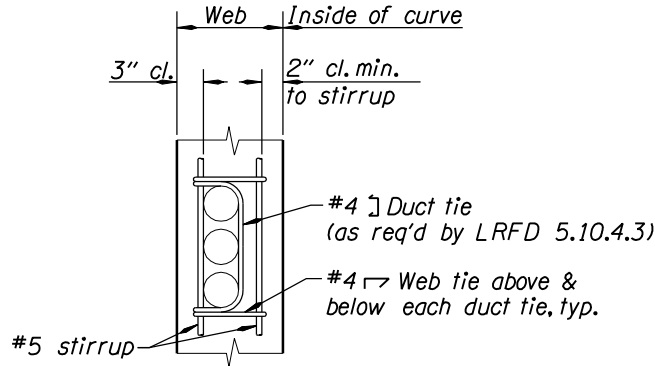

Figure 1.5.8.7

1.5.8.8 Post-Tension Strand Duct Placement

Place ducts for post-tensioned bridges using the detail provided on *DET3130*. The most common type of duct arrangement has been the bundled duct detail. This detail can be used when the duct size does not exceed 4-1/2 inches and when the horizontal curvature of the bridge does not require the use of supplemental ties (see *LRFD 5.10.4.3*). When the horizontal curvature does result in the need for supplemental ties, do not use bundled ducts. When supplemental ties are required due to horizontal curvature, use the following detail:



TYPICAL WEB AND DUCT TIE DETAIL

Figure 1.5.8.8A

Detail post-tensioned box girders to allow pouring the bottom slab and stems as separate pours. Design the prestressed tendon path to ensure that the ducts do not fall in the area of the bottom slab. See Standard Details *DET 3125* and *DET 3130* for general details. To ensure the ducts are fully encased in concrete, do not place ducts in the bottom slab and keep ducts at least 1 inch below the fillet construction joints near the top slabs. Show the following details on the project plans if needed:

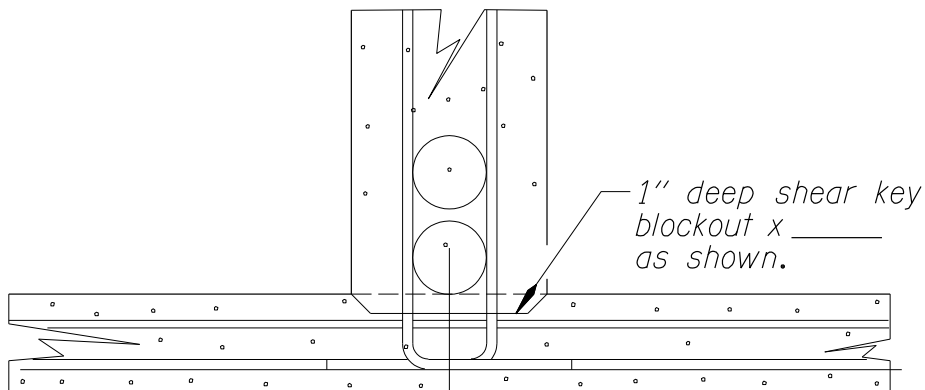

LOW POINT DETAIL

Figure 1.5.8.8B

Bridge Design Manual – June 2020
Oregon Department of Transportation
Section 1 – Design Standards

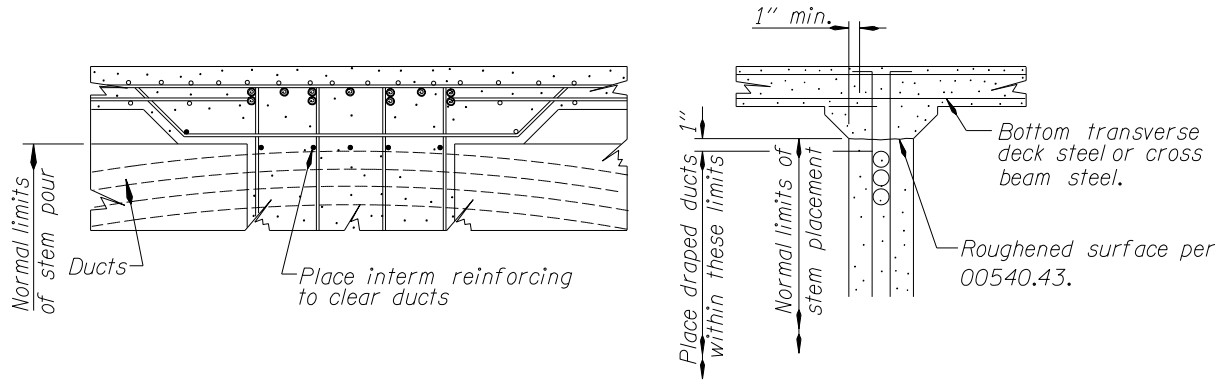

HIGH POINT DETAIL

Figure 1.5.8.8C

In some cases it may be necessary to place ducts outside the limits shown above. If so, special concrete placement details will normally be needed to ensure the ducts are fully encased in properly consolidated concrete for the entire length of the bridge. For these cases, submit a design deviation request which shows the proposed duct placement detail. Include with the request the details and/or specification language intended to ensure the concrete will be fully consolidated in areas where the ducts penetrate either into the bottom slab or above the stem fillet construction joint.

1.5.9 Camber Diagrams

1.5.9.1 Camber Diagrams, General

Show camber diagrams on the plans for all types of cast-in-place concrete structures. The camber diagram shall be titled, "Camber Diagram" and be accompanied by the applicable portions of the following note:

Camber is designed to compensate for deflection due to prestressing, the dead load of all concrete, stay-in-place forms and wearing surface and the long-term effects of shrinkage and creep.

An example of a camber diagram for a cast-in-place structure is shown below.

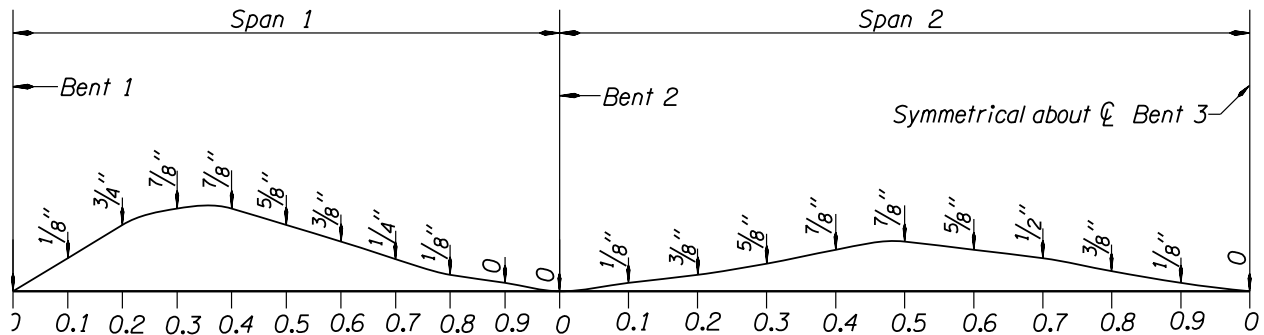

Note:
 Camber is designed to compensate for deflection due to prestressing, the dead load of all concrete, stay-in-place forms and wearing surface and the long term effects of shrinkage and creep.

CAMBER DIAGRAM

Figure 1.5.9.1

1.5.9.2 Precast Slabs and Box Beams

Camber of precast elements has increased in recent years due to higher strand forces. Reflect allowances for camber and grade correction in top of slab elevations. Rail posts lengths and curb heights will have to be increased accordingly near the ends to obtain the proper finish rail height and curb exposure. Note on the Typical Deck Section that post lengths may vary due to camber and/or superelevation. Include information on the contract plans as follows:

Note:
 Deck elevations shown are top of concrete slab,
 ___ below finish grade as calculated below:

Min. ACWS----- 3"
 Anticipated camber @ 3 mos.----- + ___
 Downward due to ACWS----- - ___
 Min.wearing surface thickness @ Bents-- ___

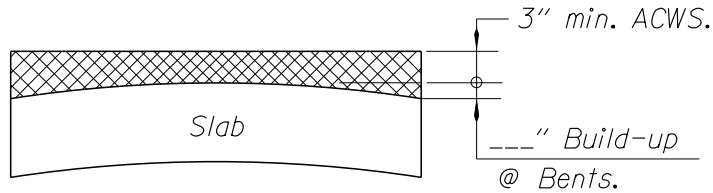

ACWS BUILD - UP DETAIL

Figure 1.5.9.2

1.5.10 Pour Schedules

1.5.10.1 Pour Schedules, General

In order to avoid misunderstanding and claims by the contractor, take care to make sure that construction sequences and pouring schedules are clearly described. Particular care is needed if symmetrical structures are covered by sketches showing half of the structure.

In general, longitudinal pours in continuous spans are stopped near the bents to allow concrete shrinkage to occur in the majority of the span. Closure pours over the bent are generally shorter to minimize shrinkage cracking that could occur between fixed supports or placements.

It is recommend to place bottom slab or beam construction joints at a falsework bent rather than a permanent bent. Cracking may develop at a permanent bent, if the adjacent falsework settles or deflects during the concrete placement.

1.5.10.2 T-Beams Supported on Falsework

A typical sketch and pour sequence is shown below.

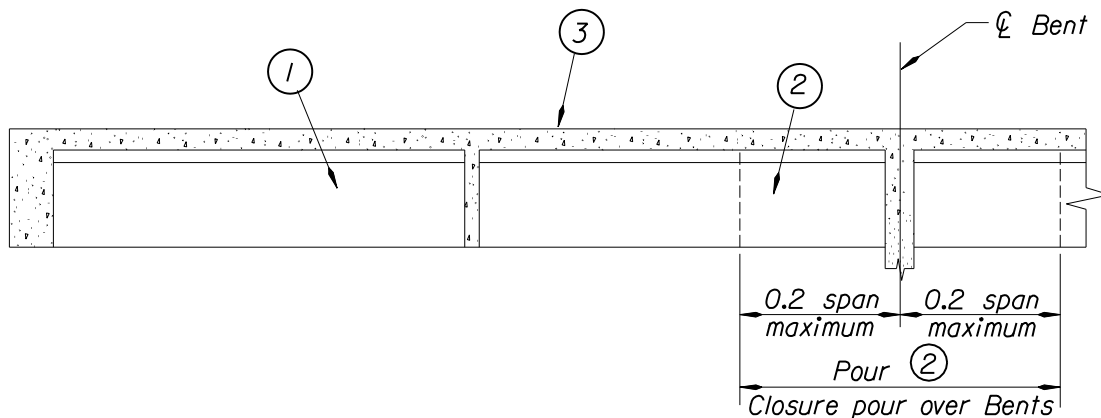

Figure 1.5.10.2

POUR SCHEDULE

1. Pours (1) and (2) are the longitudinal and transverse beams to the bottom of deck (or fillets). Make all Pours (1) prior to Pours (2). Beam construction joints shall not be near a permanent bent but shall be made at a falsework bent. Delay adjacent beam pours by a minimum of 3 days.

2. Pour (3) is the (fillets and) deck. Pour (3) to be delayed a minimum of 3 days after completion of all Pours (2). A deck construction joint may be made over any transverse beam. Delay pouring adjacent sections of deck a minimum of 5 days. Do not remove bulkheads for deck pours until at least 3 days after completion of pour. Deck pours may extend over any part of a span or spans so long as they meet these requirements.

1.5.10.3 Box Girders on Falsework

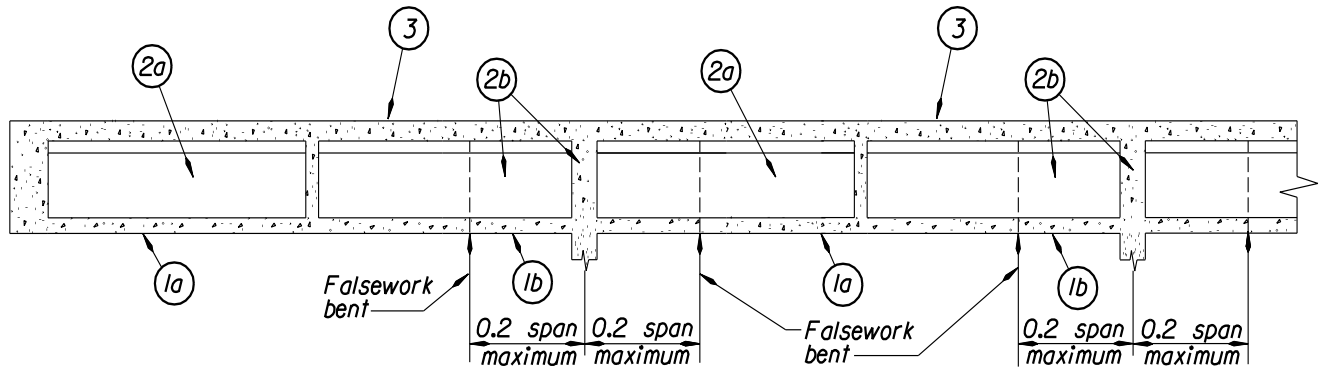

Figure 1.5.10.3

POUR SCHEDULE:

1. Pours (1a) and (1b) are the bottom slab. Stop Pours (1) at a falsework bent and not at a permanent bent. Delay a minimum of 3 days between adjacent Pours (1). Complete all Pours (1a) prior to starting Pours (1b). Complete all Pours (1) prior to starting Pours (2).
2. Pours (2a) and (2b) are the longitudinal and transverse beams to the bottom of the fillets. Stop Pours (2) over a falsework bent. Delay the start of Pours (2) a minimum of 5 days after bottom slab Pours (1) are complete. Delay a minimum of 3 days between adjacent Pours (2).
3. Pour (3) includes the fillets and deck slab. Pour (3) to be delayed a minimum of 3 days after completion of all Pours (2). Pours (3) may be stopped over any transverse beam, with the use of a deck construction joint. Delay a minimum of 5 days between adjacent Pours (3). Do not remove bulkheads for deck pours until at least 3 days after completion of the pour. Deck pours may extend over any part of a span or spans as long as they meet these requirements.

Generally, it is preferred that the bottom slab be completely poured first and separately from the longitudinal beams. This ensures a more uniform bottom slab thickness, the slab provides a good base for stem forms, and the continuous bottom slab helps stabilize the falsework system. It also allows the falsework to take its initial settlement without affecting other superstructure components.

1.5.10.4 Drop-In Precast Prestressed Elements

Complicated types of construction require detailed construction sequence notes, such as the following:

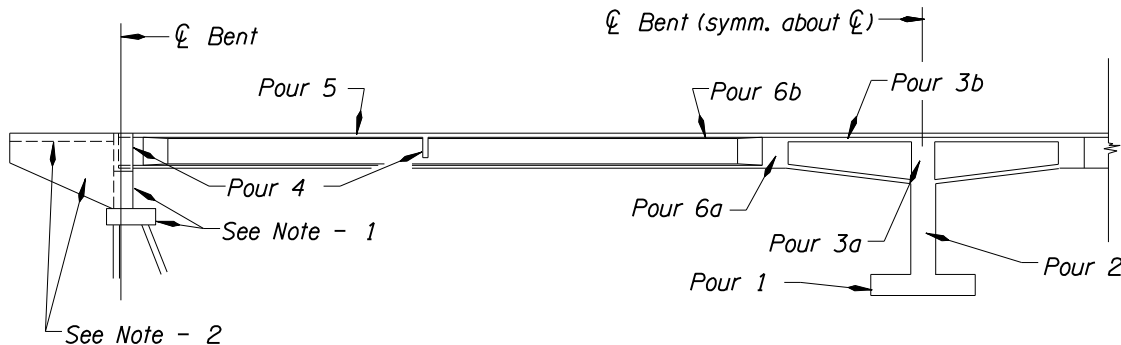

Figure 1.5.10.4

POUR SCHEDULE:

1. Make Pour (1).
2. Make Pour (2) , includes Bent 2 column.
3. Make Pour (3a) , includes bottom slab and webs to bottom of top fillet, Beam "C" to bottom of deck.
4. Make Pour (3b) , includes deck and top fillets for cast-in-place section. Delay Pour (3b) a minimum of 3 days after completion of Pour (3a).
5. Apply Stage I post-tensioning to cast-in-place section. Stressing to begin a minimum of 14 days after completion of Pour (3) , but not until concrete in Pour (3) has reached its design strength.
6. Place prestressed beams. Beams to be placed so that the number of beams in one span does not exceed by more than 4 the number in the opposite span.
7. Make Pour (4) , includes diaphragm beams "D" and end beams "E".
8. Make Pour (5) , (no less than 60 days after transfer of stress in precast, prestressed beams), includes deck on prestressed beams to diaphragm beam nearest Bent 2.
9. After Pour (5) has been made in Spans 1 and 2, make Pour (6a) , includes remainder of Beam "C". Let concrete take initial set, and make Pour (6)b , includes remainder of deck.
10. Apply Stage II post-tensioning to assembled Spans 1 and 2. Stressing to begin a minimum of 14 days after completion of Pour (6) , but not until concrete in Pour (6) has reached its design strength.
11. Pour curbs.

NOTES:

1. Bents 1 and 3 footings and walls may be poured any time up to 7 days prior to placing of prestressed beams, but concrete must have reached its design strength prior to beam placement. No part shall interfere with post-tensioning operations.

2. Paving slab and sidewalls may be poured at any time except that no part shall interfere with post-tensioning operations.
3. Screed deck concrete parallel to bents.
4. Composite decks and/or closure pours shall not be made until at least 60 days have elapsed from the time of transfer of prestressing force in the precast elements.

1.5.10.5 Continuous Cast-in-place Slabs on Falsework

For pours over 600 cy, allow a transverse deck construction joint at 0.2(span) from the next interior bent.

1.5.10.6 End Bents

If the fit of superstructure elements is critical, be sure to consider the end bent construction sequencing. Normally the end wall construction is delayed until the superstructure elements are in place. Delaying the end wall construction also allows the contractor to compensate for errors in superstructure element lengths and end bent locations. Show a construction sequence diagram, with notes, as needed.

1.5.10.7 Steel Girders

See *BDM 1.6.1.9* for example.

1.6 STEEL STRUCTURE DESIGN AND DETAILING

[1.6.1 Steel Girders](#)

[1.6.2 Welding](#)

[1.6.3 Galvanizing and Painting](#)

[1.6.4 Bolts and Connections](#)

[1.6.1 Steel Girders](#)

Estimating Structural Steel Weights and Preliminary Design

For the preliminary quantities or preliminary girder design, an estimate of steel weights for built-up plate composite I-girders can be obtained from the [Span to Weight Curves](#) from the AISC website. The Steel Span to Weight Curves are the quickest way to determine the weight of steel per square foot of bridge deck for straight, low skew, plate girder bridges. The Curves are organized by span arrangement (1, 2 or 3 or more span bridges) and girder spacings. The Curves also provides a good double check on final quantities.

For more detailed design, refer to the [Continuous Span Standards](#) from the AISC website. The Continuous Span Standards include 88 unique solutions for 3 span bridges with center spans between 150'-0" and 300'-0", girder spacing between 7'-6" and 12'-0", and plate girder designs utilizing both homogenous and hybrid steel options. Each conceptual solution is presented in tables with girder plate sizes, diaphragm spacing, intermediate stiffener sizes and locations, shear connector spacing, camber, and girder weights.

Design

Design according to *AASHTO LRFD Bridge Design Specifications* unless specified otherwise in this document.

ODOT does not require Certified Erector qualification for erection of steel bridges. For a complex project in which a contractor with such qualification is deemed necessary, obtain Bridge Engineering Section approval prior to including such requirement in the contract documents.

Curved and skewed deck girder bridges have the potential for three dimensional deflection and rotation. Longer spans magnify the rotation of the girders and cause unaccounted stresses on the diaphragm connections. Include a note in the contract drawings stating that the girder webs are plumb in the final condition. This requires the erector to force fit the diaphragms with the girders out-of-plumb prior to deck placement. Rotation of girders resulting from the deck placement plumbs the girders web and releases stresses caused from force fitting the diaphragms.

Steel tub (box) girders are visually pleasing structures and are more expensive than usual steel plate girders because of fabrication cost. One of the main concerns in steel tubs or box girders in the State of Oregon is corrosion inside the girders. In the construction drawings, require inside surfaces of boxes or tubs (bottom flange, top flange, web and diaphragm) to be painted with a silver gray prime coat. Painting inside the tub (box) girders will prevent corrosion resulting from leakage thru the deck and condensation. Light color paint also increases illumination inside the tub (box) and eases detection of corrosion or cracks in steel members. Consider other corrosion protection measures as specified herein.

Whenever the end of steel members is cast inside concrete, the end of the member cast in concrete requires a three coat paint system as shown in *Figure 1.6.1.10C*.

Bridge Design Manual – June 2020
Oregon Department of Transportation
Section 1 – Design Standards

Fatigue Design Requirements – Design all welded and bolted connections for infinite fatigue design life. Do not use details category E or E' in any steel girder bridge (plate girders, tub girders or box girders) connections.

Skewed and Curved I-Girder Bridge Fit and Framing Arrangements

The contract documents should state the fit condition for which the cross-frames or diaphragms are to be detailed for the following I-girder bridges (*LRFD 6.7.2*):

- straight bridges where one or more support lines are skewed more than 20 degrees from normal;
- horizontally-curved bridges where one or more support lines are skewed more than 20 degrees from normal and with an L/R in all spans less than or equal to 0.03;
- horizontally-curved bridges with or without skewed supports and with a maximum L/R greater than 0.03.

where:

L = actual span length bearing to bearing along the centerline of the bridge (ft)

R = girder radius at the centerline of the bridge (ft)

Fit Condition – deflected girder geometry associated with a targeted dead load condition for which the cross-frames are detailed to connect to the girders.

Loading Condition Fit	Construction Stage Fit	Description
No-Load Fit (NLF)	Fully-Cambered Fit	The cross-frames are detailed to fit to the girders in their fabricated, plumb, fully-cambered position under zero dead load.
Steel Dead Load Fit (SDLF)	Erected Fit	The cross-frames are detailed to fit to the girders in their ideally plumb as-deflected positions under bridge steel dead load at the completion of the erection.
Total Dead Load Fit (TDLF)	Final Fit	The cross-frames are detailed to fit to the girders in their ideally plumb as-deflected positions under the bridge total dead load.

See [Skewed and Curved Steel I-Girder Bridge Fit \(Standalone Summary\)](#) and [Skewed and Curved Steel I-Girder Bridge Fit \(Full Document\)](#) for more information.

Recommended Fit Conditions for Straight I-Girder Bridges (including Curved I-Girder Bridges with L/R in all spans ≤ 0.03)

Square Bridges and Skewed Bridges up to 20 deg Skew			
	Recommended	Acceptable	Avoid
Any span length	Any		None
Skewed Bridges with Skew > 20 deg and $I_s \leq 0.30$ +/-			
	Recommended	Acceptable	Avoid
Any span length	TDLF or SDLF	-	NLF
Skewed Bridges with Skew > 20 deg and $I_s > 0.30$ +/-			
	Recommended	Acceptable	Avoid
Span lengths up to 200' +/-	SDLF	TDLF	NLF
Span lengths greater than 200' +/-	SDLF	-	TDLF & NLF

Recommended Fit Conditions for Horizontally Curved I-Girder Bridges ($(L/R)_{MAX} > 0.03$)

Bridge Design Manual – June 2020
Oregon Department of Transportation
Section 1 – Design Standards

Radial or Skewed Supports			
	Recommended	Acceptable	Avoid
$(L/R)_{MAX} \geq 0.2$	NLF	SDLF	TDLF
All other cases	SDLF	NLF	TDLF

- Detail for a Steel Dead Load Fit, unless the maximum L/R is greater than or equal to 0.2.
- When $(L/R)_{MAX} \geq 0.2$, detail for No-Load Fit, unless the additive locked-in force effects from Steel Dead Load Fit detailing are considered.

Bid items

Use following bid items for structural steel. Use horizontally curved steel (plate or box) girder bid item when the radius of horizontal curve on the structure is less than 1000ft.

- Steel Rolled Beam
- Steel Plate Girder
- Steel Box Girder
- Steel Plate Girder with haunch
- Trapezoidal Steel Box Girder with haunch
- Horizontally Curved Steel Plate Girder
- Horizontally Curved Steel Box Girder
- Specialty Bridges (tied arches, Cable Stayed)
- Structural Steel Maintenance

Details

See Standard Details *DET3600*, *DET3605* and *DET3610* for general details.

(1) Girder Spacing

Use wider girder spacing to reduce the number of lines of girders, which will reduce shop and field labor. Girder spacing between 10 feet to 14 feet generally works well. (10 feet' to 12 feet for spans less than 140 feet and 11 feet to 14 feet for spans greater than 140 feet)

(2) Girder Lengths

Make girder segments as long as possible to reduce the number of field splices. Maximum girder or girder field segment lengths without a field splice is normally 150 feet (depending upon cross section). There may be locations where girders lengths will be controlled by weight or access to the bridge site. Long girders may also require auxiliary lateral support during transportation. Consult with the Steel Bridge Standards Engineer for a maximum fabrication length.

It is typical to show an optional bolted field splice to allow the fabricator and contractor some flexibility in fabrication and transportation.

(3) Girder Depths

Girder depths, particularly for haunched girders, may be limited because of transportation constraints.

Use constant depth girders where possible.

(4) Girder Splices

Locate splices to avoid conflicts with wind bracing, diaphragms and/or intermediate stiffeners. Layout locations of all intermediate stiffeners, diaphragms and wind bracing to avoid conflicts with the flange cutoff

points (and possible splice locations).

Splices are a natural location to make changes in the flange size to eliminate flange welds. Maintain the same web thickness on each side of the splice. For flexural members, it is recommended that the smaller section at the point of splice be taken as the side of the splice that has the smaller calculated moment of inertia for the non-composite steel section.

(5) Girder Flanges

(a) General

Keep the number of changes in flange size to a minimum, as the cost of a butt weld will offset a considerable length of excessive flange area.

Constant width flanges enables the fabricator to order the flanges in multiple width plates which are more economical than universal mill plates. The shop flange splices can be made while the plates are in wide slabs and cut to widths simultaneously with multiple cutting torches.

Keep the number of flange splices to a minimum. It is recommended at least 500 pounds of steel be saved before adding a splice for a change of thickness in an average 20 inch wide flange. When the splice is a transition in width, the recommended saving is 800 pounds of steel.

The minimum size flange is 3/4" x 12". The minimum 3/4 inch flange thickness is to minimize the distortion of the flange due to welding of the flange to the web.

For longitudinal beams, limit the maximum change between adjacent plate thickness per *BDM 1.6.1(c)* and 6 inches in width, at both welded and bolted connection section changes.

(b) Compression Flanges

Make top flanges a constant width and thickness where possible. Minimizing the number of changes in the top flange will also facilitate easier deck forming.

It may not be prudent to minimize the top flange. Flange width affects girder stability during handling, erection, and deck placement. Keep the girder length (field section length) to flange width ratio below 85. The girder needs significant lateral load capacity to resist lateral transportation loads and lateral loads from deck overhang brackets and deck placements. Another side benefit of providing generous top flange is that the non-composite deflections are reduced.

(c) Tension Flanges

Make bottom flanges a constant width where possible. If a change in flange width is needed, make it at a bolted splice location.

Limit the maximum flange thickness to 3.0 inches. For flange thicknesses greater than 1-1/2 inches, limit the change in adjacent plate thicknesses to 3/4 inch. For flange thicknesses 1-1/2 inches or less, limit the change in adjacent plate thicknesses to 1/2 inch.

Generally, use a minimum flange width that is equal to the width of the flange resisting the maximum positive moment. Widen the flange as necessary in negative moment areas so the flange thickness will not exceed 3.0 inches at the bent.

(6) Girder Webs

Commonly used web plates are in the range of 48 inches to 96 inches.

Minimum web thickness is 1/2 inch.

Note that economy will often be served by the choice of a web plate of sufficient thickness that it does not require transverse stiffeners. In some cases thinner web plate with partial web stiffeners are economical. The labor to place and weld one foot of stiffener is equal to about 25 pounds of steel. Un-stiffened webs reduce fabrication, painting costs (for non-weathering steel) and flange sizes. Thicker webs are also helpful in reducing web distortion due to welding and in supporting deck overhang brackets for the deck placement.

Design web plates in 1/16 inch increments with a note that the contractor may increase the web thickness shown by 1/16 inch at no additional cost to the state. Minimize web transitions as the cost of a butt weld web splice often exceeds the cost of the added material between sections.

The cost of a square butt joint web splice is equal to about 800 pounds of steel per foot of splice. When web plates are over 80 feet long and constant thickness, give the fabricator an optional shop splice on the design plans. The most economical bid can then be prepared according to the mill length extras, market areas available, and transportation and handling costs.

Design Considerations

The following AASHTO/NSBA Steel Bridge Collaboration publications are available to aid in the design and fabrication of steel bridges. These publications can be downloaded from the AISC website at www.aisc.org/nsba/nsba-publications/aashto-nsba-collaboration/:

- G13.1-2019, Guidelines for Steel Girder Bridge Analysis
- G12.1-2016, Guidelines to Design for Constructability
- G1.4-2006, Guidelines for Design Details
- G1.2-2003, Design Drawing Presentation Guidelines
- G1.3-2002, Shop Detail Drawing Presentation Guidelines
- S2.1-2018, Steel Bridge Fabrication Guide Specification
- G4.1-2019, Steel Bridge Fabrication QC QA Guidelines
- G4.2-2006, Recommendations for the Qualification of Structural Bolting Inspectors
- G4.4-2006, Sample Owners Quality Assurance Manual
- G1.1-2000, Shop Drawing Approval Review/Approval Guidelines
- G2.2-2016, Guidelines for Resolution of Steel Bridge Fabrication Errors
- S8.1-2014, Guide Specification for Application of Coating Systems with Zinc-Rich Primers to Steel Bridges
- S8.2-2017, Specification for Application of Thermal Spray Coatings for Steel Bridges
- G9.1-2004, Steel Bridge Bearing Design and Detailing Guidelines
- S10.1-2019, Steel Bridge Erection Guide Specification

The following FHWA Steel Bridge Design Handbook, which includes 19 volumes of steel bridge design aids and 6 design examples, are also available as design aids and can be downloaded from the FHWA website at: www.fhwa.dot.gov/bridge/steel/pubs/hif16002/.

- Bridge Steels and Their Mechanical Properties–Volume 1
- Steel Bridge Fabrication–Volume 2
- Structural Steel Bridge Shop Drawings–Volume 3
- Structural Behavior of Steel–Volume 4
- Selecting the Right Bridge Type–Volume 5
- Stringer Bridges–Making the Right Choices–Volume 6
- Loads and Load Combinations–Volume 7
- Structural Analysis–Volume 8
- Redundancy–Volume 9
- Limit States–Volume 10
- Design for Constructability–Volume 11
- Design for Fatigue–Volume 12

- Bracing System Design–Volume 13
- Splice Design–Volume 14
- Bearing Design–Volume 15
- Substructure Design–Volume 16
- Bridge Deck Design–Volume 17
- Load Rating of Steel Bridges–Volume 18
- Corrosion Protection of Steel Bridges–Volume 19
- Design Example 1: Three-span Continuous Straight Composite Steel I-Girder Bridge
- Design Example 2A: Two-span Continuous Straight Composite Steel I-Girder Bridge
- Design Example 2B: Two-span Continuous Straight Composite Steel Wide-Flange Beam Bridge
- Design Example 3: Three-Span Continuous Horizontally Curved Composite Steel I-Girder Bridge
- Design Example 4: Three-Span Continuous Straight Composite Steel Tub Girder Bridge
- Design Example 5: Three-Span Continuous Horizontally Curved Composite Steel Tub-Girder Bridge

1.6.1.1 Materials and Identification

(1) General

Identify all steel by grade on the contract plans.

Provide structural steel for bridges conforming to ASTM A709 (AASHTO M270). These specifications include Grades 36, 50, 50W, HPS 50W, and HPS 70W. ASTM A709 steel specifications are written exclusively for bridges wherein supplementary requirements for Charpy V-Notch Impact tests are mandatory. Grade HPS 70W steel has recently been developed that provides high strength, enhanced durability and improved weldability. Specify Grade HPS 50W and HPS 70W to be “Quenched and Tempered” in the contract document and for thermo-mechanical control processed require the contractor to provide test samples at both ends of each rolled plate. Plates that pass the required test are acceptable for fabrication.

Provide structural Steel for steel piling, metal sign structures and other incidental structures conforming to ASTM A36, ASTM A572 or ASTM A588. Incidental structures include luminaire and traffic signal supports, bridge metal rails and metal rail posts, guardrail connections, earthquake restraints, bridge deck expansion joints, fencing post connections, etc. Merchant quality steel (non-spec) is used in items such as catch basin frame, catch basin, deck drain grate, manhole rungs and steps, access hole cover, guardrail spacer blocks, shims, anchor bolt plate embedded in concrete, etc. where a high degree of internal soundness, chemical uniformity or freedom of surface defects are not required. Acceptance of such items is on the basis of visual inspection.

ASTM A36, A572, or A588 may be used for structural steel for bridges provided the supplementary Charpy V-Notch Impact test requirements are included in the Special Provisions. If Charpy V-Notch Impact tests are required for ASTM A36, A572 or A588 structural steel, use the supplementary requirements of ASTM A709.

Do not use A709 (Grades 36, 50, 50W) steels for plates thicker than 3 inches, nor butt welds in tension members over 3 inches. Limit plate thickness for HPS 50W and HPS 70W to 2 inches. Consult with the Steel Bridge Design Standards Engineer for specific project needs.

Specify ASTM A709 Grade 50 steel for all structures that require yield strengths between 36 ksi and 50 ksi and are to be painted or galvanized.

(2) Weathering Steel

Through several cycles of wetting and drying, the surface of the steel develops a tight oxide coating (patina)

that provides its own corrosion resistant surface finish. Eliminating the need for painting results in minimal future maintenance and lower life cycle costs.

Consider the use of ASTM A709 Grade 50W, HPS 50W, HPS 70W & 100W weathering steel with some caution. Avoid weathering steel in some environmental areas, locations or conditions. There have been cases where the use of this material in improper locations or under improper conditions has resulted in less than desirable performance of the structure. Conditions or locations of concern include:

Environment

- Marine Coastal areas
- Frequent high rainfall, high humidity or persistent fog
- Industrial areas where concentrated chemical fumes may drift onto the structure
- Welded, riveted, or bolted built up structural member (boxes or plate girders)

Location

- Grade separations in tunnel like conditions
- Low level water crossings
- Conditions that do not allow for the drying of the steel necessary to develop a good patina.

Review the [FHWA Technical Advisory T 5140.22, "Uncoated Weathering Steel in Structures"](#), for location restrictions and recommended detailing practices.

One of the significant advantages of HPS 50W, HPS 70W steel is its enhanced weathering capacity over Grades 50W and 70W steels. Weathering capability is calculated using the heat analysis compositions in an equation to calculate an atmospheric corrosion resistance index, "I", in ASTM G101 "Estimating the Atmospheric Corrosion Resistance of Low-Alloy Steels." In general, a corrosion index of 6.5 is considered a minimum to be classified as HPS. The higher the index, "I", the more corrosion resistant is the steel. Do not use Grade 70W steel.

(3) Check Samples

Tension members and elements that require notch toughness check samples are to be clearly identified on the plans. Check samples are required for cross-frame members on curved steel girders.

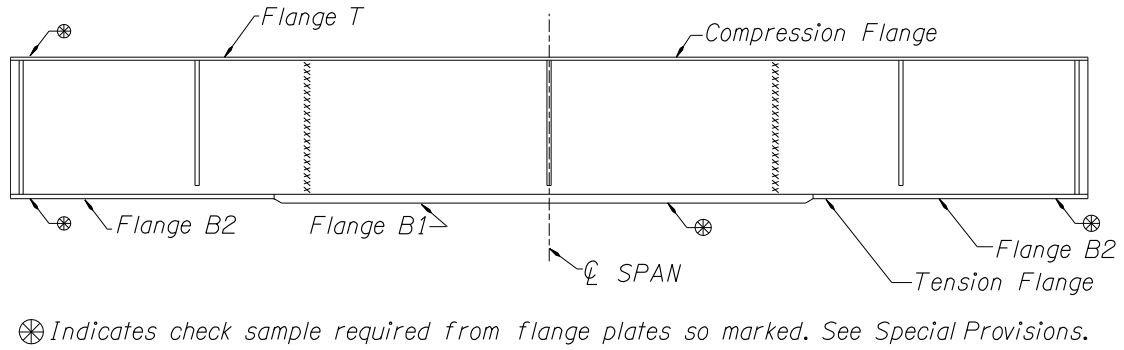

Figure 1.6.1.1A

(4) Fracture Critical Members

Clearly identify fracture-critical members on the plans.

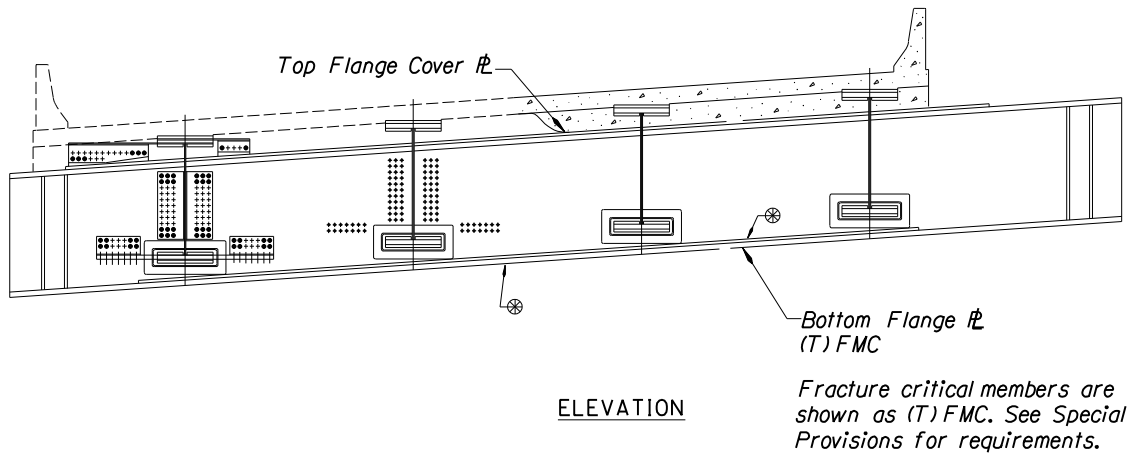

Figure 1.6.1.1B

1.6.1.2 Shop Lengths of Welded Girders

Locate field splices in welded steel beams so as not to exceed the following shop lengths and mass (All field splices shall be bolted):

- Bridge site is readily accessible....150 feet (longer girders have been fabricated and hauled to project sites, however contact fabricators and Bridge Engineering Section if project need requires girder segments longer than 150 feet).
- Bridge site is not readily accessible....125 feet
- Fabricators are limited to their shop crane sizes. Contact fabricators in the State of Oregon for project specific needs and requirements.

1.6.1.3 Intermediate Cross-Frames

Design

If needed, provide and design cross-frames for all stages of construction and the final condition.

For skewed (>20°) and curved I-girder bridges:

- See *LRFD C6.7.4.2* for discussion about beneficial framing arrangements in skewed and curved I-girder bridges to alleviate detrimental transverse stiffness effects.
- It is recommended to offset the first intermediate cross-frame placed normal to the girders adjacent to a skewed support:

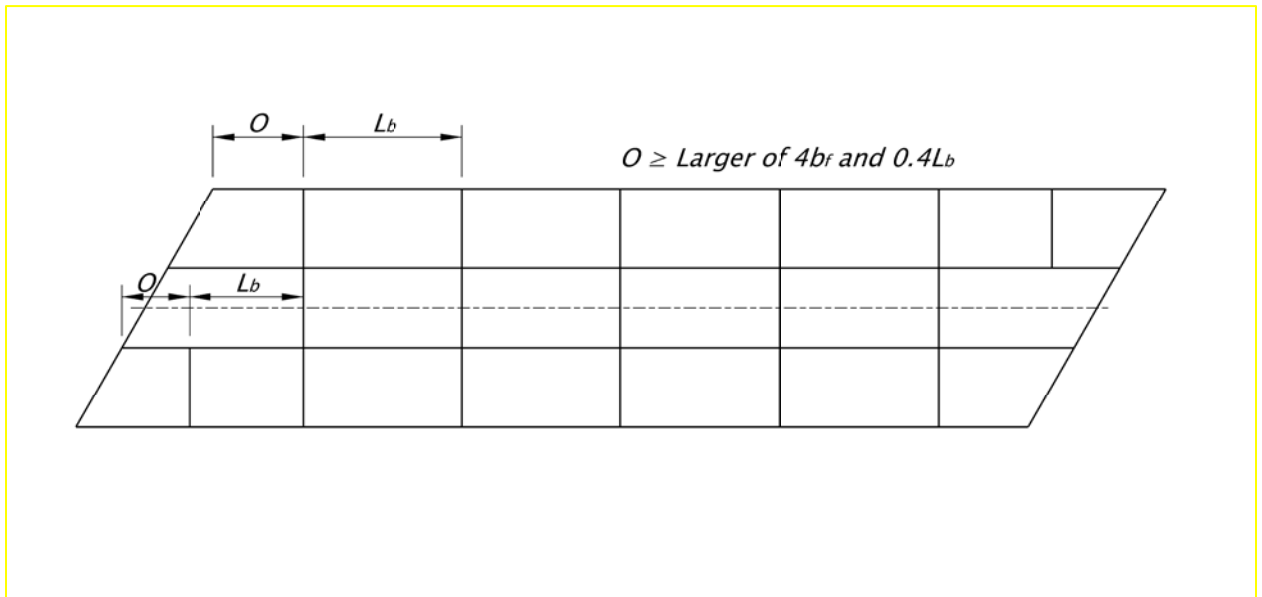

Figure 1.6.1.3

- Framing of a normal intermediate cross-frame into or near a bearing location along a skewed support line is strongly discouraged unless the cross-frame diagonals are omitted.
- At skewed interior bents and end bents, place cross-frames along the skewed bearing line, and locate intermediate cross-frames greater than or equal to the recommended minimum offset from the bearing lines.
- For curved I-girder bridges, provide contiguous intermediate cross-frame lines within the span in combination with the recommended offset at skewed bearing lines.

Detailing

In choosing between intermediate cross-frames of "K" or "X" form, in general use the "X" form when the ratio of the beam spacing to the frame depth is less than 2 and the "K" form when it is greater than 2. Consider a solid plate diaphragm when the depth of the frame approaches 3 feet or less.

Also consider maintenance requirements in the cross-frame design. Providing adequate clearance for sandblasting and painting is recommended. Avoid inaccessible areas. It may also be necessary to provide for maintenance walkways and/or utilities through the cross-frames.

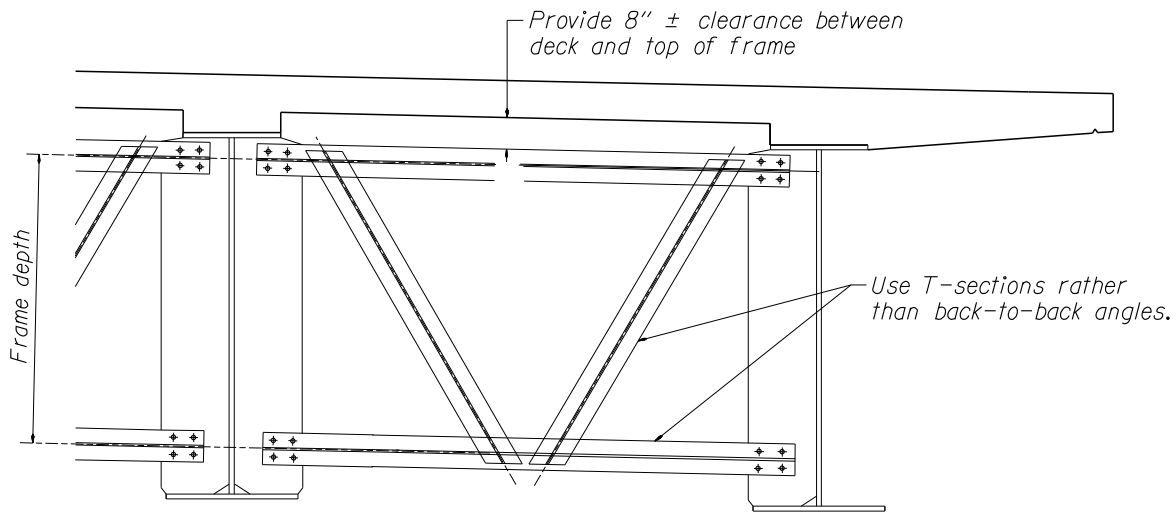

Seal all weld terminations and unwelded connections of crossframes with structural steel caulking from QPL, typical.

Figure 1.6.1.3A

Rigidly connect cross-frames to the top and bottom flanges to prevent web distortions and cracking. Weld stiffeners to compression and tension flanges as shown on [Figures 1.6.1.3B, 1.6.1.3C and 1.6.1.3D](#). Stop ends of welds about 1/4 inch away from the edge (snipe, clip, etc.) to avoid a poor quality weld termination.

Where two adjacent plate girders have significant differential deflection, such as the first row of cross-frame from the end bents, do not use the "K" or "X" type of cross-frames. Use details shown on [Figure 1.6.1.13B](#). Check fatigue requirements of all welded connections.

Provide intermediate cross-frames between the box girders. Submit a request for a design deviation to the State Bridge Engineer when a project requires omitting intermediate cross-frames or diaphragm between steel tub or box girders.

Connection Plates for Bracing Members - Cope diaphragm connection plates, which are welded to both the web and flange of a plate girder, a minimum of 1-1/2 inches to prevent intersection of the two welds. Avoid lateral connection plates for lateral bracing which will be connected to the web of the plate girder or box girders. Bolt lateral connection plates to the flange of the steel girder. Cope lateral connection plates to be clear of any transverse web stiffener or diaphragm connection plate.

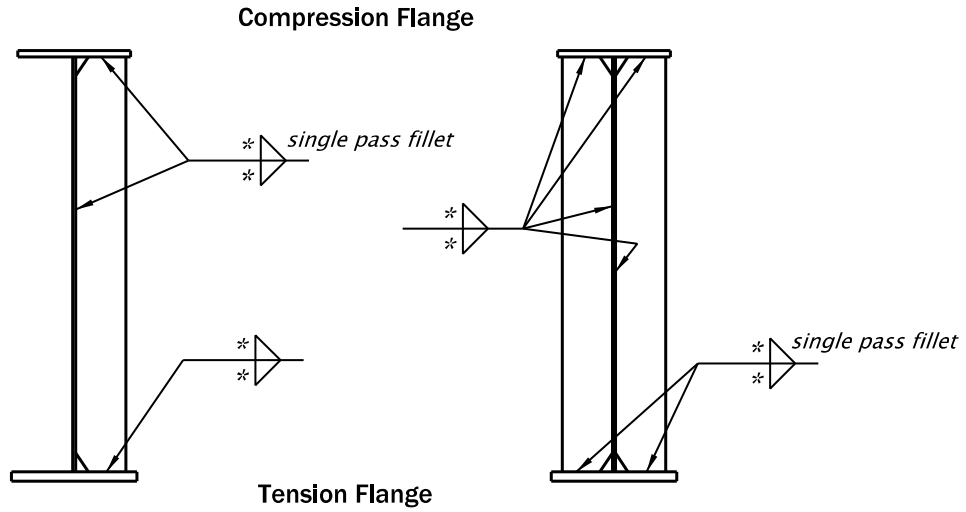

INTERMEDIATE EXTERIOR

INTERMEDIATE INTERIOR

** Size fillet welds in accordance with AASHTO LRFD minimum welds sizes shall not be less than 1/4" for $t \leq 3/4$ " or 3/16" for $t > 3/4$ ".*

Compression and Tension flanges reverse near interior bent of continuous girder.

Seal all weld terminations and unwelded connections of crossframes and stiffeners with structural steel caulking from QPL, typical.

TRANSVERSE CONNECTION PLATES

Figure 1.6.1.3B

CURVED GIRDER

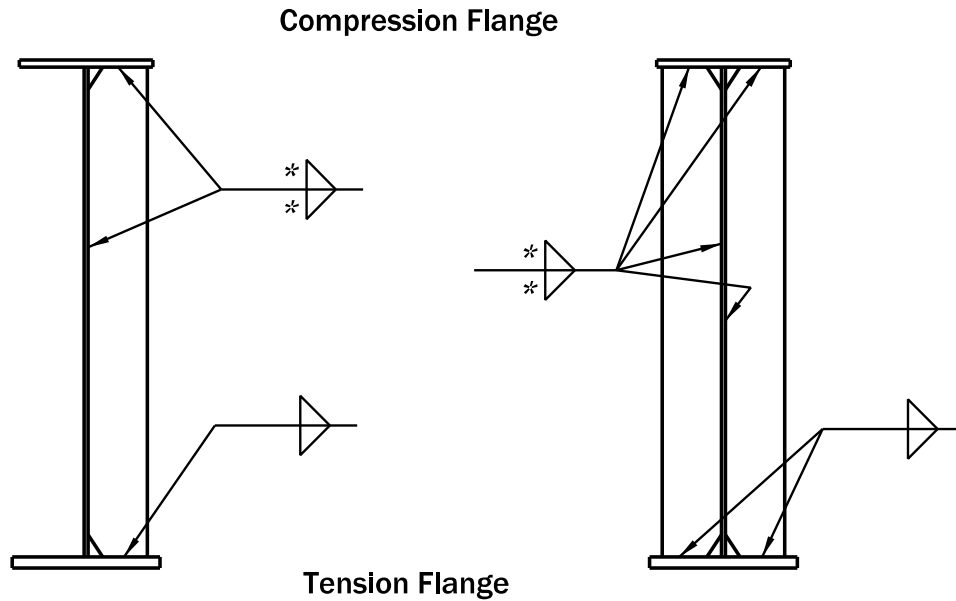

INTERMEDIATE EXTERIOR

INTERMEDIATE INTERIOR

Compression and Tension flanges reverse near interior bent of continuous girder.

Seal all weld terminations and unwelded connections of crossframes with structural steel caulking from QPL, typical.

TRANSVERSE CONNECTION PLATES

Figure 1.6.1.3C

Bridge Design Manual – June 2020
Oregon Department of Transportation
Section 1 – Design Standards

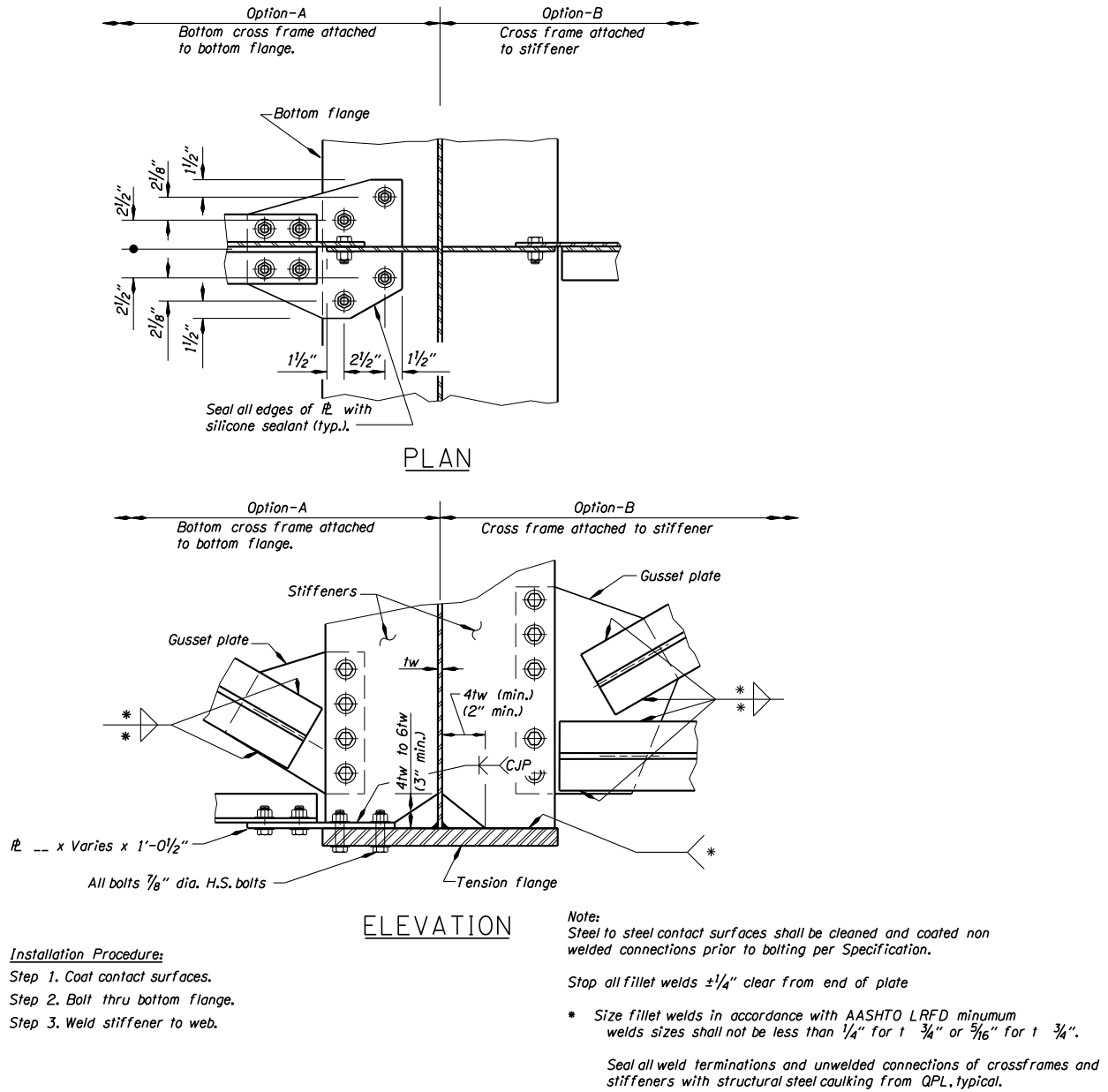

For stiffener thickness connecting to tension flange ≤ 1/2". See figure 1.2.1.3B

WELDED BRACKET DETAILS

Figure 1.6.1.3D

1.6.1.4 Intermediate Web Stiffeners

Note that economy will often be served by the choice of a web plate of sufficient thickness that it does not require transverse stiffeners.

Where transverse intermediate stiffeners are used, provide them on both faces of the webs of interior girders and on the interior faces, only, of exterior girders.

Rigidly connect the stiffeners to the compression portions of the flanges. Stiffeners may be welded to compression flanges. Ends welds about 1/4" away from the edge (snipe, clip, etc.) to avoid a poor quality weld termination.

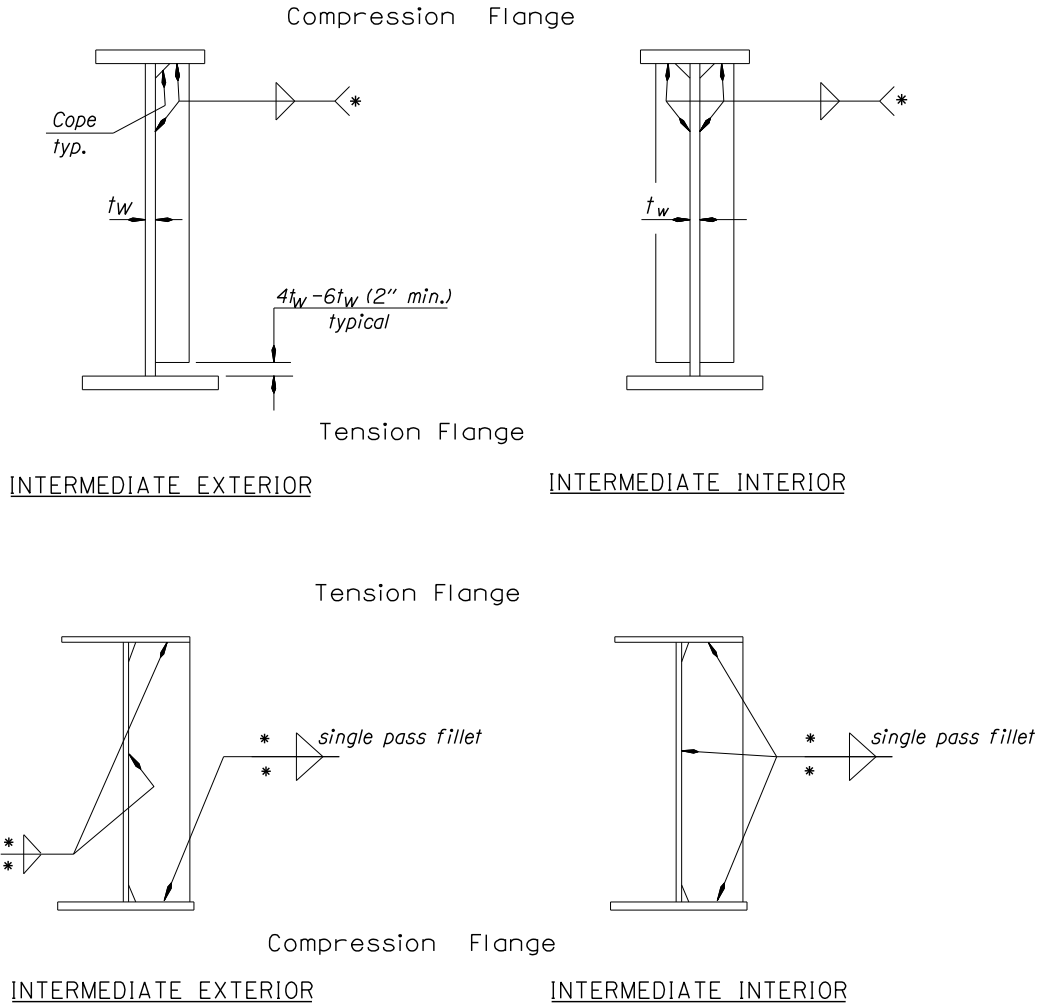

- For stiffener thickness connecting to tension flange $\leq 1/2"$. See figure 1.2.1.3B
- * Size fillet welds in accordance with AASHTO LRFD. Minimum weld sizes not less than $1/4"$ for $t \leq 3/4"$ or $5/16"$ for $t > 3/4"$.
 - * Compression and tension flanges reverse near interior bents for continuous girder.
 - * Seal all weld terminations of stiffeners with structural steel caulking from QPL, typical.

INTERMEDIATE WEB STIFFENERS

Figure 1.6.1.4A

1.6.1.5 Bearing Stiffeners

Bearing stiffeners and the web act as a column section, transferring loads from the superstructure to the substructure. In combination with the end frames, they also transfer lateral loads from the superstructure to the substructure. **Minimum size of fillet weld is the minimum specified in BDM 1.6.2.2. Select bearing stiffener widths in increments of 1/2 inch.**

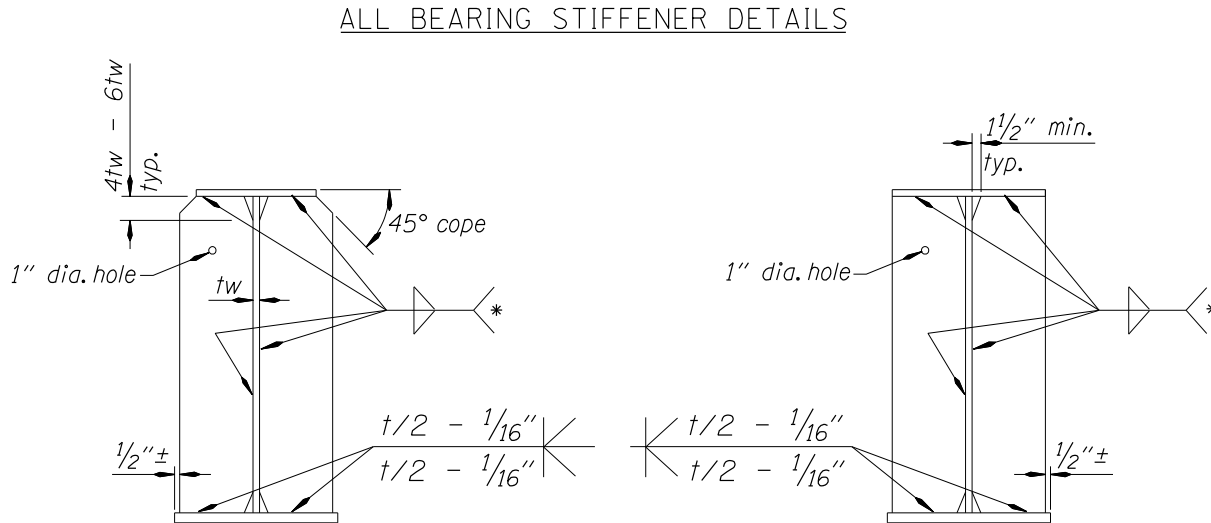

Figure 1.6.1.5A

Limit bearing stiffeners skew angle at end bents or interior bents to the values shown in Figure 2.3 of the AWS D1.5 for bearing stiffeners to web connection. Discard the footnotes of the figure which permits angles less than 60 degrees. When the skew angle exceeds limit shown on the Figure, use bent plates.

1.6.1.6 Cross-Frames at Bents

Cross-frames at bents are more critical to transfer seismic forces from the superstructure to the substructure. One solution is to use detail *Figure 1.6.1.6A* with a W shape beam between the girders at the top of the cross-frame. Welded studs are added to the top flange of these W shape beams to provide the lateral resistance.

If a joint system is required for a cross-frame at end bents, it may be necessary to use details similar to cross-frames at continuous beam interior bents. See *Figure 1.6.1.6A*.

Diaphragms or cross-frames are required along skewed interior bents and end bents.

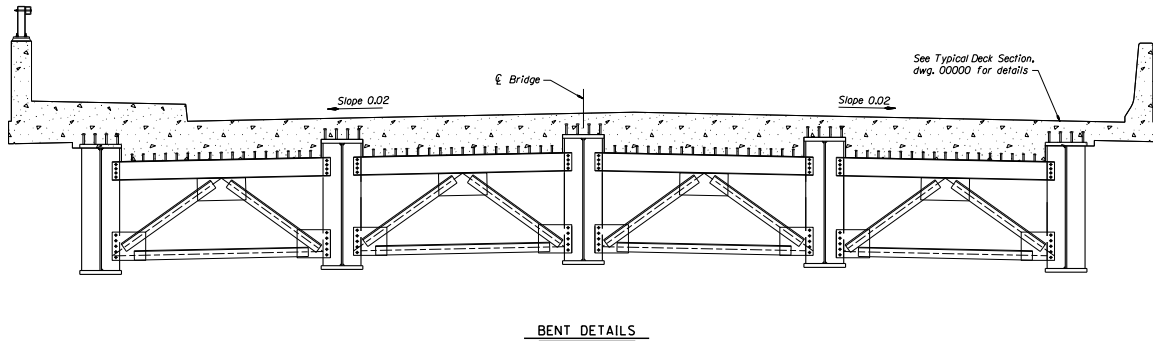

Figure 1.6.1.6A

It is desirable to have all cross-frame member centerlines intersecting at a common point. But, it is often easier to design for the eccentric loads in the connection than to get a common intersection point of the member centerlines.

1.6.1.7 Composite Action and Flange Shear Connectors

Provide shear connectors in all portions of continuous spans, positive or negative moment. Old practice was to not use concrete reinforcement to increase the moment capacity of composite girders in the negative moment areas. However, for deflection and moment calculations include longitudinal reinforcing steel in the composite section properties of the girder in the negative moment areas.

Extend shear connectors at least 1 inch above the mid depth of the deck. Generally, the deck build up on steel girders is constant except for bridges with variable cross-slopes (super elevation) along the bridge. However the top flange plate thicknesses may vary. Consider the effect of top flange thickness variation and bridge deck super elevations when checking the shop drawings or specifying the shear connector's length. The advantages of longer shear connectors are in distributing load to larger area of the bottom mat reinforcing steel when a girder fails in fatigue. The concrete deck will distribute a portion of the unsupported load of the failed girder to adjacent girder/girders.

Where transverse deck reinforcing is to be placed skewed with the centerline of the girder, the studs shall be placed in rows parallel to the direction of the deck steel.

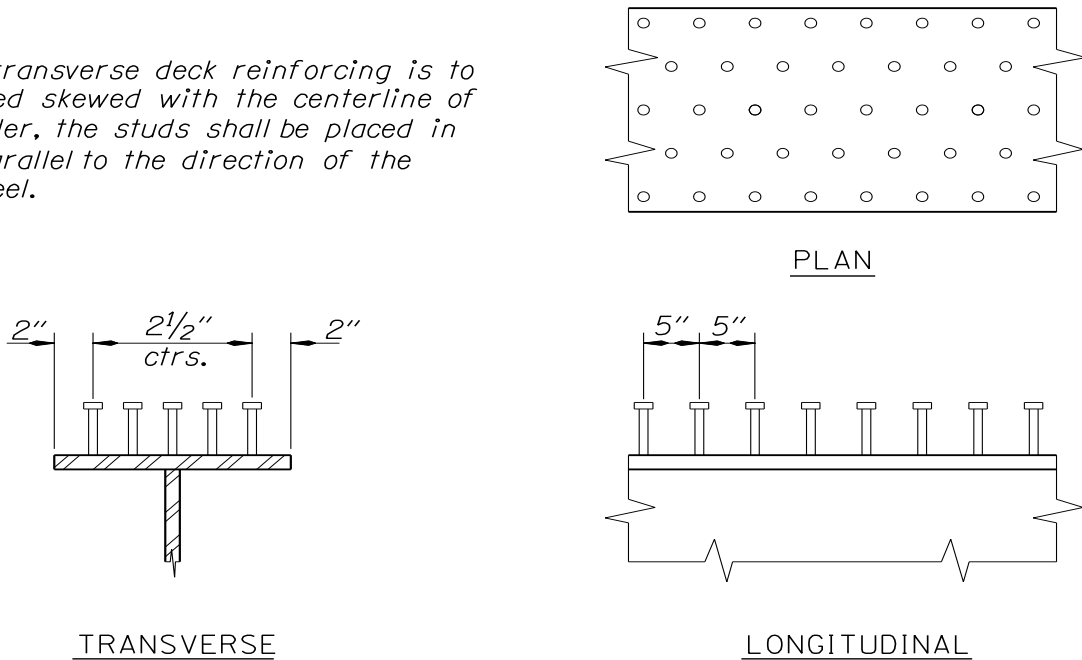

MINIMUM SHEAR CONNECTOR SPACING
Max. shear connector spacing (longitudinal = 2'-0")

Figure 1.6.1.7A

1.6.1.8 Beam Camber

(1) Beam Camber, General

Steel beams are cambered to compensate for dead load, shrinkage deflections and gradelines. The final position of the bottom flange is either flat or follows the grade, except in a sag vertical curve. Do not place a final negative camber in a beam. Profile grades can be incorporated into the camber by either added camber in the beam or by varying the deck flange build-ups along the beam. Sag vertical curves always require flange build-ups. Consider the superelevation of the deck in the design of minimum flange build-ups.

Slope adjustment or build-up for straight girders on curved roadways must also be considered. Deck grades are based on the roadway centerline and straight girders are offset at midspan from the centerline. As a result, the adjustment is the superelevation times the midspan offset. Additional beam camber at midspan or additional build-up at the ends will be required. See [Figure 1.6.1.8A](#).

In addition to girder deflections, show girder rotations at bearing stiffeners. This will allow shop plan detailers to compensate for rotations so that bearing stiffeners will be vertical in their final position.

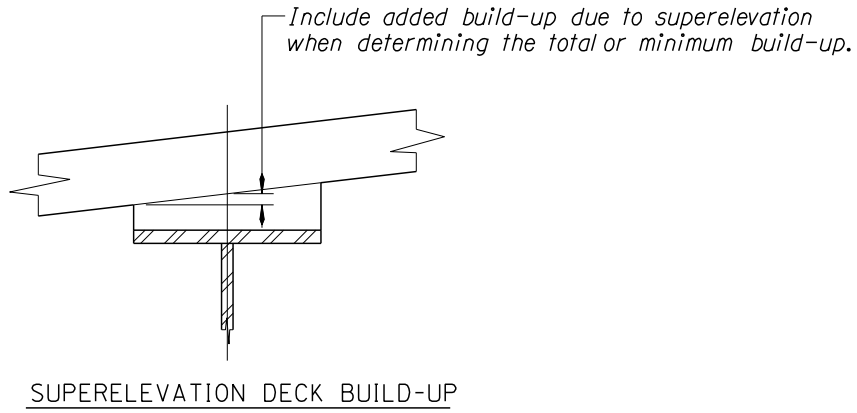

Figure 1.6.1.8A

Sketches of the camber options for simple spans are shown in *Figures 1.6.1.8B through 1.6.1.8D*.

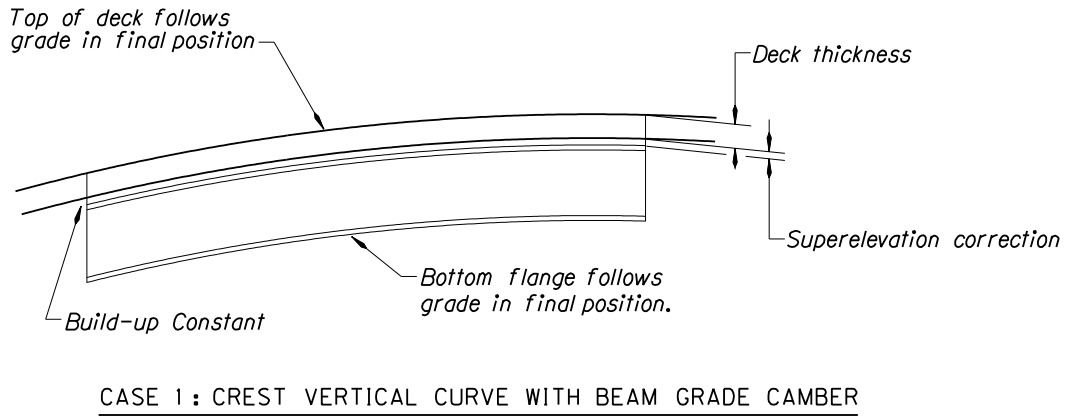
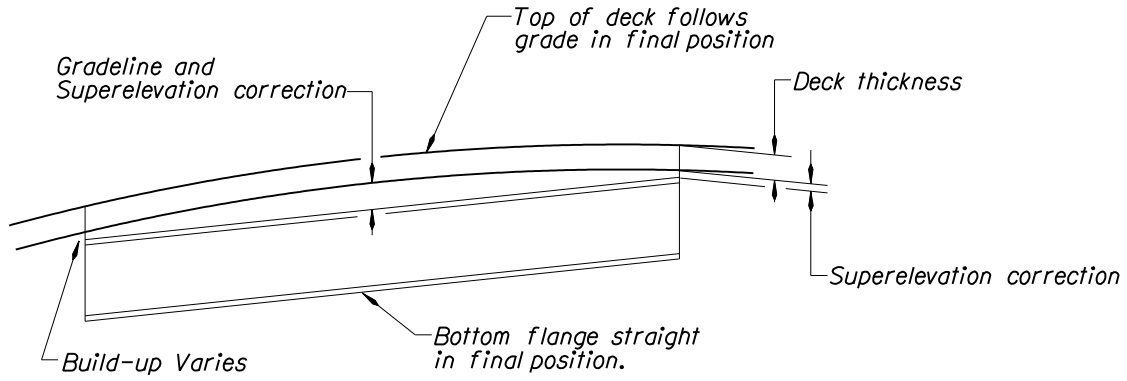
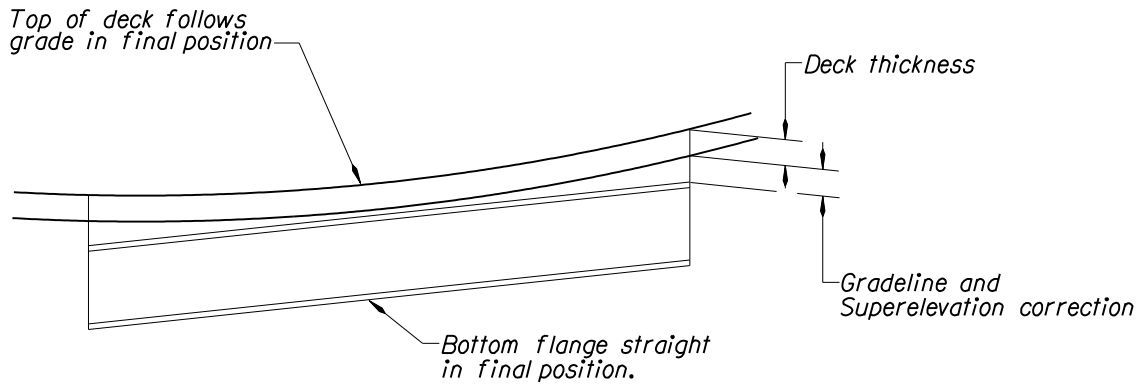

Figure 1.6.1.8B



CASE 2 : CREST VERTICAL CURVE WITH BUILD-UP FOR GRADE CAMBER

Figure 1.6.1.8C



CASE 3 : SAG VERTICAL CURVE WITH BUILD-UP FOR GRADE CAMBER

Figure 1.6.1.8D

(2) Shrinkage Camber

Bridge deck shrinkage has a varying degree of effect on superstructure deflections. The designer shall use some judgment in evaluating this effect on camber. Bridge deck shrinkage should be the smallest portion of the total camber. It has greater influence on shallower girder sections, say rolled beams. Simple spans will see more effect than continuous spans. For calculation, apply a shrinkage strain of 0.0002 to the long-term composite section using $3n$. Tests have indicated that the unit shrinkage of the slab in composite beams (i.e., the shrinkage strain adjusted for long-term relaxation effects) may be taken equal to 0.0002.

The steel stresses in straight simple spans may be approximated by considering the composite cross-section as an eccentrically loaded column with a load of $0.0002 E_c n A_c$ applied at the centroid of the slab and using $n = E_s/E_c$.

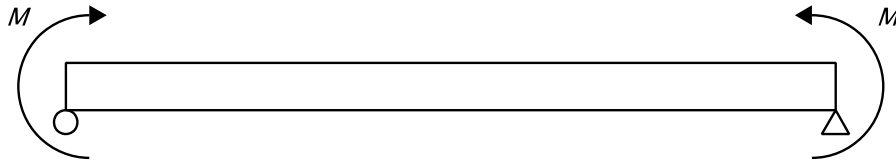

Figure 1.6.1.8E

M = moments applied to structure due to concrete shrinkage
 $= (0.0002 \text{ in/in}) E_c A_c Y_t$ in kip-inches

Where:

- E_c = Modulus of elasticity of concrete (ksi)
- f'_c = Concrete Strength (psi)
- A_c = total area of concrete (in²)
- Y_t = distance from cg of the deck to the cg of the composite section *. (inches).

* Note: Use $3n$ for modular ratio in calculating section properties.

Example of a two span bridge with two different girder sections:

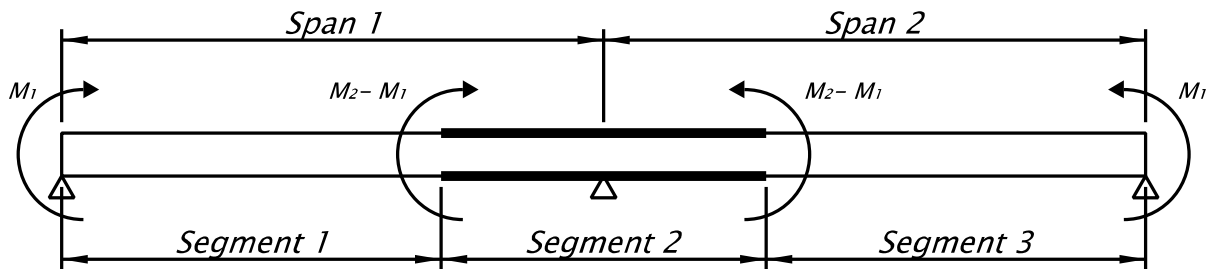

Figure 1.6.1.8F

For two span bridge, the magnitude of the applied moments is equal to the compression force times the distance from the mid-depth of the deck to the c.g. of the composite section for that segment. Where two segments join the applied moment is the difference between the calculated moments for each segment.

The deflections of the first pour are based on the whole girder acting non-composite, then the deflections of the second pour are based on the area of the first pour acting compositely with the rest of the girder non-composite and so on until the last pour. The deflections due to each pour sequence are added together and only the total is shown in the camber table.

For structures requiring close tolerances on girder cambers, refined analysis of shrinkage effects utilize structural analysis software such as MIDAS Civil may also be used provided they are based on the same concrete shrinkage strain.

(3) Camber Diagrams

Show the following data for steel beam camber on the contract drawings:

Grade line camber.....	_____
Dead load camber.....	_____
Superimposed Dead load camber.....	_____
Shrinkage camber.....	_____
Total Camber.....	_____
Camber due to weight of steel beam and diaphragm...	_____

Bridge Design Manual – June 2020
Oregon Department of Transportation
Section 1 – Design Standards

Camber diagram examples:

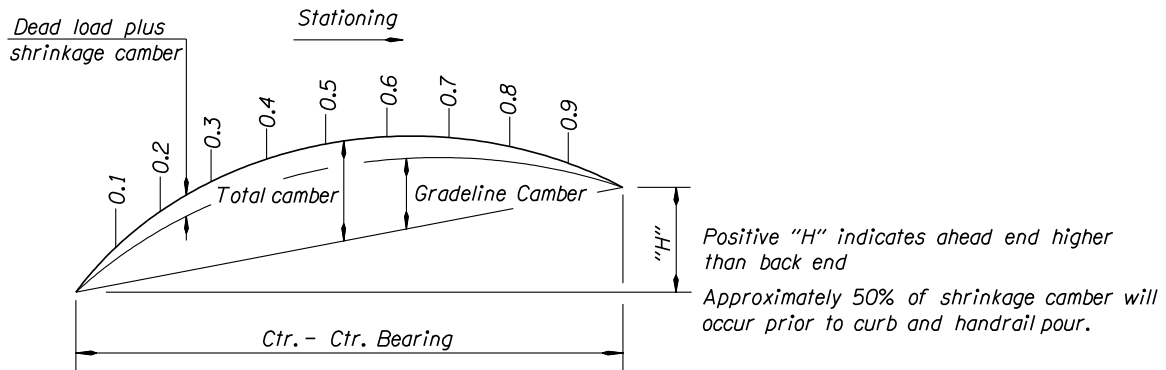
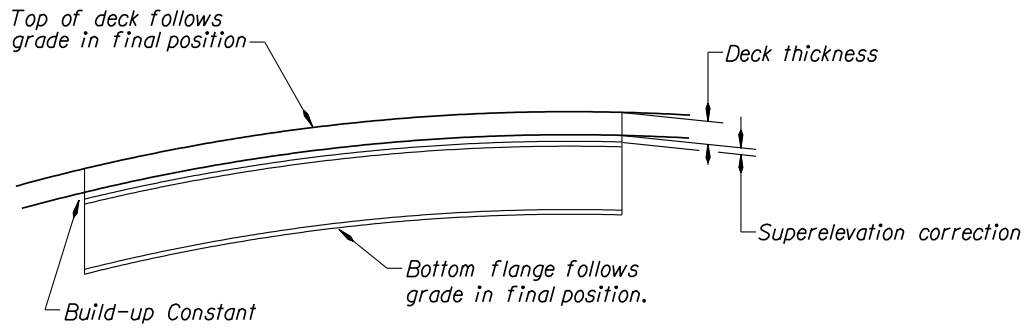

GIRDER CAMBER											
Span	Item	Camber									H inches
		0.1 Pt.	0.2 Pt.	0.3 Pt.	0.4 Pt.	0.5 Pt.	0.6 Pt.	0.7 Pt.	0.8 Pt.	0.9 Pt.	
1	Beam Dead Load + Diaphragms	5/8"	1"	1 3/8"	1 1/2"	1 3/8"	1 1/8"	3/4"	3/4"	1/16"	+16 3/8"
	Deck Dead Load + Form	1 3/8"	2 1/2"	3 3/16"	3 1/4"	3 3/16"	2 3/16"	1 3/8"	1 1/16"	1/4"	
	Sidewalk, Rail & WS Dead Load	3/8"	5/8"	1 3/16"	7/8"	1 3/16"	1 5/16"	5/8"	5/16"	1/16"	
	Shrinkage	5/8"	1"	1 1/4"	1 1/4"	1 1/8"	1"	3/4"	1/2"	1/4"	
	Sub Total	3"	5 1/8"	6 5/8"	6 7/8"	6 3/8"	5 1/8"	3 1/2"	1 7/8"	5/8"	
	Gradeline	3/8"	3/4"	1"	1 1/8"	1 1/4"	1 1/8"	1"	3/4"	3/8"	
	Total	3 3/8"	5 7/8"	7 5/8"	8"	7 5/8"	6 1/4"	4 1/2"	2 5/8"	1"	
2	Beam Dead Load + Diaphragms	1/16"	1/4"	5/8"	7/8"	1 1/16"	1 1/16"	5/8"	5/16"	1/16"	+7 3/8"
	Deck Dead Load + Form	1/8"	3/4"	1 5/8"	2 7/16"	3 1/16"	3 1/4"	1 5/8"	1 3/16"	1/8"	
	Sidewalk, Rail & WS Dead Load	1/16"	1/4"	1/2"	1 3/16"	7/8"	1 3/16"	1/2"	1/4"	1/16"	
	Shrinkage	-1/4"	-3/8"	-3/8"	-3/8"	-3/8"	-1/4"	-1/8"	-1/8"	0	
	Sub Total	0	7/8"	2 3/8"	3 3/4"	4 1/4"	3 7/8"	2 3/4"	1 1/4"	1/4"	
	Gradeline	5/8"	1 1/4"	1 5/8"	1 3/4"	1 7/8"	1 3/4"	1 5/8"	1 1/4"	5/8"	
	Total	5/8"	2 1/8"	4"	5 1/2"	5 1/8"	5 5/8"	4 3/8"	2 1/2"	7/8"	

Figure 1.6.1.8F

Bridge Design Manual – June 2020
Oregon Department of Transportation
Section 1 – Design Standards

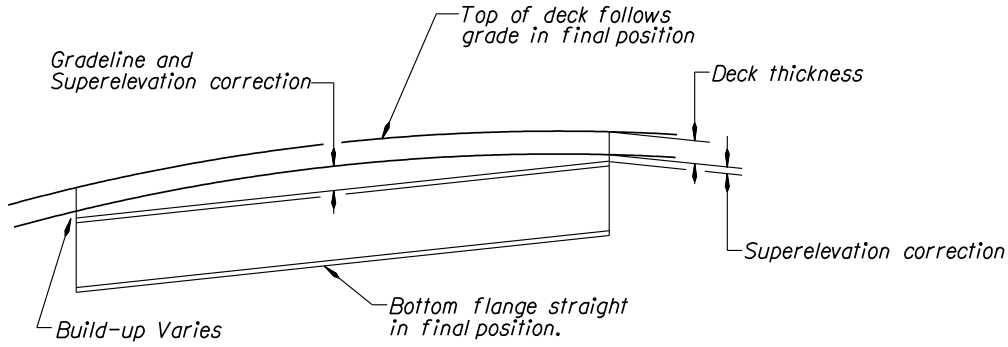

CREST VERTICAL CURVE WITH BUILD-UP FOR GRADE CAMBER

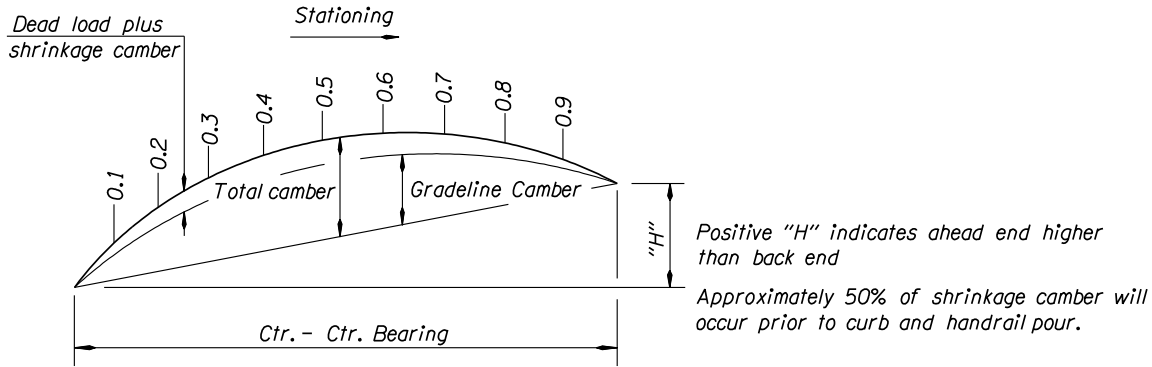

GIRDER CAMBER											
Span	Item	Camber									H inches
		0.1 Pt.	0.2 Pt.	0.3 Pt.	0.4 Pt.	0.5 Pt.	0.6 Pt.	0.7 Pt.	0.8 Pt.	0.9 Pt.	
1	Beam Dead Load + Diaphragms	5/8"	1"	1 3/8"	1 1/2"	1 3/8"	1 1/8"	3/4"	3/4"	1/16"	+ 16 3/8"
	Deck Dead Load + Form	1 3/8"	2 1/2"	3 3/16"	3 1/4"	3 3/16"	2 3/16"	1 3/8"	1 1/16"	1/4"	
	Sidewalk, Rail & WS	3/8"	5/8"	13/16"	7/8"	1 3/16"	15/16"	5/8"	5/16"	1/16"	
	Shrinkage	5/8"	1"	1 1/4"	1 1/4"	1 1/8"	1"	3/4"	1/2"	1/4"	
	Sub Total	3"	5 1/8"	6 5/8"	6 7/8"	6 3/8"	5 1/8"	3 1/2"	1 7/8"	5/8"	
	Gradeline	None	None	None	None	None	None	None	None	None	
	Total	3"	5 1/8"	6 5/8"	6 7/8"	6 3/8"	5 1/8"	3 1/2"	1 7/8"	5/8"	
2	Beam Dead Load + Diaphragms	1/16"	1/4"	5/8"	7/8"	1 1/16"	1/16"	5/8"	5/16"	1/16"	+ 7 3/8"
	Deck Dead Load + Form	1/8"	3/4"	1 5/8"	2 7/16"	3 1/16"	3 1/4"	1 5/8"	13/16"	1/8"	
	Sidewalk, Rail & WS	1/16"	1/4"	1/2"	13/16"	7/8"	13/16"	1/2"	1/4"	1/16"	
	Shrinkage	-1/4"	-3/8"	-3/8"	-3/8"	-3/8"	-1/4"	-1/8"	-1/8"	0	
	Sub Total	0	7/8"	2 3/8"	3 3/4"	4 1/4"	3 7/8"	2 3/4"	1 1/4"	1/4"	
	Gradeline	None	None	None	None	None	None	None	None	None	
	Total	0	7/8"	2 3/8"	3 3/4"	4 1/4"	3 7/8"	2 3/4"	1 1/4"	1/4"	

Figure 1.6.1.8G

1.6.1.9 Deck Pouring Sequence

Deck pouring sequences for continuous steel spans must be developed according to the span and deflection characteristics of the particular bridge.

The general principal is to first place the sections that are outside of the negative moment zones. Subsequent placements may produce negative flexure in the previously placed sections (See *LRFD 6.10.3.7* for commentary). Provide minimum negative flexure slab reinforcement per *LRFD 6.10.3.7* as needed. Set retarding admixture may be required to reduce excessive induced stresses in adjacent spans placed sequentially.

Any changes to the pouring sequence during construction must be analyzed by the Contractor's Engineer to determine any effects on stresses and camber. This review will need to be completed early in the process, because it may affect the beam fabrication.

The following steps are a general rule for pouring sequence of continuous steel bridges:

1. Pour (1) consists of all positive moment areas along the bridge which will not cause upward deflection on other span/s. No waiting period is required between these spans.
2. Pour (2) consists of multiple separate placements of all positive moment areas of spans that cause upward deflection on other spans. The wait period between these span placements is a minimum of three days after the last pour (1) ended and reaches 70% of final strength. If multiple spans are placed sequentially in the same pour, set retarding admixture may be required to reduce excessive induced stresses in adjacent spans.
3. Pour (3) consists of all negative moment areas. The pour can be placed a minimum three days after the last pour (2) ended.

The pouring sequence of three span continuous balanced bridges is shown below:

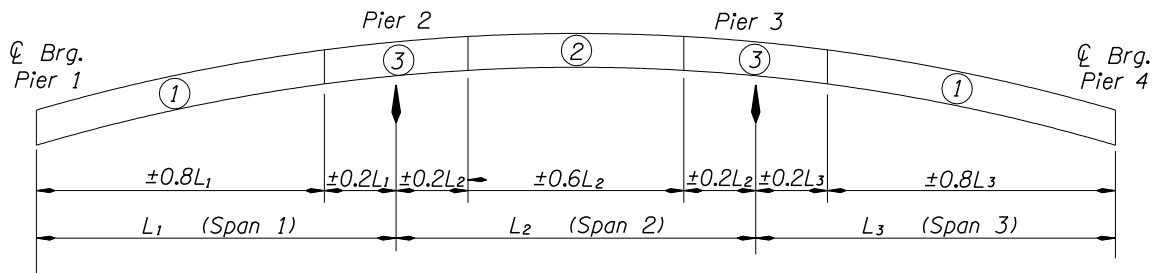

DECK POURING SEQUENCE - STEEL SPANS

POURING SEQUENCE

1. Make Pours (1) . May be made simultaneously or separately as desired by the contractor.
2. After a minimum of 3 days after the completion of Pour (1) and concrete has reached 70% full strength. Make Pour (2) .
3. After minimum of 3 days after completion of Pour (2), make Pours (3) . Pours (3) may be made simultaneously or separately.

Note: Deck concrete shall be placed and screeded parallel to bents.

Figure 1.6.1.9A

The deck pouring sequence for bridges designed continuous for live load consists of two pours. Pour (1) for all positive moment areas except for closure pours. Pour (2) consists of all closure pours at interior and/or end bents a minimum of three days after pour (1).

1.6.1.10 End Bents Detailing

It is desirable to eliminate end bent joints or make construction jointless to protect the girder steel from leaking joints.

Use the extended deck detail or semi integral abutments similar to *Figures 1.6.1.10A* or *1.6.1.10B*.

Use the integral abutments when geometry and span length allow. Show a painted section at the ends of plate girders. On jointless bridges paint the end of the girder for a length of 1'-0" outside the concrete interface and 4 inches inside the concrete interface. See *Figure 1.6.1.10C*.

Where joints cannot be avoided, show a paint detail at the end of plate girders. Paint the end of the girder for a length at least 1.5 times the depth of the girder and all attachments within this limit. See *Figure 1.6.1.10D*. The paint color is to match the developed weathering steel patina 2.5 years after completion of the bridge construction. See *Figure 1.6.1.10D*.

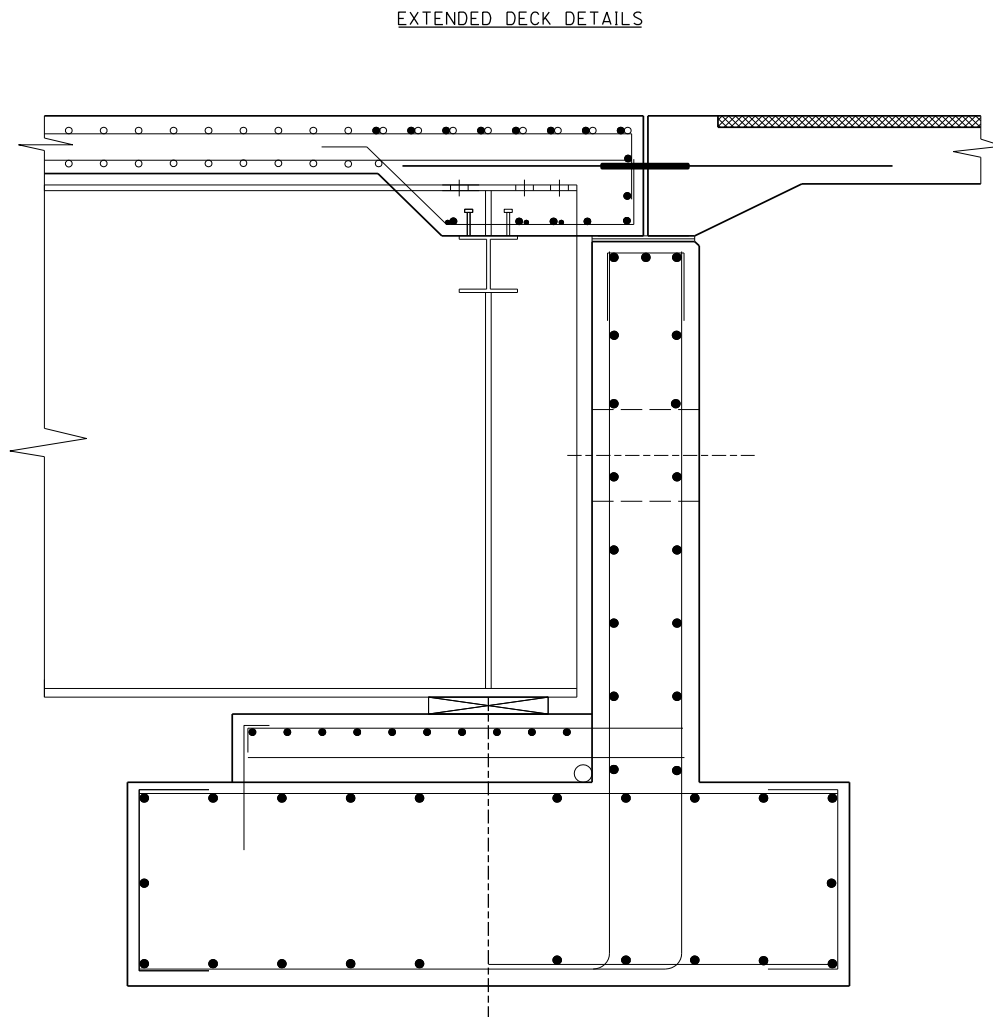

Figure 1.6.1.10A

SEMI-INTEGRAL BENT DETAILS

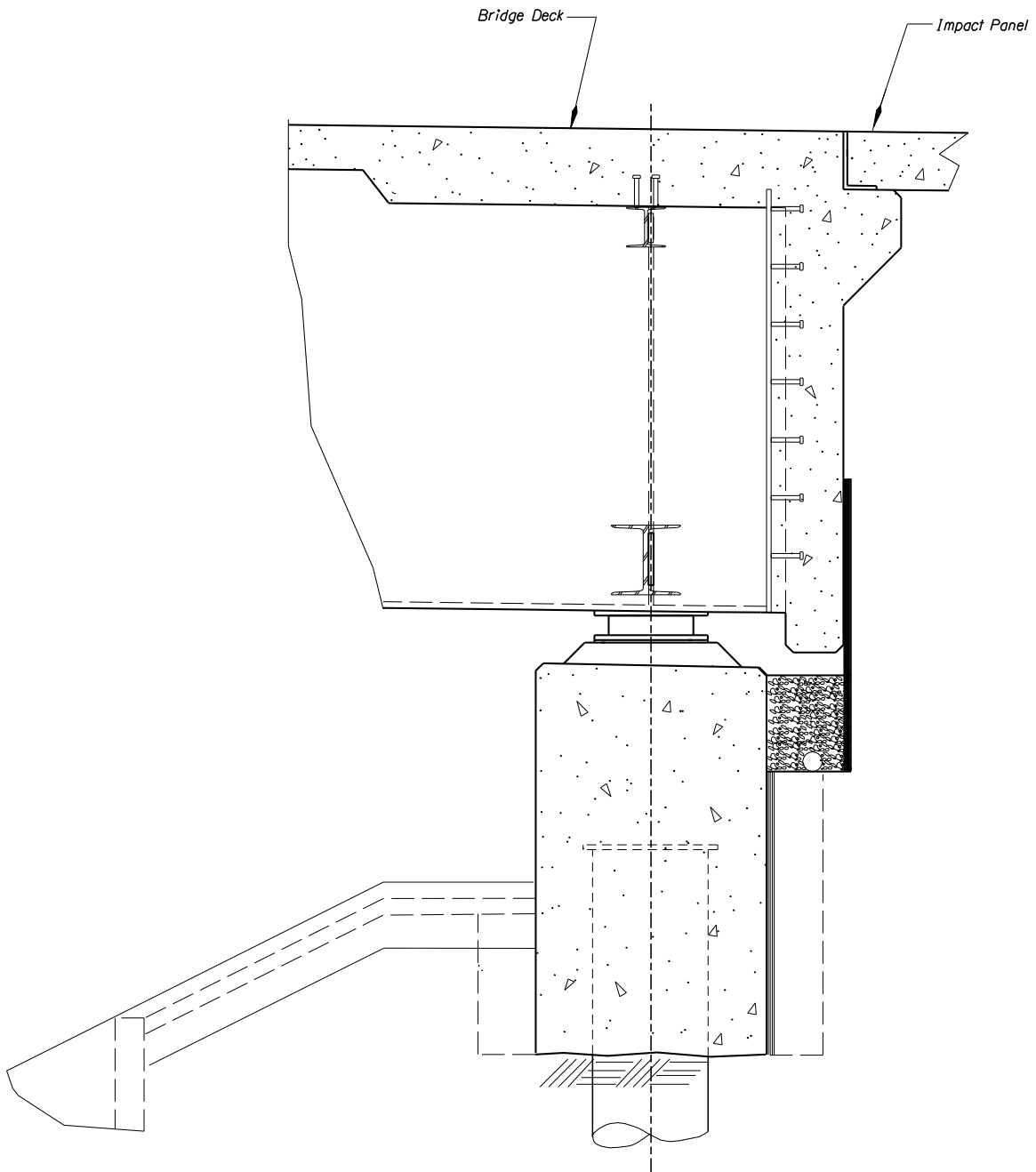

Figure 1.6.1.10B

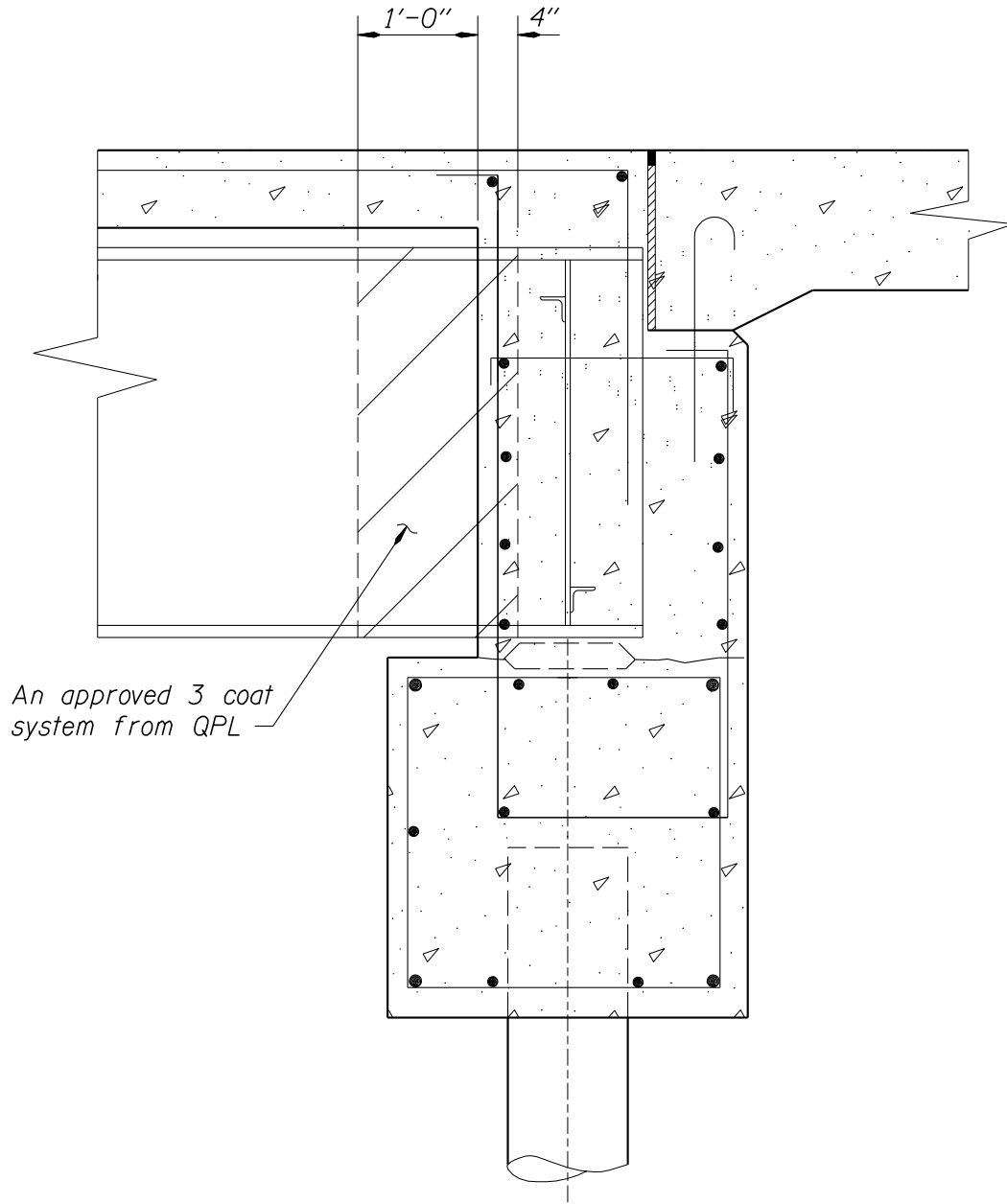

Figure 1.6.1.10C

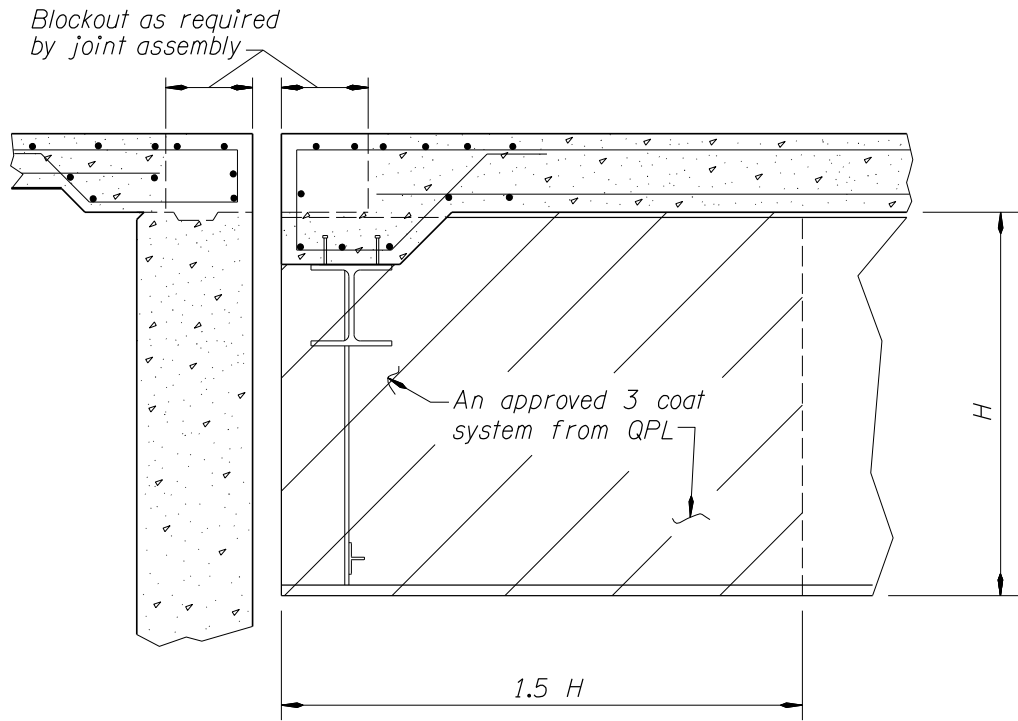

Figure 1.6.1.10D

1.6.1.11 Expansion Joint Blockouts

Show a blockout detail (see [Figures 1.14.2A](#)) on the plans to allow the expansion joint assembly to be placed a period of time after the final deck pour. Providing a blockout makes the adjacent deck pour easier, provides smoother deck transition to joint, and allows the majority of the superstructure shrinkage to occur prior to joint assembly placement.

1.6.1.12 Bearings

Due to high cost, try to avoid using built up steel bearings, pot bearings, and spherical bearings.

Design integral jointless bridges or use elastomeric bearings wherever possible.

Use circular elastomeric bearings on curved steel girders.

See also [BDM 1.14.1](#).

See [G9.1-2004, Steel Bridge Bearing Design and Detailing Guidelines](#) for additional guidance. See Drawing E2.3 for prefer bearing anchor rods connection detail.

1.6.1.13 Structure Widening

Generally, to avoid transferring dead loads from the widening to existing beams, diaphragms are temporarily connected to resist lateral loads only and a closure pour is made between the deck pours. An example is shown below.

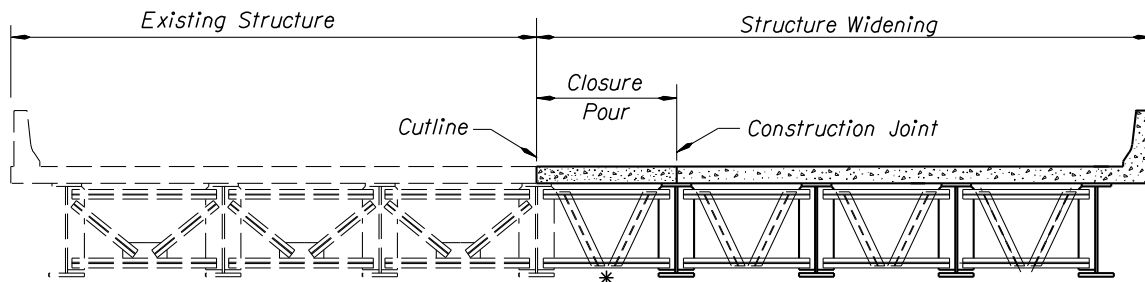

Note:
Place closure pour a minimum of 3 days
after adjacent deck widening concrete
placement.

Figure 1.6.1.13A

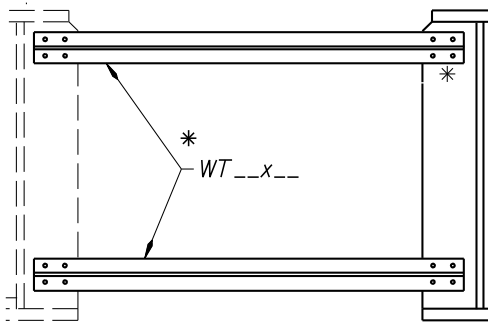

* *NOTE* : Install temporary 4- ___ dia. H. S. bolts (A325) (snug tight) in each end of each horizontal WT ___x___ and omit the diagonal WT ___x___'s until the entire deck and closure pours have been completed.

Figure 1.6.1.13B

1.6.2 Welding

1.6.2.1 Welding, General

Technical Assistance – The ODOT Welding Engineer may be consulted for assistance with welded connections.

General categories of welding - The following three categories loosely describe the most common types of welding needed for design work in roadway and bridge sections.

Incidental Structures (AWS D1.1): Welding under this category consists of light structural joining such as handrails, fencing, and sheet metal products. In general the weld is not required to fully develop the strength of the joining parts. Visual inspection of the final product is all that is expected.

General Structural Welding (AWS D1.1): Welding under this category consists of partially or fully developing the strength of the joining parts such as pile splices and attachments, guard rails, signing and lighting support, expansion joints (unless prefabricated by an approved supplier), seismic restraint fixtures and bearings (unless directly welding to main structural elements of a bridge). In general the weld will develop the ultimate strength of the joining parts but is not expected to provide maximum fatigue life *unless nondestructive testing is specified for acceptance*.

Structural Welding of Reinforcing Steel (AWS D1.4): Welding under this category consists of splicing and/or anchoring either new construction or existing reinforcing steel in concrete columns and girders. Note that *LRFD 9.7.2.5* does not allow welded splices of bridge deck reinforcement due to fatigue considerations. The particular weld joint design usually consists of either flare-bevel welds or butt joints with back up bars see *Figure 1.11.3.6B* for examples. In general it is desired to develop the full strength of the reinforcing steel to be joined. Almost any type of reinforcing steel can be successfully welded provided the chemistry of the steel is known (from either mill certifications or field testing) and an appropriate welding procedure is developed and followed. Unknown steels need to have a sample extracted (approximately 2 to 4 grams) and testing for chemistry. The welding procedure is developed from AWS D1.4 using the carbon equivalent method. This type of welding is almost always performed in the field and thus needs to be monitored by a certified welding inspector (CWI). Acceptance is usually based on visual examination but other methods can be used if the designer is concerned about fatigue. Make sure that the Contractor provides a CWI during field welding.

Bridge Welding (AWS D1.5): Welding under this category consists of fabricating or modifying any main load path carrying members of a bridge that have some or all portions that experience tensile stresses under normal loads. This includes girders, floor beams, stringers, trusses, and hanger assemblies. The member

does not necessarily have to be fracture critical. In general the welding is expected to develop both full ultimate strength of the joining parts and maximum fatigue performance. Joint toughness and nondestructive testing are typically required for acceptance.

Certification of Steel Fabricators: *SP 00560.30* requires the American Institute of Steel Construction (AISC) Category CBR (Major Steel Bridges) Certification for fabricators of structural steel bridges. If the structure is Fracture Critical, the fabricator also is required to have the AISC Fracture Critical endorsement.

Typical pathways for successful welding in your design:

Incidental welding:

- 1) Specify the welds needed on the drawings (type, size, and length).
- 2) In general welding procedure specifications and welder certification are not required to be submitted.
- 3) Quality assurance will be based on general appearance (visual testing) only. If you want a trained person to inspect the workmanship send a copy of the plans to the ODOT Portland Materials Inspection Crew. The same inspectors will also check for quality of painting and galvanizing. If the workmanship is poor then the parts can be rejected.

General Structural Welding:

- 1) Specify the welds needed on the drawings (type, size, and length). Even though the Standard Specifications invoke AWS D1.1 welding code for all incidentals structures, it is recommended that the following statement be included on the drawings (usually the plan and elevations):

“All welding shall conform to the AWS D1.1 Structural Welding Code.”

- 2) Generally welding procedure specifications (WPS) and welder certification are required to be submitted and approved. Any shop drawings that have welding shown are not legally approved until the WPS are approved under AWS D1.1.
- 3) Quality assurance is typically based on visual inspection by a certified welding inspector (CWI) and may also incorporate nondestructive testing such as ultrasonic (UT), radiographic (RT), and magnetic particle (MT) testing if specified on the design drawings. Various stages of the fabrication process may also be monitored if necessary. It is recommended that a copy of all plans and specifications that require this category of welding be sent to the ODOT Portland Materials Inspection Crew.

Reinforcing Steel Welding:

- 1) Specify the welds needed on the drawings (type, size, and length).
- 2) In the general notes for the job, put the following:

"All reinforcing steel welding shall conform to AWS D1.4 Structural Reinforcing Steel"
- 3) If the steel is not ASTM A615 or A706 a field chemistry sample needs to be extracted and analyzed for the carbon equivalent. The welding procedure shall be based on this information. If the steel is A615 or A706 the D1.4 welding code has recommended heat inputs.
- 4) Inform the ODOT Portland Materials Office of the work and have a CWI review the welding procedure, welder certification and observe the welding.

Bridge Welding:

1) Specify the welds needed on the drawings (type, size, and length). Calling out the specific weld ID number (i.e. TC-U4a is an example) is preferable but not required. *Typically this category of welding requires a significant Quality Assurance (QA) effort so please include this in your construction cost estimate.*

Even though the Standard Specifications invoke AWS D1.5 welding code for all bridge welding it is recommended that the following statement be included on the drawings (usually the plan and elevations):

“All welding shall conform to the AWS D1.5 Bridge Welding Code.”

2) Welding procedure specifications (WPS) and welder certification are required to be submitted and approved by the Engineer of Record. Any shop drawings that have welding shown are not legally approved until the WPS are approved under AWS D1.5.

3) Quality assurance is based on a more complicated Owner/Fabricator relationship that involves frequent inspections during the entire fabrication and erection process. Most individuals involved have stringent requirements for their duties including certified welders, inspectors, fabricators, and testing personnel. Most welding in this category requires some form of nondestructive testing for acceptance. Theoretically all materials and processes are traceable with archived documentation. Send a copy of all plans and specifications that require this category of welding to the ODOT Portland Materials Inspection Crew.

1.6.2.2 Fillet Welds

When adequate structural performance from fillet welds in "T" and corner joints can be obtained, use fillet weld in preference to groove welds. Fillet welds can be non-destructively inspected with greater certainty of result and at lower cost. The minimum fillet weld size for prequalified joints is shown below:

Material Thickness of Thicker Part Joined (T) (in)	Minimum Size* of Fillet Weld (in)
To 3/4 inclusive	1/4 **
Over 3/4	5/16 **

* Except that the weld size need not exceed the thickness of the thinner part joined. For this exception, take particular care to provide sufficient preheat to ensure weld soundness.

** Welds of this size must be made in a single pass.

Size fillet welds in accordance with AASHTO LRFD Design Specifications.

Web to flange connection

Use the minimum fillet weld necessary to join the flange to the web. This size will vary along the length of the girder depending on the size of the plates being joined.

Shear stress capacity of fillet welds (equal legs):

- LRFD Design - $F_v = 0.6 \times 0.8 F_{exx} \times 0.707 "t"$ (*LRFD 6.13.3.2.2b*)

where: F_{exx} = 58,000 psi for Grade 36 Steel
 F_{exx} = 65,000 psi for Grade 50 Steel
 $"t"$ = length fillet leg

Fillet Weld Capacity - LRFD Design (lb/in)		
Leg Length "t" (in)	Grade 36 Steel	Grade 50 Steel
3/16	3690	4135
1/4	4920	5510
5/16	6150	6890
3/8	7380	8270
7/16	8610	9650
1/2	9840	11,025
9/16	11,070	12,405
5/8	12,300	13,785

Figure 1.6.2.2A

1.6.2.3 Flange Welds

The design tensile stress in butt welded joints may equal the allowable stress in the base metal.

Show flange butt weld splices as in the detail below. Include this detail on all steel structure plans. Indicate the type of butt weld splice for each splice on the plans. This may be accomplished by:

- Adding the word "tension" or "compression", whichever is the case, to the tail of the weld symbol.
- Indicating which flanges or which portions of the flanges are in compression (C) and which are in tension (T).

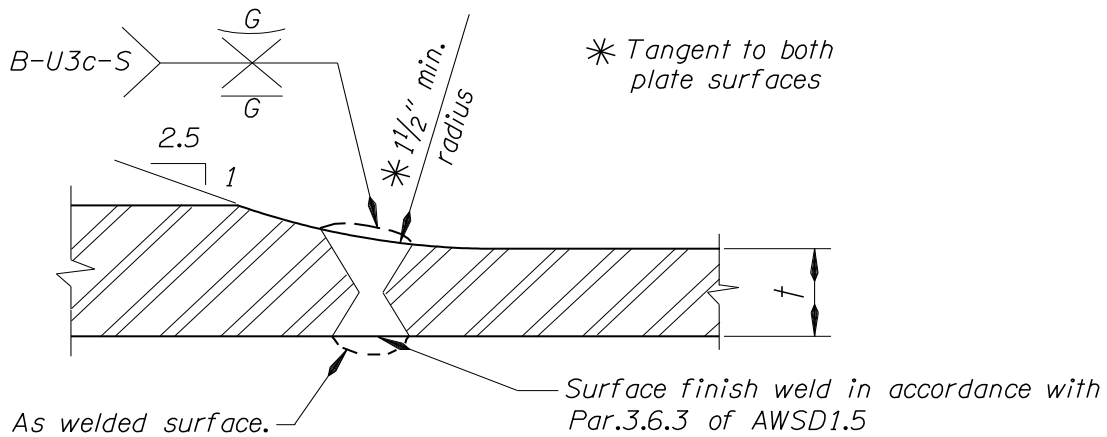

FLANGE SPLICE

Figure 1.6.2.3A

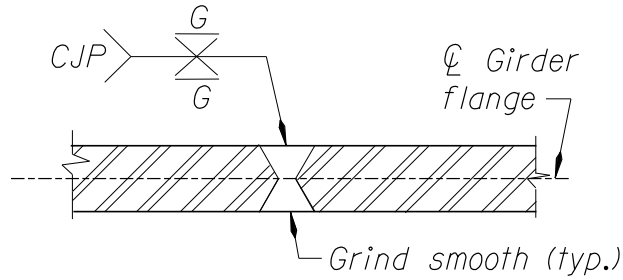

EQUAL THICKNESS FLANGE SPLICE

Figure 1.6.2.3B

1.6.2.4 Welded Web Splices in Steel Bridge Girders

Use complete joint penetration butt weld in web splices. Ground off 100 percent of the weldments reinforcing of all web splices. To facilitate NDE during fabrication, specify on the design drawings which portion of the girder webs are tension and compression. (see [Figures 1.6.2.4A](#) and [1.6.2.4B](#))

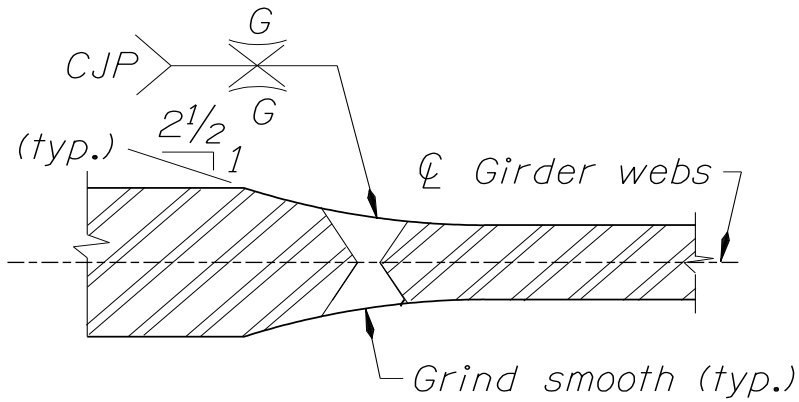

UNEQUAL THICKNESS WEB SPLICE

Figure 1.6.2.4A

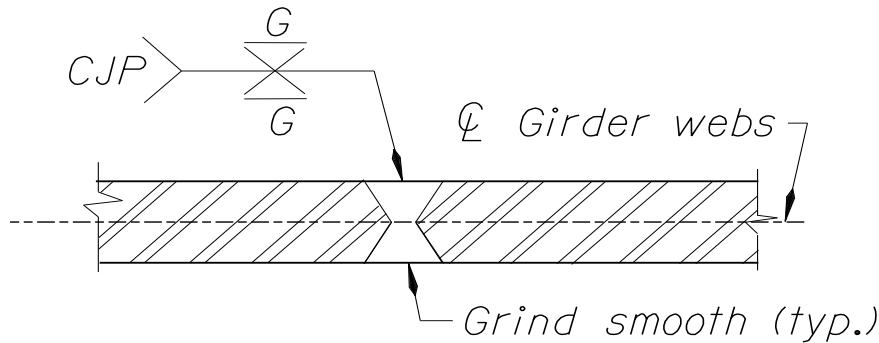

EQUAL THICKNESS WEB SPLICE

Figure 1.6.2.4B

1.6.3 Galvanizing and Painting

1.6.3.1 Processes

Galvanizing is a process of applying a sacrificial metal (zinc) to a base metal. The zinc will corrode, or sacrifice itself, to protect the base metal. Hot-dip galvanizing involves cleaning the items with a combination of caustic and acidic solutions and the dipping them into a tank of molten zinc for a specified period of time. After removal, small items are spun to remove excess zinc.

Mechanical galvanizing involves cleaning as mentioned above and then loading the items in a multi-sided rotating barrel. The barrel contains a mixture of various sized beads and water. As the barrel turns, chemicals and powdered zinc are added. The collision between the items, the glass beads and zinc causes the zinc to cold weld to the part. Powdered zinc is added until the required thickness is obtained.

Hot-dip galvanizing has proven to provide better long term corrosion protection and should be required for all galvanized items.

1.6.3.2 Detailing

To ensure proper hot-dip galvanizing, venting and drain holes must be provided in details. These insure proper circulation and removal of cleaning solutions and the molten zinc. They may also prevent potential explosions during dipping caused by trapped air.

Provide a minimum vent opening of 25 to 30 percent of the cross-sectional area of a tubular section if full open venting is not possible. Provide drains holes at closed corners or clip all corners at gusset plates to allow complete drainage.

1.6.3.3 Silicon Control

The silicon content of the steel influences the corrosion resistance and strength of the galvanized coating and the thickness of the zinc layer. The silicon content of the steel must be held within either of the range of 0 to 0.06 percent, or 0.153 to 0.25 percent to obtain and maintain a pleasing appearance. Call out all

members that will have visual impact on the drawings with "Galvanize - Control Silicon". Examples of these members are the chords, posts and diagonals of sign bridges; arms and shafts of luminaire, sign and signal support structures; steel traffic rail posts and railing members and pedestrian railings.

For economic reasons, silicon need not be controlled in galvanized structural members that are hidden from motorist view or are too small to have significant visual impact. Generally, these members that are too small to have significant visual impact are steel shapes whose least dimension does not exceed 3 inches.

An example of an exception is pedestrian rail members that should have silicon control. Examples of hidden members and others which for practical reasons do not require silicon control are base plates and guard rail connection plates, flex-beam rails and their posts and single-post, breakaway sign posts.

The general notes on each contract drawing that includes members are to be called out as "Galvanize-Control Silicon". The specification for control of silicon in steels to be galvanized is included in the Standard Specifications for Construction.

1.6.3.4 Painting or coating of new or existing metal

Coating of metal structures is discouraged in most circumstances due to maintenance costs of recoating. Weathering steel and galvanizing are preferred options. Sacrificial thickness is another option that may be appropriate in some circumstances. Perform a life cycle cost comparison when considering sacrificial thickness vs coated steel. Include the cost comparison in the TS&L narrative. Coating steel may be appropriate in the following situations:

- Marine environments (as defined in *BDM 1.26.1*)
- When use of weathering steel is improper per *BDM 1.6.1.1(2)*
- Structure is easily accessible and has minimally restricted lane closures (i.e. does not cross a roadway)

Coating work consists of preparing and coating new metal structures and features in the shop and in the field, and preparing and coating existing metal structures. This includes all:

- Interior and exterior steel surfaces
- Steel railings, bridge bearings, and bridge expansion joint assemblies
- Other miscellaneous steel

Coating of metal structures shall be in conformance with *SP 00594* and the special provisions. Powder coating is discussed in *SP 00593*.

1.6.3.4.1 Design Features of Coated Steel

Provide the following design features for bridges fabricated from coated structural steel:

1. Where structure access and lane closures are expected to be improbable, consider providing additional vertical clearance beyond the required minimum (per *BDM 3.14.4.2*) according to the following criteria. Allow for future ACWS overlay if applicable.
 - For box girders: Half of the box girder bottom flange width + 1 foot, but not exceeding 3 feet
 - For plate girders: Width of the girder bottom flange, but not exceeding 3 feet
 - All other situations: 1.5 feet

Additional vertical clearance only needs to be provided at girders over traffic lanes or where low water clearance is expected. This is to allow a minimal amount of access for work platforms and performing the work on the lowest members over traffic, without affecting freight movement.

Evaluate providing additional clearance with the project team based on the following criteria:

- Projected AADT – projected AADT high enough to impact future lane closures
- Railroad project involvement – railroad involvement will restrict structure access
- Freeway projects - either on or above
- Urban locations – surroundings (buildings, structures, utilities, etc.) may confine and limit access

Weigh the economic impact of increasing vertical clearances against future recoating maintenance.

- When evaluating increased project construction cost due to a raised profile, consider the following items that may be affected:
 - Roadway construction due to a grade profile change
 - Environmental impact and mitigation
 - Additional right-of-way needs
 - Retaining wall(s) needs
 - Seismic requirements (i.e. increased column heights, foundation stabilization)
 - Over-height warning system - for protecting workers on platforms over live traffic
- When only the minimum required clearance is provided (no additional), it will be more difficult and costly to recoat the bridge in the future. Reduced clearances typically require lane closures, detours, or night work to gain access to the work. In high traffic areas where lane closure are prohibited the efficiency of the work can be further degraded when allowable work shifts are too short. Evaluate the following items, with assistance from the Senior Cost Engineer and the Structure Coatings Engineer, when considering lifecycle costs of future painting when only the minimum required clearance (no additional) is provided:
 - Over-height warning system
 - Additional traffic control
 - Detours
 - Effect of night work
 - Mobilizing and demobilizing equipment each work shift; effect of work shifts that are not long enough for reasonable efficiency
 - Increase in access and containment cost due to complexity and additional setups
 - Increase in surface preparation cost due to reduced efficiency
 - Increase in coating application cost due to reduced efficiency
 - Increase in traffic control or detour costs due to reduced efficiency
 - Increased overhead costs due to reduced efficiency (longer calendar duration of work)
 - Delay costs borne by the public

Document the various clearance alternatives, including cost comparisons (based on the items outlined above) and justifications in the TS&L narrative. Submit a design deviation when providing additional clearance beyond the required minimum.

2. A minimum of 3 feet horizontal separation between the front face of traffic rail and the nearest steel surface (e.g. tied arch and stacked deck structures). This is to allow a minimal amount of access for scaffolding, worker and/or traffic protection shielding, and performing the work on the members closest to traffic, without affecting traffic or freight movement.
3. Stainless steel padeyes, stainless steel eyebolts or deck inserts located at appropriate intervals (approximately 15 by 15 foot to 20 by 20 foot grid typical) for support of future work platforms from upper structure members above roadway, main structure members below roadway, and the deck. This is to allow surface preparation and coating of members without having to move hangers, beam clamps, chains, cables or chokers. These temporary attachment points require extra work and often receive poor surface preparation and coating. List the allowable loading for the attachment points in the structural notes on the bridge plans. This requirement may be coordinated with the inspection requirements of *BDM 2.6.2*.

4. In the LRFD Strength and Service design include a Temporary Load representing the dead loads, live loads and wind loads acting on work platforms, scaffolding and containment needed to recoat the bridge. Add this Temporary Load to each applicable Load Combination as shown in *LRFD Table 3.4.1*, using a load factor of:
- 1.50 for Strength and Extreme Event limit states
 - 1.00 for Service I and Fatigue limit states
 - 1.25 for Service II limit state.

Design work platforms that access the structure with little need for scaffolding for a DL + LL of 25 pounds per square foot of platform area. Design work platforms that require significant scaffolding to reach the structure for a DL + LL of at least 50 pounds per square foot. Assume work platforms and containment extent to 5 feet beyond the sides of the structure and full length to 5 feet beyond the ends of the entire structure or each span. List the permissible work platform sizes and loading, and the permissible containment sizes and wind speeds in the structural notes on the bridge plans. It may be necessary to separate the work platforms and/or containment into zones for structural reasons, in which case carefully size the zones to allow efficient work by the recoating contractor.

5. Do not create spaces where blind sides of members cannot be reached for surface preparation and coating work.
6. Closed members or areas which are too small for workers to enter to perform surface preparation and coating work are highly discouraged. When the member is too small for a worker to turn around in, but larger than 2 by 3 feet, provide access openings 18 by 30 inches minimum with semicircular ends, spaced from 42 to 60 inches on centers. For members up to 2 by 3 feet, provide hand hole access 6 by 12 inches with semicircular ends, spaced 30 inches on center. For members large enough for workers to enter see *BDM 2.6* for additional accessibility guidance.

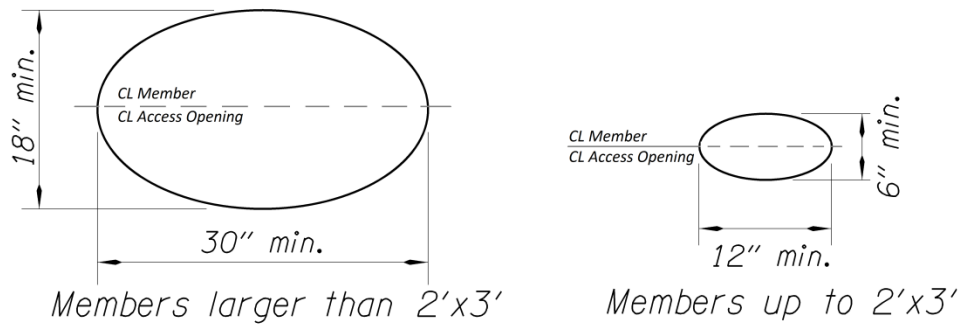

Figure 1.6.3.4

1.6.3.5 Process for recoating of an existing metal structure

Be aware of an existing structure's condition prior to completing TS&L of a recoating project. Recoating of an existing bridge is very costly and requires a careful examination of the structure's condition. Older structures are typically painted and have potential deficiencies that may need to be addressed during a recoating project. Collect all necessary information for such projects. The [Steel Bridge Recoating Checklist](#) in *BDM A1.6.3.5* provides a list of required information and guidance on specifications. Complete the checklist and include in the TS&L Report.

Include additional costs for access, paint removal and recoating rivet or bolt replacements, if rivets or bolts are outside normal paint area limits.

1.6.4 Bolts and Connections

Design all high-strength bolted connections as slip-critical connections. Assume Class B faying surfaces where inorganic zinc primer is used. If steel will be given a full paint system in the shop, the primed faying surfaces need to be masked to maintain the Class B surface.

1.6.4.1 High Strength Bolts

High-Strength Bolt Use Guidelines:

- ASTM F3125 GR A325 & GR F1852 - Headed structural bolt for use in structural connections. These may be hot-dip galvanized. Do not specify for anchor bolts.
- Use Type 3 bolts conforming to ASTM F3125 when specifying weathering steel.
- ASTM A449 - Steel bolts and studs for general applications including anchor bolts. Recommended for use where strengths equivalent to ASTM F 3125 GR A325 bolts are desired but custom geometry or lengths are required. Strengths for ASTM A449 bolts are equivalent to GR A325 up to 1" diameter. If using bolts of larger diameter, a reduction in strength as indicated in the table below shall be accounted for. These bolts may be hot-dip galvanized. Do not use these as anchor bolts for seismic applications due to low CVN impact toughness.
- ASTM F3125 GR A490 & GR F2280 - Alloy steel headed structural bolt for use in structural connections. Do not use ASTM F3125 GR A490 bolts in bridge applications. If there is a compelling reason to use ASTM F3125 GR A490 bolts, request a BDM Deviation. When a deviation is approved, do not galvanize these bolts because of high susceptibility to hydrogen embrittlement. Instead of galvanizing, require two or three coats of approved zinc rich paint. Do not specify for anchor bolts.
- F1554 Grade 105 - Higher strength anchor bolts to be used for larger sizes (1½" to 4"). When used in seismic applications, such as bridge bearings that resist lateral loads, specify supplemental CVN requirement S4 with a test temperature of -20°F. Lower grades may also be suitable for sign structure foundations. This specification should also be considered for seismic restrainer rods, and may be galvanized.

1.6.4.2 Properties of High-Strength Bolts

Material	Bolt Diameter (in)	Tensile Strength (ksi)	Yield Strength (ksi)
ASTM F3125 GR A325 & GR F1852	½ – 1½	120	92
	Over 1½		Not Available
ASTM A449	¼ – 1	120	92
	1⅞ – 1½	105	81
	1¾ – 3	90	58
	Over 3		Not Available
ASTM F1554 GR 105	¼ – 3	125 – 150	105
ASTM F1554 GR 55	¼ – 4	75 – 95	55
ASTM F1554 GR 36	¼ – 4	58 – 80	36
ASTM F3125 GR A490 & GR F2280	½ – 1½	150 – 173 (max)	130
	Over 1½		Not Available

1.7 ALUMINUM

[1.7.1 Aluminum](#)

[1.7.1 Aluminum](#)

(Reserved for future use)

1.8 TIMBER BRIDGE DESIGN AND DETAILING

[1.8.1 Timber Bridge Locations](#)

[1.8.2 Timber Design and Details](#)

[1.8.3 Timber Connections](#)

[1.8.4 Timber Rails](#)

[1.8.5 Preservative Treatments](#)

[1.8.6 Field Installation](#)

1.8.1 Timber Bridge Locations

Timber structures may be considered as an alternate to concrete structures on low volume highways or roads with an AADT of less than 500, especially for sites located away from possible concrete sources. Timber bridges are generally best suited to the drier climate east of the Cascade Mountains. Consult the individual Regions in the early stages of a project to determine whether a timber bridge is desired.

1.8.2 Timber Design and Details

Before specifying structural grades for timber members, check with the fabrication industry for actual availability.

Unless timber is submerged, it may be considered dry for design.

ODOT does not design composite wood-concrete structures and has no corresponding construction specifications.

For structures carrying only pedestrian and/or bicycle traffic, the maximum allowable live load deflection is:

- For simple or continuous spans span/360
- For cantilever arms arm length/135

Glued laminated timber bridges

Glued laminated timber bridge single spans are generally feasible up to 50 feet. To achieve longer spans, consider cantilever techniques. The width of glued laminated beams is generally limited to 10-3/4" or less, but 12-3/4", 14-3/4", and 16-3/4" widths are available for extra cost.

Give consideration to performance specification for glued laminated timber members. Identifying actual stresses for bending, horizontal shear, etc., is preferred by the fabrication industry instead of specifying an actual glued laminated timber grades.

The preference of the Bridge Section at this time is the use of a non-interconnected glued laminated timber deck as opposed to an interconnected glued laminated timber deck. A longitudinal timber stiffener under the deck between longitudinal beams for transverse deck bridges may be beneficial for differential deflection control.

A glued laminated longitudinal deck bridge is a possible solution for short spans (under 25 feet) with a tight freeboard clearance requirement. These deck members could be used in a continuous span arrangement to increase member efficiency.

Include a waterproofing membrane according to *BDM 1.26.4* when using an asphalt wearing surface.

For smaller timber members, such as posts, rails, etc., specifying solid sawn timber as an option to glued laminated timber may be more cost effective.

Timber substructures are not recommended.

1.8.3 Timber Connections

Use of the "Weyerhaeuser clip" to connect timber decking to timber beams allow for easy fabrication and installation of the timber members.

Steel diaphragm beams, as opposed to timber diaphragm beams, between longitudinal glued laminated timber beams are recommended.

Use slotted holes whenever possible in the steel connectors to allow for shrinkage and expansion of the wood, and for construction tolerances.

1.8.4 Timber Rails

A crash-tested rail has been completed for a longitudinal glued laminated timber deck bridge. Several other glued laminated timber bridge configurations will be crash-tested in the near future. Thrie beam railing can be used as an alternate in lieu of timber.

1.8.5 Preservative Treatments

Pentachlorophenol Type A (heavy solvent) or Pentachlorophenol Type C (light solvent) is recommended for most locations as a preservative treatment.

Eliminate all field cuts and bores if possible. Treat any field modifications with copper naphthanate.

1.8.6 Field Installation

Shop assembly of the timber bridge components immediately after fabrication is recommended to eliminate any possible future field installation problems, especially on more complicated projects.

Field staking of the structure before fabrication is recommended to eliminate any future installation problems.

1.9 DECKS

[1.9.1 Design and Detailing](#)

[1.9.2 Deck Screeding](#)

[1.9.3 Deck Construction Joints](#)

[1.9.4 Deck Overlays](#)

[1.9.1 Design and Detailing](#)

Design

Design decks according to AASHTO *LRFD Bridge Design Specifications*.

Do not use the empirical design method for deck reinforcing steel. Excessive deck cracking, apparently due to under reinforcement, precludes the use of this method until further notice.

Do not consider bridge railings to be structurally continuous for the purposes of distributing the deck loads per LRFD 3.6.1.3.4 as this limits options for bridge rail retrofits in the future.

For additional deck requirements on Precast Prestressed elements, see *BDM 1.5.6.1*.

For deck protective practice requirements, such as cover and reinforcement type, see *BDM 1.26.3*.

For cast-in-place decks, discount ½ inch deck thickness when calculating composite properties for girder/slab systems. For a typical 8 inch deck, 7½ inch would be considered structural and 1/2 inch would be considered a sacrificial wearing surface and included as non-composite dead load.

The preferred orientation of the top mat of deck steel will have the transverse bars on top when the direction of primary loading is transverse.

For skewed decks, orient transverse bars according to *LRFD 9.7.1.3*. Per *LRFD 9.7.1.3*, the primary reinforcement may be orientated along the skew for skew angles that do not exceed 25 degrees, where the skew angle is measured from a line that is perpendicular to the centerline of the bridge to the centerline of the support. However, there is no guidance when skew angle exceeds 25 degrees.

The acute corners of a skewed (> 25 degrees) concrete deck slab are often difficult to adequately reinforce. As the angle of skew increases, large portions of the deck can be unreinforced and therefore subject to spalling and chipping, as shown in *Figure 1.9.1*. Because the orthogonal bars are too short to develop, it is typically necessary to detail diagonal bars that extend into the deck over the girders, to carry the deck overhang loads. Similarly, acute corners in concrete barriers are also difficult to reinforce, and require special consideration.

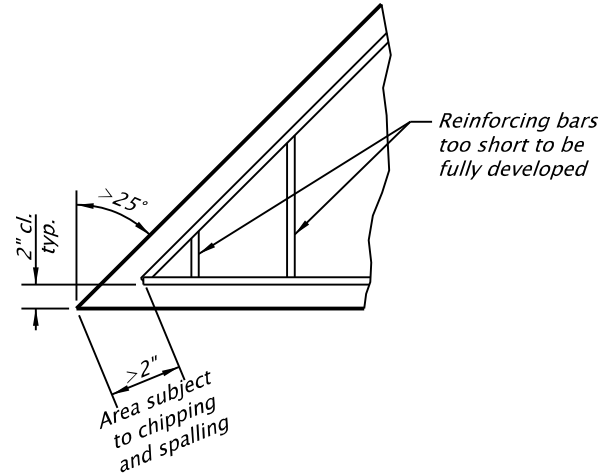

Figure 1.9.1.1 Inadequate reinforcement provided in acute corner of concrete deck slab

Use breakback detailing where the ends of the skewed deck are turned so that the end is normal to the longitudinal edge of the deck, as shown in *Figure 1.9.2*. This breakback detailing effectively eliminates the acute and obtuse corners of the concrete deck and barriers. Use a minimum breakback width of 3'-0" and increase width with increased skew angle.

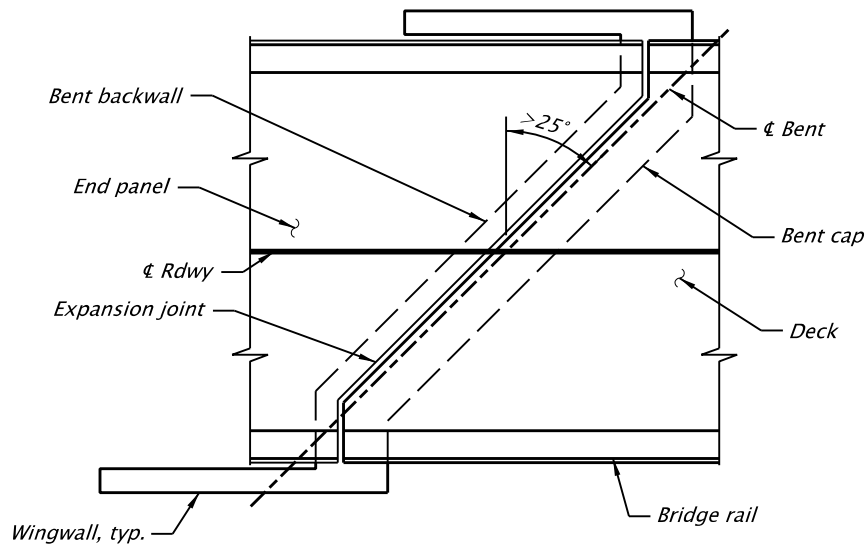

Figure 1.9.1.2 Breakback detailing to eliminate skew effects associated with detailing acute corners at ends of skewed deck slab

On skewed bridges with concrete end diaphragms and when a breakback detail is not used, place additional reinforcement in a radial manner to eliminate diagonal cracks which form in the acute corners of concrete deck. See *Figure 1.9.1.3* for the reinforcement pattern. The objective of the reinforcement fan is to offset buildup of shrinkage across the long diagonal dimension of the slab which would pull a shrinkage crack across the weak corner of the slab. A portion of the bars must extend back into the corner sufficiently to terminate above the junction of exterior beam and end diaphragm. Place a note on the plans that states "Place the corner reinforcement beneath the longitudinal and transverse reinforcement in the top of the slab."

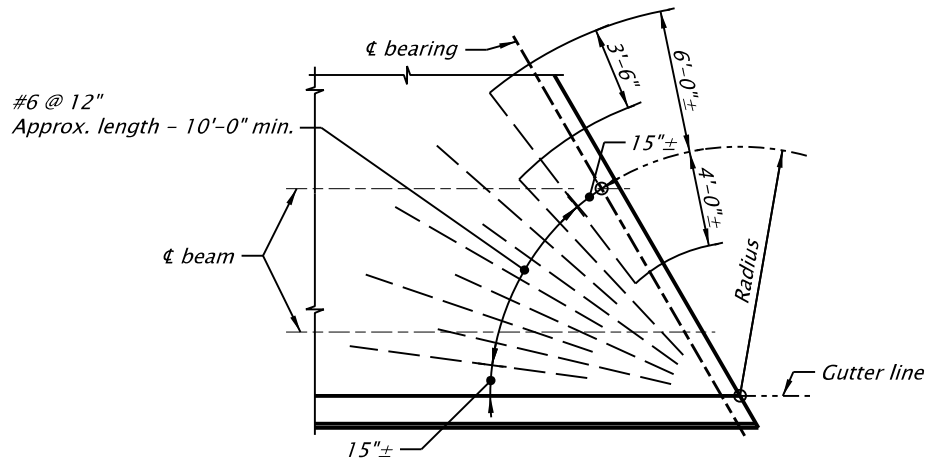

Figure 1.9.1.3 Corner Reinforcing Detailing

In skewed box girders, orient bottom slab transverse bars the same as the deck transverse bars. See *BDM 1.5.7.8* for additional bottom slab requirements. Note the intended bar placement on the bridge contract plans.

Do not use deck reinforcement larger than a #6 bar in typical deck steel, except when needed to resist negative moment for continuous-span girders. If necessary, larger bars may be used in distinct sections such as joints and post tensioned anchorage areas. When the top mat has longitudinal bars on top, any longitudinal reinforcement larger than a #6 bar will need to be placed in the bottom mat.

Unless a project specific deck reinforcement design is developed, for design and detailing use the “Concrete Deck Reinforcement (LRFD Design)”, *Figure 1.9.1A* or *1.9.1B* for Grade 60 reinforcement and Concrete Class HPC 4500, or *Figure 1.9.1C* or *1.9.1D* for Grade 80 reinforcement and Concrete Class HPC 4500.

Use of Grade 80 rebar is expected to reduce construction cost and potentially reduce rebar congestion. Verify the quantity of deck steel to determine if Grade 80 rebar is appropriate:

- When the quantity of deck steel using Grade 80 rebar exceeds 30 tons, provide details only for Grade 80 rebar.
- When the quantity of deck steel using Grade 80 rebar is less than 30 tons, provide details for both Grade 80 and Grade 60 rebar. Use Grade 80 for the primary details with Grade 60 shown as an alternate.

Ensure project specific deck design conforms to the following minimum requirements:

- *LRFD Section 4.6.2.1*
- Concrete Class: HPC4500 – 1-1/2 (except box girder decks that require greater strength)
- Reinforcement: Grade 60 or Grade 80
- Reinforcement no larger than #6 bar (except in distinct areas)
- Reinforcement spacing ≥ 5 inches and ≤ 8 inches (applies to top mat only)
- Surface wear allowance = 1/2 inch
- Limit top of concrete compressive service stress due to positive moment in the deck (between girders) to 0.4f'c.

Note that *LRFD 5.7.3.4* (Control of Cracking by Distribution of Reinforcement) is applicable for negative moment steel for bridges made continuous for live load, but is not applicable to bridge deck slab reinforcement. The 8 inch maximum bar spacing is adequate to control cracking in bridge decks.

Submit a design deviation request to the State Bridge Engineer for any concrete bridge deck designs not meeting any one of the minimum requirements listed above in *Figures 1.9.1A 1.9.1B, 1.9.1C* or *1.9.1D*.

Bridge Design Manual – June 2020
Oregon Department of Transportation
Section 1 – Design Standards

With the request, include the following:

- Design loading assumptions (dead, live, and future wearing surface)
- Documentation of which minimum requirements were met and which were not met
- Orientation of the top mat (longitudinal on top or transverse on top)
- Deck thickness
- Maximum service stress in the top of the deck due to positive moment in the deck (between girders)
- Maximum service stress in the bottom of the deck due to negative moment in the deck (over a girder)

Use cast-in-place HPC concrete or full depth precast deck panels with high-strength abrasion-resistant concrete in accordance with *BDM 1.9.1.1* for bridge decks. Partial depth precast deck panels will not be permitted.

CONCRETE DECK REINFORCEMENT (LRFD DESIGN) with TRANSVERSE BARS ON TOP
Steel Girders & Cast-In-Place Concrete Box Girders - Simple Spans

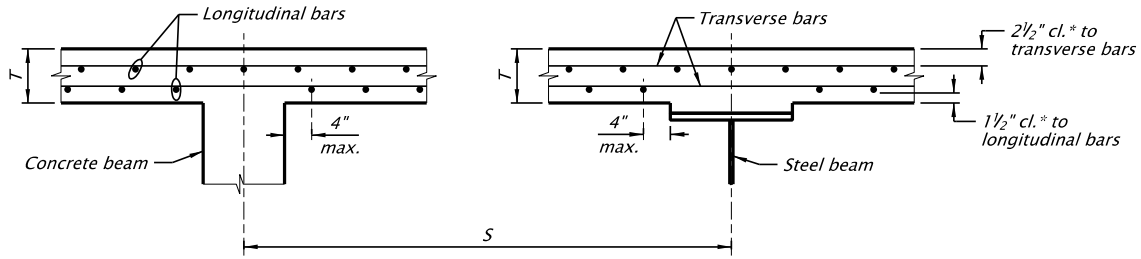

Assumptions:
Specifications: *LRFD 4.6.2.1*

Concrete Class: *HPC 4500*

Reinforcement: *Grade 60*

Top Mat Orientation: Transverse bars on top

Dead Load: 150 pcf + 50 psf future wearing surface

Deck DL moments: Negative $-0.10wS^2$
Positive $+0.08wS^2$

Live Load: *LRFD Table A4-1* using 6" from Φ of girder to the negative moment design section

Design Moment: $1.25*DL + 1.5*DW + 1.75*LL$
(Impact included in *LRFD Table A4-1* live loads)

Surface Wear: 1/2" allowance for surface wear subtracted from positive moment "d".

Steel Girders: Top flange width not less than 24". Project specific design is required when top flange is less than 24".

Concrete Box Girders: Girder stem width not less than 12"
For girder stem greater than or equal to 16", use Deck Design Chart for Precast P/S Concrete Members.

Note:
Additional reinforcement to accommodate rail loads at deck overhangs is not included in these details. The designer is responsible for design of overhangs.

Note:
"S" is measured parallel to the transverse bars. Bar spacing is measured perpendicular to the bars.

Place bottom mat bars directly below and in line with a top mat bar. At expansion and construction joints, however, it is not necessary for all bottom mat bars to be directly below a top mat bar.

* For coastal locations, specify 2" clear top and bottom.
See also *BDM 1.26.3* for additional corrosion protection recommendations.

Steel Girders & CIP Concrete Box Girders

Girder Spacing	Deck Thickness	Transverse Bars	Longitudinal Bars
5'-0"	8"	#4 @ 6 1/2"	#4 @ 8"
5'-3"	8"	#4 @ 6 1/2"	#4 @ 8"
5'-6"	8"	#4 @ 6 1/2"	#4 @ 8"
5'-9"	8"	#4 @ 6 1/2"	#4 @ 8"
6'-0"	8"	#4 @ 6"	#4 @ 8"
6'-3"	8"	#4 @ 6"	#4 @ 8"
6'-6"	8"	#4 @ 6"	#4 @ 8"
6'-9"	8"	#4 @ 6"	#4 @ 8"
7'-0"	8"	#4 @ 5 1/2"	#4 @ 8"
7'-3"	8"	#4 @ 5 1/2"	#4 @ 8"
7'-6"	8"	#4 @ 5 1/2"	#4 @ 8"
7'-9"	8"	#4 @ 5 1/2"	#4 @ 8"
8'-0"	8"	#4 @ 5"	#4 @ 7"
8'-3"	8"	#4 @ 5"	#4 @ 7"
8'-6"	8"	#4 @ 5"	#4 @ 7"
8'-9"	8"	#5 @ 6 1/2"	#5 @ 8"
9'-0"	8 1/4"	#5 @ 6 1/2"	#5 @ 8"
9'-3"	8 1/2"	#5 @ 6 1/2"	#5 @ 8"
9'-6"	8 1/2"	#5 @ 6 1/2"	#5 @ 8"
9'-9"	8 1/2"	#5 @ 6 1/2"	#5 @ 8"
10'-0"	8 3/4"	#5 @ 6 1/2"	#5 @ 8"
10'-3"	8 3/4"	#5 @ 6"	#5 @ 8"
10'-6"	8 3/4"	#5 @ 6"	#5 @ 8"
10'-9"	9"	#5 @ 6"	#5 @ 8"
11'-0"	9"	#5 @ 6"	#5 @ 8"
11'-3"	9"	#5 @ 5 1/2"	#5 @ 8"
11'-6"	9 1/4"	#5 @ 5 1/2"	#5 @ 8"
11'-9"	9 1/4"	#5 @ 5 1/2"	#5 @ 8"
12'-0"	9 1/2"	#5 @ 5 1/2"	#5 @ 8"
12'-3"	9 1/2"	#5 @ 5 1/2"	#5 @ 8"
12'-6"	9 3/4"	#5 @ 5 1/2"	#5 @ 8"
12'-9"	9 3/4"	#5 @ 5"	#5 @ 7"
13'-0"	10"	#5 @ 5"	#5 @ 7"
13'-3"	10"	#5 @ 5"	#5 @ 7"
13'-6"	10 1/4"	#5 @ 5"	#5 @ 7"
13'-9"	10 1/4"	#5 @ 5"	#5 @ 7"
14'-0"	10 1/2"	#5 @ 5"	#5 @ 7"
14'-3"	10 1/2"	#5 @ 5"	#5 @ 7"
14'-6"	10 3/4"	#5 @ 5"	#5 @ 7"
14'-9"	10 3/4"	#5 @ 5"	#5 @ 7"
15'-0"	11"	#5 @ 5"	#5 @ 7"

Figure 1.9.1A

CONCRETE DECK REINFORCEMENT (LRFD DESIGN) with TRANSVERSE BARS ON TOP
Standard Precast Prestressed Concrete members - Simple Spans

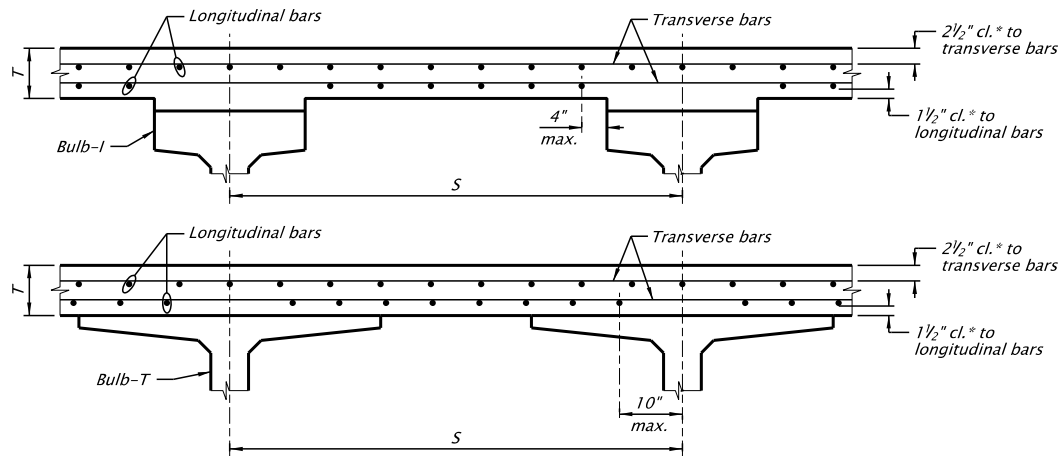

Assumptions:
 Specifications: *LRFD 4.6.2.1*

Concrete Class: *HPC 4500*

Reinforcement: *Grade 60*

Top Mat Orientation: Transverse bars on top

Dead Load: 150 pcf + 50 psf future wearing surface

Deck DL moments: Negative $-0.10wS^2$
 Positive $+0.08wS^2$

Live Load: *LRFD Table A4-1* using 8" from ϕ of girder to the negative moment design section

Design Moment: $1.25*DL + 1.5*DW + 1.75*LL$
 (Impact included in *LRFD Table A4-1* live loads)

Surface Wear: 1/2" allowance for surface wear subtracted from positive moment "d".

Note:
 Additional reinforcement to accommodate rail loads at deck overhangs is not included in these details. The designer is responsible for design of overhangs.

Note:
 "S" is measured parallel to the transverse bars. Bar spacing is measured perpendicular to the bars.

Place bottom mat bars directly below and in line with a top mat bar. At expansion and construction joints, however, it is not necessary for all bottom mat bars to be directly below a top mat bar.

* For coastal locations, specify 2" clear top and bottom. See also *BDM 1.26.3* for additional corrosion protection recommendations.

Precast Prestressed Concrete Members

Girder Spacing	Deck Thickness	Transverse Bars	Longitudinal Bars
5'-0"	8"	#4 @ 6 1/2"	#4 @ 8"
5'-3"	8"	#4 @ 6 1/2"	#4 @ 8"
5'-6"	8"	#4 @ 6 1/2"	#4 @ 8"
5'-9"	8"	#4 @ 6 1/2"	#4 @ 8"
6'-0"	8"	#4 @ 6 1/2"	#4 @ 8"
6'-3"	8"	#4 @ 6"	#4 @ 8"
6'-6"	8"	#4 @ 6"	#4 @ 8"
6'-9"	8"	#4 @ 6"	#4 @ 8"
7'-0"	8"	#4 @ 5 1/2"	#4 @ 8"
7'-3"	8"	#4 @ 5 1/2"	#4 @ 8"
7'-6"	8"	#4 @ 5 1/2"	#4 @ 8"
7'-9"	8"	#4 @ 5 1/2"	#4 @ 8"
8'-0"	8"	#5 @ 7 1/2"	#5 @ 8"
8'-3"	8"	#5 @ 7 1/2"	#5 @ 8"
8'-6"	8"	#5 @ 7 1/2"	#5 @ 8"
8'-9"	8"	#5 @ 7"	#5 @ 8"
9'-0"	8 1/4"	#5 @ 7"	#5 @ 8"
9'-3"	8 1/4"	#5 @ 7"	#5 @ 8"
9'-6"	8 1/2"	#5 @ 7"	#5 @ 8"
9'-9"	8 1/2"	#5 @ 7"	#5 @ 8"
10'-0"	8 1/2"	#5 @ 7"	#5 @ 8"
10'-3"	8 1/2"	#5 @ 6 1/2"	#5 @ 8"
10'-6"	8 3/4"	#5 @ 6 1/2"	#5 @ 8"
10'-9"	8 3/4"	#5 @ 6 1/2"	#5 @ 8"
11'-0"	9"	#5 @ 6 1/2"	#5 @ 8"
11'-3"	9"	#5 @ 6"	#5 @ 8"
11'-6"	9 1/4"	#5 @ 6"	#5 @ 8"
11'-9"	9 1/4"	#5 @ 6"	#5 @ 8"
12'-0"	9 1/2"	#5 @ 6"	#5 @ 8"

Figure 1.9.1B

CONCRETE DECK REINFORCEMENT (LRFD DESIGN) with TRANSVERSE BARS ON TOP
Steel Girders & Cast-In-Place Concrete Box Girders - Simple Spans

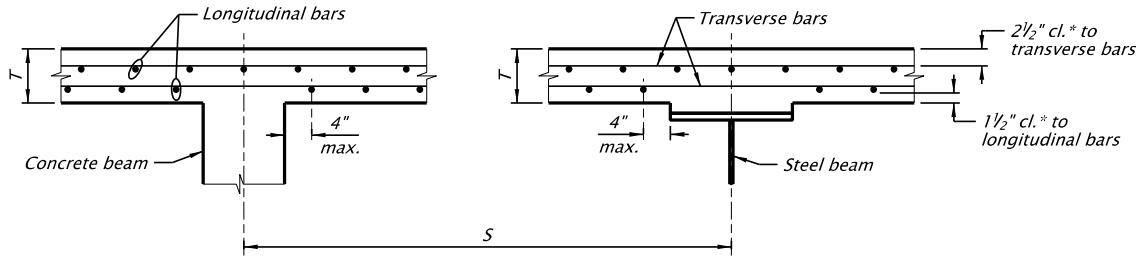

Assumptions:
 Specifications: *LRFD 4.6.2.1*

Concrete Class: *HPC 4500*

Reinforcement: *Grade 80*

Top Mat Orientation: Transverse bars on top

Dead Load: 150 pcf + 50 psf future wearing surface

Deck DL moments: Negative $-0.10wS^2$
 Positive $+0.08wS^2$

Live Load: *LRFD Table A4-1* using 6" from C of girder to the negative moment design section

Design Moment: $1.25*DL + 1.5*DW + 1.75*LL$
 (Impact included in *LRFD Table A4-1* live loads)

Surface Wear: 1/2" allowance for surface wear subtracted from positive moment "d".

Steel Girders: Top flange width not less than 24". Project specific design is required when top flange is less than 24".

Concrete Box Girders: Girder stem width not less than 12"
 For girder stem greater than or equal to 16", use Deck Design Chart for Precast P/S Concrete Members.

Note:
 Additional reinforcement to accommodate rail loads at deck overhangs is not included in these details. The designer is responsible for design of overhangs.

Note:
 "S" is measured parallel to the transverse bars. Bar spacing is measured perpendicular to the bars.

Place bottom mat bars directly below and in line with a top mat bar. At expansion and construction joints, however, it is not necessary for all bottom mat bars to be directly below a top mat bar.

* For coastal locations, specify 2" clear top and bottom.
 See also *BDM 1.26.3* for additional corrosion protection recommendations.

Steel Girders & CIP Concrete Box Girders

Girder Spacing	Deck Thickness	Transverse Bars	Longitudinal Bars
5'-0"	8"	#4 @ 8"	#4 @ 8"
5'-3"	8"	#4 @ 8"	#4 @ 8"
5'-6"	8"	#4 @ 7 1/2"	#4 @ 8"
5'-9"	8"	#4 @ 7 1/2"	#4 @ 8"
6'-0"	8"	#4 @ 7"	#4 @ 8"
6'-3"	8"	#4 @ 7"	#4 @ 8"
6'-6"	8"	#4 @ 6 1/2"	#4 @ 8"
6'-9"	8"	#4 @ 6 1/2"	#4 @ 8"
7'-0"	8"	#4 @ 6"	#4 @ 8"
7'-3"	8"	#4 @ 6"	#4 @ 8"
7'-6"	8"	#4 @ 6"	#4 @ 8"
7'-9"	8"	#4 @ 5 1/2"	#4 @ 8"
8'-0"	8"	#4 @ 5 1/2"	#4 @ 8"
8'-3"	8"	#4 @ 5 1/2"	#4 @ 8"
8'-6"	8"	#4 @ 5 1/2"	#4 @ 8"
8'-9"	8"	#4 @ 5 1/2"	#4 @ 8"
9'-0"	8 1/4"	#4 @ 5 1/2"	#4 @ 8"
9'-3"	8 1/4"	#4 @ 5 1/2"	#4 @ 8"
9'-6"	8 1/2"	#4 @ 5 1/2"	#4 @ 8"
9'-9"	8 1/2"	#4 @ 5"	#4 @ 7"
10'-0"	8 3/4"	#4 @ 5"	#4 @ 7"
10'-3"	8 3/4"	#4 @ 5"	#4 @ 7"
10'-6"	8 3/4"	#4 @ 5"	#4 @ 7"
10'-9"	9"	#4 @ 5"	#4 @ 7"
11'-0"	9"	#5 @ 6"	#5 @ 8"
11'-3"	9"	#5 @ 6"	#5 @ 8"
11'-6"	9 1/4"	#5 @ 6"	#5 @ 8"
11'-9"	9 1/4"	#5 @ 6"	#5 @ 8"
12'-0"	9 1/2"	#5 @ 6"	#5 @ 8"
12'-3"	9 1/2"	#5 @ 6"	#5 @ 8"
12'-6"	9 3/4"	#5 @ 6"	#5 @ 8"
12'-9"	9 3/4"	#5 @ 5 1/2"	#5 @ 8"
13'-0"	10"	#5 @ 5 1/2"	#5 @ 8"
13'-3"	10"	#5 @ 5 1/2"	#5 @ 8"
13'-6"	10 1/4"	#5 @ 5 1/2"	#5 @ 8"
13'-9"	10 1/4"	#5 @ 5 1/2"	#5 @ 8"
14'-0"	10 1/2"	#5 @ 5 1/2"	#5 @ 8"
14'-3"	10 1/2"	#5 @ 5 1/2"	#5 @ 8"
14'-6"	10 3/4"	#5 @ 5 1/2"	#5 @ 8"
14'-9"	10 3/4"	#5 @ 5 1/2"	#5 @ 8"
15'-0"	11"	#5 @ 5 1/2"	#5 @ 8"

Figure 1.9.1C

CONCRETE DECK REINFORCEMENT (LRFD DESIGN) with TRANSVERSE BARS ON TOP
Standard Precast Prestressed Concrete members - Simple Spans

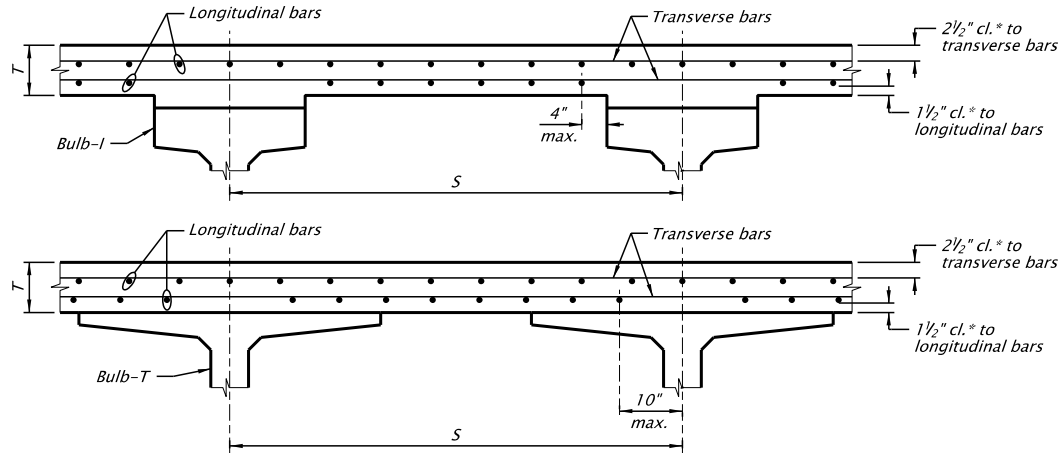

Assumptions:
Specifications: *LRFD 4.6.2.1*

Concrete Class: *HPC 4500*

Reinforcement: *Grade 80*

Top Mat Orientation: Transverse bars on top

Dead Load: 150 pcf + 50 psf future wearing surface

Deck DL moments: Negative $-0.10wS^2$
Positive $+0.08wS^2$

Live Load: *LRFD Table A4-1* using 8" from ϕ of girder to the negative moment design section

Design Moment: $1.25*DL + 1.5*DW + 1.75*LL$
(Impact included in *LRFD Table A4-1* live loads)

Surface Wear: 1/2" allowance for surface wear subtracted from positive moment "d".

Note:
Additional reinforcement to accommodate rail loads at deck overhangs is not included in these details. The designer is responsible for design of overhangs.

Note:
"S" is measured parallel to the transverse bars. Bar spacing is measured perpendicular to the bars.

Place bottom mat bars directly below and in line with a top mat bar. At expansion and construction joints, however, it is not necessary for all bottom mat bars to be directly below a top mat bar.

* For coastal locations, specify 2" clear top and bottom. See also *BDM 1.26.3* for additional corrosion protection recommendations.

Precast Prestressed Concrete Members

Girder Spacing	Deck Thickness	Transverse Bars	Longitudinal Bars
5'-0"	8"	#4 @ 7 1/2"	#4 @ 8"
5'-3"	8"	#4 @ 7 1/2"	#4 @ 8"
5'-6"	8"	#4 @ 7 1/2"	#4 @ 8"
5'-9"	8"	#4 @ 7 1/2"	#4 @ 8"
6'-0"	8"	#4 @ 7"	#4 @ 8"
6'-3"	8"	#4 @ 7"	#4 @ 8"
6'-6"	8"	#4 @ 6 1/2"	#4 @ 8"
6'-9"	8"	#4 @ 6 1/2"	#4 @ 8"
7'-0"	8"	#4 @ 6 1/2"	#4 @ 8"
7'-3"	8"	#4 @ 6"	#4 @ 8"
7'-6"	8"	#4 @ 6"	#4 @ 8"
7'-9"	8"	#4 @ 6"	#4 @ 8"
8'-0"	8"	#4 @ 6"	#4 @ 8"
8'-3"	8"	#4 @ 5 1/2"	#4 @ 7 1/2"
8'-6"	8"	#4 @ 5 1/2"	#4 @ 7 1/2"
8'-9"	8"	#4 @ 5 1/2"	#4 @ 7 1/2"
9'-0"	8 1/4"	#4 @ 5 1/2"	#4 @ 7 1/2"
9'-3"	8 1/4"	#4 @ 5 1/2"	#4 @ 7 1/2"
9'-6"	8 1/2"	#4 @ 5 1/2"	#4 @ 7 1/2"
9'-9"	8 1/2"	#4 @ 5 1/2"	#4 @ 7 1/2"
10'-0"	8 1/2"	#4 @ 5"	#4 @ 7"
10'-3"	8 1/2"	#4 @ 5"	#4 @ 7"
10'-6"	8 3/4"	#4 @ 5"	#4 @ 7"
10'-9"	8 3/4"	#4 @ 5"	#4 @ 7"
11'-0"	9"	#4 @ 5"	#4 @ 7"
11'-3"	9"	#4 @ 5"	#4 @ 6 1/2"
11'-6"	9 1/4"	#4 @ 5"	#4 @ 6 1/2"
11'-9"	9 1/4"	#4 @ 5"	#4 @ 6 1/2"
12'-0"	9 1/2"	#4 @ 5"	#4 @ 6 1/2"

Figure 1.9.1D

Detailing

Wearing surface on cast-in-place concrete decks – New structures with cast-in-place decks will not have an AC wearing surface without a Design Deviation.

If, in rare cases, an ACWS is used, a waterproofing membrane per *BDM 1.26.4* is required. If a Class "F" mix (free draining) is used, special attention needs to be given to drainage details at joints and deck drains to prevent trapping water adjacent to these areas.

Occasionally there are requests to install thermal ice-melting equipment on bridge decks or problematic sections of highway. Bridge Section recommends against these installations unless there is a natural source of warm water at the bridge, as exists in the city of Klamath Falls. All other installations in Oregon have been turned off due to overly expensive power bills and/or early failure of key components. A Design Deviation is necessary to install a thermal system on a bridge deck. Contact the Bridge Preservation Unit for further information.

For typical deck steel placed in two mats, place bottom mat bars such that each bottom mat bar is directly below and in line with a top mat bar. At deck expansion joints and at deck construction joints, however, it is not necessary for all bottom bars to be directly below a top bar.

Inlaid Durable Striping on Bridge Decks – Concrete deck surface removal of up to ¼ inch is acceptable for placing longitudinal inlaid striping on new bridges. Placement of such striping will likely reduce wear at stripe locations. In nearly all cases, the majority of wear for concrete bridge decks occurs within the travel lane. Therefore, it is unlikely ¼ inch maximum removal will significantly impact bridge load capacity.

Allow concrete removal using a diamond grinder according to *SP 00503*. Note that *SP 00503* also permits removal by micro-milling and by hydroblasting. However, only allow diamond grinding for striping applications. Note that *SP 00850* also requires diamond grinding equipment for installation of inlaid/grooved pavement markings.

Do not allow inlaid striping on concrete decks where the striping would be placed in the transverse direction. Concrete removal for such striping would reduce the load capacity of the bridge.

Do not allow rumble strips on concrete bridge decks.

For existing concrete bridge decks, allow inlaid striping only in the longitudinal direction and in locations where there is no significant rutting or other deck wear.

Allow raised pavement markers on concrete bridge decks only when they can be installed without removal of any deck concrete (no grooving).

For existing asphalt concrete wearing surfaces, grooving up to 5/8" depth for striping (longitudinal or transverse) or rumble strips is acceptable.

Limit the use of stay-in-place forms for decks as required in *BDM 1.5.6.2.1*.

Vibrations

Vibrations from adjacent traffic and/or construction activity are not likely to cause cracking in freshly placed deck concrete. One ODOT project recorded vibrations up to 0.6 in/sec during a second stage deck placement with only minor deck cracking near the closure area. Typical deck closure placements may have even higher vibrations. For this reason, minor cracking can be expected in deck closures placed under traffic. However, this cracking rarely results in long-term maintenance concerns. See the "Deck Closure Pours" discussion below for a discussion of closure pour options.

The following is a very rough guide to vibration levels:

0.08 in/sec	vibrations perceptible
0.1 in/sec	continuous vibrations may begin to annoy people
0.2 in/sec	short-term vibrations may begin to annoy people
0.4 to 0.6 in/sec	typical max. short-term vibration, concrete bridge < 100 foot span
0.6 to 1.0 in/sec	typical max. short-term vibration, concrete bridge > 100 foot span

Although damage to concrete due to vibrations is rare, it is good practice to avoid unnecessary vibrations where reasonable measures can be taken. For staged construction, providing deck closure segments is preferred to minimize both vibrations and the effects of adding additional deck dead load, creep and shrinkage to the first stage.

Providing either a joint or closure segment between substructure (cap) stages will also reduce potential for traffic vibrations to be transmitted through those elements.

Where there is a concern that vibrations may be excessive, the following practices can be considered as mitigation:

- Low-slump concrete – Although concrete damage due to vibrations is rare, use of low-slump concrete (greater than 4 inches) will minimize the risk. ODOT's HPC deck concrete mix is generally a low-slump mix that meets this requirement. Therefore, generally no change to the standard HPC deck concrete mix is necessary.
- Reinforcing details – Do not use hooked bars in closure segments. Ensure lap splices are in contact and well-tied as much as possible. Where lap splices cannot be in contact, use two rows of longitudinal bars tied to both lap splice segments to create a rebar mat that cannot be easily moved.
- Retarder admixture – Varying amounts of set retarder admixture can be used such that the entire deck will set up at about the same time. The Structure Quality Engineer from the ODOT Construction Section can assist in determining when this admixture is needed and how to apply it.
- Reduce vehicle speed – Where vibration is due to adjacent traffic, reducing vehicle speed will generally reduce the amount of vibrations. However, vehicle speeds will generally need to be reduced down to around 15 mph before a significant reduction in vibrations can be obtained. Therefore, only consider this measure in extreme circumstances. Where possible, moving traffic laterally from an adjacent deck placement will likely be more effective than reducing vehicle speed.

Deck Closure Pours

Where deck closures are placed under traffic, minor cracking within the closure can be expected. This cracking is typically minor and does not result in significant long-term maintenance. The amount of cracking expected will be a function of the traffic induced vibrations at the site.

The use of Polypropylene fibers are required in all portions of the deck, including the deck closures.

1.9.1.1 Precast Concrete Deck Panels

Standard details are available for precast concrete deck panels to be used with precast concrete girders and steel girders. Bridge deck construction can be accelerated by using precast deck panels. At the same time, deck quality can be improved compared to CIP deck construction since precast deck panels are fabricated under factory-controlled conditions. The current standard details for precast deck panels limit the maximum deck panel length to 50 feet and the effective width to 10 feet. These dimensions are limited by shipping weight and maximum shipping width (assuming panels are placed flat).

To make deck panels fit on a bridge span, provide either CIP end segments or precast exterior deck panels (end pieces). CIP end segments can accommodate construction tolerances; variations; and are a better

option for most cases. For a precast option, a different panel width may be required. When deck panels are post-tensioned, end pieces may need to be thickened to accommodate post-tensioning anchorages.

Prestressed reinforcement is typically used on the long side of deck panels that span between the bridge girders. This is the main reinforcement that provides flexural strength for resisting applied loads during shipment, erection, superimposed dead load, and vehicular live load. Panel thickness may be increased to accommodate final surface grinding and reinforcement detailing.

Deck panels can accommodate skew, superelevation, slight horizontal curve, and vertical roadway profile. For a mild vertical roadway profile, a flat layout of deck panels constructed on bridge girders is adequate and makes the construction of joint connections easier. When the vertical roadway profile is significant, chorded deck panels are recommended to fit the profile with CIP reinforced concrete joints connecting the deck panels. Reinforcement and anchor bolts for bridge railing can be cast into the deck panels as well.

Two possible types of transverse joint connections are CIP reinforced concrete and longitudinal post-tensioning along the length of the bridge. Each connection type has its own advantages and disadvantages.

1.9.1.1.1 Cast-in-place Option

For CIP joint connections, Ultra High Performance Concrete (UHPC) is the preferred material due to its superior bond properties, durability, compressive strength, and tensile strength. There are a number of proprietary UHPC products on the global market, such as BCV®, BSI®, CRC®, Densit®. The only satisfactory UHPC joint material available on the domestic market is Ductal® JS1000 by Lafarge North America, Inc. Since use of this material would be considered a “sole source”, a finding of public interest letter (with approval from FHWA) must be secured before going to bid. In the past there was also an issue with steel fibers used in the Ductal® JS1000 product since the steel fibers were manufactured in Europe and therefore did not meet the “Buy America” provisions for steel. Based on an FHWA Policy Memorandum published on February 12, 2014, steel fiber reinforcement, as used in the Ductal® JS1000 product, is now produced by Bekaert Corporation at a production facility in Rome, GA and commercially available to all potential purchasers. For other UHPC products made outside the USA, they would be able to meet the “Buy America” requirements as long as they used the steel fibers from the Rome, GA facility.

Note also that there are other types of steel fiber reinforcement that are made in the USA. However, at this time only those from the Rome, GA are thought to meet the size and shape needed for the UHPC application.

Due to the nature of new superior materials, UHPC is much more expensive than conventional concrete. Based on an FHWA publication, FHWA-HRT-13-100 published October 2013, the commercially available product by Lafarge is sold for about \$2000/yd³. This price includes material cost of the proprietary blend and fiber reinforcement, as well as costs associated with development and delivery. The same publication also reveals that there are a number of researchers, who have conducted testing programs to develop non-proprietary cost-effective UHPC mixes, which meet all the requirements for UHPC. All materials used in the research project were locally available in three regions across the U.S. One of the material sources is from the Pacific Northwest area. The result shows that it is possible to produce UHPC under \$1000/yd³ using these domestic materials with a non-proprietary blend. Note that the fiber reinforcement is responsible for one half the total cost.

With the excellent bond behavior provided by UHPC, a non-contact splice length for rebar extending out from deck panels is significantly shorter than that required in conventional concrete. To ensure good bonding against precast deck panels, pre-wetting the interface and an exposed aggregate finish is recommended. FHWA Research, Development, and Technology published FHWA-HRT-14-084 in October 2014. This document provides substantial information regarding design and construction of UHPC.

1.9.1.1.2 Post-Tensioning Option

Two post-tensioning options are recommended, i.e. grouted keyway and match cast joints. During the design, a point of no movement and the direction of the movement due to post-tensioning need to be identified and accordingly detailed on the bridge plan. Compressive stresses from post-tensioning in positive bending zones need to be accounted for in the composite section. Placing PT ducts at the CG of the deck panel section is ideal, so that camber or deflection of deck panels do not occur after post-tension. When there are geometric constraints that prevent locating PT ducts at the CG of the section, the movement after post-tensioning needs to be considered in the design or provide hold-down devices to maintain the deck panel position.

(1) Grouted keyway

This post-tensioning option includes deck panels constructed with shear key edges, erected on girders having a 1-3/4 inch wide space, filled with keyway grout, and then post-tensioned together. The grouted keyways are similar to the joints between precast prestressed slab and box girders. Post-tensioning ducts are spliced in pockets with an air and water-tight seal. All splicing pockets and keyways need to be filled with grout and gain specified strength before the post-tensioning operation to ensure continuous flow of the compressive force.

(2) Match cast

The other recommended post-tensioning option is match casting. Deck panels are match cast at the precaster site. Each deck panel is identified, delivered to the site, and erected in sequence as an erection plan. Duct couplers used in precast segmental construction are recommended. With a proper installation, this type of duct couplers provides a continuous, air, and water tight seal. In the U.S. a number of PT suppliers can provide segmental-type duct couplers. Historically only a few suppliers have furnished post-tensioning for bridge construction projects in Oregon. Verify coupler availability before a project goes to bid. Since duct coupler dimensions vary from different suppliers, detail deck panels to fit all possible duct couplers.

Applying epoxy at deck panel interfaces is recommended before post-tensioning. As each deck panel is added, temporary post-tensioning is used to secure the new panel to previously installed panels until the epoxy begins to set. The epoxy serves as a lubricant during placement of the deck panels, prevents water intrusion, and provides some tensile strength across the joint. This construction technique reduces the number of pockets in the finished deck panels.

1.9.1.1.3 Leveling Bolts

Leveling bolts are used to place deck panels to the appropriate elevation before duct splice openings and joints are filled with concrete or grout. During erection of deck panels, leveling bolts are required to rest on all supporting girders to ensure proper load distribution. Steel plates placed on top of precast concrete girders under the leveling bolts are recommended to accommodate deck panel erection. Leveling bolts may be removed or left in place by cutting down the top 1-1/2 inch minimum below the finish surface. Fill leveling bolt holes with non-shrink grout.

1.9.2 Deck Screeding

General

Consider deck constructability issues when specifying deck screeding requirements.

If the deck width or skewed dimension causes the length of the screed equipment to be excessive (more than 100 feet), the deck may need to be placed in stages with or without a closure pour. Where staging is shown on the plans, place a longitudinal joint along a longitudinal beam line and not in a wheel line. Consider this in the beam layout.

Also on skewed decks, a sharp vertical curve on the structure may cause problems with screeding on the skew. It may be necessary to perform some unique sequencing, such as preloading the deck with plastic concrete far enough ahead of the screed machine to preload the beams to get unison deflections and allow the screed to run normal to the beams.

Consider whether the finishing machine can follow the actual slope of the roadway in one placement. Deck screeds can accommodate a crown section in one placement, full width, if the superelevation remains constant. If the superelevation rates vary, the deck will normally need to be placed in separate placements. As noted previously, it is best to have a longitudinal joint along a longitudinal beam and to consider this in the beam layout.

If a structure has different skews at adjacent bents, base the skew of the screed equipment on the average of the bent skews.

If a structure is curved with radial bents, the screed equipment and deck placement remains normal to the roadway centerline. In this case, the screed equipment must be equipped with variable speed capacity at both ends.

Perform sufficient geometric calculations to determine the best method or direction of deck screeding. When necessary, place the required sequencing and/or direction of screeding, skewed or normal, on the detail plans.

Beams not Supported by Falsework

The main concern of this type of placement is that the beams deflect equally in unison, so deck thickness and clearances end up as shown on the plans. To deflect equally the beams need to be loaded equally. Thus when the structure has a skew, the screed should run on a skew, parallel to the bents.

Add a note to the plans specifying that the screed equipment shall run parallel to the bents.

Falsework Supported Beams

There is less concern regarding how the concrete is placed for falsework supported beams. There will still be a small amount of falsework crush due to the added dead load of the deck. Ideally it would be best to place and screed skewed decks on the skew, but practically it is not required.

1.9.3 Deck Construction Joints

Minimize the number of deck construction joints to avoid potential leaks through the deck. However, it is often necessary to provide deck construction joints to avoid shrinkage or deflection cracking.

Normally for non-continuous spans, deck concrete placements are full length or stopped at a transverse beam. The construction joint surface is normally vertical and roughened, according to *SP 00540.43(a)*, between placements.

For continuous spans or for emergency situations, provide a shear key with a roughened surface between placements. Show typical key details on the plans as detailed below.

Provide a roughened surface by using a concrete surface retarder from the QPL in accordance with 00540.43

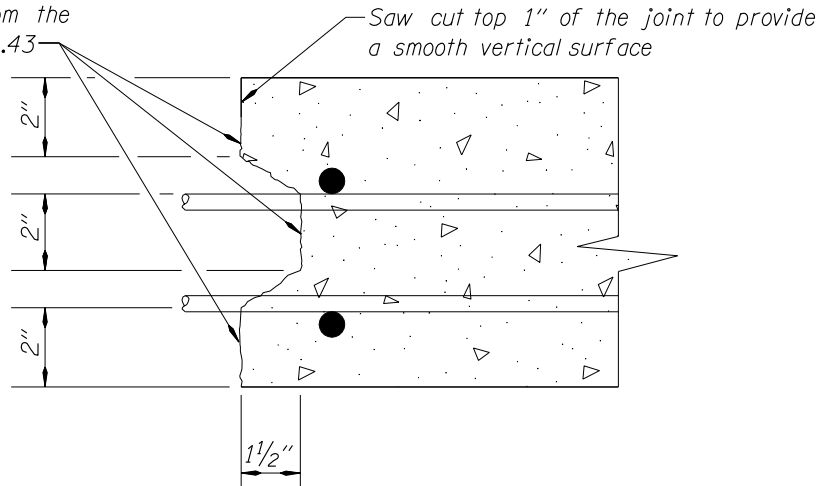

Figure 1.9.3

1.9.4 Deck Overlays

1.9.4.1 Introduction

The purpose of an overlay on a bridge deck can be to:

- restore the structural integrity of the deck
- improve the load capacity
- improve or restore rideability
- improve skid resistance
- improve deck drainage
- improve deck cross-section
- seal deck cracking
- provide sacrificial wearing surface

There are 3 overlay categories available for use on bridge decks:

- Structural Concrete Overlays (SC)
- Polymer Concrete Overlays (PC) – Including Multi-Layer Polymer Concrete Overlay (MPCO) and Premixed Polymer Concrete (PPC)
- Asphalt Concrete Wearing Surface (ACWS)

The term "structural" is used to describe an overlay that is rigid enough and thick enough to increase the stiffness of the deck and decrease live load deflections. SC overlays are typically placed on a bridge deck with a minimum thickness of 2 inches. Include the structural overlay in the stiffness and capacity calculation. SC overlays typically have a compressive strength and elastic modulus similar to conventional concrete, but it may vary depending on the specific product used. Do not include the top ½ inch of overlay in the structural deck thickness, since it is considered a sacrificial wearing surface.

Polymer Concrete (PC) is used in special situations where structural integrity is not an issue and does not add to the deck stiffness.

ACWS may only be used with membrane waterproofing. Use ACWS only on bridges with existing ACWS.

Consider the option of replacing the ACWS with another overlay type, where roadway ACP depths allow.

ACWS does not add to the deck stiffness and is not considered to be a "structural" overlay..

Overlay selection is discussed further in BDM 1.9.4.7.

1.9.4.2 Structural Concrete Overlays

SFC, often referred to as Microsilica Concrete (MC), has been the most common structural overlay type for the last decade. Due to problems with cracking, High Performance Concrete (HPC) overlays are now preferred. HPC is a similar mix to SFC, but uses larger aggregate, among other changes, to reduce cracking.

Other structural overlay materials include High-Early and Latex Modified. Specification of these overlay types requires a Design Deviation.

Review [SP 00559](#) for structural overlay requirements and restrictions.

Commentary:

SFC is a specialized concrete mix with a silica fume modifier. Batching is normally done at a batch plant. SFC placement is accomplished with more conventional construction methods.

Latex Modified Concrete (LMC) is a concrete mix with a latex emulsion modifier. The latex emulsion has a milky color and texture and is added during batching. Batching is done in mobile mixers at the job site.

LMC overlay technology has been used since 1958, and the design life of the material can be predicted from historical data, but it has not been used in Oregon for many years.

The use of LMC offers many construction advantages. Since the material is batched in a mobile mixer, the pour schedule does not depend upon the concrete plant schedule. Also, the pour is not influenced by the projects distance from the concrete plant. LMC was a common type of structural overlay in the past. Equipment may be available, but verify with local contractors before specifying LMC.

LMC does have some disadvantages, however. Placement of the LMC overlay is very labor intensive, increasing construction costs. The rate of construction for an LMC overlay is about 6400 sf to 7400 sf per 8-hour work shift. LMC is also very sensitive to atmospheric conditions which often control not only the pour schedule but the contract time as well. Review [SP 00559](#) for placing limitations. Surface preparation and curing are the most critical factors to achieving a good quality end product and are often the most neglected.

1.9.4.3 Polymer Concrete Overlays – General

Polymer is a very general term used to classify a wide variety of compounds that chemically combine in a reaction (polymerization).

Polymer binder resins are formulated in hundreds of different combinations, depending upon the properties desired. The most common categories of polymer binder resins in use as bridge deck overlays or patching material include:

- Epoxy
- Polyester

PC is a composite material in which coarse aggregate is bound together with the polymer binder resin.

PC can be placed as an overlay in generally two different ways – as a MPCO (also known as broom and seed) or as PPC, which is screed finished to grade.

The most common polymer used for MPCOs is epoxy.

The most common polymer used for PPCs is polyester.

PC overlays have many construction advantages:

- PC overlay flexibility reduces the potential for cracking due to thermal or design load movement.
- PC overlays are very light as compared to SC overlays. This reduction in dead load can be significant on load posted bridges or movable bridges.
- PC overlay construction time is much less compared to SC overlay applications. The short construction time provides a great advantage in time critical urban areas.
- PC overlay bond strength is typically double that of an SC overlay.

PC overlays also have some construction disadvantages:

- Atmospheric conditions: The prepared deck surface must be dry prior to placement. This provision could influence construction schedules. For off-season applications, SP 00556 and SP 00557 provide guidance for Inclement Weather Plans, which can involve heating the bridge deck to force it to dry. This will impact traffic control requirements and costs, so avoid scheduling PC overlays for winter applications when possible.

1.9.4.3.1 Multi-layer Polymer Concrete Overlays

MPCO's are a composite material formed by combining polymer binder resin and coarse aggregates.

MPCO's are constructed using any of the commonly available polymer resins. Each resin has its own advantages and disadvantages and should be used in accordance with manufacturer's recommendations.

MPCO's have a significantly lower modulus compared to PCC and therefore cannot be considered a "structural" overlay. MPCO's have been used on the interstate and appear to be performing well. MPCO's are typically placed to a nominal 3/8" thickness.

MPCO's applications don't require specialized equipment and are well suited for maintenance crews and smaller contractors. There have, however, been advances in application methods which have increased application efficiency vs. traditional manual application methods.

MPCO aggregates have a tendency to polish in the wheel lines, potentially reducing skid resistance as compared to other overlay types. Avoid high traffic volume locations when selecting MPCO's. Consult with the bridge maintenance engineer for additional guidance.

A typical MPCO is constructed by first removing all dirt, debris and laitance on the deck surface. This is best accomplished with the use of a shot blast system. Since the deck surface must be clean and dry prior to the application of the MPCO, the industry recommends the use of the shot blasting method. Shot blasting leaves the surface dry and vacuumed.

A layer of polymer is next applied to the prepared deck using a squeegee, broom, spray bar or other methods at a rate specified by the manufacturer. The aggregate is then broadcast, at a specified rate, over the surface. The excess aggregate is swept off the surface. Apply lifts according to manufacturer's directions to achieve a nominal 3/8" thickness. Place additional MPCO material in ruts to provide a finished MPCO surface that is

free of ruts, depressions, and irregularities.

Application rates can be estimated from between 2000-4000 square feet/hr.

The finished MPCO surface is not tined or screeded.

Refer to either the Conditional Products List or the *Qualified Products List* for MPCO products that are being evaluated for approval or have been approved for use. MPCOs and MPCO Aggregates are listed separately on the QPL. The MPCO binder manufacture is required to select the appropriate MPCO Aggregate from the QPL. *SP 00556* covers the use of MPCOs.

1.9.4.3.2 Premixed Polymer Concrete Overlays

PPC is a composite material formed by combining polymer binder resin and coarse aggregates in a mobile mixer, then applied to the deck and screed finished to grade.

PPC has a significantly lower modulus compared to PCC and therefore cannot be considered a “structural” overlay.

PPC overlays have been used on the interstate and appear to be performing well. Preliminary numbers indicate a slight advantage over MPCO’s in skid resistance.

PPC overlays are typically placed to a nominal 3/4” thickness and are more appropriate for minor grade improvements than MPCO’s, due to the grade controls of the screed finish machine. Due to the increased material thickness, PPC overlays are more expensive than MPCO’s.

PPC is rapid setting and is best placed with a screed finish machine whenever practical. There are circumstances where a screed cannot be used, such as along the gutter lines which will require manual finishing. Application rates can be estimated at a maximum of 5000 square feet/hr. Unit weight of PPC is typically 135 pcf.

A typical PPC is constructed by first removing all dirt, debris and laitance on the deck surface. This can be accomplished with the use of a shot blast system. Since the deck surface must be clean and dry prior to the application of the PPC mixture, the industry recommends the use of the shot blasting method over the others. Shot blasting leaves the surface dry and vacuumed.

A layer of primer is next applied to the prepared deck surface using a squeegee or brooms. Next the polymer resin binder is mixed with the other components into a premixed condition. The premixed material is then placed onto the primed surface and finished to grade with specialized equipment designed for PPC applications. Silica sand is broadcast in areas of high resin content to maintain skid resistance.

The final product looks similar to PCC but with longitudinal tining.

PPC is currently not listed on the QPL and needs to be specified accordingly. Special Provision *00557* covers the use of PPC.

1.9.4.4 Field Investigation

Upon receiving a project assignment, review the latest bridge inspection report, noting the ratings for the deck, superstructure, bridge rails, deck joints and deck drains. A site visit may also be needed to gather additional information. Obtain guidance from the Corrosion Engineer and, per their guidance, core the deck and test for chloride levels or other chemicals of interest. In rare cases, additional cores may be required for compressive strength testing or to perform petrographic analysis.

Use rebar detector to locate existing deck reinforcement. Avoid coring through existing rebar.

For chloride testing take minimum 4-inch diameter cores with minimum 4.5 inches long. Take a minimum of 4 cores at a frequency of a pair of 2 cores for every 10,000 square feet of bridge deck. For each pair include one core within a wheel track/rut and one core between wheel track/ruts. Sampling a single lane of a multi-lane structure is often sufficient.

Test all cores for chloride analysis according to ASTM C1152 or AASHTO T260 in 0.5 inch increments to a depth of 2.5 inches below the surface of the concrete or the bond line between overlay and substrate materials. Typically, an additional 2 inches below the deepest test is necessary to cut and pulverize the core for testing. For thin decks or thick overlays where 2.5-inch depth testing is not practical, test as many sample depths as possible without taking a full depth core.

Spread locations of coring evenly throughout the surface area of the deck without causing major traffic interruption. Avoid coring at locations where worker and public safety is compromised. Repair core locations with a rapid setting repair mortar from Section 02015.20 of the QPL.

1.9.4.5 Warrants for Overlays

Use the following overlay criteria and engineering judgment to determine whether an overlay is warranted.

- Bridge deck overlays are **not** recommended if any of the following conditions are met:
 - The deck condition is rated as a 7 or greater (category 3) in Item 58 of the bridge inspection report. The deck is still in good condition.
 - Delaminated, patched or cracked areas are less than 1 percent of the deck area. The deck is still in good condition.
- Bridge deck overlays are **not** recommended, and deck replacement should be considered, if any of the following conditions are met:
 - The deck condition is rated as a 4 or less (category 1) in item 58 of the bridge inspection report and any additional investigation confirms that the deck deterioration has become too severe to repair.
 - Delaminated, patched or cracked areas are greater than 15 percent of the deck area and any additional investigation confirms that the deck deterioration has become too severe to repair.
 - Corrosion has deteriorated the deck to an extreme level or the chloride content exceeds 0.040 percent by mass of sample at the depth of rebar. See "Corrosion Considerations" below.
- Bridge deck overlays **are** recommended if any of the following conditions are met:
 - The deck condition is rated as a 5 or 6 (category 2). See item 58 of the bridge inspection report.
 - The deck condition is rated as a 4 or less (category 1) in item 58 of the bridge inspection report and thorough investigation shows that the deck deterioration has not become too severe to repair.
 - Delaminated, patched or cracked areas are greater than 15 percent of the deck area and thorough investigation shows that the deck deterioration has not become too severe to repair.
 - Delaminated, patched or cracked areas are greater than 5 percent but less than 15 percent of the deck area.
 - Delaminated, patched or cracked areas are greater than 1 percent but less than 5 percent of the deck area and the annual average daily traffic (AADT) is at least 3000.

- Delaminated, patched or cracked areas are greater than 1 percent but less than 5 percent of the deck area and the structure carries interstate highway traffic.
- Corrosion has not deteriorated the deck to an extreme level or the chloride content is less than 0.040 percent by mass of sample at the depth of rebar. See "Corrosion Considerations" below.
- MPCOs may be used as a preservation measure on decks in good condition at the request of maintenance.

"Thorough investigation" means a delamination survey of the entire deck and chloride profiles taken from areas of highest exposure to drainage, and requires concrete cores. Chloride content at the surface is not adequate as levels can vary greatly. These results are used to determine the remaining concrete deck integrity before determining the appropriate deck treatment or if deck replacement is warranted.

1.9.4.6 Corrosion Considerations

Determine whether the structure is in a "marine environment". A marine environment is defined in *BDM 1.26.1*.

If the structure is in a marine environment, deck rebar corrosion is visible, or there is other reason to suspect the structure may be occasionally salted during winter months, discuss the proposed overlay project with the Corrosion Engineer in the Preservation Engineering Unit. Replacement of an existing deck may need to be considered depending upon the extent of chloride content and rebar corrosion. If the maximum acceptable chloride level in the deck has been exceeded, deterioration of the deck rebar will continue regardless of the presence of a new overlay.

ACWS with membrane waterproofing

FHWA requires deck surface protection from top down chloride intrusion. Therefore, when ACWS is the only feasible option for overlay, install a waterproofing membrane per *BDM 1.26.4*.

1.9.4.7 Design and Construction Considerations

After determining whether a bridge deck overlay is warranted, consider whether a SC overlay, a PC overlay or an ACWS will be used. Typically, one type will be better suited for the project than the other. Some factors to consider are:

- Short construction time windows (typically in urban areas) favor a PC overlay or an ACWS over a SC overlay due to speed of placement and cure time. LMC requires a 4 day cure time. SFC requires a 7 day cure time.
- Dead weight critical structures favor a PC overlay over a SC overlay or an ACWS because of their thin, lightweight nature. However, contribution of a structural overlay can be included in stiffness and strength calculations of deck sections.
- Decks requiring extensive buildup due to grade corrections or wheel rutting favor a SC overlay or an ACWS over a PC overlay due to the difficulty and cost of building up a PC overlay.
- The construction budget. When the initial cost is a major consideration, ACWS is the least expensive.
- Region/Project Manager's experience. During the Scoping and TS&L design phase, check with Region to see if they have a preference between the different types of overlays.
- SC and ACWS overlays need elastomeric concrete nosings or armored corners at the bridge ends and joints. It may be possible to place a PC overlay and not do any work to the joints.

Bridge Design Manual – June 2020
Oregon Department of Transportation
Section 1 – Design Standards

Check the structure for the possibility of a bridge rail and/or bridge rail transition retrofit or replacement, deck joint repair or replacement, the addition of reinforced concrete end panels, the addition of protective fencing, the need for scour protection, seismic retrofit and bearing repair.

For load restricted bridges, confirm that the weight of the overlay construction equipment will not overstress the bridge. Restrictions may be required on the spacing of a paving train or the size of the milling equipment.

The following chart provides some guidance for selecting an overlay type based on design criteria.

<u>DESIGN CRITERIA</u>	<u>ACWS</u>	<u>MPCO</u>	<u>PPC</u>	<u>SC</u>
Economy - Initial Cost	X			
Construction Time - Fastest	X	X	X	
Grade Correction or Buildup Required	X		X	X
Dead Load Limitations		X	X	
Deck Sealer for Corrosion Protection		X	X	X
Proven Longevity				X
Low Traffic Volumes	X	X		
Deck Crack Sealer		X		

During the overlay selection process, review the structure's "As Constructed" plans, paying special attention to the following items:

- Effect of Additional Dead Load - Typically the dead load from a 2 inch concrete overlay has little effect on the capacity or operation of the structure. Exceptions to this are load posted bridges or movable bridges, where a SC overlay's dead load may have a significant impact. A thinner or PC overlay may be required.
- Existing Bridge Rail – Review the existing bridge rail for functional adequacy and replace if unacceptable (see *BDM 1.13*). Check the dimension from the top of the rail to the overlay finish grade to make sure that the minimum rail height is still met.
- Deck Joints – Clean and repair deck joints (if necessary) prior to placing the overlay. Review the Bridge Inspection Report or field notes for information to determine if any deck joint work is needed. Additionally a field trip may be necessary in order to determine the best type of joint repair or replacement. See Standard Joint Drawings for typical deck joint reconstruction details. See Standard Specifications and *SP 00585* for expansion joints. Asphaltic Plug Joint Seals must be replaced when overlay thickness exceeds 3/8 inch.
- Elastomeric concrete nosing is recommended for SC overlays, because of the high incidence of debonding at expansion joints or at bridge ends. See *SP 00584* for specifications developed for concrete nosing.
- Deck Drains – Note existing deck drains on the overlay plan view. Generally, raise deck drain grates to match the new deck surface. For a PC overlay, the existing deck drain taper is adequate. Verify if deck drain grates need to be upgraded for bicycle safety. See *BDM 1.24* for additional information about bridge drainage.
- Bridge End Panels - The need for bridge end panels can be confirmed by reviewing the current Bridge Inspection Report and the Maintenance file records. A field trip may be necessary to determine whether or not adding end panels to the structure is the best choice to minimize pavement cracks and/or settlement at the bridge ends.
Bridges constructed after 1960 generally have paving ledges at the bridge ends, even though end panels were not installed at the time of construction. For older bridges, without paving ledges, or for bridges with paving ledges that are too small, new corbels will need to be detailed to provide support for proposed bridge end panels.

Traffic restrictions may require staging of the end panels or the use of Type III cement (high-early strength concrete) to accelerate construction times.

See *BDM 1.23* and *SP 00545* for additional information about bridge end panel design.

Check for the presence of an existing overlay or wearing surface. If one is present, note what material type it is. Also, check for the presence of an existing waterproof membrane. Some Oregon bridges may have asbestos containing membranes, which require additional testing and care during removal. This information is used in estimating unit costs for Deck Preparation. Use *SP 00504* for removal of existing overlays and membranes.

There is a statewide priority list for protective fencing. Since the 1993 law (ORS 366.462) which required all freeway overpasses and overcrossings over facilities with 4 or more lanes to have protective screening is still in effect, if a structure to be overlaid crosses over a roadway and does not have existing protective screening, consult with the Bridge Program Manager during Scoping to determine whether screening is appropriate to include with the overlay project.

SC Overlay Depth:

On SC overlay projects, adjust nominal overlay depths according to the following guidelines:

- For depths of 2 to 3 inches: use a full depth SC overlay with no added reinforcing.
- For depths between 3 to 4 inches contact the Bridge Standards Engineer for options to decrease shrinkage.
- For depths 4 inches or greater: provide shear dowels from existing concrete to improve bond according to *Figure 1.9.4.7A*.

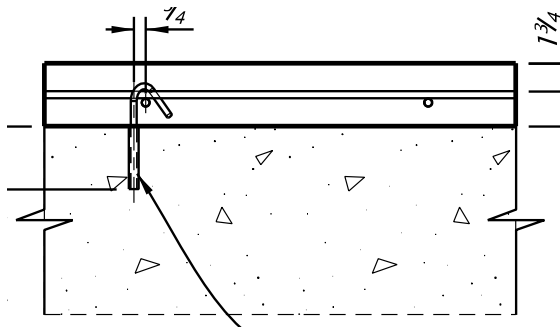

Figure 1.9.4.7A

- For depths greater than 5 inches, include both shear dowels and temperature reinforcing steel. Dowels are designed for shear loading only.

1.9.4.8 [Removed]

1.9.4.9 TP&DT / Stage Construction

Temporary protection and direction of traffic (TP&DT) requirements are important design considerations and could control project cost, project scheduling and, as a result, the type of overlay. Urban projects or narrow roadway width structures may require very short overlay cure times that could limit the use of a SC overlay. Discuss traffic control issues early in the project with both Region and the Traffic Control Designer.

When stage construction is proposed, arrange the stage construction widths so that the overlay can be constructed in widths between 6 feet and 30 feet which are comfortable widths for SC overlay finishing machines and placement of PC overlays or ACWS. Avoid placing longitudinal construction joints in the wheel paths.

1.9.4.10 Quantity Estimates

All overlays require the use of SP 00504. Bridge decks with existing ACWS also require SP 00503.

Use any necessary removal bid items, depending on the existing bridge deck surface. All existing overlay removal is measured by square yard. If the ACWS is too thick to be removed in one pass (i.e. greater than 2 inches), increase the unit cost for the additional passes required. For structures with ACWS, core samples may need to be taken to determine the thickness. Identify any membranes present during coring operations. Bonded waterproofing membranes, such as spray-on or polymer membranes have an additional bid item in SP 00504 for removal. Fabric membranes are removed as incidental to SP 00503.

Once the existing overlay or membrane is removed, the deck is prepared per SP 00504. Class 1 Preparation takes place in areas where no additional concrete removal is necessary to reach sound concrete. This level of preparation is not measured and payment for it is included in the construction of the new overlay.

Class 2 Preparation is any removal of unsound concrete that does not extend the full depth of the deck. It is measure by the square yard. The repair method and pay item for Class 2 preparation varies depending on the new overlay type.

Class 3 Preparation is any removal that extends through the entire deck. Class 3 Deck Preparation is usually required due to severe deep delaminations, a severely cracked deck in all directions, a badly spalled bottom deck or poor aggregates. In most cases, the quantity of Class 3 Deck Preparation is very small. If so, no bid item is necessary. The work will normally be performed on an extra work basis.

If there is a known quantity, a separate bid item should be used. The quantity should be estimated after consulting with maintenance and the bridge inspector. A field visit may be required. Additional Class 3 Deck Preparation beyond the known quantity can then be paid for as extra work.

A deck survey is required to confirm the estimated quantity of both Class 2 and Class 3 Deck Preparation. Visual inspection and sounding (e.g. chain drag) are the primary methods for determining quantities. Advanced non-destructive evaluation (NDE) methods, such as infrared scanning, impact echo, or ground penetrating radar (GPR) have been used in limited, high-risk, environments. Consult with Structure Services prior to using advanced methods.

A typical SC overlay for a bridge deck consists of the following structure bid items in addition to any Removal items:

- Class 2 preparation for SC Overlay Installations (per sy)- SP 00504

Bridge Design Manual – June 2020
Oregon Department of Transportation
Section 1 – Design Standards

- Furnish Concrete Overlay (per cy) – SP 00559
- Construct SC Resurfacing (per sy) – SP 00559
- Saw Cut Texturing (per sy) – SP 00559

Class 1 Deck Preparation, which is not paid or measured separately from the overlay placement, includes roughening the surface to a surface texture depth profile of 1/8 in.

Furnish Concrete Overlay – Calculate this quantity from the Class I deck preparation area and a depth of 1/2 inch greater than the specified minimum depth. This increase accounts for field quantity overruns due to minor grade corrections and irregular Class 1 deck preparation. If Class 2 deck preparation has been identified, add that quantity into the "Furnish Concrete Overlay" total. Work with the Roadway Designer to confirm that the 3D model, if available, and roadway finish grade profile match the estimated overlay quantities.

Construct SC Resurfacing - This quantity is typically measured for gutter to gutter and end joint to end joint.

A typical PC overlay for a bridge deck consists of the following structure bid items in addition to any Removal bid items:

- Class 2 Preparation (per sy) – SP 00504
- Furnish MPCO Material (per sy) – SP 00556
Or
- Furnish PPC Material (per cy) – SP 00557
- Construct PC Concrete Overlay (per sy) – SP 00556 or SP 00557

Deck Preparation - Deck preparation for PC overlays is constructed per SP 00504. Class 1 Preparation for PC Overlays requires roughening the existing deck to a 1/16" surface texture profile depth. Class 2 Preparation for PC Overlays includes repairing the deck with a PCC repair material at least 5 days prior to placing the overlay.

Furnish PC concrete overlay – Calculate this quantity from deck area (gutter to gutter and end joint to end joint) and a depth of 1/8 inch greater than the specified nominal depth.

Construct PC concrete overlay – Calculate this quantity from the deck area (gutter to gutter and end joint to end joint).

A typical ACWS for an existing bridge deck consists of the following bid items:

- Bridge Deck Cold Plane Pavement Removal (per sy) – SP 00503
- Class 2 Preparation (per sy if needed) – SP 00504
- Membrane waterproofing (per sy)
- Asphalt concrete mixture (per ton)

The Membrane Waterproofing bid item includes full compensation for applying the membrane waterproofing system and the asphalt tack coat.

The asphalt concrete bid item is typically the responsibility of the Roadway Designer. Communicate with the Roadway Designer to make sure all the bid items are covered.

In addition to these bid items, the following items may also be required:

- Deck joints (each or linear feet)
- Deck drain construction (each)
- Bridge rail retrofit or replacement (linear feet)
- Reinforced concrete end panels (per sy)

1.9.4.11 Preparing Plans and Specifications

Use detail reference notes to indicate the overlay construction work required and other work, such as:

- Construction of end panels.
- Construction of paving ledges.
- Deck drain raising locations.
- Expansion joint work.
- Bridge rail retrofit or replacement.
- Bridge rail transition retrofit or replacement.
- Protective fencing.
- Stage construction (coordinate with the Traffic Control Plans Unit).

Miscellaneous details may need to be added to clarify the work to be done in specific areas. These details can be placed on the plan sheet or a second sheet if more space is required.

If stage construction is used, temporary concrete barrier may be required on the bridge deck. Check with the Traffic Control Designer for recommendations. See *BDM 1.13.1.10* for temporary barrier detailing and anchorage requirements.

Indicate in the "Designer's Notes to Specifications" under which bid item the miscellaneous details are to be paid for. Expansion joints and deck drain work may be paid for under the bid item for overlay construction if the cost is minor. End panels, paving ledges, bridge railing and protective fencing will need separate bid items.

1.10 FOUNDATION CONSIDERATIONS

[1.10.1 Foundations, General](#)

[1.10.2 Lateral Earth Restraint](#)

[1.10.3 Underwater Construction](#)

[1.10.4 Foundation Modeling \(Foundation Springs\)](#)

[1.10.5 Foundation Design](#)

1.10.1 Foundations, General

The Geotechnical designer will provide data and recommendations with respect to types of footings, footing elevations, nominal and factored resistances, types of piling, pile tip reinforcing, and drilled shaft tip elevations which are to be used at each bridge site. The Designer should be satisfied that the recommendations are adequate with respect to factored loads and economy. If there are questions in this matter, they should be discussed with the Geotechnical designer. Special factors in the type of construction selected may cause a reconsideration of the original recommendation. Some basic guidelines include:

- If the Geotechnical report is not available, the fact should be noted and the basis for the design of the footings should be indicated.
- Except for special cases, provide a minimum of 2 feet of cover over the top of spread footings.
- Make the top of footings within the right of way of the Union Pacific Railroad a minimum of 6 feet below the bottom of the low rail to allow for future underground utilities.

1.10.2 Lateral Earth Restraint

If passive earth pressures are used in design to resist seismic or other lateral loads, detail the plans to ensure assumed soil conditions exist after construction. Where possible, plans should specify placing footings against undisturbed material. The soil type may be such that it will not stand vertically after excavation. If soil is disturbed, *SP 00510.41* requires backfilling with compacted granular material. If there is any question concerning this, consult with the Geotechnical Designer. If the excavation will not stand vertically, add a reference note, "See Standard Specifications for Construction" to the "Structure Excavation Limits" detail shown on the plans. The Contractor will be allowed to excavate beyond the footing limits and backfill with compacted granular structure backfill (*SP 00510.46*). If footings, such as pile supported, etc., do not require the lateral soil resistance for stability, then do not call for pouring against undisturbed material.

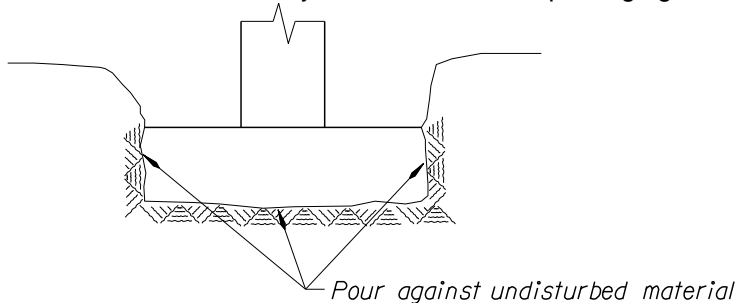

Figure 1.10.2A

1.10.3 Underwater Construction

1.10.3.1 Underwater Foundation Design Considerations

- Requirements for scour protection, potential scour depths and elevations, recommendations for riprap protection can be found in the Hydraulic Report.
- The seal size, which ultimately determines the cofferdam size should be large enough to accommodate the footing plus footing forms inside the cofferdam walers. A minimum of 2 feet on each side of the footing should be provided.
- Require the contractor to remove all underwater formwork.
- In streams where there is a potential for scour, riprap should be placed as soon as possible and before removal of the cofferdam.
- Scour calculations do not take into account debris loading. A pile of debris will cause a larger obstruction thereby increasing the scour depth.
- Streambeds are often "mobile" and the top few feet or so are moving downstream all the time. During extreme flood events the mobile streambed material cannot be counted on for protection.
- The depth component of the bearing resistance equation has the most significant contribution to the footing's ability to support the load.
- Riprap is not considered permanent protection against scour for seals.
- When placing a footing in a stream, the material around and over the footing has been reworked and doesn't have the in situ strength of the native streambed.
- Another factor that is not always taken into account during a scour calculation is that the stream may be degrading or have the possibility of degrading in the future.

1.10.3.2 Footing Embedment

On stream crossings and where horizontal forces are involved, the following sketch should appear on the plans if the foundation material is suitable.

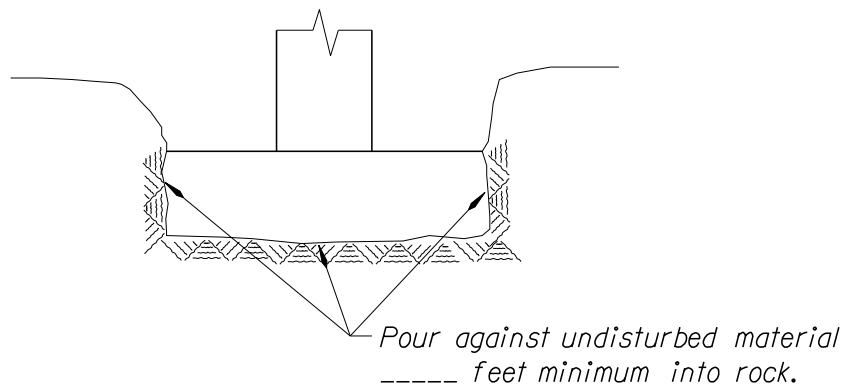

Figure 1.10.3.2A

The bottom of footings in streambeds shall be a minimum of 6 feet below the normal streambed, except in solid rock. If in solid rock, the top of the footing shall be flush with the rock line.

1.10.4 Foundation Modeling (Foundation Springs)

In foundation modeling it is common practice to first assume translational and rotational fixity of the foundation supports and perform a preliminary structural frame analysis. The resulting reactions are checked against the factored resistances. This procedure underestimates global deflections but establishes an upper bound for forces. This type of foundation modeling may be sufficient in certain loading conditions, such as thermal expansion, where deflections are not a controlling factor in design provided the forces are not excessive. However, under higher lateral loading conditions, such as moderate to severe seismic loading, more accurate deflections and forces are desirable. Excessively conservative design forces can be expensive to accommodate. In these cases, foundation springs are typically used in the structural frame analysis. The computer program such as Midas Civil or SAP2000 allows the use of these springs. Foundation springs are typically equivalent linear springs representing the translational (horizontal), axial (vertical) and rotational load-deflection behavior of a nonlinear soil response. The use of foundation springs can significantly reduce the upper bound foundation reactions and more accurately models the entire soil-structure interaction system. Nominal geotechnical resistances are typically used with seismic loading conditions unless otherwise directed by the Geotechnical Designer. Factored resistances are typically used for all other load combinations. Factored resistance is the nominal resistance multiplied by the appropriate resistance factor.

1.10.4.1 General Modeling Techniques

There are three options for foundation modeling:

- (Option 1) Fixed foundations
- (Option 2) Fully coupled foundation spring model
- (Option 3) Uncoupled translation and rotational springs

Option 1 fixes all foundation supports in the computer model. The resulting forces are simply compared to the resistances stated either in the Geotechnical Report or as determined in this section of the design manual. If the resulting forces exceed the resistances, foundation modeling using springs is recommended.

Option 2 allows stiffness coupling for both shear and moment and also cross-coupling (off diagonal). This option is not required for most problems. This option should be used for drilled shafts, trestle piles and for some pile foundations where the piles are connected to the substructure or superstructure such that a fixed condition exists. A massive footing with deeply embedded piles is an example. The method is applicable to all types of foundations.

Option 3 is the most commonly used method to represent footing and piling flexibility. It is a simplified version of the fully coupled spring model (Option 2) and is used in cases where there is no significant moment transfer between superstructure and foundation elements. This option is appropriate for most problems except as noted in Option 2 above. Use this option with vertical piling only. Battered piles result in larger lateral stiffness, which this option does not presently address.

1.10.4.2 General Procedures and Typical Values

The following guidelines are provided for Option 3 as general information, and are intended to be supplemented with engineering judgment. Methods are presented for developing foundation springs, including factored and nominal resistances, for the following foundation types:

- Abutments and wingwalls
- Spread footings
- Piles and pile caps

Foundation springs are typically nonlinear in form although some are represented in bilinear form. The curve typically consists of an initial (straight line) stiffness followed by a nonlinear relationship leading up to a nominal resistance. Various methods are used, depending on the type of spring, to develop the entire nonlinear load-deflection curve (spring).

The procedures described in this section, and typical values, come from the following sources:

- “Seismic Design of Highway Bridges”, Workshop Manual by Imbsen & Associates, Inc., prepared for the FHWA, October, 1989.
- “Design and Construction of Driven Pile Foundations”, FHWA Workshop Manual, Volume 1, December, 1996.
- Design Manual 7.2, “Foundations and Earth Structures”, Dept. of the Navy, May, 1982.
- “Foundation Analysis and Design”, (4th ed.) by Joseph E. Bowles.
- “Design Manual for the Foundation Stiffnesses Under Seismic Loading”, prepared for Washington DOT by Geospectra, April, 1996.
- “Design Guidance: Geotechnical Earthquake Engineering For Highways”, Volumes I & II; FHWA Report No. FHWA-SA-97-076-77, May, 1997.
- Pile capacity and stiffness work done by Bridge Engineering and Geotechnical Group personnel in 1996 and 1997.

Standard Penetration Test (SPT) numbers presented in the Design Manual (“N_c” values) refer to “N” values for granular soils corrected to an effective overburden pressure of 1 tsf. Uncorrected “N_c” values should be used for cohesive soils. The Geotechnical Designer should be consulted for representative values to use in these methods.

(1) **Abutments and Wingwalls:**

Use translational springs in both the longitudinal and transverse directions.

Translational Stiffness:

The abutment **and wingwall** translational stiffness should account for displacements resulting from expansion joints associated with seat abutments.

Initial backfill stiffness, is determined by the backfill of the abutment and wingwalls. Wingwalls should be modeled similar to the abutment. Direction of the wingwall contribution is into the approach fill. The

initial stiffness should be adjusted proportional to the backwall width and height according to the following equation where the height of the backwall is normalized (Maroney 1995).

Use this value for unknown backfill or when the backfill does not meet the requirements shown on DET3160.

$$k_i = \frac{20 \frac{\text{kips}}{\text{in}}}{\text{ft}}$$

When the approach fill is constructed/reconstructed using granular structure backfill and meeting the limits shown on DET3160 the following value for initial stiffness can be used.

$$k_i = \frac{50 \frac{\text{kips}}{\text{in}}}{\text{ft}}$$

The stiffness of the abutment is calculated with the following:

$$K_{abut} = k_i * W * H / 5.5 \text{ft}$$

Where:

k_i = the initial stiffness with units of $\frac{\text{kips}}{\text{in}} / \text{ft}$

W = the width of the abutment with units of ft

H = the height of the abutment with units of ft

Piles: Refer to “Pile Supported Footings and Abutments” (see BDM 1.10.4.2(3) below). Use pile translational stiffnesses in tables below for loading conditions other than seismic. For seismic loading conditions, perform an analysis using soil response program such as LPILE. Consult with the Geotechnical Designer to verify LPILE soil properties.

Translational Capacities:

The passive force resisting the movement at the abutment is modeled using a bi-linear curve with respect to displacement. The ultimate static passive force should be calculated using the following equation. Maximum passive force can only be applied once the soil has been mobilized. Acceptable passive mobilization values are found in AASHTO Table C.3.11.1-1. When the wall is backfilled with a medium dense sand or compacted silt a value of 0.02H (where H is the height of the wall in ft) should be used. When granular structure backfill is used to fill the active and passive wedge a value of 0.01H should be used to determine if mobilization occurs. Only when this deformation is equal to or exceeds this value, then the ultimate passive force can be employed.

$$F_{ult} = WH^2 \frac{5 \text{ksf}}{5.5 \text{ft}}$$

Where:

F_{ult} = the maximum passive force with units of kips

W_{bw} = the width of the backwall in feet

H_{bw} = the height of the backwall and cap in feet

Piles: For seismic loading, use ultimate values derived from LPILE analysis by comparing the maximum yield moment of the pile to the maximum moment output from LPILE. Take end slope and side slope

effects into account. Generally assume dense granular fill representing granular wall backfill. This material should be present in the entire passive wedge area. Consult with the Geotechnical Designer to verify LPILE soil properties. Use allowable pile capacities in tables below for loading conditions other than seismic.

Translational Load-Deflection Curve:

Use the initial stiffness up to the capacity limit. The curve form is:

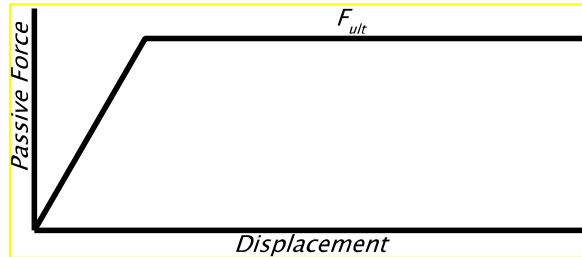

Figure 1.10.4.2-1

(2) Skewed Abutments with Wingwalls:

Recent large scale testing and numerical modeling of skewed abutments with wingwalls parallel with the roadway show a significant reduction in passive pressure as well as increased displacements, and increased bending moment that must be accounted for in design (Rollins and Snow, 2019). When the abutment is skewed the passive force calculated above is further reduced using the following and applied perpendicular to the skewed bent.

$$F_{ult-skew} = F_{ult} * R_{skew}$$

$$R_{skew} = e^{-\theta/45^\circ}$$

Where:

F_{ult} = the maximum static passive resistance.

$F_{ult-skew}$ = the ultimate static passive resistance on a skewed bridge permitted by ODOT.

θ = skew angle of the bridge with units of degrees

R_{skew} = the reduction factor

To allow for modeling of the bridge in the longitudinal direction the ultimate static passive resistance distribution is modified by increasing it at the obtuse corner of the bridge deck by 1.25 and decreasing at the acute corner by 0.75 as shown in the figures below.

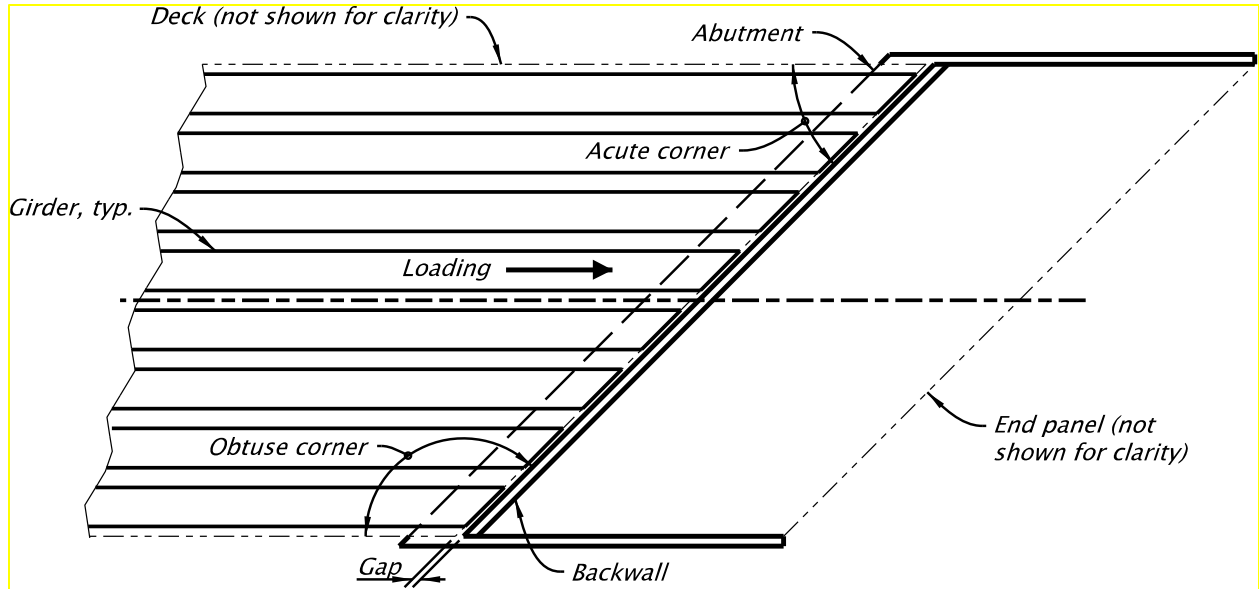

Figure 1.10.4.2-2(a)

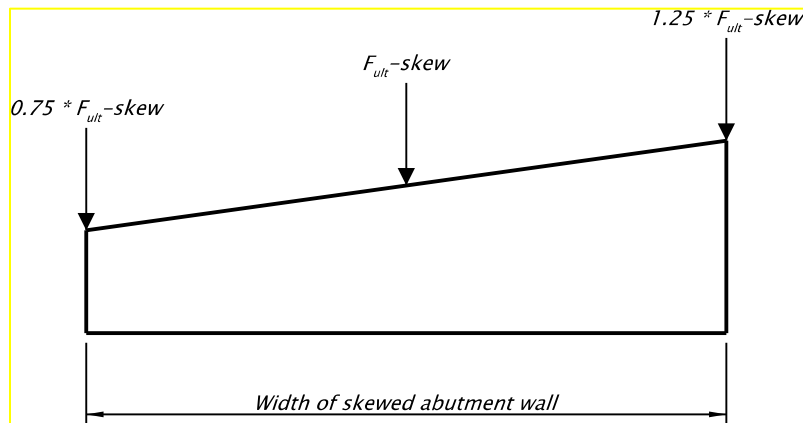

Figure 1.10.4.2-2(b)

- (3) **Spread Footings:** - Unless constructed on solid bedrock, use translational and rotational springs in both the longitudinal and transverse directions. In general, footings keyed into a rock mass that has an elastic (Young's) modulus typically greater than 14,000 ksf (Unconfined Compressive Strength = 1000 psi) can be considered "fixed" against both rotation and translation. Consult with the Geotechnical Designer to determine the compressibility of very soft or highly fractured bedrock materials.

Translational and Rotational stiffnesses:

Use the equivalent circular footing formulas on the following pages with information from Table A, to develop translational and rotational spring constants. Consult with the Geotechnical Designer for the appropriate soil values to use in *Table A*.

Bridge Design Manual – June 2020
Oregon Department of Transportation
Section 1 – Design Standards

	SPT "Nc"*	E (ksf)	Poisson's Ratio (ν)	G (ksf)
Granular				
V. Loose	4	300	.35	110
Loose	10	1000	.35	370
Medium	30	2000	.35	750
Dense	50	3000	.35	1100
Cohesive				
Soft	4	400	.50	150
Stiff	8	1000	.50	350
Very Stiff	16	1500	.50	500
Hard	32	2000	.50	650

TABLE A

* "Nc" is the average of Nc values over a depth of 2B below the footing, (B = footing width).

Stiffness Calculations for Spread Footings:

Spring constants for rectangular footings are obtained by modifying the solution for a circular footing bonded to the surface of an elastic half-space. The formula is as follows:

$$k = \alpha\beta K_0$$

where:

k = initial stiffness (spring constant)

α = foundation shape correction factor; (from graph)

β = embedment factor, (from graph)

K₀ = stiffness coefficient for the equivalent circular footing (see formulas in *Table B* below)

The stiffness term, K₀, is calculated using the equations in *Table B* below:

Displacement Degree-of-Freedom	K ₀
Vertical translation	4GR/(1-ν)
Horizontal translation	8GR/(2-ν)
Torsional rotation	16GR ³ /3
Rocking rotation	8GR ³ /(3(1-ν))

TABLE B: Stiffness coefficient, K₀, for a circular footing at the ground surface

Note:

G = Shear Modulus (low strain range)

ν = Poisson's ratio for elastic half-space material

R = Equivalent footing radius as determined from the following equations:

EQUIVALENT RADII, R , FOR RECTANGULAR FOOTING SPRING CONSTANTS:

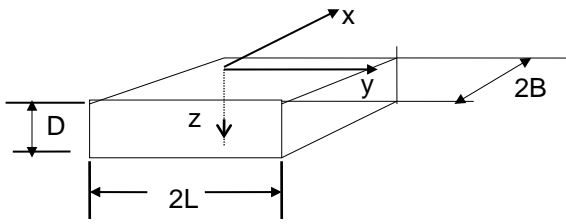

RECTANGULAR FOOTING

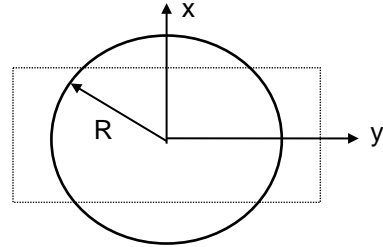

EQUIVALENT CIRCULAR FOOTING

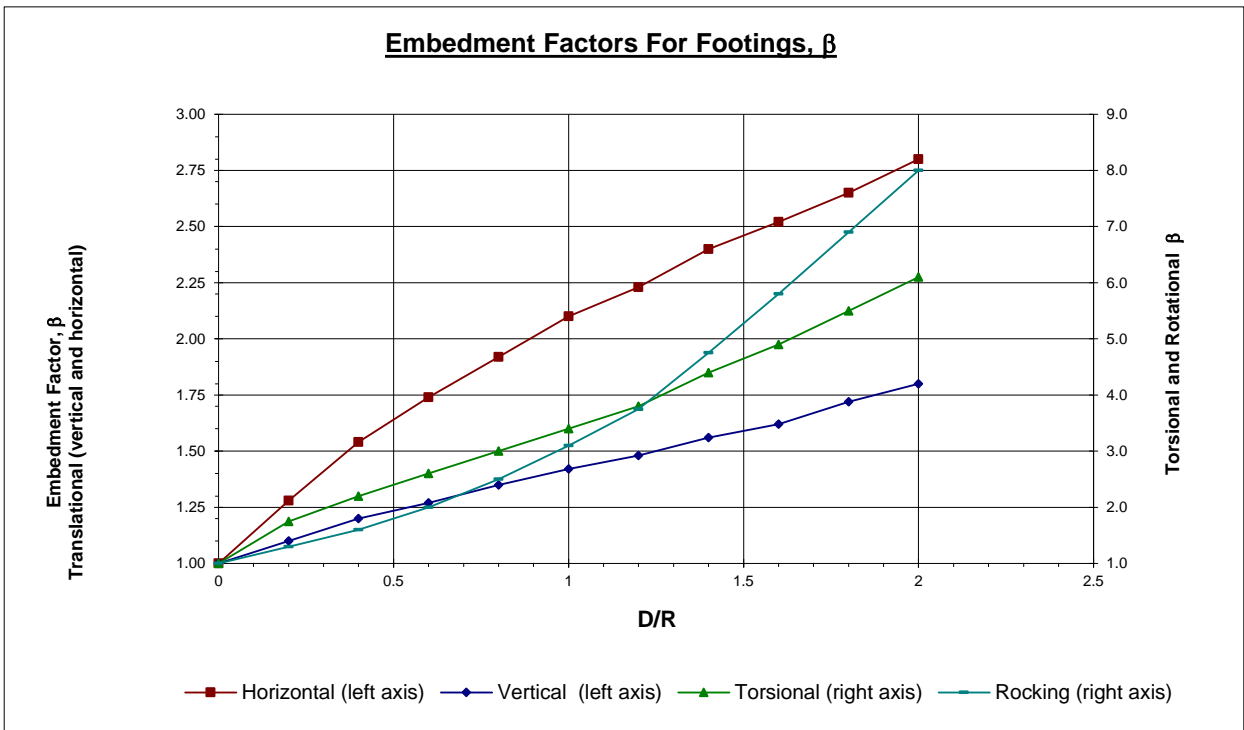
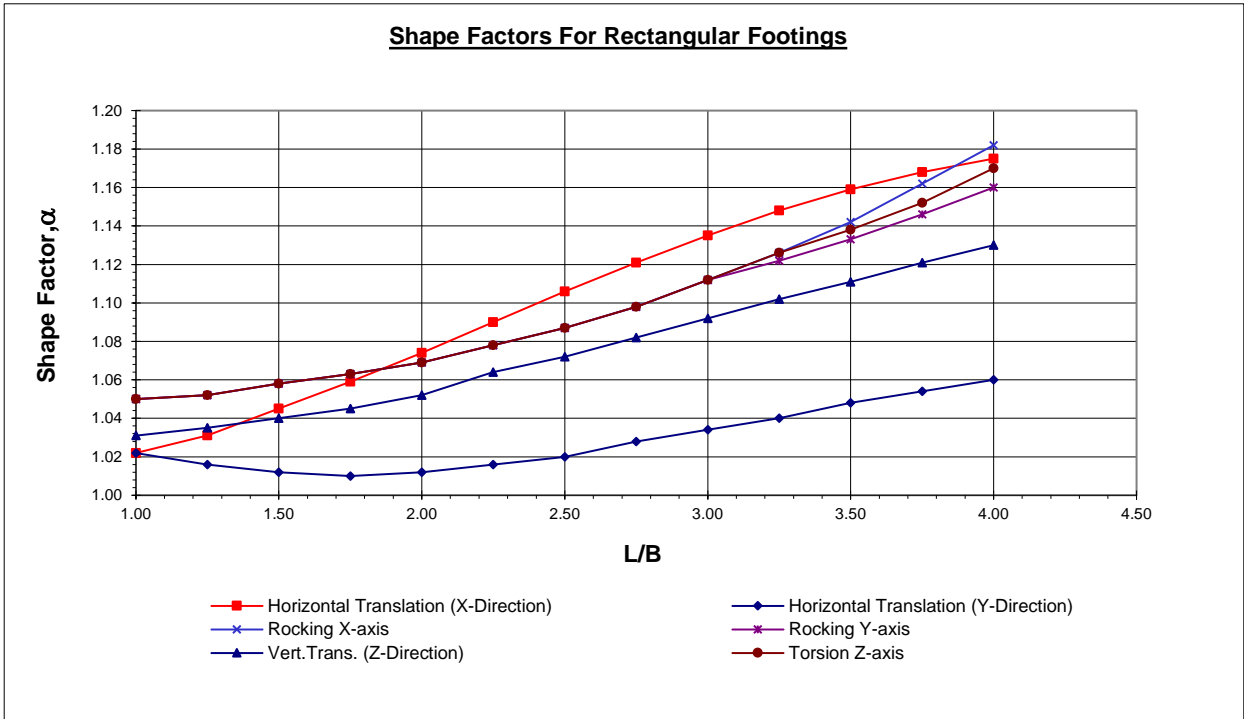

EQUIVALENT RADIUS:

TRANSLATIONAL:
$$R = \sqrt{\frac{4BL}{\pi}}$$

ROTATIONAL:
$$R = \left[\frac{(2B)(2L)^3}{3\pi} \right]^{1/4} \quad ; \text{ for x-axis rocking}$$

$$R = \left[\frac{(2B)^3(2L)}{3\pi} \right]^{1/4} \quad ; \text{ for y-axis rocking}$$

$$R = \left[\frac{4BL(4B^2 + 4L^2)}{6\pi} \right]^{1/4} \quad ; \text{ for z-axis torsion}$$

Translational Capacities:

The use of the following values depends on the footing construction method (i.e. formed with backfill material or poured against undisturbed material). Only the passive resistance developed from the front face of the footing, combined with the shear resistance along the footing base, is considered. Column and footing side resistance is neglected. Consult with the Geotechnical Designer for recommended soil properties, groundwater levels and proper effective unit stress to use in the analysis. Scour effects should also be considered.

Use the values from *Table C* in the general formula:

$$\text{Force Capacity} = (K_p \times \text{effective unit stress} \times \text{footing face area}) + (\text{Su} \times \text{footing face area}) \\ + (\mu \times \text{support reaction}) + (\text{Su} \times \text{footing base area})$$

Use appropriate components depending upon soil type. Consult with the Geotechnical Designer for the appropriate soil values to use.

Note: Effective Unit Stress = (Buoyant Unit Weight x Depth to middle of footing)

	SPT "Nc"	STATIC CAPACITY			Total Unit Wt. (k/ft ³)
Granular		K _p	Su (ksf)	μ	
V. Loose	4	2.7	0	.34	0.090
Loose	10	3.0	0	.40	0.100
Medium	30	3.7	0	.47	0.115
Dense	50	4.6	0	.56	0.120
Cohesive					
Soft	4	-	0.5	-	N.A.
Stiff	8	-	1.0	-	N.A.
Very Stiff	16	-	2.0	-	N.A.
Hard	32	-	4.0	-	N.A.

TABLE C

Deflection required to fully activate capacities (Δ_{max}):

Granular:	
Loose	.06H
Dense	.02H
Cohesive:	
Soft	.04H
Stiff	.02H

H = Soil surface to middle of footing depth

Specific applications may require the use of less than the full capacity due to deflection restrictions.

Rotational Capacities:

The rotational capacity is typically determined by comparing the total footing pressure, including the overturning moment, to the factored bearing resistance provided in the geotechnical report, unless otherwise directed by the Geotechnical Designer. The bearing resistance of footings with overturning moments and eccentricity are determined using “effective” footing dimensions.

Translational Load-Deflection Curve:

The following equation may be used in conjunction with the translational stiffnesses and capacities for developing a translational load-deflection curve for spread footings and pile caps.

$$P = \frac{\Delta}{\frac{1}{k_{max}} + \left[R_f \times \frac{\Delta}{P_{ult}} \right]}$$

- where: P = Load at deflection Δ
- P_{ult} = Ultimate passive force (neglect base shear for pile caps)
- k_{max} = Initial stiffness
- R_f = Ratio between the actual and the theoretical ultimate force. R_f can be determined by substituting Δ_{max} from the previous section for Δ and P_{ult} for P in the above equation and solving for R_f .
- Δ = Translational deflection, inches

An example of the use of this equation is given below. This graph represents the form of the equation only.

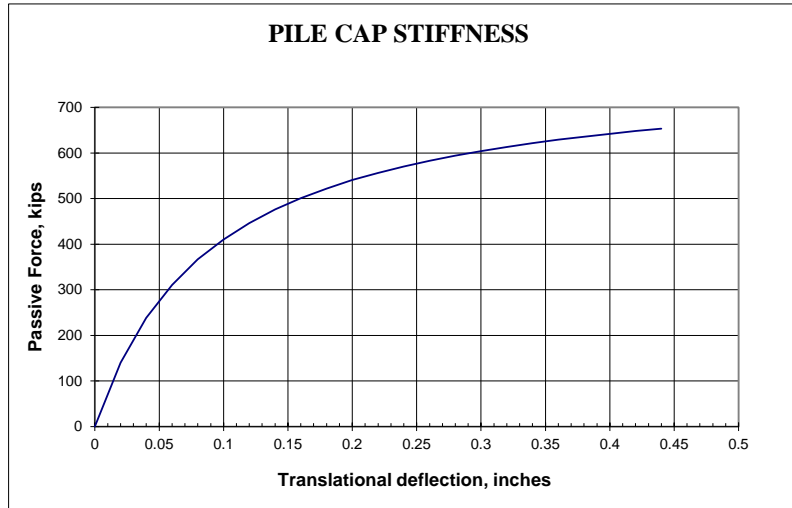

Rotational Load-Deflection Curve: Use the initial stiffness up to the capacity limit. The curve form is:

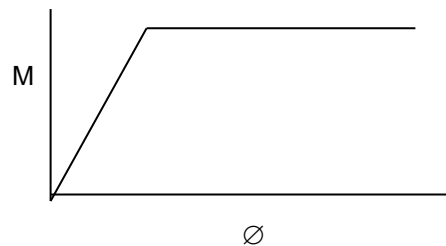

(3) Pile Supported Footings

Use translational and rotational springs for pile supported footings in both the longitudinal and transverse directions. This approach is recommended in cases where seismic loading is the controlling factor in the structural frame analysis. Springs may also be used to model pile supported footings in non-seismic conditions at the designer's discretion. Nominal resistances may be used for both non-seismic and seismic design conditions unless otherwise recommended by the Geotechnical Designer.

In cases where seismic loading is not the maximum group loading for the structure, the stiffnesses and nominal lateral resistances given in the following tables are acceptable for most design cases, provided the site conditions generally satisfy the assumptions made in developing these values. In general, for soils with "Nc" values less than 4, the pile translational stiffness should be evaluated using a soil response program such as LPILE programs and the Geotechnical Designer should be consulted for further guidance.

The use of battered piles is generally discouraged due to the greatly increased stiffness contribution from the battered piles. This in turn can result in excessive battered forces and induce undesired or unrealistic uplift forces in adjacent piles. In lieu of battered piles, it is recommended to use vertical piles throughout the footing.

Refer to the seismic design example problem for further clarification.

Translational Stiffnesses:

Normally the translational stiffness should include the lateral pile stiffnesses (total pile group stiffness) plus the passive soil stiffness on one side of the footing. Typically, a single lateral pile-head stiffness is estimated from either the pile-top, load-deflection curve generated by LPILE soil response program output or from pile stiffness values given in the following tables. This single pile-head stiffness is then multiplied by the number of piles in the group and the resulting group stiffness value is then multiplied by a group reduction factor depending on pile spacing. Instead of using a group reduction factor, pile group effects may also be accounted for using p-y curve multipliers as described under “Pile Group Reduction Factors and p-y Multipliers”.

Pile cap, or footing, stiffnesses should be developed using the methods described under “Spread Footings”, except the soil stiffness contribution along the base of the pile cap should be neglected. This is accomplished by calculating the stiffness of the pile cap (footing) at the ground surface (D = 0) and subtracting this value from the stiffness calculated for the embedded pile cap footing. The resulting stiffness curve is then combined with the pile group stiffness curve as described in “Translational Load-Deflection Curve”.

Seismic Controlled Loading Condition – Extreme Event Limit State

The pile-head translational stiffness curve is generated using a soil response program such as LPILE using soil input parameters supplied by the Geotechnical Designer. Pile head boundary conditions (fixed, free or fixed-translational) must be assigned by the designer. Refer to the LPILE computer program manuals. This method is shown in *Figure 1.10.4.2-(3)*.

Non-seismic Loading Conditions

For non-seismic loading conditions the following pile stiffnesses may be used provided the site conditions generally satisfy the assumptions given below.

Pile Translational Stiffnesses (k/in):

Axis - W=Weak S=Strong	SPT “Nc” *	HP 10x42		HP 12x53		HP 12x74		HP 14x89		HP 14x117	
		W	S	W	S	W	S	W	S	W	S
Granular											
V. Loose	4	5	8	6	10	7	11	9	13	10	14
Loose	10	12	14	12	18	14	20	16	24	18	24
Medium	30	16	20	18	27	20	30	25	38	28	41
Dense	50	25	34	29	44	31	46	40	61	44	64
Cohesive											
Soft	4	2	2	2	3	2	3	3	4	3	4
Stiff	8	4	6	5	7	6	8	7	9	7	9
Very Stiff	16	8	10	9	12	10	13	12	15	12	16
Hard	32	14	19	17	22	18	24	21	27	23	30

Bridge Design Manual – June 2020
Oregon Department of Transportation
Section 1 – Design Standards

Pipe Piles	SPT "Nc"*	12x 0.25	12x 0.38	16x 0.38	16x 0.50	24x 0.38	24x 0.50
Granular							
V. Loose	4	7	8	11	12	20	22
Loose	10	14	15	20	21	33	37
Medium	30	20	23	29	34	48	57
Dense	50	32	37	46	54	81	87
Cohesive							
Soft	4	2	3	3	3	4	4
Stiff	8	6	7	8	9	11	12
Very Stiff	16	10	11	13	14	18	18
Hard	32	18	20	24	26	34	36

Prestressed Piles	SPT "Nc"*	12" prest.	14" prest.	16" prest.
Granular				
V. Loose	4	8	8	11
Loose	10	12	14	19
Medium	30	22	24	28
Dense	50	34	38	45
Cohesive				
Soft	4	3	3	3
Stiff	8	7	7	8
Very Stiff	16	12	12	14
Hard	32	22	23	26

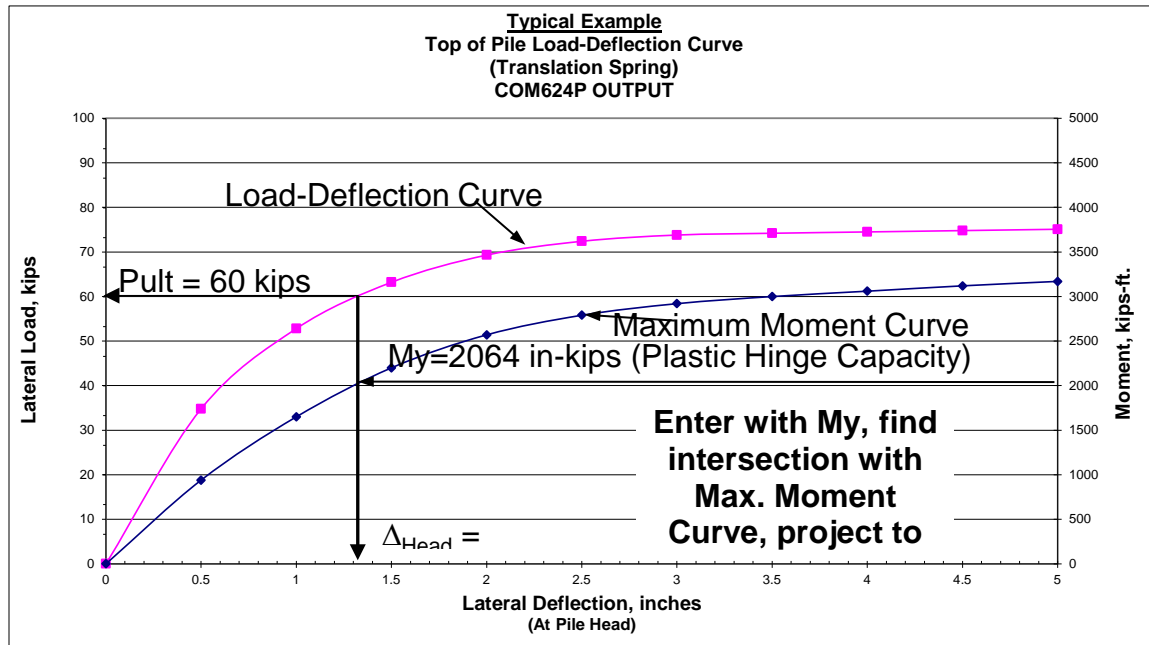

Figure 1.10.4.2-(3)

Bridge Design Manual – June 2020
Oregon Department of Transportation
Section 1 – Design Standards

Translational Capacities:

The base shear resistance of pile supported footings, or caps, is typically not included in calculating the nominal passive resistance. The same equation used for determining the nominal translational capacity of footings should be used for pile caps, neglecting all base shear resistance. The nominal passive resistance of pile caps can be used for both seismic and non-seismic design conditions.

For non-seismic loading conditions the following nominal resistances in the following table may be used provided the site conditions generally satisfy the assumptions given below the table.

Nominal Pile Translational Resistances (kips):

H-piles W=Weak S=Strong	SPT "Nc"*	HP 10x42		HP 12x53		HP 12x74		HP 14x89		HP 14x117	
		W	S	W	S	W	S	W	S	W	S
Granular											
V. Loose	4	12	21	14	25	25	43	29	50	41	69
Loose	10	13	23	16	27	28	48	33	55	46	82
Medium	30	16	26	17	31	31	53	37	62	51	86
Dense	50	17	29	20	34	34	59	41	69	57	93
Cohesive											
Soft	4	16	25	17	28	29	47	34	53	45	69
Stiff	8	20	34	22	37	38	63	43	70	59	94
Very Stiff	16	24	43	25	47	49	83	55	90	76	122
Hard	32	30	54	29	58	58	104	63	113	92	155

Pipe Piles	SPT "Nc"*	12x 0.25	12x 0.38	16x 0.38	16x 0.50	24x 0.38	24x 0.50
Granular							
V. Loose	4	22	29	43	52	85	103
Loose	10	25	32	48	57	95	113
Medium	30	29	37	54	65	107	130
Dense	50	31	41	60	71	118	143
Cohesive							
Soft	4	26	34	46	55	82	98
Stiff	8	34	44	60	72	104	126
Very Stiff	16	42	56	74	91	130	158
Hard	32	50	69	91	110	151	187

Prestressed Piles	SPT "Nc"*	12" Prest.	14" prest.	16" prest.
Granular				
V. Loose	4	12	16	23
Loose	10	15	18	25
Medium	30	18	20	29
Dense	50	20	23	31
Cohesive				
Soft	4	18	19	25
Stiff	8	22	23	31
Very Stiff	16	27	27	36
Hard	32	29	29	43

* The "Nc" values to use are the averaged "Nc" values over a depth of 8 to 10 pile diameters (8D to 10D).

The above translational stiffnesses and allowable capacities are based on the Broms' method and the following assumptions:

- Free head condition, no applied moment
- Pile top at the ground surface
- Level ground surface
- One, uniform soil layer with uniform soil properties
- No groundwater
- Static loading, no cyclic soil degradation
- Constant pile properties and dimensions
- Stiffnesses are for first 1/2 inch deflection (initial secant modulus)
- Values are for “long” pile conditions and minimum pile embedment depths are required. If pile lengths are less than 75 percent of the assumed penetration lengths below, a separate Broms' or LPILE analysis is required.

	“Nc”	<u>Assumed Length (ft)</u>
Granular	4	55
	10	50
	30	40
	50	35
Cohesive	4	55
	8	50
	16	40
	32	35

The Geotechnical Designer should be consulted for piles installed in conditions outside of the above stated assumptions and/or a LPILE analysis should be performed.

For seismic design conditions, the maximum moment capacity of the pile (M_y) must be calculated separately and compared to the LPILE output to determine the nominal lateral resistance and associated deflection. An example is shown in *Figure 1.10.4.2-(3)*.

Translational Load -Deflection Curve:

Translational Load Non-seismic - Deflection estimates for piles designed under non-seismic conditions should be determined using the initial pile stiffness values given in the above tables extended up to the nominal pile resistance (bilinear curve). This curve, representing the pile group, is then added to the load-deflection curve developed for the pile cap. A LPILE analysis may also be used as described below if so desired.

Translational Load Seismic - Deflection estimates for seismic design conditions are determined from the composite load deflection curves developed by combining the pile group stiffness from the LPILE analysis with the stiffness contribution from the pile cap. An example of this procedure is provided in the section on “Load-Deflection Curves, Stiffness Iteration Analysis and Capacity Checks”.

Pile Group Effects and P Multipliers:

The P multiplier approach, utilizing the LPILE program, is recommended to evaluate the response of pile groups subjected to lateral loads. The P multipliers are applied to standard p-y curves to account for pile group effects. *LRFD 10* should be referenced for the P multiplier values to be used in the analysis. The P multipliers are dependent upon the center to center spacing of piles in the group in the direction of loading expressed in multiples of pile diameter. The Geotechnical Designer should be consulted for the procedures to use in this design approach.

Rotational Stiffnesses:

Normally the rotational stiffness should only include the moment versus rotation stiffness from the pile group. The pile cap is usually considered rigid in this analysis and no additional stiffness due to soil bearing at the base of the pile cap/footing is included. Therefore, the rotational stiffness of pile caps is simply a function of pile axial compression and the pile group layout. See the example problem in the Bridge Example Designs notebook for more details. Static formulas for pile compression are typically used. The computer program APILE may also be used for a more detailed analysis of the predicted load-deflection behavior of a single, axially loaded pile. This program takes into account unusual soil conditions and the nonlinear aspects of pile-soil interaction. The Geotechnical Designer should be consulted for axial pile stiffnesses using the APILE program.

The following formulas for axial pile stiffness may be used in developing rotational stiffnesses for pile supported footings. For friction piles, the APILE program may also be utilized to better model axial stiffness when axial loads are greater than about half of the nominal resistance of the pile.

<p>End bearing pile:</p> $K_v = \frac{AE}{L}$	<p>Friction piles:</p> $K_v = \frac{2AE}{L}$
--	---

with: K_v = Axial Pile Stiffness (kN/mm)
 A = Area of pile normal to load
 L = Length of pile
 E = Young's Modulus of Pile Material

Compute the rotation stiffness (M vs. \emptyset) for a pile group as follows:

Assume a pile head deflection for the pile farthest from the pile group centroid.

Using the appropriate relation from above, determine the pile force accompanying this assumed pile head deflection. Prorate the other pile forces by their location relative to the group centroid. Piles on one side of the centroid will have positive forces and piles on the other side will have negative forces (uplift).

Determine the pile group moment by summing the product of the pile force and the pile-to-group centroid distance for all piles. This is the moment (M) required to rotate the footing through an angle of \emptyset . Determine the angle \emptyset as the arctan of the assumed extreme pile head deflection divided by the pile-to-centroid distance.

The relation of M to \emptyset is the initial rotation stiffness.

Rotational Resistances:

For pile supported footings, compare computed pile loads to nominal axial pile resistances for seismic cases and to factored axial pile resistances for non-seismic cases, unless otherwise recommended by the Geotechnical designer.

Rotational Load-Deflection Curve:

Use the initial stiffness up to the resistance limit. The curve form is:

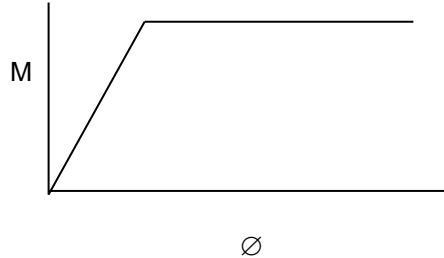

(4) Load-Deflection Curves, Stiffness Iteration Analysis and Capacity Checks:

Using the previous information one develops a composite load-deflection relationship for each applicable support spring. Next, an initial spring constant is assumed, the structure and loading analyzed and the resulting load-deflection position compared to the initial assumption. Cycling through this process may be needed to achieve reasonable closure. See the graphical explanation below.

It is also necessary to check the required resistance against the factored or nominal resistance. Resistance factors of 1.0 are typically used in the case of seismic design, however this should be verified by the Geotechnical Designer. Factored resistances are used for all other cases. For the rotational capacity, this is normally done by checking the resultant forces against the maximum (nominal), effective soil bearing resistance (footings) or nominal pile resistance.

For lateral pile resistances, the nominal resistance is either the maximum determined from the LPILE analysis (based on M_y of the pile for seismic design), or from the tables. The nominal resistance may also be a function of maximum allowable structural deflections. If the limiting resistance is exceeded when using the initial spring coefficient then modified springs are required as shown in the graphical explanation below.

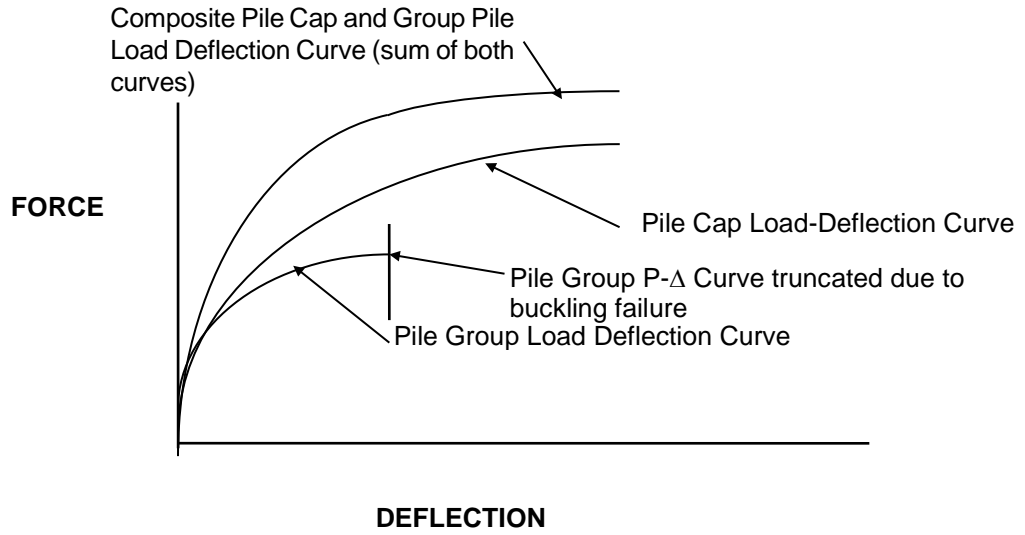

Development Composite Load - Deflection Curve

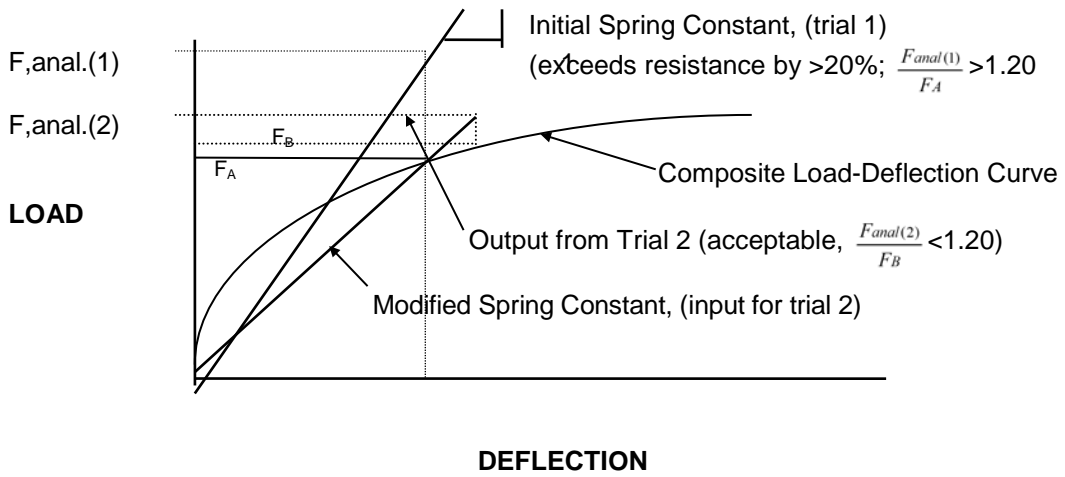

Spring Iteration Process and Resistance Checks

1.10.4.3 Drilled Shaft Modeling (Fully Coupled)

Programs Midas Civil or SAP200 and LPILE can be used in an iterative approach to model a drilled shaft supported structure. The approach is to determine the approximate force magnitudes for the controlling loading and then use these forces to develop a better representation of the superstructure/shaft/soil problem. This allows a good approximation of soil stiffness non-linearity as well as the non-linearity of the shaft-soil interaction.

The following steps would be typical for drilled shaft modeling for design and checking:

1. Develop a full Midas Civil or SAP2000 model (superstructure with substructure) using shaft fixity at two shaft diameters below the groundline. Using the model, run the controlling load case – typically seismic loading will be the controlling case and the worst effect, either longitudinal or transverse, will be used for the next steps.
2. Develop LPILE models (shaft with soil) for each bent using the full shaft from its tip to its connection to the superstructure.
3. Using the top of shaft shear and moment results from the first Midas Civil or SAP2000, load the LPILE models to develop a stiffness matrix for each shaft. This represents a condensing of the substructure/soil effect to the point of connection with the superstructure. The LPILE program can develop a stiffness matrix for you.
4. Develop a new Midas Civil or SAP2000 model using only the superstructure and supports represented by the LPILE developed substructure stiffness matrices. Run the same controlling load case.
5. Use the top of shaft shear and moment results from this latest Midas Civil or SAP2000 to again load the LPILE models to develop new substructure stiffness matrices.
6. Use the latest Midas Civil or SAP2000 model with the most recent substructure stiffness matrices and again run the same controlling load case.
7. Compare the results of this Midas Civil or SAP2000 with the previous Midas Civil or SAP2000 run for correlation. If the results do not correlate well, cycle through steps 5 and 6 to get better convergence. Results which change no more than 15% per cycle are normally sufficiently close and further cycling is not required.

1.10.5 Foundation Design

Foundation design should be performed in accordance with the most current version of the AASHTO LRFD Bridge Design Specifications. Foundation design should also follow the policies and guidelines described in the ODOT Geotechnical Design Manual, available through the ODOT Geo-Environmental Section web page.

FHWA foundation design manuals are also acceptable methods for use in foundation design. Subsurface investigations for all structures should be conducted in accordance with the AASHTO Manual On Subsurface Investigations (1988). Materials classifications should be in accordance with the ODOT Soil and Rock Classification Manual (1987).

1.10.5.1 Foundation Design Process

A flow chart showing the overall foundation design process, related to plans development, is provided in *Figure 1.10.5.1A*. It is important for the Foundation and Bridge Designers to establish and maintain good communication and exchange of information throughout the entire bridge design process. Any questions regarding foundation design issues should be brought to the attention of the Geotechnical Designer as early as possible in the design process. For most typical bridge design projects two Geotechnical Reports are provided, the TS&L Foundation Design Memo and the Geotechnical Report. A description of the phases follows.

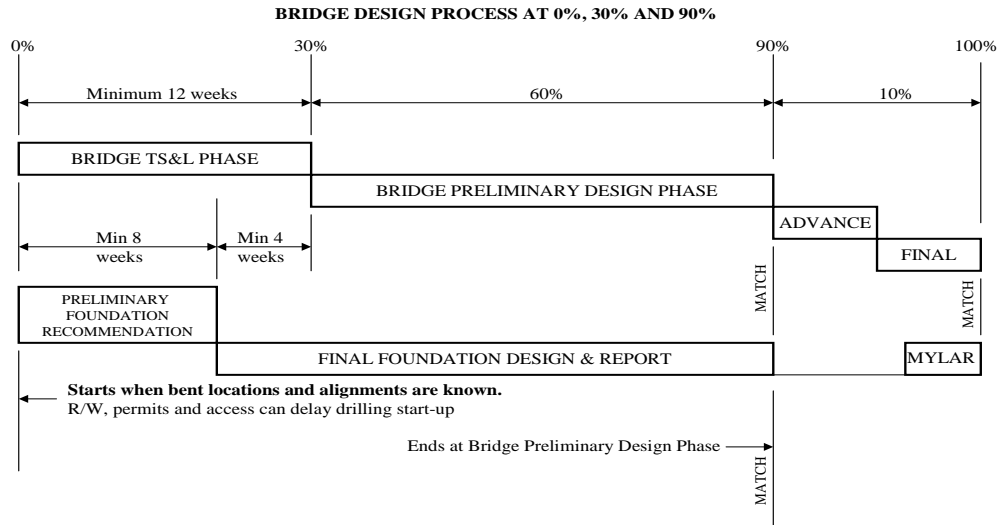

Figure 1.10.5.1A

(1) TS&L Foundation Design Memo

The purpose of this memo is to provide sufficient data for developing TS&L plans and cost estimates and for permitting purposes. The memo is generally provided before the subsurface investigation is completed. It provides a brief description of the proposed project, the anticipated subsurface conditions (based on existing geologic knowledge of the site and/or as-constructed information) and presents preliminary foundation design recommendations such as foundation types and preliminary resistances. The potential for liquefaction and associated effects are also briefly discussed. The memo is to be provided no later than two-thirds of the way through the TS&L design process.

(2) Geotechnical Report

This report is to be provided by the end of the Preliminary Bridge Design phase, which is usually 90 percent design. It provides the final foundation design recommendations for the structure and a Geotechnical Data Sheet for each structure. In order to conduct a proper foundation investigation and complete this report the Geotechnical Designer will need the following information:

- Bent locations and layout
- Proposed roadway grade (fill heights)
- Anticipated foundation loads
- Foundation size/diameter and depth required to meet structural needs
- Allowable structure settlements (total and differential)
- Proposed retaining wall locations
- Estimated scour depths (from Hydraulics Report)
- Construction or Environmental constraints that could affect the type of foundation selected

The report will contain the all geotechnical data on the site including final boring logs, Geotechnical Data Sheets, laboratory test results, foundation soil design parameters, recommended foundation types, sizes and resistances, and other recommendations. Construction recommendations are included along with project specific specifications, which are to be included in the contract Special Provisions. Seismic foundation design recommendations are provided including site characterization and soil coefficients, estimated ground acceleration and any liquefaction mitigation measures considered necessary (See *BDM 1.17*).

The Geotechnical Designer should review the final Plans and Special Provisions for the structure to make sure they are consistent with the design recommendations provided in the Geotechnical Report. Any discrepancies should be resolved and Addendums to the report issued if necessary. A copy of the Geotechnical Report should be included in the project file and is made available to contractors through the Project Manager's Office when the project is advertised for bid.

1.10.5.2 Bridge Foundation Records

"As-constructed" records on existing bridge foundations may be found in the Salem Bridge Engineering Office from the following sources:

- Pile Record Books
- "As-constructed" Bridge Plans (available through ODOT intranet)
- Microfilm Construction Records
- Bridge Maintenance Files

1.10.5.3 Spread Footing Foundation Design

Spread footings are considered early on in the design process as a possible economical foundation option if the foundation conditions are suitable. The design of spread footings is usually an interactive process between the Geotechnical and Structural Designers. The bottom of spread footings should be at least 6 feet below the bottom of the streambed unless non-erodable bedrock is present. The bottom of spread footings should also be below the estimated depth of scour for the 500 year flood event. The top of the footing should be below the depth of scour estimated for the 100 year event. Spread footings are not to be constructed on soils that may liquefy under earthquake loading. If spread footings are recommended the Geotechnical Designer will provide the following design recommendations in the Geotechnical Report:

(1) Footing Elevations

The elevations of the proposed footings will be provided along with a clear description of the foundation materials the footing is to be constructed on.

(2) Nominal and Factored Bearing Resistances

The nominal and factored bearing resistances will be provided for various effective footing widths likely to be used. Resistance factors for all applicable load combinations should be consistent with the most recent version of AASHTO LRFD Bridge Design Specifications.

Bearing resistances corresponding to 1 inch of settlement (Service Limit State) should also typically be provided unless other settlement limits are established by the structural designer. The Structural Designer should communicate all footing settlement limits to the Geotechnical Designer. For soil conditions, the bearing resistances provided assume the footing pressures are uniform loads acting over effective footing dimensions B' and L' (i.e. effective footing width and length $((B \text{ or } L) - 2e)$) as determined by the Meyerhof method. For footings on rock, the resistances provided assume triangular or trapezoidal stress distribution and maximum toe bearing conditions.

Minimum footing setback on slopes and embedment depths will be provided.

(3) Sliding Stability and Eccentricity

The following soil parameters will be provided for calculating frictional sliding resistance and active and passive earth pressures.

- Soil Unit Weight, γ (soil above footing base)
- Soil Friction Angle, ϕ (soil above footing base)
- Active Earth Pressure Coefficient, K_a
- Passive Earth Pressure Coefficient, K_p
- Coefficient of Sliding, $\tan \delta$

(4) Overall Stability

The Geotechnical Designer will evaluate overall stability using the maximum footing load which can be applied to the design slope while maintaining resistance factor of 0.65 as outlined in *LRFD 11.6.2.3*.

1.10.5.4 Pile Foundations

If spread footings are unsuitable or uneconomical for foundation support, driven piles should be considered. Consult with the geotechnical designer to determine the most appropriate pile type, size and bearing resistance to support the desired pile loads. Typical pile types, sizes and factored resistances used on ODOT projects are listed below. The factored resistances provided are based on the factored structural resistance of the pile and are for use in preliminary design. The Geotechnical Designer should verify these resistances for final design and provide the nominal resistances required to achieve the factored resistance.

Steel and Timber Piling

TYPE	TYPICAL PILE BEARING RESISTANCE (tons)
TIMBER PILES	42
Treated (untreated) timber	
STEEL PILES	
HP 10x42	85
HP 10x57	110
HP 12x53	110
HP 12x74	160
HP 14x73	150
HP 14x89	180
HP 14x117	240
PIPE PILES	
PP 12.75 x 0.375	110
PP 14.0 x 0.438	130
PP 16.0 x 0.500	170
PP 20.0 x 0.500	215
PP 24.0 x 0.500	265

When steel piles are installed under environmental conditions meeting corrosion criteria as described in *BDM 1.26.5*, specify a method of corrosion protection for the steel piles or determine required cross-section of the steel piles throughout the minimum design life. Corrosion rates for sacrificial thickness are specified in *BDM 1.26.5*.

Precast Prestressed Piling

See *Drawing 43308*.

The bending resistance of precast prestressed concrete piles is much less than steel piles of comparable bearing resistance. If seismic loads and lateral resistance are a concern, precast prestressed piles should normally not be used. If they are desired, either for aesthetic or corrosion considerations, a special pile design for each project will be necessary. If this is the case, notify the Geotechnical Designer as soon as possible so concrete piles can be considered in the geotechnical analysis and report.

Where precast prestressed piles are used as columns, see *Design Procedures for Pretensioned Prestressed Concrete Bearing Piles and Sheet Piles* by T. Y. Lin.

Drawing 43308 permits the use of a prestress force yielding a final concrete stress of 700 to 1000 psi depending on the range of stress that best suits handling needs. For example, a short pile requires less stress than a long pile for pickup and handling so the required number of strands could be fewer.

This change could affect the capacity of the pile if it is used as an unsupported column. If a stress greater than 700 psi is needed for your design, add a note to the plans requiring the contractor to use the appropriate prestress force.

Piling Considerations

(1) Pile Resistance

Nominal pile resistances will be provided according to AASHTO LRFD design procedures. The resistance factor will be provided according to the construction quality control method recommended in the Geotechnical Report (i.e. dynamic formula, wave equation, Pile Driving Analyzer, etc.). The geotechnical and bridge designers should confer to make sure the pile types and sizes selected take full advantage of the available geotechnical and structural resistances if possible.

(2) Downdrag Loads

Pile downdrag loads, due to soil settlement other than that caused by dynamic (seismic) loading, are added to the factored vertical dead loads on the foundation in the Strength Limit state. Load Factors for downdrag loads will be recommended by the Geotechnical Designer. Transient loads should not be included with the downdrag loads in either the strength or service limit state calculations. Downdrag loads resulting from liquefaction or dynamic (earthquake) induced soil settlement should be considered in the Extreme Event limit state pile design. Downdrag loads resulting from soil liquefaction are different than those caused from static loading and they should not be combined in the Extreme Limit state analysis.

At sites where downdrag conditions exist, the pile must overcome the frictional resistance in the downdrag zone during installation. This resistance should not be included in the calculation of available factored resistance since after installation it reverses over time becoming the static downdrag load.

(3) Uplift Capacity

In general, the uplift resistance is the same as the pile friction (side) resistance. Resistance factors and factored uplift resistances will be provided in the Geotechnical Report. Friction resistance in downdrag zones should be considered available for uplift resistance. The Geotechnical Designer should be consulted regarding the ability of the piles to resist uplift forces under various loading conditions (static or dynamic).

(4) Minimum Pile Tip Elevation

Minimum pile tip elevations (embedment depths) are typically required to meet one or more of the following design requirements:

- a) Lateral Load
- b) Scour
- c) Liquefaction
- d) Uplift loads
- e) Settlement and/or Downdrag
- f) Required soil/rock bearing strata

The required pile tips elevations should be shown on the plans and labeled as “Required Minimum Pile Tip Elevations”. Large lateral loads due to seismic, or other, conditions may result in the need for additional piling, or larger piles, in order to satisfy lateral deflection criteria or other requirements. This may in turn result in individual axial pile loads being much less than the maximum factored resistances available (either geotechnical or structural). Conversely, if pile tip elevations are needed to meet scour, uplift, or other requirements, the piles may need to be driven through very dense materials to nominal resistances much higher than needed for supporting just the axial loads. Close communication is needed between the

Geotechnical and Bridge Designers to determine the most economical foundation design under these conditions.

(5) Pile Group Settlement

Pile group settlement should be compared to the maximum allowable settlement and pile depths or layout adjusted if necessary to reduce the estimated settlement to acceptable levels.

(6) Pile Group Effects

For pile group lateral load analysis use the p-y multiplier methods described in *LRFD* and the FHWA Manual on the “Design and Construction of Driven Pile Foundations”.

(7) Pile Spacing

Use a minimum spacing of 3 feet for piles placed underwater. Above water pile spacing should be no closer than 2.5B.

(8) Pile Tip Treatment

Where pile tip reinforcement is required, specify commercial cast steel points or shoes.

Where closed-ended pipe piles are required, specify a welded end plate and/or a welded end plate with stiffeners having the same diameter as the pipe pile. An analysis was performed for a range of pipe pile sizes which verified sufficiency and the minimum dimensions for the end plate and stiffeners. This analysis was conducted using $0.9f_y$ as the maximum load, which is the maximum stress the pile will undergo and what is allowed during pile driving. Provide dimensions for the end plate and stiffeners on plan sheets for each project. Deviation from the minimum dimensions below requires project specific shell and buckling analyses and driving stress from the Geotechnical Designer.

Table 1.10.5.4-1 provides the minimum dimensions for a welded end plate and a welded end plate with stiffeners. Use these dimensions with *Figures 1.10.5.4A-1* Welded End Plate and *Figures 1.10.5.4A-2* Welded End Plate with Stiffeners. The figures are available online in the Standard Details at the following location [Welded Plate Details](#). These details are available for project specific use.

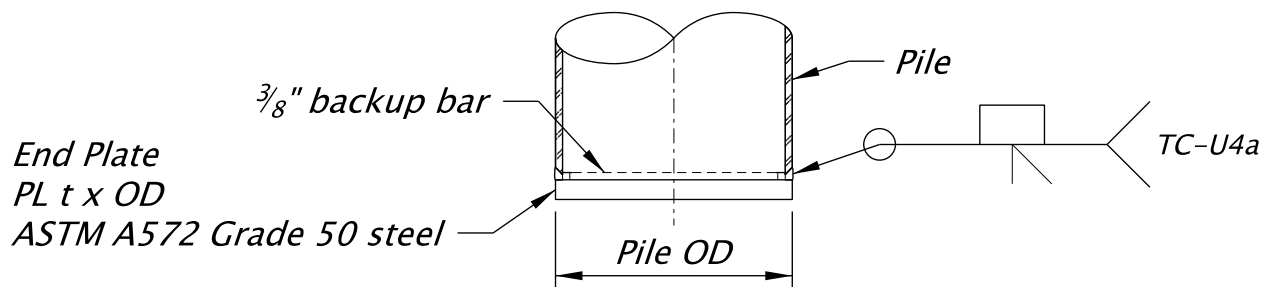

PILE END SECTION

WELDED END PLATE

See Table 1.10.5.4

Figure 1.10.5.4A-1

Bridge Design Manual – June 2020
Oregon Department of Transportation
Section 1 – Design Standards

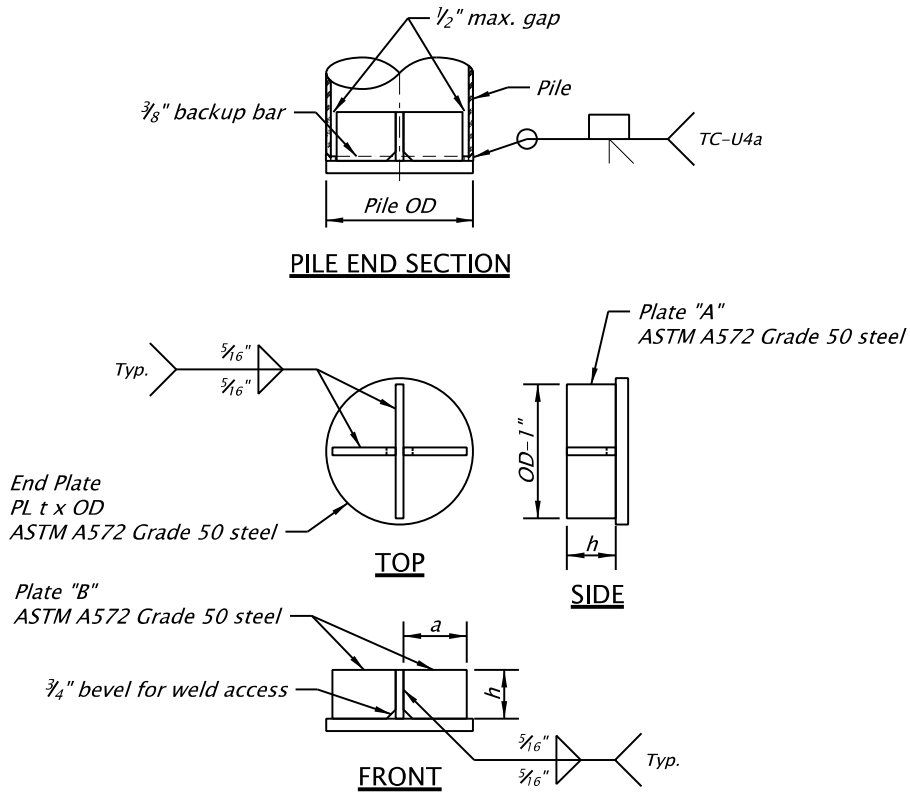

WELDED END PLATE WITH STIFFENERS

See Table 1.10.5.4

Figure 1.10.5.4A-2

Pipe Pile Size	End Plate Thickness No Stiffeners		End Plate Thickness With Stiffeners					
	Gr 2 Pipe	Gr 3 Pipe	Gr 2 Pipe			Gr 3 Pipe		
			End Plate	Stiffeners (Plates "A" & "B")	Plate "B" Length	End Plate	Stiffeners (Plates "A" & "B")	Plate "B" Length
<i>t</i>		<i>t</i>	<i>h</i> x <i>t</i>	<i>a</i>	<i>t</i>	<i>h</i> x <i>t</i>	<i>a</i>	
PP12 3/4 x 3/8	2.25	2.50	1.00	4 x 0.375	5.500	1.25	4 x 0.500	5.250
PP12 3/4 x 1/2	2.50	2.75	1.00	4 x 0.500	5.375	1.75	4 x 0.500	5.125
PP16 x 3/8	2.50	2.75	1.00	6 x 0.375	7.125	1.25	6 x 0.375	6.938
PP16 x 1/2	2.75	3.00	1.25	6 x 0.375	7.000	1.50	6 x 0.500	6.750
PP18 x 3/8	2.50	2.75	1.00	6 x 0.500	8.125	1.25	6 x 0.500	7.875
PP18 x 1/2	3.00	3.25	—	—	—	—	—	—
PP24 x 1/2	3.25	3.75	—	—	—	—	—	—

t=thickness; *h*=height; *a*=length

Table 1.10.5.4-1

(9) Pile Foundation Design Recommendations

The Geotechnical Designer will provide final foundation recommendations in the Geotechnical Report, or earlier in the design process as needed. The following recommendations will typically be provided as a minimum:

- a) Pile Resistance:** The nominal pile resistances (R_n) will be provided along with estimated pile lengths for one or more pile types. These values may be in tables or graphs of R_n versus depth may be provided. Modified R_n values will be provided as necessary to account for scour, and/or liquefaction conditions. The resistance factor will be provided along with the recommended method of construction control (i.e. dynamic formula, wave equation, etc.). Downdrag loads, if present, will be provided along with an explanation of the cause of the downdrag loads. The depth or thickness of the downdrag zone will be provided.
- b) The nominal pile uplift resistance** will be provided either as a function of depth or for a given pile length (typically associated with the minimum tip elevation). The pile uplift resistance will be provided for normal static conditions and for any reduced capacity condition such as scour or liquefaction. The resistance factor will be provided.
- c) P-Y Curves:** Foundation design parameters will be provided to develop p-y curves for lateral load analysis using either the LPILE or other soil response computer programs. Two sets of data may be required, one for static conditions and one for dynamic (liquefied soil) conditions.
- d) Required Pile Tip Elevations:** Required minimum pile tip elevations will be provided along with an explanation of their basis. These tip elevations (minimum pile embedments) should be checked to see if they need to be modified to meet other design requirements, such as lateral loading requirements. Any changes to the recommended required tip elevations should be reviewed by the Geotechnical Designer.
- e) Special Provisions:** The following foundation related items will be provided, as necessary, for Section 00520 of the project Special Provisions:
 - i. Wave Equation Input (if WEAP is specified for driving criteria)
 - ii. Recommended number of pile splices
 - iii. Pile tip treatment, tip reinforcement recommendations and specifications
 - iv. Recommendations regarding pile freeze, jetting, preboring or use of followers

Piling Details

(1) Steel Pile Footing Embedment to Develop Fixity

It may be necessary to develop lateral load resistance in piles or pile groups. To develop the required lateral load capacities, piles must be embedded in pile caps or footings adequately to develop the full moment capacity of the pile section.

If lateral load capacity is not needed, a pile embedment length of 12 inches is sufficient.

A simplified method of determining minimum pile embedment was developed as follows:

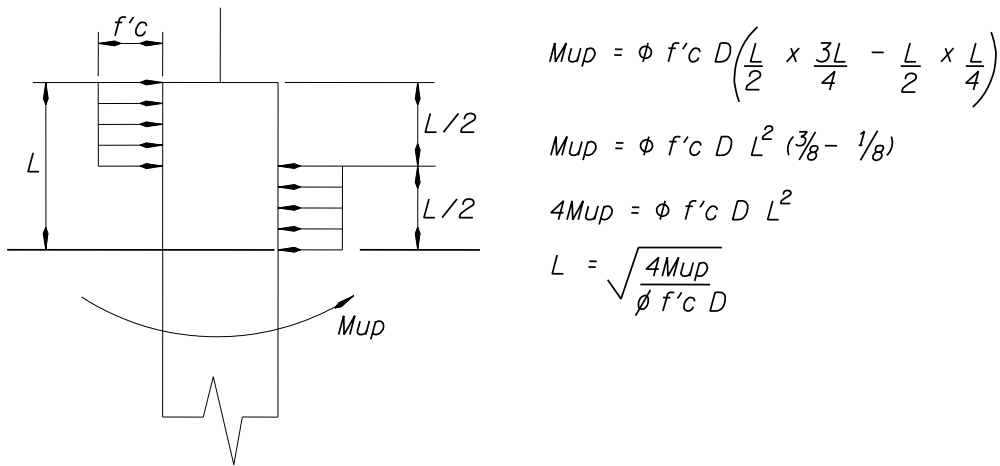

Figure 1.10.5.4B

Typical minimum embedment to develop fixity for $f'_c = 3.3$ ksi and $f_b = 36$ ksi is:

Piles:	Minimum Embedment (in)
HP 10X42 and HP 12x53	20
HP 12X74 and HP 14X89	24
HP 14X117	27
PP 10 ¾ X 0.38 and PP 12 ¾ X 0.38	15
PP 16 X 0.38 and PP 16 X 0.50	20

(2) Pipe Pile Cover Plates

Provide a welded cover plate as detailed below in *Figure 1.10.5.4C*.

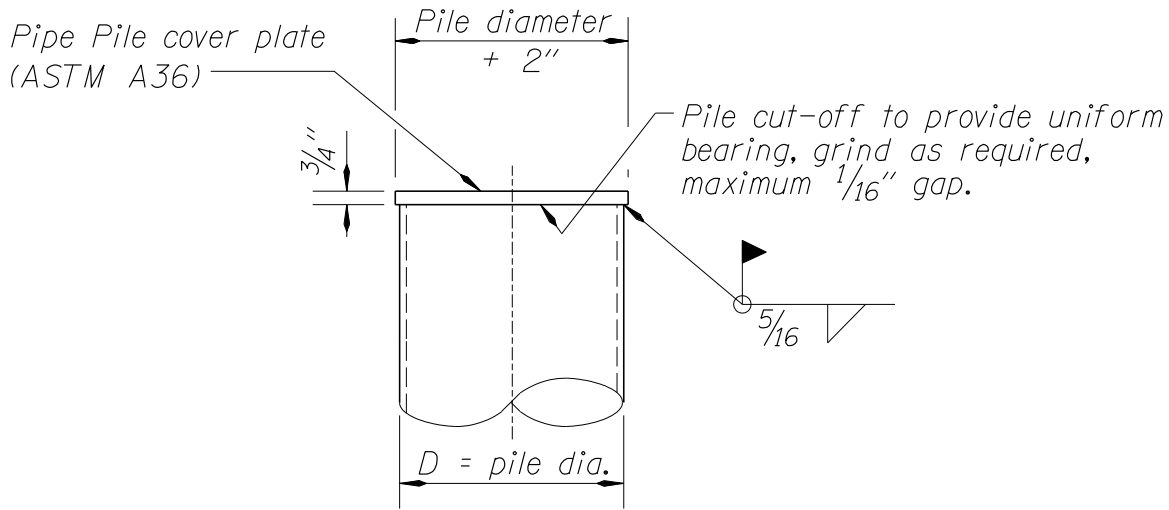

Note:
 Use for piles 18" diameter or less. For larger piles, design the plate thickness.

PIPE PILE (CLOSED ENDED)

Figure 1.10.5.4C

(3) Steel Pile Splices

If splicing of steel piles is anticipated, show one or both of the following details on the plans.

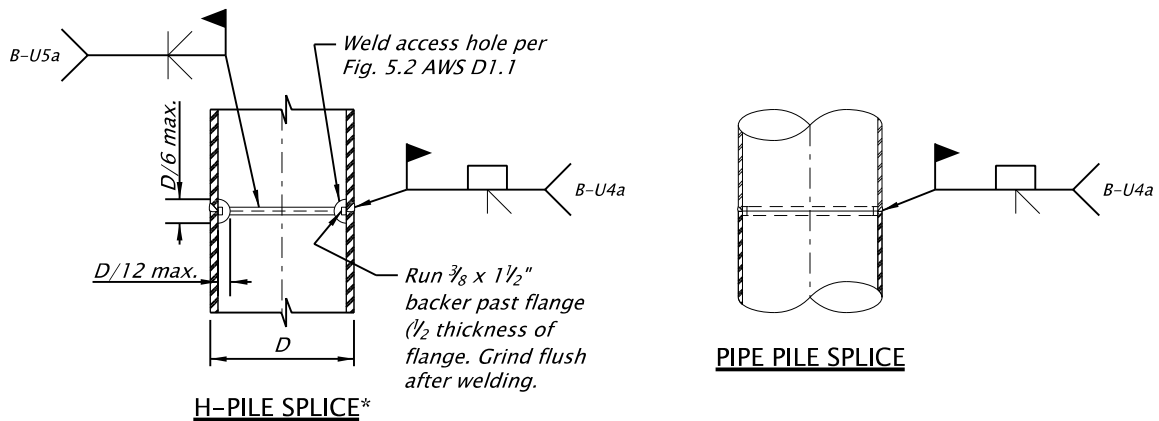
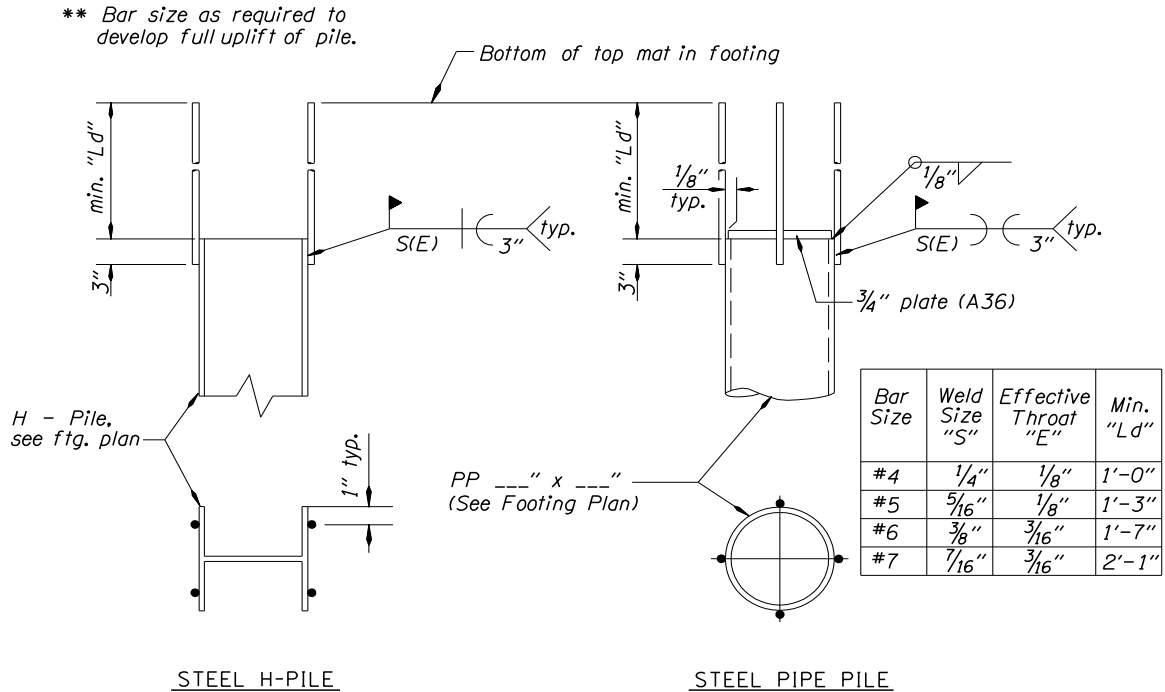

Figure 1.10.5.4D

* – Manufactured A709 Grade 36 H-pile splices may be used if located a minimum of 40 feet below the bottom of the footing and installed according to the manufacturer's recommendations.

(4) Anchor Piles

Two methods of anchoring piles are shown. Other methods such as extending the top plate and using welded studs or other shear connectors may be appropriate.



* Provide ASTM A706, except ASTM A615 Grade 60 or ASTM A496 may be used if copies of the chemical composition analysis are submitted and approved as weldable by the engineer.

ANCHOR PILE DETAILS

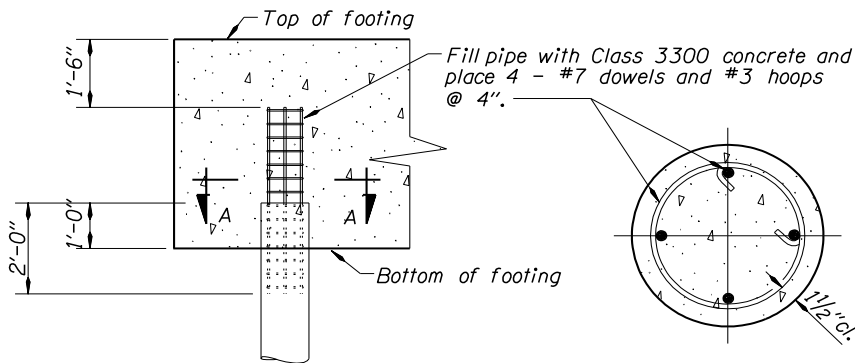

FILLED PIPE PILE ANCHOR DETAILS

Figure 1.10.5.4E

1.10.5.5 Drilled Shafts

Consider the use of drilled shafts for bridge foundations only if the Geotechnical Designer has recommended drilled shafts for the preferred foundation type and the design is economical (relative to other deep foundation designs). Consult with the Geotechnical Designer regarding site constraints, environmental issues, constructability and lateral loads before selecting drilled shafts for foundation design. The location of drilled shafts should be made early in the design process so an exploration drill hole can be located as close as possible to all drilled shaft locations for design and construction purposes.

A Drilled Shaft Task Force Group exists to aid Geotechnical and Bridge Designers in resolving constructability issues, revising specifications, and successfully implementing new technology. The Drilled Shaft Task Force Group is led by Sr Bridge Geotechnical Designer and comprised of ODOT personnel and representatives from the drilled shaft industry. Consider engaging this group early in the design process.

Drilled Shaft Design

(1) Drilled Shaft Diameters, Cover Requirements, and Horizontal Tolerances

The Geotechnical and Bridge designers should confer early in the design process to decide the most appropriate shaft diameter(s) to use for the bridge given the axial and lateral loads, column diameter, subsurface conditions, and other relevant factors.

Common shaft sizes range from 3 – 12 feet in diameter. Large shafts are difficult to construct to precise horizontal tolerances. Do not design columns the same diameter as the shaft. Consider allowable horizontal tolerances, 3 in. for 6-foot shaft or smaller and 6 in. for shaft larger than 6 ft, in shaft sizing and design. Provide additional shaft capacity to resist possible load demands in shaft that is not constructed at as-specified location.

Size drilled shaft diameters, concrete cover in drilled shafts, and column diameter using the following table:

Diameter		Concrete Cover	Horizontal Tolerance
Shaft	Max. Column		
3'-0"	2'-0"	3"	3"
3'-6"	2'-6"		
4'-0"	3'-0"		
4'-6"	3'-6"		
5'-0"	4'-0"		
5'-6"	4'-6"		
6'-0"	4'-0"	4"	6"
7'-0"	5'-0"		
8'-0"	6'-0"		
9'-0"	7'-0"		
10'-0"	8'-0"		
11'-0"	9'-0"		
12'-0"	10'-0"		

(2) Non-Contact Shaft/Column Splice

Detail shaft/column splice regions in accordance with *Figures 1.10.5.5A or 1.10.5.5B*. The splice region is $(1.7L_d + a)$ rounded up to the nearest 3 inches. Note that L_d is the modified development length per *LRFD 5.11.2.1*. The non-contact splice detail allows the column to be adjusted horizontally when the shaft is slightly out of position (but still within the horizontal tolerance for the shaft). The shaft vs. column size limits are selected to ensure this adjustment can be made without increasing the tolerance more than the standard 1 inch for the column.

Non-contact splices require a lot of equipment, often in space-limited areas. Use of permanent casing should be considered for instances when the Geotechnical Designer recommends or identifies caving conditions, restricted space, and worker safety. Permanent casing changes the resistance of the drilled shaft. Use of permanent casing must be communicated with the Geotechnical Designer so new Depth vs Resistance graphs can be developed and provided to the Bridge Designer. Permanent casing may result in longer drilled shafts.

Often, during construction temporary casing cannot be extracted. Bridge Designers should review the consequences of temporary casing becoming permanent casing. Communicate with the Geotechnical Designer these consequences so that an appropriate Drilled Shaft Installation Plan is approved during construction. Casing configurations shown on *Figures 1.10.5.5A and 1.10.5.5B* are shown as examples only.

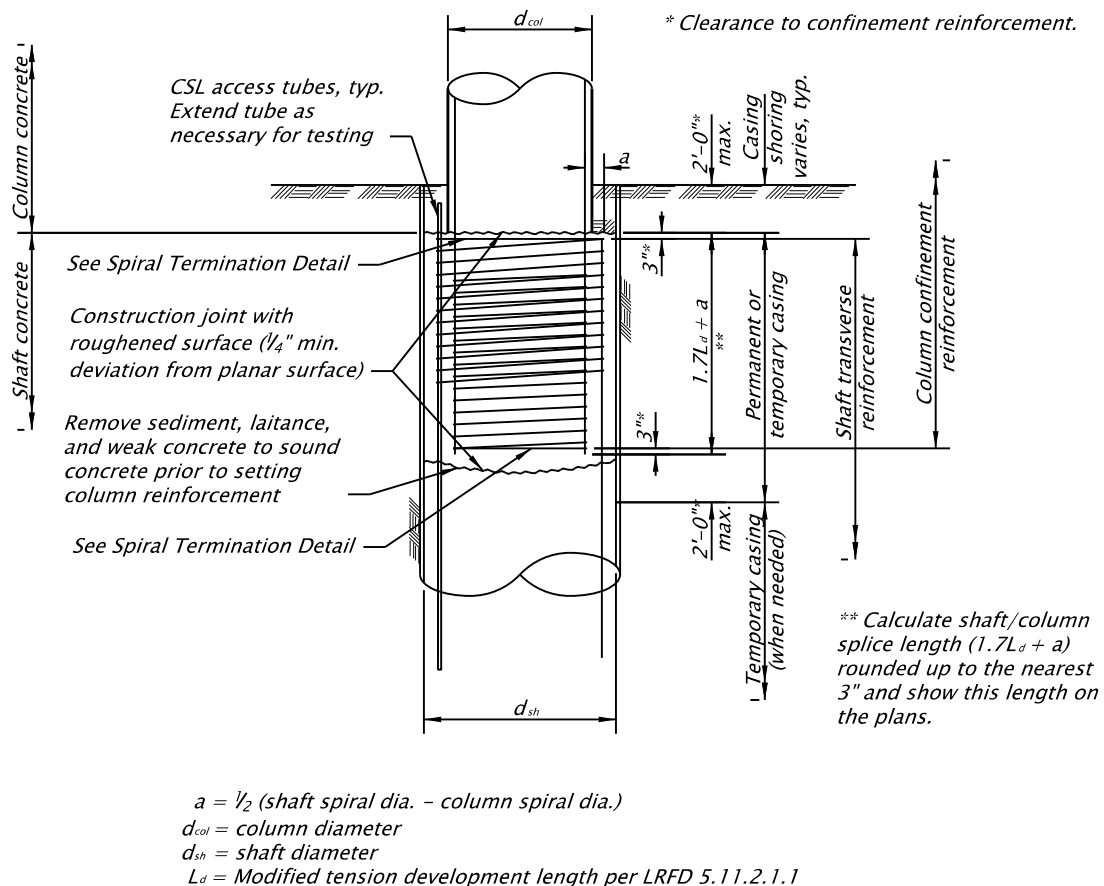

IN-GROUND SHAFT SPLICE

Figure 1.10.5.5A

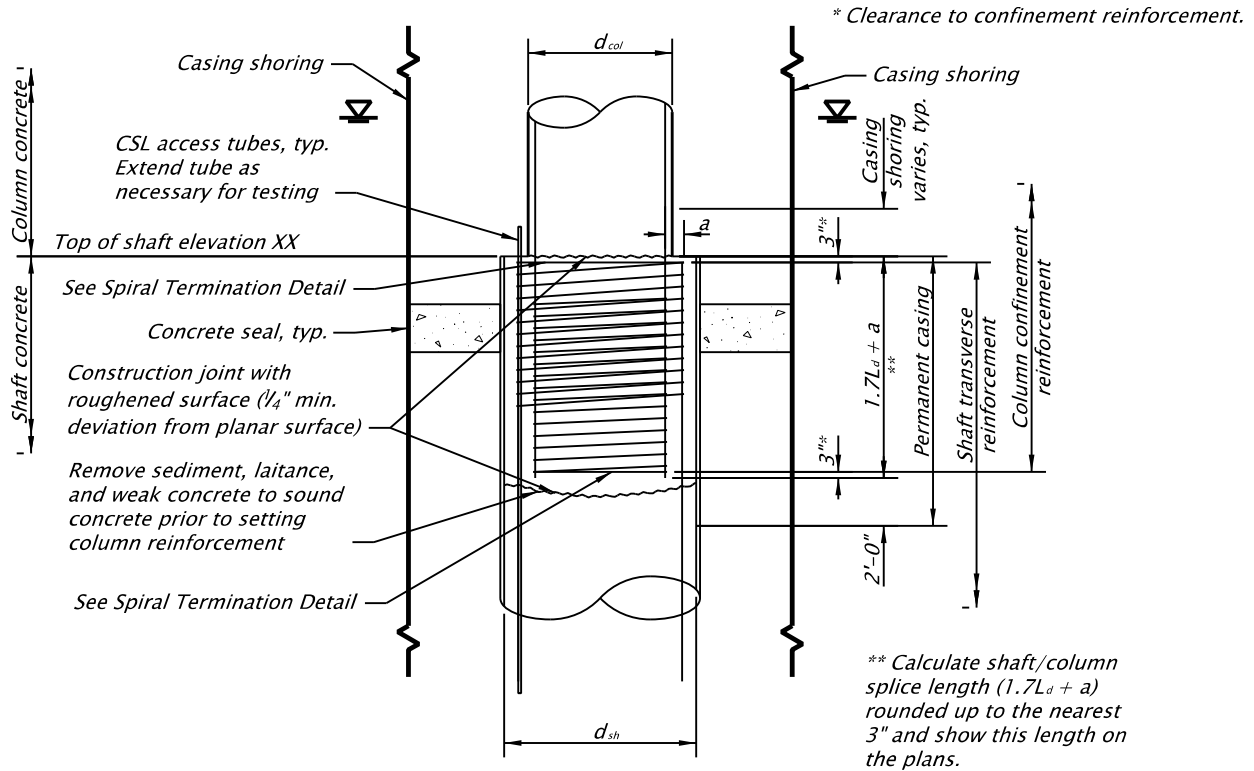

$a = \frac{1}{2}$ (shaft spiral dia. - column spiral dia.)
 d_{col} = column diameter
 d_{sh} = shaft diameter
 L_d = Modified tension development length per LRFD 5.11.2.1.1

IN-WATER SHAFT SPLICE

Figure 1.10.5B

(3) Downdrag Loads

Downdrag loads, due to soil settlement other than that caused by dynamic (seismic) loading, are added to the factored vertical loads on the foundation in the Strength Limit state. Load Factors for downdrag loads will be provided by the Geotechnical Designer. Downdrag loads resulting from liquefaction or dynamic (seismic) induced soil settlement should be considered as a permanent load and included the Extreme Event Limit State shaft design.

(4) Shaft Uplift Resistance

Shaft uplift resistance is usually the same as the side friction resistance. Friction resistance in downdrag zones should be considered available for uplift resistance.

(5) Shaft Rock Sockets

Minimum shaft embedment depths into hard rock, or rock sockets, may be required due to one or more of the following design requirements or conditions:

- Lateral Load, due to earthquake loading
- Scour
- Liquefaction
- Uplift loads
- Settlement and/or downdrag
- Required soil/rock bearing strata

For rock sockets constructed inside shafts that will require either temporary or permanent casing, consider designing the diameter of the rock socket smaller than the diameter of the cased shaft above the rock socket. This is necessary to accommodate rock auger tools which are smaller in diameter than the nominal outside diameter of the cased shaft. Reduce the shaft diameters of rock sockets by at least 6 inches in these cases.

The required rock socket embedment depths should be shown on the plans. Under this condition, shaft tip elevations should be shown as “Estimated Tip Elevations” since they are likely to change depending on the actual elevation of the top of rock or hard bearing strata encountered during construction. The Geotechnical Designer should provide an additional shaft length that accounts for the uncertainty in the top of the bearing layer and this additional length should be specified in the Special Provisions. In these cases, add the additional reinforcement required for this additional shaft length into the estimated quantities provided in *SP 00512*. Also adjust the concrete quantities to include this additional length. Extra reinforcement length can quickly and easily be cut off to provide the proper cage length once the final tip elevation is determined.

(6) Shaft Settlement

Refer to AASHTO methods to calculate the settlement of individual shafts or shaft groups. Compare this settlement to the maximum allowable settlement and modify the shaft design if necessary to reduce the estimated settlement to acceptable levels. End bearing shafts on soil will typically settle more than friction shafts in order to mobilize end bearing resistance.

(7) Shaft Group Effects

For group lateral load analysis use the p-y multiplier methods described in AASHTO and the FHWA Manual “Drilled Shafts: Construction Procedures and Design Methods”

(8) Shaft Spacing

Use a minimum spacing of 3 feet for drilled shafts.

(9) Shaft Foundation Design Recommendations

The Geotechnical Designer will provide final foundation recommendations in the Geotechnical Report, or earlier in the design process as needed. The following recommendations will typically be provided as a minimum:

- **Shaft Resistance:** The nominal shaft resistance (R_n) will be provided along with estimated shaft tip elevations for one or more shaft diameters. This may be in the form of tables or graphs of R_n versus depth may be provided. Modified R_n values will be provided as necessary to account for scour, liquefaction or downdrag conditions. The resistance factors used will be provided. Downdrag loads, if present, will be provided along with an explanation of the cause of the downdrag loads. The depth or thickness of the downdrag zone will be provided.
- **Shaft Settlement:** Estimates of shaft settlement will be provided for the range of loads expected. The Geotechnical Designer will need to know the anticipated service loads on the shaft for these calculations along with any limiting settlement criteria.
- **Shaft Uplift Resistance:** If required for design, the nominal shaft uplift resistance will be provided either as a function of depth or for a given shaft length. The uplift shaft resistance will be provided for normal static conditions and for any reduced capacity condition such as scour or liquefaction. The resistance factors used will be provided.
- **P-Y Curves:** Foundation design parameters will be provided to develop p-y curves for lateral load analysis. Two sets of data may be required, one for static conditions and one for dynamic (liquefaction) conditions if they exist.
- **Special Provisions:** The following foundation related items will be provided, as necessary, for *SP 00512*:
 - Designation as either a “friction” or “end-bearing” shaft; for cleanout purposes.
 - Permanent casing (if recommended by Geotechnical Designer or otherwise required).
 - Crosshole Sonic Log testing requirements.

(10) Post Installation Verification Testing

Crosshole Sonic Log (CSL) Testing

In general CSL tubes are installed in all drilled shafts unless otherwise recommended in the Geotechnical Report. CSL tubes may not be required in some cases where foundation conditions may be very favorable and there is redundancy in the foundation design. Consult with the Geotechnical Designer regarding the CSL testing that should be performed on the project.

The rule of thumb is one CSL tube per foot diameter of shaft, with no less than four tubes and rounding up. They are equally spaced around the shaft as shown in *Figure 1.10.5.5C*:

CSL tubes are comprised of 1-1/2 inch I.D. schedule 80 steel pipe, must be water tight and removable caps at the top for access. PVC access tubes can be used however are discouraged because debonding is more prevalent than with steel.

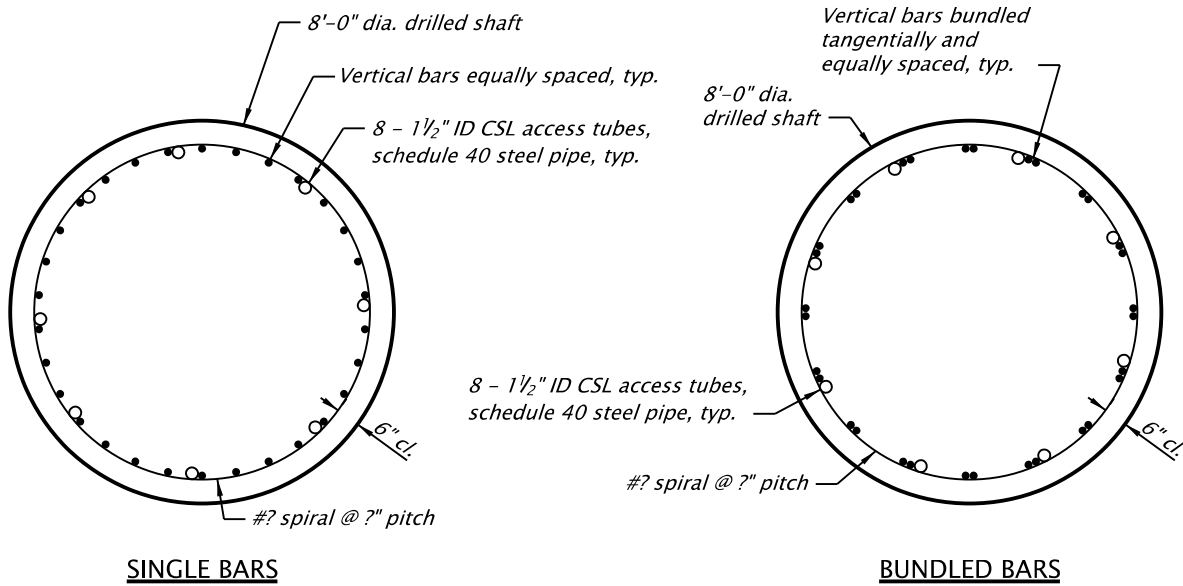

CSL TUBES IN DRILLED SHAFT

Figure 1.10.5.5C

Thermal Integrity Profile Testing

Thermal Integrity Profile (TIP) testing is a post installation integrity verification test and should be considered in addition to CSL testing in some cases. TIP should be used for drilled shafts which are non redundant, or large, or constructed underwater. Unlike CSL, TIP is able to provide rebar cage cover in addition to integrity of the drilled shaft core. TIP thermal sensors are spaced at 1 foot intervals. Quality control specifications for the use of TIP are being developed, contact Sr Bridge Geotechnical Designer at 503.986.3377 for additional guidance.

(11) Shaft Reinforcement

Determine the moment to be transferred from the column to the top of shaft according to the *AASHTO Guide Specifications for LRFD Seismic Bridge Design*. The maximum shaft moment depends on the soil-structure interaction and is generally be larger than the top of shaft moment.

Design shaft transverse reinforcement for the lesser of the plastic shear or elastic seismic shear of the column. Since the shaft diameter must exceed the column diameter, the shaft essentially remains elastic under seismic loads. If so, there is no need to satisfy the volumetric ratio and spacing requirements for transverse reinforcement in *LRFD 5.13.4.6.3*.

As well as meeting plastic shear or seismic shear demands, ensure shaft transverse reinforcement within the non-contact splice region meets the requirements in *LRFD 5.11.5.2.1*.

Detail shaft reinforcing to minimize congestion and facilitate concrete placement. Space both longitudinal and transverse reinforcement to provide 5 inches minimum and 9 inches maximum clear spacing between bars. In non-contact splice regions, transverse reinforcement spacing in the column can be as small as 3 inches in some cases. Provide 5 inches minimum clear spacing between transverse reinforcement in the shaft to minimize congestion. Transverse shaft reinforcement may include spiral bars, hoops and/or bundled pairs.

(12) Shaft Concrete

Use Class 4000 – 3/8 concrete in all drilled shafts. Concrete for drilled shafts should generally have a high slump and relatively small aggregate size in order to properly flow through the shaft reinforcement and provide the required fluid pressures against the sides of the bore hole. This is necessary to develop the desired friction resistance. Placement of concrete may be by free fall (in dry holes) or by tremie pipe (in dry or wet holes). At the present time, free fall placement of concrete in dry holes is allowed to unlimited depths. Refer to the report “Effects of Free Fall Concrete in Drilled Shafts” (ADSC Report No. TL112) for more information.

(13) Reinforcement Connections

Do not specify hooked longitudinal bars at the top of the shaft (extending into footings or caps) that will conflict with temporary casing removal. Design and detail reinforcement considering the requirements of temporary casing.

(14) Reinforcement Splicing

For shafts constructed at locations where a minimum penetration into the rock (or hard strata) is required and the elevation of the top of rock is uncertain, consider adding additional lengths of reinforcement to avoid the need for splicing. Once the final tip elevation is determined, any remaining rebar length can be cut off and removed. Splicing of reinforcement is undesirable because it usually results in delaying the concrete pour which could lead to other problems. If splicing is required, provide splicing details on the plans.

(15) Shaft Elevations

Show or list the “Top of Shaft” elevation on the plans for each drilled shaft. This elevation is the top of the drilled shaft concrete. Also show or list shaft tip elevations. If shaft tip elevations are anticipated to vary due to uncertainties in the top of the bearing strata then label these as “Estimated Tip Elevations” and show the required penetration depth into the bearing strata.

(16) Permanent Casing

The use of permanent casing may be beneficial in locations especially where the top of shafts are constructed in open water such as rivers or lakes. The use of permanent casing can simplify construction by eliminating the need for any temporary casing and forms. If permanent casing is desired it should be taken into account in the structural analysis of the bridge because it increases the stiffness and strength of the shaft and may significantly affect the overall response of a bridge subject to large lateral loads. It also affects the geotechnical side resistance. Consult with the Geotechnical Designer if permanent casing is to be used.

When permanent casing is specified remember to take OSHA requirements into account when determining casing lengths. OSHA may require casing to extend at least 2 feet above the ground surface during construction. This additional length may later be cut off and removed after the shaft is constructed.

If permanent casing is required, provide casing diameters, thicknesses and lengths in the special provisions.

(17) Shaft Diameter for Seismic Analysis

Drilled shafts are generally constructed slightly larger than the nominal diameter shown. For example, in soil conditions where casing is required, a 6-foot diameter shaft cannot be drilled inside a 6-foot diameter casing. A larger size casing diameter is required. Discuss with the Geotechnical Designer whether or not casing may be required and a larger shaft size should be checked in the structure stiffness analysis (i.e., seismic analysis).

An oversize of 6 inches is recommended for shafts up to 6 ft. diameter and 12 inches is recommended for larger diameter shafts.

(18) Drilled Shaft Preconstruction Meeting

Preconstruction meetings are held prior to beginning drilled shaft construction. This meeting should be attended by the structural designer who designed the shaft.

1.10.5.6 Seismic Foundation Recommendations

The geotechnical designer shall provide the seismic ground motion values for the Cascadia Subduction Zone Earthquake and the 1000-year return period earthquake. Liquefaction potential is addressed along with recommendations regarding estimated lateral deformations of embankments and/or dynamic settlement and downdrag potential. Downdrag loads resulting from liquefaction or dynamic compaction (settlement) will be provided. Liquefaction mitigation measures and recommendations are addressed if necessary (see *BDM 1.17.4* for Liquefaction Mitigation Procedure).

1.10.5.7 Overall Stability Evaluation

The geotechnical designer shall evaluate the overall stability of the approach fills leading up to the bridge and all other unstable ground conditions, such as landslides or rockslides, that may affect the structure. This analysis shall include both static and dynamic analysis of slope stability as related to the service and extreme limit state designs. This analysis is to determine potential impacts to the bridge and approach fills which may result from embankment instability, landslide movements, settlement or other potential ground movements. A thorough geotechnical investigation, focused on slope instability, should be conducted in accordance with the ODOT Geotechnical Design Manual (GDM). Methods for evaluating overall stability and for estimating settlements and displacements are also described in the GDM. The overall stability analysis should include both non liquefiable and liquefiable foundation soil conditions as appropriate. This evaluation should be completed as early as possible in the design process to allow for possible changes in location and/or modifications to the bridge design to accommodate slope instability conditions. Coordinate with the geotechnical designer to resolve any slope instability issues that will affect the final bridge design.

For the Service Limit State, the overall stability of bridge approach fills not supporting abutment spread footings should provide a minimum factor of safety of 1.3, (roughly equivalent to a resistance factor of 0.75). A factor of safety of 1.5 against overall stability should be provided for end bent spread footings supported directly on embankments or bridge retaining walls. For bridges that are located in landslide areas, or in areas that could be affected by slide movements, the slide should be stabilized to the same factors of safety as stated above for approach fills or as determined by the region Tech Center Office and Bridge Headquarters.

For Extreme Limit State I (seismic loading) conditions, the overall stability and displacement of the approach fills should be evaluated. In addition, other potentially unstable ground conditions, such as landslides or rockfalls, should also be investigated and evaluated for their potential impacts on the structure due to earthquake forces. A minimum factor of safety of 1.1 should be provided for the pseudo static analysis of bridge approach fills, landslides and any other potentially unstable ground conditions that may affect the structure. This criterion applies to sites with or without liquefiable foundation soils. In addition to this requirement, ground displacements (lateral and vertical) should be estimated and evaluated in terms of meeting the seismic design performance criteria described in *BDM 1.17.1*. This performance criterion also applies to liquefiable or non-liquefiable foundation soil conditions. The Newmark approach is recommended for estimating the lateral displacements of approach fills, adjacent slopes, landslide masses or other ground features that may affect the structure. Other methods for estimating lateral ground deformations under seismic loading are presented in the ODOT Geotechnical

Bridge Design Manual – June 2020
Oregon Department of Transportation
Section 1 – Design Standards

Design Manual. If estimated ground displacements result in excessive deformation or damage to the bridge such that the performance criteria cannot be met, then mitigation measures should be pursued. The limits of liquefaction mitigation described in *BDM 1.17.4* also apply to all non-liquefiable soil conditions that require mitigation measures to meet the specified performance criteria.

1.11 SUBSTRUCTURES

[1.11.1 Retaining Structures, General](#)

[1.11.2 End Bents](#)

[1.11.3 Interior Bents](#)

[1.11.1 Retaining Structures, General](#)

Retaining walls that support bridge bents will typically be designed by the structure designer, and drawings will be the same size and included with the structure drawings.

For all other free-standing retaining walls, refer to the ODOT Geotechnical Design Manual, *Chapter 15*.

[1.11.2 End Bents](#)

1.11.2.1 Determining Bridge Length

Options for the end bent in relation to the end fill intersection with the finish grade include:

- Option A, no wingwalls, but a longer structure than for options B and C.
- Option B, the structure length is shorter, but short wingwalls to retain the fill.
- Option C, the structure length is shorter yet, but longer wingwalls and a taller abutment wall to retain the fill.

Generally, option B will provide the least cost, especially for prestressed slab spans. For option C, larger longitudinal forces from lateral soil loads must be resisted by the superstructure and substructure.

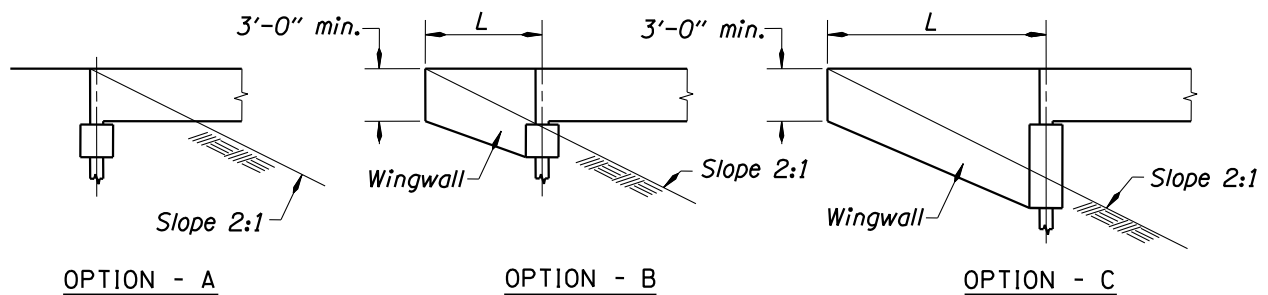
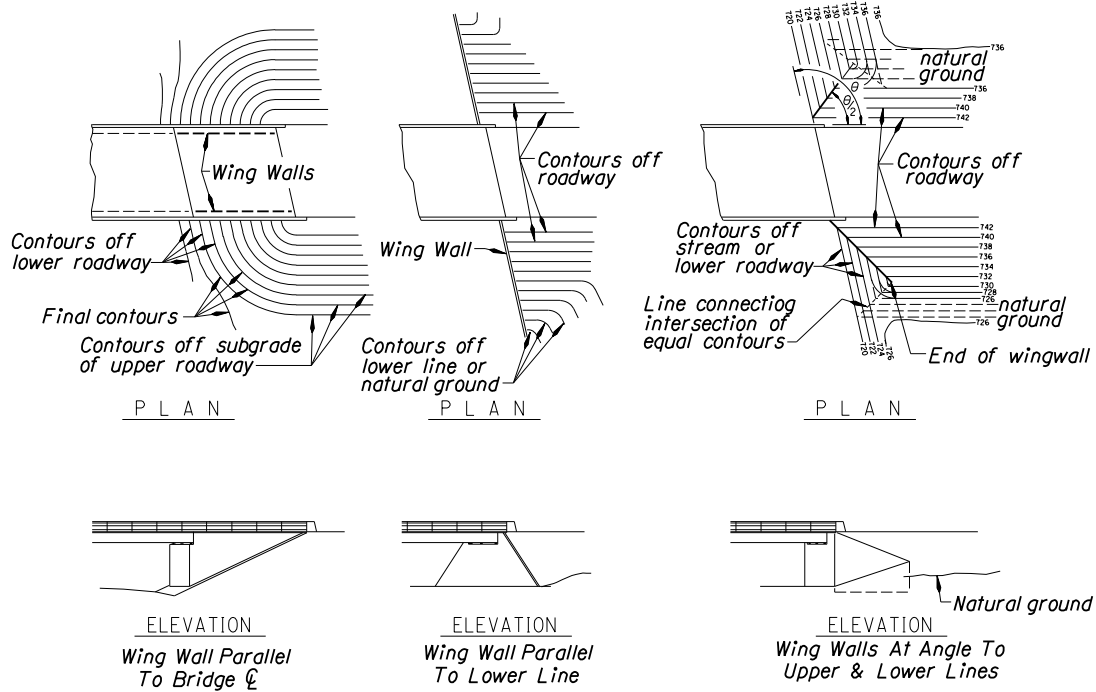

Figure 1.11.2.1

1.11.2.2 Wingwall Location

Wingwalls for end bents may be located as follows:

- Walls parallel to the structure are used for filled or "false" (unfilled) bents. These are generally used for grade separation structures where the face of the bent is quite a distance back from the toe of the slope under the structure.
- Walls parallel to bridge bents are generally avoided due to safety or stream flow considerations.
- Walls at an angle to both structure and lower roadway or stream. The angle is generally half the angle between the structure and the lower roadway or stream center lines, as this usually leads to a minimum length wall. The end of the wall is determined by plotting final contours off the upper and lower profile lines. The point where the contours of equal elevation intersect determines the location of the end of the wall.



WING WALLS AT BENTS

Figure 1.11.2.2

1.11.2.3 Wingwall Design and Construction

For cantilever wingwalls on abutments with relatively stiff footings (footing width is at least 3 times abutment wall thickness), the horizontal reinforcement in the fill face of the abutment wall resisting the moment caused by earth pressure on the wingwall need not extend farther from the wingwall-abutment juncture than the following:

- For the top 2/3 of the abutment wall height 1.5H
- For the bottom 1/3 of the abutment wall height 0.75H

Where abutment walls with wingwalls are designed with thickened tops for bearing seats or backwalls, those thickened portions should be designed to carry 1/2 to 2/3 of the bending moment in the upper half of the abutment wall. Reinforcing between the abutment wall and the wingwall should extend beyond the juncture enough to develop the strength of the bar reinforcement.

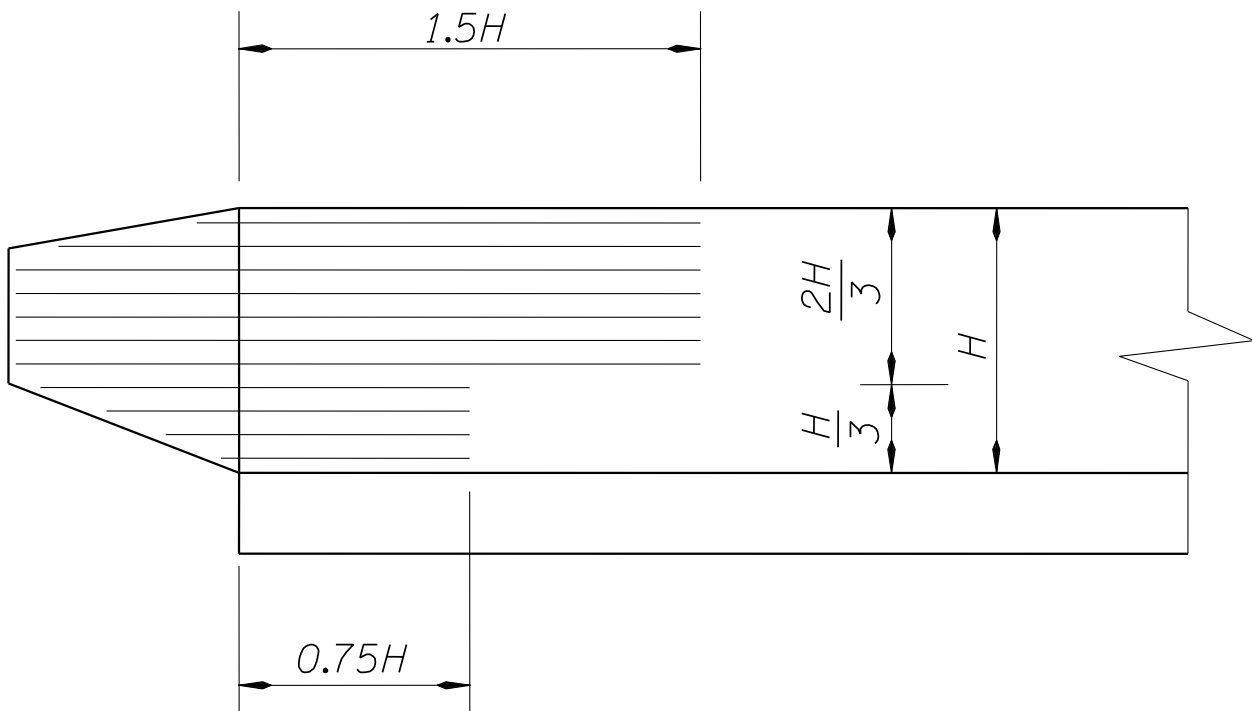

Figure 1.11.2.3A

Construction

When wingwalls are cantilevered from an abutment or pilecap, the Designer should consider all stages of construction. If the abutment or pilecap would be unstable or overstressed under the dead load of the wingwalls before the superstructure and/or backfill are placed, the "Bent Construction Sequence" on the plans should require that the concrete in the wingwalls not be placed until the superstructure and/or backfill are in place. Do not count on there being soil under the wingwall unless the wall has its own footing.

The height of the wingwall at the outer end of the wall should be a minimum of 3 feet. The slope of the bottom of the wall should be a maximum of 2:1.

The Special Provisions and detail drawings should require that the embankment fill be placed to the elevation of the bottom of the wall before the wingwalls are constructed. In other words, bridge end bent wingwalls shall be cast against undisturbed material or well compacted backfill. The designer may want to use some discretion in this matter. A 24 foot wall would normally always need to be constructed on compacted fill, while a 6' wall could be constructed and backfilled at later time.

For walls shorter than about 8 feet, the bottom of the wall can be formed level, at the discretion of the Designer or at the contractor's option. This adds some cost in materials, which may be offset by cost savings from easier construction. Potential benefits:

- Wingwalls are founded on level ground, no sloped or elevated bottom forms are required
- Adds stability to abutment
- Helps contain approach embankment at stream crossings if primary scour protection fails

Due to concerns about stability and the potential for migrating of fresh concrete over the top of wingwall forms, the slope of the top of a wingwall should not exceed the maximum slope of the adjacent embankment nor 1.5:1 without a special stability investigation.

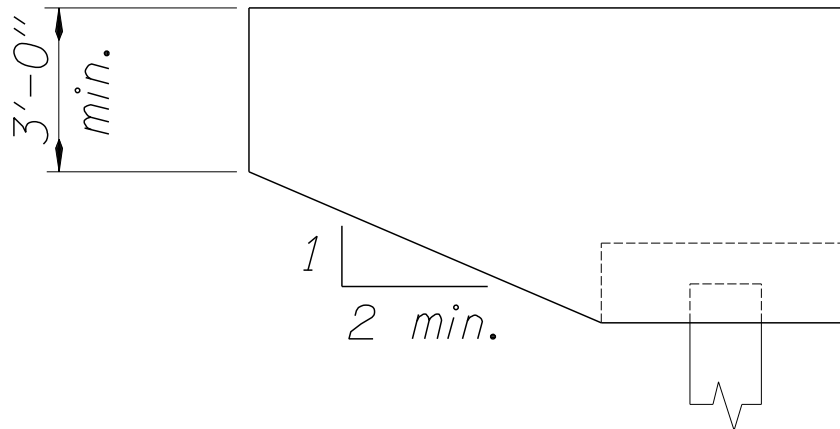

Figure 1.11.2.3B

1.11.2.4 End Bents

General

Where end bents or retaining walls are located adjacent to roadway construction, locate the top of footings at or below the elevation of the bottom of the roadway subgrade. Locate the top of the footing a minimum of 1 foot below the surface of the ground. The effect of items such as utilities, ditches and future widening should also be considered.

Terminology

In this section and elsewhere in the BDM, the terms “end bent” and “abutment” are used interchangeably. “Integral Abutment” is the industry standard term used to describe abutments that provide a continuous connection between the superstructure and the substructure. However, for consistency on ODOT bridge drawings, all bridge support locations are referred to as “bents”. Refer to the glossary in the Appendix for definitions of the terms “Abutment”, “Bent” and “Pier”. A possible exception could include the rehabilitation of an existing bridge, where the original plans called out “abutments” (or “piers”, etc.) and it would be less confusing to keep the same terminology as the existing plans.

Design

Lateral earth pressures at the end bent must be well-thought-out by both the Bridge Engineer and the Geotechnical Engineer. To more consistently model the behavior of the bridge and to ensure the design loads are constructed a [detail](#) has been developed for use in the plan set. The Bridge Engineer is responsible for including the completed detail, and pay limit diagram. The load diagram and associated notes in the plan set will be provided by the Geotechnical Engineer.

Provide access for inspection of bearings, shear lugs and backwalls for semi-integral abutments and access inspection for backwalls of integral abutment per [BDM 2.6.2](#).

Commentary:

Historically a one-foot neat-line with drain material has been used as a detail. This detail allows for easy calculation of the excavation and drain material quantities. However, the detail does not provide limits for the backfill at the end bents and wing walls and while the specifications require granular structure backfill there is not consistent direction for the extent of the backfill. Thus, there are no assurances that the designed lateral earth pressures are achieved in construction which will also limit deformation.

When Earthquake Restraining Systems and Earthquake Resisting Elements are used for passive restraint the engineering soil parameters and construction become more critical for the operational performance of the bridge. Increases in height to mobilize the passive soil pressure for seismic resistance may be necessary to achieve sufficient resistance.

Bents on MSE Walls

Refer to the ODOT Geotechnical Design Manual, *Chapter 15* for the design of MSE Walls. Provide a concrete facing for all MSE abutment walls and wing walls.

Integral Abutments

Use integral abutments wherever site conditions and structure geometry are suitable for such structures and the conditions and criteria described in this section are met. In integral abutments, expansion joints and bearings are eliminated and the superstructure is fully integral with the abutment. This results in numerous potential benefits including:

- Greater structure redundancy
- Simplified construction
- Reduced construction cost and time
- Reduced maintenance cost
- Stiffer longitudinal response at abutments

For a continuous bridge with expansion end bent connections, the interior bents take all of the longitudinal and transverse force effects. By using integral abutments in place of the expansion end bent connections, some of the longitudinal and transverse forces are distributed into the integral abutment (piles and backfill soils), thereby reducing the net forces on the interior bents. Integral abutments can reduce the longitudinal and transverse force effect considerably in a continuous bridge as compared to a bridge with expansion joints at the abutments.

Use integral abutments under the following conditions:

1. When the end bent is founded on steel pipe piles or H-piles. Do not place integral abutment foundations on top of, or through, MSE retaining wall reinforced backfill. For all other foundation types, see [guidelines for semi-integral abutments](#).
2. When bed rock is a minimum of 12 feet from the bottom of the pile cap. Avoid using pre bored piles when bed rock is close to the surface, since this type of construction has been uneconomical.
3. When there is negligible potential of abutment settlement which does not affect the serviceability of the bridge.
4. When the radius of horizontal curvature is greater than 1200 feet.
5. When the skew angle is less than 30 degrees.
6. When, for all service limit states, movement at the top of integral abutment piles does not exceed ± 1.5 inches from the undeflected position. The corresponding range of pile movement is therefore 3.0 inches if the superstructure is made integral with the piles at the mean annual temperature.

Design Guidelines for Integral Abutments:

1. Use a U-shaped abutment (wingwalls parallel to roadway alignment) if possible.
2. Use H-pile with strong axis in the direction of temperature movement. See [Figure 1.11.2.4A](#).

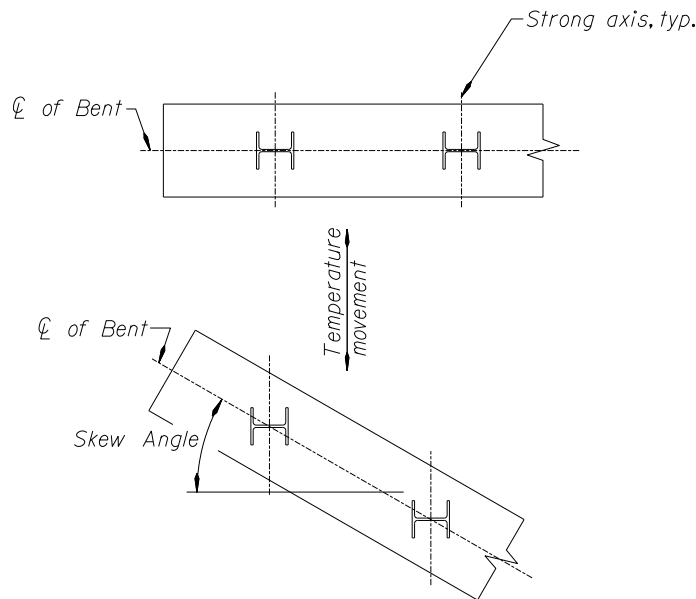

Figure 1.11.2.4A

3. Embed piles into the pile cap to develop moment fixity. See [BDM 1.10.5.4 Piling Details \(1\)](#)
4. Preboring may be necessary in some cases where pile design stresses are excessive due to thermal movements and cannot be accommodated without special foundation design and construction. The cost of preboring for the piles should be compared to the benefits gained by

using an integral abutment design. Increasing the number of piles or the use of larger piles in the abutment may decrease individual pile stresses to acceptable limits. If preboring is required, and cost effective, then consider preboring an oversized hole. The prebore dimensions should be at least 4 inches or more in diameter larger than the diagonal dimension of the pile and large enough to accommodate the estimated pile deflection. Backfill the area around the pile with loose sand conforming to the current *SP 00360.10* or as recommended by the Geotechnical Designer. Do not compact the sand backfill material. Bentonite or pea gravel backfill are not recommended since they may not provide for the long term flexibility required of the pile and soil system. The depth of prebore should be 10 feet or more or as required to provide the required pile flexibility to decrease pile stresses to an acceptable limit.

5. Detail piles of integral abutments to resist uplift force from temperature differential between top and bottom of the pilecap. Refer to *Figure 1.10.5.4.E* for pile anchorage details.
6. The design of integral abutment bridges with a grade change between abutments should consider both vertical and horizontal components of bridge longitudinal loads such as uniform temperature changes, creep, shrinkage, braking, seismic, and lateral earth pressure, on the resulting axial and flexural stresses in the piles.
7. Develop a LPILE model using the full pile for soil and pile interaction. Evaluate pile deflections, bending moments and stresses using LPILE computer program analysis.
8. At the service limit state, H-pile flange yielding at each flange tip should not exceed 5 percent of the total flange area. See *Figure 1.11.2.4B*. For steel pipe piles no yielding of section is permitted.

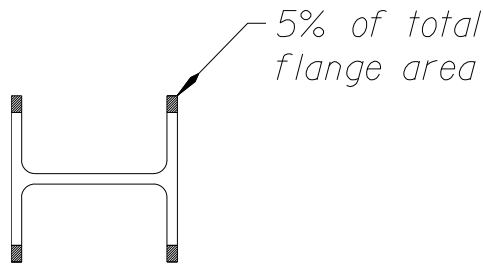

Figure 1.11.2.4B

9. Consider the relative stiffness of the superstructure, substructure and any asymmetric span lengths in calculating end bent movement. Consider the potential for unequal thermal movements at end bents (integral abutments) due to asymmetric span lengths or changes in substructure stiffness.
10. Consider torsion in components connected to integral abutments.
11. Consider the combination of worst case events (except seismic) with temperature rise and fall.
12. Specify placement and compaction requirements and an increased frequency of field density test requirements of the backfill material (minimum of two tests per stage of construction at each end bent) to achieve consistent soil stiffness behind both end bents.
13. Consider the friction force between the bottom of the impact panel and structure back fill (expansion and contraction) in the superstructure design at the service limit state. Assume a friction coefficient of 0.54 unless specific measures are taken to reduce friction.

Bridge Design Manual – June 2020
Oregon Department of Transportation
Section 1 – Design Standards

14. Connect superstructure and end bents with a closure pour. Require a minimum of three days wait period between concrete deck placement and closure pour to release shrinkage stress in bridges with steel superstructures and include long term creep in your design for concrete superstructures. Include a note which requires backfill behind the abutment after closure pour.
15. Where the range of abutment movement is 1 inch or less, the end panel may be fixed to the superstructure and thermal movements accounted for by providing a saw cut in the approach pavement at the end of the end panel. Where the range of abutment movement exceeds 1 inch, provide an expansion joint between the end panel and the deck so the end panel is not dragged back and forth with thermal expansion and contraction. See *Figure 1.11.2.4C*.
16. In integral abutment bridge staged construction, a continuous abutment is capable of transferring traffic live load vibrations in one stage to the girders and the deck that are under construction in another stage. These vibrations can damage fresh concrete in the deck. To minimize these vibrations, provide an expansion joint or closure segment in the integral abutment located between the stages of construction.
17. Specify deck casting sequences and deck closure pours at integral abutment connections and specify the range of temperature when the contractor may place the concrete on the plans and in the special provisions. Keep the range of temperature in the closure pour to not adversely affect the pile stress during temperature fall or rise.
18. See design example in the following publication of the American Iron and Steel Institute HIGHWAY STRUCTURES DESIGN HANDBOOK, Vol. II Chapter 5, "Integral Abutments For Steel Bridges", prepared for the National Steel Bridge Alliance by Tennessee DOT.

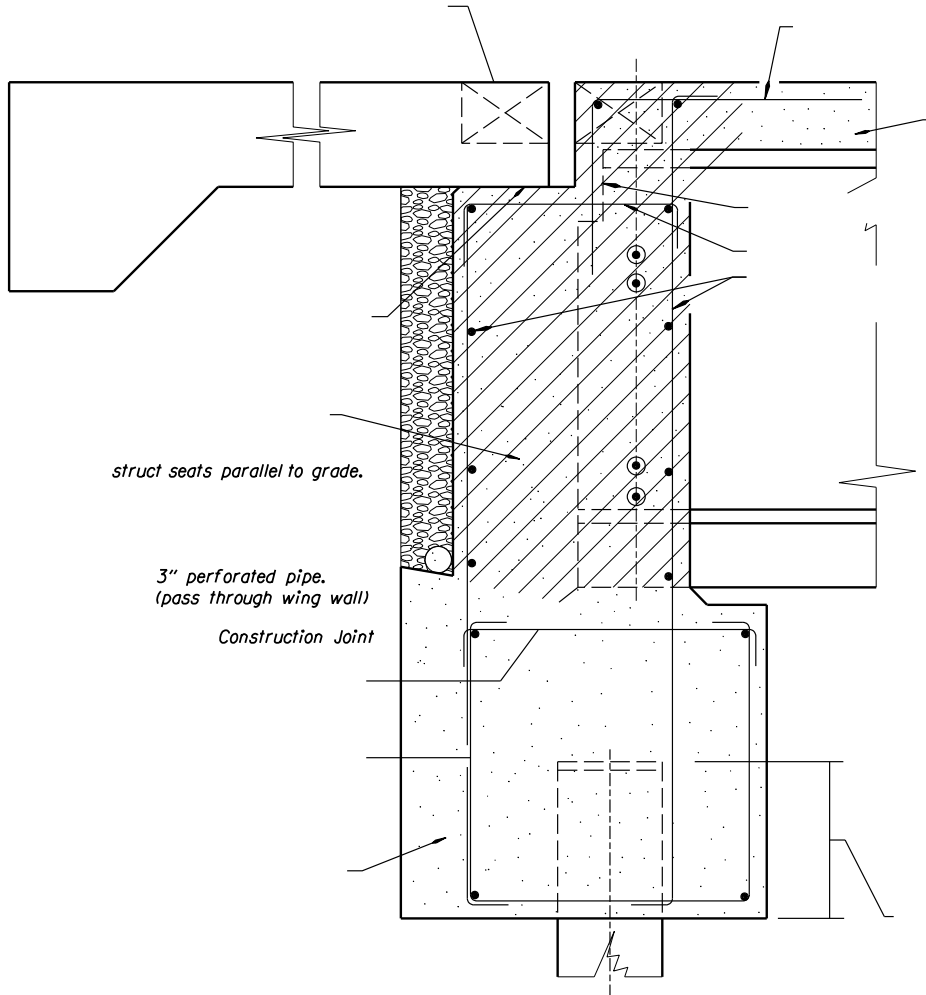

Figure 1.11.2.4C

Semi-Integral Abutments

Recommendations for integral abutments also apply to semi-integral abutments, except as noted in this subsection.

Consider the use of semi-integral abutments, rather than integral abutments, on foundations that are stiff in the longitudinal direction, such as spread footings, drilled shafts, and concrete piles. These foundations do not provide the required flexibility in the longitudinal direction required for integral abutments. Also consider semi-integral abutments, rather than integral abutments, when the abutment is founded on top of or passes through MSE retaining wall reinforced backfill.

Two points that need to be evaluated on semi-integral abutments (especially on skewed bridges) are torsional forces affecting the bearings, and the effectiveness of shear keys used. If geometry requires a stiff footing, this type of construction is recommended.

For skewed bridges, consider the load path from thermal forces to the substructure. Skewed semi-integral abutments may rotate (finish condition).

1.11.2.5 Strutted Abutments

Abutments of single span bridges with the superstructure in place before backfilling may be designed using the strutting action to resist earth pressure overturning. For such abutments, apply soil pressure based on an at-rest or neutral condition of the soil. Footings for these abutments are not required to satisfy the "uniform bearing" under the dead load requirement. Investigate the bridge for the case of backfill being washed out behind one abutment. For this case, use active soil pressures with no live load surcharge on the opposite abutment. A factor of safety against overturning of the whole structure of 1.25 will be considered adequate, and 125 percent of the allowable bearing pressure will be acceptable.

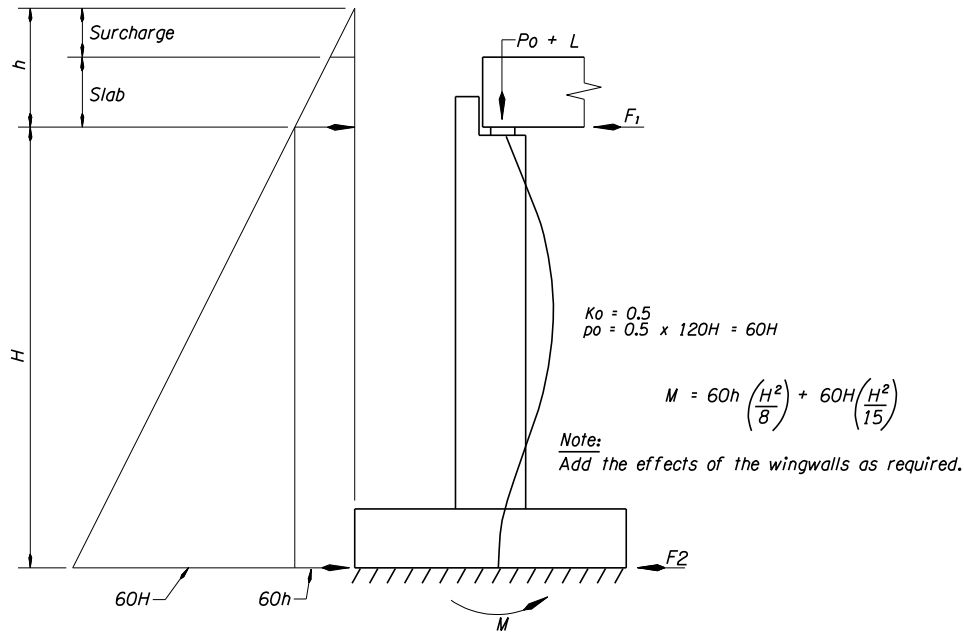

Figure 1.11.2.5A

1.11.2.6 Pile Cap Abutment Details

Pile Cap Elevations - Show the bottom of the pile cap elevations on the pile cap "Elevation" view. If the pile cap is sloped, show the elevation at each end.

Fixed (Integral) action – Double row of reinforcing bars provides the connection between superstructure and substructure. Shear and moment are transferred. Pile embedment to develop fixity is required, if the number and size of piles are selected to resist a specified load.

Bridge Design Manual – June 2020
Oregon Department of Transportation
Section 1 – Design Standards

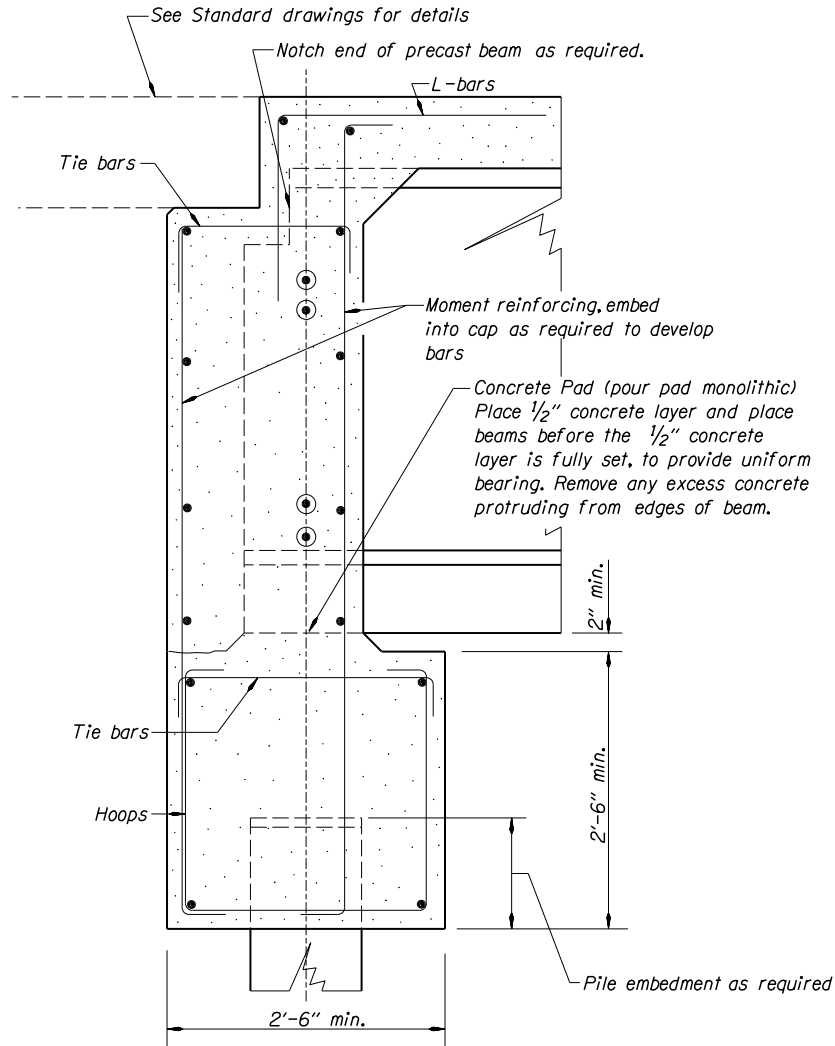

Figure 1.11.2.6A

Fixed (Integral) action with elastomeric bearing pads – This option allows the use of a 1/2 inch elastomeric bearing pad to be placed on top of the concrete grout pad. The precast beam can then be placed on top of the pad prior to the placement of the full width backwall. The beam should be placed just after a wet 1/2 inch grout layer has been placed under the bearing pad as specified in [BDM 1.14.1.6](#). A double row of reinforcing bars provides the connection between superstructure and substructure. Shear and moment are transferred. Pile embedment to develop fixity is required, if the number and size of piles are selected to resist a specified load.

A reinforced concrete pad is required to resist temporary bearing loads. Hand placement of grout under the bottom flange of the beam may be required to fill the 2-1/2 inch gap.

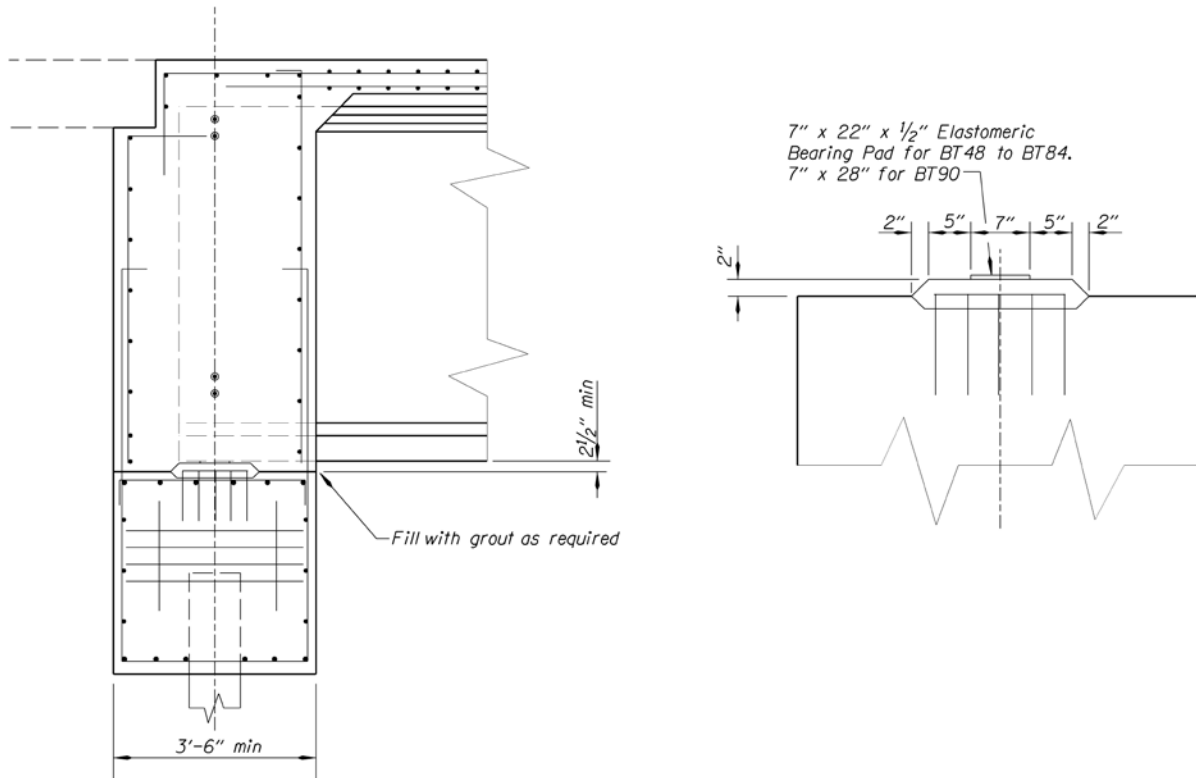

Figure 1.11.2.6B

The performance of the 1/2 inch bearing pad under the vertical load and rotation resulting from deck load and diaphragm load was evaluated according to *LRFD 14.7.6.3.5b* for BT48 to BT90 girders. For BT48 to BT84 girders, a 7" x 22" pad is required. For BT90 girders, a 7" x 28" pad is required. Beam weight was not included in the end rotation calculations because the wet grout layer placed below the elastomeric pad at the time of beam placement eliminates any rotation of the pad due to beam end rotation from beam dead load.

Expansion allowed (nominal amount of movement) – No reinforcement is provided between the superstructure and substructure. This type is appropriate when nominal movement is expected on a non-yielding type of foundation.

Bridge Design Manual – June 2020
Oregon Department of Transportation
Section 1 – Design Standards

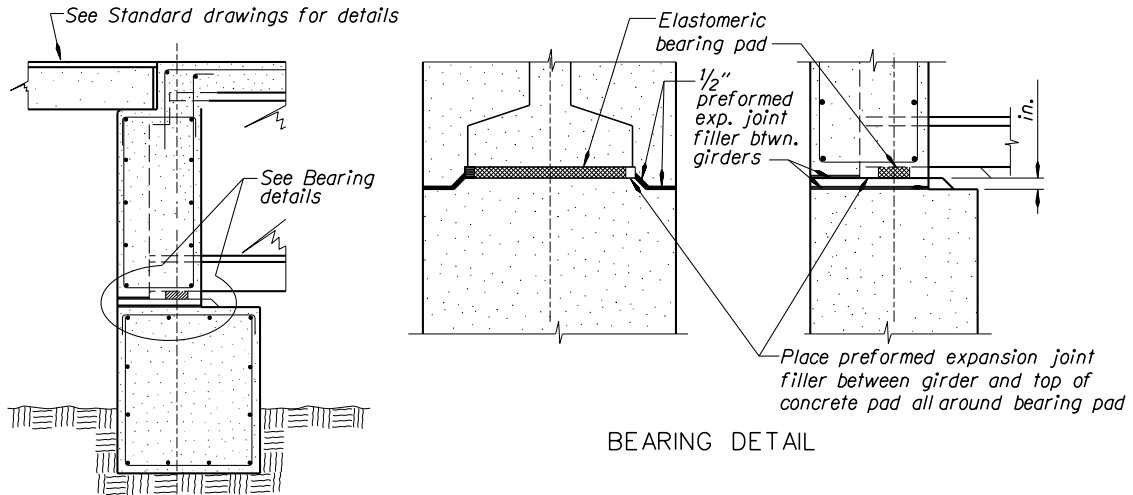

Figure 1.11.2.6C

Expansion allowed (movement allowed as required) - No reinforcement is provided between the superstructure and substructure. This type is appropriate when movement needs to be accommodated in the design. Various types of bearings and joints can be used for the movement required.

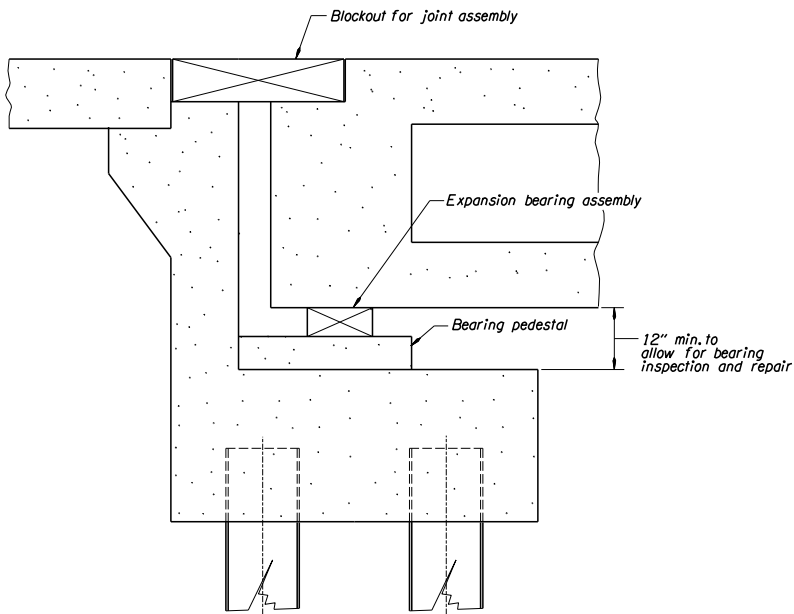

Figure 1.11.2.6D

1.11.2.7 **Abutment Details for Prestressed Slabs**

See *BDM Appendix 1.11* for Prestressed Slab End Bent Design/Detail Sheets for more details.

Shallow Abutments (Pile Cap) – Precast Slab or Box

Most common and most economical type of end bent. It requires the least amount of excavation and cast-in-place concrete.

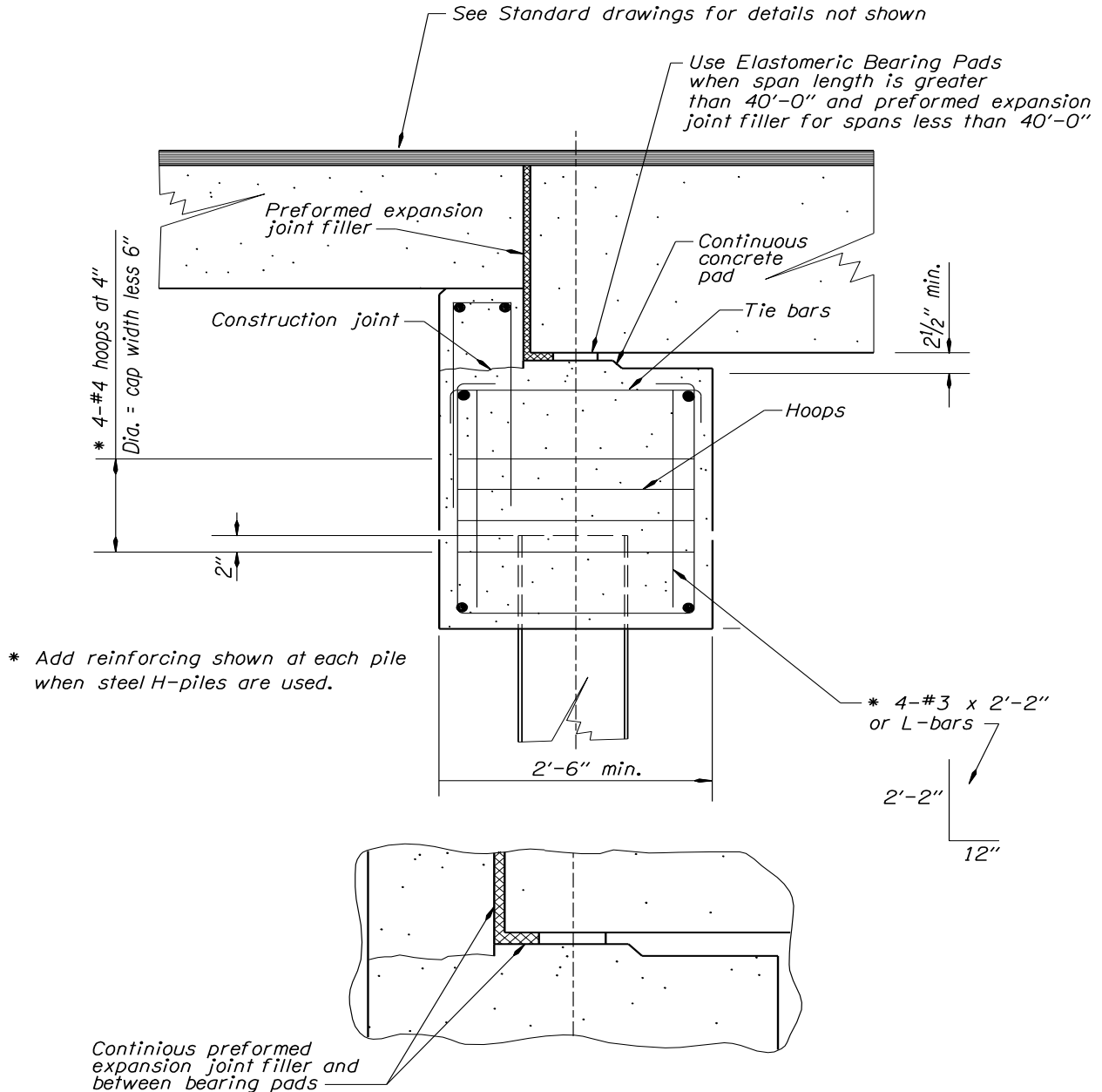

Figure 1.11.2.7A

Partial Depth Abutment – Precast Slab or Box

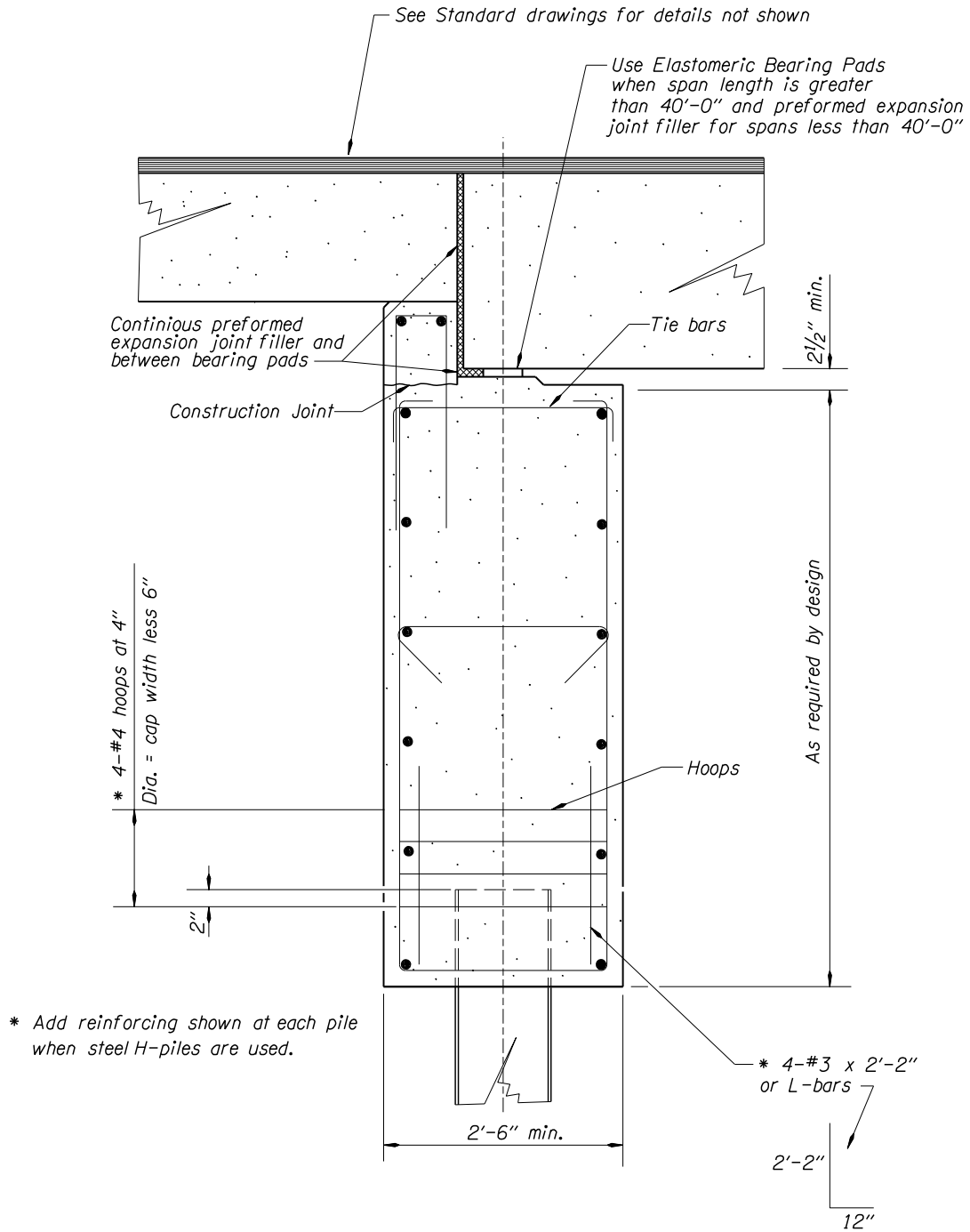

Figure 1.11.2.7B

1.11.2.8 Forming of Backwalls for End Beams

Details should be developed that will allow the removal of forming materials. Forming materials, including expanded polystyrene must be removed. Forming material is normally not yielding and can cause cracking as the structure expands and contracts.

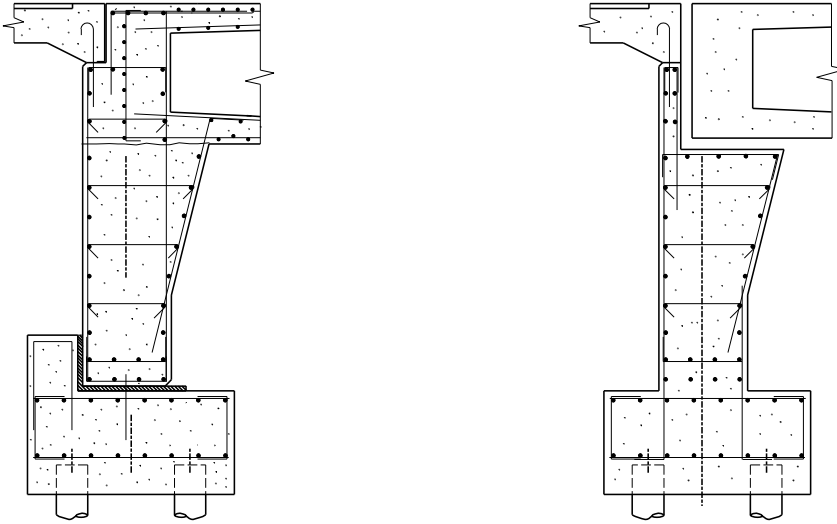

Figure 1.11.2.8A

1.11.2.9 Bent Joint Details

Provide an open joint between the abutment and the deck-and-girder section, as shown below. Note on the plans of post-tensioned structures that if expanded polystyrene is used to form the joint, it must be removed before tensioning.

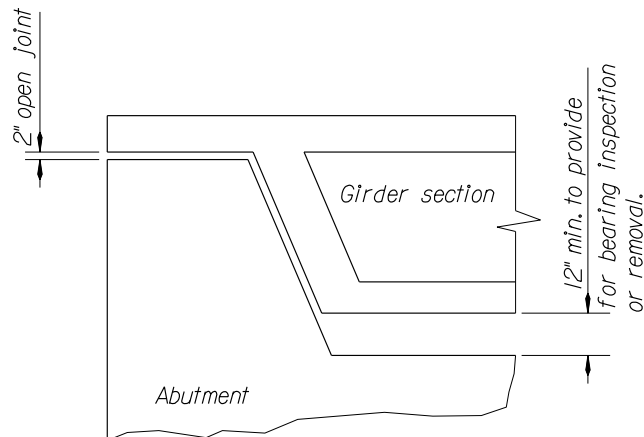

Figure 1.11.2.9A

1.11.2.10 Backwall Reinforcement for Post-tensioned Structures

When detailing the vertical reinforcement for the backwalls of abutments for post-tensioned spans, the Designer should take into account the location of the post-tensioning anchorages. Spacing of bars and/or splicing details should be such that the vertical bars do not have to be bent out of the way for the post-tensioning operation and bent back to their final positions.

1.11.2.11 Beam Seat Drainage

Slope the beam seats of abutments to drain away from the front face. Provide scuppers through the bearing pedestals and backwall or drain pipes at low points to pick up any water that might leak into this area.

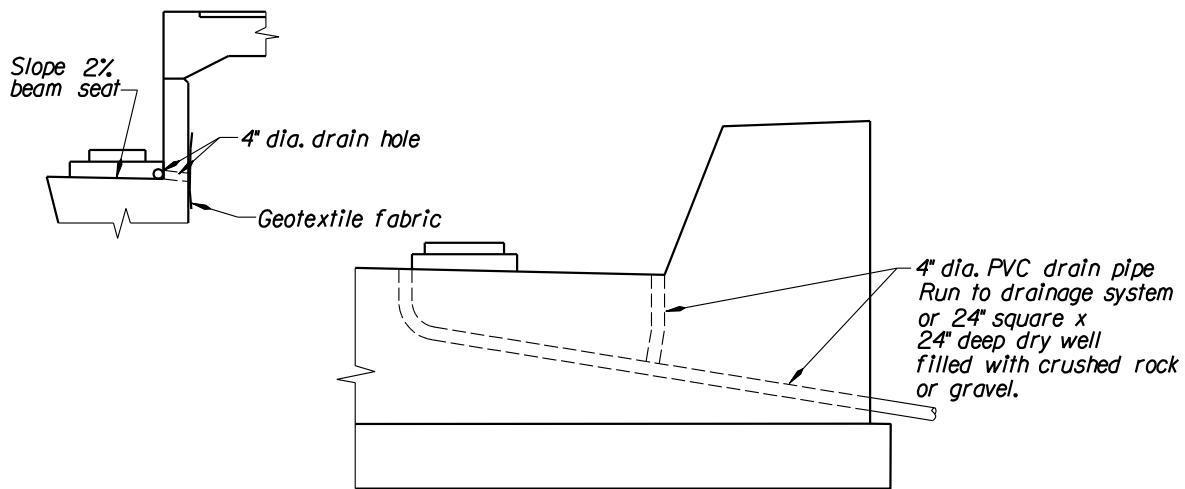

Figure 1.11.2.11A

1.11.2.12 Reinforced Concrete End Panels

See [BDM 1.23](#) for end panel requirement criteria. Detail all bridges with paving ledges or other provisions so that present or future reinforced concrete end panels can be supported. Detail structures with sidewalks with a ledge or other provision to support an approaching concrete walk (present or future) if there is no approach slab in the walk area. When reinforced concrete end panels are required, show them on the bridge plans and include them in the bridge quantity estimate. In most cases, the bridge rail should be extended to the end of the end panel.

1.11.2.13 Bent Width Provisions with Precast Units

All pile caps, crossbeams, abutments, etc. supporting adjacent precast units (such as slabs, boxes, integral bulb-T's, etc.) should be detailed for the total width of all units with an additional width of a minimum of 1/2 inch per precast unit. This is required because unit fit-up is not exactly true and "growth" in width occurs. The 6 inch minimum closure pour on each side of the exterior units at abutments as shown on End Bent Detail drawing may be used for adjustment due to these misfits. The 6 inch dimension may be increased where necessary for wider roadways.

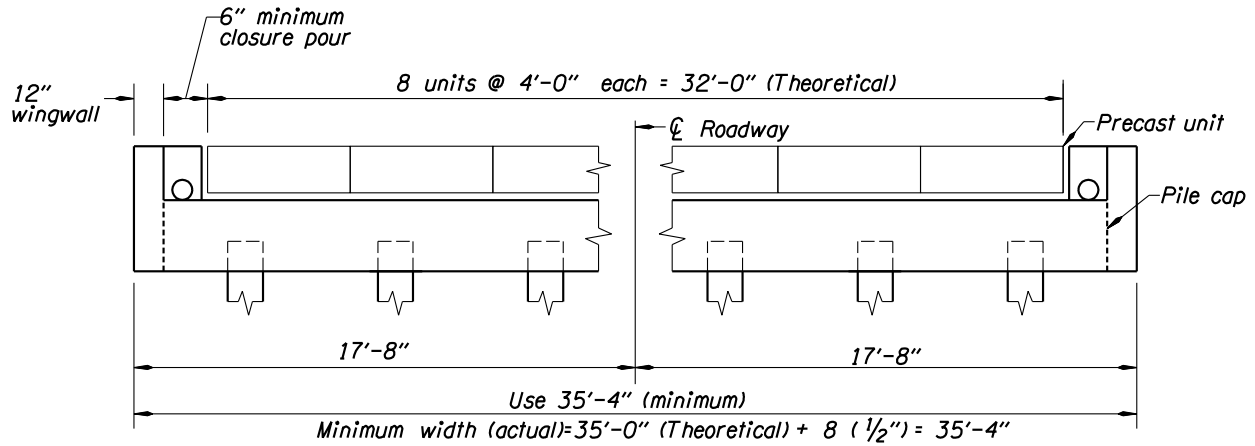

Figure 1.11.2.13A

1.11.3 Interior Bents

1.11.3.1 Interior Bents, Design and Detailing

Design

Design structure for stability under all stages of construction. The following conditions, in particular, should be checked:

1. Stream flow and wind load w/o superstructure.
2. Dead load of one or more girders plus wind load and stream flow. Note: Contractor is responsible for stability of girder itself.
3. Lateral system must be sufficient to insure stability of girders under wind load without deck.
4. Top flanges must have sufficient support not to buckle under dead load of (fluid) concrete without the aid of deck forms.

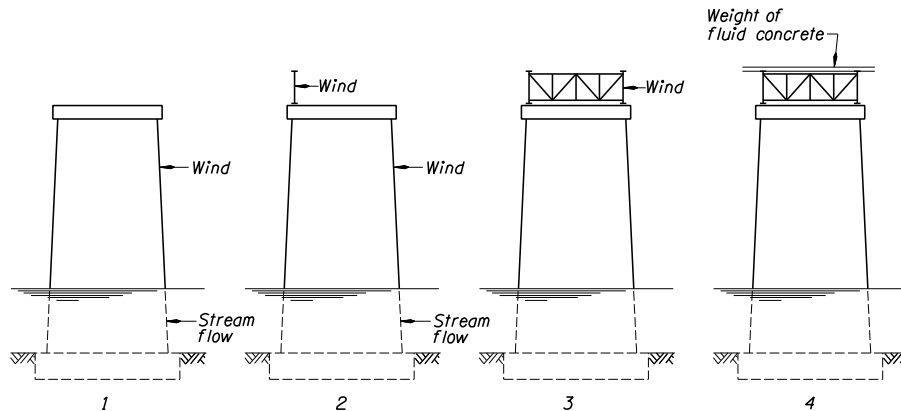

Figure 1.11.3.1A

Effective Span Length

When computing the maximum negative moment for a crossbeam on a column or pier, the crossbeam may be considered to be supported by a concentrated reaction, the following distance inside the face of the column or pier:

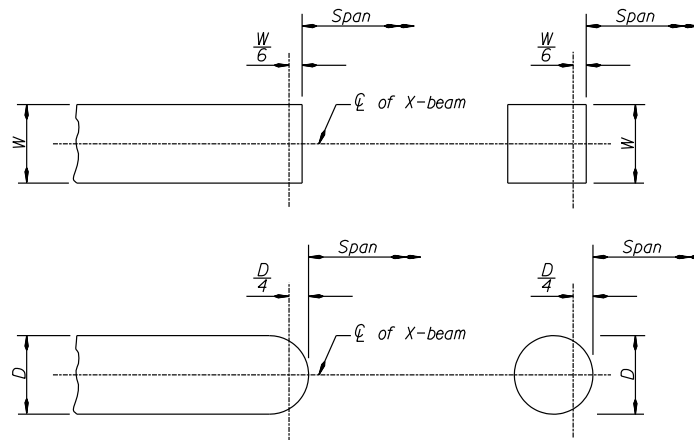
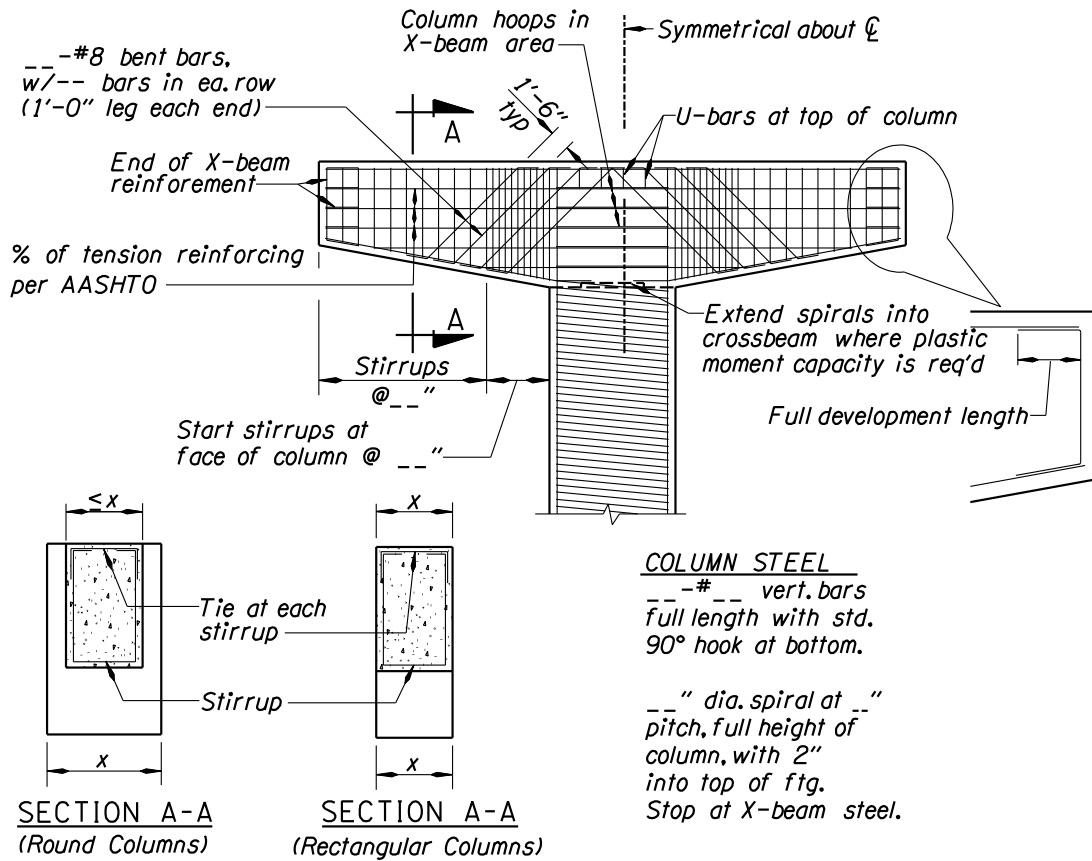

Figure 1.11.3.1B

Detailing

Provide all dimensions and details necessary for the reinforcing steel fabricator and contractor to construct it.



NOTE:
 X-beams, columns and footings should be sized to be structurally adequate and esthetically proportional.

Figure 1.11.3.1C

See [BDM 1.11.3.5](#) and [BDM 1.11.3.6](#) for details of column reinforcing.

1.11.3.2 Interior Bent Details for Prestressed Slabs

- See [BDM Appendix 1.11](#) for Prestressed Slab Interior Bent Design/Detail Sheets.

1.11.3.3 Structure Widening, Interior Bents

Generally, connections between structure bents should be detailed to tie the structures together, but prevent dead load and concrete shrinkage loads from being transferred to existing bents.

Example details are shown below and on the following pages.

The method below allows the new x-beam to deflect during the construction loadings with minor load transfer to the existing crossbeam.

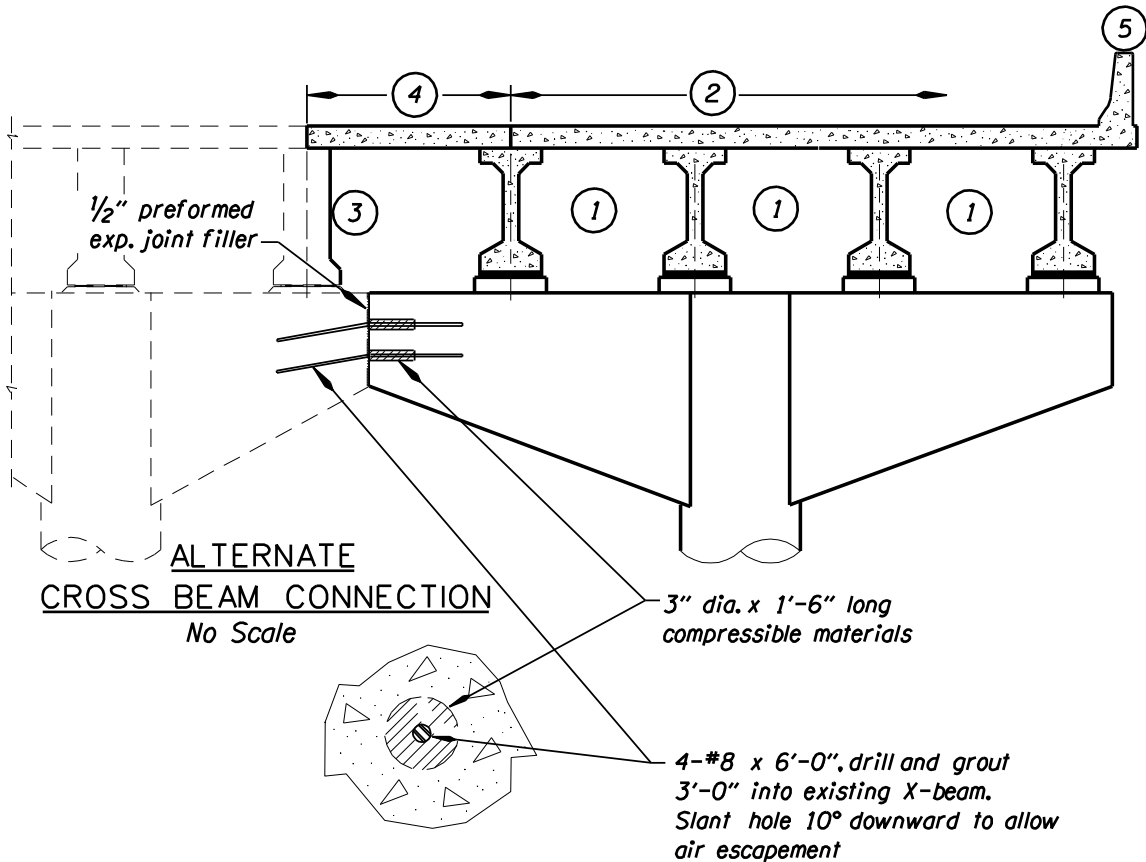

POUR SCHEDULE
(INCLUDING CLOSURE POUR)

- | | |
|---|--|
| <p>① Make pour in end beams and diaphragms</p> <p>② Make pour in deck slab. Delay pour ② a min. of 3 days after pour ①. A transverse deck construction joint may be made at any diaphragm beam. Delay pouring adjacent deck sections a minimum of 36 hours.</p> | <p>③ Make pour in end beams and diaphragm of closure pour section.</p> <p>④ Make pour in deck slab of closure pour. Delay a minimum of 3 days after pour ③.</p> <p>⑤ Make pour in bridge rail.</p> |
|---|--|

Fig. 1.11.3.3A

The method below allows the widening construction to be completed before the connecting bars are grouted and able to transfer loading from the new crossbeam to the existing crossbeam.

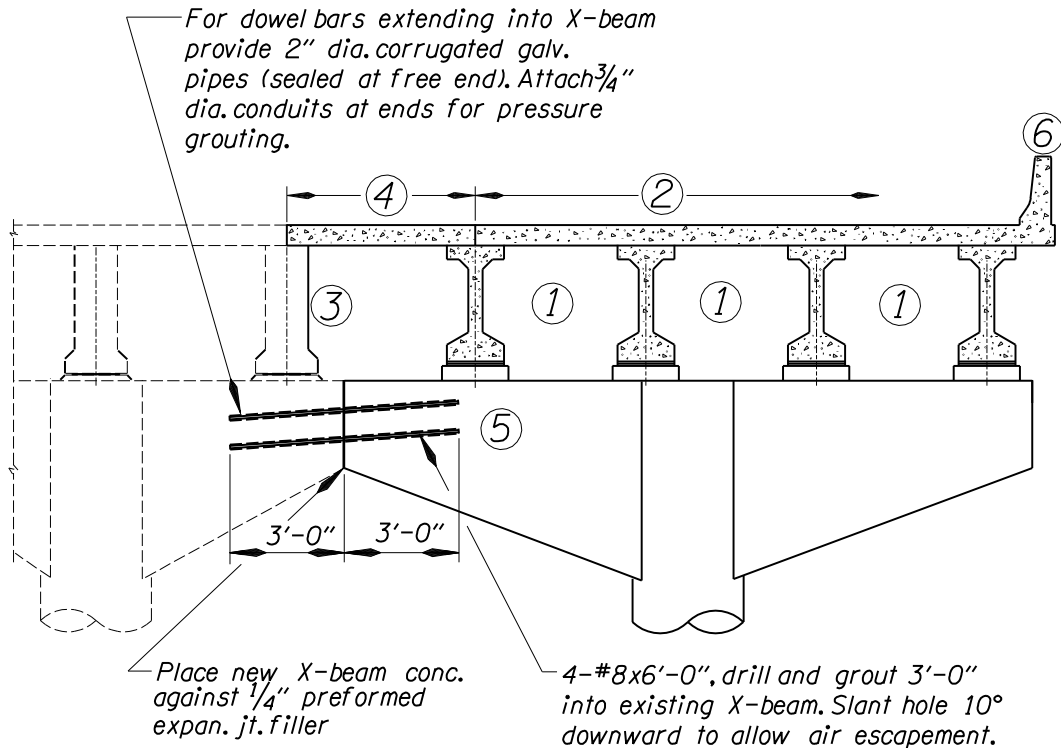

CROSS BEAM CONNECTION AND
 CLOSURE POUR DETAIL

No Scale

POUR SCHEDULE
 (INCLUDING CLOSURE POUR)

- ① Make pour in end beams and diaphragms
- ② Make pour in deck slab. Delay pour ② a min. of 3 days after pour ①. A transverse deck construction joint may be made at any diaphragm beam. Delay pouring adjacent deck sections a minimum of 36 hours.
- ③ Make pour in end beams and diaphragm of closure pour section.
- ④ Make pour in deck slab of closure pour. Delay a minimum of 3 days after pour ③.
- ⑤ Pressure grout dowels in cross beam.
- ⑥ Make pour in bridge rail.

Figure 1.11.3.3B

1.11.3.4 Columns in Slopes

Special attention should be given to situations where new fill could exert lateral pressure against bents other than the end bents. Such situations may require special construction sequence notes and/or special footing design including battered piling.

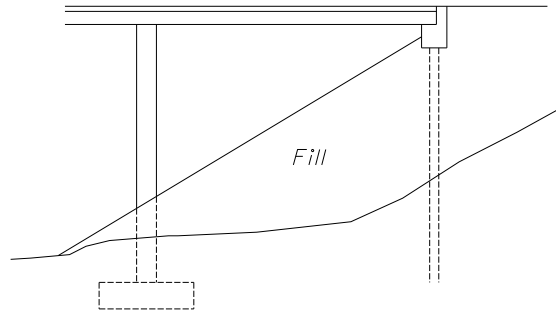

Figure 1.11.3.4A

1.11.3.5 Column Design, General

See *BDM Appendix 1.2* for column loading criteria for vehicular impact, depending on type and location of barrier used (ODOT Instructions for *LRFD 3.6.5*).

For column designs controlled by seismic loading, provide shear and confinement reinforcement detailing according to *2nd edition of AASHTO Guide Specifications for LRFD Seismic Bridge Design, Section 8.6*.

For both tied and spiral columns, ensure adequate space for man access for tying and inspection.

Multiple interlocking spirals are the preferred choice for non-circular columns. Use 0.75 spiral diameters as the maximum center-to-center spacing of spirals. In this way, the smaller column dimension will dictate the larger column dimension. Closer center-to-center spacing of spirals is possible but would reduce the access space for tying and inspection. At least 4 vertical bars must be placed within the spiral overlap area. A photo log from FHWA is available showing how multiple spirals have been constructed.

Corners will normally be filleted or rounded. Using rectangular corners would normally require nominal corner vertical bars with ties developed within the core area. Such ties would interfere with bar tying and inspection. Therefore, design corners to be considered "expendable" in an earthquake, by detailing the rebar so that it is not developed within the core.

Bundled bars should only be oriented tangentially (both bars touching the spiral). Multiple concentric rings of bars are not a constructible option with multiple interlocking spirals, but may be used in detailing of circular columns.

Apply *LRFD equations (5.7.4.6-1, 5.10.11.4.1d-1, 5.10.11.4.1d-2 and 5.10.11.4.1d-3)* using volumes for a single spiral, using a theoretical minimum-cover column with 2 inches of cover to determine gross area in these equations. The maximum spiral yield strength to be used in determining spiral spacing is 60 ksi. The heavier spiral confinement requirements for plastic hinge areas do not apply to tops of columns that are pinned.

Where columns are supported by drilled shafts, use a non-contact splice as shown in *Figures 1.10.5.5A or 1.10.5.5B*. Ensure column diameter is less than shaft diameter according to *BDM 1.10.5.5(1)*. Provide

confinement reinforcement meeting the requirements in *LRFD 5.10.11.4.1d* for column segments extending into drilled shaft as shown in *Figures 1.10.5.5A* and *1.10.5.5B*.

Specify ASTM A706 reinforcement for vertical column bars when columns are supported on drilled shafts or when plastic hinging is anticipated in either the top or bottom of the column.

Specify 3/4 inch maximum aggregate size in footings, columns and crossbeams. To maintain the shape of the spirals, use a maximum vertical bar spacing of 8 inches.

Containing an 8 inch diameter drain pipe within the column and taking it out between spread bars at the bottom is not an option since confinement requirements would be violated.

1.11.3.6 Spiral Reinforcing

Use spiral reinforcing for all columns. For column designs not controlled by seismic loading, extend spirals from a minimum 2 inches below the top of the footing to the bottom of the steel in the cross beam or longitudinal beam.

Where plastic moment capacity is required between column-to-crossbeam connections, extend the spirals into the crossbeam to the top crossbeam steel.

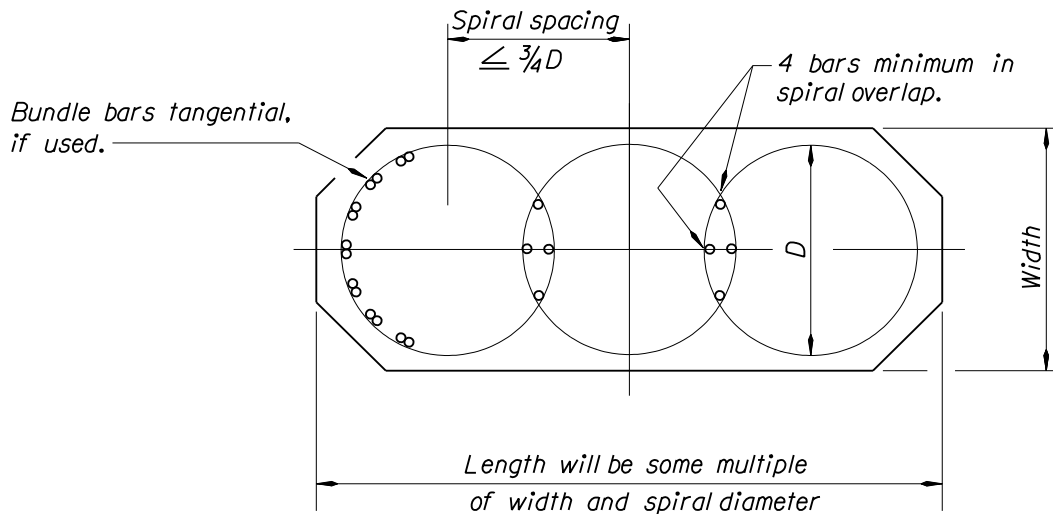

Figure 1.11.3.6A

The following notes apply to the specification above and are for designer information only:

- Deformed bars (ASTM A615 Grade 60 or ASTM A706) can be specified in sizes from #3 through #6.
- A706 is formulated to be weldable so submission of chemical analysis is unnecessary. It is also preferred because it is the most ductile.
- A1064 plain steel wire cannot be mechanically spliced because it lacks deformations. It is available only in sizes 5/8 inch diameter or less.

Bridge Design Manual – June 2020
Oregon Department of Transportation
Section 1 – Design Standards

- ASTM A1064 and A615 Grade 60 bars are available in coils. Average A1064 bar coils have a weight of approximately 1500 pound, and A615 deformed bar coils have a weight of 3000 pound to 4500 pound, depending on the size of the bar.
- For ease of handling, spirals are generally fabricated without splicing in weights up to a maximum of 200 pound per piece for diameters 8 feet and under.
- Coated spiral bars are fabricated using ASTM A706 bars. Stock lengths are generally 40 feet to 60 feet. Bars are spliced using the weld lap splice method. Maximum shipping mass is 200 pound for ease of handling and protection of the coating.
- Approved mechanical fasteners may be used provided the full strength of the bar is developed.
- Use of lapped splices should be avoided because of the 80d lap requirement and because hooks into the core will inhibit access for tying and inspection. Use of lapped splices is not permitted for spirals less than 3'-0" diameter. Although the lap splice detail is structurally acceptable, and permissible by the code, it causes construction challenges. While casting concrete, the tremie gets caught in the protruding 10 in. hooks, making accessibility to all areas and its withdrawal cumbersome.
- The plans should state the type of spiral reinforcement used in computing reinforcing quantities. Normally the Designer should assume A706 with welded splices.

Standard spiral splice and termination details are shown below.

NOTE A:

Use ASTM A706 for all welded splices, except ASTM A615 Grade 60, ASTM A1064 may be used if copies of the chemical composition analysis are submitted and approved as weldable by the Engineer. Anchor spirals at each end or discontinuity with one extra turn and a splice to itself as shown. Where permitted on plans, provide closed hoops conforming to the requirements of this detail. Lapped splice is not allowed within $\frac{1}{6}$ the column height or max. column cross sectional dimension or 18" from top of footing or bottom of cap beam, or in columns with spirals less than 3'-0" in diameter.

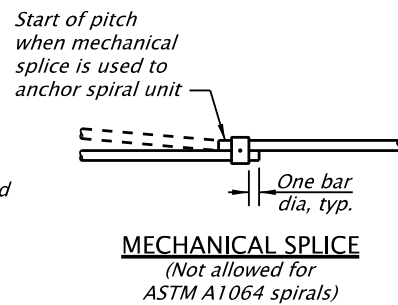
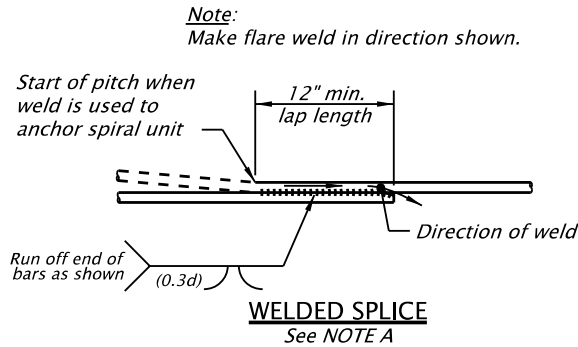
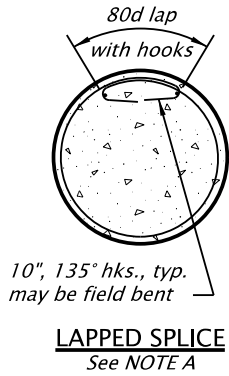

SPIRAL SPLICE/TERMINATION DETAIL

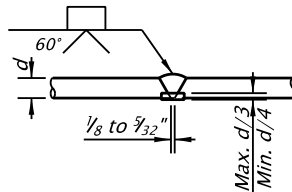

ALTERNATE WELDED SPLICE
(EXCEPT ASTM A1064)

Weld reinforcing steel splices in accordance with ANSI/AWS D1.4 "Structural Welding Code Reinforcing Steel"

Figure 1.11.3.6B

1.11.3.7 Column Steel Clearance in Footings

Column steel hooks are placed on top of the footing mat to avoid the need for threading footing steel through the column steel cage.

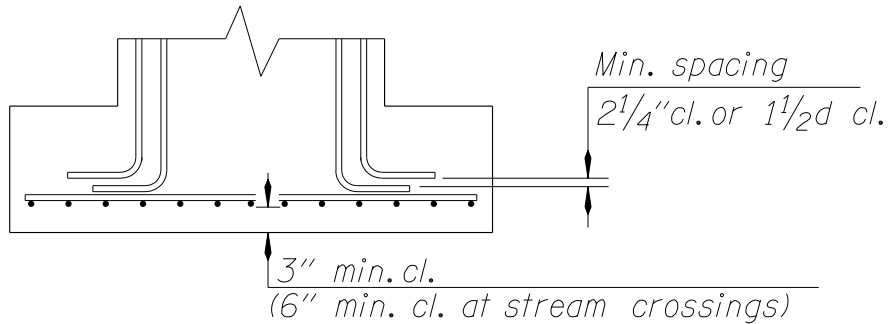

Figure 1.11.3.7A

1.11.3.8 Column Hoops

Due to seismic requirements, use hoops and ties only to supplement spiral reinforcement for architecturally shaped columns to provide some confinement to concrete that is "expendable" in a major seismic event. Terminate these supplemental hoops and ties without the normal extension (hooks) into the interior mass of the column concrete. Because these architectural features are expendable and are not considered in the analysis and design we want to allow their failure. They should be detailed so they do not add undesired stiffness and strength.

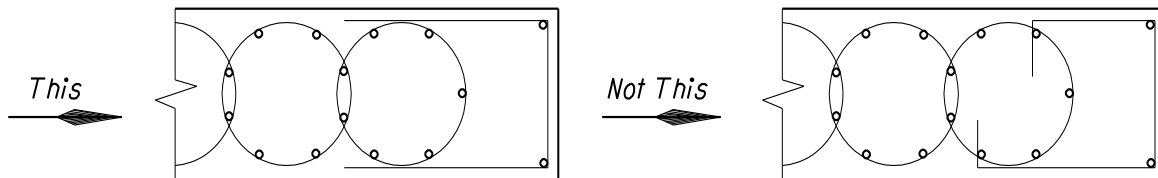

Figure 1.11.3.8A

1.11.3.9 Vertical Bar Splices

Do not splice vertical column bars for columns less than 30 feet in length (no footing dowels). For longer columns, splices may be made as shown below in the middle 1/2 (preferably at mid-height) of the column (outside the plastic moment areas). Lap splice is allowed for #11 bars and smaller. For #14 and #18 bars Type 2 mechanical splice is required. Type 2 mechanical splice is required to develop at least 125 percent of the specified minimum yield strength and 100 percent of the specified tensile strength of the reinforcing bars.

The development requirements may require 180 degree hooks of the column verticals in the cap beam. Pay attention to how the column verticals, extended spirals, bottom cap beam bars, and post-tensioning ducts all fit together.

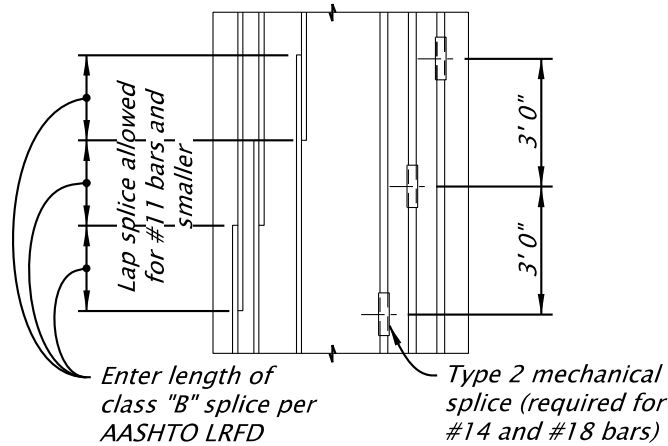
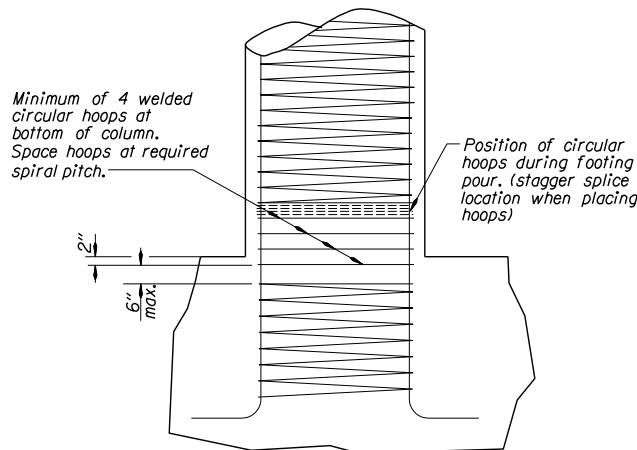

Figure 1.11.3.9A

1.11.3.10 Optional Hoop Detail at Bottom of Column

The detail below will facilitate more effective concrete placement in the core area of the footing. The 6 inch gap is used to facilitate placement of the top mat of reinforcement.



OPTIONAL HOOP DETAIL AT BOTTOM OF COLUMN

Figure 1.11.3.10A

1.11.3.11 Footing Reinforcing

Provide a mat of reinforcing steel (minimum of #5 bars at 12 inch centers each way) in the top of all footings. If calculated loads require larger amounts of reinforcement, the latter controls. Also provide U-bars at 12 inch centers around the periphery of the footing.

Extend spirals at least two inches into the footing. Place the footing top mat immediately below the spiral termination. Place additional spirals below the mat (use a 6 inch spiral gap) down to the vertical bar's point of tangency. Use the same spiral pitch at all locations.

See *Guide Spec. 6.4.7* for footing joint shear reinforcement for Seismic Design Category (SDC) C and D.

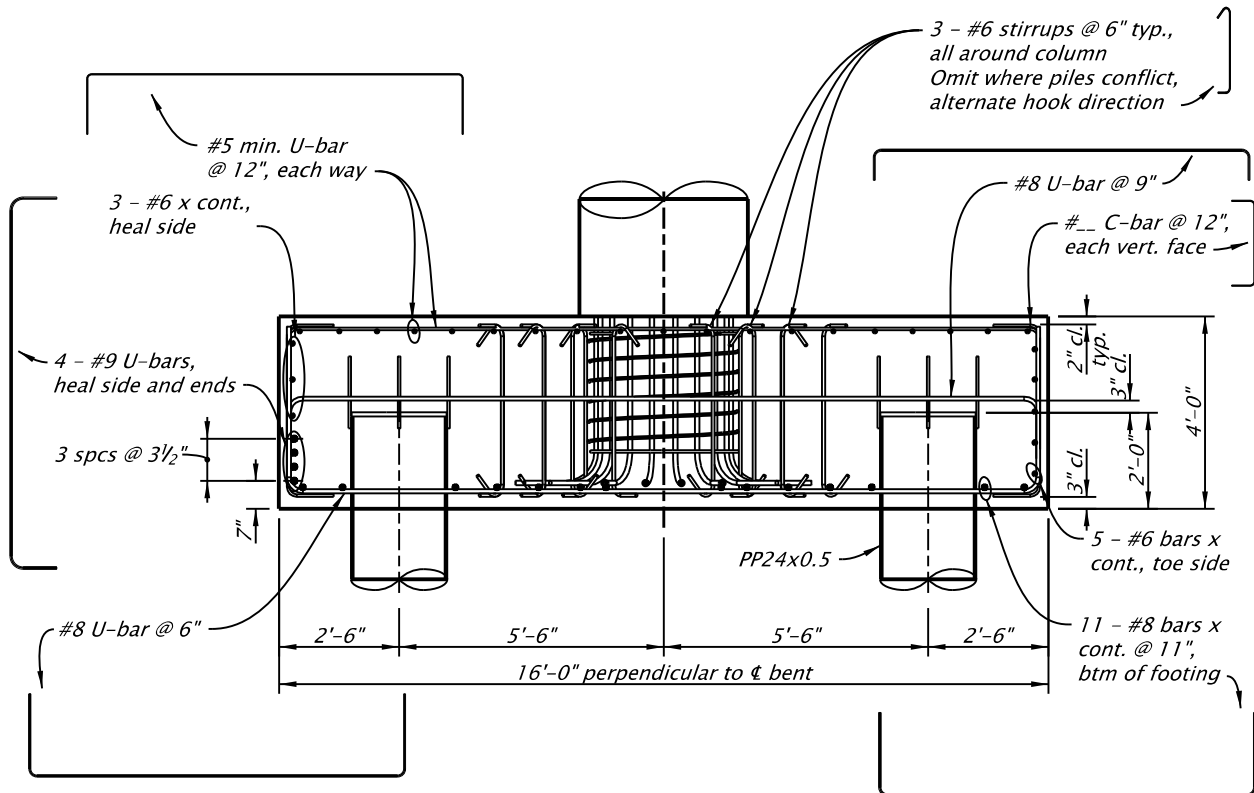

Figure 1.11.3.11A Example of Footing Reinforcing

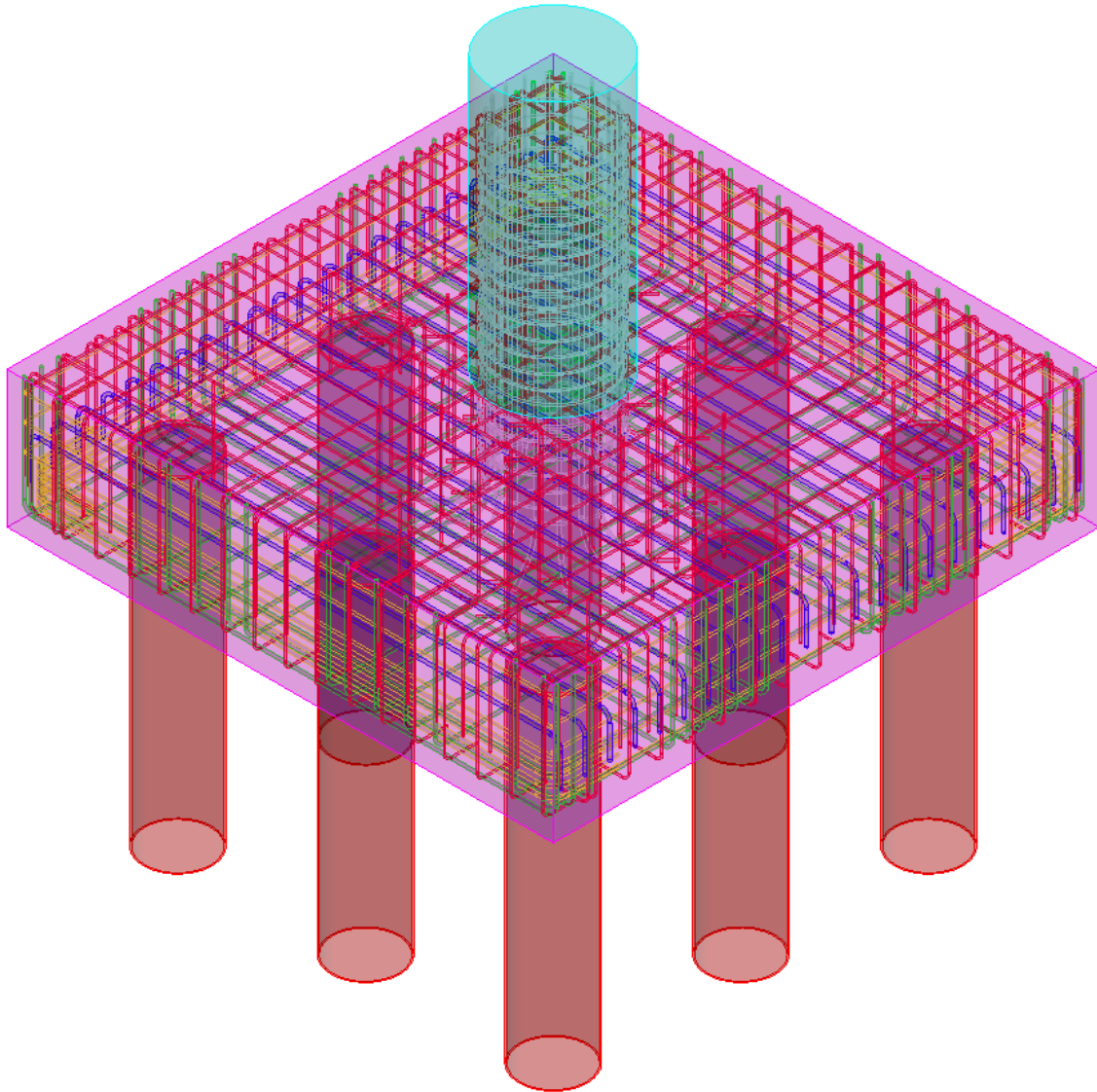

Figure 1.11.3.11A Example of Footing Reinforcing, Isometric View

1.11.3.12 Sloped Footings

General criteria for sloped footing tops are:

- The required footing thickness adjacent to the column should be at least 4'-6". (No minimum edge thickness is specified except as required for shear.)
- The amount of concrete saved should be at least 10 cy.
- The top may be sloped either two ways or four ways, but should not be steeper than 2:1.
- A horizontal area should be provided 6 inches to 12 inches wide outside the base of the column to facilitate forming the column.

1.12 BURIED STRUCTURES

[1.12.1 Culvert Design, General](#)

[1.12.2 Tunnels \(structural elements\)](#)

[1.12.1 Culvert Design, General](#)

Concrete culverts, metal pipe culverts and pipe arches will typically be designed or administered by the Region Tech Centers. Large culverts (diameter or span 6 feet or greater) are processed like bridges. Request a structure number, drawing number(s), etc. for large culverts. A single culvert span, or out-to-out sum of closely spaced culvert spans, of 20 feet or more is defined as a “bridge” and is included in the National Bridge Inventory (NBI). NBI culverts must be load rated per the ODOT Load Rating Manual. Refer to the ODOT Highway Design Manual and Hydraulics Manual for additional guidance.

Precast culverts are designed by the manufacturer according to SP 00595. Ensure that the designs of large culverts comply with the following requirements:

- Precast Elements should consist of individual cells with continuous vertical joints, unless an engineered substructure is provided.
- For precast wingwalls, provide positive connections between wingwalls and RCBC end sections with short closure pours or weldments.
- Provide reinforcement continuity between precast footings and concrete aprons.

The decision of whether to use roadway or bridge railing standards on a culvert is related to both culvert length and fill depth. For culverts under 6 feet in span or diameter, use roadway standards. For culverts between 6 and 20 feet in span, use roadway standards unless the location is considered high risk. Follow the guidance of BDM 1.13.1.8 for guardrail layout in low fill. For NBI culverts, use bridge standards unless fill depth is greater than 2'-8".

[1.12.2 Tunnels \(structural elements\)](#)

(Reserved for future use)

1.13 RAILS, IMPACT ATTENUATORS, AND PROTECTIVE SCREENING

[1.13.1 Bridge Rail](#)

[1.13.2 Bridge Rail Replacement & Retrofit Guidelines](#)

[1.13.3 Impact Attenuators or Crash Cushions](#)

[1.13.4 Protective Screening or Protective Fencing](#)

[1.13.1 Bridge Rail](#)

1.13.1.1 Design Standards

For new and widening projects, use *Section 13* of the current *AASHTO LRFD Bridge Design Specifications* for guidance to determine the required bridge rail. Rails on bridges on interstate routes, major highway routes, and over National Highway System (NHS) routes require a minimum crash test rating of TL-4.

Use 42 inch bridge rail on new bridges and end panels for all interstate routes, major highway routes, and over NHS routes unless special condition apply. Combined with the requirement of MASH, BR290 3'-6" Type "F" Concrete Bridge Rail and BR208 3-Tube Curb Mount Rail in *BDM Table 1.13.1.3B* are the preferred bridge rails. The 42 inch requirement is in accordance with the "Fall Protection – Walking-Working Surfaces" requirements of OSHA.

For bridges on tangent roadways, with an ADTT in one direction less than 1000, speeds below 45mph, and without unfavorable site conditions, bridge rail meeting crash-test rating of TL-3 is acceptable. Unfavorable site conditions include but are not limited to reduced radius of curvature, steep downgrades on curvature, variable cross slopes, and adverse weather conditions.

Also, the structure designer works with the project team to select the best rail for a given site, considering roadway geometry, traffic volume, speed, truck traffic, accident history, sight distance, occupant risk, aesthetics, maintenance, inspection, cost / benefit and related factors.

FHWA approved rails used by other agencies (DOTs, municipalities, etc.) can be used. Using them requires a design exception. Submit design exception according to *BDM 1.2.2* and supported with the following information:

- Appropriate crash test rating
- Crash test data documentation and conclusions that the rail performed acceptably
- FHWA approval for use (listed on FHWA website or approval letter from owner agency)
- Design calculations showing compliance with *LRFD Chapter 13* criteria

Submit requests for frequently used rails to be added to ODOT's Bridge Rail Standard Drawings.

1.13.1.2 Crash Test Policy

Bridge Railing is designed to contain and redirect errant vehicles. Crash testing of barrier rail is performed to verify the strength of the barrier and to assure that critical failure modes such as vehicular stability (i.e. rollover) and occupant compartment deformation are satisfied.

Since 1989 there has been federally required crash testing of bridge rails. And in August of 1998, the FHWA required all new or replacement rails used on Federally funded NHS-route projects to meet the NHRCP Report 350 Test Level 3 (TL-3) requirements or higher.

Bridge Design Manual – June 2020
Oregon Department of Transportation
Section 1 – Design Standards

A [May 30, 1997 FHWA memo](#) identifies 68 crash-tested bridge rails. It also assigns equivalency ratings that relate previous crash testing to current standards of NCHRP Report 350 test levels. Several ODOT Standard Rails are identified on the list. This memo, FHWA approval letters and crash test reports for ODOT standard rails can be found on the [Bridge Section Standard Drawings website](#). Also, [FHWA's Bridge Rail website](#) has a complete list of current crash tested approved rails, associated drawings, supporting crash test reports and acceptance letters.

The January 7, 2016 memorandum from Thomas Everett on the subject of "[AASHTO/FHWA Joint Implementation Agreement for Manual for Assessing Safety Hardware \(MASH\)](#)" discusses the agreement between AASHTO and FHWA that requires all new installations of safety hardware on the NHS to be evaluated using the [2016 edition of MASH](#). The requirement applies to bridge railings with contract letting dates after December 31, 2019.

A list of crash tested barriers can be found through the FHWA website at:
https://safety.fhwa.dot.gov/roadway_dept/countermeasures/reduce_crash_severity/listing.cfm?code=long

The AASHTO Manual for Assessing Safety Hardware (MASH) defines six crash-test levels for evaluation of bridge railing for vehicular traffic, as follows.

Crash Tests Required by AASHTO Manual for Assessing Safety Hardware (2009)

Test Level (TL)	Test No.	Vehicle	Impact Speed	Impact Angle
TL-1	1-10	2420-lb. small car	31 mph	25 degrees
	1-11	4409-lb. pickup truck	31 mph	25 degrees
TL-2	2-10	2420-lb passenger car	44 mph	25 degrees
	2-11	5000-lb pickup truck	44 mph	25 degrees
TL-3	3-10	2420-lb passenger car	62 mph	25 degrees
	3-11	5000-lb pickup truck	62 mph	25 degrees
TL-4	4-10	2420-lb passenger car	62 mph	25 degrees
	4-11	5000-lb pickup truck	62 mph	25 degrees
	4-12	22,000-lb single unit truck	56 mph	15 degrees
TL-5	5-10	2420-lb passenger car	62 mph	25 degrees
	5-11	5000-lb pickup truck	62 mph	25 degrees
	5-12	79,300-lb tractor van trailer	50 mph	15 degrees
TL-6	6-10	2420-lb passenger car	62 mph	25 degrees
	6-11	5000-lb pickup truck	62 mph	25 degrees
	6-12	79,300-lb tractor tank trailer	50 mph	15 degrees

Table 1.13.1.2A

Bridge Design Manual – June 2020
Oregon Department of Transportation
Section 1 – Design Standards

Crash Tests Required by NCHRP Report 350

Test Level (TL)	Test No.	Vehicle	Impact Speed	Impact Angle
TL-1	1-10	2420-lb. small car	31 mph	25 degrees
	1-11	4409-lb. pickup truck	31 mph	25 degrees
TL-2	2-10	2420-lb passenger car	44 mph	25 degrees
	2-11	5000-lb pickup truck	44 mph	25 degrees
TL-3	3-10	2420-lb passenger car	62 mph	25 degrees
	3-11	5000-lb pickup truck	62 mph	25 degrees
TL-4	4-10	2420-lb passenger car	62 mph	25 degrees
	4-11	5000-lb pickup truck	62 mph	25 degrees
	4-12	22,000-lb single unit truck	56 mph	15 degrees
TL-5	5-10	2420-lb passenger car	62 mph	25 degrees
	5-11	5000-lb pickup truck	62 mph	25 degrees
	5-12	79,300-lb tractor van trailer	50 mph	15 degrees
TL-6	6-10	2420-lb passenger car	62 mph	25 degrees
	6-11	5000-lb pickup truck	62 mph	25 degrees
	6-12	79,300-lb tractor tank trailer	50 mph	15 degrees

Table 1.13.1.2B

When crash testing requirements are not met, a Design Exception is required for use of the bridge rail. Refer to [ODOT's Highway Design Manual](#) for the Design Exception request process.

Minor changes may be made to ODOT Standard rails in order to meet a specific need. Changes must maintain the rail's crash worthiness and require a design exception, submitted according to [BDM 1.2.2](#).

Occasionally ODOT accepts rails that have not been crash-tested on a case-by-case basis. Generally the following conditions are present when they are considered:

- Must not be on federal-aid projects
- Design speeds are 35 mph or less
- Rail is mounted on back of a raised sidewalk (5 foot minimum width) with a barrier curb (6-8 inch height)
- Rail is structurally adequate based on loading conditions of [LRFD Section 13](#).

Bridge Design Manual – June 2020
Oregon Department of Transportation
Section 1 – Design Standards

1.13.1.3 Vehicular Railing

The following are the current ODOT bridge rail standards:

Drawing No.	Description	Prior Rail Standards		MASH		Requirements for Use
		Crash Tested	Test Level	Crash Tested	Test Level	
BR290	3'-6" Type "F" Concrete Bridge Rail	Yes	TL-5 (1)	No	TL-5 (1)	None
BR291	Transition 3'-6" Conc. Bridge Rail to Guardrail	Yes (2)	TL-3	No	TL-3 (1)	None
BR208	3-Tube Curb Mount Rail	Yes	TL-4	Yes	TL-4	None
BR209	3-Tube Curb Mount Rail Transition	Yes (2)	TL-3	No	TL-3 (1)	None
BR285	Type "F" Concrete Rail Steel Post and Tube Retrofit	No	-	Yes (2)	TL-4 (1)	None
BR200	Concrete Bridge Rail, Type "F"	NCHRP 230	TL-4 (1)	Yes (2)	TL-3	DE for Test Level
BR203	Transition Concrete Bridge Rail to Guardrail	Yes (2)	TL-4 (1)	No	-	DE for Crash Test
BR206	2-Tube Curb Mount Rail (2)	Yes	TL-4	No	-	DE for Both
BR207	2-Tube Curb Mount Rail Transition	Yes	TL-4	No	-	DE for Crash Test
BR214	Concrete Parapet with Steel Post	Yes	TL-4	No	-	DE for Crash Test
BR216	Sidewalk Mounted Combination Bridge Rail	NCHRP 230	TL-4 (1)	No	-	DE for Crash Test
BR220	Flush Mounted Combination Bridge Rail	NCHRP 230	TL-4 (1)	No	-	DE for Crash Test
BR221	32" Vertical Concrete Parapet	NCHRP 230	TL-4 (1)	No	-	DE for Both
BR226	2-Tube Side Mount Rail (3)	NCHRP 230	TL-4 (1)	No	-	DE for Both
BR230	2-Tube Side Mount Rail Transition	Yes (2)	TL-4 (1)	No	-	DE for Crash Test
BR233	Side-Mounted Thrie Beam Rail and Transition (3)	NCHRP 230	TL-2 (1)	No	-	DE for Both
BR236	Trailing End Bridge Connection Concrete	Yes (2)	TL-3 (1)	No	-	DE for Crash Test
BR263	Conc. Median Barrier at Br. Exp. Joints (Type "F")	No	TL-4 (1)	No	-	DE for Both
BR266	Modified Type 2A Rail	NCHRP 230	TL-2 (1)	No	-	Check with Standards
BR250	Pedestrian Rail on Sidewalk Mounted Conc. Parapet	No (4)	TL-2 (1)	No	-	DE for Both
BR253	Sdwk. Mounted Conc. Parapet w/Chain Link Fencing	No (4)	TL-2 (1)	No	-	DE for Both
BR256	Pedestrian Rail on Type "F" Concrete Bridge Rail	Yes (2)	TL-4 (1)	No	-	DE for Both
BR260	Chain Link Fencing on Type "F" Concrete Bridge Rail	Yes (2)	TL-4 (1)	No	-	DE for Both

Table 1.13.1.3A

Footnotes for Standard Rail [Table 1.13.1.3A](#):

- (1) Evaluated
- (2) Similar to a rail or transition that has been tested.
- (3) These rails can easily be used with precast slabs.

(4) These combination rails are different than what was crash-tested. A 24 inch vertical concrete parapet with a single horizontal steel rail on top was successfully crash-tested at the back of a curbed sidewalk. Although these combination rails are different, it is believed they will perform adequately. They may be used when the design speed is 35 mph or less. For design speeds greater than 35 mph, FHWA approval is on a case-by-case basis.

- DE for Test Level means that a design exception must be submitted according to BDM 1.2.2 that documents the reason why a Test Level 4 bridge rail is not required for this location. Follow the guidance of BDM 1.13.2.1 for criteria.
- DE for Crash Test means that a design exception must be submitted according to BDM 1.2.2 that documents the equivalency of the subject bridge rail to a crash tested bridge rail. NCHRP Report 22-12(03) provides guidance for these evaluations.
- General – Consider maintenance and inspection needs when selecting a bridge rail. Personnel working near a rail shorter than 39 inches are required to tie off for fall protection. Standard [BR200](#) Type “F” rail has transverse holes for this purpose. A 42 inch high rail requires no tie off provisions.

When architectural treatments are used, the minimum concrete cover requirements must be maintained. Cover can be increased to accommodate formliner patterns.

Orient bridge rail and posts normal to grade in the longitudinal direction and vertical in the transverse direction for ease of construction and aesthetics. When deck superelevations exceed 8%, consideration can be given to orienting posts normal to grade in both directions to be more aesthetically pleasing. Apply any modifications to all rail components so they are all oriented the same (i.e. concrete parapet and attachments).

- Joints in Rails – See [BDM 1.13.1.9](#).

Commentary:

- *3’-6” Type “F” Rail ([BR290](#)) - ODOT standard rail [BR290](#) meets PL-3 ([NCHRP 350 TL-5](#)) [crash test requirements](#). Consider TL-5 rated rails for use on medians, curves and roads with heavy truck traffic when there is concern for cross over collisions, truck rollovers and roadway departures. However, geometric improvements to improve safety conditions are preferred rather than relying on a traffic barrier to reduce the severity of a crash. Refer to the [AASHTO Roadside Design Guide](#), Section 5.3 and the [2010 FHWA memo](#) for additional guidance.*
- *Three Tube Curb Mounted Rails ([BR208](#)) – This rail can be used instead of the Type “F” rail when “see-through” is desired. The anchorage details can be modified to accommodate pre-cast slab and box voids, see [DET3205](#). In cooperation with Alaska DOT, crash testing to qualify these rails to the NCHRP 350 TL-4 level was completed in 2001 for the [Three-Tube rail](#).*
- *Standard Concrete Type “F” Bridge Rail ([BR200](#)) - The Standard Type “F” rail is generally the best performing rail. It is generally used where there is high-speed, high-volume traffic, where the structure is on a curve and generally on all interstate and State highways. It is also the preferred rail to be used between a sidewalk and*

Bridge Design Manual – June 2020
Oregon Department of Transportation
Section 1 – Design Standards

traffic when the design speed is greater than 40 mph. Check interference with sight distance from interchange ramps or crossroads. Avoid concrete rail in areas where drifting snow might create a problem. Tubular railing may be preferred in scenic areas where concrete rail would otherwise be indicated. Crash testing to qualify this rail to the PL-2 level was completed in 1997 per [FHWA-RD-93-058](#). It was assigned NCHRP 350 TL-4 equivalency in [FHWA Memo dated May 30, 1997](#).

- *Two Tube Curb Mounted Rails (BR206) – This rail can be used instead of the Type "F" rail when "see-through" is desired. The anchorage details can be modified to accommodate pre-cast slab and box voids, see [DET3205](#). However use of [BR226](#) or [BR233](#) is preferred in these cases. Even though these rails are acceptable in most applications, a Type "F" rail is recommended on high speed and limited access highways. The Type "F" rail is better at redirecting errant vehicles and requires less maintenance. In cooperation with Alaska DOT, crash testing to qualify these rails to the NCHRP 350 TL-4 level was completed in 1998 for the [Two-Tube](#).*

Prior to 1998 Oregon Two-tube curb mount rails are listed as NCHRP 350 TL-2 in the May 1997 FHWA Memo "Equivalent Test Levels for Crash Tested Bridge Railings". This includes standard drawings [43497](#) and early metric [BR206](#), which have tubes with 3/16 inch wall thickness. In a NCHRP 350 TL-2 environment, existing rails from these standard drawings could remain in place without a design exception (they may need maintenance such as re-galvanizing, etc.).

- *42" Single-Slope Concrete Barrier – California and Texas have developed single slope barrier that perform comparably to the Type "F" rail. Both have a NCHRP 350 TL-4 rating but California's detail is preferred as it has better post-crash trajectories. They can be used on selected Federal-aid projects as directed by the Regions. It is acceptable as either a median or shoulder barrier. If a project has this type of shoulder barrier on the roadway, consider using a single slope matching rail on the structure. Using a 42 inch Type "F" rail is preferred instead of the single slope barrier.*
- *Standard Thrie Beam Rail (BR233) - The last steel post may need to be side mounted on to a thickened section of the end panel to accommodate the 3'-1-1/2" space between the last steel rail post and the first timber post in the transition. If end panels are not used, the end bent or wingwalls may need to be extended or adjusted to accommodate the last side-mounted steel post. A scaled-down version of the side-mounted rail was successfully [crash-tested](#) to the NCHRP 230 & 1989 Guide Specifications TL-2 level. ODOT's rail has FHWA approval because it was shown analytically to react as the crash tested version.*
- *Modified Type 2A Rail (BR266) - This guardrail is intended for mounting on a concrete slab on top of RCBC when the fill height is less than the standard post embedment and when spanning the box is not possible (see [BDM Figure 1.13.1.8](#)).*
- *Timber Rail - Timber is generally not used for longitudinal members for either temporary or permanent railing. When a timber rail is desired for architectural reasons (as in a park), a steel-backed timber rail may be acceptable. A glued laminated timber rail has been successfully crash-tested for PL-1 (equivalent to NCHRP 350 TL-2) criteria.*
- *Aesthetic Rails designed by another agency – For certain projects, aesthetic bridge rails are desired which are not found in the list of ODOT standard rails. Alternate rails may be proposed and used with an approved design exception. The design engineer will have to generate and stamp the rail drawing.*

1.13.1.4 Loads

LRFD rail design capacities have been calculated and are on the [ODOT Bridge Engineering website – Software Tools for Design](#) for use when designing deck overhangs.

The design approach for deck overhang supporting concrete parapet railings, as described in *LRFD A13.4.2*, is that the vehicular-collision loads are not specified and that the overhangs are designed for the maximum inelastic force effects which can be generated and transmitted by the railing resisting the vehicular impact. Designing the overhang for full railing resistance will result in an extremely conservative deck overhang that is not in accordance with observed field behaviors. Accordingly, for Design Case 1, design the deck overhang to resist the lesser of a vehicular impact moment, M_{CT} , and coincidental axial tension force, T_{CT} , calculated as follows, for the end and wall conditions:

$$M_{CT,end} = \frac{1.25 \times F_t \times H_e}{L_{c,end} + H_e + X} \quad \text{and} \quad T_{CT,end} = \frac{1.25 \times F_t}{L_{c,end} + H_e + X}$$

$$M_{CT,wall} = \frac{1.25 \times F_t \times H_e}{L_c + 2H_e + 2X} \quad \text{and} \quad T_{CT,wall} = \frac{1.25 \times F_t}{L_c + 2H_e + 2X}$$

Where:

F_t = Transverse force specified in table below for MASH TL-4 impact load for different barrier heights (kips). Design the deck overhang for a collision force of 25% greater than the nominal demand, to account for uncertainties in the load and mechanisms of failure and to provide an adequate safety margin.

Design Forces and Designations	Barrier Height (in.)		
	36	39	42
F_t Transverse (kip)	67.2	72.3	79.1
F_L Longitudinal (kip)	21.6	23.6	26.8
F_v Vertical (kip)	37.8	32.7	22
L_t and L_L (ft.)	4	5	5
H_e (in.)	25.1	28.7	30.2

H_e = Effective height of the vehicle rollover force (ft.)

L_c = Critical length of yield line failure pattern (ft.)

X = Lateral distance from toe of barrier to deck design section (ft.)

The end condition, which occurs at bridge ends and expansion joints, will control design due to the limited distribution length. On retrofit projects, when the overhang has capacity for the wall condition, strengthening of overhangs may be limited to $(L_c + H_e + X)$ from the end locations. When overhang capacity is within 60% of demand on an existing bridge deck, contact the Bridge Rail Standards Engineer prior to designing strengthening. Additional reductions in demand may be available based on ongoing research.

Using the calculated parapet resistance, M_c and T , of the parapet at its base per *LRFD A13.4.2*. LRFD rail design capacities will give overly conservative results in most cases. Only use these loads for locations that are not TL-4.

For new bridges, design the overhang for a minimum of TL-4 in all cases in order minimize the need for future strengthening.

Commentary:

LRFD CA13.4.2 states, the crash testing program is oriented toward survival and not necessarily the identification of the ultimate strength of the railing system. This could produce a railing system that is significantly over-designed, leading to the possibility that the deck overhang is also over-designed.

Based on observations of impacted bridge railings from crash testing, an overhang designed with typical deck reinforcing of #5 at 6 in shows the desired behavior that the deck overhang does not fail if a railing failure occurs due to a collision. See TTI Test Report No. 9-1002-5, Figures 3.1-3.3, 6.3 and 6.4.

Caltrans, INDOT and Ohio DOT are using a similar approach. In addition, the ongoing research of a W-shape failure mode to replace the yield line failure mode indicates a larger distribution length for the flexural demand for a deck overhang. This will further reduce the design moment for deck overhang beyond this proposed change.

Per TTI Test Report No. 9-1002-5, the requirement of 36 in rail height is to overcome the rollover of the truck but not strength of the railing system. The impact load calculated using LS-DYNA show the moment demand for the 32 in and 36 in rails are similar. The additional 6 in increase in rail height to 42 in is in accordance with the “Fall Protection – Walking-Working Surfaces” requirements of OSHA.

• Strength

Test Level	NCHRP 350 ^a			MASH		
	Lateral Impact Force (kips)	Resultant Force Height (in)	Moment (kip-in)	Lateral Impact Force (kips)	Resultant Force Height (in)	Moment (kip-in)
TL-3	54	24	1296	71	19.5	1385
TL-4	54	32	1728	68 ^b	25 ^b	1700

^a AASHTO LRFD Bridge Design Specifications, Section 13
^b Impact force and resulting height corresponds to 36 in tall barrier

The effort to define design impact loads for MASH TL-4 was reproduced and expanded under from NCHRP Project 22-20(02) to NCHRP20-07(395) reports. Researchers used finite element impact simulations to determine the magnitude and distribution of impact loads imparted by the SUT (Single Unit Truck) based on MASH TL-4 impact conditions. It was found that the magnitude, distribution and resultant height of the impact load are influenced by the height of the barrier. Design impact loads in the lateral, longitudinal, and vertical direction, and the longitudinal distribution and height of the resultant lateral load were recommended for MASH TL-4 impacts.

References:

1. TTI Test Report No. 9-1002-5: Determination of Minimum Height and Lateral Design Load for MASH Test Level 4 Bridge Rails
https://texashistory.unt.edu/ark:/67531/metaph326629/m2/1/high_res_d/txca-0111.pdf
2. NCHRP22-14(03) Volume I: Evaluation of Existing Roadside Safety Hardware Using Updated Criteria— Technical Report
<http://www.trb.org/Publications/Blurbs/163969.aspx>
3. NCHRP22-20(02): Design Guidelines for TL-3 through TL-5 Roadside Barrier Systems Placed on Mechanically Stabilized Earth (MSE) Retaining Walls
<http://apps.trb.org/cmsfeed/TRBNetProjectDisplay.asp?ProjectID=2735>

4. *NCHRP20-07(395): MASH Equivalency of NCHRP Report 350-Approved Bridge Railings*
[http://onlinepubs.trb.org/onlinepubs/nchrp/docs/NCHRP20-07\(395\)_FR.pdf](http://onlinepubs.trb.org/onlinepubs/nchrp/docs/NCHRP20-07(395)_FR.pdf)
5. *Caltrans, INDOT and Ohio DOT are using a similar approach.*
 - a. *CALTRANS – Page 3, <https://dot.ca.gov/-/media/dot-media/programs/engineering/documents/caamendments/201907-section13-railings-a11y.pdf>*
 - b. *INDOT – Page 17-18, https://www.in.gov/indot/design_manual/files/Ch404_2013.pdf*
 - c. *Ohio DOT – Page 411-412, http://www.dot.state.oh.us/Divisions/Engineering/Structures/standard/Bridges/BDM/BDM2007_07-20-18.pdf*

1.13.1.5 Bicycle and Pedestrian Railing

Use bicycle and pedestrian railing on the outside of structures that are specifically designed to carry bicycle and/or pedestrian traffic. Separate bicycle and pedestrian traffic from vehicular traffic by a vehicle rail when design speeds exceed 40 mph.

AASHTO and the [Oregon Bicycle and Pedestrian Plan](#) require a minimum height of 42 inch for either bicycle or pedestrian railings. The Standard Protective Fencing (**BR240**) and Standard Pedestrian Rail (**BR246**) meet this requirement. At locations with high bicyclist traffic, rail height can be increased up to 54 inches.

Use curbs (preferably 6 inch, max. 8 inch) above the level of the sidewalk under all pedestrian railings where there will be significant pedestrian, vehicular or boat traffic under the structure. Use 8 inch curbs only where design speeds are 45 mph or less. Do not use a curb unless the bridge rail was crash tested with a curb. Runoff from sidewalks does not need to be carried off of a structure, see **BDM 1.24.5** for additional guidance.

1.13.1.6 Combination Rails

Combination rails are rails that provide protection to both vehicles and bicycles or vehicles and pedestrians. When design speeds exceed 40 mph, provide a vehicle rail at the traffic face of the sidewalk.

Neither AASHTO nor FHWA have clear specifications concerning acceptance criteria for combination rails. The following recommendations should provide reasonable safe protection:

- Crash-test combination rail to the performance level requirements of the site. Exceptions to crash testing may be allowed in certain situations as stated in **BDM 1.13.1.2**.
- Combination rails must not have any opening such that a 6 inch sphere can pass through any opening to a height of 27 inches. Above 27 inches, an 8 inch sphere must not pass through. See **LRFD 13.8.1**.
- Combination rails on the back of sidewalks for pedestrians or bicycles must be at least 42 inches high. Determine these rails on a case-by-case basis depending on bicycle/pedestrian use.
- Combination rails must be at least 42 inches high (and in some cases 54 inches) where bicycles share the shoulder. Determine these rails on a case-by-case basis depending on site location and bicycle use.

Available combination sidewalk/traffic rail:

- Standard Drawings **BR250** and **BR253** - These provide a 32 inch high vertical face concrete parapet with pedestrian rail or chain link fence on top at the back of a raised sidewalk (54 and 56

inch rail heights). A similar configuration was crash-tested, and although it is believed they will perform adequately, use them only on a case-by-case basis in locations behind a raised sidewalk at least 5 feet wide where the design speed is 35 mph or less. For design speeds greater than 35 mph, FHWA approval is on a case-by-case basis.

- Standard Drawings BR216 – These provide a single tube or two-tube mounted on a 31 inch vertical parapet (42.5 and 54 inch rail height respectively). The single tube rail has been [crash tested to PL-2 \(equivalent to NCHRP 350 TL-4\)](#) requirements. It is believed the two-tube rail will perform adequately and further testing (with the additional top rail) is not warranted.

Available combination bicycle/traffic rail:

- Standard Drawings BR256 and BR260 - These are Type "F" concrete rail with pedestrian rail or chain link fence on top (54 and 56 inch rail heights). The Type "F" concrete rail has been crash tested to PL-2 (equivalent to NCHRP 350 TL-4) requirements. These combination rails were developed to be used next to a bike lane/shoulder combination.
- Standard Drawing BR240- This combines a Type "F" concrete rail, and a two-tube rail with a protective fence mounted behind it (see BR240 details Type 'C' and Type 'D', respectively). The Type "F" concrete rail has been crash tested to PL-2 (equivalent to NCHRP 350 TL-4) requirements. The two-tube rail has been tested at the NCHRP 350 TL-4 level.
- Standard Drawings BR220 – Single-tube or two-tube rail mounted on a 31 inch vertical parapet (42.5 or 54 inch rail height respectively). The single-tube rail has been [crash-tested to PL-2 \(equivalent to NCHRP 350 TL-4\)](#) requirements.

1.13.1.7 Rail Transitions

Rail transitions are required on rail installations to provide a controlled variation in stiffness from the approach guard rail to the more rigid bridge rail. BDM 1.13.2.2(b) provides guidance on treatment of rail transitions on existing bridges.

The current transitions are crash tested and have very close post spacing. Problems have arisen when the first post off the structure conflicts with the bridge end. In some cases the first post was omitted, which is not acceptable. This has happened when the installation was left totally to the contractor, without advance guidance from the Engineer.

Consider any post conflicts and detail a solution in the contract plans. Possible remedies include:

- Remove concrete to allow room for the normal post to fit.
- Add a concrete pad (with anchor bolts) to the existing concrete, and add a base plate to the first post. This will require drilling into the existing rail or curb to install dowel bars for anchorage.
- Mount a structural steel spacer block to a vertical face of a rail end block, in place of a post.

1.13.1.8 Rails Over Low Fill Culverts

Standard Drawing BR266, Modified Type 2A Rail, is for use when the fill height above a box culvert or rigid frame is less than the standard embedment of timber guardrail posts. This design is the same as the system which was reported in the [Transportation Research Record No. 1198](#). During the test, the steel posts yielded about 32 inches, which is similar to ODOT's timber post system. Using this method eliminates the need for transitions, which are required because the steel post bridge rail is normally a rigid connection. The crash test report claims this system is acceptable for fill heights from 0 to 3 feet.

For culverts under 18 feet, one or two posts can now be eliminated from a normal W-beam guardrail installation (post spacing at 6'-3") by using two nested W-beam elements (see *BDM Figure 1.13.1.8* below). This design has been successfully crash-tested and can now be used on Federal-aid projects.

BDM Figure 1.13.1.8 - Detail A, shown below, is an acceptable method for continuing guardrail over areas where a 12'-6" guardrail span, that contains no posts, is necessary. *BDM Figure 1.13.1.8 - Detail B*, shown below, is an acceptable method for continuing guardrail over areas where an 18'-9" guardrail span, that contains no posts, is necessary. See *RD470*.

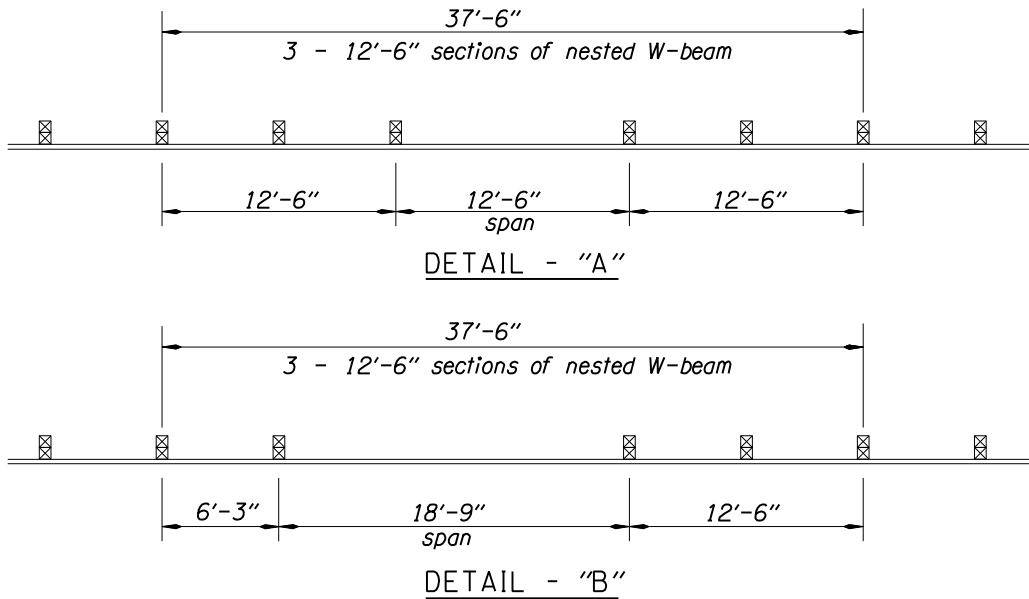

Figure 1.13.1.8

1.13.1.9 Joints in Bridge Rail

Concrete bridge rails are usually constructed vertical, or plumb, and not normal or perpendicular to the deck. Joints and architectural treatments should also be constructed or placed plumb.

Type 'B' Joints (at Interior Bents with Continuous Deck) – The ¼ inch preformed expansion joint filler through the rail forms a joint which is provided to reduce shrinkage cracks in the rail and reduce the tendency of the rail to act compositely with the superstructure.

Scoring Joints – Place at 15 foot maximum centers, equally spaced between Type 'B' joints and expansion joints. For typical ODOT standard concrete rails, space joints in the range of 10 to 15 feet. The joint spacing must equal or exceed the critical length "Lc" of the yield line failure pattern (see *LRFD A13.3.1*) for a vehicle impact within a wall segment (typically in the range of about 8.5 to 12.5 feet). Show the location of each joint on the deck plan, but they need not be dimensioned. The bottom two longitudinal bars are continuous through scoring joints but terminate 2 inches before all other joint types.

At Bridge Deck Expansion Joints – Provide rail joints at every structure joint to prevent cracking or spalling of the rail or structure. Show rail details at expansion joints on the standard drawings. Skew rail joints to match the deck joint for skew angles up to 20 degrees. For skew angles in excess of 20 degrees, orient the rail joint normal to the rail. See *BR139* for details.

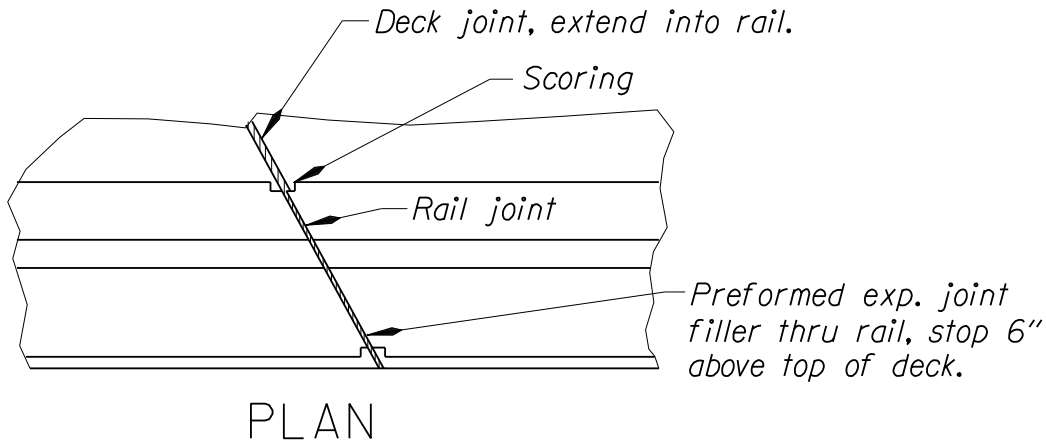

Figure 1.13.1.9A

Do not leave rail joints as open joints, including joints between the bridge end and the bridge end panel, because of the potential problem of water passing through the joint and eroding the embankment. Use the same joint material in the rail or curb as used in the roadway. If an asphaltic plug joint is used, a non-sag poured joint seal or compression joint seal could be used in the rail or curb.

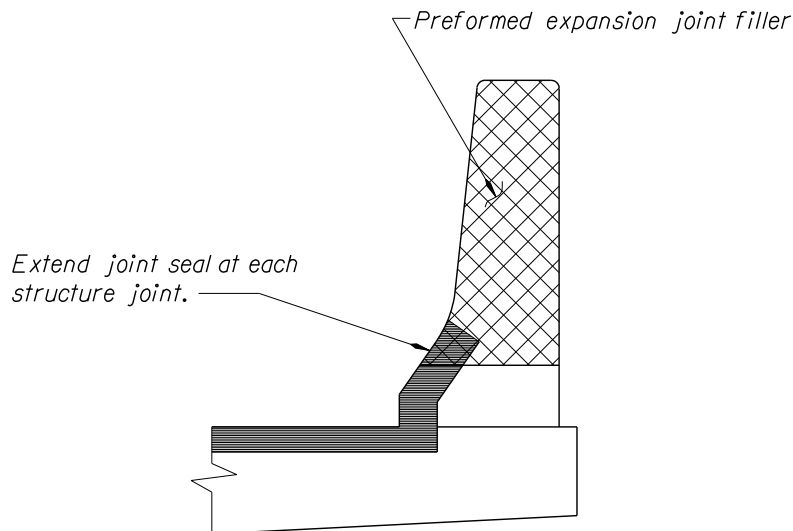

Figure 1.13.1.9B

1.13.1.10 Temporary Barriers

FHWA requires that temporary bridge rails meet TL-3 performance criteria using successfully crash tested systems. Ordinarily temporary bridge rail is constructed from pin and loop median barrier secured against sliding and overturning as shown in Standard Details [DET3295](#) and [DET3296](#). Restraints will not be required if the barrier can be displaced 3 feet or more away from the traffic side(s) without infringing on a traffic lane, a work area, or beyond the edge of the deck. Check with the Traffic Control Plans designer to determine if reflectorized barrier should be noted on the detail plans.

The ODOT anchored barrier is adapted from barrier used in a Lincoln, Nebraska crash test, documented in report [TRP-03-134-03](#) dated August 22, 2003. The goal was to model and develop a barrier having

shallower anchors than were used in the crash test, so they could be bonded into typical bridge decks. First, models were run of the crash test barrier to build confidence in the analysis relative to the known testing results. New models were run having 4 or more anchors. In addition to the barrier's own anchors, the system relies on the pin and loop connections to transfer load resistance from adjacent barrier segments. To determine maximum anchor loading, one cannot simply divide the total applied load by the number of anchors. Due to barrier deflection, anchors nearest the loading zone will receive a much higher fraction of the load than those further away. A 3-D finite element model is needed to get a realistic estimate of anchor loads. Support spring constants can be calculated from axial and bending deflections of the exposed anchors themselves, which will aid in distributing reactions to other anchors thus reducing peak loads. Provisions of *BDM 1.20.2.2* were used to estimate resistance of resin bonded anchors for LRFD loads.

Bridge Decks Overhangs: Check structural capacity of existing bridge decks overhangs as some existing bridge decks overhangs may be overstressed due to a rail impact loads.

Anchor Bolts, Nuts and Washers: Resin bonded anchor bolts with fully threaded rods in accordance with ASTM F1554 Grade 36. Use anchor bolts for through bolting in accordance with ASTM A307 or ASTM F1554 Grade 36. Use nuts in accordance with ASTM A563 or ASTM A194. Use flat washers in accordance with ASTM F436 and plate washers shall be in accordance with ASTM A36 or ASTM A709 Grade 36.

Install four (4) anchor bolts per barrier on the traffic side as shown in Standard Details *DET3295* and *DET3296*. Do not drill into or otherwise damage the tops of supporting beams or girders, bridge deck expansion joints or drains. Install anchor bolts and nuts so that the maximum extension beyond the face of the barrier units is ½ inch. Snug tighten the nuts on the anchor bolts. For through bolted installations, snug tighten the double nuts on the underside of the deck against each other to minimize the potential for loosening.

Omit one (1) anchor bolt within a single barrier unit if a conflict exists between the anchor bolt location and a bridge deck expansion joint or drain. The adjacent barrier units must each be installed with the standard four (4) anchor bolts.

Removal of Anchor Bolts: Upon removal or relocation of barrier units, remove all anchor bolts and completely fill the remaining holes in bridge decks and approach slabs with an approved patching material from the QPL. If ACWS overlay is present and is to remain, completely fill the remaining holes with hot or cold patch asphalt material.

Other Rail Options: At least one crash tested proprietary steel safety shape rail system exists, which could be a contractor option for temporary rail use. Example: see [FHWA Acceptance Letter B-165](#).

1.13.2 Bridge Rail Replacement & Retrofit Guidelines

1.13.2.1 Design Standards

ODOT promotes highway planning that replaces or upgrades railing on existing bridges on interstate routes, major highway routes, and over National Highway System (NHS) routes to minimum crash test rating of TL-4. Select the transition appropriate for the speed. Speeds of 45 mph and above require a TL-3 transition. Speeds below 45 mph can use a TL-2 or TL-3 transition.

For bridges on tangent roadways, with an ADTT in one direction less than 1000, speeds below 45mph, and without unfavorable site conditions, bridge rail meeting crash-test rating of TL-3 is acceptable. Unfavorable site conditions include but are not limited to reduced radius of curvature, steep downgrades on curvature, variable cross slopes, and adverse weather conditions.

Although AASHTO has not set acceptance criteria for retrofitting existing substandard rails it is recommended that *LRFD Section 13* criteria be used as a starting point. **Stability, geometrics and**

strength review is required for all rail retrofit projects.

Stability relates to all of the characteristics of the barrier that effect vehicle stability, such as barrier height, barrier shape, and barrier stiffness. The **strength** category relates to the barrier's ability (including deck overhang) to effectively contain and redirect the vehicle as well as preventing the vehicle from penetrating through the barrier. *LRFD Section 13* contains procedures for analyzing the structural capacity of different types of bridge railings (e.g., steel, concrete). The **geometric** relationships for bridge railings pertain to the potential for wheel, bumper or hood snagging on elements of the bridge rail system. For each bridge rail system, post setback distance, ratio of contact width to height, and vertical clear opening were determined or calculated and plotted against the current *LRFD Section 13*.

When required (per *BDM 1.13.2.2*) to retrofit or replace rails on 4R, 3R, 1R and preventative maintenance projects on State Highways or NHS roads, provide bridge rails conforming to *BDM 1.13.2.1*.

When required (per *BDM 1.13.2.2*) to retrofit or replace rails on 4R, 3R, 1R and preventative maintenance projects on Local Agency roads, provide bridge rails conforming to the current *LRFD* standards.

Commentary:

FHWA policy is that all new or replacement railing on National Highway System or Interstate Highway System bridges must meet Test Level 3 (TL-3) crash-test criteria at a minimum. However, responsible transportation agencies have limited latitude to define required crash test rating for bridge rails.

Rail selection using site condition, geometry, ADTT, design speed etc. per NCHRP Report 22-12(03) Recommended Guidelines for the Selection of Test Levels 2 through 5 Bridge Railings and NCHRP Report 492 Roadside Safety Analysis Program (RSAP) – Engineer's Manual is acceptable.

References:

1. *ACTION: Crash Testing of Bridge Railings – May 30, 1997*
https://safety.fhwa.dot.gov/roadway_dept/countermeasures/reduce_crash_severity/barriers/bridgerailings/docs/bridge.pdf
2. *Guide Specifications for Bridge Railings, American Association of State Highway and Transportation Officials, Washington, D.C., 1989*
3. *NCHRP Report 492 Roadside Safety Analysis Program (RSAP) – Engineer's Manual*
http://onlinepubs.trb.org/onlinepubs/nchrp/nchrp_rpt_492.pdf
4. *NCHRP Report 22-12(03) Recommended Guidelines for the Selection of Test Levels 2 through 5 Bridge Railings* [http://onlinepubs.trb.org/onlinepubs/nchrp/docs/NCHRP22-12\(03\)_FR.pdf](http://onlinepubs.trb.org/onlinepubs/nchrp/docs/NCHRP22-12(03)_FR.pdf)

1.13.2.2(a) Treatment of Existing Bridge Rails

The following are minimum requirements for treatment of existing rails for various circumstances on state owned bridges. It is always acceptable to exceed these requirements.

Bridge rails on state owned bridges not upgraded under the following criteria are deferred to the [Bridge Rail Prioritization and Retrofit Program](#) (BRPRP). The BRPRP was developed to address bridge rail deficiencies in a more strategic way and to focus funds on rails most in need of replacement or retrofit by deferring work on rails within the limits of a project where a significant safety hazard does not exist. The safety warrants contained in *BDM 1.13.2.2(b)* provide a framework for identifying bridges where a significant safety hazard does not exist and it is appropriate to defer rail work.

In summary the BRPRP Priority List is targeting bridge rails that are made of aluminum and those that have more than 11 points in the prioritization algorithm. These rails will be retrofitted in separate projects that include bridges with high priority rails along a given highway segment.

- a. [Preventive maintenance work](#) does not require a design exception to defer rail replacement or retrofit work when the requirements of [BDM 1.13.2.2\(b\)](#) are met.
- b. For retrofit and replacement on 1R, Roadway funded projects, upgrade rails in accordance with [HDM 1.3.2.5](#).
- c. 3R projects (restoration and rehabilitation) that do not affect the bridge rail and involve no structural work do not require a design exception to defer rail replacement or retrofit work when the requirements of [BDM 1.13.2.2\(b\)](#) are met.
- d. 3R projects (widening and rehabilitation) that affect the bridge rail, involve structural superstructure work, widen the structure, or re-decks (full-depth) any complete span require compliance with MASH or NCHRP 350 crash test requirements.

1.13.2.2(b) Safety Warrants

- a. On preventative maintenance work and 1R projects upgrade transitions when the following blatant safety hazards exist (See [Technical Bulletin RD18-02\(B\)](#)):
 - Approach rail is not attached to the bridge rail
 - Rail ends are blunt and unprotected
- b. On 3R projects, upgrade transitions, approach rail and end treatments to current standards. When no other work is done that affects the bridge rail, rail transitions, approach rail and end treatments may be upgraded without upgrading the bridge rail. Request a Design Exception to leave non-standard bridge rail in place.

On 3R projects, upgrade the rail to conform to [BDM 1.13.2.1](#) when any one of the following safety warrants exists:

- Three or more accidents or a fatality has occurred in the past five years at the bridge site
 - The rail is in a condition state four
 - The rail height is less than 27 inches. Existing rails may be raised to meet height requirements, provided the existing strength capacities are not reduced by the revised configuration.
 - The bridge is located on an Interstate or high-speed, high-volume facility (for this purpose high volume is considered AADT of 30,000 or higher and has shoulder widths of less than 3 feet)
- c. Regardless of project classification, upgrade the rail when a Safety Assessment by the Region Traffic Engineer recommends an upgrade.
 - Consult the Region Traffic Engineer for concurrence when a rail upgrade is being postponed or deferred for 3R work. The Region Traffic Engineer will perform a Safety Assessment to analyze existing safety hazards to determine if the appropriate solution is being implemented. See [HDM 1.3.2.5](#), [5.4.2.1A](#), [6.5.2.1A](#), [7.7.2](#) for additional information on Safety Assessments. Document their concurrence in the TS&L Report.

1.13.2.2(c) Mitigation

Occasionally it may be difficult to upgrade an existing deficient rail with a cost effective crash tested rail. In this case, a "special" retrofit design may be necessary and a Design Exception is required. The "special" retrofit design should try to emulate one (have similar geometric and strength features) as a crash tested rail. Use standard transitions for non-standard retrofits.

1.13.2.2(d) Design Exceptions

Justify design elements not meeting *BDM 1.13.2.1*, *1.13.2.2(b)* and *1.13.2.3* or *LRFD* standards and document them with a design exception as specified in Chapter 14 of the [ODOT HDM – Design Exception Process](#). Some installations may require a Design Exception, such as:

- When the deck cannot support the added load
- When work is being postponed because the bridge is scheduled for widening or replacement in the current STIP
- For other reasons in the public interest.

1.13.2.3 Identifying Deficiencies of Existing Bridge Rails

The most appropriate retrofit option is based on the type of deficiencies present. Upgrading structurally deficient rails requires strengthening the existing rail and perhaps deck overhang. Upgrading functionally obsolete rails requires eliminating undesirable geometric features.

- a. The bridge rail must be strong enough to prevent penetration.** Most rails properly designed after 1964 are strong enough to contain an impacting vehicle while those designed prior to 1964 are typically structurally inadequate. All aluminum tube rails are structurally inadequate.
 - Apply current *LRFD* standards to check structural adequacy of the rail and deck. Determine and provide the capacity/demand ratio for the rail and deck.
 - For historic bridge rail projects, apply current *LRFD* standards to check structural adequacy of the rail and deck. If the rail and deck does not meet the *LRFD* standards, determine the percentage of the LRFD standard load that can be practically achieved.
 - When capacity is not achieved either in the rail or deck, strengthening measures or exceptions may be made based on project type, in particular when the bridge is historic. Obtain a Design Exception whenever rail or deck capacity does not fully meet *LRFD* standards.
- b. The bridge rail must safely redirect errant vehicles.** Geometric features of rails that may produce high deceleration forces or cause a vehicle to roll over after impact are termed functionally obsolete. Although best determined by a crash test, there are four geometric features that can be used to identify an existing rail as acceptable or functionally obsolete without crash testing:
 - Height of Rail. The bridge rail must be high enough not only to prevent the vehicle from vaulting over, but also to prevent the vehicle from rolling over after impact. An existing rail must meet the minimum rail height specified in *LRFD Table A13.2.1* to be adequate. Rail height is measured from the riding surface, or top of sidewalk when present.
 - Presence and Location of Curbs. A curb or sidewalk between the travel lane and the bridge rail may cause an impacting vehicle to launch over the rail or strike it from an unstable position. Rails with curb heights of 6 inches or more and widths of 9 inches or more where speeds are greater than 45 mph are typically deficient.

- Vertical Openings and Post Setback. Rails with large openings or exposed posts may cause snagging. Generally extensions or recessions beyond 2 inches are considered potential snag points. Refer to *LRFD A13.1.1* for guidance to determine if a tube rail is deficient based on opening height and post set back. Nearly all stealth rails are deficient in this regard and will require a Design Exception. The following are examples of deficient rails due to snagging potential from large openings in the rail or exposed posts:
 - concrete parapet with large openings (e.g. *Dwg 3411*)
 - timber rail with concrete posts (e.g. *Dwg 4412 & 4441*)
 - steel rail with concrete posts (e.g. *Dwg 7044*)
 - Rail Continuity. Rails made up of separate unconnected elements may cause a vehicle to be redirected uncontrollably. Rails that are not connected to concrete end posts have weak spots at the discontinuity that may cause snagging. Discontinuities resulting in more than 2 inches of deflection are considered a serious snagging concern.
- c. The bridge must have an adequate approach rail to bridge rail transition.** Like bridge rails, transitions are crash tested to confirm they are structurally and functionally acceptable. To reduce the likelihood of a vehicle snagging, pocketing, or penetrating the transition ensure the following features are present:
- a firm connection to the bridge rail
 - a gradual stiffening of the rail/post system as it approaches the bridge rail
 - a block between the rail element and the post.

In low speed locations (45 mph or less) where approach rail is not used, slope the bridge rail end down or shield it using a crash cushion. See *HDM 4.6.6* for additional guidance.

1.13.2.4 Designer's Checklist

The following is a check list of things to consider for rail retrofit projects:

- a. Determine the project classification (e.g. preventative maintenance, 3R, 3R with bridge rail work, etc.)
- b. Determine the Performance Level requirements
- c. Determine deficiencies of the existing rail and evaluate the most appropriate replacement and retrofit options per *BDM 1.13.2.1 and 1.13.2.3*.
- d. Examine the safety warrants described in *BDM 1.13.2.2(b)*.
- e. Check Structural Capacity of Existing Bridge - Some existing bridge decks (i.e. overhangs) may be overstressed due to a rail impact loads. In those cases, analyze the feasibility and cost of deck strengthening. If this appears to be unfeasible, request a Design Exception to leave non-standard bridge rail in place. Check for structural reinforcing in the existing rail, specifically in negative moment regions.
- f. Where applicable, use one of the Standard Retrofit Drawings (see *BDM Table 1.13.2.4*). Where it is not feasible to use a Standard Drawing, use a crash tested rail or a rail that emulates one and request a Design Exception.
- g. Estimate Cost.
- h. If a design exception is required, provide documentation according to *BDM 1.13.2.2(d)*.

Consider the following aspects of the project in the selection of a retrofit railing when planning for a bridge that will be widened or rehabilitated:

Elements of the bridge structure

- Review details of the deck and curb reinforcement of the existing bridge to determine if the deck edge is capable of being retrofitted with an adequate new railing. Note in particular:
 - Deck thickness and overhang width;
 - Curb width and height and reinforcement; and
 - End rail section related to joint and end bent diaphragm.

Characteristics of the bridge and location

- Evaluate details of the location, such as the following:
 - Bridge width, alignment, and grade;
 - Approach roadway's width, alignment, and grade;
 - Position of adjacent streets and their average daily traffic;
 - Posted speed at bridge, average daily traffic, and percentage of truck traffic;
 - Accident history on the bridge.

Features of the retrofit designs

- Carefully review details of potential retrofit designs, such as the following:
 - Placement or spacing of new anchor bolts or dowels;
 - Reinforcement anchorage;
 - Approach guard fence post positioning;
 - Shoulder width required by the new railing;
 - Impact on existing sidewalk width; and
 - Impact to ADA requirements.

STANDARD RETROFIT DETAILS

DRAWING NO.	DESCRIPTION	*CRASH TESTED	PERF. LEVEL
BR270	Rail Transition From Thrie Beam to Curb and Parapet Rail	NCHRP 230 & 1989 Guide Spec.	PL-2 (equivalent to NCHRP 350 TL-4)
BR273	Thrie Beam Rail Retrofit For Curb and Parapet Rail Connection Details	NCHRP 230 & 1989 Guide Spec.	PL-2 (equivalent to NCHRP 350 TL-4)

* Crash tested or similar to a rail that has been crash tested (only the rail, not the anchor connection or the entire rail system). Check Structural Capacity of the existing bridge decks overhangs.

Table 1.13.2.4

Note that Standard Drawing BR276, BR280, BR283 and BR286 have been discontinued and moved to Standard Details *DET3276*, *DET3280*, *DET3283* and *DET3286*. The anchor connection for *DET3280* and *DET3283* were designed to the 10 kip horizontal load per the AASHTO Standard Specifications for Highway Bridges, 17th Edition or earlier. Design the anchor connection to meet the current *LRFD* standards and obtain a Design Exception due to the lack of MASH testing of this detail.

1.13.3 Impact Attenuators or Crash Cushions

1.13.3.1 Attenuator Design

Attenuators are required in areas, such as gore points of diverging roadways and columns in medians, where hazardous objects cannot be removed from the possible paths of vehicles.

The need for attenuators can often be eliminated by omitting or removing hazardous objects from gore areas. Non-breakaway sign supports are examples of such objects. Bridge parapets in gore areas may be avoidable when they occur near the end of a bridge, where their need can be eliminated by bridging the space between diverging roadways.

Space in a gore area is valuable as a recovery or evasive maneuver area. Therefore, always remove space wasting features such as curbs and raised pavements. This will avoid interference with the proper functioning of the crash attenuator and it can be located as far from the gore nose as possible.

Bridge will provide designs and plans for attenuators located on structures. Roadway will provide designs and plans for other locations.

Utilize attenuators that have passed NCHRP 350 testing on new project designs.

1.13.3.2 Chevrons

Reflective chevrons are detailed on attenuators to make them highly visible and give direction to traffic. Make sure they are correctly detailed, as shown below, on the plans. Refer to *SP 00940* and normally specify a Type "Y2" sign. Confirm the sign type with the Traffic Control Unit.

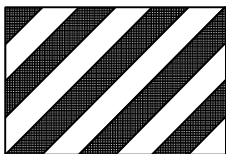

TRAFFIC
TO LEFT ONLY

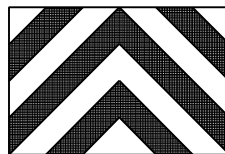

TRAFFIC
EITHER DIRECTION

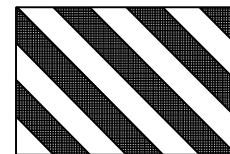

TRAFFIC
TO RIGHT ONLY

Figure 1.13.3

1.13.4 Protective Screening or Protective Fencing

Provide protective screening on overpasses (new or existing) at the following locations:

- All structures crossing freeways (interstates and similar controlled access highways with at least 4 lanes) that carry vehicles and/or pedestrians.
- Structures that have sidewalks and that cross high-speed facilities (posted speed \geq 55 mph) and that are within $\frac{1}{2}$ mile of a school, playground, park, athletic field, shopping center, or other facility likely to generate pedestrian traffic.
- All other structures (with or without sidewalks) crossing high-speed facilities with regular pedestrian traffic.
- Railroad overcrossings.
- Pedestrian structures.

Protective screening need not be provided at the following locations:

- Freeway ramp structures that typically do not have any provisions for pedestrians.
- Where screening creates a sight distance hazard for motorists. However, approval of a design deviation is required. The basis for such a design deviation is discussed below.

1.13.4.1 Protective Screening Design Criteria

Design the protective screening to deter persons from throwing objects from the overpasses onto the freeways. Design protective screening using the following criteria:

- Lightweight (less than 100 plf)
- Translucent (see through)
- Openings 3" square or less (normally a 2 inch chain link mesh is acceptable, with a 1 inch mesh for special cases)
- Minimize projected area (less than 30 percent)
- Difficult to climb (no handrail)
- Able to carry pedestrian rail loading
- No opening between the bottom of screening and top of curb, deck, sidewalk, or concrete bridge rail and ensure the bottom of screening has sufficient stiffness to prevent permanent large deflections
- Minimum 8 feet high (from top of walk surface), except 10 feet high at railroad overcrossings. When ornamental screening has a variable height, ensure minimum height is maintained at all locations that cross over travel lanes
- Provide splash boards in ice or snow zones at railroad crossings

Protective screening limits and extends:

- Provide protective screening over all travel lanes plus a minimum of 10 feet beyond the travel lanes on each side. Where on or off ramps also cross under a structure, ensure screening also extends at least 10 feet beyond the end of any ramp travel lanes.
- Screening is required for all structures crossing over a railroad. Extend screening 25 feet minimum from centerline of nearest track or railroad access road.
- In areas where aesthetics is a consideration and when screening does not extend to the end of the structure, provide an additional transition panel (sloped panel or partial height panel) at the end of each run of screening as an aesthetic termination. For divided highways, continue protective screening uninterrupted through the median. For unusually wide medians and/or divided highways with a significant elevation difference for each direction, protective screening may be interrupted through the median with the use of transition panels, if appropriate.
- Provide protective screening on both sides of a structure even when a sidewalk is provided on just one side. Where twin structures cross a high-speed facility, provide protective screening for the center opening between structures

1.13.4.2 Design Deviation

When protective screening is not provided for structures otherwise meeting the criteria above, obtain approval of a design deviation from the State Bridge Engineer. Provide the following with any request for a design deviation:

- Basis for the proposed design deviation.
- Concurrence from the Region Roadway Manager.
- A plan of the bridge showing sight lines obstructed by the proposed screening if the basis for the exception is lack of sight distance.

- A description of pedestrian activity including width of sidewalks and proximity to pedestrian sources such as schools, playgrounds, or athletic fields.
- The history of incidents and/or signs of graffiti at the bridge site or sites in the vicinity.
- The distance to adjacent bridges also crossing the facility and whether they have screening.
- The approximate cost of widening the structure when widening would avoid a sight distance hazard.

Note that installation of protective screening is mandated by law (ORS 366.462). Proposals to deviate from the screening requirement must be complete and thorough. Public and/or legislative oversight of design deviations for protective screening is likely.

1.13.4.3 Other Considerations

Sight Obstruction - Screening may obscure the intersection sight distance at ramps, cross-streets, or driveway accesses off the end of the structure, non-signalized intersections increase this potential hazard. Stopping screening after it is no longer required may solve some of the problems. However, some cases will require specialized designs.

Vertically Curved Screening - Curved screening is not required, but may be considered when a sidewalk is present. Curvature is an additional deterrent because it forces the thrower into the roadway in order to clear the screening. Note that curved screening may cause an additional sight obstruction. Curved screening may require additional height to accommodate bicycles and, in some cases, horses with riders. Curved screening will not require end treatment.

Horizontally Curved Structures - On horizontally curved structures, give consideration to potential sight distance problems that may occur due to the screening. On structures with tight curves, it may be necessary to use straight screening rather than curved screening because it is difficult to construct curved screening on a tight curve and obtain proper fit of the chain link fabric. When chorded screening is used on a tight curve, ensure any “gap” between the bottom of screening and the curved edge of the bridge does not exceed 3 inches. Such “gaps” may be closed using plates attached to concrete surfaces near the bottom of the screening.

Under Structure Screening - In the Portland area, Region is concerned about homeless people sleeping under bridge end bents. In some cases chain link screening may not be adequate, because it is easily cut. Under structure screening in urban areas may need to be partially buried to prevent tunneling. Consult Region and local districts for end bent treatment.

Aesthetic Considerations – Chain link is the most economical screening available. However, chain link has very low aesthetic value. There are low-cost methods available for improving the aesthetics of chain link screening:

- End treatment – Providing a special termination section at each end of each screening run is a low-cost and effective aesthetic enhancement. This can be as simple as tapering the ends (for example, see *Dwg 65137*) or a reduced-height panel. Any end treatment with a height less than the minimum required must start at least 10 feet beyond any travel lanes or ramps (25 feet from tracks or access road for railroad crossings).
- Color – Use of vinyl-coated chain link can greatly improve the appearance of chain link at a very modest increase in cost. Possible colors are black, navy blue, or dark green depending on location. Hot-dip galvanize screening before vinyl-coating.

End treatment and color are proven ways to improve the aesthetics of chain link screening. There are likely other effective options. Designers are encouraged to seek input from others (designers, district, and/or local community) when using aesthetic concepts outside these proven methods. What may appear attractive to a designer may not be desirable to others.

External Requests for Ornamental Screening – ODOT has received requests from local communities to install ornamental screening on existing structures. A number of issues must be addressed before a request can be processed:

- Funding – Ornamental screening can be included in ODOT Modernization projects, if deemed an important architectural item by the project team and supported by the Environmental study. For retrofit to an existing structure (not associated with an ODOT project), include possible funding sources with the proposal.
- Permits – If someone other than ODOT proposes to install a feature in ODOT Right-of-Way, they must obtain a permit from the District it is located in.
- Design – Do not create a distraction for drivers with ornamental protective screening. Check for any sight distance problems it could potentially create. Review design outside of ODOT's normal standards through a review process with the District, Tech Center, Office of Maintenance and others to assure it is appropriate and meets clearances and standards as given by ODOT.
- Maintenance – Responsibility for maintenance must be established in case of damage or deterioration. Districts are funded to maintain ODOT standards. If designed and installed by forces outside of ODOT, resources are required to maintain it which should include a bond, city or county taking responsibility.

Also see **BDM 2.3.10**, "Structure Appearance and Aesthetics, Ornamentation".

1.13.4.4 Protective Screening Standard Details

Screening on new structures when needed, will be as follows and as shown on *Figure 1.13.4A* and Standard Drawings *BR240*, *BR241*, *BR242* and *BR245*, or Standard Detail *DET3243* and *DET3244*.

- Bridges with Sidewalks - See Details "A", "B", "C", "D" on *Figure 1.13.4A*.
 - If a barrier is placed between the sidewalk and roadway, use screening in place of a pedestrian rail along the outer edge of the structure.
 - If the sidewalk is not separated, place screening behind or attached to the combination rail along the outer edge of the structure.
- Pedestrian Bridges - See Detail "E" on *Figure 1.13.4A*. Pedestrian bridges will be screened in most instances, including all instances where pedestrian bridges cross a vehicular facility.
- Certain sweepers will not fit through curved fence enclosures. Region 1 sweepers measured 10'-5". Standard Drawing *BR240*, Type "A" Fence Section has provisions to allow access. Contact Region to determine an acceptable type of fence.
- Railroad Undercrossings - See Details "A", "B", "C", and "D" on *Figure 1.13.4A*.
 - Splash boards are required where switching is performed or where there are other frequent activities. Typical details are shown on *Figure 1.13.4B* and *1.13.4C*.

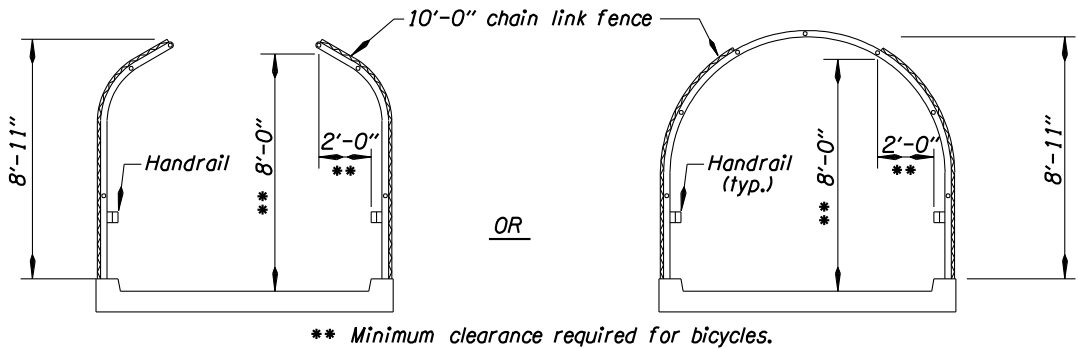
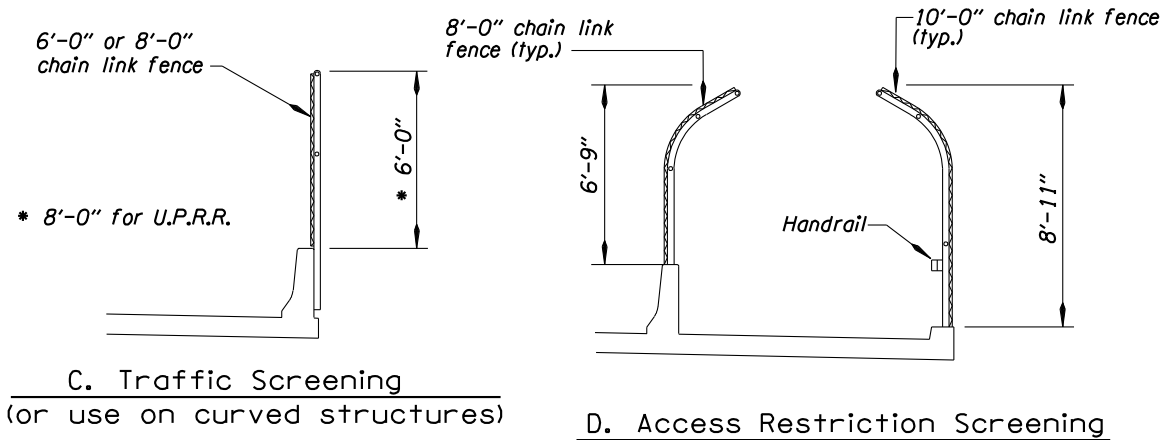
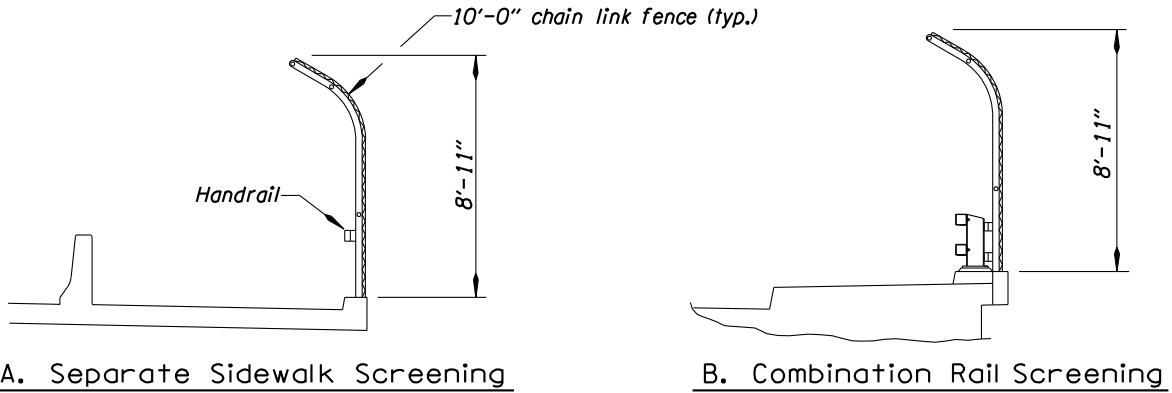

Figure 1.13.4A

Bridge Design Manual – June 2020
 Oregon Department of Transportation
 Section 1 – Design Standards

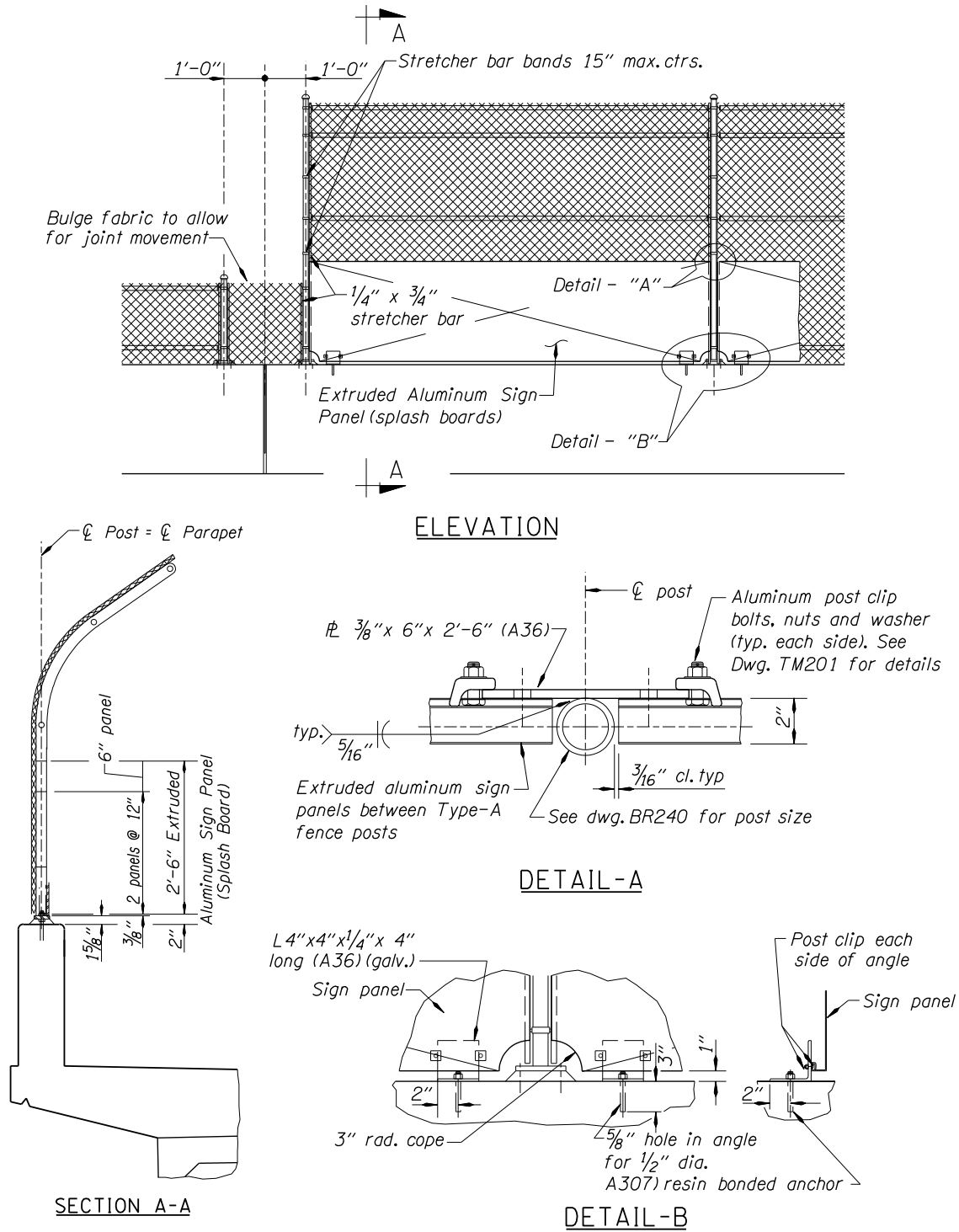
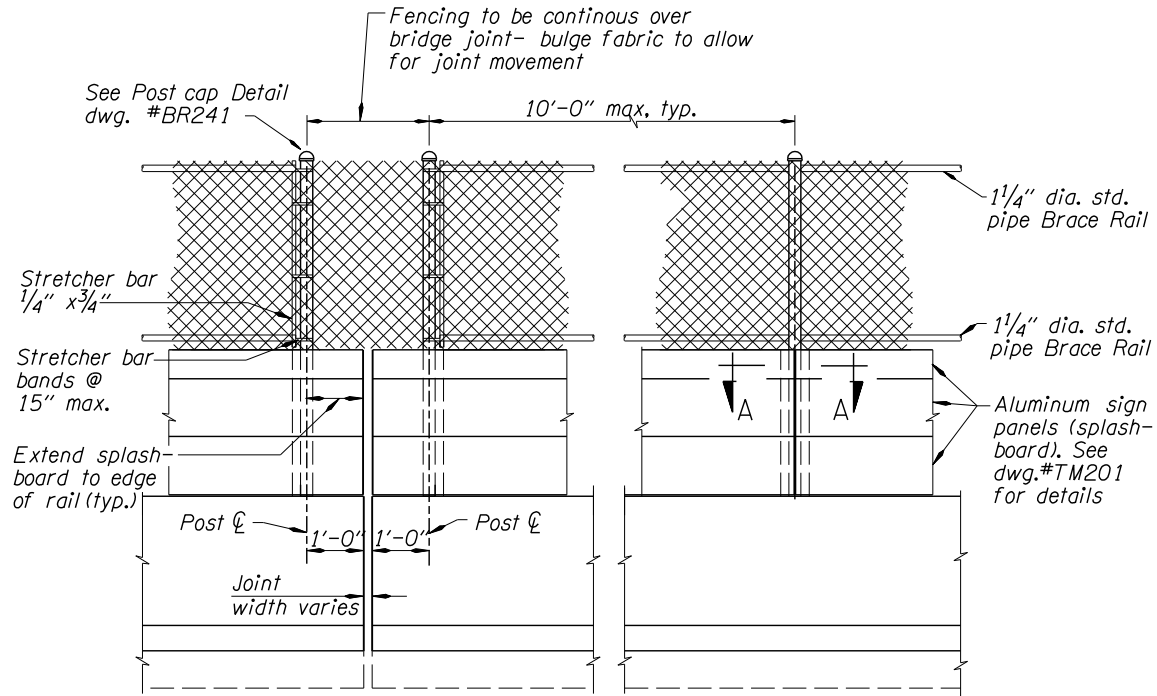
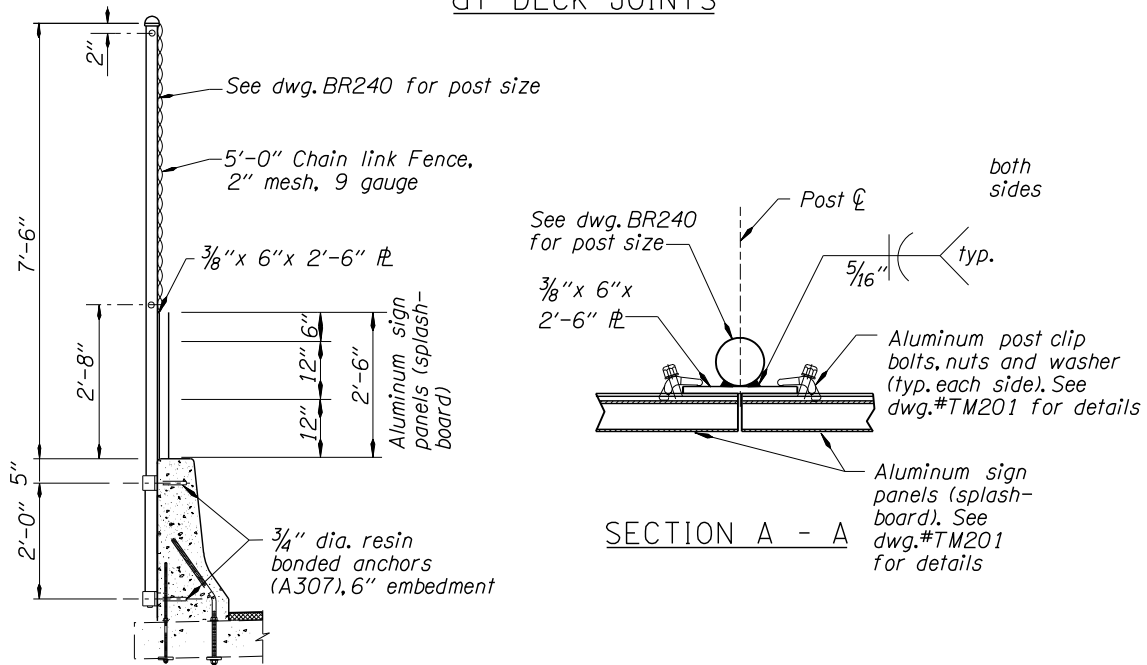

Figure 1.13.4B

Bridge Design Manual – June 2020
Oregon Department of Transportation
Section 1 – Design Standards



ELEVATION TYPE 'C' FENCE
at DECK JOINTS



SECTION A - A

TYPE 'C' FENCE SECTION

Figure 1.13.4C

1.14 BEARINGS AND EXPANSION JOINTS

[1.14.1 Bearings](#)

[1.14.2 Expansion Joints](#)

[1.14.1 Bearings](#)

1.14.1.1 Design, General

Provide provisions for bearing replacement, including temporary jacking and support for all manufactured bridge bearings. There is a potential of bearing failure during the service life of a bridge, which requires that provisions for bearing replacement be provided in the design drawings. Providing temporary jacking support (design, detailing and construction) on existing structures is complex and increases the maintenance cost and life cycle cost of a bridge. Including consideration of jacking and temporary support in the original design will reduce future rehab cost and ease future bearing replacement. This work may require pilecap or crossbeam widening, or widening under each girder. Show grout pad locations in the contract drawings for temporary jacking support and a bearing replacement sequence and minimum jacking loads. Check the adequacy of all affected structural elements during bearing replacement and stability of the structure.

1.14.1.2 Elastomeric Bearing Pads

Elastomeric bearings are used to accommodate movements on short to medium-span structures. The three types of pads include:

- plain pads
- laminated pads reinforced with fabric (fiberglass)
- laminated pads reinforced with steel.

Plain pads are made from elastomer molded or extruded into large sheets, vulcanized and then cut to size.

Do not use cotton duck pads or random Oriented Fiber Pads bearing for slabs and box beams construction. Use plain elastomeric (neoprene) pads instead.

Fabric reinforced pads are made from alternate layers of elastomer and fabric (usually fiberglass) in large sheets, vulcanized and then cut to size. Fabric reinforced pads are restricted to short to medium spans with little or no skew.

Steel reinforced pads are made from alternate layers of elastomer and steel cut to size and then vulcanized. A thin cover layer of elastomer encapsulates the steel to prevent corrosion. The exposed edge voids in the pads caused by the steel laminate restraining devices are shop sealed with an appropriate caulking material.

Use Method "A" to design elastomeric bearings. Where there is a need to use Method "B", specify in the Special provisions and contract drawing that the Method "B" was used. Elastomeric bearings designed using Method "B" requires extra testing.

Use the following movements for pad thickness design:

$$ES + LF_1*(CR+SH) + LF_2*(TF \text{ or } TR)$$

Where:

- ES = elastic shortening movement
- CR = creep movement CR = (ES)(CF)
- SH = shrinkage movement
- TF = temperature fall movement
- TR = temperature rise movement
- CF = creep factor
- LF₁ = from *LRFD 3.4.1*
- LF₂ = TU, Load Factor from *LRFD Table 3.4.1-1*

Use proper signs and the Service Limit State Load Factor that produces the largest movement in each load combination.

The final elastomer thickness is 2 times the design movement. Size the nominal pad thickness in multiples of 1/2 inch, from 1/2 inch to 6 inches maximum. The actual finished thickness will vary depending on the type of reinforcement. Fabric has a negligible thickness. Steel plate thickness may vary with the manufacturer, but be a minimum of 14-gauge.

The creep factor above is taken as 1.5 for both prestressed and post-tension concrete structures. Shrinkage movement is calculated using 0.0004 times the total length of the structure. For prestressed concrete structures 40 percent of this movement takes place within the first thirty days after manufacture. Therefore, the amount of creep and shrinkage movement for these structures, after placement, can normally be taken as 60 percent of the total.

Values for shortening of post-tensioned, cast-in-place concrete bridges have been determined by field measurements by the ODOT Bridge Section. See *BDM 1.5.8.1*. Compare the design values with the field measured values and use the more conservative values.

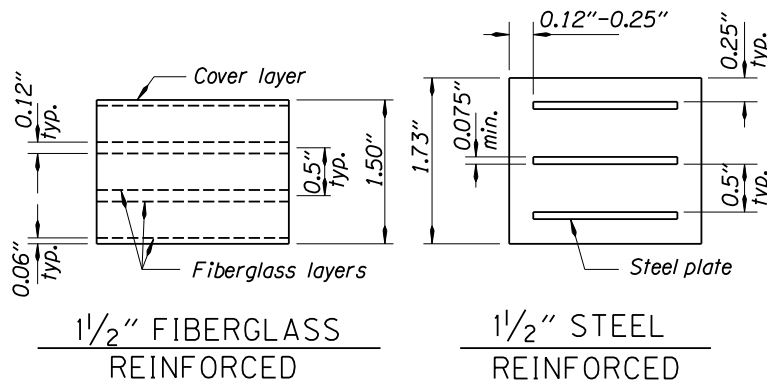
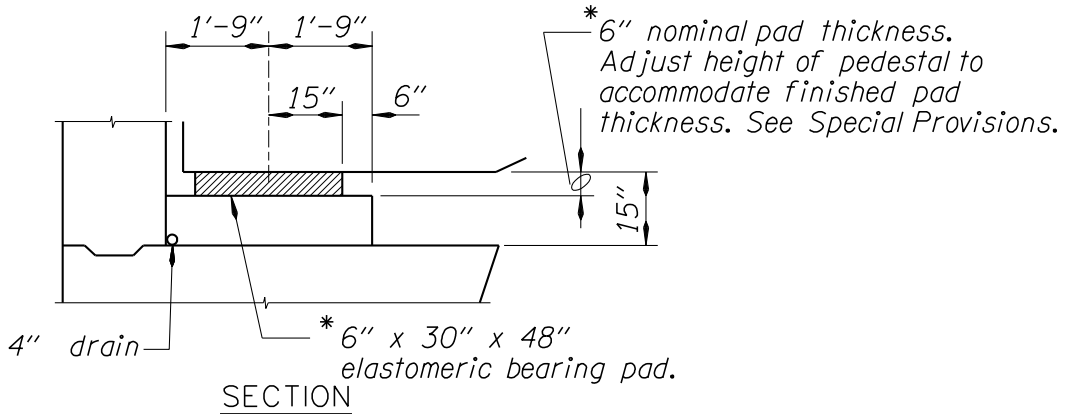

Figure 1.14.1.2A

Pad thickness called for on detail plans is the total thickness of the elastomer required. If bearing pad elevations are shown, list the assumed finished pad thickness. Use circular elastomeric bearing pads for curved steel girders.

Examples are shown below.



ELASTOMERIC BEARING PAD

(No Elevations Shown)

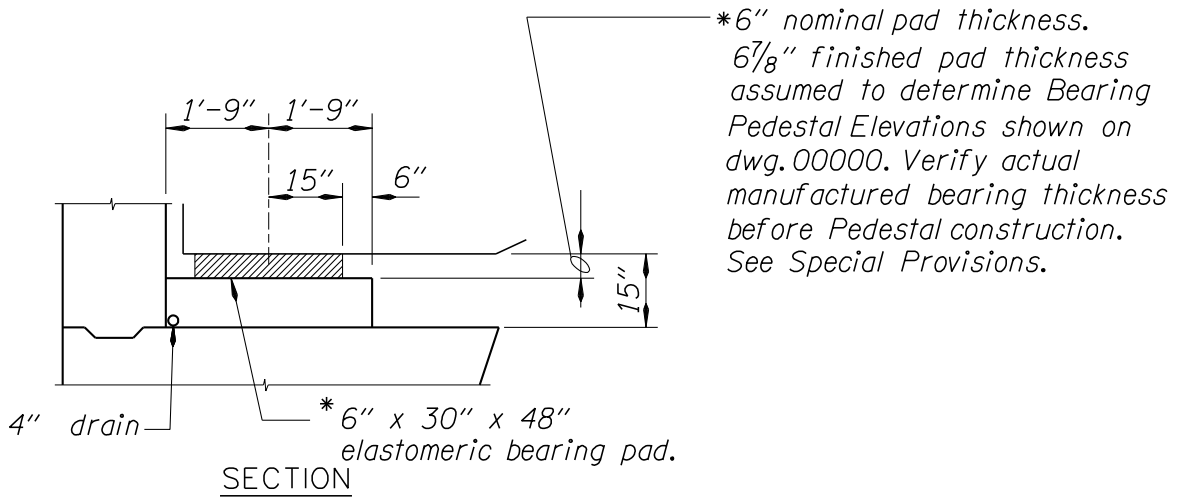

ELASTOMERIC BEARING PAD

(Elevations Shown)

Figure 1.14.1.2B

For prestressed slab and box beam bearing pad sizes, use [Figure A1.11.1.7D](#) (end bents) or [Figure A1.11.2.2C](#) (interior bents).

1.14.1.3 Proprietary Pot, Disc, Slide, Radial, or Spherical Bearings

These bearings are normally used on long-span and post-tensioned concrete structures where the design movement cannot be accommodated with elastomeric bearings.

When provided to allow longitudinal movement for concrete superstructures, design bearings to accommodate the anticipated effects of shrinkage, creep and elastic shortening (where applicable) as well as temperature.

Use the following movements for proprietary bearings:

$$\begin{aligned} \text{Shortening:} \quad & ES + LF_1*(CR + SH) + LF_2(TF) \\ & ES + LF_1*(CR + SH) + LF_3(EQ) \end{aligned}$$

$$\begin{aligned} \text{Lengthening:} \quad & LF_2*(TR) \\ & ES + LF_1*(CR + SH) + LF_3(EQ) \end{aligned}$$

Where:

ES = elastic shortening movement

CR = creep movement $CR = (ES)(CF)$

SH = shrinkage movement

TF = temperature fall movement

TR = temperature rise movement

CF = creep factor

EQ = Maximum design earthquake displacement (movable bearings)

$LF_1 =$ from *LRFD 3.4.1*

$LF_2 =$ TU, Load Factor from *LRFD Table 3.4.1-1*

$LF_3 =$ Load Factor from *LRFD Table 3.4.1-1*

Use proper signs and the Service Limit State Load Factor that produces the largest movement in each load combination.

The creep factor above is taken as 1.5 for both prestressed and post-tension concrete structures. Shrinkage movement is calculated using 0.0004 times the total length of the structure. For prestressed concrete structures 40 percent of this movement takes place within the first thirty days after manufacture. Therefore, the amount of creep and shrinkage movement for these structures, after placement, can normally be taken as 60 percent of the total.

Values for shortening of post-tensioned, cast-in-place concrete bridges have been determined by field measurements by the ODOT Bridge Section. See *BDM 1.5.8.1*. Compare the design values with the field measured values and use the more conservative values.

Bridge Design Manual – June 2020
Oregon Department of Transportation
Section 1 – Design Standards

Detail the initial position of expansion bearings so that the bearing will behave satisfactorily after the design movement has taken place.

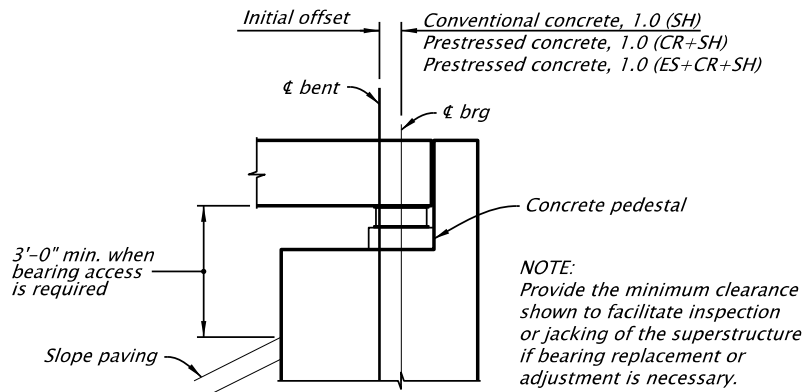

Figure 1.14.1.3A

Performance Specifications for Approved Proprietary Bridge Bearings are now covered by the Standard Specifications. Approved bearings are listed in the *Qualified Products List*, which is available on the ODOT website.

The designer must check the shop drawings, specified test results, and certifications for compliance with these specifications.

When proprietary bearings are used, show the following details and information in the contract plans:

(1) Schematic Drawing - A schematic drawing of the bearing showing the method of attachment of the upper and lower units to the superstructure and substructures, respectively. See *Figure 1.14.1.3B* for an example.

(2) List design notes for:

- Required clearance to edge of concrete support
- Maximum allowable concrete bearing stress
- Minimum rotational capacity of bearing (not less than 0.015 radian)
- Any restriction as to type of bearing (pot, disc or spherical)
- Reference to bearing schedule for load and movement capacity.
- Reference to standard specifications for painting.
- Reference to the *Qualified Products List* for approved bearings.

Paint all exposed surfaces of the bearing devices except teflon, stainless steel, machine finished or polished bearing surfaces, as set forth in *SP 00594*. Provide a primer coat only for portions to be in contact with concrete and for steel to steel contact surfaces.

Bridge Design Manual – June 2020
 Oregon Department of Transportation
 Section 1 – Design Standards

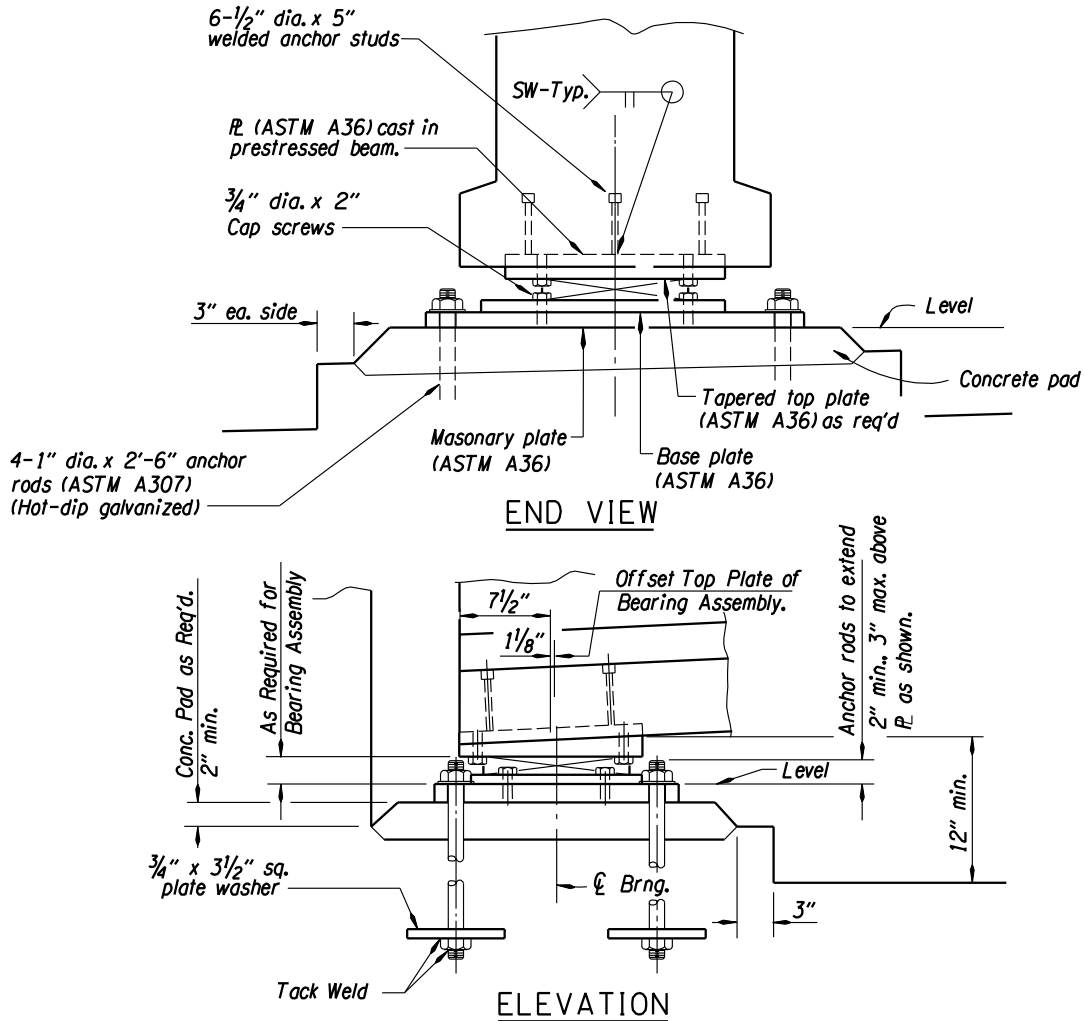

Figure 1.14.1.3B

(3) Bearing Schedule – Include the following items in the Bearing schedule:

- Location of bearing (bent number)
- Number of bearings required (number per bent)
- Bearing fixity (fixed, guided or non-guided)
- Final dead load (load/bearing)
- Vertical design capacity (dead load + live load + impact, load/bearing)
- Horizontal design capacity of fixed and guided bearings (not less than 10 percent of the vertical design capacity).

Bridge Design Manual – June 2020
Oregon Department of Transportation
Section 1 – Design Standards

The specification requires each guided bearing to resist the entire horizontal load at any one bent. Use no more than two guided bearings per bent or hinge. Where more than two guided bearings are required, provide devices independent of the bearings to resist horizontal loads. Use non-guided bearings at these locations.

Design movements for:

- Mean temperature
- Temperature rise
- Temperature fall
- Creep, shrinkage and elastic shortening
- Change in bearing centerline per specified temperature increment

Ensure the top bearing plate dimensions are adequate to compensate for the initial bearing offset shown.

Provide additional bolted plates with the top and bottom plates of the bearing assembly to facilitate removal of bearing for repair or replacement and to provide a level surface for the bearing unit.

BEARING SCHEDULE													
Bent	No. Req'd	Type	Design Load Capacities in kips per Bearing			Initial Offset	Calculated movements			Movement per 10°F Temp. change	Minimum Movement Capacity from Initial Position		
			Vertical	Lateral	Longit.		30°F Temp. Rise	40° F Temp. Fall	Creep, shrinkage & Elastic shortening		Temp. Rise Direction	Temp. Fall Direction	Total
1 & 5	4	Guided	1000	*600	—	3"	7/8"	1 1/4"	4 1/2"	5/16"	1 1/2"	7 1/2"	9"

* Reduce design load to 200 kips for PTFE surface only.

Figure 1.14.1.3C

1.14.1.4 Bearing Replacement

Consider the potential of expansion bearing replacement during the life of the structure in sizing of crossbeams and bents. Provisions may need to be made for jacking locations.

If a bent is accessible (close to the ground, out of traffic, etc.) it may be assumed that a falsework jacking bent can be constructed and no special provisions on the bent are required. See [BDM 1.38.4](#) for additional guidance.

If the bent is not easily accessible, provide provisions for jacking, such as a wider crossbeam or strengthened diaphragm beam.

1.14.1.5 Reinforced Concrete Bearing Seats

(1) Clearance - The minimum horizontal clearance from the edge of a bearing plate, or 1 inch and thicker elastomeric bearing pad, to the edge of a concrete bearing seat shall be 6 inches, or 3 inches plus the thickness of grout under the bearing, whichever is greater. Where the bearing is skewed with the bent, this dimension may be reduced at the corner of the pad. Locate anchor bolts a minimum of 6 inches clear of the nearest face of concrete.

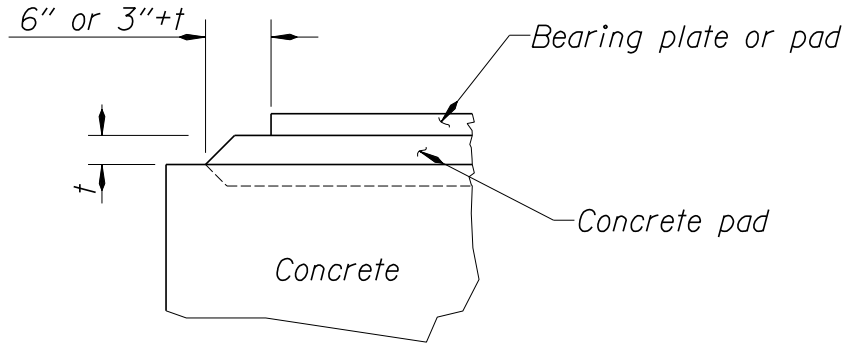

Figure 1.14.1.5A

(2) Additional Reinforcement - Generally, detail a reinforced concrete buildup, as shown below, under the bearings of all prefabricated beams, except precast slabs and box beams less than 70 feet in length.

Certain bearings may require no concrete buildup but have the bearing surface ground to grade.

Note:

Pour 2" concrete pad, allow concrete to cure 3 days or until concrete obtains design strength.

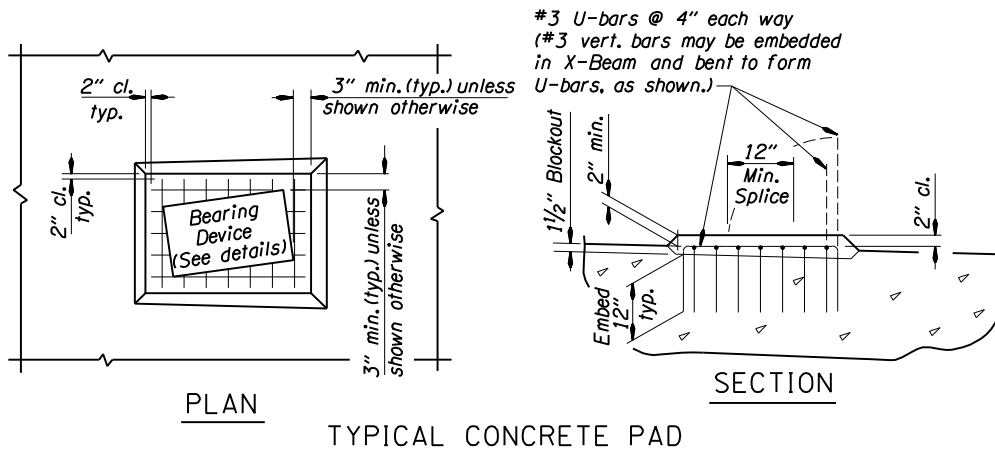

Figure 1.14.1.5B

1.14.1.6 Unreinforced Bearing Seats (Prestressed Slabs and Boxes)

(1) General – For prestressed slabs and boxes, provide bearing details as shown in *Figure 1.14.1.6*.

Set precast concrete slabs over 40 feet in length on elastomeric bearing pads. Do not allow cotton duck pads as a replacement for elastomeric bearing pads.

Note:

Place 1/2" concrete layer on concrete pad, place elastomeric bearing pads and preformed expansion joint filler on concrete layer. Place slabs on bearing pads before the concrete layer is fully set to ensure uniform bearing across full width of the slab. If uniform bearing is not achieved, lift slab and repeat procedure. Remove any excess concrete protruding above the bearing pads immediately after placing slab.

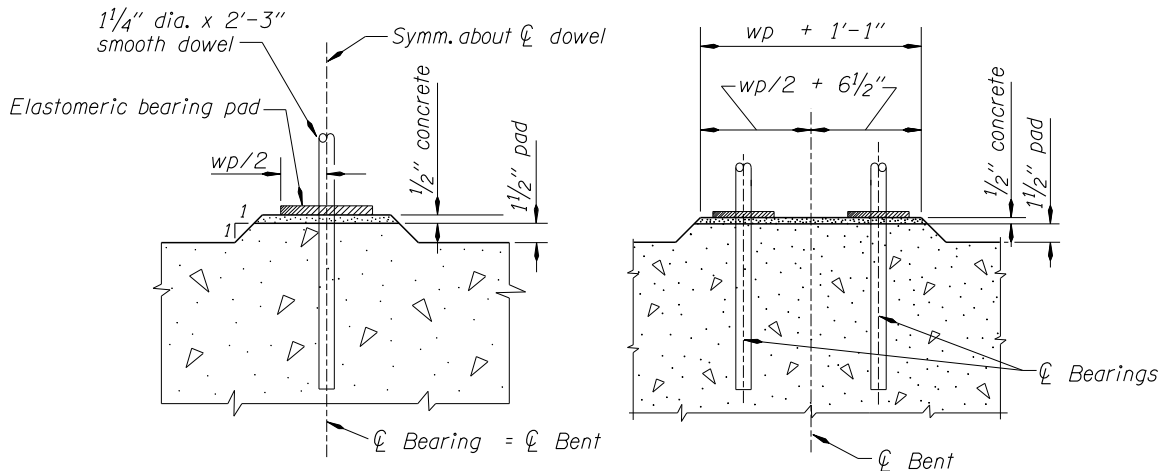

BEARING AND CONCRETE PAD DETAILS

Figure 1.14.1.6

(2) Construction Procedure -

STEP 1. Pour 1-1/2 inch concrete pad, allow concrete to cure for 3 days or until concrete obtains design strength

STEP 2. Place 1/2 inch concrete layer as shown in *Figure 1.14.1.6*.

1.14.2 Expansion Joints

1.14.2.1 Deck Expansion Joint Seals

Consider integral abutment or semi-integral abutment wherever criteria in *BDM 1.11.2.4* are met. For short span bridges with pin end bent connection use preformed expansion joint filler. These joints are the least expensive joint and easy to repair. Design expansion joint seals to provide for the effects of temperature, shrinkage and creep.

Skew Angle – Use skew angle ± 5 degrees different from snow plow angle for all joints except asphaltic plug joints. Normally the angle of attack of snowplows is skewed 30 degrees to the roadway alignment. Snowplow blades can fall into the joint where the skew angle of the joint matches the snowplow's angle, resulting in danger to the snowplow driver or traffic. Consider the effect of skew angles on future widening of the structure.

(1) General Information and Definitions

Armored Joint - Steel armoring to protect the vertical edges of a joint opening. The armor may be steel shapes.

Asphaltic Plug Joint (APJ) Systems - A closed expansion and contraction joint system composed of aggregate and flexible binder material placed over a steel bridging plate.

Closed Expansion Joint - A joint in which a seal material is placed to prevent water or debris from entering the joint. This includes poured joint seals, compression joint seals, asphaltic plug joint systems, preformed strip seals, and modular bridge joint systems.

Filled Joint - A filled joint using a preformed joint filler placed prior to the concrete pour. Hot applied joint sealant is placed on top of the joint filler.

Hot Applied Joint Sealant - A hot-poured asphaltic material for use in sealing joints.

Modular Bridge Joint Systems (MBJS) - A closed expansion and contraction joint using a series of continuous preformed strip seals inserted into steel shapes to seal the joint.

Poured Joint Seal - A closed expansion and contraction joint sealed with a rapid-cure poured joint sealant (2 part silicone).

Precompressed Foam Silicone Joint (PFSJ) Seal - A closed expansion and contraction joint system consisting of a preformed, pre-compressed, silicone-coated, self-expanding foam joint system bonded to joint faces using epoxy adhesive.

Preformed Compression Joint Seal - A closed expansion and contraction joint sealed with a continuous preformed elastomeric compression gland.

Preformed Joint Filler - A preformed expansion joint material having small extrusion and substantial recovery after release from compression.

Preformed Strip Seal System - A closed expansion and contraction joint using a continuous preformed elastomeric gland (strip seal) inserted into an extruded or formed steel retainer bar with steel anchors.

Use preformed single strip seals to seal deck joints with up to 4 inch range of movement (1-1/2 inch minimum installation width). For joints of greater anticipated movement, use a modular bridge joint system. It is not recommended to use a modular bridge joint system solely to provide for possible seismic movements.

Preformed compression seals may be specified for joints with a design movement of up to 1-3/4 inches.

Asphaltic plug joint seals **are suitable for joints between 2 pavements with asphalt concrete wearing surface and** may be specified where following conditions are satisfied:

- Maximum range of design movement up to 1-1/2 inches (total)
- Maximum bridge skew less than 45 degrees
- Maximum lateral movement at joint 1/4 inch
- Maximum vertical movement at joint (uplift) 1/4 inch
- Maximum superelevation of 6%

Asphaltic plug joint seals do not perform well under following conditions:

- Where traffic is accelerating or decelerating, such as intersection with traffic lights or stop signs.
- Bridge with a curved horizontal alignment.
- Longitudinal joint between two structures. Skid resistance of this joint diminishes with time and it may become a hazard to motorcyclist and bicyclists.

Specify precompressed foam silicone joint seals for joint rehabilitation only. PFSJ seals may be specified for joints with a design movement up to 2-1/2 inches. Limit a joint installation width smaller than 3 inches to ensure joint performance. Field verify the joint width. This joint system can be field-spliced, which makes it suitable for staged construction and partial joint repair. Specify factory-fabricated bends for inside corners at the gutter line. Field verify a bend angle required for the existing inside corner and show the bend angle on project plans. When joints cross sidewalk, specify a PFSJ seal system that is suitable for pedestrian traffic and provide joint details according to RD722. Splicing between bridge and pedestrian PFSJ seals are possible.

See Standard Drawings BR139, BR140, BR141, BR145, BR157 and DET3150 for joint details.

Drawings BR141, BR145 and DET3150 show the depth of metal to be 8 inches, with a plate being welded to the 2 inch deep rail section.

For modular joints, the bottom of the rail section must be the same depth as the bearing boxes, as noted as "Point F" on Drawing BR150.

Check the *Qualified Products List* for the currently acceptable materials and joint systems.

(2) Expansion Joint Blockout

Show a blockout detail on the plans to allow the expansion joint assembly to be placed a period of time after the final deck pour. Providing a blockout makes the adjacent deck pour easier, provides smoother deck transition to joint, and allows the majority of the superstructure shrinkage to occur prior to joint assembly placement.

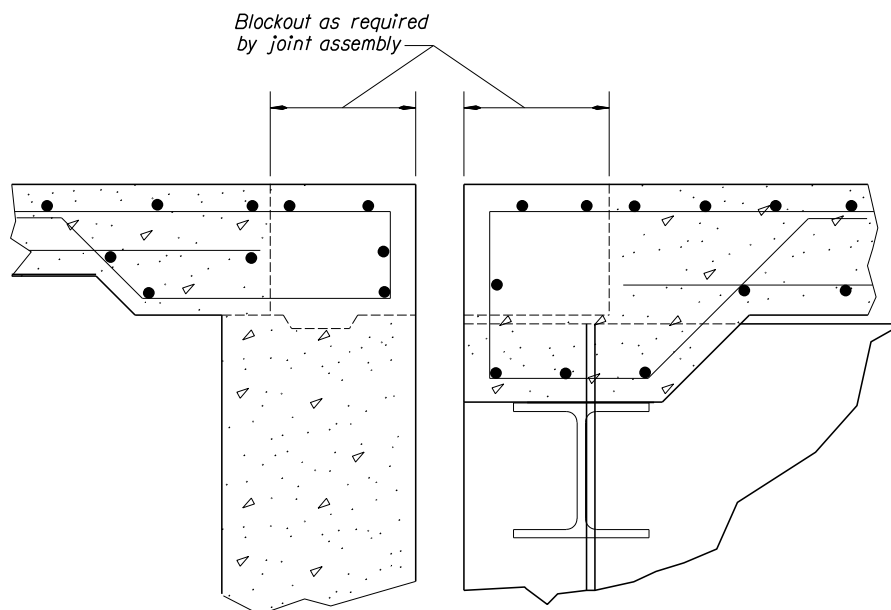

Figure 1.14.2A

(3) Expansion Joint Setting, General

Use a minimum change of joint width due to shrinkage of 1/4 inch per 100 feet for the full length of non post-tensioned concrete segments (both pretensioned and conventional).

Use a minimum change of joint width due to creep and shrinkage of 1/2 inch per 100 feet for the contributing length of post-tensioned segments.

Use the following equations for calculating thermal effects:

Steel Girder Superstructure: $R = LF*(TR + TF)$

Concrete Superstructure: $R = LF*(TR + TF) + LF*(CR + SH)$

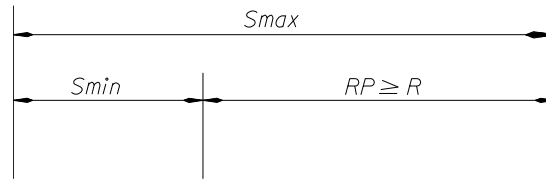

Figure 1.14.2B

Where:

- S_{min} = Minimum serviceable seal width
- S_{max} = Maximum serviceable seal width
- R = Required seal range
- RP = Provided seal range ($S_{max} - S_{min}$)
- CR = Creep movement $CR = (ES)(CF)$
- SH = Shrinkage movement
- TF = Temperature fall movement
- TR = Temperature rise movement
- ES = Elastic shortening
- CF = Creep factor
- LF = Load Factor from *LRFD Table 3.4.1-1* and *LRFD 3.4.1*

Use the Strength Limit State Load Factor that produces the largest movement in each load combinations.

	<i>Conv. Concrete</i>	<i>Prestressed Concrete</i>	<i>P/T Concrete</i>
<i>CREEP: CREEP FACTOR</i>	—	1.5	1.5
<i>Portion of CREEP to use</i>	—	50%	70%
<i>SHRINKAGE: ult</i>	0.0004	0.0004	0.0004
<i>Portion of SHRINKAGE to use</i>	60%	60%	60%

Figure 1.14.2C

For the compression seals shown on Drawing *BR140* S_{min} and S_{max} are the width of the seal under a compressive force of 50 and 10 pounds per inch, respectively. In skewed joints, S_{min} and S_{max} may be limited by the allowable shear deformation of the seal. For the seals shown on *BR140*, always limit shear deformation of the seal to 10 degrees.

(4) Joint Setting at Mean Temperature

In most cases, the range of serviceable seal width provided by a standard joint seal (RP) will be somewhat larger than the range required by design (R). Equally distribute this excess $[E = RP - R]$ for expansion and contraction.

The following schematics show joint settings for the two design cases above:

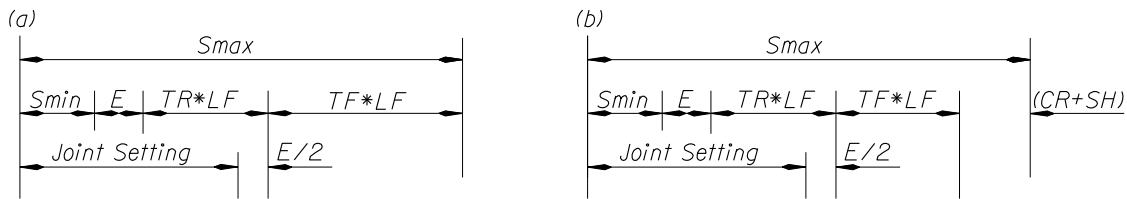

Figure 1.14.2D

Use the following form to call out joint settings on the plans:

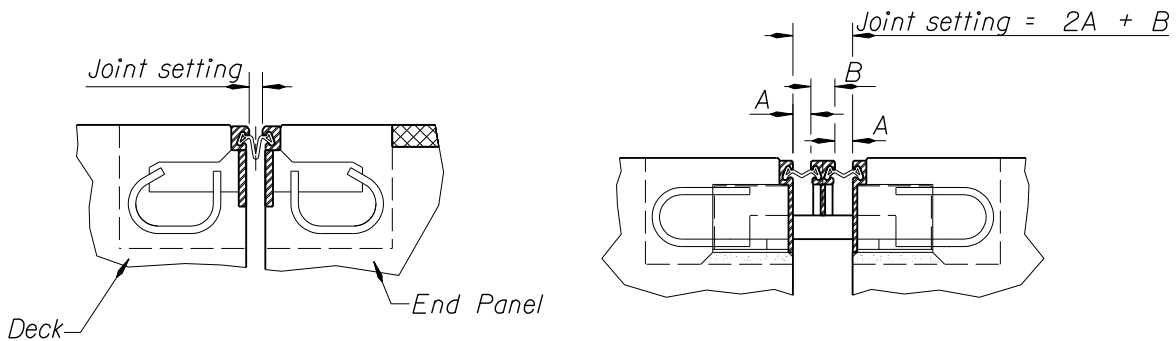

Figure 1.14.2E

Decrease Joint setting ___ inches for every 10°F of structure temperature above ___°F.

Increase joint setting ___ inches for every 10°F of structure temperature below ___°F.

Expansion joints are normally set after tensioning is complete, so elastic shortening is not included in the joint setting width.

1.14.2.2 Electrical Conduit Expansion Joint

At those locations on the structure where an electrical conduit crosses an expansion joint, show a detail similar to the following on the plans:

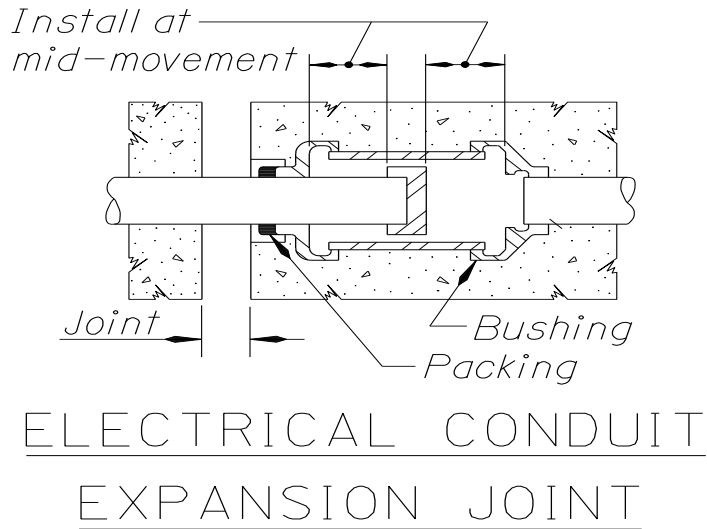

Figure 1.14.2F

1.15 SOUNDWALLS

[1.15.1 Soundwalls, General](#)

[1.15.2 Soundwalls mounted on Bridges](#)

[1.15.1 Soundwalls, General](#)

Design soundwalls according to the guidelines provided in *LRFD Section 15*, and ODOT Geotechnical Design Manual, *Section 16.6*.

Investigate the soil condition specific to the soundwall site and included in the Geotechnical Report. It is recommended that this be taken care of early in the project's development.

The design and detailing requirements for soundwalls on bridges and retaining walls adjacent to the traveling public are different than the ones away from the traveling public. The failure of these soundwalls is a safety hazard for the traveling public.

[1.15.2 Soundwalls mounted on Bridges](#)

Soundwalls should not be located on bridge structures where feasible alternative locations exist. Soundwalls on bridge structures cause a disproportionate increase in bridge cost because of strengthening of the deck overhang and exterior girder. These structures may cause increase in risk to traffic below during seismic events or in case of vehicular impact. In addition, Soundwalls on bridges interfere with normal maintenance inspection access and detract from the aesthetic quality of the structure.

Where feasible alternative locations do not exist and soundwalls must be located on bridges, limit the total height, as measured from the top of bridge deck to the top of the soundwall, to 8 feet. Obtain approval of a design deviation before specifying soundwalls taller than 8 feet.

For soundwall located on bridge, only crash tested soundwall is allowed.

On bridges where the soundwall does not meet crash test requirements of MASH Test Level 4, place soundwalls at minimum of 4 feet beyond the gutter line of an ODOT approved standard bridge railing. Soundwalls may be combined with the traffic railing as long as the structural system meets the crash test requirements of MASH Test Level 4 criteria.

In lieu of crash-testing, design soundwalls for vehicular collision forces according to *LRFD Section 15.8.4*.

1.16 ADA COMPLIANCE FOR BRIDGE WORK

[1.16.1 Americans with Disabilities Act Compliance for Bridge Projects](#)

[1.16.2 General Guidance](#)

[1.16.3 Work Activity Triggers](#)

[1.16.4 Design Considerations](#)

1.16.1 Americans with Disabilities Act Compliance for Bridge Projects

The Americans with Disabilities Act of 1990 (ADA) prohibits discrimination and ensures equal opportunity for persons with disabilities in employment, state and local government services, public accommodations, commercial facilities, and transportation. Implementation guidelines, standards, and court decisions provide guidance on how to comply with the law.

Although these sources are applied to transportation construction and maintenance decisions, there is limited guidance about specific work activities on bridges. This document provides guidance on the ADA application to the unique situations created by bridge rehabilitation and maintenance projects.

1.16.2 General Guidance

The ADA regulation prohibits discrimination against people with disabilities by government entities. Government entities must make services accessible and usable to all people, including people with disabilities. For the purpose of this document, the sidewalk of a bridge is a facility that, if provided, must be accessible and usable by people with disabilities, regardless of whether the bridge is in an urban or rural setting. The Oregon Department of Transportation (ODOT) has an obligation to ensure that a bridge infrastructure is accessible and usable, including bridge sidewalk facilities. ODOT addresses that obligation in several ways. Through the [ODOT ADA Title II Transition Plan](#), all pedestrian facilities are brought into compliance over time. Specific work will also trigger a requirement to bring certain facilities into compliance at the same time as the work is performed. Examples of specific work that triggers accessibility improvements include when a new bridge is constructed, when a new sidewalk is added to a bridge, or when the level of work on a bridge is considered to be an “alteration.” Activities that result in below-standard sidewalks require a design exception. Additionally, a project’s scope of work must not be modified solely to avoid triggering accessibility upgrades.

1.16.2.1 Altering Access or Usability of a Pedestrian Access Route

When alterations affect access to a sidewalk on a bridge, it is necessary to ensure that the sidewalk can be accessed from the approaching shoulder or sidewalk utilizing a curb ram design. When alterations affect the usability of the sidewalk itself, it is necessary to ensure that the sidewalk is readily accessible to people with disabilities to the maximum extent feasible unless it is technically infeasible to do so. Explore alternatives to improve the level of accessibility of an existing sidewalk if it is below ODOT standards. Address accessibility barriers which include narrow passages, obstructions or routes lacking sufficient passing space. Alterations must follow current ODOT policy.

Where sidewalks are not present, pedestrian travel may be expected on or along the roadway except where prohibited. Pedestrian travel in the shoulder or in the roadway when there is no shoulder is allowed, but not an exclusive service. When a sidewalk is not present, treat the existing shoulder as a pedestrian access route when determining the impact of alterations.

1.16.3 Work Activity Triggers

The [US DOJ/FHWA memorandum](#) defines an “alteration” as: A change that affects or could affect the usability of all or part of a building or facility. Alterations of streets, roads, or highways include activities such as reconstruction, rehabilitation, resurfacing, widening, and projects of similar scale and effect. Activities defined as maintenance by the US DOJ/FHWA on streets, roads, or highways, such as filling potholes, are not alterations. Upgrade each facility or part of a facility that is altered to be readily accessible and usable by individuals with disabilities to the maximum extent feasible.

Examples of alterations of bridges include rail retrofit, widening, bridge deck concrete overlays, and asphalt concrete overlays when part of a full width paving project that extends beyond the bridge. Further, when changes are made that affect the accessibility or usability of the pedestrian access route, accessibility requirements need to be addressed. An existing bridge is considered to have a sidewalk, or pedestrian access route, when the horizontal surface is at least 32 inches wide. Conversely, when the clear horizontal surface is less than 32 inches, it is not considered to be a pedestrian facility.

The work types in the list below are not considered “alterations” and are considered maintenance activities. The list is not exhaustive. Evaluate additional activities on the basis of their impact to the usability of the pedestrian facility; activities that affect the usability are considered “alterations”.

- Individual activities that do not result in changes to usability of the pedestrian facility:
 - Structural deck overlays, premixed polymer concrete overlays, deck seals, and ACWS overlays, provided these activities do not overlap the pedestrian facility (sidewalk, shoulder, and/or crosswalk)
 - Thin bonded polymer system overlays and deck seals that do or do not overlap the pedestrian facility (sidewalk, shoulder, and/or crosswalk)
 - Deck repair patching, repair of deck soffit, full depth deck repair when these activities do not span the length of the bridge or more than $\frac{3}{4}$ of the width of the pedestrian facility (sidewalk, shoulder, and/or crosswalk)
 - Under deck superstructure repair
 - Spot sidewalk repair
 - Repair of sidewalk soffit, repair of longitudinal sidewalk beams, repair of cantilevered sidewalk supports
 - Bridge Painting, cathodic protection
 - Repair in-kind of existing bridge rails
 - Concrete patching of superstructure elements, prestressed components, concrete surface finishing
 - Bonded structural strengthening (FRP, titanium, other metals, surface or near-surface), resin injection of concrete cracks
 - Seismic retrofits
 - Expansion joint repair or replacement
 - Bearing device cleaning and lubrication
 - Substructure or Foundation repair

1.16.3.1 Existing Bridges

Existing bridges may support pedestrian facilities, either by providing a sidewalk or by providing adequate shoulder width. Do not reduce existing pedestrian facilities below applicable standards.

Existing bridges that have “safety curbs” do not have sidewalks. “Safety curbs” are features with similar appearance as sidewalks, but are provided as part of a bridge rail system and do not provide access for pedestrians. The clear width of the horizontal surface of a “safety curb” is less than 32 inches.

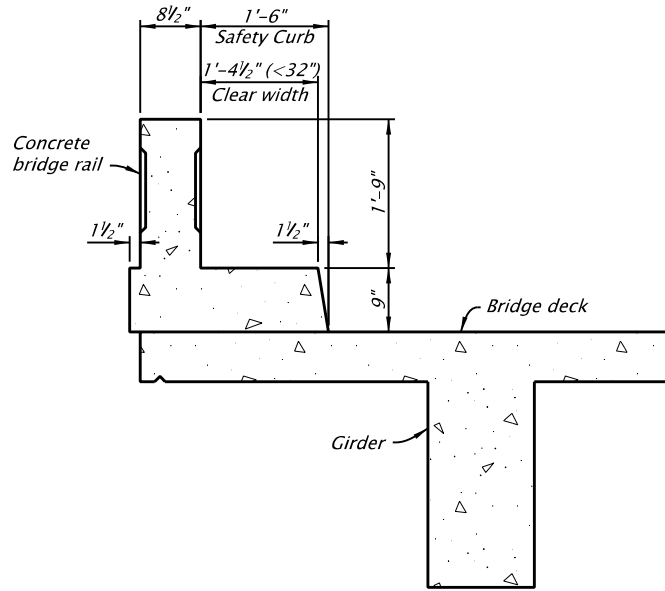

Figure 1.16.3.1.1 Existing Bridge, Section Rail with Safety Curb

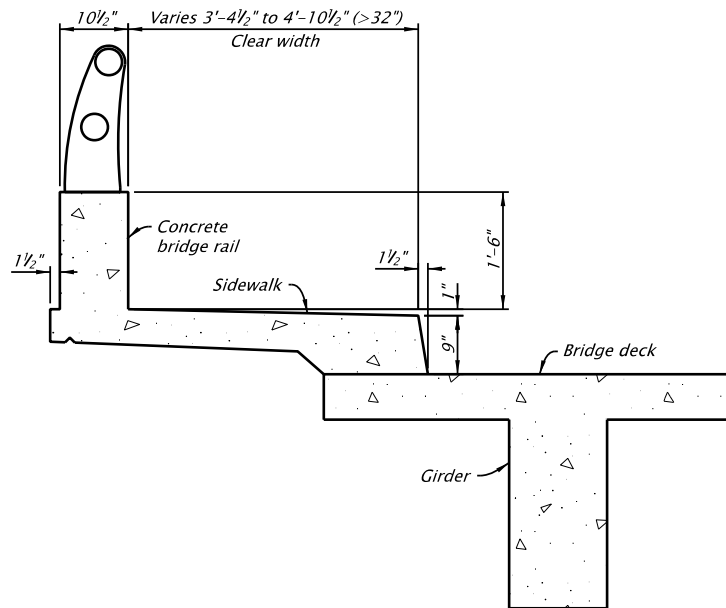

Figure 1.16.3.1.2 Existing Bridge, Section Rail with Sidewalk

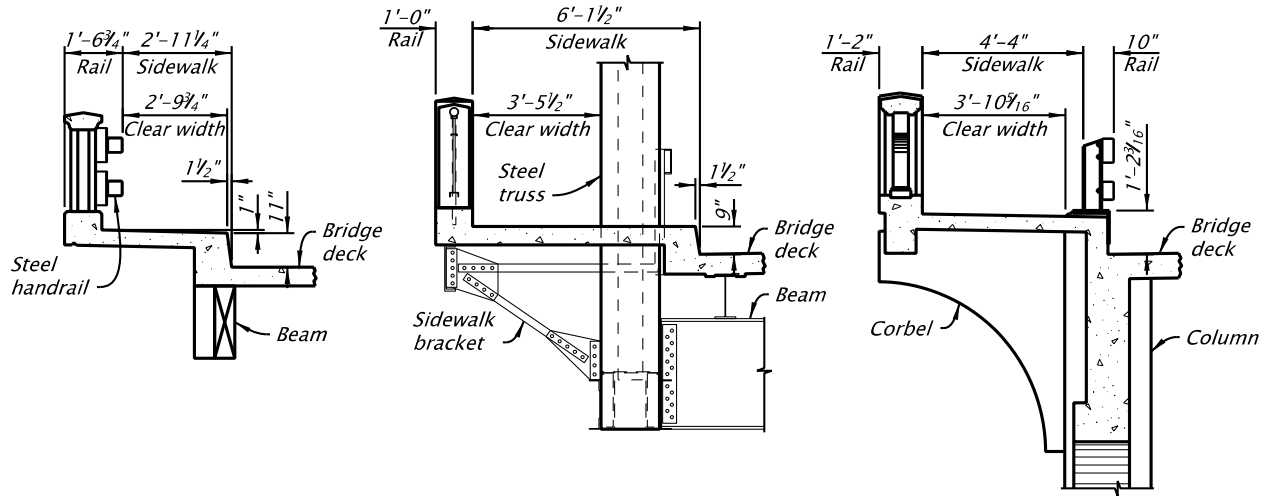

Figure 1.16.3.1.3 Existing Bridge, clear width examples

When work on an existing bridge with sidewalk is an alteration as described in [BDM 1.16.3](#), upgrade accessibility to meet full standards or to the maximum extent feasible. Refer to [HDM 13.4.3](#) for sidewalk requirements.

Feasibility of upgrades depends on numerous factors including:

- Structural capacity of the bridge to accept additional dead load and pedestrian load. Perform load rating to determine if the main structural system has additional capacity to support the upgrade.
- Additional strengthening required to support the proposed upgrade. Determine if the project may include girder strengthening.
- Structural system.
 - Thickness and reinforcement of existing concrete cantilevered sidewalks (if the existing sidewalk is thin and lightly reinforced, strengthening of the existing sidewalk might not be feasible, for example).
 - Spacing and configuration of sidewalk brackets and edge beams supporting a sidewalk.
 - Bridge deck thickness.
 - Girder spacing (may limit reasonable widening).
 - Presence of truss or arch members above deck.
- Interaction of the proposed upgrade with future program work such as rail retrofit or bridge deck widening (if a major rail or widening project is planned or needed, it may be most reasonable to improve accessibility at the same time).
- Historic preservation needs (some accessibility modifications may impact the significance of historic features of the bridge, while others may be acceptable due to limited scope of impacts or reversibility). See [BDM 1.16.4.1](#) for historic bridges.
- Roadway geometrics or roadway cross section. Roadway geometrics and cross section elements that can be reconfigured to increase accessibility of the pedestrian access route or sidewalk on one or both sides of the bridge need to be evaluated.

Document the feasibility of upgrades or reasonable upgrades/options considered. Document the rationale (i.e., the justification) for “why” the upgrade(s) or option(s) was (were) not feasible.

1.16.3.2 Rail Retrofit or Replacement

Bridge rail replacement requires upgrade of existing pedestrian facilities unless a design exception is obtained. For installation of bridge rail retrofit or bridge rail transitions at bridge ends, do not decrease the width of an existing sidewalk unless the final sidewalk width results in an accessible pedestrian route. Submit a design exception when sidewalk clear width is less than ODOT standard width.

1.16.3.3 Intersections on Bridge Structures

In some cases, intersections are located on bridge structures or at the bridge ends. The ADA requires providing or upgrading curb ramps at intersections in projects that either provide sidewalk or alter streets, roadways, or highways and span from one intersection to another. If a bridge alteration project includes an intersection it triggers the obligation to provide curb ramps at the intersection. Coordination with the roadway designer is critical in preparing curb ramp details for construction and should be reviewed by both disciplines for constructability. [Appendix 1: ADA Design of Bridge Curb Ramps](#) or [Appendix 2: ADA Bridge Works Examples](#) are posted on the [Bridge Standards website](#) for general guidance.

1.16.3.4 Temporary Traffic Control and Work Zones

For temporary traffic control and construction work, avoid impacting the pedestrian access route to the maximum extent feasible. If an existing pedestrian route is available and is impacted by work activities, provide a temporary accessible route for pedestrian traffic. For example, if an existing shoulder across a structure is four feet wide, provide a four-foot temporary pedestrian access route for pedestrian traffic. See [Temporary Pedestrian Accessible Routes \(TPAR\)](#) for more guidance.

1.16.4 Design Considerations

1.16.4.1 Historic Bridges

For bridges that are considered a historic resource, where accessibility modifications may impact the significance of historic features of the bridge, consult with the Region Environmental Coordinator and the Historic Resource Coordinator to ensure the State Historic Preservation Office (SHPO) comments are addressed. Where upgrading accessibility would conflict with federal law regarding historic preservation, neither law supersedes the other.

When there is a conflict between federal historic preservation requirements and accessibility requirements, a Design Exception is required to validate and justify any deviation from meeting the accessibility standards. With the supporting document in the Design Exception, include a letter from SHPO declaring that an adverse effect would be caused by meeting the full requirements of the ADA. Ensure the letter describes whether alternative designs or incremental ADA improvements would create adverse effects. Consider and document mitigations that will be used to minimize the impact to pedestrians with disabilities. Mitigating options might be posted minimum widths or possible accessible detours.

1.16.4.2 Technical Infeasibility and Design Exception

ADA compliance requirements are not the same as ODOT geometric design standards. The Roadway design exception process is used when geometric standards cannot be achieved. ODOT also uses the Roadway design exception process to document when it is technically infeasible to meet all the ADA criteria. Early coordination before DAP with the ODOT Roadway Engineering Unit regarding impacts to either the ODOT geometric standards or the ADA requirements is especially important. Justification for not meeting

standards is a required section of the design exception request. While costs can be used to justify exceptions to geometric standards it is not a justification for ADA criteria. See [Chapter 14 of the ODOT HDM – Design Exception Process](#) for the design exception process.

- a. **4R Standard:** 4R or modernization projects are considered the highest level of design and as such ODOT geometric standards for horizontal and vertical alignments, super elevation, lane width, shoulder width, sidewalk width are expected to be used. Document the justification for any non-standard feature not meeting the geometric design standards and the options considered in a design exception request. ODOT geometric standards for sidewalk width are wider than the minimum ADA compliance width but the ODOT geometric standard of 7 foot wide sidewalks are required unless there is an approved design exception.
- b. **3R Standard:** 3R or Rehabilitation projects are more common than 4R projects. These projects are able to retain many of the existing geometric features even when they do not meet full ODOT geometric design standards. On a 3R project a sidewalk that does not meet the full 7 foot width but does meet the accessibility criteria of a 5 foot wide sidewalk does not require a design exception. When the sidewalk width is below 5 foot, a design exception is required and 5 foot by 5 foot passing spaces must be provided every 200 feet along the sidewalk. Other geometric features that are non-standard need to be evaluated by the Roadway designer for design exception requirements.
- c. **1R Road Paving:** 1R or Resurfacing projects are the most common project type. These projects have a narrow scope defined to just surface treatments. When the resurfacing is classified as an alteration and road pavement surfacing extends from one intersection to another, provide or upgrade curb ramps at all intersections and crossings. Utilize the [ODOT curb ramp process](#) for upgrading curb ramps.
- d. **Single Function Standard:** Single Function projects are very limited in scope. The feature addressed in a single function project is to use 4R design standards for that specific feature. Design exceptions are not required for non-standard geometric elements not impacted by the single function work. If the sidewalk is not being modified, but the railing is being modified, which reduces the width of the sidewalk below the minimum 4 foot width, a design exception is required. If the reduction in usable sidewalk width retains the minimum 4 foot width, but not the ODOT standard width, a design exception is required for not meeting the ODOT standard.

1.17 SEISMIC DESIGN

[1.17.1 Design Philosophy](#)

[1.17.2 Applications of AASHTO LRFD Bridge Design Specifications](#)

[1.17.3 Applications of AASHTO Guide Specs for LRFD Seismic Bridge Design](#)

[1.17.4 Liquefaction Evaluation and Mitigation Procedures](#)

[1.17.5 Costs](#)

[1.17.6 Instrumentation](#)

[1.17.7 Dynamic Isolators](#)

[1.17.8 Seismic Restrainer Design \(New Designs And Retrofits\)](#)

[1.17.1 Design Philosophy](#)

The 2008 Interim Revisions to the 4th edition of the *AASHTO LRFD Bridge Design Specifications* were developed in late 2007. Though these revisions still support a “force-based” design philosophy, they represent a significant update to many areas of the seismic design provisions in *AASHTO LRFD Bridge Design Specifications*. In 2008, AASHTO also adopted the *Guide Specifications for LRFD Seismic Bridge Design*, a standalone document, which represents a “displacement-base” design philosophy.

Design all bridges for full seismic loading according to the 2nd edition of *AASHTO Guide Specifications for LRFD Seismic Bridge Design (Guide Spec.)*. Obtain approval by the ODOT State Bridge Engineer if the use of *AASHTO LRFD Bridge Design Specifications* is to be considered for any unique project on state-owned bridges.

Comply with ODOT’s additional requirements and guidelines summarized in *BDM 1.17.2* if designing seismically according to *AASHTO LRFD Bridge Design Specifications* or *BDM 1.17.3* if designing seismically according to *AASHTO Guide Specifications for LRFD Seismic Bridge Design*.

Notify and consult ODOT Bridge Section for decisions involving deviations to the standard seismic design practices described in this manual. Deviations from the following guidelines should be justified and documented. The documentation should be in the permanent bridge records.

At the end of the design process, fill in and submit to ODOT Bridge HQ a copy of the [Seismic Design/Retrofit Data Sheet](#).

Seismic load effects should be considered for all projects using the following guidelines:

1.17.2 Applications of AASHTO LRFD Bridge Design Specifications

1.17.2.1 General Considerations

New Bridges: Design all bridge components for full seismic loading according to the current edition of *AASHTO LRFD Bridge Design Specifications*, except as modified by *BDM 1.11.3.5* to *1.11.3.11*, and *1.17.1* to *1.17.8*. Consider the load factor for the Live Load on Extreme Event Load Combination I, $\gamma_{EQ} = 0$ (*LRFD 3.4.1*), unless the bridge is designated by Bridge Section as a major, unusual or unique structure.

The Structural Engineer/Designer should rely on the project Geotechnical Designer to provide the seismic hazards, ground motions, deformations and additional permanent loads.

Design new bridges on or West of US97 for a two-level performance criteria; Life Safety and Operational. Design new bridges east of US97 for the Life Safety criteria only. Seismic Design Criteria for Life Safety and Operational are described below.

“Life Safety” Criteria: Design all bridges for a 1000-year return period earthquake (7% probability of exceedance in 75 years) to meet the “Life Safety” criteria using the 2014 USGS Hazard Maps. The probabilistic hazard maps for an average return period of 1000-year and 500-year are available at [ODOT Bridge Section website](#), but not available on USGS website. To satisfy the “Life Safety” criteria, use Response Modification Factors from *LRFD Table 3.10.7.1-1* using an importance category of “**other**”.

To aid in providing consistency and efficiency, Bridge Section has developed an excel application for constructing the probabilistic response spectrum using the general procedure (three-point curve). Latitude, Longitude, and Site Class are the needed input. Version 2014.16 of this excel application has been released to incorporate the updated Site Coefficients associated with the 2014 hazard maps and can be obtained at the following link:

<https://www.oregon.gov/ODOT/Bridge/Pages/Seismic.aspx>

Replace *LRFD Tables 3.10.3.2-1*, *3.10.3.2-2*, and *3.10.3.2-3* with Tables 1.17.3-1A, 1.17.3-1B, 1.17.3-1C.

“Operational” Criteria: Design all bridges on and West of US97 to remain “Operational” after a full rupture of Cascadia Subduction Zone Earthquake (CSZE). The full rupture CSZE hazard maps are available at the [ODOT Bridge Section website](#). To satisfy the “Operational” criteria, use Response Modification Factors from *LRFD Table 3.10.7.1-1* using an importance category of “**essential**”. When requested in writing by a local agency, the “Operational” criteria for local bridges may be waived.

The CSZE is a deterministic event, and a deterministic Design Response Spectrum must be generated. To allow for consistency and efficiency in design for the CSZE, an application for generating the Design Response Spectra has been developed by Portland State University. Latitude, Longitude, and $V_{s,30}$ are the needed input for running the application. This application can be accessed at the following link:

<https://www.oregon.gov/ODOT/Bridge/Pages/seismic.aspx>

Non-conventional Bridges: *LRFD 3.10.1* states that the seismic provisions of that manual are applicable for conventional bridges. For seismic design of non-conventional bridges, consult with the Seismic Design Standards & Practice Engineer to discuss whether special analysis and design procedures are warranted.

Bridge Widening: Design selected bridge portions for seismic loading as directed by the flowchart shown in *Figure 1.17.2-1A*. Design by the same criteria as for “New Bridges”.

Potential Factors Affecting Seismic Performance of Bridge Widening – The following considerations refer to the flow chart in *Figure 1.17.2-1A*. The consideration number refers to the corresponding numbered decision box on the flow chart.

Consideration 1

- Widening without adding new columns will make a bridge more vulnerable to seismic loads. Clearances for railroads or highways under structures may prevent adding new columns.

Consideration 2

- Widening on both sides will increase the potential for the new portion to be able to resist seismic loads for the full widened structure.
- Widening on one side only may actually result in a completed structure that is more vulnerable than the original structure.
- If widening is on one side only, is there a possibility another future widening could be placed on the opposite side?
- It will not normally be practical for a widening to resist the total seismic load (existing and widening) when widening on only one side; however, there could be exceptions.

Consideration 3

- A formal seismic analysis may be required to answer this question. A “yes” answer to Consideration 3 assumes only minimal work (such as column jacketing) will be needed for the existing structure.
- Although the existing structure may have inadequate capacity, it will have some capacity that can probably be taken advantage of.
- If existing columns are not stressed beyond the elastic range they will probably not need a Phase 2 retrofit.
- The existing structure will have to go through the same deformations as the new portion even though the capacity may not be included in the seismic analysis.

Consideration 4

- Structures which are connected must have compatible deflections at connections.
- We are usually not concerned about the seismic load generated from one structure colliding with an adjacent structure; however, there could be exceptions.
- Providing a joint between the widening and existing structure will probably increase the potential for the new portion to resist seismic loads. If the widening adds enough width for at least two lanes and the longitudinal joint would not be in a travel lane, a joint should be considered.

Consideration 5

- Base isolation is strongly encouraged, especially when bearing replacement is required anyway.
- When footing strengthening is required, Phase 2 will probably not be practical due to the high cost. If cost is the primary decision factor, a realistic estimate of Phase 2 retrofit cost should be prepared. Don't say it costs too much without knowing how much too much is!
- The closer footings are to the ground surface, the more practical Phase 2 will become.

Consideration 6

- If you can't see the new portion acting separately, do not waste time assuming it will!
- Widening with only one new column per bent vs. multiple columns on the existing structure probably do not need to be modeled separately.
- When widening with 2 or more columns or with drilled shafts, it is probably reasonable to model the new structure separately.
- Consider the potential for another future widening. Perhaps size the footings larger than necessary.

Consideration 7

- Is it even possible to close the structure to replace it? Can it be replaced in stages? Is it historic?
- A new structure will usually be far superior to a "band-aided" structure.

Consideration 8

- FHWA requirements take effect when the new structure actually has more travel lanes than the existing structure. Widening that adds only shoulder width or median width is not affected. FHWA requirements may assist in convincing Region of including Phase 2 seismic retrofit, but it is not intended to force a Phase 2 retrofit when it really is not practical.
- For projects exempt from FHWA review, the Technical Services Branch Manager will approve exceptions to FHWA policy.

Consideration 9

- Region holds the money. They may have factors/priorities we don't know about.
- Refusal by Region to fund the needed retrofit and refusal by FHWA to grant an exception (if federal funding) could lead to cancellation of the project.
- It would be desirable to calculate a cost-benefit ratio.

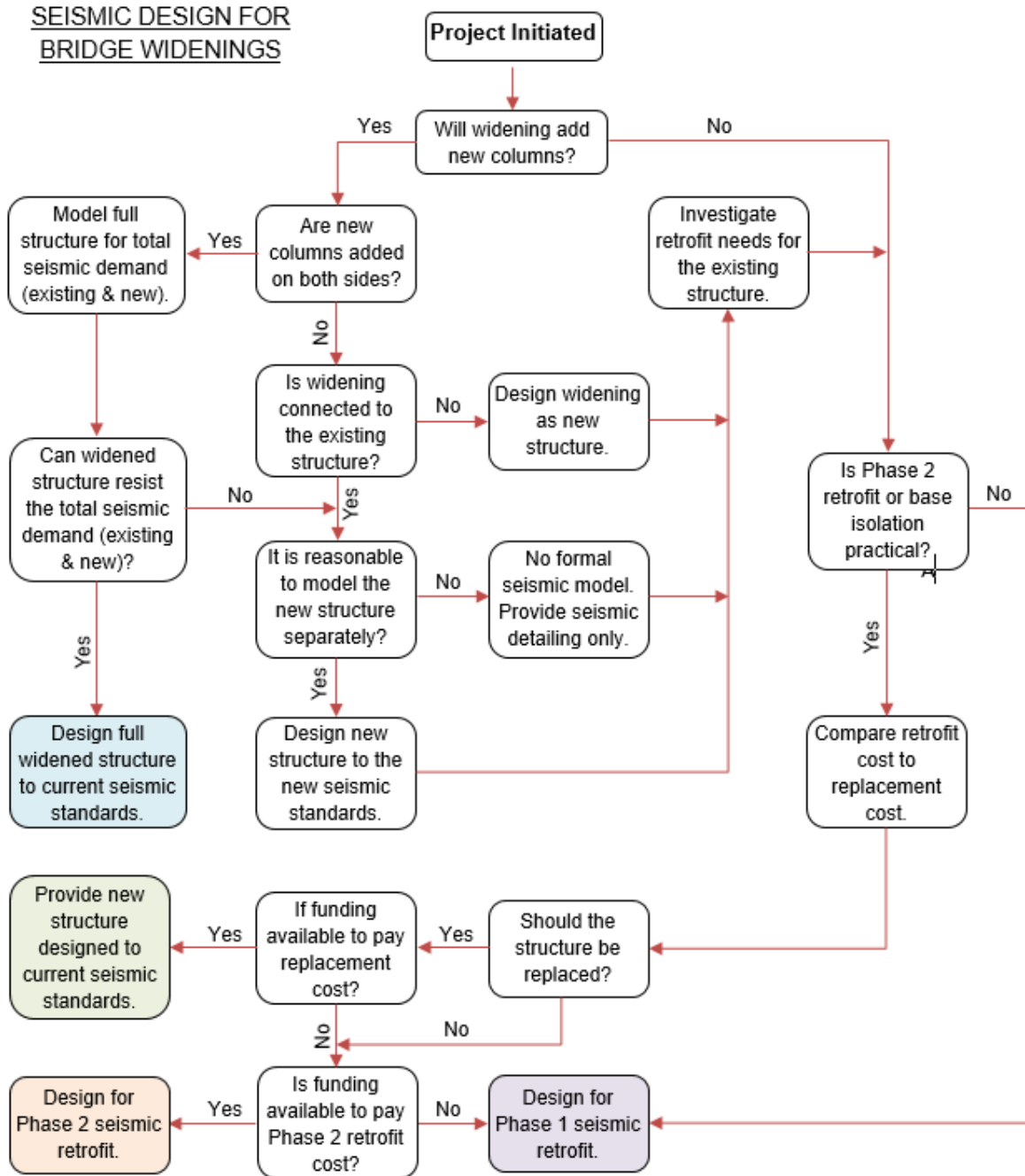

Notes:

1. Document all seismic-related decisions with a memo to the file.
2. The Bridge Section Seismic Committee will be available to assist in the decision process when requested by the designer.
3. The designer should strive for higher levels of seismic design/retrofit whenever practical.
4. See preceding pages for potential factors affecting seismic design decisions.

Figure 1.17.2-1A

Seismic Retrofit: There is currently no funding within ODOT solely to upgrade the seismic load resistance of selected structures. However, when the seismic retrofit design is included in a project, use a phased approach for establishing a practical and economical retrofit strategy. The publication "Seismic Retrofitting Manual for Highway Structures" (FHWA-HRT-06-032) is recommended as a reference source to supplement the Bridge Design Manual and Bridge CAD Manual.

The following steps are provided to help designers initiating the design process:

- Most Oregon bridges fall under importance category of “**standard**”, based on the Bridge Importance Category definitions provided on FHWA-HRT-06-032. Contact Bridge HQ when this category becomes questionable for a given structure.
- Contact Bridge HQ for information on the Anticipated Service Life (ASL) of the bridge.
- Revise the top-half of the Table 1-2 of FHWA-HRT-06-032 with the following:

Table 1.17.2-1A

Minimum performance levels for retrofitted bridges

EARTHQUAKE GROUND MOTION	BRIDGE IMPORTANCE and SERVICE LIFE CATEGORY					
	Standard			Essential		
	ASL 1	ASL 2	ASL 3	ASL 1	ASL 2	ASL 3
Lower Level Ground Motion Cascadia Subduction Zone Earthquake – Full Rupture	PL0 ⁴	PL3 PL2	PL3 PL2	PL0 ⁴	PL3 PL2	PL3
Upper Level Ground Motion 7 percent probability of exceedance in 75 years; return period is about 1,000 years.	PL0 ⁴	PL1	PL1	PL0 ⁴	PL1	PL2

For assessing the seismic performance of existing bridges use the following concrete strain limits for existing bridge columns with poor confinement detailing:

Design Criteria	Confinement Detailing	Inadequate Hoops and Hoop Spacing ¹	
		Inadequate Lap Splice ²	Adequate Lap Splice
Operational		0.002	0.002
Life Safety		0.003	0.004

- 1) As adequate hoops are qualified those that meet the definition of “seismic hooks” in Article 8.8.9 of *AASHTO Guide Specifications for Seismic Bridge Design* and are spaced no more than 6 inches apart.
- 2) As adequate lap splice are qualified those that meet the requirements of Article 5.10.8.4.3a of *AASHTO LRFD Bridge Design Specifications* for Class B splice.

Phase 1

The Phase 1 Seismic Retrofit is considered to achieve “Life Safety” performance of Oregon bridges under seismic induced loading. Work during this phase is intended to prevent superstructure pull-off and bearing failure. This is the nature of almost all our retrofit program at this time.

Incorporate Phase 1 Seismic Retrofit on all bridge projects when bridges are located in Seismic Zone 3 or 4. Bridges located in Seismic Zone 2 may be considered for Seismic Retrofit if situated between bridges (on the same route) that have received or are receiving Seismic Retrofit, or between new bridges built to current seismic design standards.

As a minimum, include at least Phase 1 Retrofit. Assure that the girders will not pull off longitudinally or slide off laterally from the bents. This will normally involve addition of cable restraints, shear blocks, and/or beam seat lengthening and widening.

Identify a seismic design concept which will accomplish the intent to preclude span pull off or collapse of the superstructure. Depending on the concept selected, some strengthening of the superstructure may be required to assure loads generated at the restraints or shear blocks can be transmitted without exceeding design stresses in the superstructure. For steel truss bridges, ensure all truss elements and connections provide sufficient resistance to failure or plastic deformation under seismic induced loading. Short pedestals or secondary columns above the main bent cap level must also be investigated for seismic induced loading and strengthened or braced, if necessary.

Upgrade existing bearings to elastomeric bearings, if needed to assure the designer's concept will work. Upgrading bearings to elastomeric should, also, be considered to improve seismic performance when existing bearings are known to have poor seismic performance, such as steel rocker bearings. Analysis for Phase 1 Retrofit will normally consist of a single degree of freedom model, which may be sufficient for normal bridges. However, a higher level analysis may be required, if needed to fully develop the designer's concept, or for bridges with irregular column lengths of multi-column bents or if the bents have significantly different stiffness. Use full column sections (uncracked) for this level of analysis to develop connection design loads. This is the minimum level of work that must be included. A cracked section analysis may be used to investigate the maximum anticipated movements.

Phase 2

Work during this phase involves substructure (columns, footings and foundations) ductility enhancement and strengthening. Any additional or deferred Phase 1 Retrofit work would also be included. The end product is a retrofitted bridge with as much seismic loading resistance as a new bridge would have for the site. The Phase 2 Seismic Retrofit is considered to achieve the “Operational” performance of Oregon bridges under the seismic loading induced by the full rupture of Cascadia Subduction Zone Earthquake.

Evaluate the structure to investigate the level of effort and scope of work needed to do Phase 2 Retrofit. Phase 2 involves a complete seismic analysis of the widened or rehabilitated bridge for full seismic loading, including consideration of strengthening or restraints to the superstructure, substructure and foundations. The work may involve column and footing strengthening or enlargement, or the use of isolation bearings, and soil improvement, if there is potential for liquefaction. The decision about whether to actually do Phase 2 Retrofit in the project will be made after developing a retrofit concept, rough cost estimate and evaluation of the relative importance of the bridge to the transportation network, in comparison to the estimated cost

and available funding for the project.

The flowchart for seismic design of widenings in *BDM 1.17.2.1 (Figure 1.17.2-1A)* can be used as a guide to make the decision. On major, unusual or border bridges, the decision should involve discussion with Bridge Section, since seismic retrofit criteria for these structures are specific to the site.

A seismic retrofit analysis typically requires the use of a “Site Factor” to develop the response spectrum used in the analysis. Site factors are based on the soil conditions at the site, (categorized as Site Classes A - F) as described in the FHWA Seismic Retrofitting Manual for Highway Structures, Table 1-3. For most normal bridges requiring Phase 1 retrofit work the site class can be determined using either existing soils data or a general knowledge of the site geology and soil conditions. If limited knowledge is available the default designation of Site Class D is acceptable. However, for Phase 2 level retrofit analysis more detailed soils information is required to better determine the design response spectrum and also to adequately characterize and model the foundations in the analysis. Additional exploration work may be required to obtain this information. This additional work is justified due to the increased cost of Phase 2 retrofit work and the need for a more refined analysis.

Rail Upgrade, Deck Overlays, Preservations, Repair, Strengthening, and Others:

These projects should include seismic retrofit as described previously for "Seismic Retrofit".

Temporary Detour Bridges:

Design all temporary detour bridges meeting one of the following criteria according to *LRFD 3.10.10*:

- Bridge is expected to be in service for more than one year and ADT > 10,000
- Bridge is expected to be in service for more than two years

For all other temporary detour bridges, provide the minimum support length requirement according to *LRFD 4.7.4.4*.

1.17.2.2 Specification Interpretations and Modifications

Nomenclature:

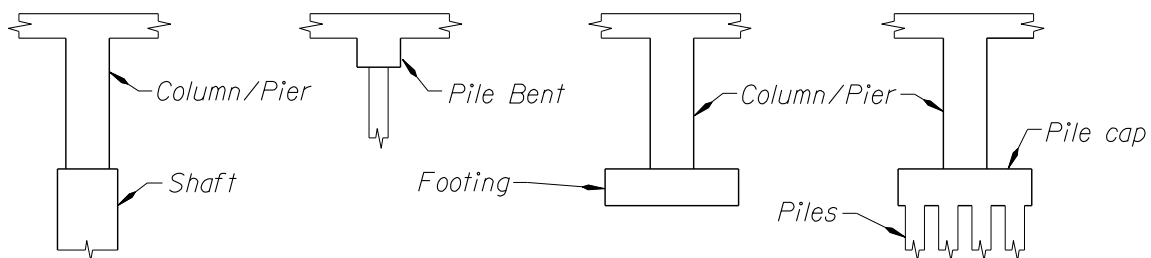

Figure 1.17.2-2A

Response Modification Factors and other Special Items:

All Single Spans:

- No response modification factors -- not applicable.

Bridge Design Manual – June 2020
Oregon Department of Transportation
Section 1 – Design Standards

- Provide for connection force of: "Tributary weight" x "A_s", where A_s = F_{pga}*PGA, or provide the specified minimum support length according to *LRFD 4.7.4.4*.
- Free standing abutments (expansion jointed systems) are to be designed for pseudostatic Mononobe-Okabe method lateral earth forces.

Seismic Zone 1:

- No response modification factors -- not applicable.
- Provide for connection force of:
0.15*F_v, when A_s < 0.05, or
0.25*F_v, when A_s ≥ 0.05, where F_v is the vertical reaction at connection, or
provide the specified minimum support length.

Seismic Zone 2:

- Design and detail Zone 2 structures by Zone 3 and 4 criteria except for the following design provisions:
- When determining the capacity for compression-controlled sections for extreme event limit state use Resistance Factors of Φ=0.75 as specified for Zone 2 in *LRFD 5.5.4.2.1*.
- When designing the reinforcement for compression members, design in accordance with *LRFD 5.7.4.2* "Limits of Reinforcement" for Seismic Zone 2.

Zones 3 and 4:

- Columns and Piers:
 - Moment: R = 2 to 5 (*LRFD Table 3.10.7.1-1*, right column)
 - Shear: R = 1
 - Axial: R = 1

NOTE: The plastic hinging capacity should be determined from column interaction curves with axial and moment Φ values of 1.0. Enter the curve with the unfactored dead load axial force (plus any redundancy induced axial force due to lateral seismic loading), determine the accompanying moment capacity and multiply this value by 1.3. This is the plastic moment capacity.

Foundations:

- Pile Bent: Treat as columns and piers (R=5). Design splices to at least the lesser of 1.3(M_{plastic}) for the portion above or below the splice. This splicing requirement does not apply to full penetration welded splices.

Footing - pile cap - piles:

- Moment, shear & axial: R = 1 (elastic analysis forces) or,
- Moment: Plastic moment capacity of the selected column.
- Shear and Axial: Value accompanying the plastic moment capacity of the column (see "Columns" above).

Other Special Items:

- Confining Reinforcement (plastic hinge zones)
 - Provide transverse reinforcement for confinement in plastic hinging zone to satisfy *LRFD equations 5.7.4.6-1, 5.10.11.4.1d-1, 5.10.11.4.1d-2 and 5.10.11.4.1d-3*.
 - Plastic zone limits are defined as the greatest of maximum column dimension, (column height)/6, or 18 inches.
 - Extend confining reinforcement into footing or crossbeam by the greatest of (maximum column dimension)/2, or 15 inches.
 - Maximum confining reinforcement spacing is the lesser of (the least member dimension)/4, or 4 inches.
 - Shear reinforcing meeting the detailing requirements of confining reinforcement may be considered as part of the required confining reinforcing.

Column Moment Strength Reduction Factor (Φ factor)

- Use $\Phi = 0.9$ on checking the P- Δ Requirements as per *LRFD 4.7.4.5*.

Column Shear Strength Modifications (end regions)

- End region limits are defined as the greatest of maximum column dimension, (column height)/6 or 18 inches.
- If axial stress $> 0.1f'_c$ use V_c as specified in *LRFD 5.8.3*. Vary V_c linearly from normal value to 0 for axial stress between $0.1f'_c$ and 0.

Longitudinal Reinforcement Development

- Provide anchorage development for steel stress $\geq 1.25f_y$.

1.17.2.3 Detailing

(1) Columns:

- For column design and reinforcement practices, see *BDM 1.11.3*.

(2) Footings:

- All footings must have a top mat of bars whether or not uplift is calculated. Extend spirals at least 2 inches into top of the footing. Place the footing top mat immediately below the spiral termination. Place additional spirals below the mat (use a 6 inch spiral gap) as needed to meet the confining reinforcement layout of *BDM 1.11.3.11*. Use the same spiral pitch at all locations. See the optional detail for alternate containment reinforcing in the column to footing connection in *BDM 1.11.3.10*.
- Note the allowable reduction in reinforcement development length for bars enclosed within a spiral (*LRFD 5.11.2.1.3*).

(3) Crossbeams:

- For column to crossbeam connections where plastic moment capacity is required, provide spirals extending into the crossbeam in the same general manner as described above for the column-to-footing connection.

1.17.2.4 Structure Modeling

(1) Structure Modeling, General:

- Use a "first cut" analysis with fixed supports. These results will be easier to interpret than a spring supported model and will give a baseline for comparison with additional analyses. With these results, make a rough substructure design. Now a new analysis can be performed with footing springs and the substructure design checked and refined. Additional cycles of redesign, analysis, and force comparison to previous analyses could be used in some cases but generally would not be required or warranted.
- A reasonable target for a seismic design check is 20 percent. Designer and Checker should resolve differences greater than 20 percent, but it is impractical to try to refine the design beyond that.

(2) Footing Springs:

- See *BDM 1.10.4*.

(3) Programs:

- The Uniform Load and single mode dynamic analysis methods are acceptable for many structures (see the code limitations) but multi-mode dynamic analysis by computer may be easier. The result of any analysis method must be judged for correctness. Is the result reasonable? Reviewing the calculated periods, modal participation factors and mode shapes can greatly aid this judgment. A high level of engineering judgment will be required at all times.
- MIDAS and GTStrudl are ODOT's primary in-house static and dynamic analysis programs, and are available for bridge designers working at Bridge HQ or Region Tech Centers. Many design firms have adopted the use of SAP2000 or STAAD for seismic design of bridges. Other programs are also acceptable, provided the programs satisfy the analysis requirements and have been previously verified.

(4) Sample Problems:

- Sample problems are shown in the Bridge Example Design notebook, and can be downloaded under [Seismic Design Examples](#).

1.17.2.5 Footing/Pile Cap Design

(1) Piling:

- Nominal pile resistances should be used with the seismic load case (*LRFD Table 3.4.1-1*, Extreme Event-I) to determine pile requirements. Uplift resistance may be used for friction piles if the piles are properly anchored. Consult with the Geotechnical designer for site specific values. Piles under tension that are not capable of resisting uplift should be neglected during analysis for seismic loadings. The remaining piles must provide sufficient support and stability.

(2) Reinforcing Steel:

- Control of cracking requirements of *LRFD 5.7.3.4* do not apply to seismic load cases.
- Pile supported footings should normally have the bottom mat reinforcing above the pile tops. Footings with this scheme are preferable to thinner footings with the bottom mat detailed lower (between the piling). This is for constructability.

1.17.3 Applications of AASHTO Guide Specs for LRFD Seismic Bridge Design

1.17.3.1 General Considerations

As of 2009, ODOT has fully adopted the use of *AASHTO Guide Specifications for LRFD Seismic Bridge Design* for designing Oregon bridges subjected to earthquake loading. The following summarizes ODOT's additional requirements and deviations from the *AASHTO Guide Specifications for LRFD Seismic Bridge Design*.

Design all bridge components for full seismic loading according to the 2nd edition of *AASHTO Guide Specifications for LRFD Seismic Bridge Design (Guide Spec.)*, except as modified by *BDM 1.11.3.5* to *1.11.3.11*, and *1.17.1* to *1.17.8*. Consider the load factor for the Live Load on Extreme Event Load Combination I, $\gamma_{EQ} = 0$, unless the bridge is designated by Bridge Section as a major, unusual or unique structure.

The Structural Engineer/Designer should rely on the project Geotechnical Designer to provide the seismic hazards, ground motions, deformations and additional permanent loads.

Design new bridges on or West of US97 for a two-level performance criteria; Life Safety and Operational. Design new bridges east of US97 for the Life Safety criteria only. Seismic Design Criteria for Life Safety and Operational are described below.

"Life Safety" Criteria: Design all bridges for a 1000-year return period earthquake (7 percent probability of exceedance in 75 years) to meet the "Life Safety" criteria using the 2014 USGS Hazard Maps. The probabilistic hazard maps for an average return period of 1000-year and 500-year are available at [ODOT Bridge Section website](#), but not available on USGS website.

To aid in providing consistency and efficiency, Bridge Section has developed an excel application for constructing the probabilistic response spectrum using the general procedure (three-point curve). Latitude, Longitude, and Site Class are the needed input. Version 2014.16 of this excel application has been released to incorporate the updated Site Coefficients associated with the 2014 hazard maps and can be obtained at the following link:

<https://www.oregon.gov/ODOT/Bridge/Pages/seismic.aspx>

To satisfy the "Life Safety" criteria, comply with the following requirements and guidelines:

Seismic Design Categories (SDC) A, B and C

- Meet all design requirements for SDC A, B and C according to the *AASHTO Guide Specifications for LRFD Seismic Bridge Design*.

Seismic Design Category (SDC) D

- Meet all design requirements for SDC D according to the *AASHTO Guide Specifications for LRFD Seismic Bridge Design*, except as modified below:
 - The maximum concrete strain in confined section of the columns (ϵ_{cc}) does not exceed 90% of the ultimate concrete strain (ϵ_{cu}), computed by Mander's model.
 - The maximum strain of reinforcing steel does not exceed the ϵ_{su}^R as defined on Table 8.4.2-1 of the AASHTO Guide Spec.
 - The maximum strain of prestressing steel does not exceed $\epsilon_{ps,u}^R = 0.03$

The above guidelines are applicable even for the other Seismic Design Categories, if Pushover Analysis will be used instead of the implicit equation.

Replace *AASHTO Guide Spec Table 3.4.2.3-1* with two following tables:

Table 1.17.3-1A

Values of Site Factor, F_{pga} , at Zero-Period on Acceleration Spectrum

Site Class	Mapped Peak Ground Acceleration Coefficient (PGA) ¹					
	PGA ≤ 0.1	PGA = 0.2	PGA = 0.3	PGA = 0.4	PGA = 0.5	PGA ≥ 0.6
A	0.8	0.8	0.8	0.8	0.8	0.8
B	0.9	0.9	0.9	0.9	0.9	0.9
C	1.3	1.2	1.2	1.2	1.2	1.2
D	1.6	1.4	1.3	1.2	1.1	1.1
E	2.4	1.9	1.6	1.4	1.2	1.1
F ²	*2	*2	*2	*2	*2	*2

Table 1.17.3-1B

Values of Site Factor, F_a , for Short-Period Range of Acceleration Spectrum

Site Class	Mapped Spectral Acceleration Coefficient at Period 0.2 sec (S_s) ¹					
	$S_s \leq 0.25$	$S_s = 0.5$	$S_s = 0.75$	$S_s = 1.0$	$S_s = 1.25$	$S_s \geq 1.5$
A	0.8	0.8	0.8	0.8	0.8	0.8
B	0.9	0.9	0.9	0.9	0.9	0.9
C	1.3	1.3	1.2	1.2	1.2	1.2
D	1.6	1.4	1.2	1.1	1.0	1.0
E ³	2.4	1.7	1.3	*3	*3	*3
F ²	*2	*2	*2	*2	*2	*2

Replace *AASHTO Guide Spec Table 3.4.2.3-2* with following table:

Table 1.17.3-1C

Values of Site Factor, F_v , for Long-Period Range of Acceleration Spectrum

Site Class	Mapped Spectral Response Acceleration Coefficient at Period 1.0 sec (S_1) ¹					
	$S_1 \leq 0.1$	$S_1 = 0.2$	$S_1 = 0.3$	$S_1 = 0.4$	$S_1 = 0.5$	$S_1 \geq 0.6$
A	0.8	0.8	0.8	0.8	0.8	0.8
B	0.8	0.8	0.8	0.8	0.8	0.8
C	1.5	1.5	1.5	1.5	1.5	1.4
D ³	2.4	2.2 ³	2.0 ³	1.9 ³	1.8 ³	1.7 ³
E ³	4.2	3.3 ³	2.8 ³	2.4 ³	2.2 ³	2.0 ³
F ²	*2	*2	*2	*2	*2	*2

Notes:

¹ – Use straight-line interpolation for intermediate values of PGA, S_s , or S_1 .

² – Perform a site-specific geotechnical investigation and dynamic site response analysis for all multi-span bridges in Site Class F.

³ – Consider performing a ground motion hazard analysis and/or dynamic site response analysis for multi-span bridges.

“Operational” Criteria: Design all bridges on and West of US97 to remain “Operational” after a full rupture of Cascadia Subduction Zone Earthquake (CSZE). The full rupture CSZE hazard maps are available at the [ODOT Bridge Section website](#).

The CSZE is a deterministic event, and a deterministic Design Response Spectrum must be generated. To allow for consistency and efficiency in design for the CSZE, an application for generating the Design Response Spectra has been developed by Portland State University. Latitude, Longitude, and $V_{s,30}$ are the needed input for running the application. This application can be accessed at the following link:

<https://www.oregon.gov/ODOT/Bridge/Pages/Seismic.aspx>

To satisfy the “Operational” criteria, comply with the following requirements and guidelines:

Seismic Design Categories (SDC) A, B, C and D

- Verify the “Operational” performance for Cascadia Subduction Zone Earthquake when potentially liquefiable soils are present on site.

Seismic Design Categories (SDC) A and B

- No structural analysis is required for “Operational” criteria.

Seismic Design Category (SDC) C

- Satisfy *equation 4.8-1* of the AASHTO Guide Spec ($\Delta^L_D < \Delta^L_C$) for each bridge bent, where Δ^L_C is determined from the *equation 4.8.1.1* of the AASHTO Guide Spec (displacement capacity for SDC B).

Seismic Design Category (SDC) D

- Meet all design requirements for SDC D according to the *AASHTO Guide Specifications for LRFD Seismic Bridge Design*, except as modified below:
 - Ensure the maximum concrete strain in confined section of the columns does not exceed $\epsilon_{cc} = 0.005$
 - Ensure the maximum strain of reinforcing steel does not exceed $2*\epsilon_{sh}$, where ϵ_{sh} is defined on *Table 8.4.2-1* of the AASHTO Guide Spec.
 - Ensure the maximum strain of prestressing steel (for 270 ksi strands) does not exceed $\epsilon_{ps,EE} = 0.0086$

Non-conventional Bridges: *Guide Spec. 3.1* states that the seismic provisions of this Manual are applicable for conventional bridges. For seismic design of non-conventional bridges, consult with the Seismic Design Standards & Practice Engineer to discuss whether special analysis and design procedures are warranted.

Pedestrian Bridges: *Guide Spec. 3.6* states that pedestrian bridges over roads carrying vehicular traffic shall satisfy the performance criteria defined for other highway bridges. Design new pedestrian bridges over roads carrying vehicular traffic per the requirements of this section. However, pedestrian bridges that do not cross roads carrying vehicular traffic do not need be designed for the “Operational” Criteria.

Buried Structures: According to *Guide Spec. 3.1*, buried structures, generally, do not need be designed for seismic loads. However, for all buried structures supported on piling or drilled shafts type foundations, design the structure for seismic loading as required by this section.

1.17.3.2 Specification Interpretations and Modifications

The following items summarize ODOT’s additional requirements and deviations from *AASHTO Guide Specifications for LRFD Seismic Bridge Design*:

- Design all bridges to satisfy the Type-1 Global Seismic Design Strategy (ductile substructure with essentially elastic superstructure), *Guide Spec. 3.3*. However, in case of a steel substructure, design the bridge according to the latest edition of the *AASHTO LRFD Bridge Design Specifications*.

Type-2 Global Seismic Design Strategy (essentially elastic substructure with ductile superstructure) is not permitted by ODOT.

Type-3 Global Seismic Design Strategy (elastic superstructure and substructure with a fusing mechanism between the two) can be considered if approved by the State Bridge Engineer. Include a clear description of the selected Seismic Design Strategy in the appropriate Calculation Book for the structure.

- The following types of Earthquake Resisting Systems (ERS) or Earthquake Resisting Elements (ERE) provided in *Guide Spec. 3.3* are permissible ERS or ERE for ODOT bridges:
 - Type 1, 2, 3, 4 and 5 on *Figure 3.3-1a*
 - Types 1, 2, 3, 7, 8, 9, 10, 11*, 12 and 14 on *Figure 3.3-1b*

* To use this Earthquake Restraining Element the following must be applied:

1. Liquefaction induced-lateral spread and slope instability are deemed unlikely to occur under the design earthquake.
2. For the Life Safety criteria a maximum of 70% of the passive abutment resistance can be used in seismic analyses in accordance with AASHTO Guide Spec.
3. For the Operational criteria a maximum of 30% of the passive abutment resistance can be used in seismic analyses.

Bridge Design Manual – June 2020
Oregon Department of Transportation
Section 1 – Design Standards

- Obtain approval from the State Bridge Engineer before considering the application of the following types of Earthquake Resisting Systems (ERS) or Earthquake Resisting Elements (ERE) provided in *Guide Spec. 3.3*:
 - Type 6 on *Figure 3.3-1a*
 - Types 4, 5, and 6 on *Figure 3.3-1b*
 - Types 1 and 2 on *Figure 3.3-2*
 - The following types of Earthquake Resisting Systems (ERS) or Earthquake Resisting Elements (ERE) provided in *Guide Spec. 3.3* are not permissible ERS or ERE for ODOT bridges:
 - Type 13 on *Figure 3.3-1b*
 - Types 3, 4, 5, 6, 7, 8 and 9 on *Figure 3.3-2*
 - Types 1, 2, 3 and 4 on *Figure 3.3-3*
 - Identify the ERS for bridges in SDC B (*Guide Spec. 3.5*) when $0.25 \leq S_{D1} < 0.30$.
 - Pushover analysis can be used instead of the implicit equations to determine the Displacement Capacity for SDC B and C as prescribed on *Guide Spec. 3.5*. When pushover analysis is performed, provide SDC D Level of Detailing regardless of the design SDC.
 - Satisfy the balanced stiffness and balanced frame geometry requirements for all bridges in SDC C and D (*Guide Spec. 4.1.2* and *4.1.3*).
 - Use Procedure Number 2 (Elastic Dynamic Analysis) to determine seismic designs for all bridges with two or more spans (*Guide Spec. 4.2*).
 - Use Procedure 3, (Nonlinear Time History Analysis) if the Geotechnical Engineer is performing a site-specific hazard motion analysis and any of the following exists:
 - The maximum bridge span length is more than 300 feet or the total bridge length is more than 1,800 feet
 - Bridge geometry does not allow for the balanced stiffness or balanced frame geometry requirements be satisfied
 - Special bearing and damping devices (isolation bearing, shock transmission units, etc.) and non-conventional expansion joints are expected to be installedNonlinear Time History Analysis is the most expensive seismic analysis procedure; however, the extra design cost is often offset by construction cost savings and can be effectively used to manage risk.
- Consult the project Geotechnical Engineer to determine if there are geotechnical factors that may lead to pursuing the development of ground response and non-linear time history analyses. Some of these could include:
- Bridge is within 6 miles of an active fault
 - Soils at bridge site are defined as Site Class “E” or “F” soils
 - Soil profile supporting the bridge varies significantly among bridge bents
- Use a Damping Ratio of 5 percent (*Guide Spec. 4.3.2*) on all new bridges for seismic loading. The application of the reduction factor, R_D , is not allowed without approval from the State Bridge Engineer.
 - Use Design Method 3 (Limited-Ductility Response in Concert with Added Protective Systems) for designing the lateral seismic displacement demand (*Guide Spec. 4.7.1*) only upon approval from the State Bridge Engineer.
 - Design Longitudinal Restrainers (*Guide Spec. 4.13.1*) in accordance with *BDM 1.17.8*.

Bridge Design Manual – June 2020
Oregon Department of Transportation
Section 1 – Design Standards

- Participation of the end panel, wingwalls, and backwalls in the overall dynamic response of bridge systems may be considered in seismic design of bridges using *BDM 1.10.4.2*.
- Select the Foundation Modeling Method (FMM) (*Guide Spec. 5.3.1*) according to *BDM 1.10.4*. Do not allow uplift or rocking of spread footings in all SDCs.
- Perform Liquefaction Assessment for all bridge sites according to *Chapter 6* of the ODOT Geotechnical Design Manual.
- Use the provisions in *Guide Spec. 7.2* in conjunction with the forced-based seismic design procedure utilized in the *AASHTO LRFD Bridge Design Specification* and requirements of this section of the BDM.
- Provide minimum shear reinforcement for bridges in SDC A, when $0.10 \leq SD1 \leq 0.15$, according to the requirements of *Guide Spec. 8.6.5* for SDC B, in addition of satisfying the requirements of *Guide Spec. 8.2*.
- Do not use wire rope or strands for spirals, and high strength bars with yield strength exceeding 75 ksi. Deformed welded wire fabric (*Guide Spec. 8.4.1*) may be used with approval from the State Bridge Engineer.
- The same size vertical bars may be used inside and outside of interlocking spirals (*Guide Spec. 8.6.7*).
- Provide minimum longitudinal reinforcement (*Guide Spec. 8.8.2*) of 1 percent for columns in SDC B, C and D.
- Extend the vertical column bars into oversized drilled shaft according to *BDM 1.10.5.5*, in lieu of *Guide Spec. 8.8.10*.
- Revise the third bullet of *Guide Spec. 8.13.4.1.1* as follows:
 - Exterior column joints for box girder superstructures and other superstructure types if the cap beam extends beyond the joint far enough to develop the longitudinal cap reinforcement.

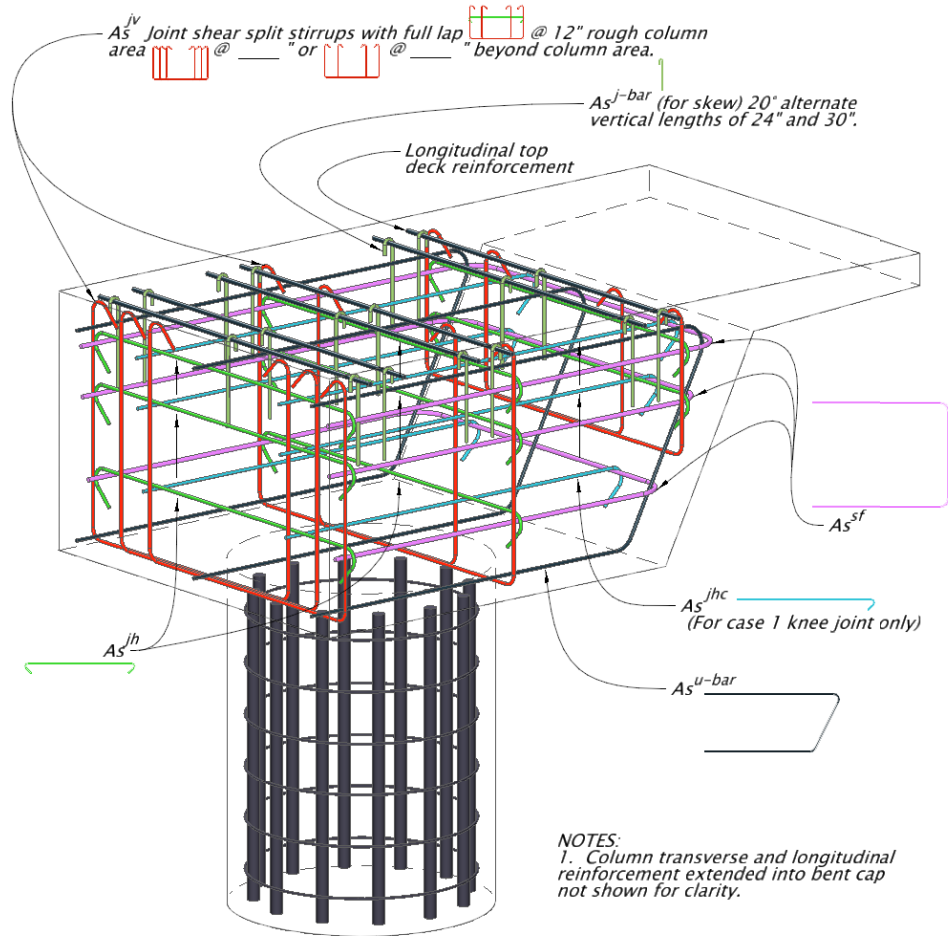

1.17.4 Liquefaction Evaluation and Mitigation Procedures

- The liquefaction potential of foundation soils will be determined by the Geotechnical designer. If foundation soils are predicted to liquefy, the effects of liquefaction on foundation design and performance will be provided as described in *BDM 1.10.5*. The need for liquefaction mitigation will be in accordance with the following ODOT Liquefaction Mitigation Policy.

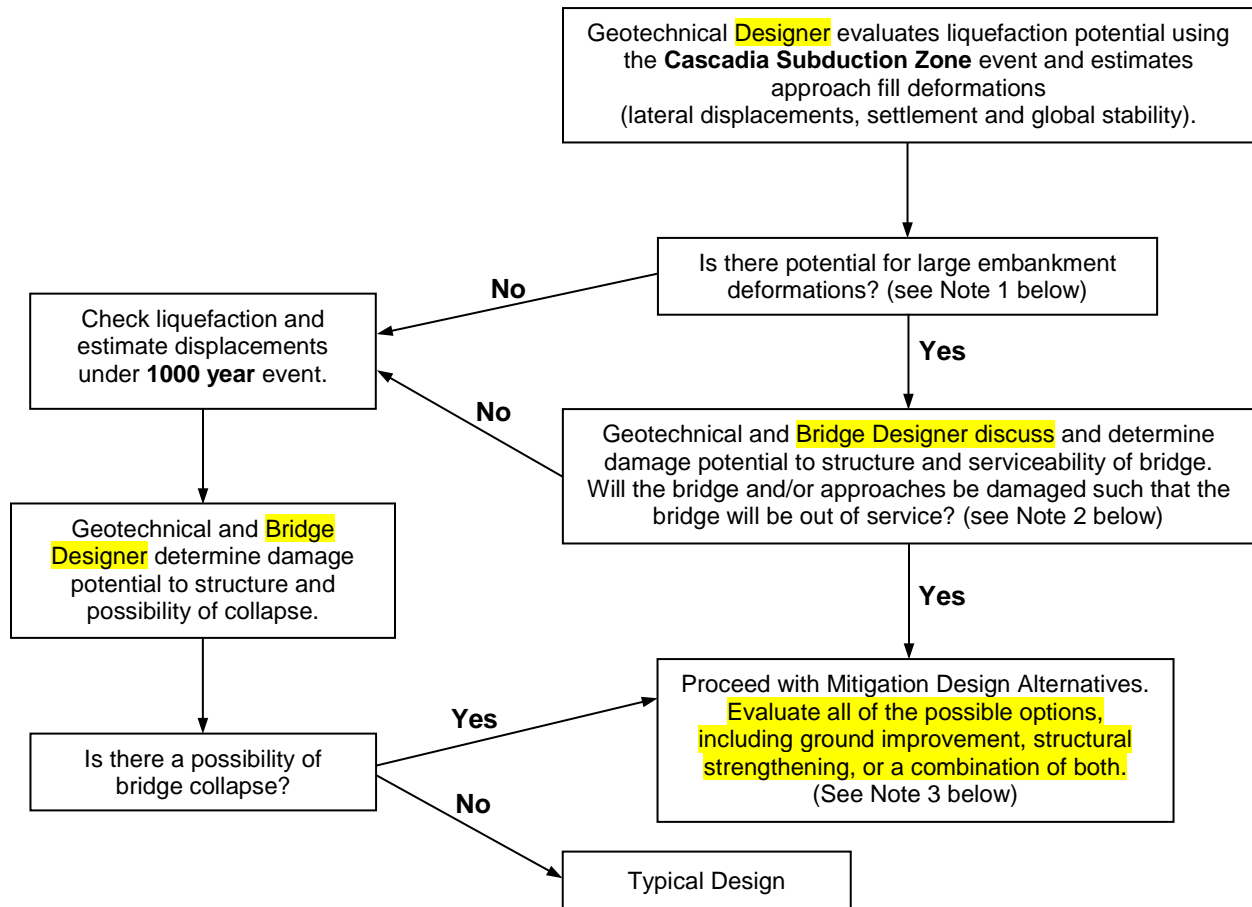

Note 1: For meeting the performance requirements of the Cascadia Subduction Zone event (Operational), lateral deformation of approach fills of up to 12 inches are generally considered acceptable under most circumstances pending an evaluation of this amount of lateral deformation on abutment piling and abutment/cap. Larger structural lateral deformations and settlements may be acceptable under the 1000 year event as long as the “Life Safety” criteria are met.

Note 2: The bridge should be open to emergency vehicles after the Cascadia Subduction Zone event, following a thorough inspection. If the estimated embankment deformations (vertical or horizontal or both) are sufficient enough to cause concerns regarding the serviceability of the bridge, mitigation is recommended.

Note 3: Geotechnical and Bridge Designer to submit all liquefaction mitigation designs and cost estimates to Bridge Standards for review and approval.

A continuous discussion between the Geotechnical and Bridge Designers is to be expected for determining the most cost-effective mitigation alternative. The iteration for both geotechnical and structural analyses start with the Geotechnical Designer providing the Bridge Designer the following information:

- lateral soil displacement,
- vertical soil displacements,
- vertical and horizontal loading on piling and/or end bent due to the soil displacement

Bridge Designer determines the lateral and vertical deformation demand and capacity of the bridge foundation and follows up with the Geotechnical Designer on the need for soil mitigation. Evaluation of the mitigation alternatives should consider both structural improvements and soil mitigation by maintaining a cost balance and equal risk between these two forms of mitigation. Final cost estimates should reflect this evaluation.

Bridge Design Manual – June 2020
Oregon Department of Transportation
Section 1 – Design Standards

Refer to ODOT research report SPR Project 361: "Assessment and Mitigation of Liquefaction Hazards to Bridge Approach Embankments in Oregon", Nov. 2002 and "Ground Modification Methods Reference Manual, Volume I & Volume II", (Pub. No. FHWA-NHI-16-027 & NHI-16-028) for mitigation alternatives and design procedures.

As a general guideline, the foundation mitigation should extend from the toe of the bridge end slope (or face of abutment wall) to a point that is located at the base of a 1:1 slope which starts at the end of the bridge end panel:

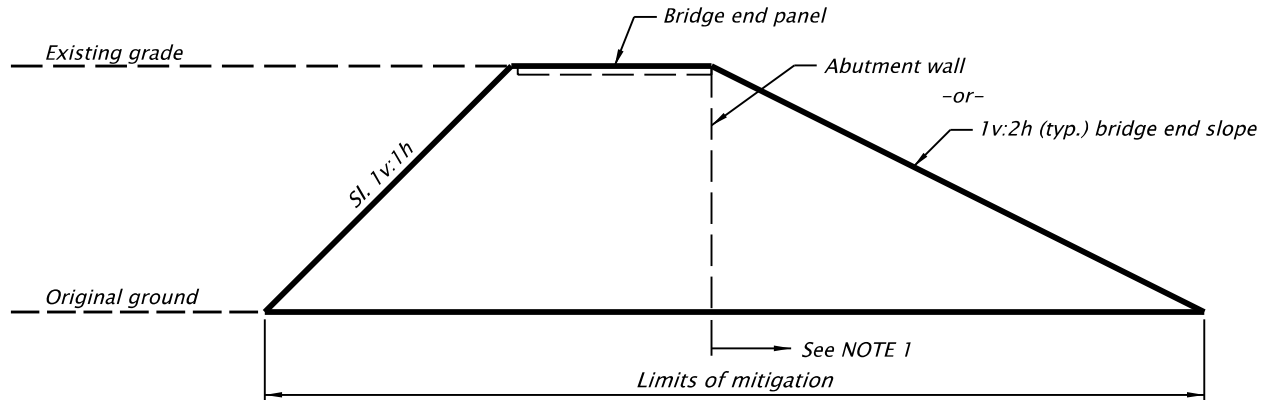

NOTE 1: Extend ground improvement beyond the abutment face as needed for design.

1.17.5 Costs

(1) Construction costs:- Apply the following factors to TS&L (preliminary) structure cost estimates to approximate the additional cost of seismic criteria (excluding liquefaction):

- Single Spans: 1.00
- Multiple Spans: 1.30 Irregular (widely varying columns lengths or support materials; unusual geometry or curvature)
- 1.10 Other

(2) Design costs:- Apply the following factors to TS&L (preliminary) design cost estimates to approximate the additional cost of seismic design criteria (excluding liquefaction):

- Single Spans: 1.00
- Multiple Spans: 1.20 Trestles
1.50 Irregular (widely varying columns lengths or support materials; unusual geometry or curvature)
1.35 Other

1.17.6 Instrumentation

Consider placement of accelerometers on the ground and on structure portions for large or unusual structures. Consult with the State Bridge Engineer to determine if this is appropriate and fits with the ODOT Strong Motion Program.

1.17.7 Dynamic Isolators

Isolators may be useful for either new construction or retrofit work. Isolators change structure response by

lengthening the periods of primary vibration. This tunes the structure response away from the typical earthquake's maximum response frequencies. This effect, along with added damping, works to reduce the system response. The result is reduced substructure forces.

Typical steps to model an isolated structure include:

1. Compute service loads (D, L, LF, CF, W, WL, R, S and T) for the worst single girder.
2. Use these loads, and the applicable seismic loading, in the Dynamic Isolation System, Inc. (DIS) program PC-LEADER to get a preliminary isolator size and its properties. DIS has given us permission to use the program even though we will not specify only their bearing.
3. Develop a full structural model (superstructure, substructure, and bearings/isolators). Normally this will be done on a per girder basis so the substructure should be proportioned to fit this basis. The model can often be a two dimensional model.
4. In the structural model use the equivalent isolator stiffness (K_{eff}). This stiffness should be further modified to fit modeling assumptions of a bearing cantilevered from the substructure at interior supports.
5. Load the structural model with dynamic loading through a modified response spectrum. The response spectrum can be taken from the PC-LEADER output or developed from the Guide Specification for Seismic Isolation Design.
6. Develop another full structural model to represent the "as-is" structure. Dynamically load this model with a normal response spectrum. This gives a basis to evaluate the isolation effectiveness.
7. It may be necessary or desirable to adjust the relative isolator stiffness to better distribute the dynamic forces. It is important the final isolator properties function adequately for service loads. The isolator characteristics must also be realistic and achievable.

An example isolator modeling is given in the Bridge Example Design notebook.

Other computer programs are acceptable, provided the programs satisfy the analysis requirements and have been previously verified.

1.17.8 Seismic Restrainer Design (New Designs and Retrofits)

1.17.8.1 Seismic Restrainer Design, General

The intent is to prevent superstructure pull-off and bearing failure. Work restrainers only in the elastic range. Design the restrainer connection for 125 percent of the restrainer design force.

Note that *LRFD 3.10.9.5* requires "sufficient slack" so that the restrainer does not start to act until the design displacement is exceeded.

Restrainers may be omitted where the available seat width meets or exceeds "N" of the Design Specifications and 4 times the calculated design earthquake elastic deflection. Seat widths meeting these criteria are presumed to accommodate the large elasto-plastic movements of a real structure under seismic loading.

Design restrainers for a minimum force equal to the peak site bedrock acceleration coefficient "A" times the weight of the lighter portion being connected.

In all instances it is necessary to design or check the transfer mechanism for force transfer from superstructure to substructure (bearings, diaphragms).

1.17.8.2 Information for Restrainer Design

(1) Concrete:

Concrete bearing strength based on $0.85f'_c$ ($\Phi = 1.0$).
Maximum increase for supporting surface wider than loaded area = 2.0.
Multiply by 0.75 when loaded area is subject to high edge stresses.

For concrete shear lugs, use *LRFD equation 5.8.4.1-1* for shear friction as outlined in *LRFD 5.8.4*.

(2) Structural Steel:

Design structural steel members using the AASHTO *LRFD Bridge Design Specifications*.

(3) Fasteners:

(Steel to Steel)

		A 307		A 325	
Diameter	Nominal Area (in ²)	Tension (0.76 x 60 ksi)	Shear (0.38 x 60 ksi)	Tension (0.76 x 120 ksi)	Shear (0.38 x 120 ksi)
0.75"	0.4418	20.1 k	10.1 k	40.3 k	20.1 k
0.875"	0.6013	27.4 k	13.7 k	54.8 k	27.4 k
1.0"	0.7854	35.8 k	17.9 k	71.6 k	35.8 k

Note: Tension loads are based on *LRFD equation 6.13.2.10.2-1*.

Shear loads are based on *LRFD equation 6.13.2.7-2* assuming one shear plane per bolt and with threads included in the shear plane.

Shear loads may be increased 25% if the threads are excluded from the shear plane.

(4) Steel Rods:

		A307 Fu = 58 ksi	A449 Fu varies	
Diameter	Stress Area (in ²)	Tension (kips) Ft=Fy=36 ksi	Tension (kips) Ft = Fy	Fy (ksi)
0.750	0.334	12.0	30.7	92
0.875	0.462	16.6	42.5	
1.00	0.606	21.8	55.8	
1.125	0.763	27.5	61.8	81
1.250	0.969	34.9	78.5	
1.375	1.155	41.6	93.9	
1.500	1.405	50.6	114.0	
1.750	1.900	68.4	110.0	58
2.250	2.500	90.0	145.0	

Tensioning of A 449 steel rods must be specified, if required by the design.

Tensioning requirements are not part of the specification as they are with A 325.
Use nominal area for elongation calculations.

(5) Wire Rope:

See *BDM 1.21* for a complete discussion of Structural Wire Rope, Wire Rope Connections & Turnbuckles.

$$F_t = (0.95)(176.1 \text{ ksi})(\text{area}) = 0.95(\text{minimum breaking strength}).$$

Note: Yield strength is approximately equal to minimum breaking strength.

Diameter (in)	Area (in ²)	Minimum Breaking Strength (kips)	Design Load (kips)
1/2	0.119	23.9	22.7
3/4	0.268	52.9	50.2
7/8	0.361	71.6	68.0
1	0.471	93.0	88.3
1 3/8	0.906	173.0	164.0

The area values above are based on ASTM A603. The minimum breaking strength above is based on ASTM A1023. The design load above is based on 0.95 x the minimum breaking strength. For sizes other than 7/8 inch diameter, ASTM A1023 is likely to be used.

E for wire rope = 10,000 ksi

f_y for wire rope = 176.1 ksi

ASTM A603 lists the E for structural wire rope as 20,000 ksi for "prestretched" wire rope. Wire rope used for seismic applications will not be prestretched, however, so an E of 10,000 ksi should be used.

(6) Resin Bonded Anchors:

See *BDM 1.20.2*, "Drilled Concrete Anchors"

(7) Concrete Inserts:

Use hot-dip galvanized expanded coil concrete inserts with closed-back ferrule threaded to receive UNC threaded bolts.

Inserts are readily available in 1/4 inch sizes. Other sizes are only available in very large quantities. Therefore, only the standard sizes listed below are recommended.

Diameter (in)	Tension (kips) A307 or A325	Shear (kips)	
		A307	A325
3/4	12.6	7.4	12.6
1	19.3	13.4	19.3
1-1/4	34.4	21.4	34.4
1-1/2	54.3	31.0	54.3

Tension and shear capacity for concrete failure is based on equation 6.5.2 from the *PCI Design Handbook* (3rd Edition) with $\Phi = 1.0$ and with a factor of safety of 1.5. Equation 6.5.2 controls both shear and tension for shallow embedment depths. See the *PCI Design Handbook* for group effects, edge distance effects and combined tension and shear.

Tension capacity of the insert cannot exceed the tension capacity of the bolt. Shear capacity of the insert cannot exceed the shear capacity of the bolt or the insert tension capacity.

Tension capacity of the bolt = $0.76A_b f_{ub}$, where A_b = bolt stress area (*LRFD equation 6.13.2.10.2-1*).
Shear capacity of the bolt = $0.38A_b f_{ub}$ (*LRFD equation 6.13.2.7-2*).

1.17.8.3 Longitudinal Restrainer Design

(1) In-span hinges: Use the following general procedure (a modified CALTRANS method):

- Estimate restrainers to use (with elongation) and gapping desired/allowed.
- Determine joint openings (including approximate temperature movement (fall) and creep and shrinkage if appropriate).
- Determine frame stiffness and capacity.
- Determine adjacent frame stiffness and capacity.
- Plot force/deflection relationship considering component stiffnesses, joint openings (including temperature, creep, and shrinkage openings), and restrainer gapping.
- Assume a final force and deflection under single-mode response to get equivalent stiffness.
- Calculate period and resulting response coefficient.
- Calculate dynamic force and locate on the force/deflection curve.
- Review that the force capacity of the system is not exceeded, the assumed/acceptable deflection is not exceeded, and the equivalent stiffness and period are approximately as before.
- If checks are not okay modify system and recycle through as needed.

(2) Bents with superstructure continuous over the bent:

- Connect superstructure to substructure with capacity to form plastic hinging in the column(s).

(3) Bents with only the deck continuous over the bent:

- Connect each span to substructure to form plastic hinging in the column(s).

(4) Bents with no superstructure continuity over the bent:

- With frames each side of bent:
Connect each span to substructure to form plastic hinging in the column(s). Also connect adjacent superstructure portions by the same techniques as “in-span hinges.” The adjacent super-structure portions may be connected by span to substructure connections of adequate capacity to function for both portions.
- With simple spans each side of bent:
Connect each span to the substructure to form plastic hinging in the column(s).

NOTE: The plastic hinging capacity should be determined from column interaction curves with axial and moment Φ values of 1.0. Enter the curve with the unfactored dead load axial force (plus any redundancy induced axial force due to lateral seismic loading), determine the accompanying moment capacity and multiply this value by 1.3. This is the plastic moment capacity.

1.17.8.4 Transverse Restrainer Design

(1) In-span hinges:

- Design for force transfer of 2.5(A)(supported dead load).

(2) Bents with superstructure continuous over the bent:

- Connect supported spans with force to form a failure mechanism (plastic hinging at the top of frame (column or crossbeam) and plastic hinging at bottom of column).

(3) Bents with only the deck continuous over the bent:

- Connect supported spans with force to form a failure mechanism (plastic hinging at the top of frame (column or crossbeam) and plastic hinging at bottom of column).
- Prorate design force to ahead and back side of bent by dead load ratio.

(4) Bents with no superstructure continuity over the bent:

- Connect supported spans with a force equal to 2.5(A)(supported dead load).

NOTE: The plastic hinging capacity should be determined from column interaction curves with axial and moment Φ values of 1.0. Enter the curve with the unfactored dead load axial force (plus any redundancy induced axial force due to lateral seismic loading), determine the accompanying moment capacity and multiply this value by 1.3. This is the plastic moment capacity.

1.17.8.5 Hold-downs

Hold-downs or bearing replacement may be needed at vulnerable bearings such as fixed or rocker type steel bearings.

1.17.8.6 Use of State Stockpile Wire Rope (Cable) for Seismic Retrofit

The Agency is no longer stockpiling wire rope.

1.18 FRP COMPOSITES

[1.18.1 FRP Composites](#)

[1.18.1 FRP Composites](#)

(Reserved for future use)

1.19 (RESERVED)

1.20 CONCRETE ANCHORS

[1.20.1 Anchor Bolts / Rods](#)

[1.20.2 Drilled Concrete Anchors](#)

[1.20.1 Anchor Bolts / Rods](#)

1.20.1.1 Materials

Anchor bolts / rods, including those for bridges, signs, traffic signals, and illumination structures, should normally be specified according to one of the following specifications:

ASTM F1554 is the preferred specification.

- ASTM F1554, Grade 36 for low-strength
- ASTM F1554, Grade 55 for medium-strength
- ASTM F1554, Grade 105 for high-strength

Equivalent ASTM designations for anchor bolts / rods are:

- ASTM A307 - Low-strength carbon steel bolts for general use (non-headed rods conform to ASTM A36)
- ASTM A449 - Medium carbon steel bolts and rods to 3 inch diameter. Proof load requirements are similar to ASTM F3125 GR A325.

Galvanize anchor bolts or rods full length, if galvanizing is desired.

Anchorage of anchor bolts and rods may be accomplished by hooks for ASTM A307 and Grade 36 materials. For higher strength materials, a bearing plate tack welded to a nut or a plate between two nuts should be used.

If tensioning of anchor rods or bolts is desired, load indicator washers may be used up to 1-1/4 inch diameter (the largest available). Load indicator washers must be called out on the plans or in the Special Provisions, if you want them used. Recognize that concrete creep and shrinkage may significantly reduce anchor rod stress over time.

1.20.1.2 Anchor Bolt Sleeves

To allow for some flexibility in placement and small corrections in bearing locations, an anchor bolt sleeve is often used. The anchor bolt can be field bent slightly to fit the required bearing location. The bearing plate can be temporarily shimmed and then the pad constructed or the pad can be constructed with a blockout around the bolt. The sleeve is grouted at a later time. There are commercially produced anchor bolt sleeves or a fabrication detail can be added to the drawings.

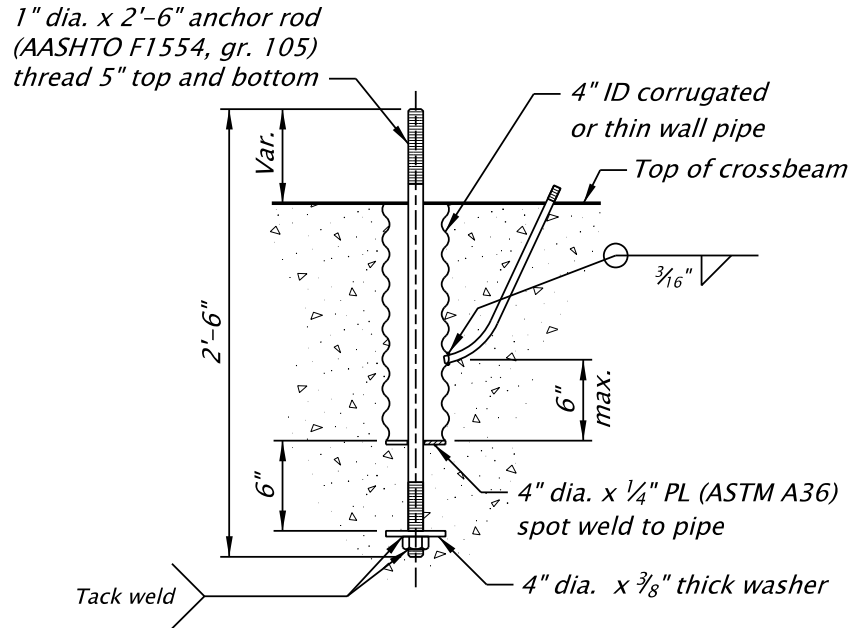

ANCHOR ROD DETAIL

Figure 1.20.1.2

1.20.2 Drilled Concrete Anchors

1.20.2.1 Materials

Anchors - Normally specify ASTM F1554, which is an anchor rod material. ASTM specifications may be substituted as follows:

<u>Anchor Rod Specifications</u>	<u>ASTM Specifications</u>
ASTM F1554 GR 36	A307
ASTM F1554 GR 105	A193 (Grade B7) or A449
M31 Rebar, Grade 60	A706 or A615

- Galvanizing is only required if portions of the anchor are exposed.
- Anchor rods do not necessarily need to be fully threaded. Specify the thread length to best fit the particular application.

Bonding material - Use a resin bonding system from the Division's QPL for anchor bolts 1 inch diameter or less. For larger anchors, use other types of anchorage such as epoxy grout or cementitious grouts with traditional development lengths.

For Grade 36 and Grade 55 anchors, use a "low strength" or "high strength" resin.

For Grade 105 anchors and reinforcement, use "high strength" resin.

1.20.2.2 Design

Design the steel portion (rod or reinforcement) of the concrete anchor according to the appropriate AASHTO design specification. Do not specify anchors larger than 1 inch in diameter using a resin bonded anchor system.

Anchors - Diameters and Stress Areas			
Diameter (in.)	Stress Area (in ²)	Bar Size	Stress Area (in ²)
0.5	0.142	4	0.20
0.625	0.226	5	0.31
0.75	0.334	6	0.44
0.875	0.462	7	0.60
1.00	0.606	8	0.79

Figure 1.20.2.2A

FHWA Technical Advisory T5140.34 regarding use of adhesive anchor under sustained tension loads was issued in January 2018. According to the Technical Advisory, FHWA recommends that post-installed adhesive anchors can be used for resisting sustained tension loads only if specific requirements are met. The recommendations were based on NCHRP Reports 639 and 757, ACI 318, and ACI 355.4. Recently, anchoring to concrete design guidance was added to Section 5 of the AASHTO LRFD design specifications, which refers to the ACI design code. The new requirements apply to all new Federal-aid projects.

Ensure that resin bonded anchors are embedded in good concrete without active cracks. Avoid using resin bonded anchors in areas with high tensile stresses perpendicular to anchor holes. Drilled holes in concrete attract or even induce cracks at the hole location. Cracks in the concrete will then tend to break down the bond between concrete and epoxy resin. Do not use resin bonded anchors to resist earthquake forces in plastic hinge zones. Use of resin bonded anchors for shear lugs and beam seat extensions is acceptable.

Design resin bonded anchors with loads, load factors, and load combinations specified in *LRFD Section 3* and with resistance factors according to *ACI 318 Chapter 17* with the following modifications:

- Uncracked concrete is assumed for design of resin bonded anchor system.
- Use a resin bonded anchor system in concrete with a compressive strength of 2,500 – 8,000 psi.
- Use resistance factors as shown in *Figure 1.20.2.2B* for applicable failure modes.

Failure Mode	Strength Reduction Factor ϕ		
	Strength Limit State		Extreme Event II Limit State
	Others	Sustained Tension	
Reinforcement in tension	0.75	0.75	1.00
Concrete breakout in tension	0.65	0.65	0.90
Adhesive bond in tension	0.65	0.33	0.90
Reinforcement in shear	0.65	0.65	1.00
Concrete breakout in shear	0.70	0.70	0.90
Concrete pryout in shear	0.70	0.70	0.90

Figure 1.20.2.2B – Resistance Factors for Design of Resin Bonded Anchors

- For concrete breakout strength in tension, $k_c = 24$.

- Use characteristic bond stresses from *Figure 1.20.2.2C* for bond strength calculation. The bond stresses shown in the figure are obtained from the Evaluation Service Report (ESR) of epoxy resin products on the QPL. The reports are approved by the International Code Council Evaluation Service, Inc. (ICC-ES). The recommended bond stresses are based on threaded rod or reinforcing bars installed in holes drilled with a hammer drill and carbide bit.

Short-Term Peak Temperature (24 hrs.)	Load Application	τ_{uncr} (psi)
Equal or Less than 130 F	Others	1200
	Sustained Tension	480
Greater than 130 F but less than 176 F	Others	800
	Sustained Tension	320

Figure 1.20.2.2C – Characteristic Bond Stress for Bond Strength in Tension Check

When any of the above design requirements cannot be met, contact resin bonded anchor technical resource for guidance.

Before 2019, ODOT used a set of equations developed in-house using historical test data for calculating anchor capacities. The equations are located in the appendix.

1.20.2.3 Drilling Holes in Concrete

If existing reinforcing steel is required by design, require bars to be located prior to drilling.

Spalling of adjacent concrete is the main concern when determining the hole location and type of drill to be used.

Resin Bonded Anchors

Center of hole is 6 inches or less from the edge of concrete

- Use either a diamond bit core drill or a carbide bit rotary hammer with four cutting edges on the diameter.

Center of hole is more than 6 inches from the edge of concrete

- Use either an air hammer, maximum 9 pound class, or a carbide bit rotary hammer with two cutting edges on the diameter.

Mechanical Anchors

- Use either a diamond bit core drill or a carbide bit rotary hammer with four cutting edges on the diameter.

Grouted Anchors

- Any type of drill will normally be acceptable. Grouted anchors should always be placed more than 6 inches from the nearest concrete edge.

1.20.2.4 Plan Details

For horizontal applications, show drilled holes angled down a minimum of 15 degrees on plan sheets.

Resin bonded anchors are considered critical, when failure of the anchors can compromise public safety. Anchors installed in the following members are considered critical.

- Items attached from tunnel ceiling or under bridge deck
- Bridge rail
- Rail divergence end block
- Shear lug
- Beam seat extension
- Sign structure support
- Shear key between existing and new concrete
- Fencing support

When these critical resin bonded anchors are used, include the following note on the plans:

Provide and install (___ “ diameter Grade (36) (55) (105) or (# ___ AASHTO M 31, Grade 60 rebar) resin bonded anchors with high strength resin from the QPL. The minimum pullout strength is lbs with a minimum embedment of _____ in. Install anchors according to the manufacturer's recommendations and the Special Provisions.

The minimum pullout strength is the smaller unfactored strength of steel reinforcement and adhesive bond in tension obtained from calculation.

List all anchors specified for a construction project in *SP 00535.45(c)*. Indicate which tests are required for the specified anchors, especially for critical anchors. For anchors that are not critical and will not see significant loads, tests during construction may be omitted.

1.20.2.5 Testing Requirements

Two types of field tests are required during construction to ensure proper installation and to achieve as-specified capacity of resin bonded anchors. Demonstration Test includes installation of anchors using the same material and methods as shown on the plan and testing the anchors to a load at minimum pull out strength. Production Test is performed during construction on actual anchors used in final position up to a load level specified in the Special Provisions.

1.20.2.6 Construction

Drill types - See *BDM 1.20.2.3* or *SP 00535* for the drill type to be used.

Holes - Holes for resin bonded anchors are normally 1/8 inch diameter larger than the nominal bolt diameter. Holes should be cleaned with compressed air, a non-metallic brush and water. Concrete dust is one of the most destructive elements to a resin bonded system and water is the best method to remove the dust. Holes for grouted anchors are normally 1/4 inch diameter larger than the anchor diameter.

Temperature - Epoxy resin is not allowed for low temperature applications. The set times become quite long at low temperatures. It will normally be better to use a deeper embedment with a non-epoxy product at low temperatures. Note that "high strength" resins will normally be epoxy.

Tightening – *SP 00535* requires tightening to only 1/4 turn past snug tight. Consider what tightening is appropriate for the application and show on the plans, if different than the specifications. Anytime load indicator washers are used, tightening must meet the washer requirements. Also check if distribution plates are needed to transfer the bearing loads (from the tensioned bolt) to the concrete.

1.21 STRUCTURAL WIRE ROPE (CABLES) AND TURNBUCKLES

[1.21.1 Structural Wire Rope \(Cables\) and Turnbuckles, General](#)

[1.21.2 General Notes for Structural Wire Rope, Turnbuckles and Connections](#)

[1.21.3 Special Provisions for Wire Rope](#)

[1.21.4 Special Provisions for Turnbuckles and Socket Connections](#)

[1.21.5 Design Properties](#)

[1.21.1 Structural Wire Rope \(Cables\) and Turnbuckles, General](#)

Structural wire rope (cable) may be used in seismic retrofit and safety cable applications. For these applications, structural wire rope must have zinc coating for corrosion protection. ASTM A603 structural wire rope with a Class C coating is the preferred wire rope specification. This wire rope has large wires and significant zinc coating. However, A603 wire rope is only available by special order at a minimum of 10,000 feet.

ODOT currently has a stockpile of 7/8 inch diameter A603 wire rope that is available for use on seismic retrofit applications (see [BDM 1.17.8.6](#)). The stockpile material was purchased as part of the Willamette River (Abernethy) Br. (Seismic Retrofit) Section (Contract No. 12349). The wire rope was received at the District 2B Lawnfield facility in Clackamas on September 19, 2000. As of October 2009, 2500 feet of the stockpile wire rope was still available.

Use A603 wire rope for all coastal seismic retrofit applications. If there is not sufficient quantity of wire rope available in the stockpile, a new order of 10,000 feet should be purchased using project funds. Such a purchase will require preapproval from FHWA since the excess wire rope will be stockpiled for use on future projects.

For non-coastal applications, A603 wire rope is still preferred. However, ASTM A1023 wire rope can be used where less corrosion protection is considered acceptable. A1023 wire rope uses smaller wires and has approximately one-third the zinc coating compared to A603. However, A1023 wire rope is readily available on the market and so does not need to be stockpiled. Optional sizes of A1023 wire rope are also readily available. Those sizes are listed in [BDM 1.21.5](#).

A603 and A1023 are the only wire rope specifications recommended for seismic retrofit applications. Other types of wire rope investigated are ASTM A586 and ASTM A741. A586 wire rope is used for high-strength structural tension members, but is not readily available on the market. A741 wire rope is used for safety barrier applications (such as I-5 median between Portland and Salem). A741 has less strength compared to A603 and A1023, is difficult to make swaged connections, and is also not readily available.

Bridge Design Manual – June 2020
Oregon Department of Transportation
Section 1 – Design Standards

7/8 inch diameter wire rope is recommended for most seismic retrofit applications. 1/2 inch diameter wire rope is recommended for safety cable applications and seismic retrofit applications where the wire rope must be wrapped around tight corners. Bending radius for A603 wire rope should be as follows:

<u>Wire Rope Diameter (in)</u>	<u>Suggested (in)</u>	<u>Minimum (in)</u>
1/2	18	11
7/8	32	18

ASTM A1023 wire rope can be bent to a slightly smaller radius:

<u>Wire Rope Diameter (in)</u>	<u>Suggested (in)</u>	<u>Minimum (in)</u>
1/2	13	9
3/4	19	13
7/8	23	15
1	26	17
1-3/8	35	24

The bending radius values above are based on a 1997 Bethlehem Wire Rope product catalog from Williamsport Wire Rope Works, Inc.

[1.21.2 General Notes for Structural Wire Rope, Turnbuckles and Connections](#)

Use the following general notes on the plans for structural wire rope in seismic retrofit applications using the 7/8 inch diameter wire rope from the ODOT stockpile:

Zinc-coated 7/8 inch diameter structural wire rope for seismic restraint devices will be provided by the Agency.

Use the following general notes on the plans for structural wire rope in seismic retrofit and/or safety cable applications using ASTM A1023 wire rope:

Provide zinc-coated X" (1/2", 3/4", 7/8", 1" or 1 3/8") structural wire rope for seismic restraint devices (and/or safety cables) according to ASTM A1023.

Use the following general notes on the plans for turnbuckles and wire rope connections in seismic retrofit and/or safety cable applications:

Provide hot-dip galvanized turnbuckles according to ASTM F1145.

Provide hot-dip galvanized socket connections. Ensure socket connections can develop the minimum breaking strength of the connecting wire rope.

1.21.3 Special Provisions for Wire Rope

Under the heading "Structural Wire Rope for Seismic Restraints & Safety Cables" use the following:

[When using 7/8 inch wire rope from the ODOT stockpile for seismic retrofit:]

Zinc-coated 7/8" diameter structural wire rope for seismic restraint devices will be provided by the Agency. Agency provided wire rope was manufactured according to ASTM A603 with Class C coating. Wire rope construction is 6 x 7 with a Wire Strand Core (WSC). Agency provided wire rope has been previously certified to meet a minimum breaking strength of 71,600 pounds. Wire rope is stored on spools with up to 2500 feet on each spool.

Agency provided wire rope is stored at the following location:

c/o District 2B Manager
Oregon Department of Transportation
9200 SE Lawnfield Rd
Clackamas, OR 97015
Phone: 971-673-6200

Notify Bridge Engineering Headquarters of the quantity of wire rope removed within 24 hours. Follow up this notification with a written memo documenting the time of removal, quantity removed (to the nearest foot), and the project for which it will be used. Send the memo to:

Bridge Operations & Standards Managing Engineer
Bridge Engineering Headquarters
4040 Fairview Industrial Drive SE, MS #4
Salem, OR 97302-1142
Phone: 503-986-3323
FAX: 503-986-3407

The quantity of wire rope included for use in this project, including both testing and installation, is (____) linear feet. This quantity of wire rope will be provided at no cost to the Contractor. Additional wire rope required by the Contractor due to fabrication errors and/or waste must be purchased from the Department at the Department's cost as established by the Engineer.

[When using ASTM A1023 wire rope for seismic retrofit:]

Provide zinc-coated X" (1/2", 3/4", 7/8", 1" or 1 3/8") diameter wire rope for seismic restraint devices according to ASTM A1023. Provide 6 x 19 wire rope construction with a steel core. Manufacture wire rope from extra improved plow steel. Ensure a minimum breaking strength of XX,XXX pounds (insert appropriate strength from design properties in *BDM 1.21.5*).

[When using 1/2 inch wire rope for safety cable:]

Provide zinc-coated 1/2" diameter structural wire rope for safety cable according to ASTM A1023. Provide 6 x 19 wire rope construction with a steel core. Manufacture wire rope from extra improved plow steel. Ensure a minimum breaking strength of 23,900 pounds.

1.21.4 Special Provisions for Turnbuckles and Socket Connections

Use the following special provisions for turnbuckles and/or socket connections in seismic retrofit and/or safety cable applications:

Provide Type 1 hot-dip galvanized turnbuckles according to ASTM F1145.

- Ensure turnbuckles develop the minimum breaking strength of the connecting wire rope.
- Provide turnbuckles with a 24 inch take-up unless shown otherwise.
- Test turnbuckles according to the requirements outlined in ASTM A1023.
- For seismic restraint devices, provide either a jam nut or lock wire at each end of each turnbuckle. For safety cables, provide lock wire at each end of each turnbuckle. Provide 14 gage or heavier lock wire that is either hot-dip galvanized or plastic coated.

Testing for Socket Connections – Select an independent laboratory to test three sets of wire rope assemblies. Provide approximately 3 foot segments of wire rope with galvanized stud attachments at each end. Provide stud attachments of similar size and material as to be used on the project. Test each wire rope assembly to failure in tension. Ensure the tested wire rope assembly develops the minimum breaking strength of the wire rope and ensure that failure does not occur in the connecting parts. Ensure all three wire rope segments meet the minimum breaking strength requirement. However, if the wire rope breaks at a load less than the minimum breaking strength of the wire rope and at a location at least 6 inches from a connection, that test will be disregarded. If any wire rope assembly fails to meet these requirements, except as noted above, revise the connection details and prepare and test three new wire rope assemblies.

1.21.5 Design Properties

Modulus of elasticity for wire rope (non-prestretched) = 10,000 ksi.

Approximate gross metallic area and minimum breaking strength for wire rope:

<u>Wire Rope Diameter (in)</u>	<u>Area (in²)</u>	<u>Strength (lb)</u>	<u>Weight (lb/ft)</u>
1/2	0.119	23,900	0.46
3/4	0.268	52,900	1.04
7/8	0.361	71,600	1.41
1	0.471	93,000	1.85
1-3/8	0.906	173,000	3.49

Area values above are approximate and are based on ASTM A603. Minimum breaking strength and weight values above are based on ASTM A1023. Note that A1023 does not provide area values. Weight values for A603 are slightly smaller.

The sizes of ASTM A1023 zinc-coated wire rope shown above are readily available from northwest suppliers.

1.22 (RESERVED)

1.23 BRIDGE END PANELS, AND SLOPE PAVING

[1.23.1 Bridge End Panels and Supports](#)

[1.23.2 Skewed Bridge End Panels](#)

[1.23.3 Slope Paving/Railroad Slope Protection](#)

[1.23.1 Bridge End Panels and Supports](#)

Provide reinforced concrete bridge end panels for bridges.

Show the general outline of end panels on the bridge plans with reference to the panel details shown on Bridge Standard Drawings or detail plans. Refer to *BDM 1.26.3* for end panel protective practices, such as reinforcement type and cover.

Bridge end panel supports:

- Detail ledges or other methods of support for all bridges (even if end panels are not called for when the bridge is built).
- For bridges with sidewalks and no end panels, provide a method of supporting approaching sidewalks at the bridge ends (present or future).

For Integral and Semi-Integral end bents where the end panel movement is used to accommodate thermal expansion, design and provide additional confinement and dowel reinforcement at bearing seat connection, as required.

The required width of the end panel depends on the following considerations:

- If the approach rail is a flex-beam rail, provide an end panel width of inside face to inside face of the flex-beam rails at the end of the bridge. If the rail posts are attached to the side of the panel, the end panel width is the distance between inside faces of the rail posts.
- Where the approach rail is concrete barrier, support the barrier by the end panel and provide an end panel width equal to the out-to-out dimension of the barriers at the end of the bridge. Add 1 foot each side to the end panel width where the barriers are precast.
- Supporting barriers on wingwalls (rail cast with wingwall) is not recommended because water leaks into the subgrade along the wall.

Use a nominal end panel length of 30 feet if any of the following conditions exist:

- On interstate highways and all other state highways with 20-year projected ADTT > 1000.
- When end bents are skewed > 30 degrees.
- When abutment depth is > 20 feet (from bottom of footing or cap to top of deck).
- When end fills have an anticipated post-construction settlement > 1 inch.

Use a nominal end panel length of 20 feet when none of the above conditions are satisfied.

When widening a bridge with existing end panels, use the same end panel length for the new portion as the existing. Connect the new end panel segment to the existing with dowels.

Note: $ADTT = ADT \times \%trucks$. The 20-year ADT volume should be in the project prospectus. The %trucks can be determined from data from the nearest Permanent Automatic Traffic Recorder (ATR) station. This information is kept by the Transportation Data Section under the Transportation Development Division and can be found at the following website:

<https://www.oregon.gov/ODOT/Data/Pages/Traffic-Counting.aspx>

From this website, go to “Permanent ATR Station Trends” and select the latest year.

If a prospectus is not available, if the 20-year ADT is not shown, or if an appropriate ATR cannot be found, contact the Project Leader or Contract Administrator.

Use an asphalt concrete wearing surface (ACWS) on the end panel when the approach is asphalt concrete. If the end panel settles, compensating overlays can be easily feathered onto the existing ACWS. Call out the concrete strength of end panels in the General Notes.

For 3R, bridge rehabilitation or repair projects where full-depth pavement repair is not included, only add end panels where on-going settlement is an issue, as indicated by maintenance records or through inspection element 999 (roadway impact) in condition state 3 or higher.

End panels on new bridges may be excluded under certain unique conditions. When considering to exclude end panels, submit a request for a design deviation according to *BDM 1.2.2*. Include a geotechnical and structural evaluation as supporting documents to the design deviation.

1.23.2 Skewed Bridge End Panels

For bridges with skew angle exceeding 25 degrees, detail the roadway end of the bridge end panel normal to the roadway centerline. Skews greater than 25 degrees require analysis to verify the bottom mat reinforcement, and may require expansion joint modification. See *BDM 1.9.1* for reinforcing detail in acute corner of end panel.

The roadway end of the bridge end panel may be stepped or skewed 25 degrees or less to reduce the size. A general rule of thumb is that if the approach slab area can be reduced by 50 SY or more, then consider methods for reducing end panel area. Provide the minimum end panel length as defined in 1.23.1 at any point of the roadway end of the bridge end panel to the bridge. These criteria apply to both new and existing bridge end panels. If stepped, provide the absolute minimum number of steps and locate the longitudinal construction joint on a lane line. See *Figure 1.23.2.1* for clarification.

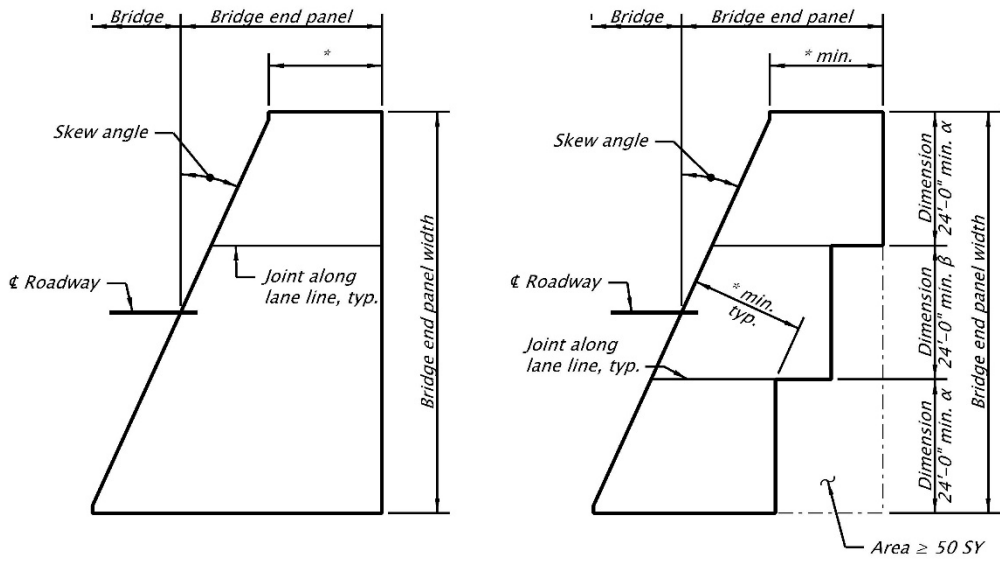

Skewed Approach – Typical

Skewed Approach – Stepped

α – Dimension may be one lane width plus the shoulder width if the shoulder $\geq 8'-0"$

β – Dimension may be two lane widths

* – Minimum End Panel Length per 1.23.1

Figure 1.23.2.1 Skewed Approach

In addition, for bridge with skew angle exceed 25 degrees; provide short flared corner bars in the acute corners of the bridge approach slabs. Typical placement is shown in the flared corner steel detail, [Figure 1.23.2.2](#).

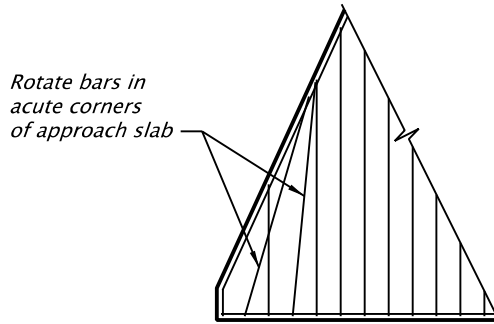

Figure 1.23.2.2 Flared Corner Reinforcing

1.23.3 [Slope Paving/Railroad Slope Protection](#)

Generally, where a roadway passes under a bridge, provide slope paving on the bridge end fill according to Bridge Standard Drawing [BR115](#). Also, consider slope paving where a bridge crosses over a sidewalk or park.

For a highway bridge crossing over a railroad, rock slope protection may be required on the end fill slope under the bridge.

1.24 BRIDGE DRAINAGE

[1.24.1 General, Bridge Drainage](#)

[1.24.2 Standard Design/Drawing/Details](#)

[1.24.3 Selection Guidance](#)

[1.24.4 Design Code Guidance](#)

[1.24.5 Design Guidance & Lessons Learned](#)

[1.24.6 Detailing](#)

[1.24.7 Construction](#)

1.24.1 General, Bridge Drainage

Some form of drainage system is normally needed on or adjacent to bridges that have curbs or concrete parapet rails. The Roadway Plans drainage details should be carefully reviewed. If drains are required, the Hydraulics Unit will do the design and determine the size and spacing. The Hydraulics Designer will need the bridge length, deck grades, cross-slope, typical section, and deck surface to determine the deck drain layout.

Normally, drainage retrofitting needs to be addressed only when the project involves a major rehabilitation of the bridge. Generally, retrofitting existing bridges from a 'direct discharge' to a piped system is not necessary. Bridge widening normally can use the same type of drainage system as the existing bridge.

1.24.2 Standard Design/Drawing/Details

DET 3120

- (1) Design Goals – Provide a “hole” thru the bridge deck to pass water.
- (2) Design Criteria – [note criteria here]
- (3) Design Assumptions – [note assumptions here]
- (4) Use Guidance / Notes to Designers – [note guidance here]

1.24.3 Selection Guidance

None.

1.24.4 Design Code Guidance

None.

1.24.5 Design Guidance & Lessons Learned

Special environmental considerations may be required on some projects (see Environmental *BDM 3.14.8*). Hydraulic requirements take precedence over water quality requirements (see Storm Water *BDM 3.14.9*).

Capture drainage upslope of the bridge in inlets before coming onto the bridge. When grades allow, carry drainage off the bridge to inlets. Drainage not carried to inlets at the ends of the bridge is removed from the bridge deck using drains.

Drains are not allowed to discharge directly into:

- designated water quality limited streams
- streams with severe non-point source pollution problems or
- streams with populations of listed, proposed or candidate threatened and endangered species of fish or other aquatic life.

In these cases provide a piping system that carries the drainage to a storm water collection swale or other dispersal system. However, only roadway surface runoff needs to be actively contained and treated because it is a pollutant source. Sidewalks are not seen as a pollutant source, and thus sidewalk runoff does not need to be transported off the structure but can sheet flow off. Include sidewalk runoff in drainage calculations. If new sidewalks are added to an existing bridge where storm water previously sheet flowed off the side, the runoff from the roadway surface will need to be contained and treated for the new condition.

When the above conditions are not present, direct discharge to the ground below may be allowed. Drainage directly discharged to the ground below is not to cause erosion or be a hazard to the public. To prevent exposure of the superstructure to the drainage, carry it by drain pipes to 3 inches below the bottom of the superstructure.

In all cases, the Bridge Designer is to coordinate with the Project Team members representing Environmental and Storm Water to determine the appropriate bridge drainage system.

1.24.6 Detailing

Provide minimum 8 inch diameter galvanized steel drain pipe.

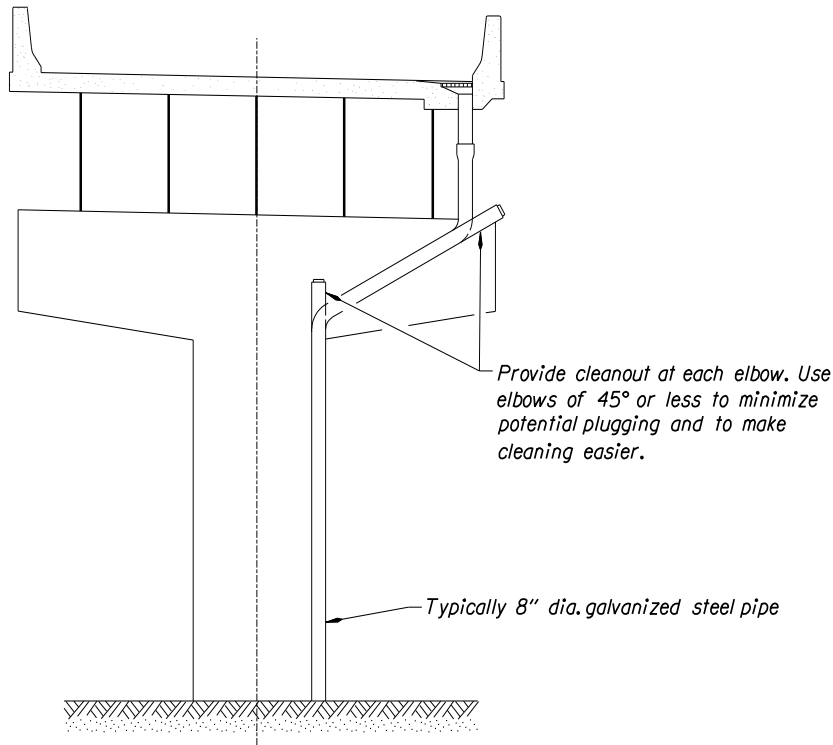

Figure 1.24.1A

Present seismic design requirements for concrete containment within columns precludes placement of drain pipes within columns.

Deck drains and drain pipes become easily clogged and are a continual maintenance problem. High pressure hoses used for cleaning cannot make 90 degree turns. For 90 degree pipe connections, use 2-45 degree connections or a 4 foot minimum radius sweeping 90 degree connection. Add clean-out ports or junction boxes at every 90 degree connection. Clean-outs should be at a 45 degree angle to the main line.

The Bridge Designer must verify that the gutter profiles do not result in "birdbaths" or unsightly dips in the rail. If there is a question, plot the gutter grade.

Place drains upslope from expansion joints to capture drainage before it reaches the joints.

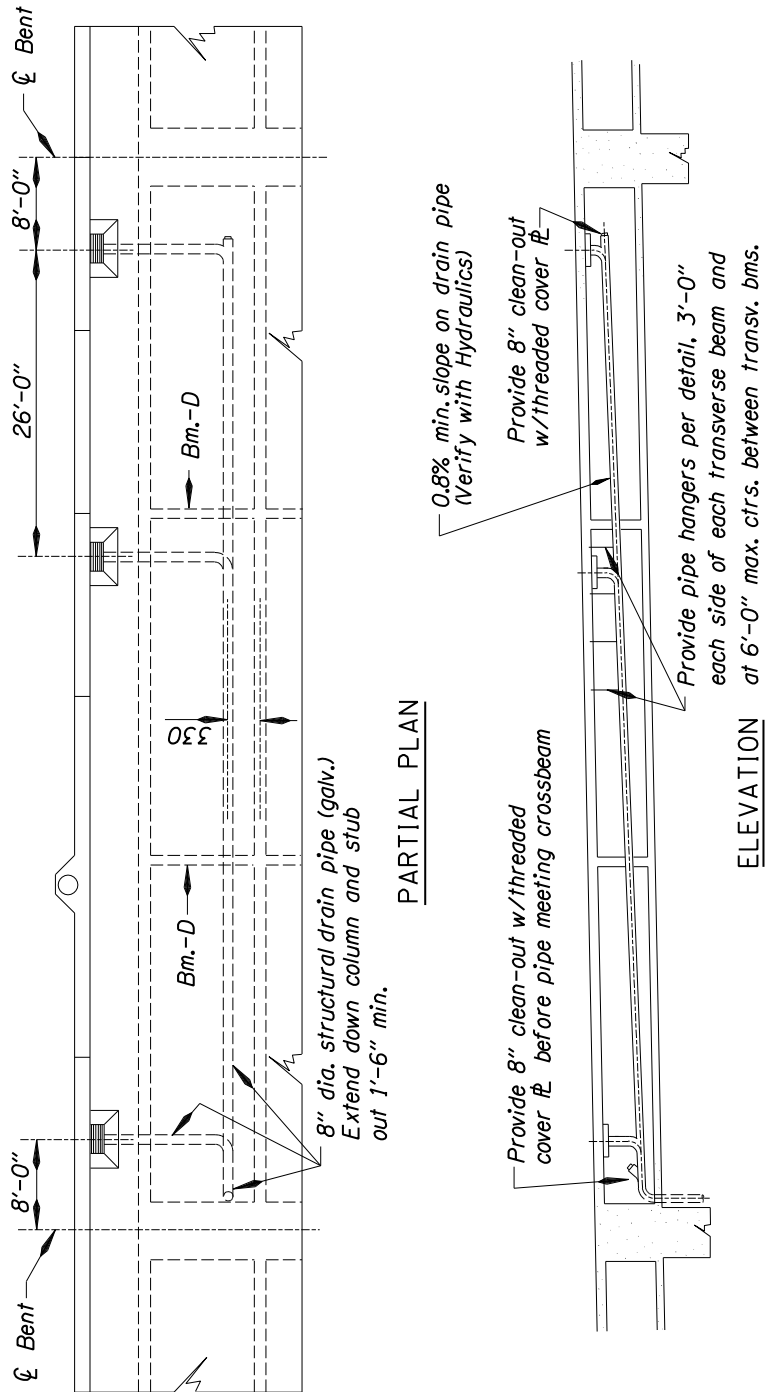

Figure 1.24.1B

Bridge Design Manual – June 2020
 Oregon Department of Transportation
 Section 1 – Design Standards

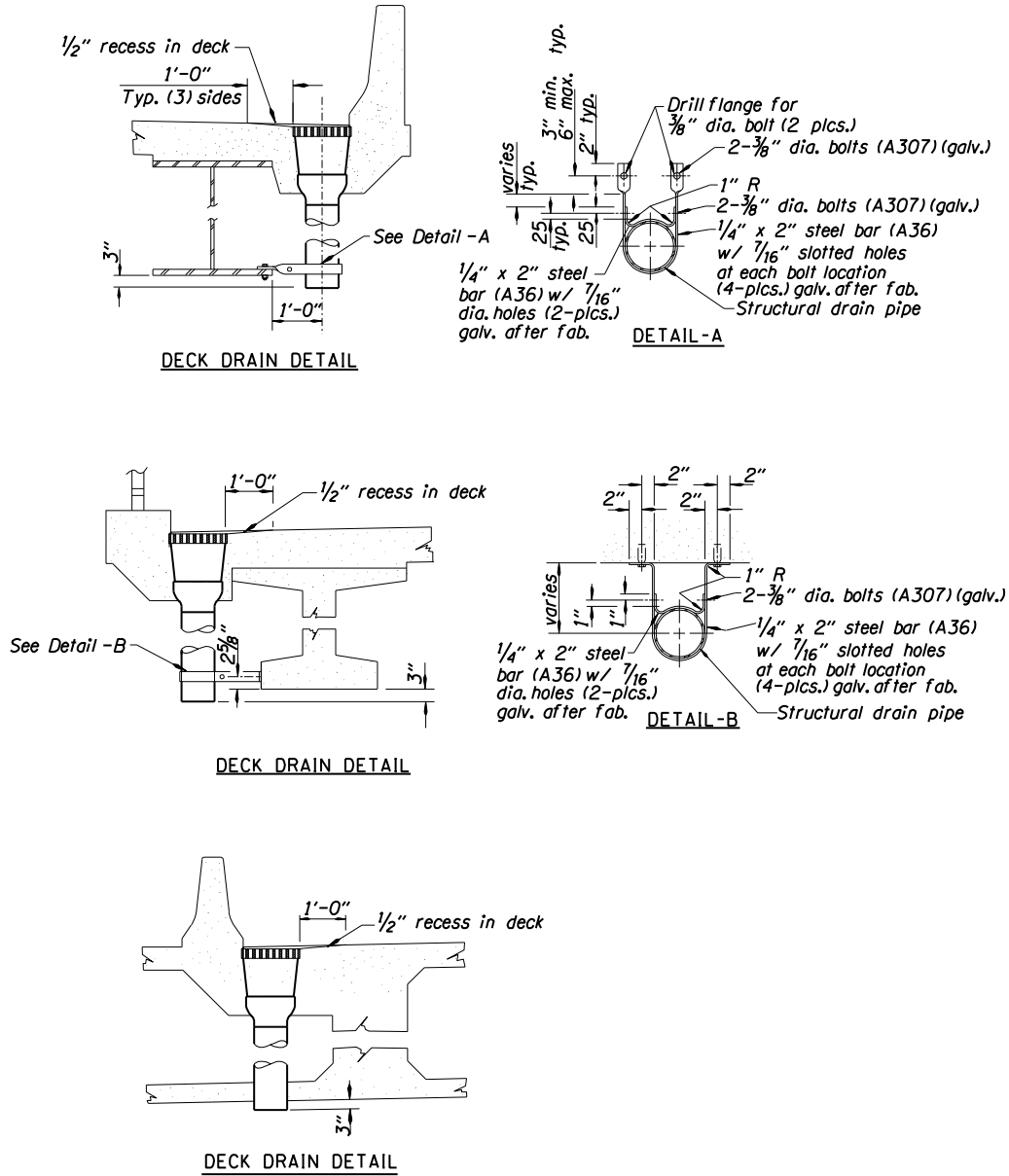

Figure 1.24.1C

1.24.7 Construction

None.

1.25 UTILITIES

1.25.1 General Requirements

1.25.2 Design and Detailing Guidelines

1.25.3 Providing for Utility Installations

1.25.4 Special Utility Considerations

1.25.5 Attachments to Existing Bridges

1.25.6 Utility Costs and Agreements

As an early design task, determine if there are:

- Requirements for carrying existing and future utilities on bridges
- Requirements for accommodating utilities in the vicinity of box culverts, sound walls, or retaining walls, especially mechanically stabilized earth (MSE) walls.

1.25.1 General Requirements

Design utility installations so that a failure will not result in damage to the bridge; be a hazard to traffic; or endanger the public.

If a proposed utility installation requires a structural evaluation, the utility plans / calculations must be stamped by an Engineer that is registered in the State of Oregon.

Include calculations for the following in the submittal:

- Vertical, lateral, and longitudinal loading, as appropriate
- Maximum and operating pressures for pressurized systems
- Waterline thrust blocks
- Loadings to be carried by the bridge and their location

If the proposed utility weighs more than 100 pounds per linear foot, the utility company will be required to provide a load rating of the bridge, with the utility loading superimposed onto the bridge, so that it can be determined whether the bridge has sufficient loading carrying capacity for the installation of the utility. If available, ODOT will provide a set of bridge plans for their use. All plans must be field verified, because not all As-Constructed bridge plans are accurate.

Use existing utility provisions located on the bridge, when possible.

Locate the utility installation to minimize the effect on the appearance of the bridge; minimize installation, inspection, and maintenance access problems; and minimize the risk of potential vehicle impacts when the bridge spans another roadway or railroad crossing. In most cases, this will mean installing the utility between girders or in the sidewalk or rail. Locate the utility as close as possible to the exterior of the bridge to allow access by snooper crane, if no other access is provided. This may not be possible if staging of the bridge is not compatible. See *BDM 2.6* for Safety and Accessibility guidance.

Provide sufficient space around utilities for maintenance activities such as cleaning and repainting steel members.

Do not extend utilities and supports below the bottom of the superstructure except when transitioning to a buried utility. Transitions are only allowed at bents or abutments.

If the utility is placed on the outside of the rail or exterior girder on stream crossings, place it on the downstream side of the bridge to minimize the chance of damage from floating debris.

Do not hang utilities against the sides of decks that have no curb. If required to put them on the side, move them out from the deck so they do not trap debris.

Avoid exterior mounted utilities in heavily sanded areas.

Some bridges have drains through the concrete railing, do not attach utilities below these drains.

Avoid attaching utilities to timber elements. Many timber elements require replacement during the bridge's life.

Avoid going through shallow end bents with no impact panel and a history of approach settlement. Excavation may increase settlement, settlement may cause the utility to shear, or the utility may get in the way of installing sheet pile or impact panels in the future.

The utility will agree that they will promptly respond to and provide a process to repair failing utilities and removing abandoned utilities.

Utilities are to be labeled at each approach or first anchorage to the bridge and every 200 feet according to American Public Works Association (APWA) standards with color code and owner, contact information, etc. Adjust spacing to include one label in each bay bounded by beams and diaphragms. See *SP 00589 – "Utility Attachments to Structures"* for additional requirements.

Install wire line type crossings in conduit.

Provide expansion fittings at each expansion joint or install on rollers as allowed by applicable safety codes. Install appropriate jumpers across expansion fittings for electrical installations.

High voltage power distributions lines greater than 22,000 volts will generally not be allowed, except in extraordinary circumstances where alternate crossings are not practical. In general, additional cost to the utility will not be considered reason enough to place power lines on bridges. Lines with voltage greater than 600 volts will be evaluated on a case-by-case basis and require written approval from the State Bridge Engineer.

Provide adequate shielding for electric power distribution lines to eliminate adverse effects of electromagnetic fields on radio signals, fuel injection systems, reinforcing and structural steel, and maintenance personnel. Provide adequate circuit protection to reduce the risk of electric shock hazards and allow for disconnection of the line upon request from ODOT. Locate disconnects within 1000 feet of the utility's first anchorage to the bridge.

1.25.2 Design and Detailing Guidelines

Utility attachments may exert large forces at the point of connection. Design individual members and the entire bridge for all loads imposed by the utility. Consider loads or movements that might be imposed on the utility by the bridge, such as from temperature or earthquake movements.

Ensure all loads are considered in the design, including dead, temperature, vibration, inertia loads, etc. Use longitudinal and transverse supports or anchorages as needed.

Include calculations for attachment connections or brackets designed by the utility company in the submittal for the designer to review. State maximum design and operating pressures for pressure systems. See *SP 00589* – “Utility Attachments to Structures” for additional requirements.

Design attachments that use a single anchor at each attachment point to remain serviceable if one of the other nearest attachments were to fail.

When drilled concrete anchors are required, follow the requirements of *BDM 1.20.2*.

Place holes in transverse members near the inside face of the outside longitudinal beams.

Maintain the alignment of utility holes as straight as possible, both vertically and horizontally, to avoid difficulties in placing utility pipes.

Construction tolerances and variables need to be considered in the design of brackets and hangers. Incorporate slotted holes, adjustable rod lengths, etc. into the attachment design.

Where utility holes are provided in the ends of the bridges for future utilities and an approach slab is required, provide each hole with concrete culvert pipe, galvanized smooth steel pipe (1/4” min. thickness), or Sch. 40 PVC pipe of the same inside diameter as the utility hole, extending from the hole to a point 5 feet minimum beyond the end of the approach panel. Extend such pipes parallel to the centerline of the bridge. Form a hole 1 inch larger in diameter than the pipe into the backwall or end beam. After the pipe is installed, fill the void around the pipe with a compressible material.

Utility holes and pipes under end panels may need to be a larger diameter to accommodate joint splices, couplers, or bells at connections.

In the absence of specific instructions from the utility company, provide hot-dip galvanized expanded coil concrete inserts with closed-back ferrule, threaded for 3/4” diameter bolts installed in the deck at 10 foot maximum centers above each line of utility holes (minimum insert length 4-5/8”, minimum safe working load in tension 5,890 pounds). If the inserts are not to be used immediately, install short galvanized bolts in the inserts to prevent rusting of the threads.

Encased conduit is to be PVC or approved equal pipe. Hot-dip galvanize external steel conduit.

Provide suitable expansion joints at bridge expansion joints.

Hot-dip galvanize steel utility supports, including fasteners and anchorages.

Steel Bridges – Suspend utility lines from the deck; do not hang from cross-frames, diaphragms, or main beams.

Prestressed Slab or Box Bridges - Provide for future utilities through the end wall closure pours with capped 8 inch diameter blockouts or by embedding a 6 inch diameter PVC pipe in the wall and extending it 8 to 10 feet beyond the bridge bent. See *Appendix Figure A1.11.1.7A*.

1.25.3 Providing for Utility Installations

When allowed by the bridge design, provide for utilities as follows:

- Agency Communication Infrastructure – on new National Highway System bridges, provide a minimum of two – 2 inch I.D. conduits for Highway communications use. Follow the detailing guidelines for utility installation in *BDM 1.25.4*.
- For bridges carrying a freeway over a river, provide for utilities that have been approved by the FHWA. Provide for future utilities on a judgment basis.

- For bridges carrying highways over freeways and other classes of highways, provide for utilities that have requested space. Provide for future utilities on a judgment basis.

Also see *BDM 1.25.5* for acceptable accommodation of utilities in bridges.

Provide for future utilities based on the proximity to heavily populated areas and the probability of future requests for utilities.

- For bridges inside city limits, provide for future needs with two 12 inch diameter holes on each side of the bridge in addition to the specific utility requirements.

Provide access for utilities as follows:

- Utilities are not accommodated on bridges unless access can be provided for inspection and maintenance by the utility, with the exception of telephone and electrical conduits continuously encased in concrete.
- Do not provide access from the freeway for bridges carrying highways over freeways. In special cases, access may be provided from freeway right-of-way, but not from the traveled roadway or shoulders.

1.25.4 Special Utility Considerations

(1) Gas Lines

Gas lines, or other lines carrying volatile materials, are to be Schedule 40 steel pipe or approved equal, and cased full length of enclosed or box type bridges. Install automatic shut-off valves at or near each end of the bridge.

Casings must be vented to outside of the bridge at each end and at high points.

Protect exposed lines from damage, both accidental and intentional. This could include barrier and fencing with locked access.

Provide transverse supports for gas lines.

Submit proposals for approval with details of the pipe, casing, vents and attachments to the bridge. Submit calculations to show that the proposed piping and casing system will be adequate for the intended purpose.

Have gas line corrosion protection systems reviewed by the Bridge Section Preservation Unit.

(2) Water Lines and Sewer Lines

Case water and sewer lines placed adjacent to bridge footings if failure of the line could cause undermining of the footing or be an environmental hazard.

Water lines are to be hot-dip galvanized steel, ductile iron pipe, or approved equal. Corrosion protection systems may include cathodic protection.

Provide transverse supports near each coupling for water lines.

In box girders, make provisions for a water line failure. Provide additional drain holes or grating at low points in the cells. Provide low pressure sensing shut-off valves fully encase the line.

Provide water line thrust blocks as required.

(3) Traffic Barrier

Limit the number and size of conduits in the bridge rail to assure ease of placement and proper consolidation of the concrete. Give special attention to details at expansion joint couplings because these tend to be much larger in diameter than the conduit.

1.25.5 Attachments to Existing Bridges

Requests for attachments to existing bridges normally come to the Region's District Manager. The District Manager submits the proposal to the Region Bridge Lead Engineer for review, comments, and recommendations. The Regions will make the final decision on any proposal. See *SP 00589* – "Utility Attachments on Structures" for additional requirements.

Review attachments to existing bridges with the same concerns and considerations of new bridges. Some additional concerns include:

- Attach conduits or brackets to concrete bridges with resin bonded concrete anchors.
- Consider Mechanical anchors on a project-by-project basis if the following considerations are satisfied:
 - Anchors are of a type that will maintain capacity under dynamic or vibratory type loads.
 - Provide at least two anchors (4:1 safety factor per anchor) per attachment for redundancy, or design attachments with a single anchor to provide a factor of safety of 6:1.
 - Avoid drilling through reinforcing steel. If critical reinforcing steel is hit, move the anchor location and patch the hole with an approved patching material. The level of concern about cutting reinforcement depends on the location of the section, amount of reinforcement at the section, and the type of reinforcement (moment, shear, temperature, etc.).
 - Protect exposed pipe and hardware against corrosion.
 - Include utility hanger details in the utility request.
 - Drill holes with low-impact rotary drill.
 - Patch any abandoned holes.

1.25.6 Utility Costs and Agreements

On new construction, the State normally provides the concrete inserts in the deck for hangers, holes through diaphragms, crossbeams and endwalls, and pipes under the end panels. This is regarded as providing minimal accommodation which essentially has zero or negligible cost ("de minimus", or below the threshold of actually costing the program) compared to not providing these items, and is acceptable per a January 2005 opinion from the Oregon Department of Justice. All other costs for materials and labor related to the utility installation are the responsibility of the utility company.

If a utility company requests the addition of conduits in a sidewalk or concrete rail, special attachment brackets, inspection walkways, etc., it is the expense of the utility company.

In such a case, an agreement is needed between the State and the utility company before the work can be included in the project. The Utility & Railroad Coordinator in the Right of Way Section writes the agreement. Notify the Utility & Railroad Coordinator as soon as possible in the project development process (preferably at the TS&L stage or before), to ensure an agreement can be reached and the work can be included in the project.

1.26 CORROSION PROTECTION

[1.26.1 Marine Environment](#)

[1.26.2 Marine Environment Protection](#)

[1.26.3 Deck and End Panel Reinforcement Protection](#)

[1.26.4 Waterproofing Membranes](#)

[1.26.5 Protection for Steel Piling](#)

The level of effort to prevent reinforcing steel corrosion depends mainly on the potential for exposure to a corrosive environment.

1.26.1 Marine Environment

For the purposes of determining when the specified corrosion protection is required a Marine Environment is defined as any of the following:

- A location in direct contact with ocean water, salt water in a bay, or salt water in a river or stream at high tide (substructure).
- A location within 1/2 mile of the ocean or salt water bay where there are no barriers such as hills and forests that prevent storm winds from carrying salt spray generated by breaking waves.
- A location crossing salt water in a river or stream where there are no barriers such as hill and forests that prevent storm winds from generating breaking waves.

1.26.2 Marine Environment Protection

Provide the following minimum protection system for structures in a Marine Environment:

- Stainless steel for all deck, girder and crossbeam reinforcing steel.
- Black steel (no epoxy coating) for prestressing strands in precast members (to allow for future cathodic protection if needed).
- Minimum 2 inch cover on all cast-in-place members.
- HPC (microsilica) for all precast and cast-in-place concrete.

Review additional protection measures including concrete sealers, cathodic protection or others with the Corrosion Specialist on a project-by-project basis.

1.26.3 Deck and End Panel Reinforcement Protection

The protection system for deck and end panel reinforcement is shown in *Table 1.26.3A* below. Required reinforcement cover for all decks is 2.5 inches for the top mat and 1.5 inches for the bottom mat.

For reinforcing steel extending out of the deck or end panel into bridge rails, curbs or sidewalks, use the same type of reinforcement as used in the deck or end panel. Use black (uncoated) steel for all other bridge rail, curb or sidewalk reinforcement.

Examples are shown on the following pages in *Figures 1.26.3A and 1.26.3B*.

Table 1.26.3A

DECK AND END PANEL REINFORCEMENT PROTECTIVE PRACTICES

	Coastal Areas (within 1 air mile of the Pacific Ocean)	Snow/Ice Areas*	Mild Areas**
Concrete Type	HPC (microsilica)	HPC (microsilica)	HPC (microsilica)
Reinforcement Type	<u>Deck</u> – Stainless steel or GFRP top and bottom mats <u>End Panel</u> – Black (uncoated) top and bottom mats	Epoxy coated or ChromX 4100 top and bottom mats in both the deck and end panel	Black (uncoated) top and bottom mats in both deck and end panel

* Snow/Ice areas are defined as all areas of central and eastern Oregon, the Columbia River Gorge, Jackson County, and any other areas above 1500 feet elevation or otherwise identified by the associated maintenance district.

** Mild areas are defined as all areas not in a coastal area or in a snow/ice area. This includes all of western Oregon below 1500 feet elevation that is not within 1 mile of the Pacific Ocean.

Non-Coastal Cast-in-place Decks - For cast-in-place concrete decks, provide 2-1/2 inches of cover over the top mat of reinforcing steel. If a **corrosion protection system** is required, **provide corrosion resistant rebar for** top and bottom longitudinal and transverse **mats** (including "truss" bars) and **for** all bars extending from the deck into the sidewalk, curb or railing. Stirrups for precast girders do not need to be **corrosion resistant**.

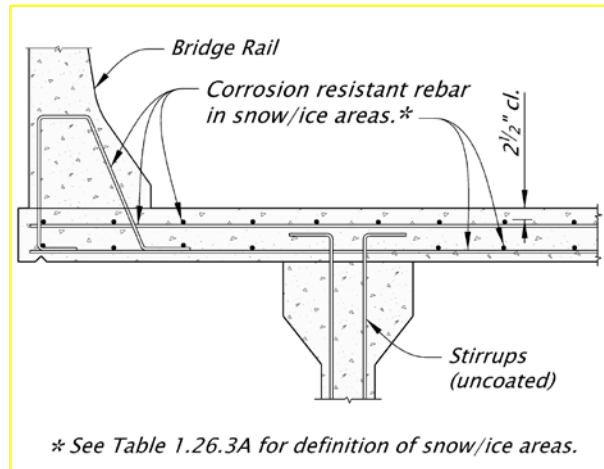

Figure 1.26.3A

Non-Coastal Precast Slabs and Boxes - Precast slabs and box beams require PPC overlay or cast-in place HPC deck. ACWS with waterproof membrane may be used on existing bridges. If **corrosion protection systems are** required, **provide corrosion resistant rebar for** the top mat bars and bars extending from the precast elements into the sidewalk, curb or railing. See the standard drawings for other corrosion resistant bars in the precast slabs and box beams.

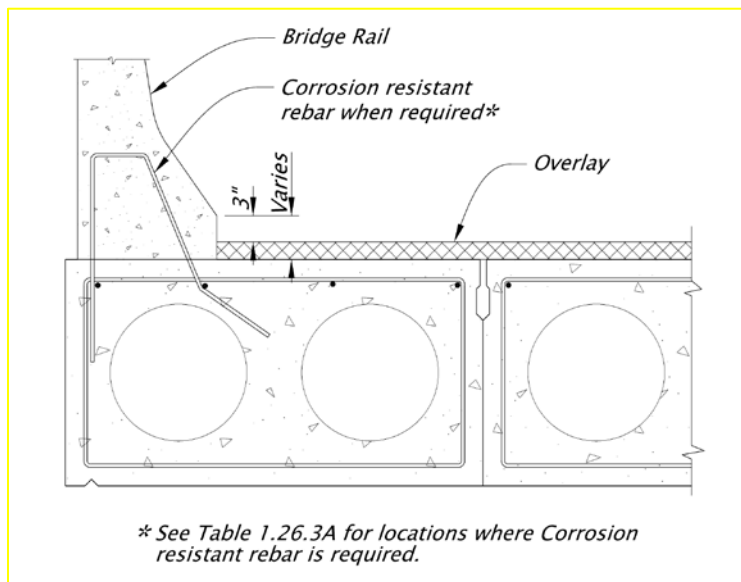

Figure 1.26.3B

When multiple metals are specified for reinforcing bars in the same elements, **provide electrical isolation between the different rebar metals to avoid galvanic corrosion.**

1.26.4 Waterproofing Membranes

Waterproofing membranes are used as part of an overall deck protection concept. They are required when paving a bridge with asphaltic concrete wearing surface (ACWS). Membranes serve the following purposes:

- Protect reinforcing steel in concrete members from corrosion by preventing moisture from roadway runoff (which potentially contains chlorides and other contaminants) from penetrating the concrete surface.
- Protect galvanized tie rods in precast prestressed concrete members placed side-by-side from roadway runoff.
- Protect timber bridge decks from moisture damage.
- Prevent roadway runoff water from passing through bridge elements to a roadway, bikeway or pedestrian way underneath the bridge.
- Prevent untreated roadway runoff water from passing through bridge elements to a waterway underneath the bridge.

Spray and Polymer waterproofing membranes are selected from the ODOT Qualified Products List.

Rolled membranes are specified by Section 00592 and accepted according to 00592.10. There is not currently a rolled membrane section in the ODOT Qualified Products List.

Consult with Structure Services to select the correct membrane type for each structure.

New State Bridges

For new bridges, ACWS is not permitted without a design deviation.

Existing State Bridges

FHWA requirements for State owned bridges states that “If deicing salts may be used in the future, some type of deck protection shall be used”.

All areas of Oregon potentially use deicing chemicals. Actual use of deicing chemicals in the project area can be verified by contacting the ODOT District Maintenance Manager.

Perform chloride testing on the existing bridge deck when warranted per *BDM 1.9.4.4* to verify existing chloride levels are acceptable.

Use a structural concrete overlay when warranted by *BDM 1.9.4.5*.

As mobilization is a significant cost to bridge paving projects, do not skip bridges during roadway paving operations. Remove all ACWS and existing membranes during paving projects, except when the existing membrane is a spray or polymer membrane that is performing well. If possible, protect these types of membranes in place during paving operations.

New or Existing Local Agency Bridges

A deck protection system is desirable and should be investigated on each project, whether NHS or Non-NHS. All federally funded projects require a deck protective system.

If a Local Agency chooses not to use a cast-in-place deck or ACWS with a waterproofing membrane for side-by-side construction, obtain written confirmation from the Local Agency. Include a copy of the Local Agency confirmation in the calculation book. Also confirm with the project environmental coordinator whether elimination of a membrane is acceptable when there is potential for roadway runoff to enter a waterway by leakage through adjacent bridge members.

1.26.5 Protection for Steel Piling

Assess all steel piling used in permanent structure applications for corrosion potential and design for the long term effects of corrosion. Reference *LRFD 10.7.5* for design requirements and guidance regarding steel pile corrosion assessment and protection. The design requirements and guidance provided in *LRFD* are further defined and supplemented in this section. Guidance on the extent of site investigations, including the soil sampling and testing required for corrosion assessment, are presented in the ODOT GDM.

The corrosion potential of buried steel piling depends primarily on the electrochemical nature of the soil surrounding the piling and the presence of oxygen and moisture. In this case, corrosion is most likely to occur at or above the water table and in disturbed stratified soils such as man-made fills, especially those containing cinders, slag or ash.

Steel pilings in waterways that extend above ground such as in estuaries, lakes or streams may also be subject to significant corrosion, especially in marine environments where the salinity of the water may be very high.

Recommended pile corrosion assessment measures, and associated design guidance, is provided below for two distinct site conditions (or physical environments): Marine and Non-Marine.

Marine Environments

Marine Environments, as defined in *BDM 1.26.2*, are typically the most highly corrosive conditions found and require the highest level of protection against steel pile deterioration. Protect all steel piling in Marine Environments with one or more of the corrosion protective systems described below. Project sites located beyond the limits described for Marine Environments may still have a significant potential for pile corrosion depending on site specific conditions. For example, if brackish water is present, or there are other indications of potential corrosive conditions consider additional soil and water testing to assess the need for additional pile corrosion protective measures.

Corrosion Protective Systems

Corrosion protection systems may be provided by the use of coatings, concrete encasement, cathodic protection, or selection of corrosion-resistant alloys. Guidance on protective coatings and cathodic protection systems are discussed below. The other protective measures, such as concrete encasement or special steel alloys, may also be considered on a case by case basis. Contact the Bridge Section Corrosion Engineer for additional guidance.

(1) Protective Coatings

When specifying protective coatings on steel pilings, two types of coating systems are available to designers, 3-coat system and a 4-coat system.

The 3-coat protective coating system is comprised of a zinc-rich primer followed by two coats of moisture-cured urethane/urethane-tar. The 4-coat protective coating system includes the same 3-coat protective coating system followed by a top coat.

Specify the 4-coat protective coating system for piles in direct contact with water. Coat piles full length at bents with pile tips within 25 feet of groundline. Specify 3-coat protective coating system for all other cases.

Coat all other piles from final cutoff elevation to 25 feet below groundline.

Use both *SP 00520* and *SP 00594* for protective coatings. *SP 00520* identifies where and what kind of coating system is to be used. *SP 00594* provides the preparation, application, materials, testing, measurement and payment for the specified coating system.

(2) Cathodic Protection

Galvanic anode cathodic protection can be applied to existing steel pilings or to new steel piling installations. For new piling installations, use cathodic protection in conjunction with protective coatings in order to minimize anode consumption.

Guidance for design and installation of anode systems for pilings in marine waters is provided by NACE Standard SP0176. Guidance for design and installation of anode systems for pilings in soil is provided by NACE Standard SP0169.

Make the electrical connection to the piling by brazing a brass stud on the downstream side of the piling. Provide the following project note:

“Remove coating from piling surface (approximately 4” x 4” area) and install ½”-13 x 2” brass stud using an approved brazing process. Provide 2 brass nuts and 2 brass washers with stud. Recoat piling surface with protective coating after installation of brazed stud.”

This method of corrosion protection requires regularly scheduled inspections of the exposed piling and periodic maintenance for the replacement of anodes.

Non-Marine Environments

Non-marine environments are all locations not designated as “Marine Environments”. In these areas, piles that are permanently buried and are always below the water table have a low potential for steel corrosion and therefore soil investigations and testing are not required. These areas generally have low corrosion potential; however there are special circumstances or site conditions that indicate the potential for severe corrosion potential, such as:

1. Landfills or fill materials composed of cinders, ash or slag
2. Sources of mine or industrial drainage (acidic groundwater)
3. Sites with stray electrical currents, such as electric (DC) transit systems, or high voltage power lines

Investigate these highly corrosive sites with a thorough soil and groundwater testing program consisting of soil resistivity, pH, sulfate and chloride concentrations. Corrosion protection systems, as described for Marine Environments, are required when any of the following conditions are found:

1. Soil resistivity is less than 2000 ohm-cm
2. Soil pH is less than 5.5
3. Sulfate concentrations are greater than 1000 ppm
4. Chloride concentrations are greater than 500 ppm

When all soil test results pass the above criteria, follow the corrosion design procedures described below for routine, non-marine environments.

For routine Non-Marine environments, the minimum amount of field investigation consists of resistivity and pH testing of the soils in the vicinity of the proposed piling. When soil resistivity is greater than 2000 ohm-cm and soil pH is greater than 5.5, no further evaluation is required and the steel piling should be designed with a minimum sacrificial steel thickness as described below. If either test result does not meet the resistivity or pH criteria then conduct additional testing, consisting of chloride content and sulfate content,

and consult the Bridge Section Corrosion Engineer to evaluate the need for either corrosion protective systems or other alternatives.

Additional guidance and background information on the corrosion of steel piling in non-marine environments can be found in [NCHRP Report 408](#) and AASHTO R-27-01 (2015). The minimum pH criteria of 4.0 recommended in these reference documents does not supersede the 5.5 value used in *LRFD*.

Recommended Sacrificial Steel Thickness

For sites where the measured resistivity and pH results indicate low corrosion potential a sacrificial steel thickness may be used to account for steel section loss over the life of the structure. Determine thickness loss over a minimum design life depending on project design criteria and use this reduced thickness in the pile design. At a minimum, specify a thickness loss of 1/16" to account for possible corrosion loss occurring in the steel piles. Corrosion rates for use in determining thickness loss are specified below (ref. WSDOT BDM, 2014).

- | | |
|--|-----------------|
| • Soil embedded zone (undisturbed soil) | 0.001 inch/year |
| • Soil embedded zone (fill or disturbed natural soils) | 0.003 inch/year |
| • Immersed zone (fresh water) | 0.002 inch/year |

Double the corrosion loss for steel H-piling since there are two surfaces on either side of the web and flanges that are exposed to corrosive conditions. For pipe piles, shells, and casings, the corrosion allowance is only needed for the exterior surface of the pile. The interior of the pile will not be exposed to sufficient oxygen to support significant corrosion.

Use this approach with caution since it can limit opportunities to extend the life of the structure in the future.

1.27 ON-BRIDGE SIGN & ILLUMINATION MOUNTS

[1.27.1 Traffic Structures Mounted on Bridges, General](#)

[1.27.2 On-Bridge Sign Mounts](#)

[1.27.3 On-Bridge Illumination Mounts](#)

[1.27.1 Traffic Structures Mounted on Bridges, General](#)

The following traffic structures may be located on bridges, although standard traffic lighting poles are the only traffic structures with standard bridge connection designs. The placement of other traffic structures on bridges should be discouraged. In special cases where other (larger) traffic structures must be located on a bridge, they should be connected directly to a bent.

- Standard lighting poles
- Camera poles
- Structure mounted signs (signing for traffic passing under bridge)
- Miscellaneous small signs (signing for traffic on bridge)

When a traffic structure is on a bridge, the Bridge designer will be responsible for the connection between the traffic structure and the bridge, including the anchor bolts, and will review or check the shop drawings associated with the bridge design responsibilities. In this case, the Traffic Structures Designer will have very limited involvement with the bridge structure. The ODOT Traffic Structures Design Manual has design loads and guidance for many common applications.

The decision on whether the traffic structure may be located on the bridge and the exact location of the traffic structure on the bridge will be made by the Bridge designer in conjunction with the project team. Structure mounted signs should preferably not exceed 7 feet in height. However, especially in urban areas the required sign legend may dictate a larger sign panel. The bridge designer should work with the project team to arrive at an acceptable solution, considering effects on aesthetics, sight distance, and related factors.

The Bridge designer will be responsible for the connection between the traffic structure and the Bridge, including the anchor bolts, and will review or check the shop drawings associated with the bridge design responsibilities.

[1.27.2 On-Bridge Sign Mounts](#)

Position all new side mounted signs on bridges such that the bottom of the sign or lighting bracket does not extend below the bottom of the bridges (bottom of girder flange). To ensure that the bottom of the sign is above the bottom of the bridge, maintain at least a nominal 2 inch dimension between the bottom of the sign and the bottom of the bridge to account for construction tolerances and bracket arm sag. Design bridge side mounted sign brackets to account for the weight of added lights, and for the wind effects on the lights to ensure bracket adequacy if lighting is attached in the future.

Do not place signs under bridge overhangs. Do not place signs directly under the drip-line of the structure. Provide a minimum 2 inches of clearance between the back side of the sign support and edge of the bridge.

[1.27.3 On-Bridge Illumination Mounts](#)

[Reserved for future use]

1.28 TRUSS AND MONOTUBE CANTILEVER SIGN BRIDGES

[1.28.1 Truss and Monotube Cantilever Sign Bridges, General](#)

[1.28.1 Truss and Monotube Cantilever Sign Bridges, General](#)

Refer to ODOT Traffic Standard Drawings internet webpage 600 series drawings for standard truss and monotube cantilever sign bridges. For new truss and monotube cantilever sign bridges design, see ODOT Traffic Structures Design Manual and LRFD Specifications for Structural Supports for Highway Signs, Luminaires, and Traffic Signals, 1st Edition for further guidance.

See ODOT Geotechnical Design Manual (GDM) Chapter 16 Foundation Design for Signs Signals, Luminaires, Sound Walls and Buildings for foundation design guidance for truss and monotube cantilever sign bridges.

1.29 BRIDGE RAISING

[1.29.1 Bridge Raising, General](#)

[1.29.2 Bridge Raising Using Falsework](#)

[1.29.3 Bridge Raising Using Chip-in Method](#)

[1.29.1 Bridge Raising, General](#)

Provide enough information in the contract document that enables the Construction Contractor's Engineer to design supporting elements for a bridge raising and stability of the structure during this operation.

Different construction procedures could be employed in raising a bridge. More common procedures are using falsework or 'chip-in' construction. A check needs to be made whether the bridge should be open to permit loads while under construction. Take a concrete sample of each column to verify the column's concrete strength.

[1.29.2 Bridge Raising Using Falsework](#)

Design assumptions and criteria include:

- Total dead load: Superstructure and substructure above the 'Chip-in' point, superimposed dead loads, utilities, signs, other dead loads that will remain on the bridge during the raising operation (field verify all dead loads at Project Initiation).
- Design live load: HS-25 when bridge is open.
- Close the bridge during the actual raising operation.
- For falsework design use 1.5 load factor for dead and live loads.
- When bridge is open to permit loads use 1.5 dead load factor and 1.35 live load factor.
- Temporarily pin concrete barriers that protect the bridge from damage from adjacent traffic. Provide at least 1 foot clearance between the barrier and the bridge or falsework elements.

[1.29.3 Bridge Raising Using Chip-in Method](#)

The 'Chip-in' method is a popular construction method for raising bridges. In this method concrete at the mid-point of each column is removed to provide enough room to place a jack and shims. The remaining concrete is removed and the reinforcing steel severed. After the bridge deck is brought to the desired elevation, the severed reinforcing steel is spliced and the void between the two portions of the column is filled with non-shrink concrete.

Design assumptions and criteria include:

- Total dead load: Superstructure and substructure above the 'Chip-in' point, superimposed dead loads, utilities, signs, other dead loads that will remain on the bridge during the raising operation (field verify all dead loads at Project Initiation).
- Design live load: HS-25 when bridge is open during 'Chip-in' operation; however, traffic should not be permitted in the lane adjacent to the columns that 'Chip-in' is in progress.
- Close the bridge during the actual raising operation.
- For dead loads and super imposed dead loads use 1.5 dead load factor.
- When bridge is open to traffic after the raising operation use 1.35 live load factor.
- Bridge cannot be open to permit loads unless adequacy and stability of bridge was checked for permit loads. In this case use 1.35 load factor for permit loads.
- Temporarily pin concrete barriers that protect the bridge from damage from adjacent traffic. Provide at least 1 foot clearance between the barrier and the bridge elements.

1.30 STRENGTHENING OF BRIDGES

[1.30.1 Strengthening of Bridges, General](#)

[1.30.2 Strengthening Methods and Details](#)

[1.30.3 Existing Rebar and Concrete Cover Investigation](#)

[1.30.4 Epoxy Injection](#)

[1.30.1 Strengthening of Bridges, General](#)

The terms “Strengthening” and “Repair” are sometimes used interchangeably to describe an action, but they are not the same. Strengthening is the addition of load capacity beyond the level provided for in the original design. Repair is the restoration of the load capacity to the level of the original design.

Bridge strengthening is required when the critical load rating factor for a bridge falls below 1.0. Design bridge strengthening to resist the live load given in *BDM 1.3.2(4)*.

When critical load rating factors are below 1.0 or when the bridge inspection report indicates quality issues, consider conducting material testing according to The Manual for Bridge Evaluation Sections 5.3 and 5.4. Take concrete compressive cores from each concrete grade, with at least 3 samples from each. Additional sampling locations or tests may be required for large bridges or to address localized problems. Repair all concrete sampling locations with hand patching Materials from Section 02015.30 of the QPL designated for vertical and overhead application.

Bridge repair projects are typically limited to isolated portions of the bridge and address specific needs such as substructure issues and collision damage. Examples of such cases are:

- Footings and/or columns
- Piling
- Girder damage from over height collision
- Bridge rail collision damage

In rare cases there may be extenuating circumstances to support a “do nothing” or reduced design criteria. For such cases, approval of a design deviation is required. FHWA review will also be required if a bridge is to remain in service with a critical rating factor less than 1.0. Factors to be considered in the design deviation approval process may include:

- Estimated cost of repair or strengthening
- Existing permit truck volume and potential for future increases
- Existing girder cracking
- Number of lanes and shoulder widths
- Alternate routes available
- Existing bridge detailing

1.30.2 Strengthening Methods and Details

The following are preferred methods for strengthening girders in flexure and shear. Alternative methods are encouraged and can be used with an approved design deviation (used to document use of innovative materials).

1.30.2.1 Section Enlargement

Adding depth and width to beams can increase flexural and shear capacity. Interface shear reinforcement details are important to ensure composite section behavior between new and old concrete. Shear dowels using resin bonded anchors can be used for achieving the composite section. Consider high strength rebar for flexural reinforcement in new concrete section, when space is limited. The high strength rebar reduces size and numbers of new rebar. For section enlargement with thin concrete cover, less than 4 in. thick, consider using nylon drywall anchors or stainless steel screw anchors to attain composite section.

1.30.2.2 Post-Tensioning

Post-tensioning is an active means to restore or increase flexure, shear, and anchorage capacity of bridge structural elements. Ensure that force due to post-tensioning is not excessive to avoid unintended cracking.

When longitudinal post-tensioning is used as part of a strengthening system, understand that long-term relaxation of the post-tensioning system may reduce the effectiveness of the strengthening. Account for any long-term relaxation unless provision for future tightening is included. If strengthened structural elements are located in corrosive environment, consider using corrosion-resistant high-strength bars, strands, and anchorage assemblies. Use of corrosion-resistant ducts filled with grout to encase PT strands is also an option.

1.30.2.3 Internal Shear Anchors

Internal shear anchors for shear strengthening can be installed either from above or below the girder. Installation from above may be easier and considered where practical. Specialty contractors are generally available for drilling 1 inch diameter holes up to 48 inches in depth. For this reason, limit internal shear anchor size to 3/4 inch. Do not use larger sizes or depths unless the availability of multiple contractors has been verified. Internal shear anchors should normally be placed at an angle 30 degrees from vertical. This angle provides 96 percent of the capacity compared to 45 degree anchors and is much easier to install.

Internal shear anchors require development length at each end of the rod. Calculate the required embedment depth to develop anchor rod ultimate strength according to ACI 318 17.4.5 with modification according to *BDM 1.20.2.2*. Provide adequate bar length greater than the calculated embedment length at both ends. The effective length of an internal anchor is the length remaining after subtracting the development length at each end of the bar.

1.30.2.4 Carbon Fiber Reinforced Polymer (CFRP) Wet-Layup System

Design CFRP strengthening according to ACI 440.2R-08 or AASHTO Guide Specifications for Design of Bonded FRP Systems for Repair and Strengthening of Concrete Bridge Elements. Do not use CFRP laminate strips unless the critical rating factor is greater than 0.80. Strengthening with CFRP laminate strips can be considered a long-term (more than 20 years) strengthening solution. Use intermittent strips with 4 inch minimum gap on girder webs for shear strengthening to allow for inspection of the bare concrete between the strips. Do not specify more than 3 plies of CFRP laminate to avoid crack-induced debonding failure mode.

Provide positive anchorage at the ends of CFRP laminate strips. Anchorage using CFRP laminate strips transverse to the loaded direction is not acceptable. Proper surface preparation is critical to ensure a successful FRP application.

1.30.2.5 Near Surface Mounted System

Near surface mounted (NSM) system includes cutting shallow grooves into existing concrete substrate and embedding reinforcement surrounded by epoxy resin inside the groove. NSM is less prone to delamination, environmental degradation and allows for effective inspection of concrete surfaces compared to the CFRP wet-layup system. Consider the following reinforcement materials for near surface mounted application:

- CFRP bar
- High strength bar
- Stainless steel bar
- Titanium alloy bar

NSM system can be used for flexure, shear, and anchorage strengthening of bridge structural elements. Consider using NSM system for the following bridge elements:

- Cap beams
- Girders
- Deck overhang
- Bridge deck
- Footing

CFRP is a conductive material, which can develop galvanic corrosion, when installed in concrete elements reinforced with steel rebar. Electrical isolation details are required. CFRP has linear properties up to rupture. To avoid a brittle failure, design ultimate strain is limited well below the rupture strain, therefore bond strength between CFRP bars, epoxy resin, and concrete is required to develop the tensile capacity. On the other hand, metal reinforcement has a yield point with large strain before fracture and can be bent for mechanical anchorage into concrete substrate. Mechanical anchorage at terminations is added for metal reinforcement by using standard 90-deg. hooks at both ends to provide anchorage. Design CFRP-NSM system according to ACI 440.2R-08.

NSM system using stainless steel and titanium alloy bars was investigated through tests for strength and long-term performance at OSU. See ODOT SPR 750, and SPR 775 research reports for test information. The research studies found that the materials are suitable for strengthening bridge structural elements. However, NSM system with titanium alloy bars is more efficient than the system with stainless steel rebar due to higher strength. ASTM B1009 describes material standards for NSM system with titanium alloy bars. See AASHTO Guide for Design and Construction of Near-Surface Mounted Titanium Alloy Bars for Strengthening Concrete Structures for design guidance and design examples with the following modifications:

- Reduce nominal cross sectional area using a factor of 0.96 due to surface deformations to enhance bond
- Use a specified yield strength of 130 ksi for design
- Avoid specifying #6 titanium alloy bars, due to the required 12" hook tails

Consider smaller diameter bars for strengthening thin structural elements, since required tail length for end hooks is shorter. For instance, use #3 bars for deck overhang strengthening, where a tail length of 5 inches is required for hook ends.

Even though titanium alloy bars have the strength advantage over CFRP, stainless steel, and other high strength bars, unit cost of titanium alloy bars is much higher than the others. Therefore titanium-NSM is more suitable for localized strengthening such as poor anchorage, specific deficient areas, etc.

Concrete substrate for NSM system needs to be in good condition without significant cracking, spalling and delamination. When concrete cover repair is required, additional steps for strengthening would negate

advantage of NSM construction. For structural elements with extensive concrete damage, section enlargement with high strength rebar would be more appropriate.

1.30.2.6 Other Strengthening Systems

External stirrups (vertical rods) have been used for temporary shear strengthening of concrete girders, but they are not considered adequate for permanent strengthening.

Do not use bonded and/or bolted steel plates attached to the sides of concrete girders for shear strengthening without prior approval from Bridge Section.

1.30.2.7 Strengthening Plan Details

EOR of a bridge design project is responsible for strengthening design except for CFRP wet-layup and CFRP-NSM systems. For the CFRP strengthening systems, provide the following information on plan sheets for contractor's CFRP strengthening designers:

- Existing reinforcing details including material properties, concrete section, and relevant reinforcing details for capacity calculation
- Locations and limits of deficiencies in structural element
- Required total capacity from existing section and strengthening system
- Conceptual strengthening details
- Required minimum material properties of CFRP
- Required locations of CFRP reinforcement termination for full development

Also include the following data of CFRP and composite materials used for the design of the CFRP strengthening system in General Notes sheet:

- Section properties
- Ultimate and design tensile strength
- Tensile modulus of elasticity
- Ultimate strain

When the CFRP strengthening system used in construction is different from design plans, document CFRP and composite material properties listed above in as-constructed drawings. The material data are necessary for future evaluation and load rating of the bridge.

1.30.3 Existing Rebar and Concrete Cover Investigation

Obtain as-constructed drawings and evaluate existing bar size, location, spacing, and cover thickness during design. Ensure that strengthening system is possible to be constructed, especially the strengthening methods that require drilling or cutting into existing concrete section. It is often difficult to avoid existing deck steel or existing flexural steel. The designer needs to give clear instructions to the contractor concerning how potential conflicts are to be either avoided or resolved. Possible solutions are:

- Locate existing bars and measure concrete cover using high precision rebar detector or Ground Penetrating Radar (GPR) before drilling holes or groove cutting
- Expose the top mat of reinforcement before drilling
- Relocate drilled hole or groove to an equivalent location, when a conflict is discovered
- Add reinforcement, when cutting existing bar cannot be avoided.

1.30.4 Epoxy Injection

Epoxy inject shear and/or shrinkage cracks with widths 0.016 inches and larger and where the bridge is:

- Located in a Snow/Ice area*, or
- Located in a Coastal Area (within 1 air mile of the Pacific Ocean), or
- The bridge shows signs of corrosion.

* Snow/Ice areas are defined as all areas of central and eastern Oregon, the Columbia River Gorge, Jackson County, and any other areas above 1500 feet elevation. These areas are intended to include all areas with the potential to receive periodic application of deicing chemicals.

Epoxy injection is not considered a strengthening method for either flexure or shear. However, it improves corrosion protection. Injection of cracks smaller than 0.016 inches is difficult and is only marginally effective. Cracks greater than 0.040 inches will require strengthening so the bridge will not be considered to be Structurally Deficient.

During installation of FRP repairs, epoxy inject shear and/or shrinkage cracks in the repair area with widths 0.016 inches and greater.

Reference concrete crack widths in specification documents and on plan sheets using one of the available widths provided on the ODOT crack comparator (gauge). The available widths (in inches) are as follows:

0.008
0.010
0.013
0.016
0.020
0.025

For concrete cracks greater than 0.025 inches, show crack size to the nearest hundredth.

1.31 (RESERVED)

1.32 PRESERVATION AND REPAIR

[1.32.1 Preservation and Repair](#)

[1.32.1 Preservation and Repair](#)

(Reserved for future use)

1.33 BRIDGE PAINT

[1.33.1 Bridge Paint](#)

[1.33.1 Bridge Paint](#)

(Reserved for future use)

1.34 (RESERVED)

1.35 COVERED BRIDGES

[1.35.1 Covered Bridges](#)

[1.35.1 Covered Bridges](#)

(Reserved for future use)

1.36 MOVEABLE BRIDGES

[1.36.1 Moveable Bridges](#)

[1.36.1 Moveable Bridges](#)

(Reserved for future use)

1.37 (RESERVED)

1.38 BRIDGE TEMPORARY WORKS

[1.38.1 Introduction](#)

[1.38.2 Temporary Detour Bridges](#)

[1.38.3 Agency Provided Temporary Detour Bridge](#)

[1.38.4 Falsework](#)

[1.38.5 Shoring](#)

[1.38.6 Cofferdams](#)

[1.38.1 Introduction](#)

Temporary Works are considered any temporary construction used to construct highway related structures but are not incorporated into the final structure. Temporary works required for construction of permanent structures include: temporary detour bridge, work bridge, falsework, formwork, shoring, cofferdams and temporary retaining structures.

Design Temporary Works, except seismic loading, according to the AASHTO *Guide Design Specifications for Bridge Temporary Works, 2nd Edition, 2017*, unless specified otherwise herein.

Construct Temporary Works according to *AASHTO Construction Handbook for Bridge Temporary Works, 2nd Edition, 2017*, unless included in the Oregon Standard Specifications for Construction and Special Provisions. A list of common Special Provisions and Standard Specifications are provided below for reference.

Special Provisions

<u>Title</u>	<u>Section Number</u>
Temporary Detours	00230
Temporary Detour Bridges (Contractor Provided)	00250
Agency Provided Temporary Bridges	00251
Temporary Work Bridges	00252
Temporary Work Platform	00253
Temporary Work Access	00254
Temporary Retaining Walls	00256

Standard Specifications

<u>Title</u>	<u>Section Number</u>
Structure Excavation and Backfill (shoring and cofferdams)	00510
Structural Concrete (Falsework)	00540
Trench Protection	00405.41(f)
Temporary Trench Plating	00405.46(c)
Jacking Pits	00406.41(b)

General Requirements

Roadway and Railroad Crossings

For roadway and railroad crossings, provide the vertical and horizontal clearances as shown on the plans and the following:

Bents Adjacent to Highways

Bents adjacent to highway traffic openings shall have:

- Temporarily pinned, pin and loop concrete barriers to protect the structure from damage by the adjacent traffic. Provide at least 1 foot clearance between the barrier and the bent.
- Posts designed for 150 percent of the calculated vertical loading.
- Provide mechanical connections for posts to the supporting footing with capacity to resist a minimum lateral force of 2,000 pounds applied in any direction at the base of the post.
- Provide mechanical connections between top of posts and the cap or stringer capable of resisting a minimum lateral force of 2,000 pounds from any direction.
- Tie down all beams or stringers spanning traffic so that each will resist a 500 pound force from any direction.
- 5/8 inch diameter minimum bolts at timber bracing connections.

Bents Adjacent to Railroads

Bents adjacent to railroad traffic openings shall, in addition to the requirements of (d-1) above, provide the following:

- Collision posts as shown.
- Bents within 20 feet of the centerline of track sheathed solid between 3 feet and 16 feet above top of rail with 5/8 inch thick minimum plywood and properly blocked at the edges.
- Adequately size bracing on bents within 20 feet of the centerline of the track to resist the required horizontal design loading or minimum a 5,000 pounds horizontal loading.

Width

Design temporary bridges to match the temporary roadway width and vertical and horizontal alignment as shown.

1.38.2 Temporary Detour Bridges

Temporary detour bridges are those bridges that have a maximum service life of five years to carry traffic while an existing structure is replaced.

Temporary detour bridges have the same requirements as that of a permanent structure, except as specified in this section. For seismic design requirements, refer to *BDM 1.17.2.1*. Detour bridges can be designed using latest edition Standard Specification for Highway Bridges or latest edition AASHTO LRFD Bridge Design Specifications. If the Standard Specifications for Highway Bridges are used, bridge rail live loads must meet LRFD criteria.

Hydraulics of Temporary Structures

These hydraulic requirements apply whether the Contractor uses a temporary detour structure designed by ODOT, or provides an alternate structure of his own design.

The hydraulics report will have recommendations for the detour bridge. The data will include seasonal limitations, flow area of the structure, and minimum elevation of the detour roadway. A brief statement about the proposed location of the detour will need to be prepared. Other information about the detour may include a discussion of maintenance needs such as monitoring for debris or scour. The detour structure will need to conform to the Temporary Water Management Plan regarding fish passage.

A dry season detour is to be in use only during the dry season. The hydraulics report should define the start and end of the dry season. The design and check floods are based on the maximum predicted discharges for the months the detour will be in place. It is recommended that the 2-year flood be used as the minimum design flood event.

An all-year detour may be used throughout the year. The all-year detour must pass the 5-year flood event at a minimum. The 10-year and 25-year check flows should be used to determine the risk of damage if they should occur during the time the detour is in place.

The minimum road elevations for dry season and all-year detours are the elevations at which the roadway will not overtop during the dry season or 5-year flows, respectively. [Section 3.9](#) of the ODOT Hydraulics Manual furnishes more detailed guidance on requirements for either duration detour.

Other issues, such as maintenance needs, fish passage, navigational clearance, or other site-specific needs must also be addressed.

The crossing of FEMA floodways with temporary structures requires special consideration. These temporary structures must meet additional hydraulic requirements if they are in place across the floodway between November 1 and May 31. It is recommended that ODOT Regional Technical Center staff should be contacted for assistance as soon as possible during the design process if the structure is to cross a floodway during these months.

[Section 3.8](#) of the ODOT Hydraulics Manual furnishes more detailed guidance on FEMA policy requirements.

Structural Requirements

Design all structures on public roads, temporary or permanent, to carry all anticipated loads, and forces. Temporary structures must also resist lateral loads caused by hydraulics, debris, ice, wind and other applied forces when they exist. Design temporary detour bridges over waterways assuming scour depths and design flood in accordance with the Oregon Department of Transportation Hydraulic Manual.

Mechanically connect members of the temporary detour bridge together. Design mechanical connections with a minimum capacity to resist a load in any direction, including uplift on the stringer, of not less than 500 pounds. Install all associated connections before traffic is allowed to pass beneath the span. All members at a connection need to resist the developed connection force. Design the substructure to resist all applied combined axial and lateral loads and the minimum connection design force.

Contractor designed temporary detour bridge will follow all required design steps as the design of permanent bridges. Provide necessary data to the contractor in the Special Provisions (*SP 00250*) to accelerate design such as:

- Geotechnical report
- Hydraulic report
- Environmental study and limitations
- In water work window

Furnish information on the plans not limited to following:

- Minimum structure width and number of traffic lanes
- Permit load (for permit load route)
- Minimum vertical and horizontal clearances when over crossing existing highway
- All project specific requirements (utilities, sidewalk....)

1.38.3 Agency Provided Temporary Detour Bridge

Oregon Department of Transportation has one lane and two lanes temporary detour bridges ready to erect at different locations. Provide a drawing showing the bridge footprint and foundation drawings. Contact Jeff Swanstrom at (503) 986-3337 for availability, scheduling and technical information of these bridges. Use Special Provision (*SP 00251*) for using these temporary detour bridges.

1.38.4 Falsework

General

Provide minimum jacking force capacity for lifting an existing superstructure for bearing replacement or bridge raising of 1.50 times superstructure loads (including any supported live loads) at jacking time. The vertical load used for the design of falsework posts and foundation shall be at least 150 percent of the distributed load to that post. When the post is supported on an existing structure footing limit the stress on the concrete footing from all combined loads to 80 percent of permissible concrete stress. Additionally limit the foundation loads to the allowable foundation bearing capacity.

Seismic design load is not required for temporary falsework.

For falsework spans over roadways and railroads, mechanically connect all falsework stringers to the falsework cap or framing. The mechanical connections shall be capable of resisting a load in any direction, including uplift on the stringer, of not less than 500 pounds. Install all associated connections before traffic is allowed to pass beneath the span.

Provide, as a minimum, the following design calculations and detailing of falsework drawings, for a falsework supported by existing columns of a structure for widening projects or maintenance work:

- Complete connection details.
- Location of resin bonded anchors with a note to locate the existing reinforcing prior to drilling holes.
- When resin bonded anchor rods or thru holes for bolted connections were used to support endplates or bracket connections; have the contractor field verify the location of holes prior to connection fabrication.
- Connection designed for 150 percent of the applied loads.
- Connection designed for wind load.
- Stress on existing column and supporting foundation does not exceed 80 percent allowable of each member.
- Limit the foundation loads to the allowable foundation bearing capacity.

Bridge Deck Falsework

The deck form for interior girders is usually set on the joists hung on from top flanges or supported by post from bottom flanges. It is not recommended by Oregon Department of Transportation to use embedded hangers welded to top flange or shear studs projecting from top flanges.

The Construction Handbook for Bridge Temporary Works has two examples for cantilever deck forming for steel girders. The contractor may provide double overhang brackets to minimize lock in stresses in exterior girders. *Figure 1.38.4* is provided to illustrate typical deck forming details using opposed overhang brackets attached to a steel girder.

Steel girders: Do not drill or punch holes thru interior girders web for temporary work. Include a note in the contract drawing and Special Provision that no holes in the interior girder webs are permitted.

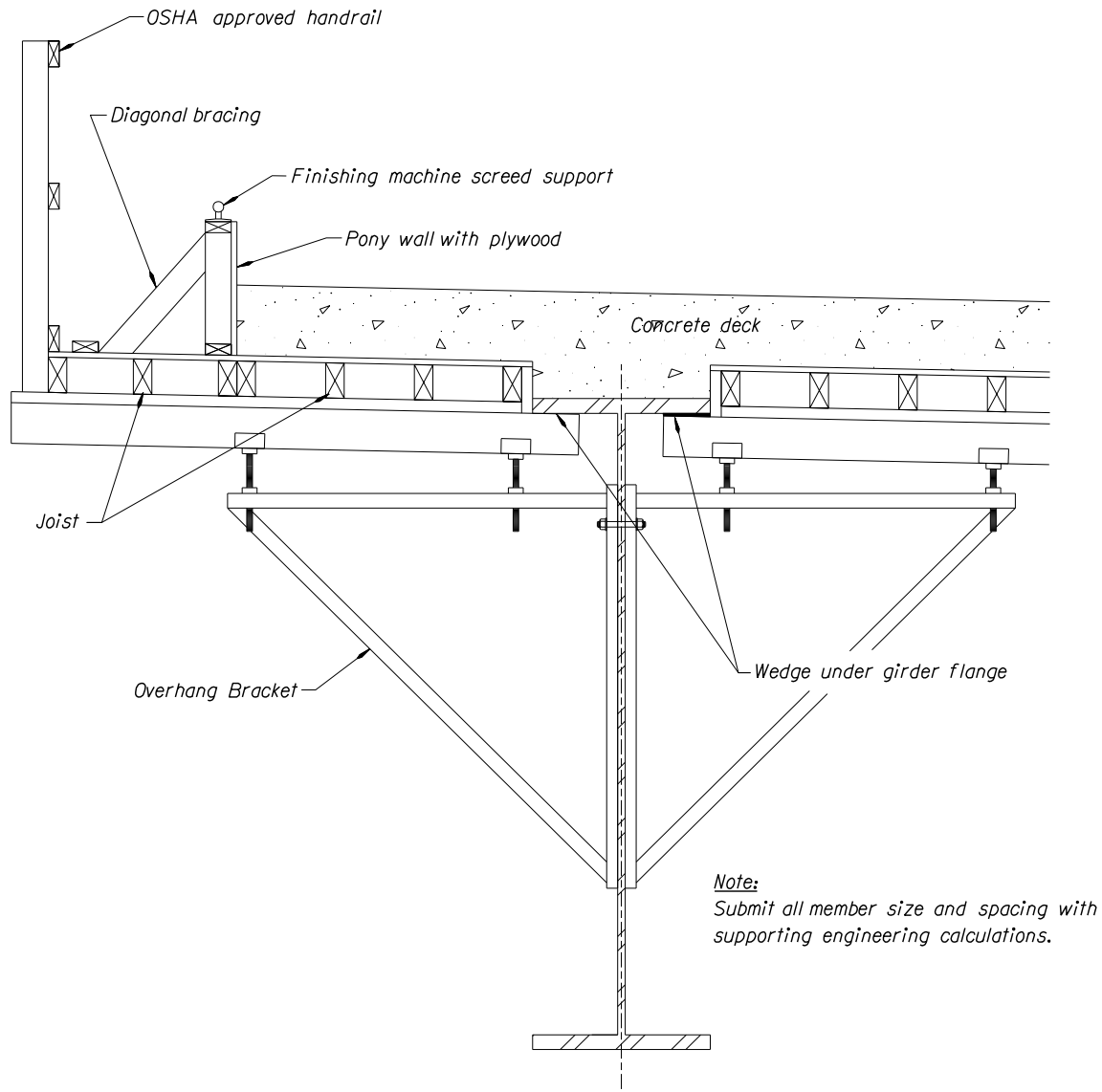

Figure 1.38.4

Piling

Design piling in accordance with AASHTO Standard Design Specifications for Highway Bridges.

When using piling to support the falsework, the falsework plans shall specify the minimum required bearing capacity and the required depth of penetration for the piling. The field method for determining the required pile bearing capacity shall be provided. Also, the falsework drawings shall show the maximum horizontal distance that the top of a falsework pile may be pulled in order to position it under its cap. The falsework plans shall show the maximum allowable deviation of the top of the pile, in its final position, from a vertical line through the point of fixity of the pile. The calculations shall account for pile stresses due to combined axial and flexural stress and secondary stresses. The design calculation shall show the stresses and deflections in load supporting members.

Spread Footings

Design spread footings in accordance with AASHTO Standard Design Specifications for Highway Bridges.

When spread footings are used to support falsework, the falsework plans shall specify the minimum required bearing capacity, depth of embedment for the footings, and maximum allowable settlement. Spread footings shall be designed to adequately resist all imposed vertical loads and overturning moments. The calculations provided for the spread footings shall include the soil parameters and groundwater conditions used in design. Design calculations for allowable bearing capacity and settlement shall be provided. The estimated footing settlement under the imposed design loads shall be shown on the plans. Provisions for addressing the effects of footing and falsework settlement shall be provided.

Bracing

Bracing shall not be attached to concrete traffic barrier, guardrail posts, or guardrail.

All falsework bracing systems shall be designed to resist the horizontal design loads in all directions with the falsework in either the loaded or unloaded condition. All bracing, connection details, specific locations of connections, and hardware used shall be shown in the falsework plans. Falsework diagonal bracing shall be thoroughly analyzed with particular attention given to the connections. The allowable stresses in the diagonal braces may be controlled by the joint strength or the compression stability of the diagonal.

To prevent falsework beam or stringer compression flange buckling, cross-bracing members and connections shall be designed to carry tension as well as compression. All components, connection details and specific locations shall be shown in the falsework plans. Bracing, blocking, struts, and ties required for positive lateral restraint of beam flanges shall be installed at right angles to the beam in plan view. If possible, bracing in adjacent bays shall be set in the same transverse plane. However, if because of skew or other considerations, it is necessary to offset the bracing in adjacent bays, the offset distance shall not exceed twice the depth of the beam.

Bracing shall be provided to withstand all imposed loads during erection of the falsework and all phases of construction for falsework adjacent to any roadway, sidewalk, or railroad track which is open to the public. All details of the falsework system which contribute to horizontal stability and resistance to impact, including the bolts in bracing, shall be installed at the time each element of the falsework is erected and shall remain in place until the falsework is removed. The falsework plans shall show provisions for any supplemental bracing or methods to be used to conform to this requirement during each phase of erection and removal. Wind loads shall be included in the design of such bracing or methods.

Deck Overhang Bracket

There are a few design examples in the Construction Handbook for Bridge Temporary Works.

1.38.5 Shoring

Refer to the ODOT Geotechnical Design Manual Section 15.3.26 for the design of temporary shoring, and defined shoring systems. Shoring is exclusive of cofferdams. See Special Provision 00510.04 for plan requirements. Modify the special provision to include acceptable types of shoring. Consult with the geotechnical engineer to determine safe slopes, minimum shoring lengths, and if there are unusual soil, clearance, or site conditions that may make shoring construction difficult.

1.38.6 Cofferdams

1.38.6.1 Earth Pressures

If cofferdams are required and passive earth pressures are assumed in the design, show a detail similar to *Figure 1.38.6.1A* on the plans. Material outside cofferdams should also be undisturbed and backfilled with riprap if disturbed.

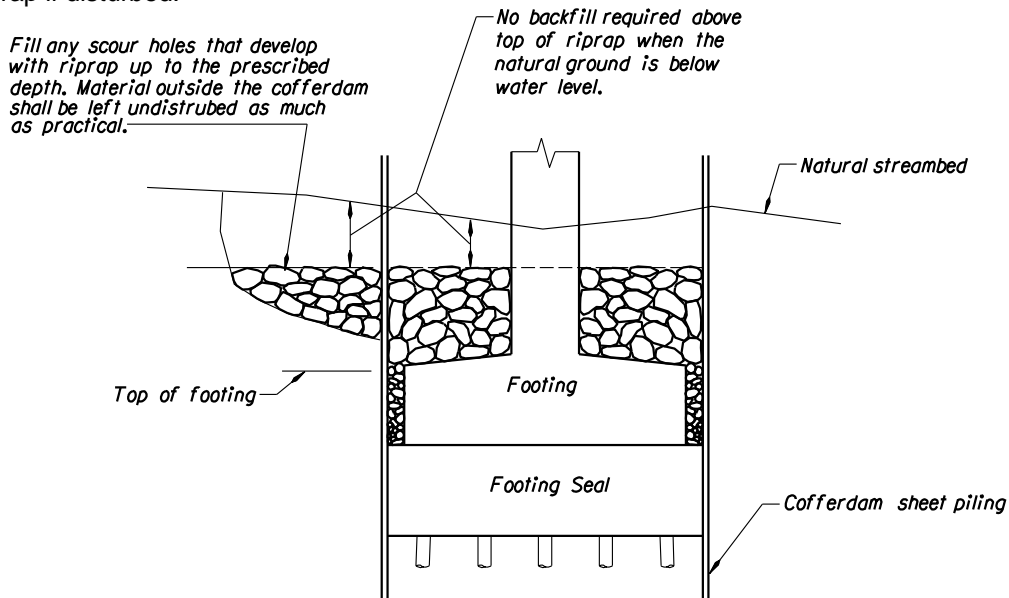

Figure 1.38.6.1A

1.38.6.2 Cofferdam Seals

(1) Seals, General

Seals should be used only when the sheet piling cannot be driven to sufficient depth to cut off the water pressure.

The sheet piling must penetrate and form a seal in the soil so that there is no water flow under the sheet piling. In practice there will be some water entering the cofferdam. Energy is dissipated as the water flows down around the bottom of the sheet piles. A flow net must be developed to determine the actual hydrostatic forces. The equipotential flow lines will show a reduction in the hydrostatic uplift forces. The hydrostatic uplift forces will be resisted by the friction between the soil and the sheet piles and the buoyant weight of the soil plug. Additionally, horizontal hydrostatic forces are present and must be designed for. These are special conditions and require detailed Hydraulic and Foundation studies.

(2) Cofferdams Without Seals

There may be some locations and soil types where a seal may not be required for footing and column construction. The normal sequence of construction for a cofferdam without a seal includes:

1. Water level is the same inside and outside the cofferdam
 - Cofferdam is constructed - normally driven interlocking steel sheet pile.
 - Vent holes are cut in the sheet piling - vent holes are placed at the maximum design water level elevation and allows water to enter the cofferdam. A vent hole must be cut at the design elevation to prevent cofferdam failure.
 - Material is excavated inside the cofferdam to the bottom of the footing elevation. Excavation may also be done after dewatering, when there is no seal required, if the internal bracing is in place.
 - Internal bracing is placed - usually horizontal bracing consists of wales, frames, and/or struts to resist the horizontal hydrostatic forces.
 - Footing piles are driven - when required. This may also be done after dewatering and after excavation.
2. Water is removed from the cofferdam
 - Continuous pumping system is installed - cofferdams are never completely watertight and a sump system is normally installed to keep the cofferdam relatively dry.
 - Piles, if used, are cut off to the specified elevation.
 - Footing and column are constructed in the dry.
3. Cofferdam is flooded
 - Internal bracing is removed.
 - If agreed to by the environmental section, riprap is placed before or after the sheet piling is removed. It may be desirable to place riprap inside the cofferdam. Check with the Geotechnical designer.
 - Sheet piling are extracted.

(3) Cofferdam with a Seal

A seal is usually an unreinforced mass of concrete that seals the bottom of a cofferdam and allows construction of the footing and column inside of a dewatered or dry cofferdam. (See *Figure 1.38.6.2A*) The normal sequence of construction of a cofferdam with a seal includes:

1. Water level is the same inside and outside the cofferdam
 - Cofferdam is constructed - normally driven interlocking steel sheet pile.
 - Vent holes are cut in the sheet piling - vent holes are placed at the maximum design water level elevation and allows water to enter the cofferdam. A vent hole must be cut at the design elevation to prevent cofferdam failure. The contractor may propose to use a lower vent elevation and thinner seal, if the anticipated water elevation is lower at the time of construction.

Bridge Design Manual – June 2020
Oregon Department of Transportation
Section 1 – Design Standards

- Material is excavated inside the cofferdam to the bottom of the seal elevation.
 - Internal bracing is placed - usually horizontal bracing consists of wales, frames, and/or struts to resist the horizontal hydrostatic forces.
 - Footing piles are driven - when required.
 - Seal concrete is placed
 - With a tremie: A tremie is a long pipe that extends to the bottom of the seal and prevents the concrete from segregating as it passes through the water, as well as permitting a head to be maintained on the concrete during placement. The bottom of the tremie is kept submerged in the mass of concrete to minimize water intrusion into the mix.
 - With a concrete pump: Similar principle to the tremie.
2. Water is removed from the cofferdam
- Cofferdam is dewatered, only after the concrete has gained sufficient strength to resist hydrostatic loads.
 - Continuous pumping system is installed - cofferdams are never completely watertight and a sump system is normally installed to keep the cofferdam relatively dry.
 - Piles, if used, are cut off to the specified elevation.
 - Seal is prepared for footing construction - leveled and cleaned as needed for constructing footing forms.
 - Footing and column are constructed in the dry.
3. Cofferdam is flooded
- Internal bracing is removed.
 - Rip-rap is placed before or after the sheet piling are removed. It may be desirable to place rip-rap inside the cofferdam. Check with the Geotechnical Designer.
 - Sheet piling are extracted.

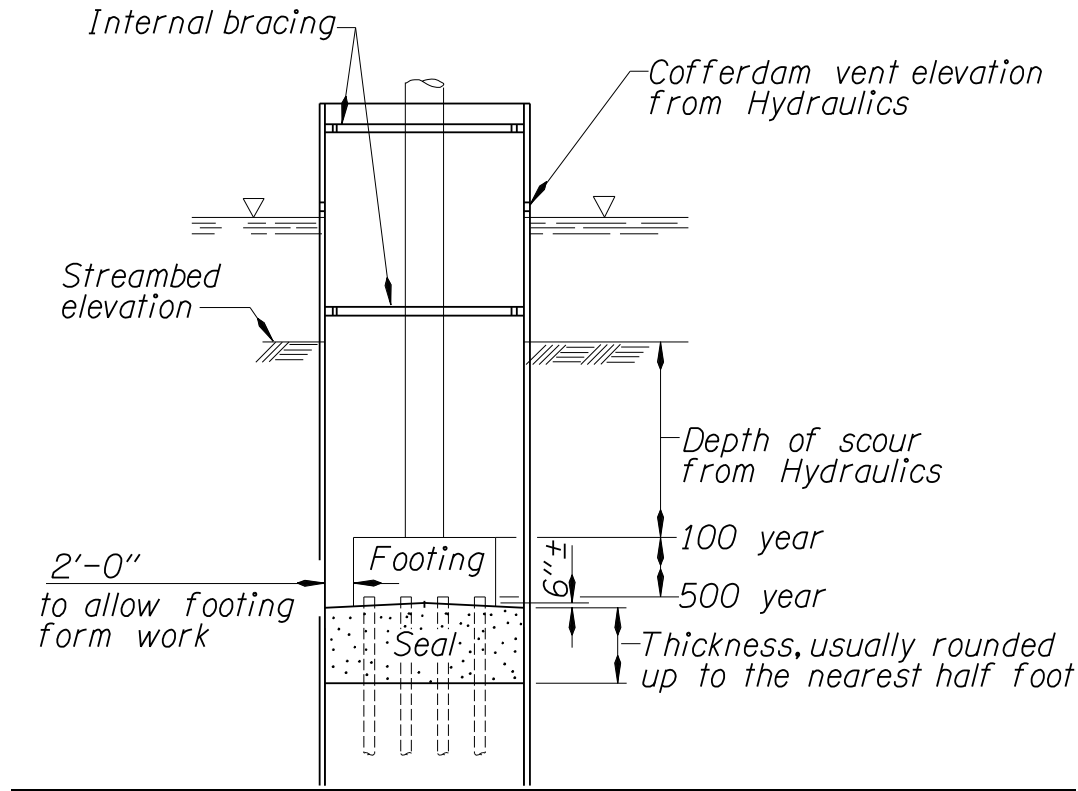

SEAL THICKNESS DETAIL

Figure 1.38.6.2A

(4) Seal Design Considerations

The seal forms a plug at the bottom of the cofferdam, using a combination of seal mass and/or friction between the seal concrete and piling to resist the hydrostatic forces.

Scour protection for the footing influences the location (depth) of the footing and must be incorporated into the design. The Hydraulics Unit will provide this information.

The top of the footing should be below the 100 year scour depth and the bottom of footing below the 500-year scour depth. The Hydraulics Unit will provide these elevations.

Normally the friction or bond between the seal concrete and steel piling is assumed to be 10 psi for the surface area of the embedded pile. Check with the Geotechnical Designer for bond values of other pile types.

An uplift capacity of driven piling should also be obtained from the Geotechnical Designer to include in the overall stability or factor of safety of the system.

The minimum factor of safety of the system should be 1. Note that the actual factor of safety is greater because the bond between the seal and sheet piling has been neglected.

A general rule of thumb, or good starting point, for seal thickness is 0.40 times (head of water plus an estimated seal thickness) for spread footings and 0.25 times (head of water plus an estimated seal thickness) for pile supported footings.

Use a minimum depth of seal of 4 feet, where piles are calculated to resist uplift in order to reduce seal depth.

Design pile footings that includes a seal for bending and shear ignoring any beneficial effects of the seal. This is due to the uncertain quality of the seal concrete and because the seal may be reduced or eliminated during construction.

There are two ways of looking at the cofferdam system when determining the seal thickness. Each should result in the same seal thickness:

Method 1: Assume there is some leakage around the seal and the actual water level inside the cofferdam is at the top of the seal. Then the hydrostatic uplift force is based on the depth of water to the top of the seal, but because it is submerged the weight of the seal must be determined using the buoyant weight.

Method 2: Assume the seal prevents any leakage and the hydrostatic uplift depth is to the bottom of the seal. Then the full weight of the seal is used to resist the uplift forces.

Spread Footing Example (using method 1):

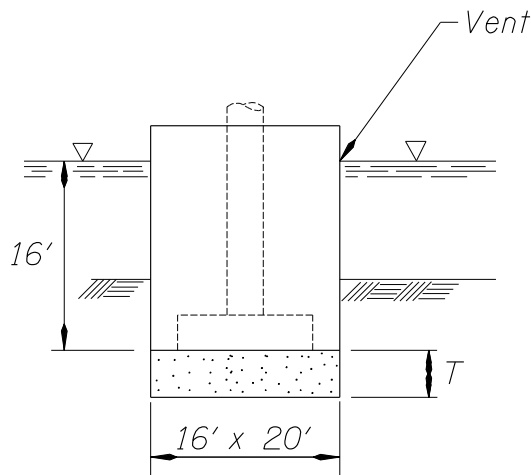

Figure 1.38.6.2B

Determine the seal thickness for a 16' x 20' cofferdam. Water depth is 16 feet from the vent to the top of the seal.

$$\text{Estimated } T = 0.4(16' + 10' \text{ est. thickness}) = 10.4'$$

Summing vertical forces:

$$\begin{aligned} \text{Uplift force} &= \text{weight of water displaced} \\ &= (\text{Area})(\text{Depth of water})(\text{Unit force of water}) \\ &= (16')(20')(16' \text{ water depth})(0.0624 \text{ k/ft}^3) \end{aligned}$$

$$\begin{aligned} \text{Force of seal} &= \text{buoyant force of the seal} \\ &= (16')(20')(T' \text{ seal thickness})(0.15 - 0.0624 \text{ k/ft}^3) \end{aligned}$$

$$\text{Uplift force} = \text{Force of seal}$$

Solving for T:

$$T = 11.4' - \text{use } 11.5' \text{ seal thickness}$$

Note: F.S = 1.0 for T = 11.4'

Pile-supported Example (using method 1):

Determine the seal thickness for a 16' x 20' cofferdam, with 12 – 12" diameter steel piles. Uplift capacity is 10 kips per pile. Water depth is 16 feet from the vent to the top of the seal.

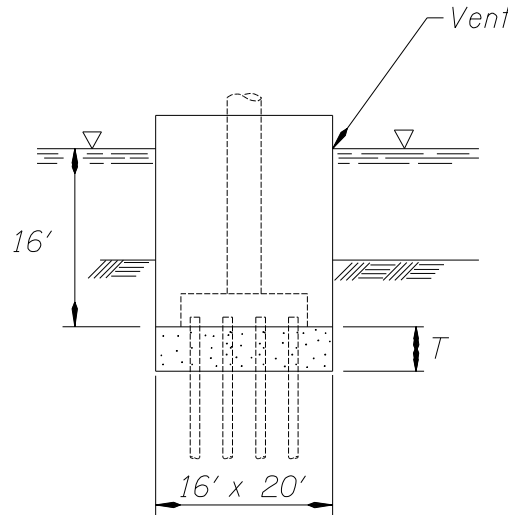

Figure 1.38.6.2C

$$\text{Estimated } T = (0.25)(16' + 10' \text{ est. thickness}) = 6.5'$$

Summing vertical forces:

$$\begin{aligned} \text{Uplift force} &= \text{weight of the water displaced} \\ &= (16')(20')(16' \text{ water depth})(0.0624 \text{ k/ft}^3) \\ &= 319.49 \text{ k} \end{aligned}$$

$$\begin{aligned} \text{Weight of seal} &= \text{buoyant weight of the seal} \\ &= (16')(20')(T' \text{ seal thickness})(0.150 - 0.0624 \text{ k/ft}^3) \\ &= 28.03(T) \text{ k/ft} \end{aligned}$$

$$\begin{aligned} \text{Pile displaced concrete} &= (12 \text{ pile})(0.785 \text{ ft}^2)(T')(0.150 - 0.0624 \text{ k/ft}^3) \\ &= 0.825(T) \text{ k/ft} \end{aligned}$$

$$\text{Bond on piles} = (12 \text{ pile})(\pi)(1')(6.5')(0.010 \text{ ksi})(144 \text{ in}^2/\text{ft}^2) = 352.86 \text{ k}$$

$$\text{Pile uplift capacity} = (12 \text{ pile})(10 \text{ k/pile}) = 120 \text{ k} < 352.86 \text{ k} \quad \text{use } 120 \text{ k}$$

$$\begin{aligned} \text{Uplift force} &= (\text{Seal weight}) - (\text{Pile disp. conc.}) + (\text{Pile uplift capacity}) \\ 319.49 \text{ k} &= 28.03(T) - 0.825(T) + 120 \end{aligned}$$

Solving for T:

$$T = 7.33' - \text{use } 7.5' \text{ seal thickness}$$

Note: F.S. = 1.0 for T = 7.33'

APPENDIX – SECTION 1 – GLOSSARY

A

Abutment - Supports at the end of the bridge used to retain the approach embankment and carry the vertical and horizontal loads from the superstructure. Current terminology is bent or end bent.

Access Control - The condition where the legal right of owners or occupants of abutting land to access a highway is fully or partially controlled by the Department of Transportation.

Advance Plans – 95-100% complete plans including special provisions, normally sent at 15 weeks.

Advertisement - The period of time between the written public announcement inviting proposals for projects and the opening of the proposals (bid or letting date).

Aggregate - Inert material such as sand, gravel, broken stone, or combinations thereof.

Aggregate, Coarse - Aggregates predominantly retained on the No. 4 sieve for portland cement concrete and those predominantly retained on the 1/4" for asphalt concrete.

Aggregate, Fine - Those aggregates which entirely pass the 3/8" sieve.

Aggregate, Dense Graded - A well-graded aggregate so proportioned as to contain a relatively small percentage of voids.

Aggregate, Open Graded - A well-graded aggregate containing little or no fines, with a relatively large percentage of voids.

Aggregate, Well-Graded - An aggregate possessing proportionate distribution of successive particle sizes.

Air-Entraining Agent - A substance used in concrete to increase the amount of entrained air in the mixture. Entrained air is present in the form of minute bubbles and improves the workability and frost resistance.

Allowable Headwater - The maximum elevation to which water may be ponded upstream of a culvert or structure as specified by law or design.

Allowable Span – The greatest horizontal distance permitted between supports.

Anchor Bolts - Bolts that are embedded in concrete which are used to attach an object to the concrete such as rail posts, bearings, steel girder-to-crossbeam connections, etc.

Annual Average Daily Traffic (AADT) – The average 24-hour traffic volume at a given location over a full 365 day year.

Anode - The positively charged pole of a corrosion cell at which oxidations occur.

Apron - The paved area between wingwalls at the end of a culvert.

Arch - A curved structure element primarily in compression, producing at its support reactions having both vertical and horizontal components.

Arch Pipe - A conduit in the form of a broad arch without a bottom.

Average Daily Traffic (ADT) - The average 24-hour traffic volume at a given location for some period of time, being the total volume during a stated period divided by the number of days in that period. Unless otherwise stated, the period is a year.

Axle Load - The load borne by one axle of a traffic vehicle.

Award - Written notification to the bidder that the bidder has been awarded a contract.

B

Backfill - Material used to replace or the act of replacing material removed during construction; also may denote material placed or the act of placing material adjacent to structures.

Backwater - The water upstream from an obstruction in which the free surface is elevation above the normal water surface profile.

Bar Chair - A device used to support horizontal reinforcing bars above the base of the form before the concrete is poured.

Bar Cutting Diagram - A diagram used in the detailing of bar steel reinforcement where the bar lengths vary as a straight line.

Base Course - The layer of specified material of designed thickness placed on a subbase or a subgrade to support a surface course.

Bascule Bridge - A bridge over a waterway with one or two leaves which rotate from a horizontal to a near-vertical position, providing unlimited clear headway.

Base Flood - Flood having 1% chance of being exceeded in any given year.

Battered Pile - A pile driven in an inclined position to resist horizontal forces as well as vertical forces.

Beam - Main longitudinal load carrying member in a structure, designed to span from one support to another (girder).

Bearings - Device to transfer girder reactions without overstressing the supports.

Bearing Capacity - The load per unit area which a structural material, rock, or soil can safely carry.

Bearing Failure - A crushing of material under extreme compressive load.

Bearing Seat - A prepared horizontal surface at or near the top of a substructure unit upon which the bearings are placed.

Bearing Stiffener - A stiffener used at points of support on a steel beam to transmit the load from the top of the beam to the support point.

Bedrock - The solid rock underlying soils or other superficial formation.

Bench Mark - A relatively permanent material object bearing a marked point whose elevation above or below an adopted datum is known.

Bent - Supports at the ends or intermediate points of a bridge used to retain approach embankments and/or vertical and horizontal loads from the superstructure.

Bicycle Lane - A lane in the traveled way designated for use by bicyclists.

Bicycle Path - A public way physically separated from the roadway, that is designated for use by bicyclists.

Bid Schedule - The list of bid items, their units of measurement, and estimated quantities, bound in the proposal booklet. (When a contract is awarded, the Bid Schedule becomes the Schedule of Contract Prices.)

Bidder - Any qualified individual or legal entity submitting a proposal in response to an advertisement.

Biennium - For the State of Oregon, a two-year period, always odd numbered years, starting July 1 and ending two years later on June 30.

Bleeding (Concrete) - The movement of mixing water to the surface of freshly placed concrete.

Bowstring Truss - A general term applied to a truss of any type having a polygonal arrangement of its top chord members conforming to or nearly conforming to the arrangement required for a parabolic truss.

Box Beam - A hollow structural beam with a square, rectangular, or trapezoidal cross-section.

Box Culvert - A culvert of rectangular or square cross-section.

Breakaway - A design feature that allows a device such as a sign, luminaire, or traffic signal support to yield or separate upon impact. The release mechanism may be a slip plane, plastic hinges, fracture elements, or a combination of these.

Bridge - A structure spanning and providing passage over a river, chasm, road, or the like, having a length of 20 feet or more from face to face of abutments or end bents, measured along the roadway centerline.

Bridge Approach - Includes the embankment materials and surface pavements that provide the transition between bridges and roadways.

Bridge End Panel - A reinforced concrete slab placed on the approach embankment adjacent to and usually resting upon the abutment back wall; the function of the approach slab is to carry wheel loads on the approaches directly to the abutment, thereby eliminating any approach roadway misalignment due to approach embankment settlement.

Bridging - A carpentry term applied to the cross-bracing fastened between timber beams to increase the rigidity of the floor construction, distribute more uniformly the live load and minimize the effects of impact and vibration.

Bridge Railing - A longitudinal barrier whose primary function is to prevent an errant vehicle from going over the side of the bridge structure.

Brush Curb - A curb 10" or less in width, which prevents a vehicle from brushing against the railing or parapet.

Buckle - To fail by an inelastic change in alignment as a result of compression.

Built-Up Member - A column or beam composed of plates and angles or other structural shapes united by bolting, riveting or welding.

Bulkhead – A partition built into wall forms to terminate each placement of concrete.

Buoyancy - Upward force exerted by the fluid in which an object is immersed.

Bushings - A lining used to reduce friction and/or insulate mating surfaces usually on steel hanger plate bearings.

Butt Splice - A splice where the ends of two adjoining pieces of metal in the same plane are fastened together by welding.

Butt Weld - A weld joining two abutting surfaces by combining weld metal and base metal within an intervening space.

C

Cable-Stayed Bridge - A bridge in which the superstructure is directly supported by cables, or stays, passing over or attached to towers located at the main piers.

CADD - Computer-Aided Design and Drafting.

Caisson - A watertight box of wood or steel sheeting; or a cylinder of steel and concrete, used for the purpose of making an excavation. Caissons may be either open (open to free air) or pneumatic (under compressed air).

Camber - A predetermined vertical curvature built into a structural member, to allow for deflection and/or vertical grade.

Cast-in-Place - The act of placing and curing concrete within formwork to construct a concrete element in its final position.

Catch Basin - A receptacle, commonly box shaped and fitted with a grided inlet and a pipe outlet drain, designed to collect the rain water and floating debris from the roadway surface and retain the solid material so that it may be periodically removed.

Catenary - The curve obtained by suspending a uniform rope or cable between two points.

Cathode - The negatively charged pole of a corrosion cell that accepts electrons and does not corrode.

Cathodic Protection - A means of preventing metal from corroding; this is done by making the metal a cathode through the use of impressed direct current and by attaching a sacrificial anode.

Catwalk - A narrow walkway to provide access to some part of a structure.

Chain Drag - A series of short medium weight chains attached to a T-shaped handle; used as a preliminary technique for inspecting a large deck area for delamination.

Chamfer – A beveled edge formed in concrete by a triangular strip of wood (chamfer strip) placed in a form corner.

Change Order - A written order issued by the Engineer to the Contractor modifying work required by the contract and establishing the basis of payment for the modified work.

Chord - A generally horizontal member of a truss.

Clay - Soil passing a No. 200 sieve that can be made to exhibit plasticity (putty-like properties) within a range of water contents.

Bridge Design Manual – June 2020
Oregon Department of Transportation
Section 1 – Design Standards

Clear Zone - Roadside border area, starting at the edge of the traveled way, that is available for safe use by errant vehicles. Establishing a minimum width clear zone implies that rigid objects and certain other hazards with clearances less than the minimum width should be removed and relocated outside the minimum clear zone, or remodeled to make breakaway, shielded, or safely traversable.

Closed Spandrel Arch - A stone or reinforced concrete arch span having spandrel walls to retain the spandrel fill or to support either entirely or in part the floor system of the structure when the spandrel is not filled.

Cobbles - Particles of rock, rounded or not, that will pass a 12" square opening and be retained on a 3" sieve.

Cofferdam - A barrier built in the water so as to form an enclosure from which the water is pumped to permit free access to the area within.

Cohesionless Soil - A soil that when unconfined has little or no strength when air-dried and that has little or no cohesion when submerged.

Cohesive Soil - A soil that when unconfined has considerable strength when air-dried and that has significant cohesion when submerged. Clay is a cohesive soil.

Commission - The Oregon Transportation Commission.

Composite Section - Two sections made of the same or different materials together to act as one integral section; such as a concrete slab on a steel or prestressed girder.

Compression Seals - A preformed, compartmented, elastomeric (neoprene) device, which is capable of constantly maintaining a compressive force against the joint interfaces in which it is inserted.

Concept Plans – plans to determine the basic features of a project including alignments, typical sections, slopes, preliminary drainage and TS&L bridge plans.

Concrete Overlay – 1.5" to 2" of concrete placed on top of the deck, used to extend the life of the deck and provide a good riding surface.

Contract - The written agreement between the Division and the Contractor describing the work to be done and defining the obligations of the Division and the Contractor.

Contract Plans - Detailed drawings and diagrams usually made to scale showing the structure or arrangement, worked out beforehand, to accomplish the construction of a project and/or object(s).

Contract Time - The number of calendar days shown in the proposal which is allowed for completion of the work.

Contraction Joint - A joint in concrete that does not provide for expansion but allows for contraction or shrinkage by the opening up of a crack or joint.

Contractor - The individual or legal entity that has entered into a contract with the Division.

Coordinates - Linear or angular dimensions designating the position of a point in relation to a given reference frame. It normally refers to the State Plane Coordinate System.

Core - A cylindrical sample of concrete removed from a bridge component for the purpose of destructive testing.

Counterfort Wall - A reinforced concrete retaining wall whose vertical stem has triangular-shaped ribs

projecting into the soil and spaced at regular intervals to provide strength and stability.

Crash Cushion - An impact attenuator device that prevents an errant vehicle from impacting fixed object hazards by gradually decelerating the vehicle to a safe stop or by redirecting the vehicle away from the hazard.

Crash Tests - Vehicular impact tests by which the structural and safety performance of roadside barriers and other highway appurtenances may be determined. Three evaluation criteria are considered, namely (1) structural adequacy, (2) impact severity, and (3) vehicular post-impact trajectory.

Creep - Time dependent inelastic deformation under elastic loading of concrete or steel resulting solely from the presence of stress.

Cross-bracing - Bracing used between stringers and girders to hold them in place and stiffen the structure.

Cross-section - The exact image formed by a plane cutting through an object usually at right angles to a central axis.

Crown Section - Roadway section with the height of the center of the roadway surface above its gutters.

Culvert - Federal Highway Administration definition: "A structure not classified as a bridge having a span of 20 feet or less spanning a watercourse or other opening on a public highway"; a conduit to convey water through an embankment.

Curb - A vertical or sloping member along the edge of a pavement or shoulder forming part of a gutter, strengthening or protecting the edge, and clearly defining the edge of vehicle operators. A curb is a horizontal offset varying from 10" to less than 18". The surface of the curb facing the general direction of the pavement is called the "face".

Curing - The preparation of a material by chemical or physical processing for keeping or use; treating concrete by covering its surface with some material to prevent the rapid evaporation of water.

Cut-Off-Wall - A wall built at the end of a culvert apron to prevent the undermining of the apron.

D

Dead End - End of post-tensioned bridge where tendons are anchored but no jacking takes place (opposite of jacking end).

Dead Load - Structure weight including future wearing surface on deck and attachments.

Deadman - A concrete mass, buried in the earth behind a structure, that is used as an anchor for a rod or cable to resist horizontal forces that act on the structure.

Deformed Bars - Concrete reinforcement consisting of steel bars with projections or indentations to increase the mechanical bond between the steel and concrete.

Delamination - Subsurface separation of concrete into layers.

Department - The Department of Transportation of the State of Oregon.

Design Volume or Design Hourly Volume - A volume determined for use in design representing traffic expected to use the highway. Unless otherwise stated, it is an hourly volume.

Diaphragm - Structural: A structural member used to tie adjoining girders together and stiffen them in a lateral direction as well as to distribute loads.

Diamond Grinding - Process to abrade or remove a surface, such as concrete, by the cutting action of rotating circular blade with diamond-tipped teeth.

Direct Tension Indicator - Load-indicating washer for bolts.

Doby - A precast block of concrete of various sizes used to support or provide clearances between reinforcing bars and formwork.

Dolphins - A group of piles or sheet piling driven adjacent to a pier. Their purpose is to prevent extensive damage or possible collapse of a pier from a collision with a ship or barge.

Draped Strands - Strand pattern for prestressing strands, where strands are draped to decrease the prestressing stress at the ends of the girder where the applied moments are small.

Drift Pin - A metal pin, tapered at both ends, used to draw members of a steel structure together by being driven through the corresponding bolt holes.

Drip Groove - A groove formed into the underside of a projecting concrete sill or coping to prevent water from following around the projection.

E

E - modulus of elasticity of a material; the stiffness of a material.

E&C – Engineering & Contingencies. Engineering costs are ODOT's costs to administer the construction contract. Contingencies are unforeseen costs due to construction extra work price agreements or types of problems caused by weather, accidents, etc. by the contract pay item.

Elastomeric Bearing Pads - Pads ½" and less in thickness made of all rubber-like material that supports girders and concrete slabs; pads over ½" in thickness consist of alternate laminations of elastomer and metal.

End-Bearing Pile - A pile which provides support primarily due to reaction at its tip.

Environmental Classes – Classes (1, 2 or 3) that ????????

Environmental Class I Environmental Impact Statement: Projects that normally involve significant changes in traffic capacities and patterns. These projects generally involve major right-of-way acquisitions. Both draft and final Environmental Impact Statements are required.

Environmental Class II Categorical Exclusions: Projects that normally involve the improvement of pavement conditions on traffic safety, but little, if any, change in traffic capacities or patterns. Right-of-way requirements must be minor. These projects are categorically excluded from further environmental documentation, unless permit requirements indicate otherwise.

Environmental Class III Environmental Assessment: Projects that do not clearly fall within Class I or Class II. These projects require assessments to determine their environmental significance.

Epoxy - A synthetic resin which cures or hardens by chemical reaction between components which are mixed together shortly before use.

Epoxy Coated Rebar - Steel reinforcement coated with a powdered epoxy resin, to prevent corrosion of the bar steel.

Expansion Bearings - Bearings that allow longitudinal movement of the superstructure relative to the substructure and rotation of the superstructure relative to the substructure.

Expansion Device - A device placed at expansion points in bridge superstructures to carry the vertical bridge loads without preventing longitudinal movement.

Expansion Joint - A joint in concrete that allows expansion due to temperature changes, thereby preventing damage to the structure.

Extra Work - Work not included in any of the contract items as awarded but determined by the Engineer necessary to complete the project according to the intent of the contract. This may be paid on a negotiated price, force account, or established price basis.

Extrados - The curved edge of an arch rib or barrel formed by the intersection of the top and side arch surfaces.

F

Falsework - In general, a temporary construction work on which a main or permanent work is wholly or partially supported until it becomes self-supporting. For cast-in-place concrete or steel construction, it is a structural system to support the vertical and horizontal loads from forms, reinforcing steel, plastic concrete, structural steel, and placement operations.

Fatigue - The tendency of a member to fail at a lower stress when subjected to cyclical loading than when subjected to static loading.

Fatigue Crack - Any crack caused by repeated cyclic loading.

Federal-Aid System of Highways - The national system of interstate highways, Federal-aid highway system, system of secondary and feeder roads, Federal-aid grade crossing projects, federal forest highway systems and projects and other highway and related projects, all within the meaning of the Federal-Aid Road Act (1916), and all acts amendatory thereof and supplementary thereto, and the federal regulations issued under such acts.

Fender - A structure that acts as a buffer to protect the portions of a bridge exposed to floating debris and water-borne traffic from collision damage.

Fiscal Year - For the State of Oregon, July 1 through June 30 of the next year; for the Federal government, October 1 through September 30 of the next year. The Federal fiscal year (FY) is broken into quarters:
F1Q (October, November, December)
F2Q (January, February, March)
F3Q (April, May, June)
F4Q (July, August, September)

Felloe Guard - Timber curb, usually 10" x 12", bolted to timber deck and timber rail post. Sometimes called wheel guard.

Filler Plate - A steel plate or shim used for filling in space between compression members.

Fixed Bearings - Bearings that do not provide for any longitudinal movement of the superstructure relative to the substructure, but allows for rotation of the superstructure relative to the substructure.

Flat Slab - A reinforced concrete superstructure that has a uniform depth throughout.

Flood Plain - An area that would be inundated by a flood.

Floodway - A stream channel plus any adjacent flood plain areas that must be kept free of encroachment so that the 100-year flood can be conveyed without substantial increases in flood heights.

Floor Beam - A transverse structural member that extends from truss to truss or from girder to girder across the bridge.

Flux - A material that protects the weld from oxidation during the fusion process.

Force Account Work - Items of extra work ordered by the Engineer that are to be paid for by material, equipment, and labor.

Forms - A structural system constructed of wood or metal used to contain the horizontal pressures exerted by plastic concrete and retain it in its desired shape until it has hardened.

Fracture Critical Members - Members of a bridge where a single fracture in a member can lead to collapse.

Fracture Mechanics - Study of crack growth in materials.

Free-Standing Retaining Wall – A retaining wall that is not part of the bridge abutment walls.

Friction Pile - A pile that provides support through friction resistance along the surface area of the pile.

Functionally Obsolete Bridges - Those bridges which have deck geometry, load carrying capacity (comparison of the original design load to the current state legal load), clearance, or approach roadway alignment which no longer meet the usual criteria for the system of which they are a part as defined by the Federal Highway Administration.

G

Gabions - Rock-filled wire baskets used to retain earth and provide erosion control.

Galvanic Action - Electrical current between two unlike metals.

Galvanize - To coat with zinc.

Geotextiles - Sheets of woven or non-woven synthetic polymers or nylon used for drainage and soil stabilization.

Girder - Main longitudinal load carrying member in a structure (beam).

Glare Screen - A device used to shield a driver's eye from the headlights of an oncoming vehicle.

Grade Separation - A crossing of two highways or a highway and a railroad at different levels.

Gravity Wall - A retaining wall that is prevented from overturning by its weight alone.

Green Concrete - Concrete that has set but not appreciably hardened.

Grid Flooring - A steel floor system comprising a lattice pattern which may or may not be filled with concrete.

Grout - A mixture of cementitious material and water having a sufficient water content to render it a free-flowing mass, used for filling (grouting) the joints in masonry, for fixing anchor bolts and for filling post-tensioning ducts.

H

Hammerhead Pier - A pier that has only one column with a cantilever cap and is somewhat similar to the shape of a hammer.

Hanger Plate - A steel plate that connects the pins at hinge points thus transmitting the load through the hinge.

Haunch - An increase in depth of a structural member usually at points of intermediate support.

Haunched Slab - A reinforced concrete superstructure that is haunched (has an increased depth) at the intermediate supports.

Headwall - A concrete structure at the ends of a culvert to retain and protect the embankment slopes, anchor the culvert, and prevent undercutting.

High Performance Concrete (HPC) – Concrete with enhanced properties including higher strength, greater durability and decreased permeability.

High Performance Steel (HPS) - Steel with enhanced properties including increased durability and weldability.

Hinge - A device used to hold the ends of two adjoining girders together, but does not allow for longitudinal movement of the superstructure. A point in a structure where a member is free to rotate.

Holddown Device - A device used on bridge abutments to prevent girders from lifting off their bearings as a result of the passage of live load over the bridge.

Honeycomb - A surface or interior defect in a concrete mass characterized by the lack of mortar between the coarse aggregate particles.

Howe truss - A truss of the parallel chord type with a web system composed of vertical (tension) rods at the panel points with an X pattern of diagonals.

Hydration - The process by which cement combines with water to form a hard binding substance.

Hybrid Girder - A steel plate girder with the web steel having a lower yield strength than the steel in one or both flanges.

Hydrodemolition - Process to abrade or remove a surface, such as concrete, by streams of water ejected from a nozzle at high velocity.

I

Incidental Work - Work necessary for fulfillment of the contract but which is not listed as a pay item in the contract and for which no separate or additional payment will be made.

Bridge Design Manual – June 2020
Oregon Department of Transportation
Section 1 – Design Standards

Initial Set (Concrete) - Initial stiffening of concrete, with time based upon penetration of a weighted test needle. In the field, it is commonly assumed to be the time when the dead weight of vibrator does not penetrate into the concrete.

Inlet Control - The case where the discharge capacity of a culvert is controlled at the culvert entrance by the depth of headwater and the entrance geometry, including barrel shape, cross-sectional area, and inlet edge.

Intermediate Stiffener - A vertical transverse steel member used to stiffen the webs of plate girders between points of support.

Internal File Number - Number assigned by the Bridge Front Office as part of office automation (computerized files) and used to track all files.

Invert - The bottom or lowest point of the internal surface of the transverse cross-section of a pipe.

Inventory Rating (Design Load) - Load level that produces normal design stresses in the structures. The inventory rated load is the load that can safely utilize an existing structure for an indefinite period of time.

International System of Units (SI) - The modernized metric system.

Intrados - The curved edge of an arch rib or barrel formed by the intersection of the bottom and side arch surfaces.

Isotropic - Have the same material properties in all directions, e.g., steel.

J

Jacking End - End of post-tensioned bridge where jacking takes place (opposite of dead end).

Jetting - Forcing water into holes in an embankment to settle or to compact the earth. Forcing water through holes in piles to install the piles to a specified depth before driving.

K

Key Number - Number assigned to a project by Program Section to identify it in the Project Control System (PCS). All structures in a project have the same key number.

Kilogram (kg) - The base unit for mass in the International System of Units (metric).

King Post Truss - Two triangular panels with a common center vertical; the simplest of triangular trusses.

L

Lacing - Small flat plates used to connect individual sections of built up members.

Laitance - A weak mortar that collects at the surface of freshly placed concrete, usually caused by an excess of mixing water or by excessive finishing.

Lamellar Tear - Incipient cracking between the layers of the base material (steel).

Bridge Design Manual – June 2020
Oregon Department of Transportation
Section 1 – Design Standards

Lateral Bracing - Bracing placed in a horizontal plane between steel girders near the bottom and/or top flanges.

Latex Modified Concrete (LMC) - Emulsion of synthetic rubber or plastic obtained by polymerization used as a concrete additive to decrease permeability.

Leaf - The movable portion of a bascule bridge which forms the span of the structure.

Lenticular Truss - A truss having parabolic top and bottom chords curved in opposite directions with their ends meeting at a common joint; also known as a fish belly truss.

Level of Performance - The degree to which a longitudinal barrier, including bridge railing, is designed for containment and redirection of different types of vehicles.

Liquid Penetrant Inspection - Nondestructive inspection process for testing for continuities that are open to the surface, by using a liquid dye.

Live Load - Force of the applied moving load of vehicles and/or pedestrians.

Load Rating - Evaluation of the safe live load capacity of the weakest member of a bridge.

LRFD - Load Resistance Factor Design.

Longitudinal Stiffener - A longitudinal steel plate (parallel to girder flanges) used to stiffen the webs of welded plate girders. Normally thicker webs are used to eliminate longitudinal stiffeners.

Low Relaxation Strands - Prestressing tendons that are manufactured by subjecting the strands to heat treatment and tensioning causing a permanent elongation. This increases the strand yield strength and reduces strand relaxation under constant tensile stress.

M

Magnetic Particle Inspection (MT) - Nondestructive inspection process for testing for the location of surface cracks or surface discontinuities, by applying dry magnetic particles to a weld area or surface area that has been suitably magnetized.

Microsilica (Silica Fume) (MC) - Very fine non-crystalline silica used as an admixture in concrete to improve the strength, permeability and abrasion resistance.

Minor Structure Concrete (MSC) - Nonstructural concrete furnished according to contractor proportioning, placed in minor structures and finished as specified. Previously called commercial concrete.

Modular Expansion Joints - Multiple, watertight joint assemblies for bridges requiring expansion movements greater than 4 inches.

Mud Sill - A timber platform laid on earth as a support for vertical members or bridge falsework.

Mylars - Full-size drawings on mylar. The final "legal" drawing used for signatures and printing contract plans.

N

NDT - Nondestructive testing, a method of checking the structural quality of materials that does not damage them.

Negative Moment - The moment causing tension in the top fibers and compression in the bottom fibers of a structural member.

Negative Reinforcement - Reinforcement placed in concrete to resist negative bending moments.

Newton (N) - The derived unit for force (mass times acceleration or kg times m/s^2) in the International System of Units (metric).

Nominal - Used to designate a theoretical dimension, size, or slope that may vary from the actual by a very small or negligible amount. Example: a 1" nominal diameter steel pipe has an actual 0.957" inside diameter.

Nominal Pile Resistance – LRFD term for the maximum axial pile bearing resistance. Equivalent to the ultimate pile capacity term used in allowable stress design.

Non-Redundant Structure - Type of structure with single load path, where a single fracture in a member can lead to the collapse of the structure.

Nosing – A bulkhead at the ends of bridges or at expansion joints made of a durable material to protect and reinforce the slab edge. It also provides a smooth edge or surface at expansion joints to facilitate installation and provide a better seal.

O

Operating Rating (Permit Loads) - The absolute maximum permissible stress level to which a structure may be subjected. It is that stress level that may not be exceeded by the heaviest loads allowed on the structure. Issue special permits for heavier than normal vehicles only if such loads are distributed so as not to produce stress in excess of the operating stress.

Outlet Control - The case where the discharge capacity of a culvert is controlled by the elevation of the tail water in the outlet channel and the slope, roughness, and length of the culvert barrel, in addition to the cross-sectional area and inlet geometry.

Orthotropic - A description of the physical properties of a material that has pronounced differences in two or more directions at right angles to each other.

P

Parapet - A low concrete rail designed and placed to prevent traffic from passing over the edge of a bridge deck or end of box culvert.

Pascal (Pa) - The derived unit for pressure or stress ($Pa=N/m^2$) in the International System of Units (metric).

Paving Dam – (see Nosing) - – A bulkhead at the ends of bridges or at expansion joints made of a durable material to protect and reinforce the slab edge and provide a stopping place for the wearing surface.

Paving Ledge – A ledge or corbel attached to the end beam of a bridge, to provide support for a current or

future end panel.

Performance Level - See Level of Performance.

Pier - Intermediate substructure unit of a bridge. Current terminology is bent.

Pile - A long, slender piece of wood, concrete, or metal to be driven, jettied, or cast-in-place into the earth or river bed to serve as a support or protection.

Pile Bent - A pier where the piles are extended to the pier cap to support the structure.

Pile Cap - A member, usually of reinforced concrete, covering the tops of a group of piles for the purpose of tying them together and transmitting to them as a group the load of the structure that they support.

Pipe Arch - A conduit in the form of a broad arch with a slightly curved integral bottom.

Plastic Deformation - Deformation of material beyond the elastic range.

Positive Moment - In a girder the moment causing compression in the top flange and tension in the bottom flange.

Post-Tensioning - Method of prestressing in which the tendon is tensioned after the concrete has cured.

Pot Bearing - A bearing type that allows for multi-directional rotation by using a neoprene or spherical bearing element.

Prestress Camber - The deflection in prestressed girders (usually upward) due to the application of the prestressing force.

Pratt Truss - A truss with parallel chords and a web system composed of vertical posts with diagonal ties inclined outward and upward from the bottom chord panel points toward the ends of the truss; also known as N-truss.

Preliminary Plans – 85-90% complete plans, normally sent at 20 weeks.

Prestressed Concrete - Concrete in which there have been introduced internal stresses (normally pretensioned steel) of such magnitude and distribution that the stresses resulting from given external loadings are counteracted to a desired degree

Pretensioned - Any method of prestressing in which the strands are tensioned before the concrete is placed.

Project Manager - The Engineer's representative who directly supervises the engineering and administration of a contract.

Proposal - A written offer by a bidder on forms furnished by the Division to do stated work at the prices quoted.

PS&E - Literally, Plans, Specifications, and Estimates. Usually it refers to the time when the plans, specifications, and estimates on a project have been completed and referred to FHWA for approval. When the PS&E has been approved, the project goes from the preliminary engineering phase to the construction phase.

Pumping - The ejection of mixtures of water, clay and/or silt along or through transverse or longitudinal joints, crack or payment edges, due to vertical movements of the roadway slab under traffic.

Q

Queen-post Truss - A parallel chord type of truss having three panels with the top chord occupying only the length of the center panel; unless center panel diagonals are provided, it is a trussed beam.

R

Radiographic Inspection - Nondestructive inspection process where gamma rays or X rays pass through the object and cast an image of the internal structure onto a sheet of film as the result of density changes.

Redundant Structure - Type of structure with multiple-load paths where a fracture in a single member cannot lead to the collapse of the structure.

Reflection Crack - A crack appearing in a resurfacing or overlay caused by movement at joints or cracks in the underlying base or surface.

Rehabilitation – Work required to restore the structural integrity of a bridge, or bridge element, as well as work necessary to correct major safety defects. Rehabilitation activities are considered bridge preservation.

Reinforced Pile Tip - Metal reinforcement fastened to the pile tip to protect it during driving.

Replacement – Total reconstruction of a structurally deficient or functionally obsolete bridge, or bridge element, with a new one constructed in the same vicinity. The replacement structure, or element, must comply with current design codes, policies and practices.

Residual Camber - Camber due to the prestressing force minus the dead load deflection of the girder.

Retrofit – Work required to upgrade a bridge, or bridge element, beyond its original intended purpose and design capacity. This work often includes strengthening to add structural capacity.

Right of Way - Land, property, or property interest, usually in a strip, acquired for or devoted to transportation purposes.

Riprap - A facing of stone used to prevent erosion. It is usually dumped into place, but is occasionally placed by hand.

Roadside Barrier - A longitudinal barrier used to shield roadside obstacles or non-traversable terrain features. It may occasionally be used to protect pedestrians from vehicle traffic.

Roadway - The portion of a highway, including shoulders, for vehicular use.

Rubble - Irregularly shaped pieces of varying size stone in the undressed condition obtained from a quarry.

S

Sacrificial Anode - The anode in a cathodic protection system.

Sand - Particles of rock that will pass a No. 4 sieve and be retained on a No. 200 sieve.

Scaffolding - Temporary elevated walkway or platform to support workmen, materials and tools.

Bridge Design Manual – June 2020
Oregon Department of Transportation
Section 1 – Design Standards

Scarify - To loosen, break up, tear up, and partially pulverize the surface of soil, or of a road.

Scour - Erosion of a river bed area caused by water flow.

Scour Protection - Protection of submerged material by steel sheet piling, riprap, mattress, or combination of such methods.

Screeding - The process of striking off excess material to bring the top surface to proper contour and elevation.

Seal - A concrete mass (usually not reinforced) poured under water in a cofferdam that is designed to resist hydrostatic uplift. The seal facilitates construction of the footing in dry conditions.

Shear Connector - A connector used to joint cast-in-place concrete to a steel section and to resist the shear at the connection.

Shear Lag - Nonuniform stress pattern due to ineffective transmission of shear.

Shed Roof - Roadway section with the height of one gutter greater than the centerline and other gutter.

Sheet Pile - A pile made of flat or arch cross-section to be driven into the ground or stream bed and meshed or interlocked with like members to form a wall, or bulkhead.

Sheet Pile Cofferdam - A wall-like barrier composed of driven piling constructed to surround the area to be occupied by a structure and permit dewatering of the enclosure so that the excavation may be produced in the open air.

Shoofly - Detour alignment of temporary railroad track and bridge around the site of a permanent railroad bridge replacement.

Shotcrete - Mortar or concrete pneumatically projected at high velocity onto a surface.

Shoulders - The portions of the roadway between the traveled way and the inside edges of slopes of ditches or fills, exclusive of auxiliary lanes, curbs, and gutters.

Shy Distance (E-Distance) - The distance from the edge of the traveled way beyond which a roadside object will not be perceived as an immediate hazard by the typical driver, to the extent that the vehicle's placement or speed will be changed.

Shrinkage - Contraction of concrete due to drying and chemical changes, dependent on time.

Silt - Soil passing a No. 200 sieve that is non-plastic or exhibits very low plasticity.

Simple Spans - Spans with the main stress carrying members non-continuous, or broken, at the intermediate supports.

Skew or Skew Angle - The acute angle formed by the intersection of a line normal to the centerline of the roadway with a line parallel to the face of the abutments or piers, or in the case of culverts with the centerline of the culverts. Left hand forward skew indicates that, look up station, the left side of the structure is further up station than the right hand side. Right hand skew indicates that the right side of structure is further up station than the left side.

Slip Base - A structural element at or near the bottom of a post or pole that will allow release of the post from its base upon impact while resisting wind loads.

Slope - The degree of inclination to the horizontal. It is sometimes described by such adjectives as steep,

moderate, gentle, mild or flat.

Slope Paving - Pavement placed on the slope in front of abutment to prevent soil erosion.

Soffit - The bottom surface of a beam or an arch rib or barrel.

Spandrel - The area between the roadway and the arch in the side view of an arch bridge.

Special Provisions - The special directions, provisions, and requirements peculiar to the project that augment the standard specifications. They are commonly referred to as “specials”.

Specifications - The body of directions, provisions, and requirements, together with written agreements and all documents of any description, made or to be made, pertaining to the method or manner of performing the work, the quantities, and the quality of materials to be furnished under the contract.

Spread Footing - A footing that is supported directly by soil or rock.

Spur Dike - A wall or mound built or extended out from the upstream side of an abutment used for training the stream flow to prevent erosion of stream bank. May also be used where there is no bridge, but the stream flows along the side of highway embankment.

Stainless Steel Teflon Bearings - Incorporated stainless steel and teflon with steel to provide the necessary expansion movement.

St. Venant Torsion - Uniform torsion resulting in no deformation of the cross-section.

State Plane Coordinates - The plane-rectangular coordinate system established by the United States Coast and Geodetic Survey. Plane coordinates are used to locate geographic position.

Station - A distance of 100 feet measured horizontally.

Stirrup - Vertical U-shaped or rectangular shaped bars placed in concrete beams to resist the shearing stresses in the beam.

Strengthening – Work to add structural capacity to a bridge element or structure.

Stress Relieved Strands - Any prestressing tendons that are manufactured by relieving the high residual stresses that were introduced into the steel during the wire drawing and stranding operations. Stress relieving is not a heat treatment and does not change the strand yield strength.

Strip Seal Joint - Molded neoprene glands inserted and mechanically locked between armored interfaces of extruded steel sections.

Structurally Deficient Bridges - Those bridges which have been (1) restricted to light vehicles only, (2) closed, or (3) require immediate rehabilitation to remain open, as defined by the Federal Highway Administration.

Subgrade - The top surface of completed earthwork on which subbase, base, surfacing, pavement, or a course of other material is to be placed.

Substructure - Those parts of a structure which support the superstructure, including bents, piers, abutments, and integrally built wingwalls, up to the surfaces on which bearing devices rest. Substructure also includes portions above bearing surfaces when those portions are built integrally with a substructure unit (e.g. backwalls of abutments). When substructure and superstructure elements are built integrally, the division between substructure and superstructure is considered to be at the bottom soffit of the longitudinal or transverse beam, whichever is lower. Culverts and rigid frames are considered to be entirely

substructure.

Sufficiency Rating - A method of evaluating data by calculating four separate factors to obtain a numeric value which is indicative of bridge sufficiency to remain in service. The result of this method is a percentage in which 100 percent would represent an entirely sufficient bridge and zero percent would represent an entirely insufficient or deficient bridge.

Superelevation - The difference in elevation between the inside and outside edges of a roadway in a horizontal curve; required to counteract the effects of centrifugal force.

Superplasticizer - A high range water-reducing admixture that increases the slump of freshly mixed concrete without increasing the water content.

Superstructure - Those parts of a structure above the substructure, including bearing devices.

Surcharge - Any load that causes thrust on a retaining wall, other than backfill to the level of the top of the wall. Also preloading of an embankment to minimize the time for initial consolidation of the subsurface soils.

Suspension Bridge - A bridge in which the floor system is supported by catenary cables which are supported upon towers and are anchored at their extreme ends.

Suspender - A wire cable, metal rod or bar connected to a catenary cable of a suspension bridge at one end and the bridge floor system at the other, thus transferring loads from the roadway to the main suspension members.

T

Tack Welds - Small welds used for temporary connections.

Telltale (Tattletale) - Any device designed to indicate movement of formwork or falsework.

Tendon - A name for prestressed reinforcing element whether wires, bars, or strands.

Tenon - A constant diameter extension welded to the tip of the tapered metal arm of a luminaire support pole to receive the luminaire.

Thixotropy - Property of a material that enables it to stiffen in a short period on standing, but to acquire a lower viscosity again on mechanical agitation. A property desirable for post-tensioning duct grout.

Three-Dimensional Finite Element Analysis - Analysis in which a three-dimensional continuum is modeled as an assemblage of discrete elements in three-dimensional space.

Three-Hinged Arch - An arch which is hinged at each support and at the crown.

Through Structure - A structure that has its floor connected to the lower portion of the main stress-carrying members, so that the bracing goes over the traffic. A structure whose main supporting members project above the deck or surface.

Tining - Is used on finished concrete deck or slab surfaces to provide friction and reduce hydroplaning. Grooves are placed in the plastic concrete or cut into the hardened concrete.

Torsional Stress - Shear stress on a transverse cross-section resulting from a twisting action.

Transformed Section - A hypothetical section of one material so as to have the same elastic properties as a section of two materials.

Transition - A section of barrier between two different barriers or, more commonly, where a roadside barrier is connected to a bridge railing or to a rigid object such as a bridge pier. The transition should produce a gradual stiffening of the approach rail so vehicular pocketing, snagging, or penetration at the connection can be avoided.

Traveled Way - The portion of the roadway for the movement of vehicles, exclusive of shoulders and auxiliary lanes.

Tremie - A pipe or tube through which concrete is deposited underwater.

Trial Batch - A batch of concrete prepared to establish or check proportions of the constituents.

Turnbuckle - A long, cylindrical, internally threaded nut used to connect the elements of adjustable rod and bar members.

Turn-of-the-Nut - A bolt-tightening method.

Two-hinged Arch - A rigid frame which may be arch-shaped or rectangular but is hinged at both supports.

U

Ultrasonic Inspection - A non-destructive inspection process where by an ultra-high frequency sound wave induced into a material is picked up in reflection from any interface or boundary.

Unbonded Strands - Strands so coated as to prevent their forming a bond with surrounding concrete. Used to reduce stress at the ends of a member.

Underpinning - The addition of new permanent support to existing foundations to provide additional capacity.

Uplift - A force tending to raise a structure or part of a structure and usually caused by wind and/or eccentric loads, or the passage of live-load over the structure.

Utility - A line, facility, or system for producing, transmitting, or distributing communications, power, electricity, heat, gas, oil, water, steam, waste, storm water not connected with highway drainage, or any other similar commodity which directly or indirectly serves the public. The term utility shall also mean the utility company, district, or cooperative, including any wholly owned or controlled subsidiary.

V

Vierendeel Truss - A Pratt truss without diagonal members and with rigid joints between top and bottom chords and the verticals.

Vibrator - An oscillating device inserted at selected locations to consolidate fresh concrete.

W

Bridge Design Manual – June 2020
Oregon Department of Transportation
Section 1 – Design Standards

Wales - Horizontal support members in close contact with a row of sheet piles in a cofferdam or shoring wall. Sometimes called whalers.

Warrants - The criteria by which the need for a safety treatment or improvement can be determined.

Warren Truss - A triangular truss consisting of sloping members between the top and bottom chords and no verticals; members form the letter W.

Water/Cement Ratio - The weight of water divided by the weight of cement in a concrete; ratio controls the strength of the concrete.

Waterproofing Membranes - Impervious material overlaid with bituminous concrete to protect decks from the infiltration of chlorides and resulting deterioration.

Wearing Surface - The top layer of a pavement designed to provide structural values and a surface resistant to traffic abrasion.

Weep Hole - A drain hole through a wall to prevent the building up of hydraulic pressure behind the wall.

Weld Inspection - Covers the process, written procedure, and welding in process. Post weld heat maintenance if required, post weld visual inspection and non-destructive testing as specified in contract and Standard Specifications.

Welded-Wire Fabric - A two-way reinforcing mat, fabricated from cold-drawn steel wire, having parallel longitudinal wires welded at regular intervals to parallel transverse wires.

Well-Graded - An aggregate possessing a proportionate distribution of successive particle sizes.

Wetlands - Areas that are inundated or saturated by surface or ground water at a frequency and duration sufficient to support, and that under normal circumstances do support, vegetation typically adapted for life in saturated soil conditions. Wetlands generally include swamps, marshes, bogs, and similar areas.

Wheel Load – Half of an axle load.

Wingwall - A wall attached to the abutments of bridges or box culverts retaining the roadway fill. The sloping retaining walls on each side of the center part of a bridge abutment.

X

Y

Yield - Permanent deformation (permanent set) which a metal piece takes when it is stressed beyond the elastic limit.

Young's Modulus - modulus of elasticity of a material (E); or the stiffness of a material.

Z

APPENDIX – SECTION 1 – ABBREVIATIONS (INITIALISMS AND ACRONYMS)

A

A&E	Architectural and Engineering
AADT	Annual Average Daily Traffic
AASHO	American Association of State Highway Officials (1921-1973)
AASHTO	American Association of State Highway and Transportation Officials (since 1973)
AB	Anchor bolt
AC	Asphalt Concrete
ACEC	American Council of Engineering Companies of Oregon
ACI	American Concrete Institute
ACP	Asphalt Concrete Pavement
ACT	Area Commission on Transportation
ACWS	Asphalt concrete wearing surface
ADA	Americans with Disabilities Act
ADT	Average daily traffic (see Definitions)
ADTT	Average Daily Truck Traffic
AEE	Association of Engineering Employees
AGC	Associated of General Contractors of America
AISC	American Institute of Steel Construction
AISI	American Iron and Steel Institute
AITC	American Institute of Timber Construction
a.k.a.	Also known as
AML	Automated Milepoint Log
AMT	Area Management Team
ANSI	American National Standards Institute
AOC	Association of Oregon Counties
AOH	Access Oregon Highways
A.P.	Angle Point
APA	American Plywood Association
API	Area of Potential Impact
APWA	American Public Works Association
AREA	American Railway Engineering Association
ARRA	American Response and Recovery Act
ARS	Accident Records System (Accident Data Unit, Transportation Research Section)
ARTBA	American Road and Transportation Builders Association
ASAP	As soon as possible
ASCE	American Society of Civil Engineers
ASCII	American Standard Code for Information Interchange (refers to files that are pure text)
ASTM	American Society for Testing and Materials
ATA	Agreement to Agree
ATC	Applied Technology Council
ATR	Automatic Traffic Recorder
ATPM	Asphalt-treated permeable material
AWPA	American Wood Products Association
AWS	American Welding Society

B

B-Team	Team of Bridge Engineering Section Supervisors & Engineers
BAMS	Bid Analysis Management System
BBS	Bulletin Board System (computers)
BDS	Bridge Design System (AASHTO software)
BDS	Bridge Data System (ODOT software)
BDWO	Bridge Design Work Order
BIOS	Basic Input/Output System (computers)
BLM	Bureau of Land Management (U.S. Dept. of Interior)

Bridge Design Manual – June 2020
Oregon Department of Transportation
Section 1 – Design Standards

BLT	Bridge Leadership Team
BMP	Best Management Practice
BMS	Bridge Management System
BNRR	Burlington Northern Railroad
Bot.	Bottom
BPR	Bureau of Public Roads (now FHWA)
BRASS	Bridge Rating and Analysis of Structural Systems (software)
BRSFUP	Bridge Rail Safety Features Upgrade Program
Bt.	Bent
BUBB	Bargaining Unit Benefit Board
BVC	Begin vertical curve

C

C	Degrees Celsius
CAC	Citizens Advisory Committee or Community Action Committee
CAD	Computer-aided drafting/computer-aided design
CADD	Computer-aided drafting and design
CAE	Computer-aided engineering
CalTrans	California Department of Transportation
CCT	Concrete Control Technician
CETAS	Collaborative Environmental and Transportation Agreement for Streamlining
CD-ROM	Compact Disk - Read-Only Memory
CF	Cubic feet
CFS	Cubic Feet per Second
CG	Center of Gravity
CICS	Customer Information and Control System (Transportation inventory and Mapping Unit software on the mainframe)
CIM	Corporate Information Management
CIP	Cast-in-place
CIS	Career Information System (Training & Employee Development Sect.)
CLT	Construction Leadership Team
CMP	Construction Mitigation Plan Construction Management Plan Corrugated metal pipe
COGO	Coordinate Geometry language
COM	Communications port (serial port on a computer)
CP	Cathodic protection
CPM	Critical Path Method (method of scheduling) Consultant Project Manager
CPU	Central Processing Unit (computers)
CQC	Complete Quadratic Combination (method of combining seismic forces or displacements)
CRF	Code of Federal Regulations
CRSI	Concrete Reinforcing Steel Institute
CRT	Cathode Ray Tube display (monitor)
CS ³	Context Sensitive and Sustainable Solutions
CTP	Continuous Trip Permit
CY	Cubic yard
CZM	Coastal Zone Management

D

DAP	Design Acceptance Plans
DAW	Design Acceptance Workshop
DB	Design-Build
DBA	Doing Business As
DBE	Disadvantaged Business Enterprises

Bridge Design Manual – June 2020
Oregon Department of Transportation
Section 1 – Design Standards

DEC	Digital Equipment Corporation
DEIS	Draft Environmental Impact Statement
DEQ	Department of Environmental Quality (Oregon)
DHV	Design hourly volume
Dia.	Diameter
DL	Dead load
DLCD	Department of Land Conservation and Development (Oregon) (formerly LCDC)
DLT	Discipline Leadership Team
DOGAMI	Department of Geology and Mineral Industries (Oregon)
DM	District Manager
DMS	District Maintenance Supervisor (old)
DMV	Division of Motor Vehicles
DOJ	Department of Justice
DOS	Disk Operating System for personal computers
DS	Top of deck to streambed distance
DSL	Division of State Lands (Oregon)
DTI	Direct Tension Indicator (load indicating washer for bolts)

E

E	East
E&C	Engineering and Contingencies (used in cost estimates)
EA	Expenditure Account
	Environmental Assessment
EAC	Emulsified Asphalt Concrete
EAP	Employee Assistance Program
EB	Eastbound
ECL	East city limits
EDMS	Electronic Data Management System
EEO	Equal Employment Opportunity program
EEO/AA	Equal Employment Opportunity/Affirmative Action
EF	Each face
EIS	Environmental Impact Statement
El.	Elevation
Elev.	Elevation
ELT	Environmental Leadership Team
Emb.	Embankment
EP	Edge of pavement
EPA	Environmental Protection Agency (U.S.)
ES	Edge of shoulder
ESA	Endangered Species Act or Environmental Site Assessment
EVC	End vertical curve
EW	Each way
Exp.	Expansion

F

F	Degrees Fahrenheit
FAPG	Federal Aid Policy Guide (replaced FHPM 12/9/91)
FAS	Federal Aid Secondary (class of highways)
FAT	File Allocation Table (on a computer disk)
FBN	Film base negative
FBPM	Film base positive matte
FEIS	Final Environmental Impact Statement
FEMA	Federal Emergency Management Agency
FF	Far face (don't use for "fill face")
FFO	Full Federal Oversight
FHP	Federal-Aid Highway Program

Bridge Design Manual – June 2020
Oregon Department of Transportation
Section 1 – Design Standards

FHPm	Federal Highway Program Manual (replaced by FAPG)
FHWA	Federal Highway Administration (formerly BPR)
FIPS	Federal Information Processing Standards system (IBM software)
FIS	Flood Insurance Studies (conducted by FHWA)
FONSI	Finding Of No Significant Impact
FRP	Fiber Reinforced Polymer
FS	Far side
ft-k	foot-kips
ft-lbs	foot-pounds
FTA	Federal Transit Administration
FTP	File Transfer Protocol

G

Ga.	Gauge
GAO	General Accounting Office
GDM	Geotechnical Design Manual
GHLT	Geo-Hydro Leadership Team
GIS	Geographic Information System
GLO	Government Land Office
GPR	Ground Penetrating Radar
GPS	Global Positioning System
GR	Guard Rail
GSA	General Services Administration
GSP	Galvanized Steel Pipe
GUI	Graphical User Interface for computers (such as Windows)

H

HBP	Highway Bridge Program (funding)
HBR	Highway Bridge Replacement (type of funding)
HBRR	Highway Bridge Replacement and Rehabilitation (type of funding)
HDD	Hard Disk Drive
HDM	Highway Design Manual
HIP	Highway Improvement Plan (6-year plan of ODOT)
HLT	Highway Leadership Team
HMAC	Hot Mix Asphalt Concrete
HOV	High Occupancy Vehicle
HP&R	Highway Planning & Research program
HPC	High Performance Concrete
HQ	Headquarters
HS	High Strength
HSIS	Highway Safety Information System (FHWA database)
Ht.	Height
HW	High Water
HWM	High Water Mark

I

I/O	Input/Output
I4R	Interstate Resurfacing, Restoration, Rehabilitation and Reconstruction (funding category)
IAMP	Interchange Area Management Plan
IBM	International Business Machines
ID	Inside diameter
IDE	Internal Drive Electronics (type of computer hard disk)
IDT	Idaho Department of Transportation
IF	Inside face (don't use!)
IGA	Inter-Governmental Agreement

Bridge Design Manual – June 2020
Oregon Department of Transportation
Section 1 – Design Standards

IO	Intermodal Oregon
ILT	Intermodal Leadership Team
IS	Information Systems
ISB	Information Systems Branch
ISPF	Integrated System Productivity Facility (IBM mainframe software)
ISTEA	Intermodal Surface Transportation Efficiency Act of 1991
IT	Information Technology
ITIS	Integrated Transportation Information System
ITS	Intelligent Transportation Systems
IWRC	Independent Wire Rope Core (cables)

J

J	Joule, metric energy unit
JCL	Job Control Language (mainframe)
JTA	Oregon Jobs and Transportation Act of 2009

K

k	Kilo, one thousand
K	Kip (kilopound, 1000 pounds)
kg	Kilogram, metric mass unit
km	Kilometer (1000 meters)
kN	KiloNewton, metric force unit
KSF	Kips per Square Foot
KSI	Kips per Square Inch

L

LAN	Local Area Network (computers)
Lbs	Pounds
LC	Length of curve
LCD	Liquid Crystal Display (computers)
LCDC	Land Conservation and Development Commission (Oregon) (now DLCD)
LF	Linear feet
LL	Live load
LMC	Latex Modified Concrete
LOC	League of Oregon Cities
LPA	Local Public Agency
LPT	Line Printer (parallel computer port)
LRFD	Load Resistance Factor Design
<i>LRFD</i>	<i>AASHTO LRFD Bridge Design Specifications</i>
L.S.	Lump Sum
LSDC	Low slump dense concrete
LT	Leadership Team

M

m	Meter, metric length unit
	Milli, one thousandth
M	Mega, one million
MALT	Modes and Area Leadership Team
MAPS-21	Moving Ahead for Progress in the 21 st Century (funding)
MBM,MFBM	Thousand feet board measure
MC	Microsilica modified concrete
MCTD	Motor Carrier Transportation Division
MH	Manhole
MHz	MegaHertz (millions of cycles per second)
MLT	Maintenance Leadership Team
MP	Microfilm print

Bridge Design Manual – June 2020
Oregon Department of Transportation
Section 1 – Design Standards

	Milepoint, milepost (even milepoint)
MPO	Metropolitan Planning Organization
MOA	Memorandum of Agreement
MOU	Memorandum Of Understanding
MSC	Minor structure concrete
MSCS	Management Scheduling Control System (to replace PCS)
MS-DOS	Microsoft Disk Operating System
MSDS	Material Safety Data Sheet
MSE	Mechanically Stabilized Earth (retaining walls)
MSL	Mean Sea Level
MTPA	Major Transportation Projects Agreement

N

N	North
	Newton, metric force unit
NACE	National Association of Corrosion Engineers
NAVD 88	North American Vertical Datum 1988
NB	Northbound
NBI	National Bridge Inventory
NBIS	National Bridge Inspection Standards
NCEER	National Center for Earthquake Engineering Research (Buffalo, NY)
NCHRP	National Cooperative Highway Research Program (from the Transportation Research Board)
NCL	North city limits
NEPA	National Environmental Protection Act of 1969
NF	Near face
NGVD	National Geodetic Vertical Datum (MSL = 0.0)
NHI	National Highway Institute
NHPP	National Highway Performance Program
NHS	National Highway System
NHTSA	National Highway Traffic Safety Administration
NICET	National Institute for Certification in Engineering Technologies
NMFS	National Marine Fisheries Service
NOAA	National Oceanic & Atmospheric Administration (U.S. Dept. of Commerce)
NSM	Near Surface Mount
NSPE	National Society of Professional Engineers
NT	New Technology (new version of Microsoft Windows)
NTS	Not to Scale

O

OAR	Oregon Administrative Rule
OBIS	Oregon Bridge Inventory System
OC	On Center (center-to-center)
OCAPA	Oregon Concrete & Aggregate Producers Association, Inc.
OD	Outside Diameter
ODF&W	Oregon Department of Fish and Wildlife
ODOT	Oregon Department of Transportation
OERS	Oregon Emergency Response System
OG	Original Ground
OHP	Oregon Highway Plan
OIT	Oregon Institute of Technology
OMUTCD	Oregon Manual on Uniform Traffic Control Devices
OO, O-O	Out-to-out
OPEU	Oregon Public Employees Union
OPL	Office of Project Letting
OPO	ODOT Procurement Office

Bridge Design Manual – June 2020
Oregon Department of Transportation
Section 1 – Design Standards

Ops.	Operations
ORS	Oregon Revised Statutes
OS	Operating System
OSHA	Occupational Safety and Health Administration (U.S.)
OSHD	Oregon State Highway Division
OSP	Oregon State Police
	Oregon State Parks
OSU	Oregon State University
OTC	Oregon Transportation Commission
OTIA	Oregon Transportation Investment Act (I, II, & III)
OTP	Oregon Transportation Plan
Oxing	Overcrossing
OZ	Ozolid print

P

Pa	Pascal, metric stress or pressure unit
PA	Price Agreement
PBLT	Planning Business Line Leadership Team
PC	Personal computer
	Point of curvature
P/C	Precast Concrete
PCA	Portland Cement Association
PCC	Portland Cement Concrete
	Point on compound curve
PCF	Pounds per Cubic Foot
PCI	Prestressed Concrete Institute
PCP	Prestressed concrete pipe
PCS	Project Control System (to be replaced by MSCS)
	Point of change from circular curve to spiral
PDG	Project Delivery Guide
PDLT	Project Delivery Leadership Team
PE	Professional Engineer (registered)
	Preliminary engineering
PEBB	Public Employees Benefit Board
PERS	Public Employees Retirement System
PI	Point of intersection
	Public Information
PL	Project Leader
	Performance Level of bridge rail
PM	Project Manager
PMC	Polymer-modified concrete
PMS	Pavement Management System
PMT	Photo transfer paper
PO	Purchase Order
POC	Point on circular curve
POR	Professional of Record
POS	Point on spiral
POT	Point on tangent
PQR	Pre-Qualification Request
PR	Project Request (Federal-Aid Program)
	Public Relations
Prest.	Prestressed
PRC	Point of reverse curve
PRN	Printer port (parallel port on computer, =LPT)
PS	Point of change from tangent to spiral
P/S	Prestressed Concrete

Bridge Design Manual – June 2020
Oregon Department of Transportation
Section 1 – Design Standards

PS&E	Plans, Specifications & Estimate
PSBS	Project Specifications Bid System
PSC	Point of change from spiral to circular curve
PSF	Pounds per Square Foot
PSI	Pounds per Square Inch
PSK	Personal Services Contract
PSU	Portland State University
PT	Point of tangency
P/T	Post-tensioned concrete
PTI	Post-Tensioning Institute
PUC	Public Utility Commission
PVC	Point on vertical curve
	Polyvinyl chloride
PVI	Point of vertical intersection
PWRR	Portland Western Railroad

Q

QA	Quality Assurance
QC	Quality Control
QCT	Quality Control Technician
QPL	Qualified Products Listing

R

R	Radius
R, 1R	Resurfacing
R.	Range (surveying)
R/D	Rough Draft
R/W	Right of Way
R&D	Research and Development
RAM	Random Access Memory
RBI	Region Bridge Inspector
RC	Reinforced Concrete
RCB	Reinforced Concrete Box
RCBC	Reinforced Concrete Box Culvert
RCBG	Reinforced Concrete Box Girder
RCDG	Reinforced Concrete Deck Girder
RCP	Reinforced Concrete Pipe
Rdwy.	Roadway
REA	Revised Environmental Assessment
Rev.	Revised; revision date
RFI	Request for Information
RFP	Request for Proposals
RFQ	Request for Qualifications
RLT	Roadway Leadership Team
RMS	Root Mean Square (statistical average)
ROD	Record of Decision
ROM	Read-Only Memory
RR	Railroad
RRR, 3R	Resurfacing, Restoration and Rehabilitation
RRRR, 4R	Resurfacing, Restoration, Rehabilitation and Reconstruction
RSA	Response Spectrum Analysis

S

S	South
S.	Section (surveying)
SAFETEA-LU	Safe, Accountable, Flexible, Efficient Transportation Equity Act: A Legacy of Users of

Bridge Design Manual – June 2020
Oregon Department of Transportation
Section 1 – Design Standards

	2005
SB	Southbound
SC	Structural Concrete
SCL	South city limits
SCSI	Small Computer Systems Interface (type of computer hard disk)
SEAO	Structural Engineers Association of Oregon
SEAOC	Structural Engineers Association of California
Sec.	Section (map location)
Sect.	Section (on a drawing)
SF	Square feet
SFC	Silica Fume Concrete
SFLMC	Silica Fume Latex-Modified Concrete
SH, Shld	Shoulder
SHPO	State Historic Preservation Office
SHRP	Strategic Highway Research Program
SI	"Système Internationale" (International System of units)
SI&A	Structure Inventory and Appraisal
SIBC	Slide In Bridge Construction
SIMM	Single In-line Memory Module (type of memory chips)
SLT	Safety Leadership Team
SOQ	Statement of Qualifications
SOW	Statement of Work
SP	<i>ODOT Construction Specifications</i>
SPC	Seismic Performance Category
SPFPC	System Productivity Facility for Personal Computers (data file editing software)
SPIS	Safety Priority Index System
SPRR	Southern Pacific Railroad
SPT	Standard Penetration Test for soils
SR	Sufficiency Rating
SRCM	Soils and Rock Classification Manual (ODOT)
SRSS	Square Root of the Sum of the Squares (method of combining seismic forces or displacements)
SSDM	Strategic Systems & Data Management (a unit within Technical Services)
SSPC	Structural Steel Painting Council
STE	Supervising Transportation Engineer
STP	Single Trip Permit
	Surface Transportation Program
S.T.R.	Section, Township and Range (surveying)
STRAHNET	Strategic Highway Corridor Network
STIP	State Transportation Improvement Program
STRUDL	Structural Design Language
SW	Sidewalk
SY	Square Yard

T

T.	Township (surveying)
	Tangent
T&E	Threatened and Endangered
Tan.	Tangent
TAC	Technical Advisory Committee
TAG	Technical Advisory Group
TB	Test boring
TCP	Traffic Control Plan
TEAMS	Transportation Environment Accounting System
TF	Top Face
TFE	Polytetrafluoroethylene (sliding surface for bearings)

Bridge Design Manual – June 2020
Oregon Department of Transportation
Section 1 – Design Standards

TH	Test hole
Thk	Thick, thickness
TIFIA	Transportation Infrastructure Finance and Innovation Act (FHWA)
TIP	Transportation Improvement Plan
TLC	Technical Leadership Center
TLT	Technical Leadership Team
TMOC	Transportation Management Operations Center
TMP	Traffic Management Plan
TP&DT	Temporary Protection and Direction of Traffic
TRB	Transportation Research Board
TS	Tube, Structural
TS&L	Type, Size and Location (formerly called preliminary)
TSF	Tons per Square Foot (don't use)
TSO	Time Sharing Option (on mainframe computer)
TTS	Tracings To Specifications
Typ.	Typical

U

UBC	Uniform Building Code
UFAS	Uniform Federal Accessibility Standards
U of O	University of Oregon
UHPC	Ultra High Performance Concrete
UP	University of Portland
UPRR	Union Pacific Railroad
URLT	Utility Relocation Leadership Team
USACE, ACOE	U.S. Army Corps of Engineers
USC&GC	United States Coast and Geodetic Survey
USCG	United States Coast Guard
USFS	U.S. Forest Service (Dept. of Agriculture)
USFWS	U.S. Fish and Wildlife Service
USGS	United States Geological Survey
USRS	U.S. Reclamation Service
Uxing	Undercrossing

V

V.	Version (software)
Var.	Varies
VC	Vertical curve
VE	Value Engineering
VGA	Video Graphical Array (computers)
VM	Vicinity Map
VMT	Vehicle miles of travel

W

W	West
W/	With
W/O	Without
WAN	Wide Area Network (computers)
WATS	Wide Area Telephone Service
WB	Westbound
WCL	West city limits
WCLIB	West Coast Lumber Inspection Bureau
W.M.	Willamette Meridian
WOC	Work Order Contract
WPS	Welding Procedure Specifications
WS	Wearing surface

Bridge Design Manual – June 2020
Oregon Department of Transportation
Section 1 – Design Standards

WSDOT	Washington State Department of Transportation
WSC	Wire Strand Core (cables)
Wt.	Weight
WWF	Welded Wire Fabric
WWM	Welded Wire Mesh
WWPA	Western Wood Products Association
WYSIWYG	What-you-see-is-what-you-get (computer interface)

X

X'Sect	Cross-section
XF	Xerox film
Xing	Crossing
XV	Xerox vellum

Y

Z

APPENDIX – SECTION 1.2 – AASHTO/BDM CROSS-REFERENCE

Bridge Design Manual		AASHTO LRFD Cross-References		
BDM Section	Title	LRFD Section	Title	Comments
3.14.7.2 3.18.3	Bridge Length	2.6.4.3	Bridge Waterway	BDM adds specific design floods and minimum freeboard to AASHTO specs.
3.18.2(2)	Structure Depth	2.5.2.6.3-1	Span to Depth Ratios	BDM gives span-to-depth ratios for concrete bridges but leaves span-to-depth ratios for steel bridges to AASHTO.
3.18.2(2)	Structure Depth	2.5.2.6.2	Criteria For Deflection	BDM states that AASHTO optional live load deflection criteria is not required for bridges that satisfy the span-to-depth ratios in BDM 2.5.2.6.3-1 3.18.2(4)
3.17.1(1)	Bridge Types and Economics	4.6.2.1.4, 5.14.4.1, 9.7.1.4	Slab Edge Beam Requirements	BDM Yields to AASHTO Requirements. AASHTO requirements also apply to CIP voided slabs if design deviation is approved.
3.14.7.1	Hydraulics, General	2.6.4.4.2	Bridge Scour	BDM states that bottom of spread footings should be 6 feet below normal streambed. AASHTO states that the bottom of footing should be below the scour depth.
1.10.5.3	Spread Footing Foundation Design	10.6.1.2	Bearing Depth	BDM states that spread footings should be at least 6 feet below streambed and also below the scour depth for the 500-year flood event. AASHTO states that the footings should be located to bear below the maximum anticipated depth of scour.
1.10.5.3(2)	Nominal and Factored Bearing Resistances	10.5.5.2.2	Spread Footings	BDM resistance factors for bearing of spread footings are higher than those shown in Table 10.5.5.2.2 in the AASHTO Specs for extreme event conditions of scour and earthquake loading.

Bridge Design Manual – June 2020
Oregon Department of Transportation
Section 1 – Design Standards

1.10.5.3(4)	Spread Footing Stability	11.6.2.3	Overall Stability	BDM specifies a factor of safety 1.5 for overall stability. AASHTO specifies phi factors for stability = 0.75 or 0.65 depending on geotechnical information.
1.10.5.4(1)	Pile Resistance	10.7.3.8	Nominal Axial Pile Resistance	BDM refers specifically to AASHTO specs for determining axial pile capacity.
1.10.5.5(1)	Drilled Shaft Diameters and Requirements	10.8.1.3	Shaft Diameter	BDM states that smallest shaft diameter is 12 inches. AASHTO adds that if the shaft is to be manually inspected, the diameter should not be less than 30 inches.
1.10.5.5(1)	Column Diameter	10.8.1.3	Maximum Column Size	AASHTO states that columns on top of drilled shafts can be the same size as the drilled shaft, but BDM requires that columns be smaller than shafts by 6 inch or 1 foot depending on shaft diameter.
1.10.5.5(7)	Shaft Settlement	10.8.2.2	Shaft Settlement	BDM refers to AASHTO for the determination of drilled shaft settlement.
1.10.5.5(12)	Shaft Reinforcement	5.13.4.6.3	Volumetric Reinforcement Ratio and transverse rebar spacing	BDM overrides LRFD 5.13.4.6.3 because the shaft diameter is always larger than the column diameter.
1.10.5.5(12)	Shaft Reinforcement	5.13.4.6.3	Volumetric Reinforcement Ratio and transverse rebar spacing	BDM adds a formula for computing transverse reinforcement required in non-contact splice region.
1.10.5.5(14)	Shaft Reinforcement Cover	5.12.3-1	Cover for Main Reinforcing Steel	BDM provides specific reinforcement cover requirements for drilled shafts.
1.3.1(4)	Load From Wearing Surface	3.5.1-1	Unit Weights	BDM assumes 150 pcf for ACWS, but AASHTO assumes 140 pcf.
1.3.2(2)	Pedestrian Structures	3.6.1.6	Pedestrian Loads	Both BDM and AASHTO specify 85 psf

Bridge Design Manual – June 2020
Oregon Department of Transportation
Section 1 – Design Standards

1.3.6	Thermal Forces	3.12.2.1-1	Temperature Ranges	Temperature ranges vary slightly between BDM and AASHTO for Moderate and Rigorous Climates
1.4.1	Ductility, Redundancy, and Operational Importance	1.3.3, 1.3.4, 1.3.5	Ductility, Redundancy, and Operational Importance	BDM requires State Bridge Engineer approval for Redundancy Factor less than 1.0, and it states that for the Operational Importance Factor, use a value of 1.0 for all bridges, assuming all bridges to be "typical".
1.3.3	Sidewalk Loading	3.6.1.6	Pedestrian Loads	BDM adds specific details for applying vehicular live load to curb mountable sidewalks.
1.4.2	Shear Correction Factor for Skewed Girders	4.6.2.2.3c	Skewed Bridges	BDM includes additional design criteria for the application of the skew correction factor for computing shear in skewed beams.
1.11.2.3	Wingwall Design and Construction	11.6.1.5.2	Wingwalls	BDM adds bar extension requirements for abutments on stiff footings to distribute flexure. AASHTO does state that bar lengths should vary to avoid "planes of weakness"
1.17	Seismic Design	3.10, 5.10.11, 5.13.4.6, 11.6.5, 11.8.6, 11.10.7	Earthquake Effects	BDM specifies the use of AASHTO Guide Specifications for LRFD Seismic Bridge Design for projects initiated after May 1st 2009. For projects initiated before May 1st 2010, BDM specifies the use of AASHTO LRFD Bridge Design Specifications. Additional requirements and guidelines for both AASHTO documents are included in the BDM.
1.5.1	Concrete, General	5.4.2.1	Compressive Strength	BDM has independent concrete classes.
1.5.1	Concrete, General	5.4.2.4	Modulus of Elasticity	BDM and AASHTO have same formula
1.5.5.1.2	Minimum Bar Covering	5.12.3	Concrete Cover	BDM and AASHTO have separate tables
1.5.5.1.3	Reinforcement for Shrinkage and Temperature	5.10.8	Shrinkage and Temperature Reinforcement	BDM bases reinforcement area on concrete thickness only, but AASHTO bases reinforcement area on ratio of volume of section

Bridge Design Manual – June 2020
Oregon Department of Transportation
Section 1 – Design Standards

				to perimeter of section. AASHTO also has additional required minimum spacing for specific elements.
1.5.5.1.6	Minimum Bar Spacing	5.10.3	Spacing of Reinforcement	BDM specifies 2.5d for the bar spacing, but AASHTO specifies 1.5d for clear distance between bars. Both state 1.5 inches minimum clear between bars and 1.5(maximum aggregate size) for minimum clear between bars.
1.5.5.1.8	Compression Development Length	5.11.2.2.1	Compression Development Length	AASHTO gives two equations with the one that results in the lowest value controlling. BDM specifies the largest value from the equations.
1.5.6.1	Precast Prestressed Elements	5.9.4.1.2-1, 5.9.4.2.2-1	Tensile Stress Limits	AASHTO allows $0.19\sqrt{f'c}$ for certain situations but BDM allows only $0.0948\sqrt{f'c}$
1.5.8.8	Post-Tension Strand Duct Placement	5.10.3.3.2	Post-Tensioning Ducts C-C Spacing	AASHTO specifies spacing requirements; BDM doesn't call out spacing requirements.
1.14.1.2	Elastomeric Bearing Pads	14.7.5, 14.7.6	Elastomeric Pads and Steel Reinforced Elastomeric Pads	BDM specifies that AASHTO Method A should be used to design bearing pads unless there is a specific need to use AASHTO Method B.
1.14.1.3	Proprietary Pot, Disc, Slide, Radial, or Spherical Bearings	5.4.2.3	Shrinkage and Creep	BDM provides a simplified approach for determining creep and shrinkage coefficients.
1.9.1	Deck Design and Detailing	9.7.2	Empirical Design of Decks	BDM excludes the use of the Empirical Method in AASHTO for deck design
1.9.1	Deck Design and Detailing	4.6.2.1	Decks	BDM deck design tables utilize AASHTO specifications from LRFD 4.6.2.1 to develop reinforcement values.
1.14.2	Deck Expansion Joint Seals	14.5.6.6	Compression and Cellular Seals	AASHTO specifies a maximum skew angle for compression joint seals equal to 20 degrees, but this limitation is not stated in the BDM

Bridge Design Manual – June 2020
Oregon Department of Transportation
Section 1 – Design Standards

				or Standard Drawing.
1.13.1.1	Rail Selection	13.7.2	Test Level Selection Criteria	AASHTO Defines Test Level Criteria
1.13.1.1	Rail Selection	A13.2	Traffic Rail Design Forces	AASHTO provides design forces in rails in Table A13.2-1
1.6.1	Steel Girders	C6.13.6.1.4a	Flexural Members	BDM modifies this AASHTO comment to reflect moment of inertia of the smaller section rather than the smaller flange.
1.4.1	(Timber) Preservative Treatment	8.4.3.2	(Wood) Treatment Chemicals	AASHTO has specific requirements for the use of wood preservative chemicals on pedestrian bridges.
1.15.1	Soundwalls, General	1-2.1.2 (AASHTO Guide Specs for Sound Barriers)	Wind Load	AASHTO Guide Specs for Sound Barriers provides wind load equations and exposure categories. Example designs are also provided
1.15.2	Soundwall Seismic Load	1-2.1.3 (AASHTO Guide Specs for Sound Barriers)	Seismic Load	AASHTO Guide Specs for Sound Barriers provides equations and factors for seismic loads on sound barriers.
1.15.3	Soundwall Overturning Factor of Safety	1-8.2 (AASHTO Guide Specs for Sound Barriers)	Spread Footings	BDM uses AASHTO factors of safety with slight modifications. (Ice and snow load not included)
3.14.4.2	Roadway Clearances	2.3.3.3	Highway Horizontal Clearances	AASHTO calls out horizontal clearance requirements that are consistent with the values shown in BDM Figure 3.14.4.2A-B
1.38.4	Falsework	Figure 16 (AASHTO Construction Handbook for Bridge Temporary Works)	Bridge Deck Falsework	See AASHTO Figure 16 for conceptual layout of deck overhang falsework.
1.38.6.2	Cofferdams and Seals	Page 71 (AASHTO Construction)	Sealing and Buoyancy Control	AASHTO confirms that force from sheet pile friction should not be included in uplift resistance.

Bridge Design Manual – June 2020
Oregon Department of Transportation
Section 1 – Design Standards

		Handbook for Bridge Temporary Works)		
1.3.4	ODOT Design Instructions for AASHTO LRFD Bridge Design Specifications	3.6.5	Vehicular Collision Force	BDM adds specific requirements for barriers in front of obstacle components.
1.3.5	ODOT Design Instructions for AASHTO LRFD Bridge Design Specifications	2.6.4, 3.7.5	Hydraulic Analysis	BDM modifies AASHTO specs regarding scour depth and degradation and Extreme Limit States

APPENDIX – SECTION 1.11 – SUBSTRUCTURES

A1.11.1.7 End Bent Details for Prestressed Slabs and Boxes

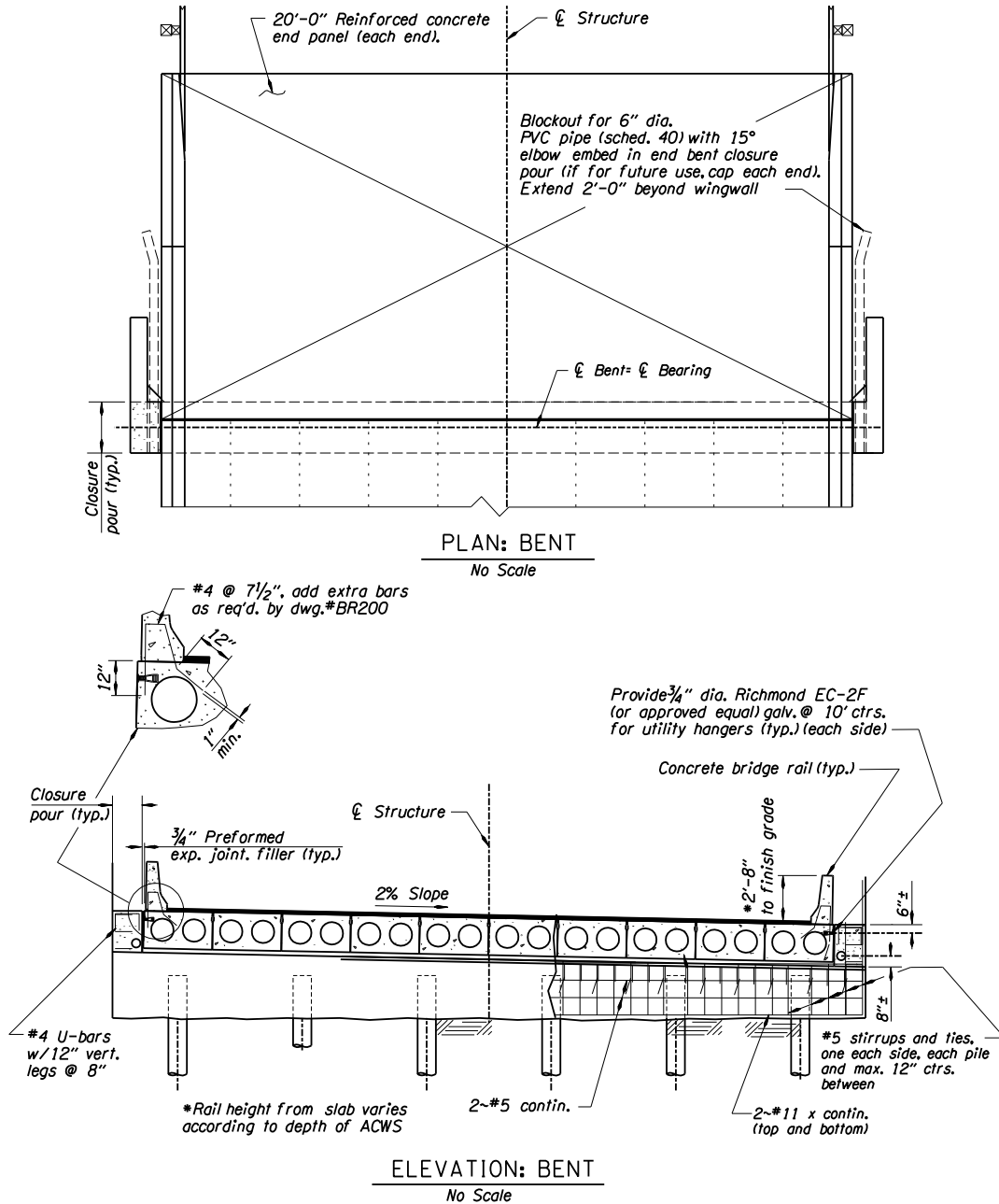

Figure A1.11.1.7A

Bridge Design Manual – June 2020
Oregon Department of Transportation
Section 1 – Design Standards

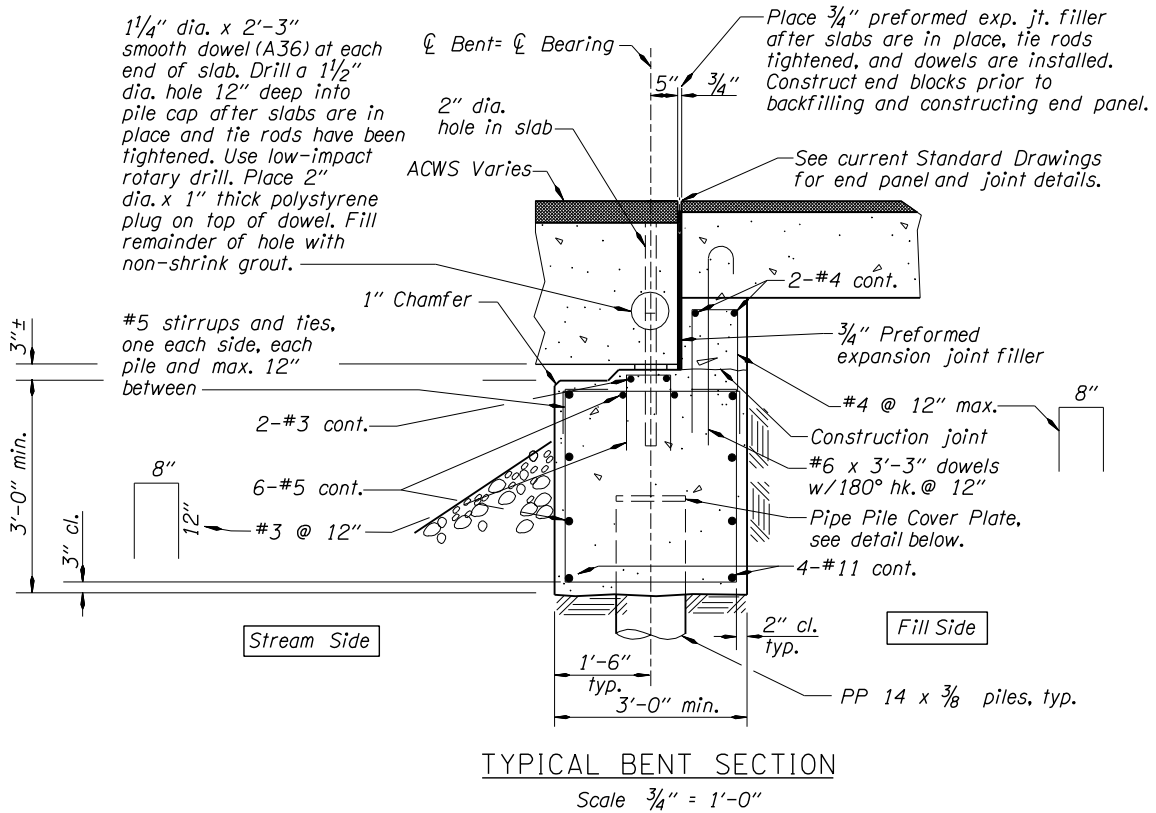

Figure A1.11.1.7B

Bridge Design Manual – June 2020
 Oregon Department of Transportation
 Section 1 – Design Standards

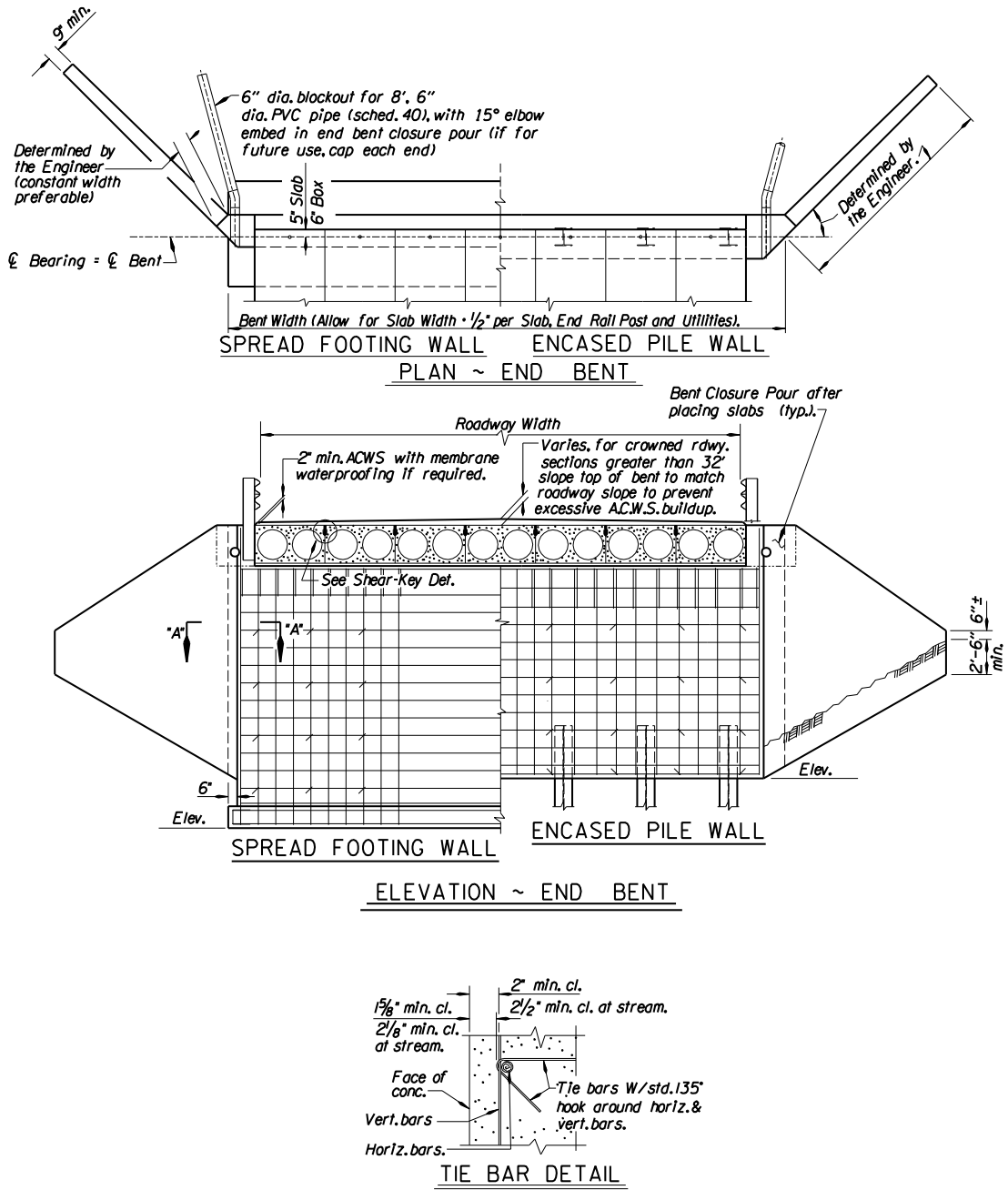
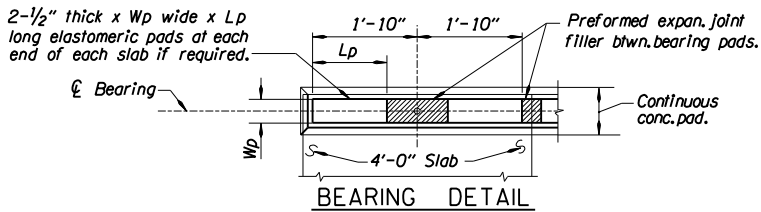
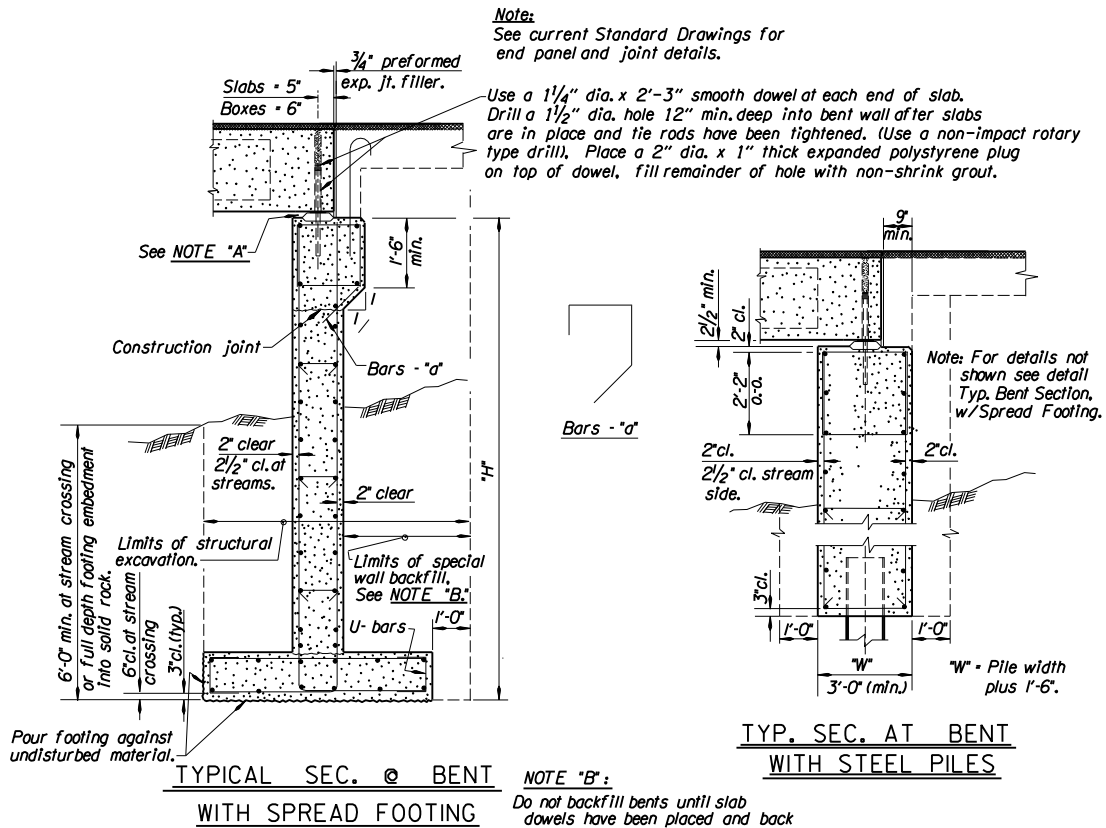
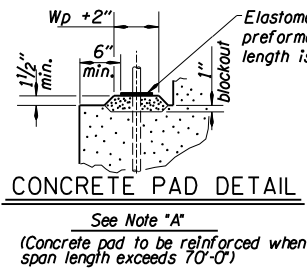

Figure A1.11.1.7C

Bridge Design Manual – June 2020
Oregon Department of Transportation
Section 1 – Design Standards



Slab Depth	Wp	Lp
15"	5"	16"
18"	5"	18"
21"	5"	20"
26"	5 1/2"	20"
30"	6"	20"



NOTE "A":
Pour 2" concrete pad. Place 1/2" concrete layer a min. of 3 days after pad is poured. Place elastomeric bearing pads and prestressed slabs before 1/2" concrete is fully set to insure uniform bearing across full width of slab. If uniform bearing is not achieved, lift slab and repeat procedure. Any excess concrete protruding above bottom of bearing pads shall be removed immediately after placing slab.

Figure A1.11.1.7D

Bridge Design Manual – June 2020
 Oregon Department of Transportation
 Section 1 – Design Standards

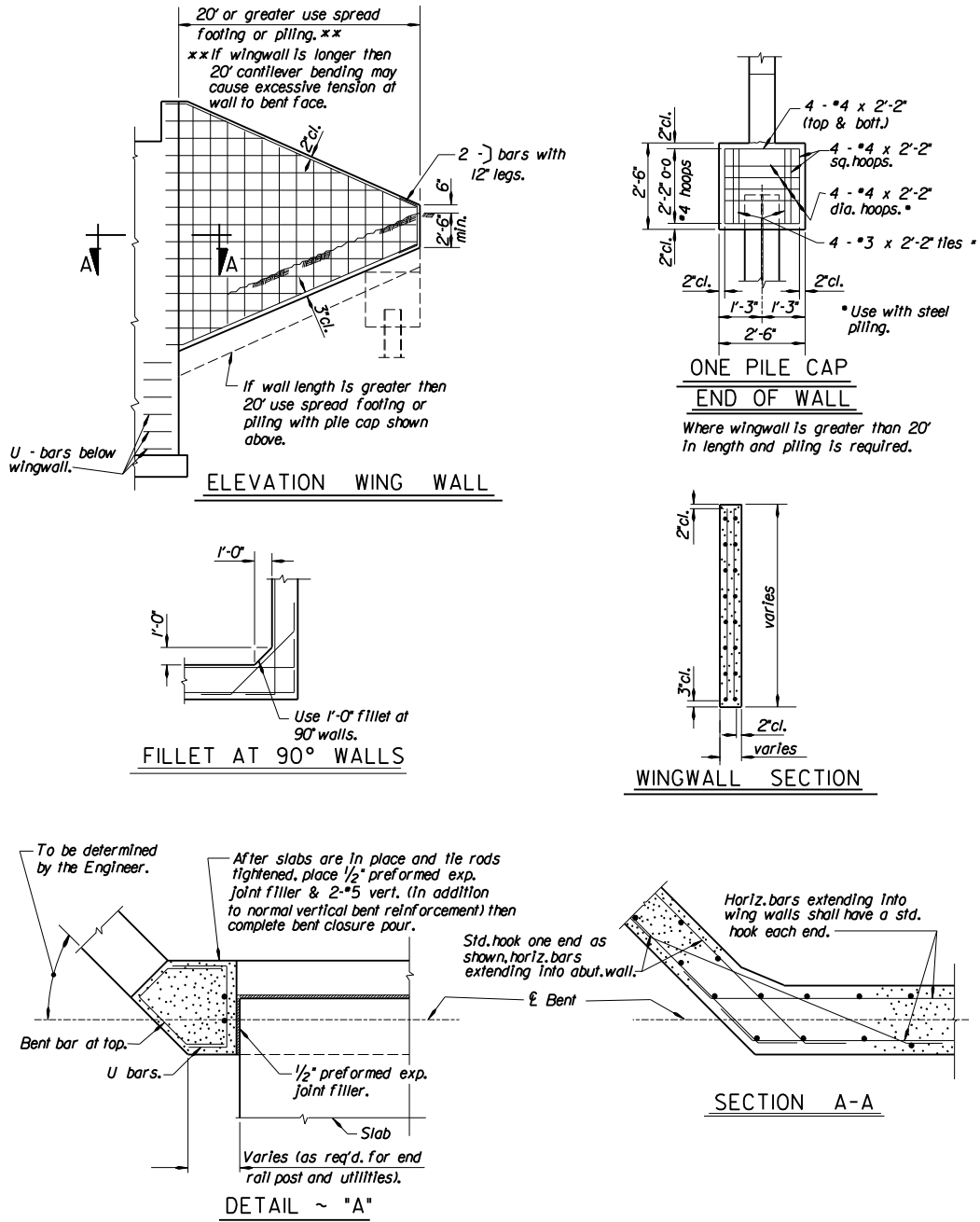

Figure A1.11.1.7E

A1.11.2.2 Interior Bent Details for Prestressed Slabs and Boxes

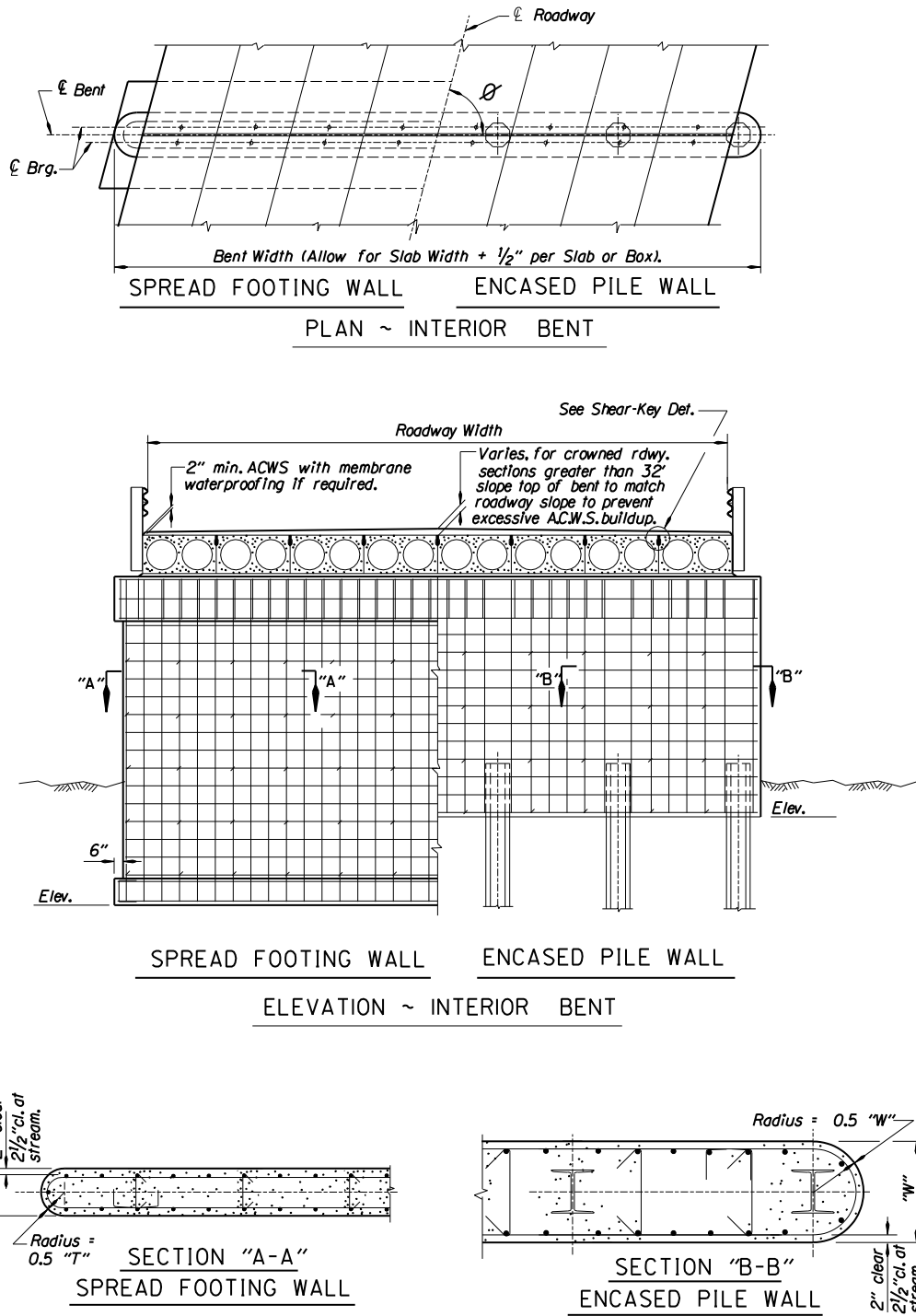

Figure A1.11.2.2A

Bridge Design Manual – June 2020
 Oregon Department of Transportation
 Section 1 – Design Standards

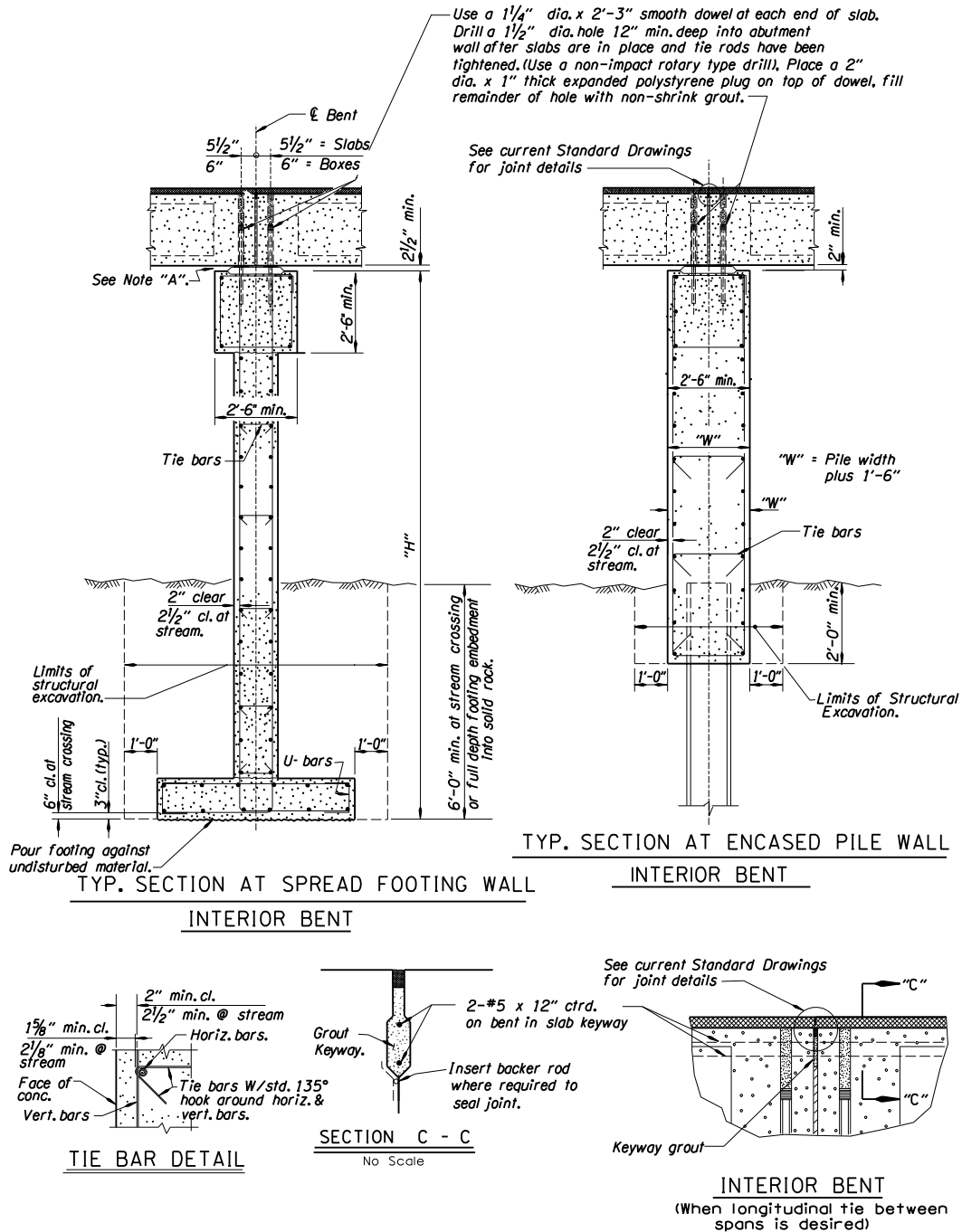
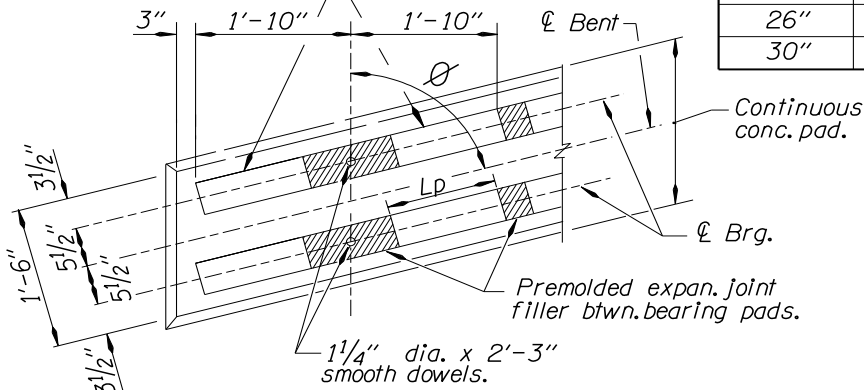

Figure A1.11.2.2B

Bridge Design Manual – June 2020
Oregon Department of Transportation
Section 1 – Design Standards

2-1/2" thick x Wp wide x Lp long elastomeric pads at each end of each slab if required.



Slab Depth	Wp	Lp
15"	5"	16"
18"	5"	18"
21"	5"	20"
26"	5 1/2"	20"
30"	6"	20"

BEARING DETAIL
(PRESTRESSED SLABS)

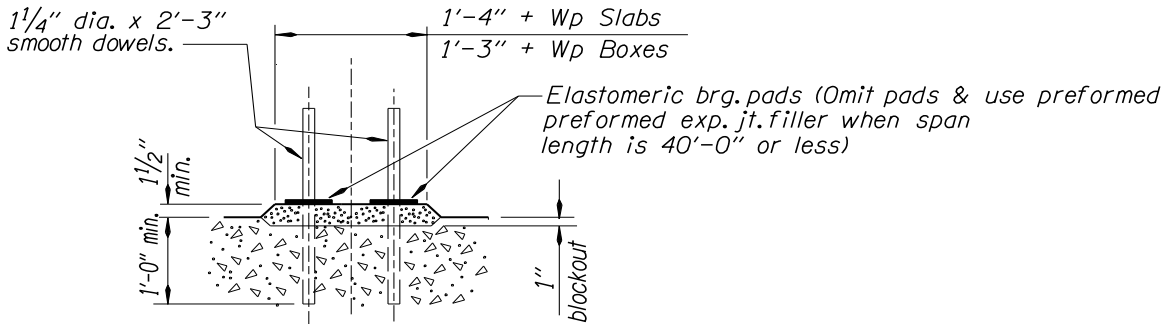

CONCRETE PAD DETAIL

See Note "A" below

(Concrete pad to be reinforced when length exceeds 70')

NOTE "A" :

Pour 2" concrete pad. Place 1/2" concrete layer a min. of 3 days after pad is poured. Place elastomeric bearing pads and prestressed slabs before 1/2" concrete is fully set to insure uniform bearing across full width of slab. If uniform bearing is not achieved, lift slab and repeat procedure. Remove any excess concrete protruding above bottom of bearing pads immediately after placing slab.

Figure A1.11.2C

APPENDIX – SECTION 1.20.2.2 – RESIN ANCHOR DESIGN

This appendix contains the legacy equations used by designers prior to 2019, which were replaced by the equations according to ACI 318 Chapter 17 with ODOT modifications. Use the legacy equations only when it is required.

General Equation for Resin Tension Capacity

Ultimate tension capacity = $R_0 \cdot R_1 \cdot R_2 \cdot \pi \cdot D \cdot E \cdot [U(\max) - (35 \text{ lb/in}^3 \cdot E)]$
where:

$$\pi = \text{Pi} = 3.14159$$

D = anchor diameter (inches)

E = anchor embedment (inches)

U(max) = 1400 psi for “low strength” resin
= 2300 psi for “high strength” resin

R_0 = reduction factor for non-redundant applications. This applies when anchors are used with only two anchors per attachment.

$R_0 = 0.85$ for non-redundant horizontal applications

$R_0 = 1.0$ for all other applications

R_1 = reduction factor due to edge distance

$R_1 = 1.0 - (1.5 - A)/2.5$ when edge distance $< 1.5 \cdot E$

$R_1 = 1.0$ when edge distance $\geq 1.5 \cdot E$

where A = edge distance/E

R_2 = reduction factor due to anchor spacing

$R_2 = 1.0 - (1.0 - B)/1.7$ when anchor spacing $< 1.0 \cdot E$

$R_2 = 1.0$ when anchor spacing $\geq 1.0 \cdot E$

where B = anchor spacing/E

Specify edge distance and anchor spacing greater than $6 \cdot D$ or $0.5 \cdot E$, whichever is greater.

When rebar is anchor material, add 2 times the anchor diameter to the required anchor embedment. This extra embedment is necessary for rebar since the exact location of rebar deformations cannot be known. Most of the tension load in a rebar anchor is transferred to the concrete at the deformation location. For this reason fully-threaded anchors are generally preferred for most resin-bonded anchor applications.

For horizontal applications, add 20 percent to the required anchor embedment. This extra embedment is necessary since full resin coverage cannot be assured for horizontal applications. Horizontal applications angled down a minimum of 15 degrees do not require the additional 20 percent.

Resin Tension Equation: Service Loads

Ultimate tension capacity $\geq 3 \cdot$ design tension load

Resin Tension Equation: Seismic Loads

Ultimate tension capacity:

$\geq 1.9 \cdot$ design seismic load for “low strength” resin

$\geq 1.6 \cdot$ design seismic load for “high strength” resin

Note: for seismic loading, maximum rod loading $\leq 0.9 F_y$
 F_y = Yield strength of the anchor rod

Resin Tension Equation: LRFD Loads

$0.5 * \text{Ultimate tension capacity} \geq \text{factored load}$

General Equation for Resin Shear Capacity

Ultimate Shear Capacity = $R_1 * R_2 * \lambda * D * E * f_c$

where:

D = anchor diameter (inches)

E = anchor embedment (inches)

f_c = compressive strength of concrete

λ = 0.75 for “low strength” resin

= 1.0 for “high strength” resin

R_1 = reduction factor due to edge distance

$R_1 = 1.0 - (1.5-A)/2.0$ when edge distance $< 1.5 * E$

$R_1 = 1.0$ when edge distance $\geq 1.5 * E$

R_2 = reduction factor due to anchor spacing

$R_2 = 1.0 - (1.0-B)/1.7$ when anchor spacing $< 1.0 * E$

$R_2 = 1.0$ when anchor spacing $\geq 1.0 * E$

If concrete for an existing structure appears to be in good condition, use $f_c = 1.2$ times the concrete strength shown on the existing plans.

Resin Shear Equation: Service Loads

Ultimate shear capacity $\geq 3 * \text{design shear load}$

Resin Shear Equation: Seismic Loads

Ultimate shear capacity $\geq 1.7 * \text{design seismic shear load}$

Resin Shear Equation: LRFD Loads

$0.5 * \text{Ultimate shear capacity} \geq \text{factored load}$

Combined Resin Tension and Shear

Combined Stress Ratio (CSR) ≤ 1.0

$$\text{CSR} = (f_t / F_t) + (f_v / F_v)^2$$

f_t, f_v = factored loads (i.e., the right side of service load, seismic, or LRFD equations)

F_t, F_v = capacities (i.e., the left side of service load, seismic, or LRFD equations)

VERSION JUNE 2020

6/1/2020



BRIDGE DESIGN MANUAL

SECTION 2: DESIGN GUIDANCE

BRIDGE ENGINEERING SECTION

OREGON DEPARTMENT OF TRANSPORTATION

Table of Contents

2.1	Section 2 – Introduction	2
2.2	ACCELERATED BRIDGE CONSTRUCTION (ABC) GUIDELINES	3
2.2.1	Introduction.....	3
2.2.2	ODOT encourages and supports ABC Projects.....	4
2.2.3	Contracting Methods Allowed.....	4
2.2.4	Decision Making Framework.....	5
2.2.5	ABC – Decision and Economic Modeling Analysis Tool using the Analytic Hierarchy Process (AHP)	8
2.2.6	Steel Structures.....	12
2.2.7	Concrete Structures.....	12
2.2.8	Full Depth Deck Panels, End Panels or Approaches and Wingwalls.....	12
2.2.9	Precast Connections in Seismic Regions.....	13
2.2.10	Use of Self-Propelled Modular Transporters (SPMT).....	16
2.2.11	Geotechnical Considerations.....	16
2.2.12	Accelerated Embankment Construction.....	18
2.2.13	QA/QC, Quality Control for Prefabricated Concrete Elements.....	19
2.2.14	Cost Considerations.....	21
2.2.15	Listing of bridges replaced using ABC techniques.....	23
2.3	STRUCTURE APPEARANCE AND AESTHETICS	24
2.3.1	General.....	24
2.3.2	Location and Surroundings.....	25
2.3.3	Horizontal and Vertical Geometry.....	25
2.3.4	Superstructure Type and Shape.....	26
2.3.5	Bent Shape and Placement.....	26
2.3.6	End Bent Shape and Placement.....	26
2.3.7	Parapet and Railing Details.....	27
2.3.8	Colors.....	27
2.3.9	Textures.....	27
2.3.10	Ornamentation.....	28
2.4	Bridge Types & Selection Guidance	29
2.4.1	Bridge Types and Economics.....	29
2.4.2	Substructure Guidance.....	31
2.4.3	Special Considerations for Federal-Aid Projects.....	31
2.4.4	Use of Salvage Materials.....	33
2.5	Bridge Layout	34
2.5.1	Site Constraints.....	34
2.5.2	Spans and Proportions.....	34
2.5.3	Bridge Length.....	36
2.5.4	Substructure Guidance.....	36
2.6	Safety and Accessibility Requirements	37
2.6.1	Uniform Accessibility Standards.....	37
2.6.2	Inspection and Maintenance Accessibility.....	38
2.7	Bridge Security Design Considerations	40
2.7.1	Bridge Security Design Considerations.....	40
2.7.2	Placing Buildings Beneath ODOT Bridges.....	42
2.8	Bridge Name Plates & Markers	44
2.8.1	Existing Bridge Name Plates.....	44
2.8.2	Bridge ID Markers.....	44

Note: Revisions for June 2020 are marked with yellow highlight. Deleted text is not marked; past editions of the BDM are available for comparison.

2.1 SECTION 2 – INTRODUCTION

BDM Section 2 for design guidance pertinent to highway bridges and structures design.

See *BDM Section 1* for standards and practices pertinent to design of highway bridges and structures.

See *BDM Section 3* for standards and practices pertinent to design procedures and quality processes for completing highway bridge and structure design.

2.2 ACCELERATED BRIDGE CONSTRUCTION (ABC) GUIDELINES

[2.2.1 Introduction](#)

[2.2.2 ODOT encourages and supports ABC Projects](#)

[2.2.3 Contracting Methods Allowed](#)

[2.2.4 Decision Making Framework](#)

[2.2.5 ABC – Decision and Economic Modeling Analysis Tool using the Analytic Hierarchy Process \(AHP\)](#)

[2.2.6 Steel Structures](#)

[2.2.7 Concrete Structures](#)

[2.2.8 Full Depth Deck Panels, End Panels or Approaches and Wingwalls](#)

[2.2.9 Precast Connections in Seismic Regions](#)

[2.2.10 Use of Self-Propelled Modular Transporters \(SPMT\)](#)

[2.2.11 Geotechnical Consideration](#)

[2.2.12 Accelerated Embankment Construction](#)

[2.2.13 QA/QC, Quality Control for Prefabricated Concrete Elements](#)

[2.2.14 Cost Considerations](#)

[2.2.15 Listing of bridges replaced using ABC techniques](#)

2.2.1 Introduction

Oregon has a long history of employing ABC methods to quickly deliver bridge projects using a variety of techniques. Some were assembled or erected on temporary falsework located adjacent to an existing structure and skidded into place. This method allowed contractors to close the facilities to vehicular traffic for a relatively short time (a few days or weekend) and skid the bridge over after quickly demolishing the existing bridge at night and working through weekends. Other bridges over navigable waterways were replaced using barges to float new and whole superstructures into place (also known as switch out when an existing structure is replaced). For wider structures that can accommodate staged construction, precast concrete or concrete filled steel grid deck panels were installed using a partial closure of the roadway during off peak travel times.

A few Oregon ABC projects were designed with rapid construction in mind to limit traffic interruptions, but most were selected either based on VE proposals by contractors, incentive/disincentive provisions, or design-build contracts. Generally, the project schedules specified a relatively short window for closing or disrupting traffic operations on the facilities. The incentive/disincentive provision for each project was normally based on user delay costs as a function of AADT, detour length and other variables. Those projects have demonstrated ABC as an effective and efficient solution to alleviate congestion and/or long detours where conventional methods such as off-site detour, on-site detour, stage construction or slight realignment of the roadway were difficult or not feasible. They also resulted in improved public safety through a shortened work zone exposure.

2.2.2 ODOT encourages and supports ABC Projects

ABC methods can be defined as using prefabricated bridge elements, combining elements into systems, or moving a complete bridge span to quickly deliver a project and re-open a highway to traffic. Use of any of these methods are encouraged and supported by ODOT. A compiled list of past Oregon projects that described the ABC featured elements is provided here at the end of the Section for reference.

Construction activity results in delays to the public and incurs additional financial burdens on the people who must contend with the effects. This essentially results in a temporary tax on the affected neighborhood. Because of this, consider ABC methods even when it does not result in the lowest overall construction cost. Designers are encouraged to consider traffic delay costs and other user costs associated with a project to support stronger consideration of ABC methods. The ABC AHP Decision Making Program presented in *BDM 2.2.5* is available to assist in developing support for ABC.

Prefabricated elements consisting of deck panels, beams or girders, bent caps, pier columns and segments have been demonstrated successfully. Systems may consist of bridge components assembled and connected together to form a major portion or complete bridge span. Bridge movements such as incremental launching, skidding, and/or transport by self-propelled modular transporters (SPMT) of a partial/complete superstructure span are also found to be acceptable methods of construction. The guidance provided here will help designers and owners decide when and where ABC is appropriate as a method of project delivery. Although the Engineer on Record is responsible for the design as well as for developing a unique method of construction/movement to fulfill ABC requirements, the owner needs to be assured that quality and durability is not being compromised by the specific rapid construction technique being considered.

2.2.3 Contracting Methods Allowed

A contract for specifying ABC method of delivery is allowed and will continued to be allowed under the current design-bid-build specifications. A contractor may propose an alternate method of construction for approval by the EOR/owner as part of the Cost Reduction Proposal provisions in *SP 00140.70* of the Oregon Standard Specifications for Construction. The third option allowing ABC is provided under the design-build contract provisions. More discussions and guidance are provided elsewhere and will not be elaborated here.

2.2.4 Decision Making Framework

A successful ABC project is dependent on deciding correctly at the beginning of a project planning to assess when and where ABC would be most efficient and effective. The following criteria in the flowchart, *Figure 2.2.4*, for specifying a short window of closure may make ABC delivery the method of choice:

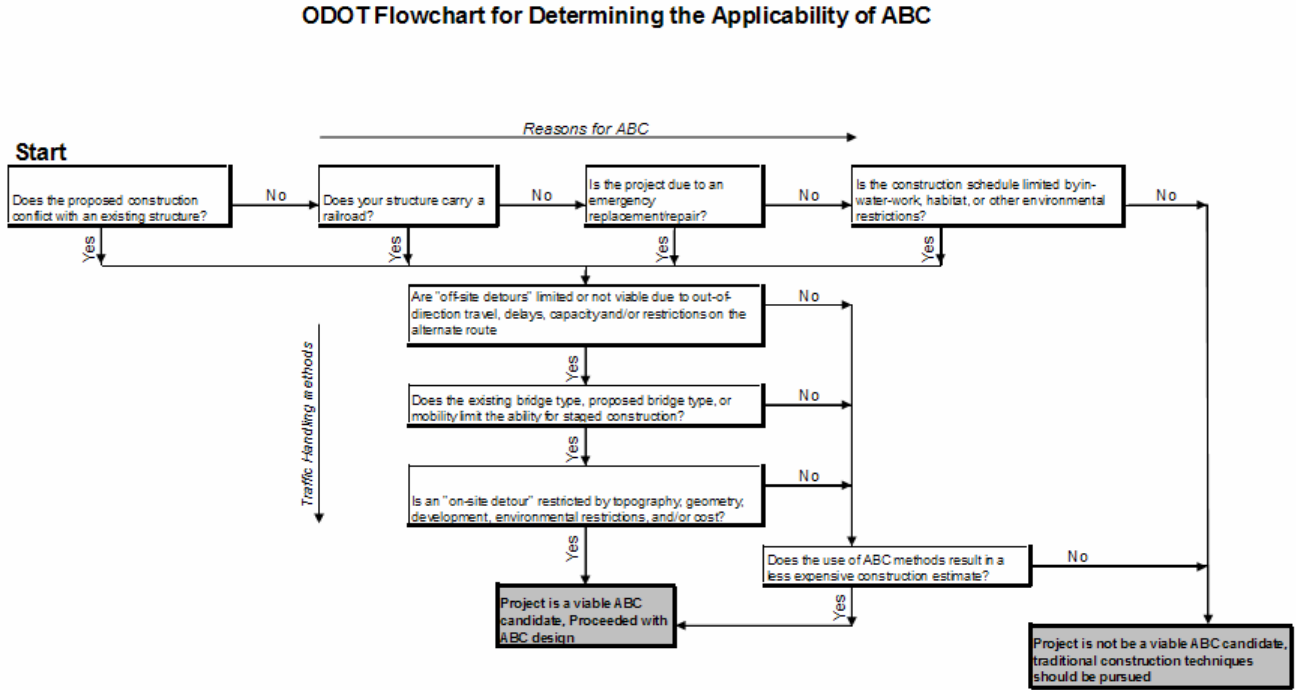

Figure 2.2.4

Bridge Design Manual – June 2020
Oregon Department of Transportation
Section 2 – Design Guidance

The following matrix is intended to help guide discussions when comparing ABC with conventional construction:

ATTRIBUTES	Accelerated BC (ABC)	Conventional BC (CBC)
1. Complexity	<ul style="list-style-type: none"> -Engineer less familiar with design required for accelerated bridge construction techniques -May require more surveys to establish control points -May require pick points for prefabricated bridges -May require more complex construction techniques -May need new specs -May add risk to Contractor -May require special equipment -Good with D/B and A+B with incentive/disincentive 	<ul style="list-style-type: none"> -Engineer more familiar with design required for conventional construction techniques; therefore, considered less complex. - Contractors more familiar with methods used in conventional construction, therefore considered less complex -Standard specs exists
ATTRIBUTES cont.	Accelerated BC (ABC) cont.	Conventional BC (CBC) cont.
2. Schedule	<ul style="list-style-type: none"> -Facility to reopen for traffic in hours or over weekends -Slightly longer design schedule due to complexity (see above) -Need more overall planning and coordination -Parallel construction off CPM -Typically can be done off-line and shorter field erection season, pending ABC method chosen. -Approach or utility work may control schedule if not outside CPM -Good with incentive/disincentive -Constructible connection details for precast elements such as bent caps, footings & pile heads require flexibility for field closure pours. -May require coordinated demolition plan for change-over structures -May require tight control of scheduling on critical items -The contract plan or designed details should be simple or the precast element detail may not fit. -May require industry participation in PBES/ABC to ensure successful transition to field application. -Include contractor on design or constructability review team. 	<ul style="list-style-type: none"> - Typical field construction season in months or years -Typical design schedule -Often bridge work is controlling in CPM -Sequential activities typical and limitations may exist -Public delay cost may be high
3. Budget	<ul style="list-style-type: none"> -May be more expensive in construction cost due to non-typical construction methods -May increase design cost -Limited historical bid item data -ABC can significantly reduce the costs to 	<ul style="list-style-type: none"> -Typical estimate given condition and conventional required structure type. -Typical standard project costs. -Incentives and disincentives may be included to accelerate construction and reduce traffic impacts but they may not

Bridge Design Manual – June 2020
Oregon Department of Transportation
Section 2 – Design Guidance

	<p>highway users associated with traffic queues and detours during the bridge installation.</p> <p>-The contract bid cost for an ABC project may be more than a conventional bridge project but overall may be much less when the savings due to reduced traffic impacts and delays are factored in.</p>	<p>be effective and could adversely impact project costs.</p> <p>-Careful analysis is needed to effectively apply incentive/disincentive methods to accelerate bridge projects.</p>
4. Design Quality	<p>-Design quality could be just as good as that of conventional</p> <p>-Limited design criteria for some elements</p> <p>-Construction loads may control design and need check</p> <p>-Require to show full connection details</p>	-Design quality is expected to be good from standard and best practice.
ATTRIBUTES cont.	Accelerated BC (ABC) cont.	Conventional BC (CBC) cont.
5. Construction Quality	<p>-Individual prefabricated elements are of higher quality under shop-controlled environment.</p> <p>-Construction quality could suffer in the field assembly due to time pressure.</p>	-Construction quality depends on the contractor and inspection staff.
6. Disciplines required	-May require more upfront coordination between technical and non-technical disciplines and public relations.	-Standard project design and construction teams
7. Experience needed	<p>-ABC experience is desirable especially regarding knowledge of ABC construction methods, new technologies and implementation of new design and details.</p> <p>-Additional research effort and resources may be required.</p> <p>-May require specialty construction experience.</p>	<p>-Standard project design experience.</p> <p>- Standard bridge construction experience.</p>
8. Public Communications	<p>-May require more early and upfront communication with the public for temp/short road closures</p> <p>-May need to develop a communication plan with stakeholders</p>	- Typical
9. Demolition of existing structure	<p>-Require full demolition plan</p> <p>-May need to provide staging place near site for off-line demolition</p> <p>-Coordination for change-over structures</p> <p>-May not require temporary structure to be in place for long duration</p>	<p>-Typical construction with either road closure or requires staging</p> <p>-Require full design of temporary structures for longer duration in place</p>
10. Quality Control	<p>-ABC elements should be verifiable during construction</p> <p>-May require constructability review</p>	-Typical
11. Owner Staff	-Some additional effort may be expected of the owner staff in design or review of non-conventional details/procedures. Also may require more staff in a much more condensed timeframe.	-Standard

2.2.5 ABC – Decision and Economic Modeling Analysis Tool using the Analytic Hierarchy Process (AHP)

ODOT has a tool for assisting project decision makers named “ABC AHP Decision Making Program”. This program allows the project team to analyze various applicable and weighted criteria in a paired-wise comparison. With input provided either by the designer or the project team, it captures the decision based on the controlling criteria and computed utility value for each criteria.

We encourage all project designers and/or leaders to take advantage of this useful tool as part of their decision making process to determine whether ABC is preferred over conventional construction. This program may be used with input provided by the bridge engineer alone if he or she has all the available information and feels comfortable to determine the relative importance between any two given criteria. When a project is complex and involves issues or concerns by other disciplines, it would be appropriate for the project team to provide input and thus build consensus in their decision making process. Input can be collected with a survey form or entered directly into the program data fields either during or after the project kick-off meeting or when more information become available for them to better gauge the relative importance between any given paired criteria or sub-criteria.

2.2.5.1 Instructions for using the “ABC AHP Decision Making Program”:

The AHP Program (in short) must be first loaded onto a personal desktop or laptop computer and must include the “dotNetFx40_Full_x86_x64.exe”. It is recommended the AHP Program be copied into a separate folder. It is assumed one is familiar through reading the manual (included in the CD folder) or attended the training. In summary, here are the logical steps to get started in running the program:

1. Individual or team to establish the applicable criteria and sub-criteria for ABC decision. Refer to *Figure 2.2.5.2* and mark the ones that apply to the specific project in question. Reminder: Always save your work.
2. Optional step: Use the survey form to assign the relative value for each paired-wise criteria comparison OR skip to next step.
3. Run the Program by clicking on “AHPTool.exe” file. This will open the program under Tab 1 (Decision Hierarchy) and de-select the non-applicable criteria and sub-criteria determined in Step 1. User can add a new criterion or remove one from the default by using the “add child” or “remove” button on the right.
4. Then click on Tab 2 (Pairwise Comparison) and enter the relative values from Step 2. Reminder: Always save your entries.
5. Click on Tab 3 (Results)
6. To use Tab 4, please read and follow instructions in the Manual.

2.2.5.2 Established Criteria and Sub-criteria for ABC decision

See *Figure 2.2.5.2*. Generally speaking, most transportation project decision making require some criteria that are important and specific to each site. Five main level criteria have been established and they seem to be the standard criteria used by several states for decision with ABC projects. Within each main level criterion is further defined by a sub-criterion that further expands to differentiate its elements. The definitions for each criterion are provided in Table 1 below.

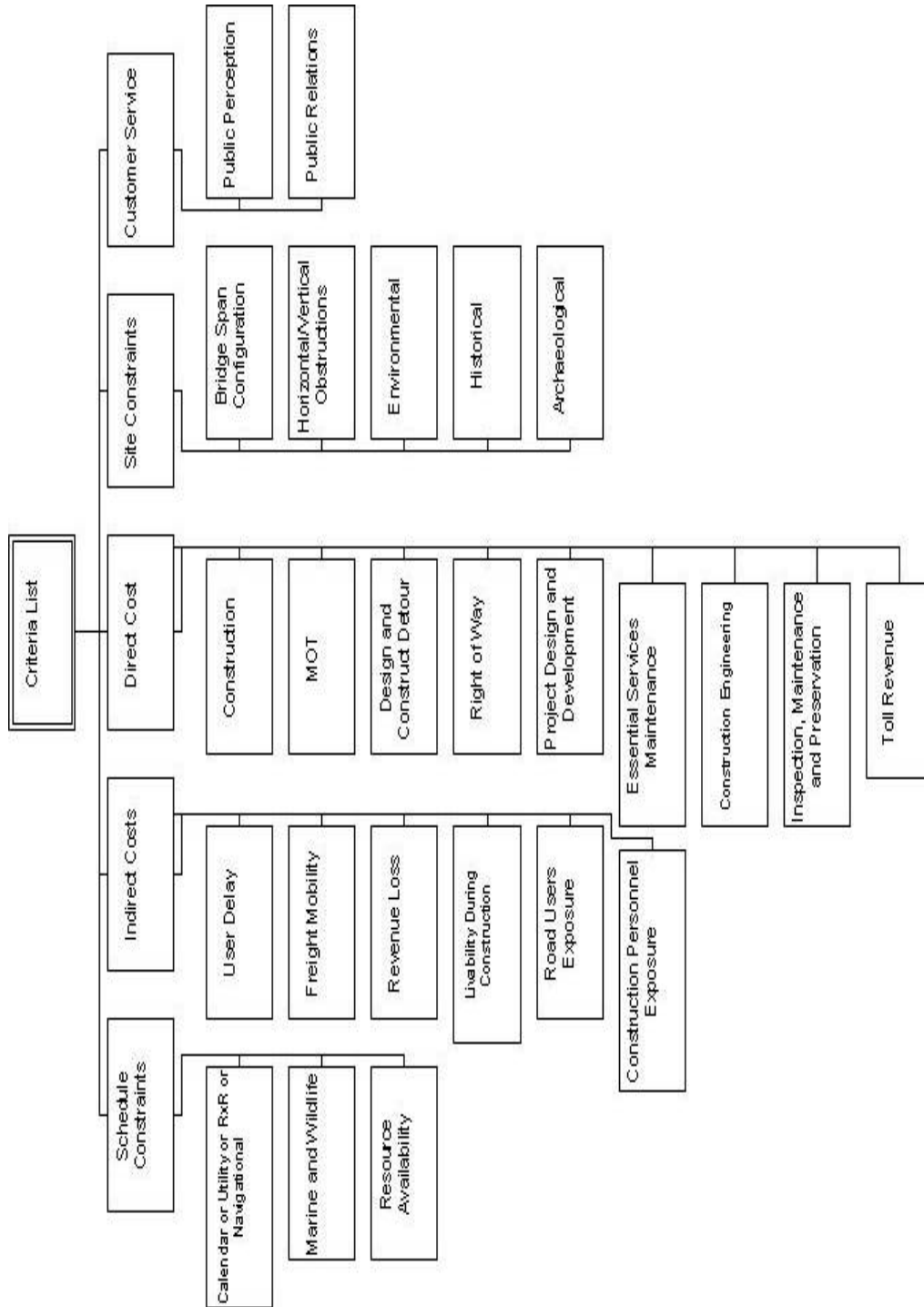

Fig. 2.2.5.2 – Main and Sub-Criteria for ABC Decision

Table 1 – Definition list of Main criteria and sub-criteria

Main criteria	Sub-criteria	Definition
Direct Costs	Construction	This factor captures the estimated costs associated with the construction of the permanent structure(s) and roadway. This factor includes premiums associated with new technologies or innovative construction methods. Premiums might result from factors such as contractor availability, materials availability, and contractor risk. It may include incentive/bonus payments for early completion and other innovative contracting methods.
	Maintenance of Traffic (MOT)	This factor captures the maintenance of traffic costs at the project site. MOT costs may impact preference due to its impact on total costs. This factor includes all costs associated with the maintenance of detours before, during, and after construction. Examples of this factor include; Installation of traffic control devices, maintenance of detour during construction including flagging, shifting of traffic control devices during staged construction, restoration associated with the temporary detours upon completion of construction.
	Design and Construct Detours	This factor captures the costs to design and construct temporary structures and roadways to accommodate traffic through the project site.
	Right of Way (ROW)	This factor captures the cost to procure ROW. This factor includes either permanent or temporary procurements/easements.
	Project Design and Development	This factor captures the costs associated with the design of permanent bridge(s) and costs related to project development based on the construction method.
	Maintenance of Essential Services	This factor captures the costs associated with the need to provide essential services that may be impacted by the construction selected. Examples of this factor include alternate routes or modes of transportation to provide defense, evacuation, emergency access to hospitals, schools, fire station, and law enforcement, etc. This criterion is for situations where measures needed to be implemented beyond those already considered in the “MOT” and “Design and Construct Detours” criteria.
	Construction Engineering	This factor captures the costs associated with the owner’s contract administration of the project.
	Inspection, Maintenance and Preservation	This factor captures the life cycle costs associated with the inspection, maintenance and preservation of individual bridge elements.
	Toll Revenue	This factor captures the loss of revenue due to the closure of a toll facility.

Bridge Design Manual – June 2020
Oregon Department of Transportation
Section 2 – Design Guidance

Main criteria cont.	Sub-criteria cont.	Definition cont.
Indirect Costs	User Delay	This factor captures costs of user delay at a project site due to reduced speeds and/or off-site detour routes.
	Freight Mobility	This factor captures costs of freight delay at a project site due to reduced speeds and/or off-site detour routes.
	Revenue Loss	This factor captures lost revenues due to limited access to local business resulting from limited or more difficult access stemming from the construction activity.
	Livability During Construction	This factor captures the impact to the communities resulting from construction activities. Examples include noise, air quality, and limited access.
	Road Users Exposure	This factor captures the safety risks associated with user exposure to the construction zone.
	Construction Personnel Exposure	This factor captures the safety risks associated with worker exposure to construction zone.
Schedule Constraints	Calendar or Utility or RxR or Navigational	This factor captures the constraints placed on the project that might affect the timing of construction as a result of weather windows, significant or special events, railroad, or navigational channels.
	Marine and Wildlife	This factor captures the constraints placed on the project by resource agencies to comply with marine or wildlife regulations. Examples include in-water work windows, migratory windows, and nesting requirements.
	Resource Availability	This factor captures resource constraints associated with the availability of staff to design and oversee construction. For example, a state may be required to outsource a project, which may result in additional time requirements.
Site Constraints	Bridge Span Configurations	This factor captures constraints related to bridge span configurations. This element may impact owner preference regarding bridge layout, structure type, or aesthetics.
	Horizontal/Vertical Obstructions	This factor captures physical constraints that may impact construction alternatives. Examples include bridges next to fixed objects such as tunnels, ROW limitations, sharp curves or steep grades, or other urban area structures that constrain methods and/or bridge locations.
	Environmental	This factor captures the constraints placed on the project by resource agencies to minimize construction impacts on natural resources including marine, wildlife, and flora.
	Historical	This factor captures historical constraints existing on a project site.
	Archaeological Constraints	This factor captures archaeological constraints existing on a project site.

Main criteria cont.	Sub-criteria cont.	Definition cont.
Customer Service	Public Perception	This factor captures both the public's opinion regarding the construction progress and their overall level of satisfaction.
	Public Relations	This factor captures the costs associated with the communication and management of public relations before and during construction.

2.2.6 Steel Structures

Steel structures are excellent examples of prefabricated bridge elements and systems. They are proven to be cost effective for ABC applications. Steel girders are prefabricated and prime-coated as needed in the shop and shipped to the job site. A short closure of the affected highway facility may be required to erect them. Complete arches and trusses have been erected successfully on barges and floated into place.

Bridges built with plate girders (straight or curved) can accommodate precast concrete panels or steel grid deck systems for rapid construction. Sample connection details can be found at:

www.fhwa.dot.gov/bridge/prefab/

2.2.7 Concrete Structures

2.2.7.1 Prestressed and Precast Concrete (PPC) versus Cast-In-Place (CIP)

PPC bridge elements are typically mass produced in a PCI-certified plant under factory-controlled conditions. This results in a high quality product. PCC products can be transported to the jobsite for just in time delivery, thus avoiding re-handling or the need for storage space that might be difficult to provide in urban areas. Traffic impact at the project site can be minimized and erection can normally be done during off peak hours.

In Oregon, construction cost for PPC girders is lower than CIP girders. Unless there is a compelling reason like curvature, aesthetics, and longer span requirements, PPC girders are preferred. There is economy of scale for larger projects requiring repetition of similar spans. For elements other than girders, there is opportunity to develop effective standard elements for connecting them into bridge systems. In the erection of PPC elements, proven connection details are critical for long term performance. The FHWA has developed a manual on proven connection details. See:

www.fhwa.dot.gov/bridge/prefab/

2.2.8 Full Depth Deck Panels, End Panels or Approaches and Wingwalls

Full depth deck panels are used by many states. Connection details for both steel and concrete girders exist. A survey of details used by various states was published in 2006 as NCHRP 12-65. ODOT has constructed multiple projects using full-depth precast concrete deck panels, but has not yet settled on a standard detail. ODOT does not allow partial-depth precast deck panels.

ODOT has existing standards for end panels/approaches and wingwalls that can be readily converted into ABC.

Precast End Panels

- Consider issues regarding subgrade compaction and the contractors' ability to construct the surface of the subgrade to a smooth level condition prior to placement.
- Consider the ability of precast panels to accommodate differential settlement (especially if subgrade is not level)
- Consider the design of the connection detail to pile cap/abutment wall and any joint construction.

2.2.9 Precast Connections in Seismic Regions

When assembling prefabricated bridge elements on site, a detailed assembly plan may be needed. For single span bridges assembly is typically not complicated. For multi-span bridges, designing and detailing of connections has to be treated with the same importance as designing the rest of the structure.

Submit new connection proposals for approval to ODOT Bridge HQ. This requirement is intended to ensure information about good connection details are subsequently distributed to other design groups. Research into new connection details has been ongoing with special concern for finding details that perform well under seismic loading. The NCHRP 12-74 research project "Development of Precast Bent Cap Systems for Seismic Regions" identified a number of bent cap-to-column details that hold promise for seismic applications. Their conclusions were released in 2011 as NCHRP Report 681. ODOT is willing to implement a few of these details only for bridges in low-to-moderate seismic regions (Seismic Zones 1, 2 or 3):

- a) Grouted Duct – Grouted duct connections consist of bent caps which have corrugated ducts to accept reinforcement extending from supporting substructure elements.

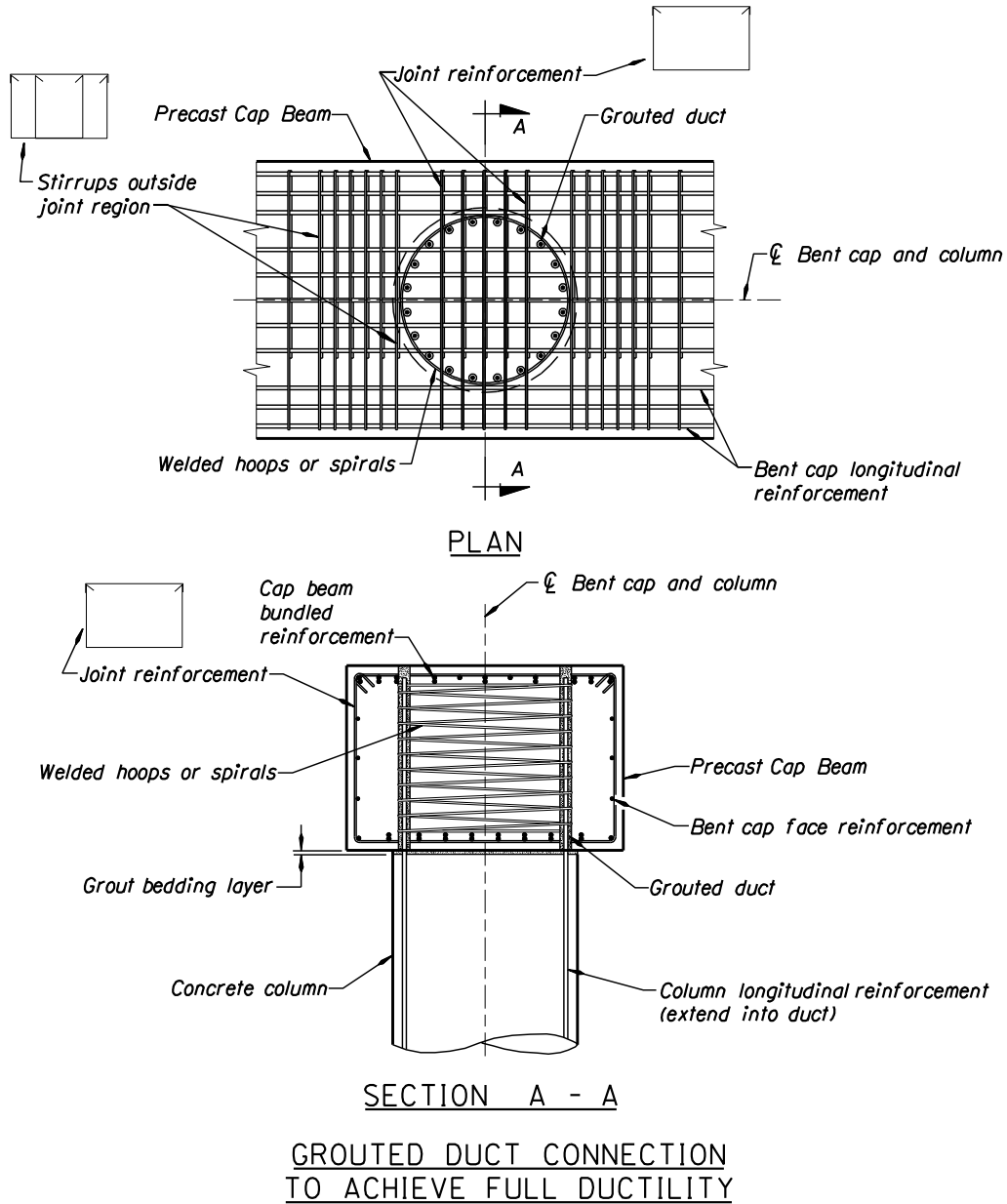
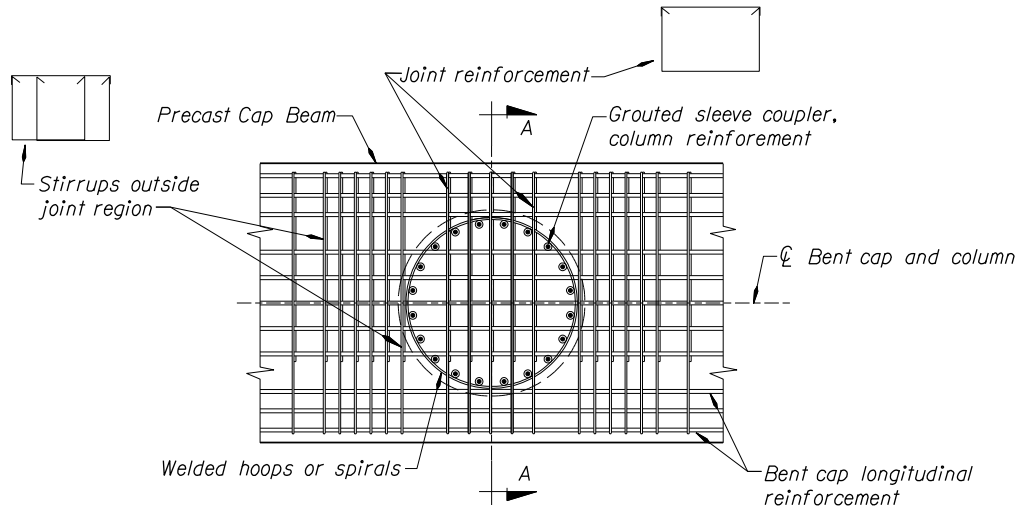
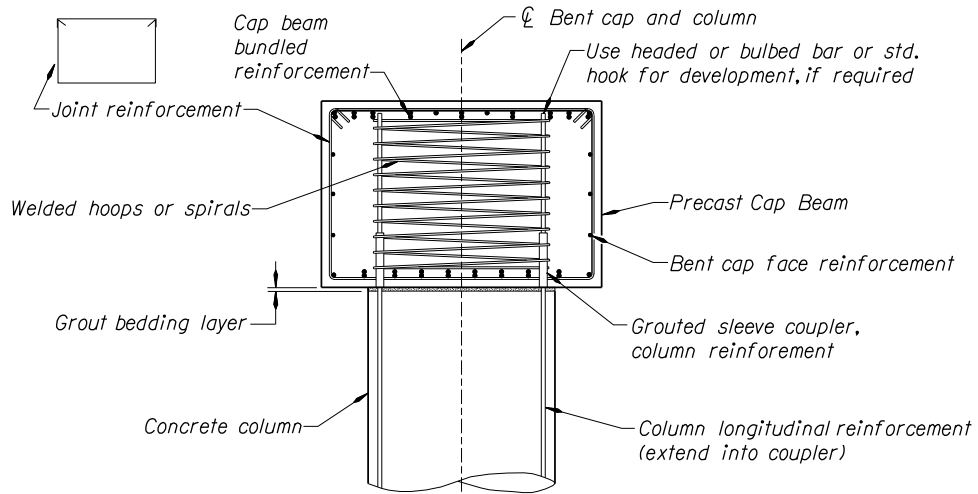

Figure 2.2.9A

- b) Grouted Sleeve Coupler (Coupler in Cap) – Proprietary grouted sleeve couplers are used to connect reinforcing bars in precast concrete components. These couplers are placed in the bottom-half of the precast bent cap and are designed to withstand forces at overstrength as is often required in plastic regions.



PLAN



SECTION A - A

GRouted SLEEVE COUPLER CONNECTION
TO ACHIEVE FULL DUCTILITY

Figure 2.2.9B

2.2.10 Use of Self-Propelled Modular Transporters (SPMT)

SPMTs can support and move heavy loads using a flat-bed mounted on multi-axle, independent suspension and steering wheel lines. They have the ability to maneuver in difficult and uneven terrain with unmatched precision and distortion control of the payload.

SPMTs can move complete superstructure spans from a staging area (e.g. gore area or off the shoulders) to the final bridge location. A bridge move can be performed on weekends or at night using the SPMTs to erect a structure into final position within a matter of hours. FHWA has a user guide manual as a resource for anyone contemplating an ABC project using SPMTs. The guide is available free of charge at:

<http://www.fhwa.dot.gov/bridge/pubs/07022/>

2.2.11 Geotechnical Considerations

Geotechnical designers need to consult closely with the bridge designer and the project team regarding the use of ABC methods at a particular bridge site. Continue to coordinate these efforts as necessary during the bridge design process.

Driven piling is normally the most rapidly constructed foundation type. However, piles are not suitable at every location. The most suitable foundation type for a bridge replacement or widening project depends on several factors including the subsurface materials and conditions, construction or environmental constraints and cost. Refer to the ODOT GDM; Chapter 8 for additional guidance regarding the selection of foundation types. Once the most suitable foundation type is selected for a site, thought should be given to how the foundation construction can be expedited. This should include how to minimize traffic impacts due to foundation construction. At some locations the foundations (and substructure elements) may be constructed under, or away from, the existing bridge thereby avoiding, or minimizing, any traffic impacts. If this scenario is possible, the time required for foundation construction may be less significant because it does not directly affect traffic. At sites where foundation construction will directly impact traffic and multiple foundation types are possible, consideration should be given to the foundation system that can be constructed in the least amount of time and with the least impact to traffic. Some general guidance regarding the use of various foundation systems in ABC applications are described below.

2.2.11.1 Spread Footings

Conventional Spread Footings

- Requires excavation to suitable foundation materials which may result in the need for large excavation areas and/or temporary shoring and possibly dewatering.
- Requires setting rebar, a concrete pour and curing time (and form work, if needed).

Precast Reinforced Concrete Spread Footings

This type of ABC foundation system is currently under development. Design and construction standards and specifications do not currently exist. This type of foundation may be considered at sites where conventional spread footings would be appropriate. Precast spread footings (PSF) are currently recommended only for shorter, single span bridges at this time. Issues to consider in the application of precast spread footings would include:

- Need for construction of a concrete footing leveling slab beneath the precast footing (excavation/shoring, sloping bearing strata, presence of groundwater, etc.),
- Design of the connection between PSF and leveling slab,
- Design of the connection between the PSF and columns or abutment walls,
- Constructability issues when placing PSF directly on compacted soils,
- LRFD resistance factors for bearing and sliding resistance based on construction method, and settlement analysis.

2.2.11.2 Driven Piles

Often the quickest foundation construction method and can generally have the least impact and disruption to traffic.

- Consider using fewer, higher capacity, piles per bent to expedite construction, however:
 - Using higher capacity piles may result in significantly higher foundation costs due to the need for larger pile driving hammers, leads and cranes and possible effects on the cost of work bridges due to these higher loads.
 - Using less than 5 piles per bent may result in a reduced LRFD resistance factor due to less redundancy.
 - May be most appropriate for sites with relatively short end bearing piles.
- Requires assessment of pile top alignment tolerances for precast pile cap connection:
 - Standard specifications (*SP 00520.41(f)*) allow for a horizontal alignment tolerance of 6 inches from the plan location. If a smaller tolerance is required this reduced tolerance must be specified in the special provisions. Consult with the project geotechnical engineer regarding allowable horizontal tolerances for driven piles.
 - Should piles be installed in prebored holes to meet the specified tolerances? Keep in mind the final pile alignment is only as good as the prebore hole alignment. In soils where large cobbles and/or boulders are present, or where preboring will encounter a bedrock unit with a sloping surface, prebored holes should not be augered but instead excavated using core drilling equipment. Augers tend to wander uncontrollably in these materials and borehole alignment is very difficult to maintain.
 - Consider the time and cost of preboring.
 - Consider the risk of not preboring (possibly include preboring as an anticipated item).
- Minimize the potential for in-lead splices, particularly on pile with a wall thickness of greater than 0.50 inches such that extensive welding and welding QA/QC is not required.
- Increasing estimated lengths in variable subsurface conditions will help reduce the likelihood of an in-lead splice for pile shorter than 60 feet. For longer pile consider specifying that the pile be fabricated (spliced) on site prior to putting in the leads, taking into account the cost of using larger size leads and cranes and other concerns similar to those discussed above when using fewer high capacity pile.

- Piles can be installed in existing travel lanes, in stages under traffic control, and covered over with temporary steel cover plates to keep travel lanes open to traffic until the time for substructure construction.
- At water crossings consider a trestle pile design which eliminates the need for a cofferdam (if an above ground pile cap is permissible). Potential for drift buildup should be assessed relative to the use of a trestle pile system. A web wall may be required if drift potential is significant.

2.2.11.3 Drilled Shafts

- Usually takes the most time to construct. Drilled shafts are often the best method for rapid in-water foundation construction, since they may omit the need for a cofferdam (unless required for environmental considerations).
- Consider fewer, higher capacity, shafts per bent, (*note that appropriate modifications to LRFD resistance factors are required for bents with less than 2 shafts*).
- Higher potential for increased risk of time delays due to problems with shaft construction or negative NDT results.

2.2.11.4 Micropiles

- Usually more expensive than other foundation types.
- Suitable for certain ground conditions, particularly manmade unconsolidated rock fragment fills and low overhead clearance areas.
- May be installed to tight tolerances and drilled through pavement sections.
- Consider environmental concerns relative to spoils recovery since water is typically used to flush out cuttings.

2.2.12 Accelerated Embankment Construction

The time required for embankment construction, (either an all new roadway embankment or a widening section) depends primarily on the volume of material required, the type of embankment materials used, the level of contractor effort and the subsurface conditions at the site. Other factors such as access, retaining wall construction and weather can also play a role and affect the speed at which an embankment can be constructed. Embankment construction may be accelerated in a number of ways. In areas where very soft ground conditions exist there is potential for significant settlement and stability issues. Consideration should be given to extending the bridge structure over these areas. This may result in a better overall design with less environmental impacts and a shorter construction period.

For ABC projects, the geotechnical engineer is responsible for evaluating the site conditions and project requirements to determine the most effective way of expediting embankment construction with the least impact to traffic flow and mobility. Refer to ODOT GDM; Chapter 9 for more design guidance on the analysis and design of embankments. ABC projects often replace bridges in the same location (same horizontal alignment) as the existing bridge with the new bridge being wider. Therefore approach embankments also need to be widened. The grade may also be raised resulting in a further increase in embankment widening. Depending on the site constraints (available access/ROW, adjacent structures, wetlands, etc) this widening can often be accomplished with minimal traffic impacts. The geotechnical

engineer plays a key role in the design of these widened sections to help determine the best approach for expediting construction while taking all appropriate geotechnical design requirements into account.

The need for retaining walls on a project should be carefully reviewed. Typically an embankment can be constructed quicker than a retaining wall. Retaining wall needs are typically driven by roadway “typical section” needs that may not have been optimized to reduce the need for retaining walls. For example, the slope immediately behind a guardrail could be steepened from the typical 1V:3H or 1V:4H to steeper slopes if longer (8’) guardrail posts are used rather than the typical 6 foot post lengths. Often typical fill slope rates of 1V:2H are considered in typical sections. Steeper slopes, when permitted, may omit or reduce the need for a wall. Use of stone embankment material may allow fill slopes to be constructed as steep as 1V:1.5H. If so, 8 foot metal guardrail posts may be needed to assist in penetrating the stone embankment material.

Retaining walls may be proposed in some areas to avoid, or minimize, environmental impacts. The need for walls in these areas should be closely evaluated, in consultation with the appropriate environmental specialists, to determine the underlying reasons for requiring a wall and whether or not it is the best solution for the specific location.

Some suggested considerations for embankment construction on ABC projects are summarized below:

- Use “All-Weather Materials” (stone embankment) instead of common “borrow” materials where available and appropriate. This allows construction to rapidly proceed regardless of wet weather conditions and can greatly reduce the total embankment construction time.
- Soft Ground Conditions (settlement and stability issues)
 - Lightweight fill material such as geofam
 - Geogrid reinforced embankments
 - Ground improvement techniques
 - Surcharge, with or without vertical wick drains

2.2.13 QA/QC, Quality Control for Prefabricated Concrete Elements

2.2.13.1 Types

ODOT has used a variety of prefabricated concrete elements on many projects. Prestressed concrete elements have been used since the 1960s. Use of non-prestressed prefabricated concrete elements dates back even earlier. The types of prefabricated concrete elements used on ODOT projects have included:

- Prestressed slabs and box beams
- Prestressed girders
- Prestressed columns
- Prestressed arch ribs
- Prestressed piles
- Bridge railing
- Bridge end panels
- Pile caps/abutments
- Stay-in-place deck forms
- Culverts
- Manholes and utility vaults

2.2.13.2 Prestressed Elements

When precast concrete elements include prestressing, *SP 00550* of the standard specifications apply. *SP 00550.05* requires fabricators to be certified under the PCI Plant Certification Program. PCI certification ensures that industry best practices are followed. The member tolerances specified in *SP 00550.04* are those recommended by PCI.

For non-standard prestressed concrete elements, the existing *SP 00550* Oregon Standard Specifications for Construction will likely be adequate without modification. The designer may need to create a unique bid item since the available bid items only cover our current standards.

Verify new or modified details with local precasters (Knife River and/or R.B. Johnson Co.) before design plans are final. Also confirm with the ODOT Structural Materials Engineer whether standard inspection procedures are adequate.

2.2.13.3 Non-Prestressed Elements

Specify concrete elements that are not prestressed under *SP 00540*. Since there is not a nationally recognized certification program for non-prestressed elements, the designer will need to determine some minimum qualifications for fabricators. Minimum qualifications may include:

- Submission of a Quality Control Plan
- Names and qualifications of key personnel
- History of similar projects
- Procedure for tracking material certifications

The nature and complexity of the project will determine which items above should be included in the minimum contractor qualifications. Solicit input from the ODOT Bridge Materials Engineer before finalizing any contract special provisions.

In addition to project qualifications, it may be desirable to require the contractor to identify the form material and forming details. Lifting and shipping details may also be required. For unique lifting and shipping situations and/or large elements, it may be necessary to require verification of lifting and shipping details. Such verification could be achieved with review by a professional engineer or by testing. Especially where there is potential for items to be fabricated by a contractor with little or no experience with precasting concrete, include special provision language to clarify any requirements that ensure safe and adequate lifting and transport details. In some cases, it may be desirable to add lifting and shipping verification as part of the contractor's Quality Control Plan.

Where precast concrete elements are specified under *SP 00540*, a special provision will be needed to address measurement and payment. Most structural concrete is paid on a cubic yard basis. However, precast concrete elements are typically paid either on a per length basis or per each.

Standard fabrication tolerances for structural concrete are provided in *SP 00540.40*. These tolerances are based on typical cast-in-place concrete construction. For precast elements tighter tolerances may be achievable and desirable. Consult with the ODOT Bridge Materials Engineer to determine reasonable tolerances for your specific application.

Inspection of precast concrete elements is required both during the precasting operation and during placement in the field. The ODOT Bridge Materials Engineer is responsible for inspection of precast elements and should be notified when precast concrete elements are to be used. This will help ensure ODOT staff is scheduled to be available for such inspections and whether any adjustment to the ODOT Nonfield-Tested Materials Acceptance Guide is needed.

2.2.13.4 Connection Issues

Current state-of-the art does not support connection of precast cap elements in high seismic locations. This is currently being researched at the national level.

Connection of precast elements may involve the use of grout pockets to emulate cast-in-place construction. Where grout pockets are used, manufacturer's recommendations should be followed regarding when grout should be extended with aggregate. For many grout products, aggregate is recommended when the pocket size reaches 2 inches or more.

2.2.14 Cost Considerations

It has been determined by numerous projects nationally that accelerating a project delivery will reduce the costs to highway users associated with traffic queues and detours during the bridge installation. Utah DOT has demonstrated that ABC can be successful and the initial costs of innovation are absorbed on the first few projects when there is some assurance that more projects using the same technology are being planned for the near future. The use of ABC should be justified on a specific project by analyzing the user cost savings compared to the estimated cost of various methods of rapid construction (see HYRISK discussion below).

ODOT has posted a Work Zone Traffic Analysis Tool that considers such topics as traffic delays and operations, and long detours. [Guidance on Incentive/Disincentive Program](#) for designers is also available.

2.2.14.1 Incentive/Disincentive Program

Requirements related to reduced traffic impact and time must be clearly specified in the contract documents. Innovative contracting strategies to achieve accelerated construction include incentive/disincentive, a financial bonus or penalty for delivery before or after a time set in the contract; A+B bidding, cost-plus-time based on the combination of contract bid items (A) and the time bid for construction multiplied by daily user cost (B); lane rentals, assessed rental fees for lanes taken out of service during temporary lane closures for construction; and no-excuse bonus, a modified incentive with no time adjustment for problems such as delays due to weather or utility conflicts regardless of who is responsible.

Incentives and disincentives for early completion give contractors a financial reason to change their conventional practices to accelerate construction. Contractors cannot count on incentives and, therefore, may not reduce their bid price in anticipation of receiving incentives. Disincentives are necessary but may result in higher bid prices because of the risk to contractors that they will not be able to meet the reduced construction timeline. In some accelerated bridge project case studies, it was found that by providing the right incentive/disincentive, contractors were able to lower overall total project costs when compared to conventional delivery methods.

2.2.14.2 Maintenance of Traffic Costs

Traffic management and user delay-related costs associated with bridge construction activities will significantly influence the selection of the most cost-effective bridge technology.

Elaborate traffic control plans can significantly add to the cost of replacement, especially when the traffic control plan changes significantly during the project due to development, local expansion, or other projects in the area. Cost savings from the reduced duration of the traffic control plan through the use of ABC method of delivery can be estimated based on the reduced number of days of traffic control cost times the average daily operating cost of such measures for comparable bridge projects.

2.2.14.3 Contractor’s Operation Costs

In general, contractors bid projects with the plan to complete onsite construction as quickly as possible to increase profits. This is particularly true for projects with incentives for early completion. The contractor’s costs, including overhead costs to staff projects, are reduced when the duration of the construction project is reduced. Also, construction crew safety in the work zone is increased with reduced exposure times.

2.2.14.4 Owner Agency’s Operation Costs

Agency overhead costs to staff projects, e.g., construction engineering and inspection support, are reduced when the duration of construction projects is reduced. Prefabricated bridges, with their rapid onsite installation, can significantly reduce these project costs.

The use of prefabricated bridges to accelerate construction cannot be approached in a conventional manner by the owner. The owner will need to commit to working multiple shifts, odd hours, and under the same constraints as the contractor.

The manufacturers of prefabricated components may be able to offer lower unit costs if they can spread their fixed costs over many bridges and/or reuse formwork repeatedly. Bundling projects provides an attractive incentive for a contractor to acquire new or special equipment when he can recoup his investment on multiple applications.

2.2.14.5 Available Tool: HYRISK

How much will it cost highway users if a bridge is closed or detoured? The bridge with the longer detour requires additional time and mileage costs to negotiate the detour, and incurs the most cost to users. The cost of bridge construction alone fails to capture the total cost of the project.

A method that blends bridge construction cost and the users economic losses associated with a bridge construction is discussed below using HYRISK algorithm to compute the economic impact to a community.

AADT and detour length are extracted from the NBI record for the bridge. The assumed 2008 cost per distance traveled was equal to \$0.44/mi (\$0.27/Km). It is assumed that the project would have one year duration of the detour.

Detour Mileage Cost (DMC) = Duration * Length Detour (L) * Cost/Length (CpL) *ADT	
Sample Bridge Project (Br # 00138)	
Duration of facility for construction (D) in days	365
Detour length (L) in km	26
Cost per Mile per Vehicle driven of detour length (CpL)/km	\$0.27
Annual Average Daily Traffic (AADT)	330
Time cost per person (TcP)/hr	\$16.31
Occupancy rate (person) per vehicle (O)	1.56
Time cost per truck (TcT)/hr	\$29.50
ADTT (Truck Traffic as a percentage of AADT; i.e. 10% this case)	.10
Speed of Traffic on Detour (DS) in km/hr	64
Detour Mileage Cost (DMC) = D*L*CpL*ADT	\$845,600
Detour Time Cost (DTC) = D*L*[(O*TcP)*(1-ADTT)+(ADTT*TcT)]	\$1.265 M
Total Community Cost associated with bridge closure T1 _{cost} =DTC+DMC	\$2.11 M

Bridge Design Manual – June 2020
Oregon Department of Transportation
Section 2 – Design Guidance

2.2.15 Listing of bridges replaced using ABC techniques:

Contact ODOT's ABC specialist or the Bridge Design Standards Engineer to request a project be added to the list. Plans for these projects can be found using BDS (Bridge Data System).

BDS Structure Number	Year Built	Region	Project Title	ABC Technique Used
BR22163	2014	5	Whiskey Creek, Wallowa County	PS Slabs on steel pile caps – 2- week road closure.
BR22057	2014	2	US 26 West Humbug Creek Bridge	Used precast and prefabricated elements. Precast deck panels.
BR22105	2014	5	OR 203 Branch of Ladd Creek Culvert	Inverted rigid frames with precast prestressed slabs as top panels, 30-foot spans. Used short bypass 2-lane detour.
BR00711	2013	2	US101B Lewis & Clark River Bridge	Partial ABC with CIP deck. Used some precast and prefabricated elements.
BR21548 BR21549	2012	5	US 26 Dean and Dog Creek Culverts	Inverted rigid frames with precast top slabs to form a single cell box, 16-foot span. Used centerline shoring.
BR21252	2012	5	US30 Burnt River (UPPR)	Precast PS Deck Panels with UHPC joints and connections. Steel diaphragms. FHWA Demo Project for Life Grant.
BR21439	2012	3	Hwy 1 Kane Creek Frtg Road LT (Old Stage Road)	Precast pile caps, end panels and wingwalls.
BR21493	2011	1	Sellwood Bridge, Willamette River	Slide bridge into place using "Shoo Fly" technology. SellwoodBridge.org
BR21188	2010	2	US26 Volmer Creek Bridge	All precast or prefabricated elements (staged construction).
BR21189	2010	2	US26 Johnson Creek Bridge	All precast or prefabricated elements (staged construction).
BR20584 BR20585	2008	3	OR 38 over Elk Creek Bridges near Elkton	1 steel plate, 1 Bulb-T girder bridge built on temporary falsework adjacent to the existing. Skidded on tracks during two weekend road closures.
BR20586	2008	3	OR 38 Bridge over Hardscrabble Creek, Douglas County	Bridge built adjacent to the existing and skidded into place.
BR02398	2008	5	Kimberly Bridge OR19, Grant County	Rapid replacement of 2 approach spans using precast pile caps on a long structure with 20-day full road closure.
BR01132 F	2007	3	Hwy 241 Isthmus Slough (east side)	Constructed substructure around existing bridge.
BR19273	2007	3	Depot Street Bridge over the Rogue River, Jackson County	306-foot concrete arch built adjacent to existing bridge and skidded into place. Road closed for 5 days.
BR20136	2007		Sauvie Island Bridge over Columbia River, Multnomah County	365-foot steel tied arch. SPMT used to skid and load bridge on barges and floated span into place.
	2007	1	OR 47 over Dairy Creek Overflow Bridge, Washington County	Used steel pile cap and reused salvage precast, prestressed slabs. Road closed for 14 days.
BR20238	2006	2	US 20 Bridge over Hayes Creek, Eddyville, Lincoln County	Used precast cap and slabs. Bridge constructed during a 72-hour road closure.
BR00711	2004	WSDOT Lead	Lewis & Clark Deck Replacement	SPMT used to replace superstructure 5478' L X 34" W, 34 panels. Conventional method duration was 4 years. Using ABC, done in 6 months with full road closure.
BR01660	2002	4	OR 26 Mill Creek Bridge Deck Replacement, Wasco County	3-span continuous truss with deck panels. Panels replaced sequentially with partially concrete filled exodermic steel grid deck. 540-foot deck replaced in 24 days under flexible road closure schedule.
BR07333	1997	1	I-5 (Interstate) Bridge over Columbia River, Multnomah County	Accelerated replacement of 2 trunnion assemblies and span/counterweight cables. Contractor awarded \$1.4+M incentive (\$100K/day) for early completion in less than 7 days; 14 days ahead of the required 21-day schedule.
BR18074	1997	5	Imnaha Bridge over Little Sheep Cree	Single span, concrete-filled grid deck over steel curved girder bridge. Built first half of new bridge and switched traffic over; demolished existing bridge and built second half with skidding to connect the two halves. Longitudinal concrete closure-pour in the middle
BR02529	1973	1	Freemont Bridge over Willamette River, Multnomah County	Arch span was floated on barges and moved into place using strands jacking.
			Sam Jones Bridge	Full depth precast deck panels.

2.3 STRUCTURE APPEARANCE AND AESTHETICS

[2.3.1 General](#)

[2.3.2 Location and Surroundings](#)

[2.3.3 Horizontal and Vertical Geometry](#)

[2.3.4 Superstructure Type and Shape](#)

[2.3.5 Bent Shape and Placement](#)

[2.3.6 End Bent Shape and Placement](#)

[2.3.7 Parapet and Railing Details](#)

[2.3.8 Colors](#)

[2.3.9 Textures](#)

[2.3.10 Ornamentation](#)

[2.3.1 General](#)

Keep in mind the structure appearance with respect to its surroundings and the context of the site.

ODOT has no general directive or mandate on aesthetics or aesthetic design. This section is a guideline to generally accepted practice.

Generally for bridges, appearance is best when elements are few and simple.

Bridge elements are pleasing when the structural intent is clear with respect to the size and shape of the element. Elements forced into a non-structurally responsive shape for decoration are not considered aesthetically pleasing and may be a significant distraction and a safety hazard. Decorations on bridges that are not part of the structural support system may not be maintained to the same level as the structural portions of the bridge unless a separate IGA is executed with a local agency for maintenance.

Aesthetics and environmental considerations may have apparent conflicts. Historic or environmental issues may impact the bridge rail type, structure configuration, type of foundation or bent placement. Start the permit application and coordination process for historic structures as early as possible in the design stage. Aesthetics concerns, especially within an existing documented site context, are valid issues that can and should impact resource agencies permitting considerations.

There is a misconception that improving appearance always costs more. This is not necessarily true. The challenge to the engineer is to use creativity and ingenuity to improve the appearance without increasing cost. When people think that improved appearance is going to add costs, they are generally thinking in terms of add-ons, special ornamental features or special colors. The greatest aesthetic impact can be made by the structural elements themselves. These are seen first, and at the greatest distance. The bridge can be made attractive if these major elements are well shaped, and if they fit in well with the surroundings.

The following topics are commonly known to assist in producing visually pleasing structures. They are discussed in more detail in the following sub-sections.

- Location and surroundings
- Horizontal and Vertical Geometry
- Superstructure Type and Shape
- Bent Shape and Placement
- End bent Shape and Placement
- Parapet and Railing Details
- Colors
- Textures
- Ornamentation

2.3.2 Location and Surroundings

When determining the appearance of a bridge, the bridge must be considered in context with its surroundings. Decisions need to be made regarding what color, shape and type of bridge will look best at a given location. The surrounding area may be industrial, urban, or rural. A bridge that looks pleasing in a rural setting may look totally out of place in an urban area.

Individual bridges that span a major land area or body of water, because of their large size, dramatic location, and carrying capacity, will tend to dominate their surroundings. While these structures must harmonize with the surroundings, their importance and size requires that the aesthetic qualities of the structure stand on their own. Multiple bridges seen in succession create a cumulative aesthetic impact on the landscape that must be considered. In these situations, there is more reason for uniformity, and there should be no noticeable differences between structures, without an obvious reason. A specific theme for a particular route, such as a parkway, is often appropriate.

Routine bridges, such as highway overpasses and stream crossings, should be simple, with minimal changes, and with all of the elements in clear relationship with one another. Since many of these bridges are viewed in elevation by those traveling on a roadway below, the structure type, span lengths, and proportions, as viewed in elevation, should be carefully considered.

Bridges that are infrequently viewed, such as those on lightly traveled roadways, are rarely seen by anyone. In these cases, attention to the elements that can be seen from the roadway surface such as parapets, railings, transitions, and road surface, are important.

2.3.3 Horizontal and Vertical Geometry

Geometric design standards often dictate the orientation of a bridge. The emphasis is on the need for safe, convenient driving and providing a more attractive highway system. Bridges must adapt to the highway alignment. Thus, they often lie within the curvature of the road and follow the slopes or curvature in elevation. Large curvature is not only desirable from a safety standpoint, but also for aesthetics.

With skewed structures, when it is necessary to orient the substructure parallel to the feature crossed, a wide bridge presents a greater visual impact. The use of natural surfaces that blend in with the surrounding environment may lessen the visual impact. Bents and end bents in waterways that lie parallel to the river's banks look better than those placed perpendicular to the crossing road.

If an alignment requires a curved bridge, then the external longitudinal lines, traffic barriers, and fascia lines of the structure should follow the curved centerline to provide a smooth visual flow. A smooth transition helps the structure fit in with the local topography. Parallel lines should be maintained by matching barrier, sidewalk, curb and fascia depth across the structure.

2.3.4 Superstructure Type and Shape

The appearance of a bridge is greatly influenced by different aspects of the superstructure. These include the superstructure type, depth, overhang width, number of spans, and span lengths. One way to make the structure light and slender, without making it appear weak and unsafe, is to use a favorable visible slenderness ratio (the ratio of span length to the visible structure depth, including the decking and any concrete traffic barrier or steel railing). The typical visible slenderness ratio will vary from approximately 10 to 40 depending on the type of superstructure chosen.

A girder depth that is too shallow gives the appearance that the bridge is not structurally safe. A girder that is too deep makes the bridge look bulky and overpowering. Bridges with a well-proportioned slenderness ratio denote strength without excessive materials.

An additional guideline that enhances the appearance of multiple spans is to avoid changing girder depths from one span to another. This would give a very awkward appearance and would not allow the structure to flow evenly across the bridge. From an aesthetic standpoint, deck overhang should be proportional to the girder depth; a desirable overhang would be about 2/3 the girder depth. Vertical stiffeners make steel girders seem heavier, and should be avoided on the fascia side of fascia girders. Haunched girders can make a bridge look more slender, and help demonstrate the flow of forces in the bridge. Fishbelly girders create a heavy look, and could tend to look awkward. Some structure types are more visually elegant than others, such as trapezoidal box girders and concrete segmental bridges. An arch bridge is one of the most natural bridge types, and generally considered one of the most pleasing. Both thru and deck arches can be considered.

2.3.5 Bent Shape and Placement

The visual impression that a person gets from a bent is primarily influenced by the proportions, the relative width and height, and the configuration of the bent cap with respect to the bent columns. Bent proportion, in turn, is determined by the bridge geometry and superstructure type and shape. Bents can broadly be classified as either short or tall. Short bents are typically more difficult to design with aesthetic proportions. Care should be taken in proportioning a bent to make sure that horizontal lines of the superstructure are not interrupted. Large bents may direct attention away from the superstructure. Bents that are too slender may convey a feeling of instability.

However, there are aesthetic issues that are common to all bent types involving the shape of the columns and the bent caps. The selection of the proper bent type can be dictated by the site, bridge geometry and design considerations.

The shape and location of the columns affect the appearance of the bents. The light reflecting from the surface often controls how the viewer perceives it. A square or rectangular column with beveled corners will appear more slender due to the edge lines and varying shades of reflected light. The designer needs to assure that the treatments used are in harmony with the rest of the structure. Bent caps, cantilevered ends, and column spacing can be designed to make the bent appear more graceful. For hammerhead bents, the stem width and height, and the cantilever length and depth should be carefully balanced, and in pleasing proportion. Solid bents can be battered to improve their appearance. The batter should be determined by the bent height and the relative dimensions at the top and bottom of the bent. Gradual lines are important. While tall bents are less common than short bents, they allow a greater opportunity for aesthetic treatment.

2.3.6 End Bent Shape and Placement

For most simple span bridges and some multi-span bridges, the end bents are the most visible elements. While the end bent's function is to support the superstructure and transfer loads to the ground, it is

important to maintain proper proportion in order to create a good appearance. Good proportions between various elements of the bridge give character to the bridge. For the end bents it is important to consider the relationships between the exposed end bent height and length, the size and type of wingwalls, and the superstructure depth. An attempt should be made to achieve a balance between these elements.

The designer must maintain order between the lines and edges of the structure. Too many lines, or lines that are close to but not parallel to each other, can disrupt the eye and diminish the appearance of the bridge. The monotony of a large flat wingwall can be broken up using textures such as scoring, recessing, or grooving. Surface textures, either by using or simulating natural stone around the area of the bridge, can be used to integrate the structure with its surroundings.

The orientation of the end bents to the feature crossed will create different visual appearances. End bents on severe skews can have very long stems and wingwalls. Consideration should be given to the aesthetic impact of those concrete surfaces. Wingwalls are often very predominating features. The orientation of the wingwalls allows for more or less visual impact. On divided roadways, the view presented from the opposite direction of travel should be considered.

2.3.7 Parapet and Railing Details

The railings or barriers, along with the deck fascia and fascia girders, are sometimes the most dominant visual aspect of the bridge. The railings are viewed by people traveling under the structure who see them in elevation and by people in vehicles on the bridge traveling parallel to them. When vehicle speeds are high, the railing or barrier should have simple and pronounced details because passengers cannot notice fine details. The shape of the railing or barrier system should relate to its function and the overall aesthetic design of the bridge.

The design and appearance of any fencing to be placed on the bridge should be consistent with the railing or barrier system. The vertical supports of the screening should align with the railing post spacing. Fencing on concrete barriers should be detailed to match the construction joints and the ends of the barriers.

2.3.8 Colors

When there is a reason to color the concrete, steel, or railings, a decision should be made whether the color should complement or contrast with the surrounding environment. Strong consideration should be made to the fact that colored concrete or steel will require a high level of maintenance. The designer should also consider the appearance if regular maintenance is not performed (e.g., peeling paint, rust spots, etc.).

Coloring agents are not allowed in concrete because of complicated quality control, difficulty in matching colors in each batch, and the high cost of materials. It is nearly impossible to get an identical color of concrete from one pour to the next, or over a period of time between placements. Staining concrete can create a mottled appearance when appropriate to match natural stone, and can be effective if a trial section is used to qualify the process. External coatings are allowed, and when applied correctly can achieve the desired appearance. However, they have durability limitations, and must be used with caution due to concern regarding the owner's ability to maintain the coating.

2.3.9 Textures

Texturing concrete can be achieved through form liners, panels, stone or brick veneer, or acid washing. Any texturing should fit in within the overall design and proportions of the structure.

Several types of commercial form liners are available. Natural stone or brick facades can also be used.

Stone is most often used for parkway bridges and those in rural settings. The cost of stone covering can be quite high; and should therefore be limited to areas of high visibility and established contextual settings. When a concrete cap is used on the top of a wingwall or retaining wall, it should be visually proportioned to the wall itself.

2.3.10 Ornamentation

Ornamentation can be added to a bridge in special circumstances. The additional cost of add-ons is rarely justified except in cases of importance to the community (such as a gateway to a city) or of historical significance. Details such as ornamental light posts, columns or pylons, real or simulated gatehouses, commemorative plaques or reliefs may be added. The designer should consider these details carefully since it is just as easy to detract from the overall appearance of the bridge, as it is to improve it.

Such details are secondary to the primary purpose of the structure, which is to provide a safe and efficient crossing to the public. Ornamental and non-structural details require additional coordination, sketches and drawings to ensure that the details will add to the aesthetic characteristics of the structure in a way acceptable to all concerned.

Local stakeholders sometimes request ornamental screening and features on overpass structures to showcase local attractions as a gateway to their community. Ornamental protective screening should not be a distraction to drivers, and must not cause sight distance or clearance problems. Treatments must not reflect a commercial interest. *See BDM 1.13.4* for additional screening requirements.

2.4 BRIDGE TYPES & SELECTION GUIDANCE

[2.4.1 Bridge Types and Economics](#)

[2.4.2 Substructure Guidance](#)

[2.4.3 Special Considerations for Federal-Aid Projects](#)

[2.4.4 Use of Salvage Materials](#)

[2.4.1 Bridge Types and Economics](#)

(1) General

Bridge type is generally the most important factor influencing bridge costs. (Substructure considerations are typically second.) Each project site is unique and should be evaluated for conditions that alter the usual cost expectations. For the following discussion, bridge type generally means classification of superstructure spans by construction material and method of construction.

As can be determined from the Bridge Section’s annual *Structure Cost Data* books, bridge types in order of increasing costs are as follows:

<u>Bridge Type</u>	<u>Span Range</u>
Precast concrete slabs	up to 83 feet
Precast concrete box beams	up to 120 feet
Cast-in-place concrete slabs	up to 50-66-50 feet
Precast integral deck concrete girder	up to 130 feet
Precast concrete girder, BT72	up to 140 feet
Precast concrete girder, BT84	up to 160 feet
Precast concrete girder, BT90 & BT96	up to 183 feet **
Cast-in-place box girder	*
Cast-in-place post-tensioned box girder	*
Steel girder	*
Steel truss	*

*Normally used for longer, multi-span continuous bridges.

** Length for BT90 & 96 is limited by prestressing bed capacity for Oregon precasters.

When using precast or prefabricated girders, verify that there is an acceptable route for shipping. As girder lengths increase, shipping becomes more difficult on roadways with sharp curves, high superelevation and/or load-restricted bridges.

Timber bridges up to 30 feet of length may be considered for special situations (See *BDM 1.8.1*). The cost of a timber bridge may be more than a concrete bridge of the same length.

Do not use cast-in-place concrete slabs with any span greater than 66 feet. Cast-in-place concrete slab superstructures have significant dead load deflections. Even if actual deflections match estimated deflections, it will likely take 10 to 15 years for creep deflection to diminish. For longer span lengths, the ride quality would be unacceptable while waiting for the creep deflection to occur.

Do not use voids in cast-in-place concrete slab superstructures. Although such designs are effective at reducing the structure weight and dead load deflections, it is very difficult to secure the voids in the field. The potential for failure is unacceptably high.

When cast-in-place slabs are used, ensure the edge beam requirements in *LRFD 4.6.2.1.4, 5.14.4.1 and 9.7.1.4* are met.

Where a design deviation is approved by the State Bridge Engineer for use of voids in a cast-in-place concrete slab superstructure, apply the edge beam requirements listed above to this type of bridge.

Use HPC concrete in cast-in-place concrete slab superstructures. Place concrete full-depth of the slab (i.e., no horizontal construction joints). For cast-in-place slab superstructures having any span greater than 40 feet, apply a deck sealer product (from the QPL) at least 60 days after placement of the slab.

(2) Precast Concrete versus Cast-in-Place Concrete

Formwork is the key to concrete structure costs. Use of standard forms or repeated use of specially built forms means lower costs. For smaller bridges in remote areas, precast or shop-fabricated elements usually lead to the most economical solution. Also see *BDM 2.2, Accelerated Bridge Construction*, for more guidance in the use of precast elements.

Precast concrete slabs have the following advantages:

- Good for shorter stream crossings, low-volume roads, and remote locations
- No falsework required in roadway or stream
- Fast, simple installation, saving construction time
- Shallow depth providing greater clearance to stream or roadway surfaces below

However, they have problems with:

- Providing smooth riding surfaces. (AC wearing surface is required to level up except for low-volume roads.)
- Accommodating horizontal curves, gradelines, or superelevations. (Thickness of AC wearing surface to accommodate superelevation can become excessive.)

Precast concrete box beams, girders, and integral Bulb-T beams have most of the same positive and negative points as precast concrete slabs. They can accommodate longer spans, but they do have deeper depths resulting in less clearance to stream or roadway surfaces below.

In general, cast-in-place concrete spans are a good choice for:

- Accommodating horizontal curves, gradelines, or superelevations
- Longer spans

However, three drawbacks are:

- Falsework is required
- Falsework in the roadway below a grade crossing creates traffic hazards
- Settlement of falsework before post-tensioning begins is a potential problem

(3) Continuous Steel Span Bridges

Steel construction extends the span length range and usually does not require falsework in the roadway or stream.

(4) Bridge Widening

Generally, the same type of construction that matches the existing bridge should be used for the widened portion.

(5) Design Criteria for Major or Unusual Bridges

Some elements of design criteria for major and unusual bridges may not be appropriate for normal bridges and may be dependent on the location and expected service level. For those bridges the design criteria will be established specifically for each bridge in a collaborative effort between ODOT Bridge Engineering Section and the Region. Early coordination is required to allow time to establish the design criteria. See *BDM 2.4.3(2)* for further guidance regarding Unusual Bridges.

(6) Maintenance and Provisions for Inspection of Bridges

- Formal constructability and maintainability reviews by representatives of the Construction and Maintenance Sections are required for most bridges to determine the practicality and feasibility of erection/construction of the bridge as assumed in the design as well as adequacy for future maintenance.
- Preparation of an Inspection and Maintenance Guide for the future operation of each major or unusual bridge (see *BDM 3.10.8*).
- Consider designing for the possibility of future bearing replacement. Bearing replacement requires the use of jacks to lift the superstructure off the bearings to be replaced. Indicate the position of these jacks, and allowable jacking loads, on the drawings. Provide distribution reinforcement to accommodate the jack loads in the top of the piers and the soffit of the superstructure. Further, consider the relocation of the reactions in the transverse analysis of the superstructure when the jacks are engaged to replace the existing bearings.
- Bridges fabricated from coated structural steel should be designed for future recoating according to *BDM 1.6.3.4.1*.

2.4.2 Substructure Guidance

See *Section 1.11* for information to guide bent and wingwall layout.

2.4.3 Special Considerations for Federal-Aid Projects

(1) Alternate Designs

According to the Federal Highway Administration (FHWA), the practice of providing alternate designs for major bridges results in substantial savings in bridge construction costs. Current FHWA policy states that use of alternate designs is optional and at the discretion of State highway agencies. If alternate designs are appropriate, consider the following:

- Utilize competitive materials and structural types.

Prepare each alternate design using the same design philosophy. (That is, LRFD design, finite element, etc.) Ensure the design/construction requirements for the entire bridge (foundation, substructure, deck) are compatible.

- Prepare estimates for all Alternate Designs during the TS&L design phase.

Note: Do not confuse this 'Alternate Designs' with the TS&L 'Alternatives Study'. This Alternate Designs is the actual preparation of two or more designs, and plan sheets, to be included in the bid documents.

(2) Unusual Structures

FHWA policy requires "unusual bridges" to be approved (by FHWA) before being designed. An "Unusual bridge" may have:

- Difficult, new or unique foundation elements or problems
- A new or complex design concept involving unique operational or design features
- Design procedures which depart from current acceptable practice

Examples of unusual bridges include:

- Cable-stayed, suspension, arch, segmental concrete, moveable, or truss bridges, and other bridge types which deviate from AASHTO *Design Specifications* or *Guide Specifications*
- Bridges requiring abnormal dynamic analysis for seismic design
- Bridges designed using a three-dimensional computer analysis
- Bridges with span lengths exceeding 500 feet
- Bridges with major supporting elements of ultra-high-strength concrete or steel

Other unusual structures include:

- Tunnels
- Geotechnical structures featuring new or complex wall systems or ground improvement systems
- Hydraulic structures that involve complex stream stability countermeasures
- Designs or design techniques that are atypical or unique

Where unusual bridges are identified, seek FHWA involvement at Project Initiation. Do not advance the design beyond TS&L without FHWA approval.

(3) Experimental Features Program

An experimental feature is a material, process, method, or equipment item that:

- Has not been sufficiently tested under actual service conditions to be accepted without reservation in normal highway construction, or
- Has been accepted, but needs to be compared with acceptable alternatives for determining relative merits and cost effectiveness.

Although the Experimental Features Program is normally used in conjunction with Federal-Aid projects, the program format has occasionally been followed for projects funded entirely with State funds. In some cases, FHWA has paid part of the research cost for basically a State-funded experimental program.

The intent of the Federal-Aid Experimental Features Program is to allow ODOT time to develop, test, and evaluate specifications for new, innovative, or untried products or processes.

(4) Specifying Proprietary Items

To encourage competitive prices from manufacturers and suppliers, FHWA has established a policy for specifying proprietary products or processes for Federal-Aid projects. Generally, “proprietary” means:

- Calling out a product on plans or in specifications by brand name
- Using specifications written around a specific product in such a way as to exclude similar products

The policy basically says:

- You must use two, preferably three, products when specifying by name brand
- You can use generic specifications patterned after a specific item if at least two manufacturers can supply the item

On the other hand, specifying one proprietary item is allowed only:

- If it qualifies for the experimental features program
- If, with written justification from ODOT, FHWA specifically approves in advance a single product, which is essential because of compatibility with an existing system, or the only suitable product that exists

(5) Use of Debris from Demolished Bridges and Overpasses

Public Law 109-59, dated August 10, 2005, Section 1805 mandates that for Federal-Aid bridge replacement and rehabilitation projects, States are “directed to first make the debris from the demolition of such bridge or overpass available for beneficial use by a Federal, State, or Local government, unless such use obstructs navigation.” Links are provided for more information:

- [Public Law 109-59](#) August 10, 2005
- [FHWA Memorandum of March 7, 2006](#)

Note that environmental regulations may prohibit the use of debris in waterways.

2.4.4 Use of Salvage Materials

ODOT Bridge Engineering Section does not prefer the use of used bridge items. New materials are required for new and replacement bridges, and for added portions of widened bridges. Incorporation of used materials requires an approved Design Deviation (see *BDM 1.2.2*). The following are issues to be considered and included in a deviation request.

1. Locate and include in the project records for the new bridge all original material certifications and documentation of material properties.
2. Document the condition of the used materials.
3. Locate and include a copy of applicable portions of the original calculation book in the project records for the new bridge. The copied portions may be scanned and transmitted electronically to the design engineer. Hard copies should be made and included in the calculation book for the new bridge.
4. Prepare a new calculation book for the new bridge.
5. Document agreement from FHWA (on Federal projects) with a Public Interest Finding processed through Roadway Section.
6. Designate on the new plans the portions of the new bridge that are built with salvaged materials.

2.5 BRIDGE LAYOUT

[2.5.1 Site Constraints](#)

[2.5.2 Spans and Proportions](#)

[2.5.3 Bridge Length](#)

[2.5.4 Substructure Guidance](#)

[2.5.1 Site Constraints](#)

At the start of the Preliminary Design Phase, after collecting and reviewing available project data, start identifying site constraints that will impact or affect the bridge layout. Suggested items to discuss with respective project team members (list may not include all applicable items):

- Right of way
- Geology; poor soils
- Known buried hazardous materials
- Waterway; thalweg, potential scour areas
- Floodplains
- Riparian zones
- Wetlands
- Historic resources
- Archeological sites
- Buildings
- Parks
- Air space envelope
- Fluvial envelope
- Railroad envelope

Consider these items early in the bridge layout process. Learning of these constraints later may cause rework that can affect both schedule and budget.

[2.5.2 Spans and Proportions](#)

(1) [Column Locations](#)

Column locations, which of course affect span lengths, are subject to clearance requirements of *BDM 3.14.4.2*, *AASHTO* standard clearances, and hydraulic considerations. After these conditions are met, spans lengths may also be governed by environmental issues, economics and aesthetics. Consider alternate structure types to best fit the needs of the site.

Consider the effects of columns in waterways when locating columns and setting span configurations. Consider the possibility for scour or difficulty in inspecting a column that is in the highest flow area of a river. Avoid placing the column directly in the middle of the river.

Protect columns located in the median of a divided highway and within the clear zone (as determined by the Roadway Designer), from traffic by a guardrail or concrete barrier. Check with the Roadway Designer regarding which barrier will be used. It will affect the bridge's appearance and may influence the type of column selected. Design according to *BDM 1.3.4*.

(2) Structure Depth

Structure depth including deck (also referred to as superstructure depth) is generally controlled by span length and clearance limitations. Although a minimum depth structure may be aesthetically appealing, it may not be the optimal solution for the site.

For steel superstructures, use the minimum depth recommended in *LRFD Table 2.5.2.6.3-1* for estimating purposes. Girder depths for haunched girders made continuous may be reduced up to 20 percent. For haunched girder, use minimum depth of $L/40$ at center of span and $L/20$ at intermediate bent.

For concrete superstructures with continuous spans, use the minimum depths given below:

<u>Reinforced Concrete Superstructures:</u>	<u>Minimum Depth:</u>
Balanced 3-span cast-in-place slabs with main reinforcement parallel to traffic	$d = 0.542 + L/48$
T-Beams	$d = L/19$
Box Girders, constant depth	$d = L/21$

<u>Post Tensioned Box Girders:</u>	<u>Minimum Depth:</u>
Continuous, uniform depth	$d = L/29$

<u>Precast Prestressed Concrete Superstructures:</u>	<u>Minimum Depth:</u>
Slabs and Boxes	$d = L/40$
Deck Bulb-T Girders	$d = L/33$
Bulb-I and Bulb-T girders	$d = L/25$

d = depth of constant depth members or depth at midspan of haunched member.

L = span length between centerlines of bearings for a simple span bridge or longest span between centerlines of bents for a continuous span bridge

Increase depths for simple span bridges by 10 percent.

Depths shown for are for constant-depth sections. Depth at midspan of haunched members may be reduced 15 percent for beams with continuous parabolic haunches or with straight haunches equal to $1/4$ the span where the total depth at the haunch is $1.5d$.

Where minimum depth requirements, given above, are satisfied, the optional live load deflection criteria in *LRFD 2.5.2.6.2* will not be required. When minimum depth requirements are not satisfied, verify that the live load deflection does not exceed the limits recommended in *LRFD 2.5.2.6.2*.

When both minimum depth and live load deflection requirements are not satisfied, submit a request for a design deviation (see *BDM 1.2.2*). As justification for the request, document girder and deck service stress levels, live load deflection, and provide evidence of similar structures already in service with satisfactory performance.

(3) Girder Spacing

Girder spacing is normally dependent on girder capacity. As span length increases, girder spacing should decrease. Limit deck overhangs to no more than one-half the girder spacing. Long deck overhangs tend to sag over time (even decks post-tensioned transversely).

2.5.3 Bridge Length

(1) General

Determine the bridge length by referring to the following as applicable:

- *BDM 1.11.2.1*, “Determining Bridge Length”
- Bridge Standard Drawing *BR115*, “Standard Slope Paving”
- *BDM 3.14.7.2*, “Hydraulic Requirements for Stream Crossings”
- *BDM 3.14.11.3*, “Railroad Clearances”
- *BDM 3.14.8*, (Wildlife passage requirements that may add structure length)
- Following Subsections (2) and (3)

(2) Width and Cross Section of Lower Roadway

For horizontal clearances, see *BDM 3.14.4.2*. Choose the back-slopes as follows:

- Use 2:1 end fill slopes for all bridges unless the Geotechnical designer recommends otherwise.
- 1.5:1 end fill slopes are common for county roads and less-traveled highways. Review the ODOT *Highway Design Manual Figure 4-1*, “Standard Sections for Highways Other Than Freeways”, but do not use a slope steeper than 2:1 unless a steeper slope is recommended in the Geotechnical Report.

(3) Stock Paths at Stream Crossings

Provisions for stock to cross the roadway should be located away from the bridge crossing to reduce concentration of pollutants in the stream. However, if a stock path running under the bridge parallel to the stream is required, additional bridge length will be needed to accommodate:

- Sufficient horizontal space and vertical clearance to construct a benched section for a path above ordinary high water
- A fence to keep stock out of the stream

Stock passes are also discussed in the ODOT *Highway Design Manual*.

2.5.4 Substructure Guidance

Read the *Geotechnical Report* for information and recommendations about type of foundation required, or talk to the Geotechnical Designer if the *Geotechnical Report* is not yet available. For stream crossings, recommendations for scour and riprap protection are contained in the *Hydraulics Report*.

2.6 SAFETY AND ACCESSIBILITY REQUIREMENTS

[2.6.1 Uniform Accessibility Standards](#)

[2.6.2 Inspection and Maintenance Accessibility](#)

[2.6.1 Uniform Accessibility Standards](#)

The Uniform Accessibility Standards are to be used for the design of all Federal-Aid projects.

Design pedestrian overpass and underpass ramps to not exceed a 1:12 grade, and platforms located every 30 feet. Design other features such as handrails and stairs to comply with the standards. Obtain design deviations on a case-by-case basis, if justified.

For pedestrian structures, use FHWA publication *Guidelines for Making Pedestrian Crossing Structures Accessible* (FHWA-I-84-6).

(1) Wingwall and MSE fill slopes

Provide fall protection for wingwall and MSE fill slopes whenever the potential vertical drop exceeds 10 feet. Fall protection may consist of one of the following:

- Roadway barrier at the top of the slope may be considered adequate protection for the public in most cases. However, when the vertical drop at the face of the wall exceeds 15 feet, provide additional protection (safety cable, cable fencing, or chain link fencing) at the top of the wall.
- Safety cable at the top of the wall may be adequate when the slope is not accessible by the public, but access by maintenance personnel or bridge inspectors is anticipated.
- Provide cable fencing when no roadway barrier has been provided at the top of the slope and the slope is accessible to the public. Where a sidewalk is provided at the top of the slope without roadway barrier between the sidewalk and slope, the slope should be considered accessible to the public.
- Provide chain-link fencing or hand railing when pedestrian, maintenance or inspection access is provided adjacent to the top of wall.

Seek concurrence from the Region Safety Manager concerning the specific wall slope protection proposed.

Provide fall protection that is aesthetically appropriate for the site. In many cases, this may involve extending the system along the full length of the wall even though portions of the wall may have less than 10 feet of vertical drop.

(2) Design Criteria for safety cable

Design safety cable and cable fencing using the following criteria:

- Use 1/2" diameter galvanized wire rope with an independent wire rope core and having a minimum breaking strength of 26,000 pounds.
- Use galvanized cable connections and turnbuckles having a minimum ultimate strength at least as great as the cable strength.

- For cable fencing, provide a minimum of two cables with the top cable 36 inches high and the other cables evenly spaced.
- Space cable supports or posts at 10 feet or less.
- Design the cable support system to resist a vertical service load of 3000 pounds (5000 pounds ultimate) anywhere along the length of the cable.
- Design end posts and cable end connections to resist the minimum breaking strength of the cable. End posts for cable fencing need only be designed considering one cable loaded at a time.

2.6.2 Inspection and Maintenance Accessibility

FHWA mandates that bridges be inspected every 24 months. Inspectors are required to access bridge components to within 3' for visual inspection and to access bearings close enough to measure movement. Maintenance personnel need to access damaged members and locations that may collect debris. Be aware of these requirements and prepare designs that allow access for bridge inspectors and maintenance personnel, and possible bearing replacement.

Such facilities should meet the *Oregon Occupational Safety and Health Code Chapter 437 Rules [Division 2, General occupational safety and health Subdivision D, Walking-Working Surfaces](#)*.

For bridge rail height requirements related to inspection and maintenance, see *BDM 1.13.1.11 "Design Standards"* and *BDM 1.13.1.3, "Vehicular Railing"*.

Inspection walks must clear all required minimum clearances under the structure and cannot infringe or reduce minimum required waterway openings.

Provide inspection walks with sufficient headroom and width for inspection personnel to carry bulky equipment between walk rails without difficulty.

Consider inspection walks for wide and high bridges where the reach of the arm of an inspection crane is not long enough for proper inspection and maintenance of the bridge members.

Consider inspection walks combined with other facilities such as ladders, manholes and safety cables. Consider all critical areas that require close inspection such as fracture critical members, hinges, splices, hangers, expansion joints, bearings, utility lines, navigation lights, and areas that require frequent maintenance.

FHWA has recommended maintenance walkways between all steel girders. This has proven to be a costly item and should be reviewed on a case-by-case basis. These were provided on the Santiam River Bridge (Steel Alternate) Bridge 08123D, Drawing 47448. The detailed W5x15 walkway beams are not readily available. A W8x18 alternate is recommended, as this was substituted on the John Day River Bridge, Bridge 00108D.

2.6.2.1 Vertical Abutments and MSE Abutments

Provide access for inspection of bearings and shear lugs. Provide access consisting of the following:

- 3'-0" minimum walkway width - This is the clear width available for an inspector or maintenance worker to walk as needed for inspection and maintenance of bearings, shear lugs and backwalls.

- 4'-0" minimum height - This is the minimum height from the walkway surface to the bottom of girder. For bridges having a solid bottom, such as a concrete box girder, provide 5'-0" minimum.
- Safety Railing or Cable - Provide either safety railing or a safety cable. When a safety cable is used, attach the cable to either the backwall or cap (approximately 4 feet above the top of walkway) or to the bottom of the girders. Note that attachment to precast prestressed girders must be limited to the center 4 inches of the bottom flange. Locate the cable at least 2'-0" horizontal distance away from the vertical drop. Design the safety cable system using the criteria given in *BDM 2.6.1(2)*. Alternatively, standard drawings *BR190* and *BR191* "Horizontal Fall Arrest Lifeline" details are now available. Where potential maintenance activity can be anticipated, such as replacement of bearings, locate the cable to avoid interference with potential bearing replacement and girder jacking operations. Where safety railing is used, design railing to be removable in sections to facilitate maintenance work.
- Access to the walkway - Provide access to the walkway using one of the following:
 - 3'-0" wide walkway along the top of the wingwall. Provide a safety cable or safety railing when the vertical drop exceeds 10 feet.
 - Cast-in-place steel U-bar ladder steps from the ground level (under the bridge) up to the maintenance walkway. In urban environments, place the first U-bar ladder step approximately 12 feet from the ground. Access to this first step will be by portable ladder. Ensure there is an adequate bench for the ladder to seat.
- Security - For bridges in urban environments, use gorilla bar safety railing and provide locked gates at each entrance to the walkway. Design gorilla bar railing to be removable in sections to facilitate maintenance work. See *BDM 2.7.1*, "Bridge Design Security Considerations".

When the height from the ground to the bearings is 15 feet or less, inspection and/or maintenance can be performed with a ladder. If so, ensure there is a 5'-0" minimum bench at the top of slope to support a portable ladder. Where such a bench is not practical, provide cast-in-place steel U-bar ladder steps. Provide enough ladder steps so that an inspector is able to get within 3'-0" of any bearing.

2.6.2.2 Semi-integral and Integral Abutments

Provide access for inspection of bearings and shear lugs. When integral abutments are used, provide access for inspection of backwalls.

The minimum clearance between the bottom of the superstructure and the embankment below shall be 3'-0" for girder bridges and 5'-0" for bridges having a solid bottom, such as a concrete box girder, when bearing access is required. When bearing access is not required, minimum clearance shall be 2'-0".

2.6.2.3 Bridge Superstructures

ODOT policy is to use mobile access equipment for inspection and maintenance work whenever feasible. Fall arrest cable systems are recommended for bridges where access for inspection and maintenance is not feasible using snooper cranes or manlifts.

Provide permanent access to all cells of concrete box girders for utility access, inspections or other purposes. (See *BDM 1.5.7.6*)

2.7 BRIDGE SECURITY DESIGN CONSIDERATIONS

[2.7.1 Bridge Security Design Considerations](#)

[2.7.2 Placing Building Beneath ODOT Bridges](#)

[2.7.1 Bridge Security Design Considerations](#)

2.7.1.1 General

Consider project-specific countermeasures during the Scoping Phase for those structures which ODOT management determines need specific attention.

Potential bridge security threats include: “carried and placed” bombs, vehicle bombs, intentional vehicle or ship collisions, intentional fires, and other intentional and unintentional threatening activities. This section tells when and how to consider potential bridge security threats during the design of:

- New bridges
- Bridge widenings
- Bridge rehabilitation projects

2.7.1.2 Countermeasures

Four countermeasures can help protect structures against potential security threats.

Deter, Deny, Detect, Defend...

Deter: Prevent an aggressor from attacking the structure by making the security presence known such as police or other authorized personnel.

Deny: Prevent an aggressor from entering an unauthorized zone by a physical barrier such as security fencing, secure hatches or locked doors.

Detect: Observe unauthorized personnel in a restricted area by means such as cameras or sensors.

Defend: Provide ‘hardening’ measures to protect a component from attack.

2.7.1.3 Process

Assess the probable structure specific security risks:

- Remote,
- Possible,
- High, or
- Critical

Remote: Only applies to structures on remote, low volume AADT facilities. Implementation of security countermeasures normally not warranted.

Possible: Applies to structures on the non-freeway State Highway System. Consider implementing security countermeasures associated with Deterring and Denying access to the structure. Ideas to consider include:

- Locate box girder soffit access openings away from abutments requiring a ladder or other mechanical means to gain access
- Provide shielded locking mechanisms on all access openings
- Place secure screens at soffit vents near abutments
- Prevent access to maintenance walkways and girder flanges at abutments
- Post warning signs on the bridge approaches and below the structure
- Deny access to critical structural components
- Prevent vandalism, graffiti artists, or ‘homeless condos’

High: Applies to structures on the Interstate Highway System. Consider implementing security countermeasures associated with Deterring, Denying, Detecting, and Defending the structure. In addition to the items listed under ‘Possible’, include the following:

- Establish guidelines for standoff distance
- Eliminate access to small confined spaces

Critical Structures: These are structures that have been determined to be the most vulnerable structures in the State of Oregon.

Some bridges, due to their complex and unique nature, will require project-specific countermeasures along with those countermeasures that apply to all structures. These are bridges considered “critical” to the transportation network. The most critical bridges will also require site-specific operational security plans. The ODOT Emergency Preparedness Committee identified critical bridges and their potential vulnerabilities. To find out more, contact the Statewide Emergency Operations Manager in the ODOT Office of Maintenance and Operations.

Consider the need for security countermeasures during the Scoping Phase to ensure that added costs are included in the project budget. Define countermeasures and security plans and include in the TS&L Report. The Bridge Designer is to consult with the ODOT Bridge Operations & Standards Managing Engineer for security guidance and to maintain consistency statewide.

If the Bridge Operations & Standards Managing Engineer decides a critical bridge needs specific mitigation measures, consider these strategies first:

- Locate piers and towers so vehicular access is prevented.
- Design redundancy with critical elements.
- Place barriers to provide standoff distance when critical structural elements cannot be located away from vehicular traffic. If this cannot be achieved, the critical structural member or mechanical system should be analyzed and hardened against the design threat.
- Install locks, caging, and fencing to deny access to key points of vulnerable structural and mechanical systems.
- Install motion detectors or security cameras, and plan for communications to security response entities, to minimize “time-on-target.”

When cost-effective, consider selective protection of the structural integrity of key members against collapse. Ways to do this include strengthening key substructure members, adding redundancy, and use of blast hardening.

Again, consider project-specific countermeasures during the Scoping Phase for those structures which ODOT management determines need specific attention.

2.7.2 Placing Buildings Beneath ODOT Bridges

The placement of buildings beneath ODOT bridges is strongly discouraged. However, if local public agencies request and are given approval to place buildings below ODOT bridges, satisfy the following requirements:

- Maintain the structural integrity of the bridge:
 - Shore excavations that extend below the bottom of bridge footings adjacent to the proposed building according to Standard Specifications *SP 00510.44*.
 - Replace any soil removed within the vicinity of a bridge footing and compact according to Standard Specifications *SP 00510.46(a)*.
- Bridge maintenance provisions:
 - Provide 10 feet of vertical clearance between roof and superstructure for operation of snooper cranes, or for hanging scaffolds; or
 - Design the building's roof system to act as a work platform for maintenance or construction activities. Provide 3 feet minimum vertical clearance between roof and superstructure. Design the roof sheathing and purlins for a working load of 250 pound point load or 100 psf, whichever controls. Extend the design area 10 feet beyond the shadow of the structure. Design members below the purlin level for a working load of 50 psf over an area of 10' x 20'.
- Future seismic retrofit provisions:
 - Place the building to allow for increasing the size of the existing footing or footings by 50 percent plus an allowance of 5 feet for work area.
 - Make the building owners aware that future footing excavations or pile driving could cause vibrations in the building with a potential for damage to the building or contents. And that the State will not be responsible for any damage to the building or contents caused by such construction.
- Future bridge replacement or widening provisions:
 - Evaluate the need for a new bridge or future widening of the bridge. If the potential exists, allow for increasing the bridge width and construction of new footings. Allow 5 feet around the future footings for work area.
 - Make the building owners aware that future footing excavations or pile driving could cause vibrations in their building with a potential for damage to the building or contents. And that the State will not be responsible for any damage to the building or contents caused by such construction.
- Falling object protection:
 - Place protective fencing on the bridge above the building to cover the limits of any ground activity below the bridge.
 - Make the building owners aware that the State will not be responsible for any damage to the building or content caused by falling objects.

Bridge Design Manual – June 2020
Oregon Department of Transportation
Section 2 – Design Guidance

- Bridge fire protection:
 - The building shall be constructed of non-flammable materials and be equipped with an automatic sprinkler system.
 - The building shall not be used to store large quantities of flammable materials.
- Right of Access:
 - ODOT and or contractor employees shall be given access to the property and/or building as needed to perform any construction or maintenance activities.

Submit proposals to the District Manager and the Bridge Operations & Standards Managing Engineer for review and approval. Include a drawing or drawings showing the existing bridge with all pertinent members dimensioned, and showing the proposed building with all pertinent dimensions, clearances, materials and roof design loads. The drawing or drawings shall be prepared, signed, and stamped with a seal of an engineer registered to practice in the State of Oregon.

2.8 BRIDGE NAME PLATES & MARKERS

[2.8.1 Existing Name Plates](#)

[2.8.2 Bridge ID Markers](#)

[2.8.1 Existing Bridge Name Plates](#)

Specify that existing bridge name plates be salvaged and delivered to the office of the ODOT Construction Project Manager.

[2.8.2 Bridge ID Markers](#)

Specify that bridge identification markers be installed at the bridge site by the construction contractor, unless the Region has an arrangement with District Maintenance to install the markers in-house. Show bridge ID marker placement locations in the bridge contract plans (typically on the Deck Plan, Detail Reference Number 81) and incorporate them into the Special Provisions. Bridge ID markers are not part of the project signing and should not be shown in the sign plans.

Place the ID marker at both ends of the bridge, typically in the bridge rail transition, facing on-coming traffic. If the structure is located over another route, place additional bridge identification markers on the face of the bridge bent, immediately adjacent to and on both sides of the under-crossing roadway, facing on-coming traffic.

For mounting in bridge rail transition areas which have timber posts, the bridge ID marker is attached to a cut off Type-1 steel roadway delineator post. The steel post is attached to a guard rail post as shown in "Type-4, Alternate 2" on Standard Drawing TM570. For mounting in rail transition areas which have steel posts, the ID marker is attached to a full height Type-1 steel delineator post which is driven alongside a transition post. On vertical concrete faces, the ID markers are mounted using stainless drilled mechanical anchors from the QPL. Boilerplate *SP 00842* "Facility Identification Markers" includes these mounting instructions for the contractor.

Configure each ID marker in accordance with the example and information below. Show this information in a table in the bridge plans (see MicroStation cell "T_BridgeID_Marker"). Standard Drawing *BR195* shows dimensions, text, colors and other requirements of the marker for inclusion in the contract plans. For state owned bridges, telephone numbers for the appropriate dispatch can be found at <https://www.oregon.gov/ODOT/Pages/Report-Hazard.aspx>. Note that dispatch center boundaries may not correspond to Region boundaries.

Telephone number of the appropriate agency Dispatch Center
US or OR Route Number
State Highway Number
Milepoint Number
Bridge Number
Name of the Structure

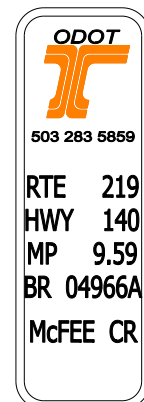

VERSION JUNE 2020

6/1/2020



BRIDGE DESIGN MANUAL

SECTION 3: PROCESSES

BRIDGE ENGINEERING SECTION
OREGON DEPARTMENT OF TRANSPORTATION

Table of Contents

3.1	Section 3 – Introduction	4
3.1.1	Procedure and Process Guides	4
3.2	Bridge Design Software	5
3.2.1	Design Software	5
3.2.2	Software Verification	6
3.2.3	MathCAD Template Library.....	6
3.3	Bridge Design Process (Design-Bid-Build), Overview	7
3.3.1	Scoping.....	7
3.3.2	Project Initiation (Kick-Off).....	8
3.3.3	50% TS&L (Proof of Concept Plans).....	8
3.3.4	TS&L Report.....	8
3.3.5	Design Acceptance Plans Package	9
3.3.6	Preliminary Plans Package Milestone	9
3.3.7	Advance Plans Package Milestone	10
3.3.8	Final Plans Package Milestone	11
3.3.9	PS&E Milestone.....	11
3.3.10	Bridge Design Project Close Out	11
3.4	Roles & Responsibilities	12
3.4.1	Key Personnel	12
3.4.2	Large or Multiple Bridge Projects	15
3.5	Quality	16
3.5.1	Introduction	16
3.5.2	Definitions	17
3.5.3	Design Quality Plans	18
3.5.4	Bridge Design Quality Documentation	19
3.5.5	Bridge Design Quality ‘Touchpoints’	20
3.5.6	Design Reviews.....	20
3.5.7	Design Checks	21
3.5.8	Qualifications of Bridge Designer, Checker & Reviewer.....	23
3.5.9	Performance Measures	23
3.5.10	Troubleshooting Bridge Design Quality	23
3.5.11	Recovery Plans	24
3.5.12	Quality Audits	24
3.5.13	Work Assignments	24
3.5.14	Training & Mentoring.....	24
3.6	(Reserved)	26
3.7	QPL / research	27
3.7.1	Qualified Products List (QPL).....	27
3.7.2	Research	27
3.8	(Reserved)	28
3.9	Preliminary Design / DAP / TS&L	29
3.9.1	Introduction.....	29
3.9.2	Purpose of TS&L	29
3.9.4	TS&L Approval	32
3.9.5	Multiple Bridge Projects.....	32
3.9.6	TS&L Report.....	32
3.9.7	Alternatives Study	32

Bridge Design Manual – June 2020
Oregon Department of Transportation
Section 3 – Processes & Roles

3.9.8	Bridge Design Criteria & Standards Assessment.....	33
3.9.9	Design Deviations and Exceptions.....	33
3.9.10	TS&L Report with Memo.....	33
3.9.11	TS&L Report with Narrative.....	34
3.9.12	Engineer's Estimate @ TS&L.....	34
3.9.13	TS&L Plan Sheet(s).....	34
3.9.14	TS&L Templates.....	35
3.10	Final Design / PS&E.....	36
3.10.1	Introduction.....	36
3.10.2	Sealing & Signing Requirements.....	36
3.10.3	Contract Plans.....	37
3.10.4	Specifications & Special Provisions.....	37
3.10.5	Engineer's Estimate.....	37
3.10.6	Engineer's Estimate of Probable Construction Schedule.....	38
3.10.7	Calculations & Calculation Books.....	38
3.10.8	Bridge Load Rating.....	42
3.10.9	Operations and Maintenance Manuals.....	42
3.11	PS&E to Award.....	43
3.11.1	Introduction.....	43
3.11.2	Changes to Bridge Deliverables after PS&E.....	43
3.11.3	Bridge Design Project Close-Out.....	43
3.11.4	Request for Information (RFI).....	43
3.11.5	Addenda Letters.....	44
3.12	Construction Support.....	45
3.12.1	Introduction.....	45
3.12.2	Communications during Construction.....	45
3.12.3	Shop Drawing Review.....	45
3.12.4	Temporary Works Review.....	45
3.12.5	Construction Support Close-Out.....	45
3.13	(Reserved).....	47
3.14	Coordination with other Project Team Members.....	48
3.14.1	General.....	48
3.14.2	Project Management.....	48
3.14.3	Survey and Mapping, & Right Of Way.....	49
3.14.4	Roadway.....	50
3.14.5	Traffic and Mobility.....	55
3.14.6	Foundations and Geotechnical.....	56
3.14.7	Hydraulics and Scour.....	57
3.14.8	Environmental.....	64
3.14.9	Storm Water.....	67
3.14.10	Utilities.....	68
3.14.11	Railroad.....	69
3.14.12	Public Involvement.....	70
Appendix – Section 3.4 – Roles & Responsibilities.....		71
A3.4.1	Bridge Designer.....	71
A3.4.2	Bridge Reviewer.....	74
A3.4.3	Bridge Design Checker.....	77
A3.4.4	Bridge Subject Matter Expert.....	78
A3.4.5	Bridge Design Coordinator.....	79
A3.4.6	Bridge Quality Auditor.....	80
Appendix – Section 3.5 – Quality.....		81

Bridge EDMS QC Checklist	81
Bridge Drafter QC Checklist for TS&L Plan Sheet(s).....	81
Bridge Drafter QC Checklist for Advance Plans (95%) Plan Sheets	81
<i>Appendix – Section 3.91 – Metric Conversion</i>	<i>82</i>
A3.91.1 Introduction	82
A3.91.2 Basic Units	83
A3.91.3 Derived Units.....	83
A3.91.4 Metric Conversion Factors	85
A3.91.5 Metric Procedural Rules	86
A3.91.6 Bridge Plan and Preparation Guidelines.....	86
A3.91.7 Miscellaneous Common Conversions.....	89

Note: Revisions for June 2020 are marked with yellow highlight. Deleted text is not marked; past editions of the BDM are available for comparison.

3.1 SECTION 3 – INTRODUCTION

BDM Section 3 contains standards and practices pertinent to design procedures and quality processes for completing highway bridge and structure design.

See *BDM Section 1* for standards and practices pertinent to design of highway bridges and structures.

See *BDM Section 2* for design guidance pertinent to highway bridges and structures design.

3.1.1 Procedure and Process Guides

[ODOT Project Delivery Guide](#)

[ODOT Highway Design Manual](#)

3.2 BRIDGE DESIGN SOFTWARE

[3.2.1 Design Software](#)

[3.2.2 Software Verification](#)

[3.2.3 MathCAD Template Library](#)

3.2.1 Design Software

(1) Supported Software

The following programs are used and supported by the Bridge Section:

SOFTWARE NAME	SYSTEM*	USE FOR	QUESTIONS, CONTACT
Midas Civil	7-64	bridge analysis and design	
DFSAP	7-64		
LPile	7-64		
Group	7-64		
ODOT-Col	7-32	column analysis	
PAP	7-64		
FHWA INSTRUCT	Terminal Services		
Brass Girder LRFD	7-64		
Brass Girder STD	7-64		
Brass Library Utility	7-64		
Brass Pole			
PGSuper	7-64	WSDOT precast design program	
PSBeam	7-64		
Response 2000	7-64	Reinforced concrete sectional analysis using Modified Compression Field theory	
SIMON	7-64		
STLBridge LRFD	7-64	steel bridge design using LRFD	
QConBridge	7-64	WSDOT live load analysis program for continuous frames	
RspBr2	7-32		
Convert 4.1	7-64		
Mathcad 15	7-64		
Mathcad Prime	7-64		

* Example: 7-64 indicates the software will run using Windows 7 – 64 bit.

(2) Unsupported Software

With the computer upgrade from Windows XP to Windows 7, most of the bridge legacy programs are out-dated. The following programs are incompatible with the 64-bit systems or will no longer be supported:

- Brig2d (replaced by RspBr2)
- CrkCol
- CrvBrgPc (Midas and GTStrudl have this function)
- DkElev (Microstation can perform this function)
- LdSort
- MStrudl (no longer in business) – Midas and GTStrudl have this function
- ODOT's pole program (uses MStrudl)
- Oregon's PSBeam (not Erikssons PsBeam, which ODOT now uses)
- Ultcol (Xtract can support this function)
- UltFtg (program needed to do simple analysis for footing design (on piling and shallow foundation).
- WinStrudl (no longer in business)
- XSection and WFrame – Caltrans programs
- Drain2dx – dynamic response analysis of inelastic plane structures
- GTStrudl – finite element analysis
- LUSAS
- SAP 2000 – finite element analysis
- SimQuake – DOS – simulation of time, position, and magnitude of earthquakes
- Xtract – CalTrans – substitute for XSection and WFrame

3.2.2 Software Verification

[Reserved for future use]

3.2.3 MathCAD Template Library

The following MathCAD Standard Bridge Rail Calculations are posted on the [Bridge Standards website](#) under the “Software Tools for Design” section. The calculations document the bridge rail design and capacity:

- BR200_Calcs_2016 for *BR200*
- BR206_Calcs_2016 for *BR206*
- BR208_Calcs_2016 for *BR208*
- BR214_Calcs_2014 for *BR214* (will be updated in the near future)
- BR221_Calcs_2016 for *BR221*
- BR290_Calcs_2016 for *BR290*
- (will be updated in the near future)

The spreadsheet “Summary of ODOT Standard Rail Capacities” summarizes all the bridge rail capacities for deck overhang design.

Also available on the [Bridge Intranet](#) are the following Calculation Templates available for ODOT designers use to promote standardization and efficiency.

- Deck Overhang with Concrete Bridge Rail (MathCAD and MathCAD Prime)

3.3 BRIDGE DESIGN PROCESS (DESIGN-BID-BUILD), OVERVIEW

[3.3.1 Scoping](#)

[3.3.2 Project Initiation \(Kick-Off\)](#)

[3.3.3 50% TS&L \(Proof of Concept Plans\)](#)

[3.3.4 TS&L Report](#)

[3.3.5 Design Acceptance Plans Package](#)

[3.3.6 Preliminary Plans Package Milestone](#)

[3.3.7 Advance Plans Package Milestone](#)

[3.3.8 Final Plans Package Milestone](#)

[3.3.9 PS&E Milestone](#)

[3.3.10 Bridge Design Project Close-Out](#)

3.3.1 Scoping

The Project (by others) – Scoping involves a reconnaissance level look at one or more alternatives for a project. It involves more planning, conceptual design, and description than the project-level design performed after STIP programming. This level of planning assists in securing funding and determining ‘Level of Effort’ required by various work units. Site constraints are identified; assumed or known design exceptions or deviations are noted; and anticipated outsourcing of work is noted.

Bridge Design – Potential Bridge Program projects are initiated by the Bridge Program Unit from queries run on the State’s Bridge Data. A ‘Desk Scope’ is completed, and an [ODOT Project Business Case](#) is drafted by the Bridge Program Manager. This information is then sent to the Region for ‘Field Scoping’. After the Region Scoping Team has performed the ‘Field Scope’, it is sent back to the Bridge Program Unit for review and reconciliation, and the Bridge program Manager updates the ODOT Project Business Case. The final ODOT Project Business Case is provided to a Project Leader by a Region Area Manager after STIP programming, and eventually Project Initiation. Also see [Highway Division Directive DES 01](#).

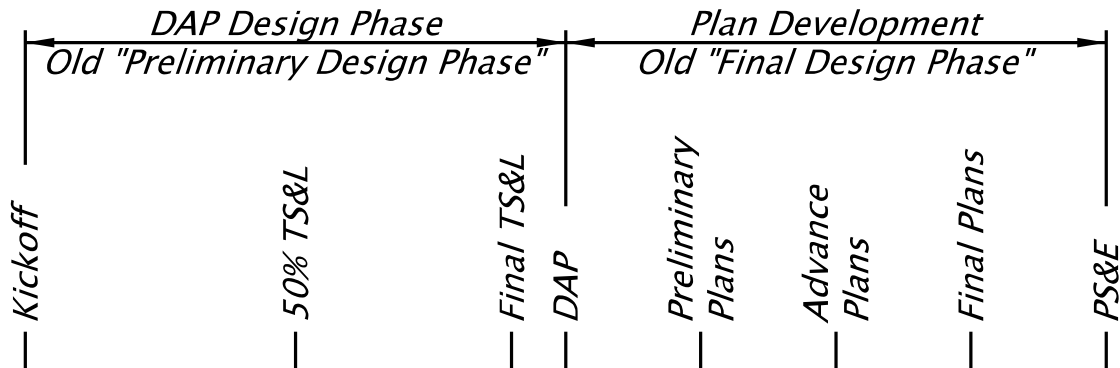

3.3.2 Project Initiation (Kick-Off)

The Project (by others) – Project Initiation is when the project is ‘kicked off’ by the Project Leader. Final refinements to the scope, schedule and budget occur at the Project Kick-Off meeting.

Bridge Design – The Bridge Reviewer meets with the Bridge Designer a couple weeks prior to the Project’s Kick-Off meeting to prepare by reviewing the Bridge Design Work Order (for outsourced work also see the statement of work of A&E contract), schedule and budget, project charters, the project’s scope and the ODOT Project Business Case (if available). The Bridge portion of the Region Quality Control Plan is also reviewed at this time, and supplemented to cover any project specific needs. Also see [PDLT Operational Notice PD-02](#).

Verify the proposed bridge/structures scope of the project design as well as begin development of design deviations and exceptions. Bridge designers use available scoping information and draft project charters to prepare the Bridge Design Criteria and Standards Assessment. Confirm completion of load rating, deck testing and certain preliminary analyses of existing bridges that will be not be replaced. Ensure results are appropriately reflected in the draft project charter and other work description documents.

The Bridge Designer and Reviewer complete the appropriate Bridge QC Checklist found in [BDM A3.5](#). A list of responsibilities at this milestone for the Bridge Reviewer and Designer can be found in [BDM A3.4](#).

3.3.3 50% TS&L (Proof of Concept Plans)

The Project (by others) – Concept Plans consists of enough detail to “proof” the project concept that has been put forth. Site constraints are identified, and alignments are close to final. Consider permanent and temporary traffic control, and note specialty specification items. Include as many bid items as can be identified in cost estimates.

Other work completed by others at this stage include: survey control established, survey topography gathered, survey base map produced, existing right of way determined, environmental base map produced, Area of Potential Impact (API) identified, draft utility conflicts identified, horizontal and vertical alignments calculated, bridge bent locations set, retaining wall locations set.

Bridge Design – The Alternatives Study and a rough draft of the TS&L Narrative (or Memo) are complete and ready to review by the Bridge Reviewer. Review and update the Bridge Design Criteria and the Bridge Design Standards Assessment and create a list of design deviations and exceptions for each alternative. Structural analysis calculations may need to be started and sufficiently advanced so can meet Preliminary Plans milestone needs. Include “significant cost” bid items on the Engineer’s Estimate @ TS&L. A draft TS&L Plan Sheet may be prepared to include with the other project Concept Plans. Coordinate need with the Project Team.

The Bridge Designer and Reviewer complete the appropriate Bridge QC Checklist found in [BDM A3.5](#). A list of responsibilities at this milestone for the Bridge Reviewer and Designer can be found in [BDM A3.4](#).

3.3.4 TS&L Report

The Project (by others) – Is nearing the Design Acceptance Plans (DAP) milestone.

Bridge Design – The TS&L Report (consisting of the Alternatives Study, TS&L Memo or Narrative, TS&L Plan Sheets, Engineer’s Estimate, Standards Assessment, and Design Deviations/Exceptions) is complete, has been reviewed and approved by the Bridge Reviewer, and is ready to publish in the DAP. Submit TS&L Report to the Project Leader.

Provide bridge deliverables to the appropriate personnel to complete a Construction Review, Maintenance Review and Regional Bridge Lead Engineer Review (see *BDM 3.5.6.4*). Schedule a review meeting with Construction and Maintenance personnel to discuss comments. The Bridge Designer, Reviewer and Drafter complete the appropriate Bridge QC Checklist found in *BDM A3.5*. A list of responsibilities at this milestone for the Bridge Reviewer and Designer can be found in *BDM A3.4*.

3.3.5 Design Acceptance Plans Package

The Project (by others) – Design Acceptance Plans (DAP) provide sufficient detail of project elements and staging to identify right of way and utility impacts, utility relocation needs, and to allow application for permits. Complete staging except for minor details.

At this milestone, alignments are final and the project ‘footprint’ is set. Changes after this stage should be seldom needed, and work after this stage is adding detail and refining the design. Each project team member is to review others’ DAP deliverables to ensure the work is compatible between disciplines, and there are no discrepancies.

Roadway often takes the lead on common products, such as distributing the DAP and compiling a complete cost estimate. A Design Narrative may be prepared that incorporates all sections’ commentaries. Reference may be made to other complete documents, such as the Bridge TS&L Report, providing only minimal data in the Design Narrative for such sections.

Some items to be completed by others at or near the DAP milestone include:

- Roadway: Approved Design Exceptions, Project Narrative, DAP Cost Estimate
- Geotechnical: Preliminary Geotechnical recommendations documented
- Hydraulics: Hydraulic recommendations and plans

Bridge Design – Respond to any needs identified by the Project Leader. Attend the Design Acceptance Workshop (DAW), if scheduled.

Some items to be completed at or near the DAP milestone include:

- Bridge: TS&L Report (including Alternative Study), Approved Design Deviations and Exceptions, Information for permits
- Start structural analysis calculations and Preliminary contract plans.
- Write specialty specs with enough detail to give reviewers an idea of the work and pay items involved. Include most of the bid items in cost estimates, although quantities will not be accurately calculated at this time.

A list of responsibilities at this milestone for the Bridge Reviewer and Designer can be found in *BDM A3.4*.

3.3.6 Preliminary Plans Package Milestone

The Project (by others) – Preliminary Plans incorporate adjustments that are needed due to further refinement with right of way, utility, and permitting negotiations that have occurred. Decisions affecting the footprint of the project are made by this time. Each project team member is to review others’ Preliminary Plans deliverables to ensure the work is compatible between disciplines, and there are no discrepancies.

Some items to be completed by others at the Preliminary Plans milestone include:

- Roadway: Preliminary Plans, Bid Summary/Cost Estimate
- Geotechnical: Draft Geotechnical Report

Bridge Design Manual – June 2020
Oregon Department of Transportation
Section 3 – Processes & Roles

- Hydraulics: Draft Hydraulics Report, Storm Water Management Plan
- Environmental: Obtaining permits is continuing during this phase
- Utilities: Work with utility companies to establish utility relocations

Bridge Design – Substantially complete structural calculations and prepare Preliminary contract plans. All plan sheets are started and prepared to approximately 70% complete, showing the basic geometry of all major elements. Identify boilerplate special provisions using SPLIST. When there is no boilerplate special provision, provide a draft special provision. Complete the Engineer's Estimate @ Preliminary Plans including all bid items with rough calculated quantities. Provide bridge deliverables to the Project Leader for inclusion in the Preliminary Plans review package.

Provide bridge deliverables to the appropriate personnel to complete a Construction Review, Maintenance Review and State Bridge Engineer Review (see *BDM 3.5.6.4*). Schedule a review meeting with Construction and Maintenance personnel to discuss comments.

Some items to be completed at the Preliminary Plans milestone include:

- Preliminary Plans, Engineer's Estimate, List of anticipated special provisions
- All plan sheets are started and included in the review package.
- Engineer's Estimate is to include all bid items with rough calculated quantities.
- Include boilerplate special provisions (i.e., compilation of boilerplate special provisions straight from the ODOT webpage; without "refining" work).

The Bridge Designer and Reviewer complete the appropriate Bridge QC Checklist found in *BDM A3.5*. A list of responsibilities at this milestone for the Bridge Reviewer and Designer can be found in *BDM A3.4*.

3.3.7 Advance Plans Package Milestone

The Project (by others) – Advance Plans include all items necessary to bid and build the project. Each project team member is to review others' Advance Plans deliverables to ensure the work is compatible between disciplines; and review the entire plan set for clarity and consistency.

Some items to be completed by others at the Advance Plans milestone include:

- Roadway: Advance Plans, Construction Cost Estimate, Special Provisions,
- Construction: Construction Schedule
- Geotechnical: Stamped Geotechnical Report
- Hydraulics: Stamped Hydraulics Report, stamped Storm Water Management Plan
- Environmental: Obtaining permits may be continuing during this phase

Bridge Design – Complete structural analysis calculations and prepare Advance contract plans. Prepare plan sheets to approximately 95% complete (only lacking corrections based on QC Checking comments), including all geometry and details necessary for bidding and construction. Complete draft special provisions, including specialty special provisions, and Engineer's Estimate @ Advance Plans, including a complete itemized list of bid items and accurately calculated quantities. Complete the Engineer's Estimate of Probable Construction Schedule when required by project team. Provide bridge deliverables to the Project Leader for inclusion in the Advance Plans review package; to the Bridge Checker for detailed structural QC check.

Some items to be completed at the Advance Plans milestone include:

- Advance Plans, Engineer's Estimate, Special Provisions

The Bridge Designer, Reviewer, Checker and Drafter complete the appropriate Bridge QC Checklist found in *BDM A3.5*. A list of responsibilities at this milestone for the Bridge Reviewer, Designer, and Checker can be found in *BDM A3.4*.

3.3.8 Final Plans Package Milestone

The Project (by others) – Final Plans consist of digitally signing the plan sheets and preparing for submittal of the design work and finalizing the PS&E package.

Some items complete at the Final Plans milestone include:

- Roadway: Final Plans, Construction Cost Estimate, Final Special Provisions
- Construction: Final Construction Schedule
- Environmental: Approved permits

Bridge Design – Address comments from the detailed structural QC check and other reviews. Finalize structural analysis calculations and prepare Final contract plans. Complete plan sheets (100%). Complete final special provisions, final Engineer’s Estimate of Probable Construction Schedule when required by project team, and Engineer’s Estimate @ Final Plans. Provide bridge deliverables to the Project Leader for inclusion in the Final Plans package. Also see [PDLT Operational Notice PD-02](#) and [Final PS&E Submittal Checklist](#), and ensure the Bridge-related aspects of these documents are complete.

Some items to be completed at the Advance Plans milestone include:

- Final Plans, Engineer’s Estimate and Final Special Provisions

The Bridge Designer, Reviewer and Checker complete the appropriate Bridge QC Checklist found in [BDM A3.5](#). A list of responsibilities at this milestone for the Bridge Reviewer, Designer and Checker can be found in [BDM A3.4](#).

3.3.9 PS&E Milestone

The Project (by others) – At PS&E all the contract documents prepared by the Project Team are submitted to the Office of Project Letting by the Project Leader to begin the process of advertising and bid letting.

Bridge Design – Complete the structural analysis Bridge Designer and Checker calculation book(s). Make a pdf of the calculation book(s) and submit to the Bridge Reviewer. Assist the Project Leader to address any PS&E Package deficiencies before advertising; and to address any RFIs and Addendum Letters during advertising. Prepare the “design” bridge load rating.

The Bridge Designer, Reviewer and Checker complete the appropriate Bridge QC Checklist found in [BDM A3.5](#). A list of responsibilities at this milestone for the Bridge Reviewer, Designer and Checker can be found in [BDM A3.4](#).

3.3.10 Bridge Design Project Close Out

Bridge Design – Within 60 days after Award, complete ‘Bridge Design Close-Out’ documents, per [BDM 3.11.3](#).

3.4 ROLES & RESPONSIBILITIES

[3.4.1 Key Personnel](#)

[3.4.2 Large or Multiple Bridge Projects](#)

[3.4.1 Key Personnel](#)

The following is a list of 'key' roles and responsibilities related to the design of a bridge. This is not an exhaustive list of responsibilities and duties for the position noted. This list is intended to supplement the ODOT [Project Delivery Guide](#) (PDG), not supersede it. Also see [PDLT Operational Notice PD-01](#).

State Bridge Engineer

- The role of the State Bridge Engineer is to provide management and leadership to the State's Bridge Engineering Section.
- The State Bridge Engineer is responsible for:
 - Overseeing the Bridge Program.
 - Overseeing the Bridge Operations and Standards Unit.
 - Overseeing the Bridge Preservation Design Unit.
 - Overseeing the Regional Bridge Design Unit.

Bridge Program Manager

- The role of the Bridge Program Manager is to provide management and leadership to the State's Bridge Program Unit.
- The Bridge Program Manager is responsible for:
 - Developing and programming the Bridge Program STIP.
 - Approving final scope of work for Bridge Program projects.
 - Approving changes to and funding for Bridge Program projects.

Bridge Operations and Standards Manager

- The role of the Bridge Operations and Standards Manager is to provide management and leadership to the State's Bridge Operations and Standards Unit.
- The Bridge Operations and Standards Manager is responsible for:
 - Providing Subject Matter Experts for Bridge Designers and Drafters to consult with during the development of projects.
 - Maintaining the Bridge Design Quality Program, and providing Quality Auditors to audit bridge designs.
 - Maintaining the Bridge Design Manual and Bridge CAD Manual.
 - Maintaining the Bridge Standard Drawings and Details.
 - Modifying existing or developing new standards for design.
 - Providing technical training to bridge designers and drafters.

Bridge Design Manager

- The role of the Bridge Design Manager is to provide management and leadership to the State's Regional Bridge Design Unit.
- The Bridge Design Manager is responsible for:
 - Satisfying the staffing needs of the various bridge and structural analysis needs by providing the appropriate resources.
 - Developing and implementing strategies to ensure the sustainability of the bridge design technical discipline statewide.

Regional Bridge Lead Engineer

- The role of the Regional Bridge Lead Engineer is to represent the Bridge Design Manager in the regions.
- The Regional Bridge Lead Engineer is responsible for:
 - Performing lead engineer duties associated with the Regional Bridge Design Unit.

Bridge Reviewer

- The role of the Bridge Reviewer is to perform the QC/QA design review from prior to Project Initiation through Project Award.
- The Bridge Reviewer is responsible for:
 - Checking in with, and mentoring, the Bridge Designer and Checker at key points in time to ensure work is progressing in a satisfactory manner to meet or beat schedule and budget.
 - Reviewing work and deliverables prepared by the Bridge Designer and Checker.

Bridge Designer

- The role of the Bridge Designer is to provide structural analysis and design for the Agency's maintenance and other structural design related needs.
- The Bridge Designer is responsible for:
 - Performing structural analysis and design for bridges and other highway related structures.

Bridge Design Checker

- The role of the Bridge Design Checker is to perform the QC bridge design check of the structural analysis and design for bridges and other highway related structures.
- The Bridge Design Checker is responsible for:
 - Performing the QC bridge design check of the structural analysis and design for bridges and other highway related structures.

Bridge Design Project Lead

- The role of the Bridge Design Project Lead is to lead and coordinate the bridge design on projects with multiple bridge designers or bridges.
- The Bridge Design Project Lead is responsible for:
 - Coordinating design, estimating and specification writing among the bridge designers on the bridge project design team.
 - Reviewing developing bridge designs to ensure consistency is maintained between bridge designs.
 - Attending Project Team meetings and representing the bridge project design team.

ODOT Project Leader

- The role of the Project Leader is facilitating and coordinating project teams.
- The Project Leader is responsible for:
 - Scope, schedule and budget for projects developed using ODOT staff.

Bridge Design Manual – June 2020
Oregon Department of Transportation
Section 3 – Processes & Roles

A&E Project Manager

- The role of the A&E Project Manager is facilitating and coordinating project teams.
- The A&E Project Manager is responsible for:
 - Scope, schedule, budget, and quality of contracted projects/work.

Local Agency Liaisons

- The role of the Local Agency Liaison is to manage project development for local government projects.
- The Local Agency Liaison is responsible for:
 - Delivery of local government projects, including local bridge projects.

Region Tech Center Manager

- The role of the Region Tech Center Manager is to provide management and leadership to the Region Tech Center.
- The Region Tech Center Manager is responsible for:
 - Managing technical staff assigned to the Region involved in project development.
 - Developing and implementing a design quality control program within the Region Tech Center.
 - Ensuring project work is consistent with the Region Quality Plan.
 - Monitoring quality assurance performance.

Consultant Project Manager (CPM)

- The role of the Consultant Project Manager is to serve as project leader in the delivering of entire projects using full-service consulting contracts.
- The Consultant Project Manager is responsible for:
 - Coordinating with consultants for delivery of full-service outsourced projects.
 - Scope, schedule and budget for projects developed using outsourced staff.

Project Managers

- The role of the Project Manager is to administer contracts for construction.
- The Project Manager is responsible for:
 - Construction management for in-house and outsourced projects.

Area Manager

- The role of the Area Manager is to oversee the complete project lifecycle including: scoping, preliminary engineering, and construction phases of work.
- The Area Manager is responsible for:
 - The delivery of projects in their area.

A&E Bridge Design Consultant

- May be contracted to perform the design duties associated with the Bridge Project Lead, Senior Bridge Engineer, Bridge Engineer, Bridge Designer, Bridge Design Reviewer, or Bridge Design Checker for individual projects or “program” of projects.
- Should not be contracted to perform “Owner” duties of the State Bridge Engineer, Bridge Program Manager, Bridge Operations and Standards & Practices Manager, Bridge Design Manager, or Bridge Design Leadworker.

3.4.2 Large or Multiple Bridge Projects

Large design projects with multiple or complex structures usually involve several Designers and Drafters. Often, these large projects can be done more efficiently if a Lead Designer and Lead Drafter organize and manage the bridge design and drafting.

The following are guidelines for the Bridge Design Team Lead Designer. (*BCM* discusses guidelines for the Lead Drafter.) Before the project kick-off the Lead Designer and Drafter should review these guidelines and meet with the Bridge Reviewer to discuss the project and these duties.

Project Initiation (Kick-Off) – The Lead Designer should:

- Communicate to project team members and other ODOT units as well as outside organizations that he or she will be the bridge design contact person for the project
- Obtain available design information

Preliminary and Final Design Phases – The Lead Designer should monitor design and drafting work, which includes:

- Attend Project Team meetings
- Be aware of the status of design and drafting in relation to lead-time required to meet submittal deadlines and bid-opening dates (Request help as needed to meet deadlines.)
- Maintain project records and update the project team by keeping:
 - A file of correspondence and decisions that affect design
 - Project team members informed, by memos or meetings, of any decisions or changes
 - Design Reviewer aware of project status and any changes that develop
- Be available to project team members, especially new designers, and encourage them to ask questions and share some of their assumptions for design and analysis before they start on a major modeling and design task
- Coordinate preparation of Bridge deliverables
- Review Bridge Plans for uniformity of design/drafting practices and detailing
- Review Bridge deliverables for completeness before submittal to Design Reviewer
- Stay informed about what is happening with all project bridges in order to answer questions from others in the absence of other bridge design team members

3.5 QUALITY¹

[3.5.1 Introduction](#)

[3.5.2 Definitions](#)

[3.5.3 Design Quality Plans](#)

[3.5.4 Bridge Design Quality Documents](#)

[3.5.5 Design Quality 'Touch Points'](#)

[3.5.6 Design Reviews](#)

[3.5.7 Design Checks](#)

[3.5.8 Qualifications of Bridge Designer, Checker & Reviewer](#)

[3.5.9 Performance Measures](#)

[3.5.10 Troubleshooting Quality Issues](#)

[3.5.11 Recovery Plans](#)

[3.5.12 Quality Audits](#)

[3.5.13 Work Assignments](#)

[3.5.14 Training & Mentoring](#)

[3.5.1 Introduction](#)

Quality Control and Quality Assurance is based on:

- Quality is achieved by adequate planning, coordination, supervision, and technical direction.
- Quality is achieved by focusing on preventing problems or errors rather than reacting to them.
- Quality is verified through monitoring, checking, and reviewing work activities, with documentation by experienced, qualified individuals who are not directly responsible for performing the work.
- Quality should ensure that the work is done correctly the first time. (Appropriate knowledge and experience levels, appropriate design team, appropriate project management, appropriate communication of project scope, appropriate communications, appropriate attention at the appropriate time by members of the project team.)

The owner plays the most important role in the quality and success of a project from design through construction. This applies to in-house design and consultant design as well as design-build design. The owner must clearly establish the requirements and expectations of a project through RFP design documents, contract plans, and other design or construction related documents. These requirements and expectations must be communicated and understood by the designer and the construction contractor. The owner, the designer, and contractor are then expected to work together to meet the requirements and expectations.

A Quality Control / Quality Assurance (QC/QA) program establishes the formal office or organizational

¹ FHWA, Guidance on QC/QA in Bridge Design In Response to NTSB Recommendation (H-08-17), August 2011

procedures or practices for ensuring the owners requirements and expectations are fully met. A QC/QA program provides checks and balances within an organization to assure quality in the final contract plans and specifications. QC/QA programs are implemented at different levels or phases of project activities. QC/QA is more than performing a design check and review to the design calculations and contract plans. Design QC/QA starts at Project Initiation and is an ongoing process through Project Award and Construction.

Overall Project QC/QA will be planned and carried out primarily by the Tech Center Manager, Project Leader or Project Manager. The process, however, involves every member of the project team, and others, such as: Region Tech Center Manager, Project Leader (PL), Project Manager (APM), Region Area Manager, Bridge Checker, Bridge Reviewer, State Bridge Engineer, Bridge Program Manager, Bridge Operations & Standards Manager, Senior Bridge Engineer, Bridge Subject Matter Experts, ODOT Structural Materials Engineer, ODOT Construction Engineer, ODOT Maintenance Engineer, and the ODOT Office of Project Letting Quality Engineers.

In the bridge design phase, the bridge designer is responsible for making sure his/her calculations and drawings are accurate and meeting the requirements of the design. The bridge designer performs QC of his/her own work by establishing procedure for self-checking the work for accuracy and correctness. The checker performs QC of the designer's calculations, plans, specification, and estimates. The reviewer, practicing QA, is responsible for ensuring the established quality procedures and practices are completed, and reviewing the work of the bridge designer and bridge checker to assure accuracy and correctness in meeting the design requirements and expectations of the bridge owner.

3.5.2 Definitions

Quality: The degree to which a product or service meets or exceeds a customer's requirements and expectations.

Quality Management: The overall management function that determines quality policy, objectives, and responsibilities, and their implementation by means such as quality planning, quality assurance, quality control, and quality improvement within the system.

Quality Control (QC): In general: the operational activities put in place to control the quality of a product or service. These include such activities as providing clear decisions and directions, diligent supervision by experienced individuals, immediate review of completed activities for accuracy and completeness, and accurate documentation of all decisions, assumptions, and recommendations. Quality control procedures, if followed, should ensure that the work is done correctly the first time.

As it relates to bridge design – checking design criteria, procedures of checking the accuracy of the calculations and consistency of the drawings, detecting and correcting design omissions and errors before the bridge design plans are finalized, and verifying the specifications for the load-carrying members are adequate for the service and operation loads.

Quality Assurance (QA): The certainty that products and services meet the requirements for quality. The objective of quality assurance is the continual improvement of the total delivery process to enhance quality, productivity, and customer satisfaction. Essentially, quality assurance describes the process of enforcing quality control standards. When quality assurance is well-implemented, progressive improvement in terms of both reducing errors and omissions and increasing product usability and performance should be observed. Quality assurance should function as a "voice" for the customer, a reminder that the work product is intended for use by a customer. (Essentially, QA is what the project manager does to confirm that a QC program is effective and provides feedback upon which further development of the QC program can be made.)

As it relates to bridge design; making work assignments, overseeing the establishment of design criteria, procedures of reviewing the work to ensure the quality control are in place and effective in preventing mistakes, and consistency in the development of bridge design plans and specifications.

Quality Control Plan: The comprehensive, well-defined, written set of procedures and activities aimed at delivering products that meet or exceed a customer's expectations, as expressed in contract documents and other published sources. A quality control plan will identify the organization or individuals responsible for quality control and the specific procedures used to ensure delivery of a quality product. A quality control plan will also detail quality assurance measures and the method of accountability and required documentation.

Bridge Designer: An individual directly responsible for the development of design calculations, drawings, specifications, and contract documents, and review of shop drawings related to a specific bridge design with a level of technical skills and experience commensurate with the complexity of the subject structure or structures being designed.

Bridge Checker: An individual responsible for performing a full technical check of the structural design calculations, drawings, specifications and contract documents.

Bridge Reviewer: An individual responsible for performing QA procedures for assuring that QC procedures have been performed.

Engineer of Record: An individual responsible for all bridge structural aspects of the design of the structure including the design of all of the bridge's systems and components. The Engineer of Record normally seals and signs the final contract plans and specifications.

3.5.3 Design Quality Plans

ODOT Bridge Section – As it relates to bridge design, ODOT Bridge Section maintains the baseline QC/QA procedures in the BDM that form the basis for the Bridge Design Quality Control Plan.

ODOT Regions – Each Region has a Design Quality Control Plan that provides guidance to technical staff on the preparation of high quality, cost effective, deliverables that meet the expectations of its customers.

A&E Consultants – All design consultants shall have a documented Design Quality Plan (DQP) for the firm's design. This applies to the Prime Consultant and any and all of their subconsultants. In lieu of subconsultants having their own documented DQP, the Prime Consultant should assume that responsibility for their subconsultants. The DQP should be furnished to ODOT as a Start-Up deliverable in the design contract, and as requested. ODOT should review the DQP to ensure it meets the intent of the Agency's Quality Program(s), and refer to it when reviewing consultant work deliverables.

Local Agency Quality Control Plan – See Local Agency Guidelines (LAG) manual

3.5.4 Bridge Design Quality Documentation

3.5.4.1 For Typical STIP Projects

The following is a list of the Bridge documents to retain, preferably in Agency's ProjectWise system. If the project is not in ProjectWise, then in a folder on the Bridge Section server in which the data can be accessed for Quality Auditing purposes. Electronic pdf files are preferred in lieu of paper hardcopies. For internal designs, submit these documents to the Bridge Design Manager (who will send to the Bridge Design Coordinator for tracking and document retention purposes). For external designs, the Design Contractor will submit these documents to the ODOT Project Manager identified in the contract. The ODOT PM will send the documents to the assigned Bridge Reviewer (or the Regional Bridge Lead Engineer if there is no assigned Bridge Reviewer); and the Bridge Reviewer who will send the documents to the Bridge Design Manager.

1. ODOT Bridge Design Work Order (for internal designs; refer to the A&E Contract for external designs), original and any revisions
2. A&E Personal Services Contract, if applicable (for external designs)
3. Project Startup deliverables
4. TS&L Report (reviewed and final copy(s))
5. Preliminary Plans Package (reviewed and final copy(s))
6. Advance Plans Package (reviewed and final copy(s))
7. Final Plans Package (reviewed and final copy(s))
8. Calculation Book(s)
 - a. Note: Unless a separate calculation book is necessary, put TS&L calculations in the Final Design calculation book.
 - b. Final Design calculations, Designer's calculations
 - c. Final Design Check calculations, Checker's calculations
9. Checker Review Comment Forms
 - a. Review Comments, Responses, and QC Verification
10. Reviewer Review Comment Forms
 - a. Review Comments, Responses, and QC Verification
11. Bridge Designer, Bridge Checker, and Bridge Reviewer QC/QA Checklist

Note 1: The supporting Hydraulics and Geotechnical Reports are retained in the ODOT Geo-Environmental Section.

Note 2: See the [BPPM](#) for the Bridge Design Coordinator role and responsibilities, details regarding storage/retainage of the Bridge Quality Documents (where they are stored, how long they are stored), and how they may be accessed.

3.5.4.2 For Bridge Maintenance Projects

The following is a list of the Bridge documents to retain in a folder on the Bridge Section server in which the data can be accessed for Quality Auditing purposes. Electronic pdf files are preferred in lieu of paper hardcopies.

1. ODOT Bridge Design Work Order, if available, original and any revisions
2. Project Startup deliverables
3. Options Memo (reviewed and final copy(s)) when required
4. Checking Package (reviewed and final copy(s))
5. Final Plans Package (reviewed and final copy(s))
6. Calculation Book(s)
 - a. Final Design calculations, Designer's calculations
7. Checker & Reviewer Review Comment Forms
 - a. Review Comments, Responses, and QC Verification

3.5.5 Bridge Design Quality ‘Touchpoints’

Internal designs will typically have the following QC/QA ‘Touch Points’:

- Project Scoping – Review comments, Draft BDWO
- Project Initiation – Scope confirmation, BDWO finalized (for start of design), and Bridge Reviewer, Designer, & Checker assignments
- Start-Up – Design Criteria, Standards Assessment, and Design Deviation/Exception identification review comments
- 50% TS&L (by schedule) – progress check-in
- TS&L Report – Review comments, signature sheet signed
- DAP/DAW – Review comments
- Preliminary Plans Package
- Advance Plans Package – Review comments
- Final Plans Package – Comment resolution verification
- PS&E Package – Bridge design quality documentation
- Project Quality Audit
- Project Close-out

External designs should have similar QC/QA ‘Touch Points’. See the consultant’s Design Quality Plan for specifics.

3.5.6 Design Reviews

3.5.6.1 Bridge Reviewer

- Responsible for performing role as noted in *BDM 3.4.1*, *BDM A3.4.2* and per Bridge Reviewer QC/QA Checklist.
- Responsible for performing QA procedures or seeing that QC/QA procedures have been performed.
- May request Subject Matter Expert review (not a check), including welding, protective systems, and bridge inspection
- May request Structural Materials Review
- May request Region Bridge Inspector for bridge inspection features
- Ensures that Construction Review has been performed
- Ensures that Maintenance Review has been performed

3.5.6.2 Peer Reviews

For major projects involving unusual, complex, and innovative features, a peer review may be desirable to raise the level of confidence in the quality of design and construction. A peer review is generally a high-level QA review by a special panel of professionals specifically appointed by the State Bridge Engineer or designee to meet the demands for quality and accuracy, recognizing the complexity of the design. Peer review is an effective way to improve quality and to reduce the risk of errors and omissions. The need for such peer reviews is at the discretion of the State Bridge Engineer.

3.5.6.3 Project Leader / Project Manager Review²

- Responsible for coordinating and leading reviews and quality processes.
- Leads Project Team Review, including a review by individual team members to coordinate design items between disciplines.

² ODOT Quality Program also calls this a “Peer Review”. However, this subsection has intentionally not been included as a second bullet to *BDM 3.5.6.2* because industry peer review is typically understood to mean people of the same background – in this case, all with a background of bridge design.

3.5.6.4 Regional Bridge Lead Engineer / Bridge Design Manager Review

A design review will be performed by the following personnel:

- Regional Bridge Lead Engineer
- Bridge Design Manager, on selected projects
- Regional Bridge Lead Engineer may request Bridge Engineering Section Review (Subject Matter Expert review (not a check), including welding, protective systems), however, the outcome of this review is typically advisory comments or recommendations.

External designs are subject to the same Regional Bridge Lead Engineer design review. The design consultant will submit TS&L Report to the A&E Project Manager for distribution.

3.5.7 Design Checks

The expected Class of Check is noted on the Bridge Design Work Order. An assessment of the expected Class of Check will be made based on the table below. In some cases, based on geometry for example, the entire bridge may require “Independent” check calculation. In other cases, based on elements, the bridge may require “Independent” check calculations for specific elements, and “Line-by-Line” checks of the Designer’s calculations for the remainder of the bridge. This will be noted on Bridge Design Work Order based on the best information available prior to the Project’s Kick-Off meeting. The Bridge Designer and the Bridge Reviewer should review the Bridge Design Work Order before checking starts to ensure the Class of Check is appropriate. Changes to the expected Class of Check must be approved by the Regional Bridge Lead Engineer before proceeding with the check. Changes to the Class of Check require the Bridge Design Work Order be revised (for Quality documentation purposes). Revise the Bridge Design Work Order with a ‘pen-and-ink’ note to show the new Class of Check and the Regional Bridge Lead Engineer’s initials.

Design checks fall into one of the following Classes of Checks:

Class I:

- Prepare “Independent” structural calculations
- Check plans, specifications, and estimate

Class II:

- Perform “Line-by-Line” check of Bridge Designer’s structural calculations
- Check plans, specifications, and estimate

Class III:

- No structural calculations
- Quantity calculations
- Check plans, specifications, and estimate

Use Class III check procedures for bridge preservation work except for calculations in support of seismic retrofit, strengthening, or structural changes.

An “Independent” check means the Checker will prepare his or her own calculations without or before seeing the Designer’s calculations. After the Checker has prepared his or her calculations the Checker and Designer compare results. Generally this type of check takes longer than a “Line-by-Line”. The advantage is two separate sets of calculations are made; disadvantages include: tendency for the Designer not to complete his or her design calculation book, content can become cryptic, abbreviated, and difficult to follow.

Bridge Design Manual – June 2020
Oregon Department of Transportation
Section 3 – Processes & Roles

A “Line-by-Line” check means the Checker will work from a copy of the Designer’s calculations, going through line-by-line and redlining. Besides checking line by line, the Checker must also ask “Has the Designer included all calculations required?” Generally there is a time savings in performing this type of check. Other benefits of this type of checking include: calculation book is complete (for design purposes) at PS&E, and junior designers can see senior designers work, content is complete and understandable (especially worthwhile if have to make revisions during construction after several months of not working on the design).

To perform a “Line-by-Line” check the Checker obtains a copy of the Designer’s calculations. The Checker should review the Table of Contents to ensure it is in order, complete, and that all expected entries are included. The Checker should then review the Givens and the Assumptions. Then the Checker can go through the calculations line by line. Any comments should be redlined. Redlining can be done by hand with a red pencil, or electronically in a pdf file. If checking comments are not made electronically in the copy, the hardcopies should be scanned to pdf and saved in appropriate electronic folder.

Use the following table to determine if a “Line-by-Line” check is acceptable, or if an “Independent” check is required:

	Check Calculations	
	“Line-by-Line”	“Independent”
Geometry / Layout	Regular; Tangent; Simple-Span	Irregular; Curved ¹ ; Skewed ² ; Multi-Span
Standard Drawings / Details	Acceptable	If judged necessary
Major / Unusual / Complex	Not acceptable	Acceptable
Seismic Design / Retrofit ³	Design Categories A & B	Design Categories C & D
Prestress Slabs ⁴	Must have successfully completed 2 prior designs	< 2 prior designs
Prestress Boxes ⁴	Must have successfully completed 2 prior designs	< 2 prior designs
Prestress Tubs ⁴	Must have successfully completed 2 prior designs	< 2 prior designs
Prestress Girders ⁴	Must have successfully completed 2 prior designs	< 2 prior designs
Post-Tension anything	Not acceptable	Acceptable
Steel Plate Girder	Must have successfully completed 2 prior designs	< 2 prior designs
Steel Trapezoidal Girder	Must have successfully completed 2 prior designs	< 2 prior designs
Abutments	Regular; Non-Integral	Integral & Semi-Integral
Columns	Not acceptable	Acceptable
Bridge Strengthening	Must have successfully completed 2 similar designs	< 2 prior designs
Rail Retrofits	Must have successfully completed 2 similar designs	< 2 prior designs
Footnotes:		
<ol style="list-style-type: none"> 1. Curvatures with Radius < 1000 feet 2. Skew > 20 degrees 3. Includes Capacity Protection design 4. ODOT Standard shapes only; otherwise do “Independent” calculations 		
Notes:		
<ul style="list-style-type: none"> • The items in the table were agreed to between the Bridge Section Operations and Standards Managing Engineer and FHWA Bridge Representative. No changes or deviations from this table should be made without discussing with both of these people. 		

- If the bridge or bridge element you are checking is not described in this table then prepare “Independent” calculations.
- Any check starting as “Line-by-Line” can be escalated to “Independent” calculations with approval of the Bridge Reviewer. No check starting as “Independent” calculations may be reduced to “Line-by-Line”.
- To request a deviation from the practice noted in this table see *BDM 1.2.2*
- To suggest an addition to this table that you believe is a good candidate for “Line-by-Line” checking please send an email to the Bridge Design Standards and Practices Engineer.

3.5.8 Qualifications of Bridge Designer, Checker & Reviewer

The bridge designers, checkers, and reviewers are the key personnel to provide well-designed and constructible plans to build good quality bridges. The bridge designers, checkers, and reviewers must be experienced in structural designs and familiar with the current AASHTO Bridge Design and Construction Specifications and the State’s Bridge Design Manual (BDM).

- 1) **Bridge Designer and Checker:** The following are the desirable requirements for a bridge designer and checker:
 - Possess a Professional License as a Civil Engineer or Structural Engineer in Oregon; or
 - If the bridge designer and checker do not have a PE/SE license, he or she should be under the direct supervision of a PE/SE licensed engineer who is in responsible charge of the design;
 - The bridge designer and checker’s experience should be commensurate with the complexity of the bridge being designed.
- 2) **Bridge Reviewer:** The bridge reviewer should be familiar with Bridge Engineering Section’s standards and practices, and ODOT’s project delivery and construction practices, procedures, and policies.

3.5.9 Performance Measures

Performance Measures are specific items/tasks to monitor to ensure the successful completion of something (e.g., a goal, a specific piece of work, a change in process, a person’s assigned duties, etc.). The manager typically establishes these items to align with his/her responsibilities (e.g., Goals and Objectives, specific charges, etc.). These items can be for an individual or for a group; however, they should be assessed on an individual basis. These items typically become the basis of an individual’s performance assessment/appraisal.

3.5.10 Troubleshooting Bridge Design Quality

This is not troubleshooting ‘design delivery’; this is what to do if Bridge Design Quality is not being met.

- Early intervention.
- Discussion/Review by Bridge Design Manager, Region Tech Center Manager, Bridge Reviewer, and Bridge Operations and Standards Manager.
- Review of approved design team by Bridge Design Manager.
- Review BDWO (internal designs; A&E contract SOW and QP for external designs) for changes (actual and/or under-estimated) as it relates to needed knowledge/experience.
- Change resource’s assignments before making resource reassignment.
- Provide training, internal or external, if schedule allows
- Provide coaching/mentoring of resource, if schedule allows.

3.5.11 Recovery Plans

The purpose of a recovery plan is to document specific tasks that need to be done, with dates the tasks need to be done, to get back on schedule or back in budget (i.e., revised performance measures). After “troubleshooting” any bridge design Quality issues, the Bridge Design Manager will prepare a brief narrative plan documenting these tasks/measures; keeping a copy and providing a copy to the Bridge Designer and the Bridge Reviewer.

3.5.12 Quality Audits

The following is a brief outline of the Quality Audit process that will be performed by the Quality Auditor on a random sample of projects (see BPPM, Quality Auditor, for specifics):

- On a regular schedule, randomly select projects to perform quality audit
- Notifies Bridge Design Manager (who will notify Regional Bridge Lead Engineer), Bridge Reviewer, and Bridge Designer
- Review BDM and Region Design Quality Plan(s)
- Review Bridge Design Work Order
- Audit project Bridge Quality Documentation retained in ProjectWise or the appropriate location of the Bridge server
- Collect Reviewer QC/QA Checklist
- If complete, prepare Audit Report noting findings
- If not complete, contact the Bridge Reviewer and Bridge Designer and discuss discrepancies
- If necessary, contact the Bridge Design Manager and requests data be completed and submitted
- Once data received, complete Audit Report
- Provide Audit Report to State Bridge Engineer, Bridge Design Manager, and Bridge Operations and Standards Manager

3.5.13 Work Assignments

- Performed by the Bridge Design Manager.
- For internal, done based on knowledge, skills and abilities, and training needs.
- For external, done through RFP process and consultant selection (based on consultant proposal (i.e., response to RFP).)
- For Local Agencies, typically done through RFP process. Some Counties still eligible for Free Bridge Design through ODOT.

3.5.14 Training & Mentoring

Bridge Design Manager:

- Oversees the Resource Planning group with assignment of project Bridge Reviewer, Designer, and Checker.
- Evaluates and identifies skill gaps.
- Suggest or recommend training courses to be delivered by Subject Matter Experts.
- Trains people involved in Bridge QCQA what documents need to be retained for Quality purposes.

Reviewer:

- Mentors Designers: Throughout course of reviewing a project (from Project Initiation to PS&E Package), the Reviewer is mentoring the project designer (rookie & veteran); and quite possibly training the rookie designer.
- Mentors Checkers: If during the course of reviewing a project, the Reviewer may elect to mentor the design checker.

Bridge Design Manual – June 2020
Oregon Department of Transportation
Section 3 – Processes & Roles

- Mentors Reviewers: Veteran Reviewers will mentor and train new or less experienced rookie Reviewers.
- Trains people involved in Bridge QCQA what documents need to be retained for Quality purposes.

Subject Matter Expert:

- Provides training in subject of expertise as needed (training may be one-on-one, one-on-many, external provider, etc.)

Training Coordinator (proposed):

- Maintains database of internal bridge design staff, their project assignments, their role on the project (Reviewer, Designer, or Checker), a short description of the project, and a short description of the bridge work performed.
- Provides report of this information as requested.

3.6 (RESERVED)

3.7 QPL / RESEARCH

[3.7.1 QPL](#)

[3.7.2 Research](#)

[3.7.1 Qualified Products List \(QPL\)](#)

The Structure Services Unit of the Construction Section is responsible for the evaluation of products for use on construction and maintenance projects.

If a product is approved for use, it is included in the [Qualified Products List](#) (QPL) published every six months. The QPL is covered in [Section 00160.05](#) of the ODOT *Standard Specifications for Highway Construction* as modified by the special provisions. The special provisions of a project will tell which edition of the QPL is in effect for that contract.

A product can be evaluated as an “equal product” or a “new product”:

- Equal products are similar to ones currently used by ODOT and are covered by existing specifications or standards.
- New Products are ones not addressed by current specifications or standards.

After evaluation, a product’s status becomes one of the following:

- Conditional – Equal or new product will be allowed a trial installation on one project only, recommended for a demonstration project, or recommended as an experimental feature. See [Section 3.17.3\(3\)](#) “Experimental Features Program”.
- Qualified – Product is equal to existing approved products or has test results that meet ODOT specifications.
- Rejected - Product does not meet ODOT specifications or has failed performance testing.

Products with Conditional status will have trial installation on projects where they can be monitored during installation and for a limited performance period. The manufacturer or supplier is responsible for locating an active project, either construction or maintenance, for the proposed product. Normally, a product will be considered Conditional first, and then move to Qualified after it establishes a good track record. Of course, a previously qualified product can fall from grace and become rejected because of unsatisfactory field performance.

[3.7.2 Research](#)

(Reserved for future use)

3.8 (RESERVED)

3.9 PRELIMINARY DESIGN / DAP / TS&L

[3.9.1 Introduction](#)

[3.9.2 Purpose of TS&L](#)

[3.9.3 When is a TS&L needed?](#)

[3.9.4 TS&L Approval](#)

[3.9.5 Multiple Bridge Projects](#)

[3.9.6 TS&L Report](#)

[3.9.7 Alternatives Study](#)

[3.9.8 Bridge Design Criteria & Standards Assessment](#)

[3.9.9 Design Deviations and Exceptions](#)

[3.9.10 TS&L Report with Memo](#)

[3.9.11 TS&L Report with Narrative](#)

[3.9.12 Engineer's Estimate @ TS&L](#)

[3.9.13 TS&L Plan Sheet\(s\)](#)

[3.9.14 TS&L Calculations](#)

3.9.1 Introduction

DAP Design Phase (aka, old “Preliminary Design Phase) is the phase between the milestones Project Initiation (Kickoff) and Design Acceptance Package (DAP). The DAP Design Phase concludes with the acceptance of the DAP (or cancelation of the project). When the project includes bridge structures the DAP will typically include a section for Bridges and will include one or more TS&L Reports or Bridge/Structures DAP reports (i.e., “modified” TS&L Reports).

The TS&L Report is prepared to provide the opportunity for the State Bridge Engineer and the Bridge Design Manager to have input on the type of bridge, or work affecting the bridge, under design. Items to be addressed include: type, size and location of the bridge; use of high performance materials; use of new technologies; new innovative materials; opportunities for accelerated construction; unique/creative new uses of known materials; constructability; appropriateness of construction techniques; maintainability; inspectability; cost-effectiveness; aesthetic requirements; corrosion protection strategy; improved details to eliminate existing problem areas on bridges (i.e., bridge expansion joints, fatigue prone details, bearings, etc.); hydraulic/scour analysis and deck drainage; geotechnical requirements and types of foundations.

Preliminary design studies should consider the bridge location, length, width, span arrangement and superstructure system considering traffic requirements, safety measures, channel configuration, stream flow, etc. Feasible alternatives for a proposed bridge crossing along with their merits and shortcomings, should be identified and discussed.

3.9.2 Purpose of TS&L

The purpose of a TS&L Report is to:

Bridge Design Manual – June 2020
Oregon Department of Transportation
Section 3 – Processes & Roles

- Document the Alternatives Study or reasonable alternatives/options considered;
- Document the recommended alternative (or option), and the “approved” alternative advanced to the Final Design Phase (aka, PS&E Phase) (in some situations these can be different);
- Document the rationale (i.e., the justification) for “why” the recommended and ‘approved’ alternative(s) or option(s) was(were) selected over the other alternatives or options;
- Document the selected type, geometry, size, and location of the recommended and ‘approved’ alternative or option;
- Document deviations from design practices; and
- Provide rationale with background information for reviewers, owners, or clients to effectively evaluate and approve an alternative to advance to final design.

Provide just enough information to address each discussion item as a bridge designer; typically it is not necessary or desirable to provide the supporting information used by other disciplines (i.e., biologists, hazmat specialists, roadway engineers, traffic engineers, historians, etc.).

Commentary:

There may be a misconception that the TS&L Report is prepared so that the Bridge Hydraulics Report, Geotechnical Subsurface Exploration, and Preliminary Geotechnical Reports can be prepared. In actuality, each of these documents should be prepared at the same time with each document preparer working in close coordination and collaboration with the other document preparers.

A TS&L Report provides specific bridge information required by FHWA for their review and approval of projects using Federal funding (and recommended for projects without Federal funds). It is the concluding documentation of the Alternatives Study. The name was coined by FHWA circa 1990. The acronym TS&L stands for Type, Size & Location. The FHWA/ODOT Stewardship Agreement of the Federal Aid Program has delegated the TS&L review and approval process to ODOT for federal-aid projects that are designated as NOT Full Federal Oversight (FFO). ODOT will submit TS&L Reports to the FHWA on projects designated as FFO.

Note: If adequate background information is NOT provided the TS&L may be rejected, which could result in an undesirable delay in the project schedule.

Bridge Engineering Section makes a distinction between the TS&L and the DAP. The TS&L is used as the approval document for the bridge discipline. The DAP is the approval document for the entire project. The duties of the Bridge Reviewer include official approval of the TS&L for the bridge discipline. Although Bridge Engineering Section is provided the opportunity to review the TS&L, the outcome of this review is typically advisory comments or recommendations.

The DAP submittal provides ODOT the opportunity to officially “approve” a project concept. However, since it includes the entire project, review of this submittal is typically directed more towards roadway layout with very little attention on structures. For this reason, the primary Quality Control requirements for the bridge discipline are focused on the TS&L.

To ensure a sincere review of the TS&L, adequate time in the schedule is necessary to allow modifications to the design and revisions of the TS&L prior to submittal of the DAP. A minimum of two weeks should be allowed for small projects. Large projects will require additional time. This time between TS&L and DAP is critical to the Quality Control process. When time is not provided, quality is compromised since rejection of the TS&L would, in many cases, result in an unacceptable delay to the project. Where project schedules are compressed, increased involvement by the Bridge Reviewer in the early stages of design can mitigate project delay risk.

3.9.3 When is a TS&L needed?

A TS&L Report is required when:

- Typically, anytime work other than routine maintenance or emergency repair is performed on a bridge, or
- Whenever work is on primary longitudinal (e.g., girders) or transverse (e.g., crossbeams) load carrying elements.

When is it necessary to prepare a TS&L Narrative:

- Anytime an Alternatives Study is performed, or
- Whenever it is necessary to prepare structural calculations for the work.

When is it acceptable to prepare a TS&L Memo in lieu of a TS&L Narrative:

- Whenever work is on elements other than the primary longitudinal or transverse load carrying elements, or
- Whenever it is not necessary to prepare structural calculations for the work.
- Whenever the work primarily consists of bridge preservation.

Commentary:

An Alternative Analysis is typically a comparison of credible alternatives such as “new concrete bridge in location A, new steel bridge in location B, culvert/fill in location C, etc.

A comparison of options analyzes options such as “patch concrete with passive anodes, patch concrete with impressed current cathodic protection, patch concrete and coat with silane sealer, etc.

If an Alternatives Study of the primary longitudinal or transverse load carrying elements, or structural calculations is not necessary then a TS&L Memo may be prepared to:

- 1) document the nature of the work at the end of the DAP Design Phase and before starting the Plan Development Phase, and*
- 2) document the rationale for selecting between options for non-primary longitudinal or transverse load carrying elements.*
- 3) document the rationale for selecting bridge preservation options. Typical examples of bridge preservation work include bridge painting, cathodic protection, concrete patching for historic preservation or to preserve a bridge for economic reasons, ornamental “stealth” rail replacement, movable bridge work, and covered bridge work.*

If the scope of work at the end of the DAP Design Phase is the same as the scope of work at the beginning of the DAP Design Phase the TS&L Memo will simply document that the scope is the same. If the scope of work at the end of the DAP Design Phase has changed, the TS&L Memo should document the reasons why the scope has changed. For Bridge Program bridge projects, it is very important to have the concurrence of the Bridge Program Manager and the State Bridge Engineer before proceeding to Final Design. This is the primary reason for the TS&L Memo.

3.9.4 TS&L Approval

Under the direction of the Bridge Design Manager, the Bridge Reviewer will review and approve the TS&L Report. The TS&L Report will be signed by both the Bridge Designer and the Bridge Reviewer. The Bridge Reviewer's signature will constitute "approval" of the TS&L by a person knowledgeable in bridge design.

Commentary:

Prior to 2004 the ODOT Bridge Design Team Leader (Structural Manager) and the State Bridge Engineer "approved" the TS&L. After 2004, the Region Bridge Manager and, by virtue of the 'project development process', the Region Tech Center Manager and Area Manager formally "approved" the TS&L via their signature of the DAP Report.

3.9.5 Multiple Bridge Projects

For projects with more than one bridge structure, create a separate section/chapter within the same TS&L Report for each bridge structure. Creating a separate section/chapter for each bridge will:

- 1) make it easier to add or subtract bridges, should the scope change;
- 2) make it easier to focus discussions on individual bridges; and
- 3) make it easier to not have to flip through pages of information for other bridges that are not relevant to the particular bridge.

3.9.6 TS&L Report

TS&L Report is comprised of:

- TS&L Narrative or TS&L Memo
- Engineer's Estimate @ TS&L
- TS&L Plan Sheet(s)
- Bridge Design Criteria & Standards Assessment
- Design Deviations and Exceptions
- Alternatives Study supporting data

Tables and figures are an integral part of a well-written TS&L Report. If the text is crowded with detail, especially quantitative detail, consider creating a table. Do not overload the text with information that could be presented better in a table. Tables are often used for reporting extensive numerical data in an organized manner.

3.9.7 Alternatives Study

Perform the Alternatives Study investigating at least three bridge types; considering such things as site/corridor context, site access, environmental factors, material availability, constructability, construction contractor knowledge/experience, and cost. Include this study in the design calculation book.

When the project involves an existing bridge, use the alternatives study to consider reasonable alternatives that may include replacement, preservation or rehabilitation, and status quo (do nothing), on the basis of first cost and life-cycle cost. The alternative with the lowest life-cycle cost will provide the highest overall value to the Agency, but cash flow considerations sometimes dictate selection based on lowest first cost.

3.9.8 Bridge Design Criteria & Standards Assessment

At the start of the DAP Design Phase prepare the bridge design criteria and a table of bridge standards applicable to the design. Include references to Standard Drawings, Standard Details, BDM references, AASHTO Design Code references, etc. and standard values; include actual design values; and include notation whether the actual design values meet or do not meet that standard. This table will become the basis for preparation of design deviations and exceptions. Include this table in the design calculation book.

[Note: A template is in the works to aid in this assessment.]

3.9.9 Design Deviations and Exceptions

Whenever the actual design values do not meet a standard value prepare a design deviation or exception. See *BDM 1.2.2*. Include approved deviations and exceptions in the design calculation book.

3.9.10 TS&L Report with Memo

1. Cover Page
2. Signature Page
3. Table of Contents
4. Body of Memo
 - a. Project Information
 - b. Rationale for selections between options
 - c. Rationale for changes in scope
5. Engineer's Estimate @ TS&L
6. TS&L Plan Sheet(s)
7. Appendix
 - a. Bridge Design Criteria & Standards Assessment
 - b. Approved Design Deviations and Exceptions

For most projects that include “bridge preservation” work, in addition to project information, rationale for selection, and rationale for scope changes, the TS&L Memo will address the following items if applicable:

1. Historic preservation requirements / ADA Compliance
2. Park land impacts
3. Deck condition and chloride content
4. Staging of the work
5. Load rating status (i.e., should the bridge be strengthened as part of the project, and can the bridge support any needed work access or other temporary works?)
6. Items from the list in *BDM 3.9.11(4)*:
 - a. Mobility
 - b. Environmental Information & Constraints
 - c. Utilities
 - d. Railroad
 - e. Any other item listed that affects the preservation work

3.9.11 TS&L Report with Narrative

1. Cover Page
2. Signature Page
3. Table of Contents
4. Body of Narrative, preferred alternative
 - a. Project Information (location)
 - b. Alternatives Studied
 - c. Recommended Alternative
 - d. Bridge Design Criteria
 - e. ADA Compliance
 - f. Mobility (AADT, # lanes to remain open, detours)
 - g. Roadway (horizontal & vertical alignment, superelevation, roadway x-section)
 - h. Hydraulics (design flood, ordinary high water, scour)
 - i. Geotechnical & Foundations (subsurface conditions)
 - j. Environmental Information & Constraints
 - k. Traffic (signs, signals, illumination)
 - l. Utilities (on bridge, near bridge)
 - m. Railroad (clearances)
 - n. Right of Way
 - o. Superstructure (type, geometry, length, width, clearances)
 - p. Substructure (type, geometry, size, clearances)
 - q. Aesthetics
 - r. Other Design Justification (if rationale for decisions made is not provided above)
5. Engineer's Estimate @ TS&L, preferred alternative
6. TS&L Plan Sheet(s), preferred alternative
7. Appendix
 - a. Bridge Design Criteria & Standards Assessment
 - b. Approved Design Deviations and Exceptions
 - c. Plan sheets of all other alternatives, as needed

Note 1: If the *Hydraulics Report* or *Geotechnical Report* is not available at the time the TS&L Narrative is written, always include comments about assumptions made in consultation with the Hydraulics or Geotechnical Designer.

Note 2: Do not use the TS&L Narrative to provide all the data needed for environmental permitting. Include this permitting information in a separate memo. See *BDM 3.14.8* for further guidance.

3.9.12 Engineer's Estimate @ TS&L

The Engineer's Estimate @ TS&L documents the estimated construction cost of the preferred alternative. Prepare an estimate for each alternative studied. The estimate typically is based on a rough calculation of quantities. Include estimate in TS&L Report.

3.9.13 TS&L Plan Sheet(s)

The TS&L Plan & Elevation Drawing is a single 11x17 sheet containing:

- Title Block
- Vicinity Map (with north arrow)
- Plan View (with north arrow)
- Elevation View
- Typical Section
- Construction Staging Section(s)

- Hydraulic Data (if applicable)
- TS&L General Notes

A second sheet (or more) may be included to show construction staging typical sections, if significant/applicable.

See *Bridge CAD Manual* for specific information pertaining to the drafting and detailing of the TS&L Plan & Elevation drawing.

Include plan sheets in the TS&L Report.

3.9.14 TS&L Templates

The following TS&L templates are posted on the [ODOT Bridge website](#):

[TS&L Memo \(Template\)](#)

[TS&L Narrative for Bridge Replacement \(Template\)](#)

[TS&L Narrative for Bridge Strengthening \(Template\)](#)

[TS&L Narrative for Phase 1 Seismic Retrofit \(Template\)](#)

3.10 FINAL DESIGN / PS&E

[3.10.1 Introduction](#)

[3.10.2 Sealing & Signing Requirements](#)

[3.10.3 Contract Plans](#)

[3.10.4 Specifications & Special Provisions](#)

[3.10.5 Engineer's Estimate](#)

[3.10.6 Engineer's Estimate of Probable Construction Schedule](#)

[3.10.7 Calculations & Calculation Books](#)

[3.10.8 Bridge Load Rating](#)

[3.10.9 Operations & Maintenance Manuals](#)

3.10.1 Introduction

The Final Design Phase can begin after receiving approval of the DAP. For Design-Bid-Build projects, the Contract Documents are prepared during the Final Design Phase. These documents include sealed and signed construction plan sheets, Special Provisions, Engineer's Estimate, and estimates of probable construction schedule. Other bridge deliverables prepared during the Final Design Phase include calculation books, the bridge load rating, and Operation and Maintenance manuals.

3.10.2 Sealing & Signing Requirements

[ORS 672.002\(10\)](#) requires the stamping engineer to be in 'responsible charge'; that is, to have supervision and control of the work.

- The Bridge Engineer of Record is to seal and sign the final Mylar Bridge drawings; other roles noted on the drawing may be signed or printed. Current practice requires only one stamp on the plans. (Refer to [TSB11-02D](#))
- The Bridge Engineer of Record or the Bridge Designer is to seal and sign other applicable work products per [TSB11-02D](#). (ODOT Intranet link: [DES 05-02](#))
- The Bridge Checker is to seal and sign structural calculations he or she prepares.

It is expected that a person possessing a professional engineer's license in the State of Oregon will seal and sign his or her own work.

See ODOT Technical Services [Professional of Record Guidance](#) for further guidance.

3.10.3 Contract Plans

3.10.3.1 At Preliminary Plans

Start all plan sheets and show gross geometry of the elements. Start details if have information; however, it is not necessary to have all details shown at this time.

3.10.3.2 At Advance Plans

Complete “unchecked” plan sheets. All geometry and details are to be shown at this time. Prepare Check Print set of plan sheets for the Bridge Checker and the Bridge Reviewer.

3.10.3.3 At Final Plans

Correct plan sheets based on resolution of QC Check comments. Prepare mylar plan sheets for signatures.

3.10.3.4 At PS&E Package

Clear and complete detailed plans with information necessary to obtain a fair bid and to layout and construct the project.

3.10.4 Specifications & Special Provisions

3.10.4.1 At Preliminary Plans

Download SPLIST from the ODOT Special Provisions webpage and complete the checklist. A benefit of using SPLIST is the reference Special Provisions are also noted.

3.10.4.2 At Advance Plans

Complete a draft of the Special Provision package.

3.10.4.3 At Final Plans > Final Special Provisions

Complete the final Special Provision package.

3.10.4.4 At PS&E Package

Specifications, Supplemental Specifications, and Special Provisions necessary for construction of the project.

3.10.5 Engineer’s Estimate

3.10.5.1 At Preliminary Plans

Calculated quantities of materials in the project, based upon the current Bid Item list.

3.10.5.2 At Advance Plans

Calculated quantities of materials in the project, based upon the current Bid Item list.

3.10.5.3 At Final Plans

Calculated quantities of materials in the project, based upon the current Bid Item list.

3.10.5.4 At PS&E Package

Calculated quantities of materials in the project, based upon the current Bid Item list. Estimate of the cost of design assistance during construction.

3.10.6 Engineer's Estimate of Probable Construction Schedule

A Project Construction Schedule is required to be submitted with the PS&E Package per 4.2.i of the [Phase Gate Delivery Manual](#).

3.10.6.1 At Preliminary Plans

Not applicable.

3.10.6.2 At Advance Plans

Refer to the [Phase Gate Delivery Manual](#), and prepare and submit a draft of the estimated probable construction schedule for the bridge or structure construction for review [when required by the project team](#).

3.10.6.3 At Final Plans

Update the estimated schedule, and submit a final copy [when required by the project team](#).

3.10.6.4 At PS&E Package

Not applicable. (A complete Project Construction Schedule, including the bridge and structure work will be submitted to the Office of Project Letting by the Project Leader or Project Manager.)

3.10.7 Calculations & Calculation Books

3.10.7.1 Types of Calculations

- Geometry
- Structural
- Quantity
- Designer's Calculations – A structural analysis and design of the bridge and related components. Documentation of the work with hand calculations, computer output and detailed notes. The Design Engineer is responsible for the meaning and applicability of computer generated data.
- Design Check Calculations – A check of: the structural analysis and design of the bridge and related components, plan detail sheets, specifications and special provisions, and project quantities; Document the work with hand calculations, and computer output and detailed notes.

3.10.7.2 Importance of Calculations

Designers are responsible for well-organized, legible, neat design calculations properly assembled in a calculation book. Remember:

YOUR CALCULATION BOOK COULD BECOME AN EXHIBIT IN THE COURTROOM.

Be selective, including only calculations that actually support what the contract plans show. Do not include calculations that led down the wrong path and are not shown on the contract plans. However, calculation sheets voided by a project "redo" should not be discarded/deleted, but stored off-line, until it is certain they are no longer needed.

SUBMITTAL

Internally to ODOT, calculation books are a living document and reside in the appropriate PW folder. Calculations should be added to the book as developed, but at a minimum compile calculation books at each project milestone submission.

After an assigned project is completed and the project is awarded, submit a calculation book containing the design/check calculations for archiving. Submit electronic calculation book to ODOT Bridge Engineering Section at the Bridge Design Project Close Out.

For projects prior to October 2017, submit the electronic (contained in CD or USB thumb drive) calculation book to:

ODOT Bridge Engineering Section
4040 Fairview Industrial Drive SE, MS #4 Salem, OR 97302

For projects after October 2017, email the ProjectWise URN link for the completed calculation book to: bridge@odot.state.or.us.

Update calculation books when design changes occur during construction. See 3.12.5.2 for additional guidance.

The Bridge Engineering Section maintains the archiving process for all pertinent design/check calculations for documentation and future reference.

3.10.7.3 Calculations Books

For a bridge, the paperwork (usually excluding most correspondence) generated by the final design, and construction stages becomes a “set of calculations”, or a Calculation Book. Typically for a bridge, it includes:

(1) Design Calculation Book(s)

- Cover Sheet
- Table of Contents
- Designer’s QC Form
- Drafter’s QC Checklist
- Updated Bridge Design Standards Assessment Table
- Updated Design Criteria
- Approved Design Deviations/Exceptions
- Structural calculations
- Quantity calculations
- Copy of checked Engineer’s Estimate @ Final Plans
- Final Engineer’s Estimate of Probable Construction Schedule
- Construction stage calculations such as falsework calculations, alternate design checks, and design corrections or revisions
- Copies of Project Discussion Memos relevant to the calculations

(2) Check Calculation Book(s)

- Cover Sheet
- Table of Contents
- Checker’s QC Form
- “Line-by-Line” check calculations
- “Independent” calculations
- Quantity calculations

In the above lists, if it does not say “copy”, it means use the original.

Design calculations books must:

- Contain work from only one project. Request a different calculation book number for each project.
- Contain work from only one EOR. Calculation books can contain work from multiple EORs when they are working on different parts of the same structure, on the same project.
- Contain work for only one bridge when substantial structural analysis is required. Calculations books can contain work for multiple bridges when only minor or no structural analysis are required. If the expectation is unclear, clarify when creating the Bridge Design Work Order or SOW and document accordingly.

Check calculation books must:

- Not be combined with the Design calculation book.
- Have a unique calculation book number, unless it is a Class II check (BDM 3.5.7).
- Follow the same guidelines as the Design calculation book above.

Calculations for bridge load rating are handled differently from design calculations. Load rating calculations have their own calculation book and number. For details, refer to the ODOT LRFR Manual.

3.10.7.4 Calculation Book Cover Sheet

The first sheet of every set of design calculations is a completed Calculation Book Cover Sheet. This sheet must contain a PE stamp with signature. Digital signatures are acceptable.

For bridges, the design standards will normally be the AASHTO *LRFD Bridge Design Specifications*, modified or supplemented by:

- AASHTO *Interim Specifications*.
- ODOT *Bridge Design & Detailing Manual*.

3.10.7.5 Table of Contents

Keep the following guidelines in mind:

- Take time to tie calculation pages together by careful cross-referencing.

3.10.7.6 Calculation Sheets

Whether using hardcopy sheets or electronic sheets, fill out all headings completely for each sheet used. You may want to number the sheets of a set with its own sequence of numbers while working on an assignment, but you will need to renumber with page numbers in the upper right corners when the set is bound into a calculation book.

To make your calculations understandable to someone else (and yourself later):

- Put them in logical order.
- Show design assumptions
- Show formulas complete with references.
- Reference the source of any numbers taken from other calculations.
- Reference Design Deviations

3.10.7.7 Other Calculation Material

Make sure other material such as computer output, diagrams on graph paper, or completed forms also have the same identifying information as the calculation sheets.

3.10.7.8 Calculation Book Numbers

Each calculation book has its own number. See 3.10.7.3 for additional guidance.

Calculation book numbers are requested from and assigned by the Bridge Engineering Section. When requesting a calculation book number, fill out the request form at:

[Calculation Book Number Request Form](#)

Email request with completed form to: bridge@odot.state.or.us and a calculation book number will be emailed in return.

At the time Advance Plans are first distributed for review, the designer will need a calculation book number for the title blocks of the drawings.

Although more than one book may be used for a project with several bridges, do not reserve additional book numbers when requesting the first one. Book numbers for a project with several bridges are not required to run consecutively. Request additional book numbers when needed or when preparing a set or sets of calculations.

3.10.7.9 Page Numbering

For electronic calculation book, there is no limit for the pages.

3.10.8 Bridge Load Rating

At the completion of the design of the bridge complete the bridge load rating. See the ODOT LRFR Manual for guidance.

3.10.9 Operations and Maintenance Manuals

Bridge engineering has been changing and numerous emerging technologies are on the horizons that enable facility owners to improve the performance and/or to monitor the safety of their bridges. To ensure these innovations are properly applied and monitored for their effectiveness, the owner is requiring Operations and Maintenance manuals to be submitted along with the design calculations for all unconventional, complex or unusual systems or details. The specifics of the service manuals will be determined at the beginning of design of which they relate to the bridge type design selected.

The intent of this provision is to provide additional information to the agency for the efficient and effective operation of any innovations that are installed and specific to a facility. The manual may include shop drawings, fabrication details and manufacturer's technical product information. The manual should be clear in providing instructions on how and when to inspect and maintain the systems or details and how often to perform condition assessment of the unit.

Examples of deliverables:

- 1) NDT/E Monitoring Systems:
 - a) Example of deliverable: Operations and Maintenance Manual for all the NDT/E monitoring systems for recording fracture critical stresses and potential fatigue crack locations
- 2) Electrical and Mechanical Systems on Movable Bridges
 - a) Operations and Maintenance Service Manuals for the all electrical controls on movable bridges. Maintenance manual should include servicing the machine components and gears, brake systems, drive motors and span locks.
 - b) Operating instructions should include electrical service disconnect, wiring and labeling of electrical power distributions, traffic control systems, span lift control and lock systems, navigational and channel lightings, HVAC, fire and security alarms, and remote camera and sensing systems.
- 3) Seismic Monitoring Systems:
 - a) Operations and Maintenance Manual for seismic monitoring system for recording ground motions.
 - b) Operating instructions should include system inspection and checks, recorder working properly, troubleshooting, and accelerometers working condition.
- 4) Cathodic Protection Systems:
 - a) Operations and Maintenance Manual for all cathodic protection system to include such components like cabinets, wiring system, reference cells, anodes, and terminal plates.
 - b) Operating instructions should include system and inspection checks, battery power operated checks, trouble shooting, presence of corrosion, and sensors integrity check.
- 5) Bridge design types that are unique or unconventional to the Oregon:
 - a) Segmental and cable stayed bridges – inspection and maintenance manuals for its critical details and main force carrying components. Such examples include post-tensioning ducts and tendons, stay cables, anchorage and cradle details, deviators, pot bearings, modular joints, seismic isolation and/or damping devices, wind shear locks. Maintenance instructions should include the inspection and replacement of its components when they are no longer performing as designed.
 - b) Suspension bridges – inspection and maintenance manual for its critical details and main force carrying components. Such examples include main cable, saddles, anchorages, shoes, suspender ropes, corrosion protection systems, seismic isolation and/or damping devices, and wind shear locks.

3.11 PS&E TO AWARD

[3.11.1 Introduction](#)

[3.11.2 Changes to Bridge Deliverables after PS&E](#)

[3.11.3 Bridge Design Project Close-Out](#)

[3.11.4 Request For Information \(RFI\)](#)

[3.11.5 Addenda Letters](#)

3.11.1 Introduction

See [PDLT Operational Notice PD-07](#).

See [PDLT Operational Notice PD-08](#).

[Under development]

3.11.2 Changes to Bridge Deliverables after PS&E

Avoid drawing and estimate revisions after the Bridge Designer has signed the Final Plans. The Office of Project Letting needs a minimum of 24 calendar days prior to the advertising date for final preparation, review, and printing of the contract documents.

The Bridge Designer is responsible to see that these late changes are made and carefully documented. If a drawing is added to the Bridge Final Plans after a project is advertised, the Roadway Designer must be notified so that the drawing number can be added to the title sheet of the contract plans.

Although every attempt should be made to wait until after the contract is awarded, essential changes to the plans and special provisions, that would significantly affect the contract cost or character of the work, can be made during the advertisement period, by an Addendum Letter, up to 10 days before the bid opening, or letting, date. However, an Addendum Letter is expensive and causes additional stress for the Specifications Unit at a time when the pressure is great to get the job completed on time.

3.11.3 Bridge Design Project Close-Out

When the project contract is awarded, the Bridge Designer submits the following:

- Calculation Books
- Load Ratings
- Structural Analysis Programs
- CADD files
- Structure Cost Data
- Seismic Design/Retrofit Data Sheet located at:
<https://www.oregon.gov/ODOT/Bridge/Pages/Seismic.aspx>

3.11.4 Request for Information (RFI)

[Under development]

3.11.5 Addenda Letters

[Under development]

3.12 CONSTRUCTION SUPPORT

[3.12.1 Introduction](#)

[3.12.2 Communications during Construction](#)

[3.12.3 Shop Drawing Review](#)

[3.12.4 Temporary Works Review](#)

[3.12.5 Construction Support Close-Out](#)

[3.12.1 Introduction](#)

[Reserved for future use]

[3.12.2 Communications during Construction](#)

In the Preliminary and Final Design phases, except during the contract advertising period, the Bridge Designer may answer inquiries from outside ODOT about non-controversial projects. Politically or environmentally sensitive projects are another matter. Refer questions about them, especially those from the press or public, to the Bridge Engineer, or the Project Team Leader.

However, from the advertisement date until the project is awarded, the Construction Project Manager has sole responsibility for answering questions about the project. This insures equitable treatment of prospective bidders and avoids conflicting information about plans, specifications, and bid items. Therefore, avoid conversations with prospective bidders during this period and refer them to the Construction Project Manager listed in the front of the project special provisions.

[3.12.3 Shop Drawing Review](#)

[Reserved for future use]

[3.12.4 Temporary Works Review](#)

[Reserved for future use]

[3.12.5 Construction Support Close-Out](#)

3.12.5.1 As-Constructed Drawings

[See BCM Bridge CAD Manual 7.11.1 for guidance.](#)

3.12.5.2 Final Calculation Book(s)

Update calculation books submitted at design close out when design changes occur during construction. Follow the process and standards in BDM 3.10.7 for updates/changes to calculation books that are a result of construction. Incorporate the changes as an addenda/edit and update the table of contents, page numbers accordingly and resign, then resubmit book to ODOT. Significant design changes involving substantial structural analysis may necessitate a new calculation book.

3.12.5.3 Final Reports & Records

For Local Agency projects, to ensure that the requirements of the National Bridge Inspection Standards (NBIS) are followed under Title 23, submit an electronic pdf file of the following reports and records as part of the Construction Support Close-Out documentation:

- Pile Records
- Final Geotechnicals Report with documentation of changes made during construction.
- Final Hydraulics Report with documentation of changes made during construction.

3.13 (RESERVED)

3.14 COORDINATION WITH OTHER PROJECT TEAM MEMBERS

[3.14.1 General](#)

[3.14.2 Project Management](#)

[3.14.3 Survey and Mapping, & Right of Way](#)

[3.14.4 Roadway](#)

[3.14.5 Traffic and Mobility](#)

[3.14.6 Foundations and Geotechnical](#)

[3.14.7 Hydraulics and Scour](#)

[3.14.8 Environmental](#)

[3.14.9 Storm Water](#)

[3.14.10 Utilities](#)

[3.14.11 Railroad](#)

[3.14.12 Public Involvement](#)

3.14.1 General

Regarding permitting, in the situation of an interstate river crossing into Washington or Idaho, ODOT may need to apply for permits required by the other state if ODOT is the contracting agency.

3.14.2 Project Management

From a Project Leader's or Project Manager's viewpoint, the expectation of the bridge designer is to provide a high quality design per scope, on-time and on-budget. Keep your Project Manager informed of both positive and negative impacts to these items! No surprises!

Items to coordinate with your Project Leader or Project Manager:

- Scope / Scope creep
- Schedule
- Budget
- Overall project Quality Plan, and Bridge Quality Plan
- Local, and other non-environmental permits
- Bridge deliverables

3.14.2.1 Local & General Permits

Local and general permits may be required for a variety of subjects to complete the construction of a bridge or elements of a bridge. Some typical local and general permits that may need input from the Bridge Designer:

- Land Use
- Access Permit
- Conditional Use Permit (CUP)
- Riparian setbacks
- Floodplain
- Tree ordinances
- Willamette Greenway (along Willamette River)
- Noise variance
- Underground Storage Tank (UST)
- Canal, diking, and irrigation districts
- US Coast Guard Permit (for navigable waters)

Discuss permit needs (as they relate to the bridge) with the Project Leader/Manager. Provide needed information to the Project Leader/Manager to meet the permitting schedule for the project. Providing this information late will delay the process to apply for and obtain necessary permits, and ultimately delay the letting date of the project.

3.14.3 Survey and Mapping, & Right Of Way

3.14.3.1 Survey and Mapping

Obtain survey and mapping data. Visit the project site with survey data and mapping in hand to 1) get an “on the ground” feel for the lay of the land, and 2) visually check the survey and mapping data for any discrepancies. Identify or confirm site constraints known at this time (see [BDM 3.18.1](#)).

3.14.3.2 Right Of Way

This provision is only applicable to new bridges and the widening of an existing bridge.

Include any proposed and existing right-of-way limits and any construction easements with the vicinity map information. Ask yourself: Can the bridge and the contractor’s operations (work bridge, shoring, falsework, future inspection and maintenance staging areas, the potential need for a detour structure, etc.) be accommodated within these limits, as well as safely ingressing and egressing to and from the highway system by agency personnel?

In order to ensure the bridge inspectors and bridge maintenance personnel have a safe place to park vehicles and stage maintenance operations, behind the approach guardrail, the Bridge Designer works with the Roadway Designer to identify the appropriate space. If the bridge is located over another roadway, consider additional parking/staging space behind the undercrossing route railing. In order to provide a safe ingress and egress from the highway system, the Bridge Designer is encouraged to locate these areas behind the trailing end guardrail.

For the bridge project that has very minor roadwork, verify that steps to acquire necessary right-of-way have been initiated.

For questions about right-of-way data, contact the project’s Roadway Designer, who is in touch with the Right-of-Way Engineering Group and Right-of-Way Services personnel.

3.14.4 Roadway

3.14.4.1 Project Geometry

Review the project geometry with the Roadway Designer to verify that you have the latest alignment, roadway cross-sections, and grades. Some questions to consider:

- Do grades, superelevations, etc., provide enough vertical clearances for the type of bridge anticipated?
- Is the choice of bridge width and horizontal and vertical alignment consistent with traffic volume and type of highway?
- Bridges that are more susceptible to roadway surface icing and have superelevation rates in excess of 0.08 ft/ft are considered hazardous under those conditions. Use greater rates only if special study has determined that the greater rate is desirable.

3.14.4.2 Roadway Clearances

Clearances required for highway overcrossings are shown in *Figures 3.14.4.2A, A-1, B and C.*

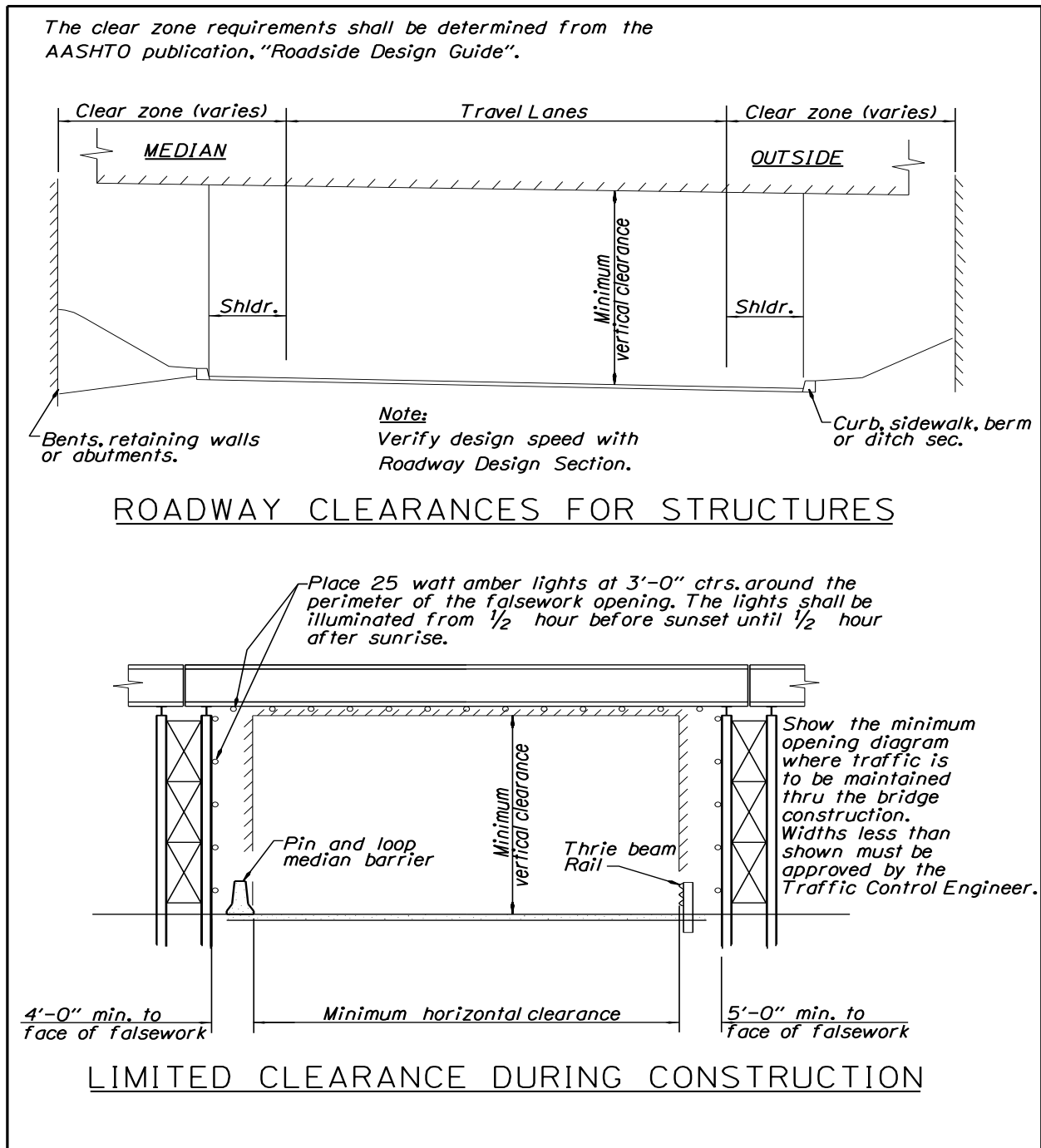

Note: Use 18'-0" min. horizontal clearance for 1 lane (19'-0" for interstate).

Figure 3.14.4.2A

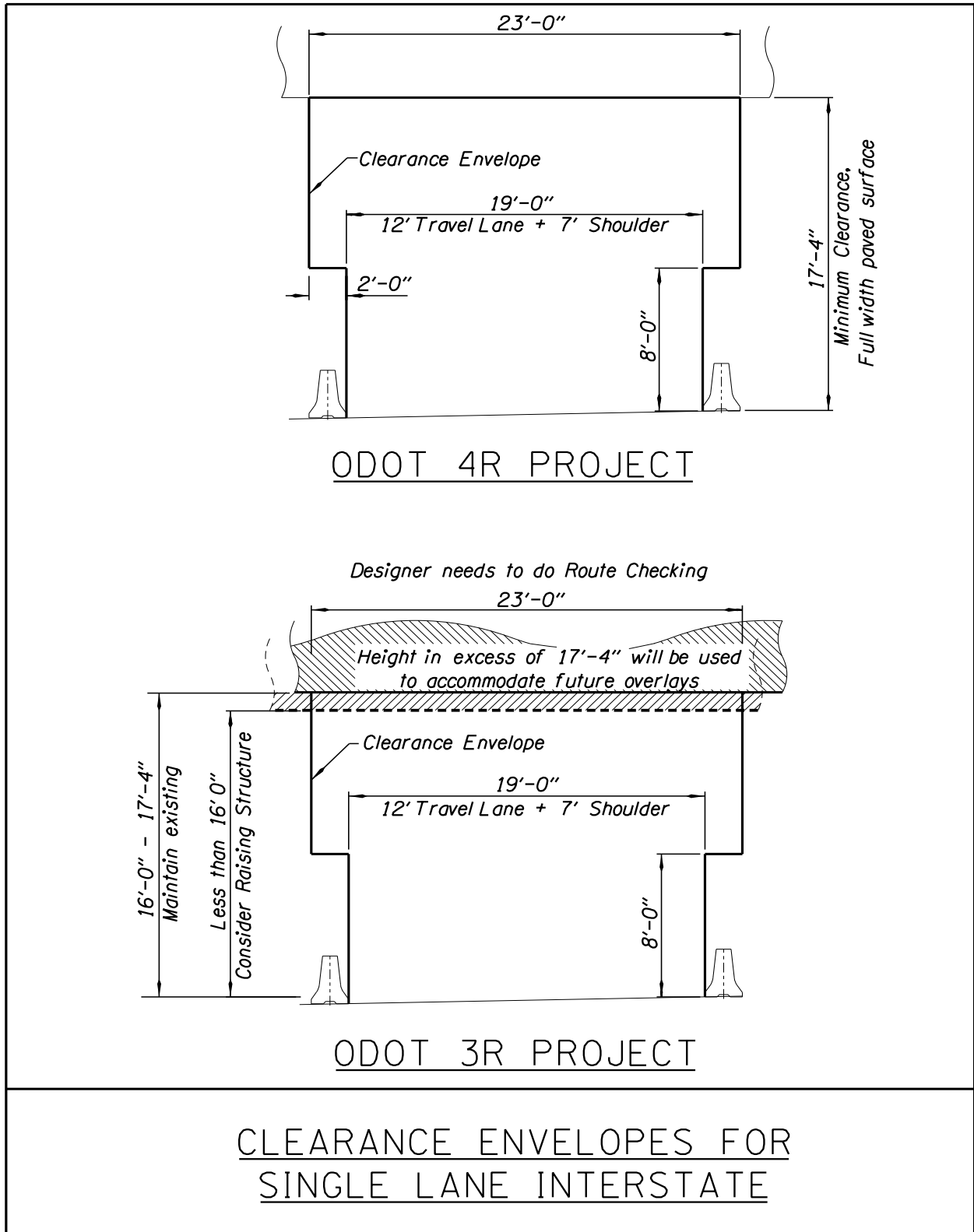

Figure 3.14.4.2A-1

(1) Roadway Widths

Coordinate the roadway width with the Roadway Designer at the beginning of the Preliminary Design Phase.

In most cases, the bridge roadway width will be 4 feet wider than the approach roadway width.

Normal Bridge Roadway Width = Lanes + Shoulders + 4'

This applies to all classes of roads regardless of the ADT and type of traffic. The major exception to this is the one-way single-lane ramp (26' roadway).

Increase shoulder widths by 2 feet where roadside barriers are used. The 2 foot shy distance is normally not required adjacent to a raised sidewalk that has a traffic rail at the back of the sidewalk.

For local agency projects on the NHS system, verify the roadway width using AASHTO Publication, "A Policy of Geometric Design of Highways and Streets".

(2) Sidewalk and Bikeway Widths

The width of sidewalks on State projects are as follows:

Designated separate bikeways on bridges	8' minimum
Urban areas	6' to 8'
Rural areas	5'

Sidewalk ramps are required at all intersections and other crosswalks for disabled persons. Use the details on "Sidewalk Ramps", *Drawing RD725*.

(3) Height of Curbs and Sidewalks

Use 7 inch height when the rail used at the back of the sidewalk is structurally adequate and has been crash-tested.

(4) Vertical Clearance

Vertical clearance policy is established by the Roadway Engineering Section and is listed in Section 4.5 of the Highway Design Manual.

Review and comply with the Oregon Vertical Clearance Standards Map and High Routes (High Routes are highway segments that are the most important when high loads are moved) Highways Table during development of the TS&L (and DAP). Additionally, before finalizing the clearance of the bridge, consult with the Pavement Designer to determine if an additional allowance is required for future pavement preservation treatments. If the bridge project consists of 3R preservation work and a decrease in the vertical clearance below the level of the minimum vertical clearance is proposed, ensure that the Roadway Designer has consulted with the Permit Program Coordinator for the Motor Carrier Transportation Division (MCTD), and a Design Exception Request has been submitted. The Permit Program Coordinator for MCTD will need to collaborate with industry and with the Mobility Steering Committee before providing a written response to the project development team. Follow the same process when proposing a reduction to the vertical clearance requirements for a new bridge. No reduction of the vertical clearance on existing bridges, or a reduction in the standard for a replacement bridge will be allowed without written approval from the Motor Carrier Transportation Division (MCTD). Include a copy of the approved Design Exception for a non-standard vertical clearance in the calculation book.

All new bridges where no vertical clearance limitations currently exist require consultation with MCTD to ensure that ODOT understands the impact of the proposed decrease to the user.

Vertical Clearance Design Standards:

Minimum Vertical Clearances are actual measured heights, representing the shortest allowable distance between the lowest point on the underside of a bridge and the surface of the pavement for the entire width of the roadway, including shoulder area. Minimum Vertical Clearances include a 4 inch buffer, but do not take into account additional height for any future pavement overlay thickness.

New Construction Projects – Minimum Vertical Clearances:

High Routes	17' - 4"
NHS (not on High Routes)	17' - 0"
non-NHS (not on High Routes)	16' - 0"

Other Projects

- No reduction in existing vertical height clearance below the Minimum Vertical Clearances
- No reduction in vertical clearance if existing vertical height clearance is below the Minimum Vertical Clearance

Legal Load Height

The maximum height for legal loads is 14 feet.

(5) Clearances during Construction

Horizontal and Vertical Design Policy for clearance during construction has been established by the Traffic-Roadway Engineering Section. Coordinate with the Traffic Control Plans Engineer for minimum clearances applicable on the project. If the clearances required cannot be maintained during construction consult with the Traffic Control Plans Engineer for concurrence and notify MCTD.

Horizontal Clearance:

Freeway Mainline (Not within a Crossover):

One Lane	19' – 0" (16' – 0" if over-dimensional loads and annual permits are detoured)
Two Lanes	28' – 0" (28' – 0" if over-dimensional loads and annual permits are detoured)

Freeway Crossover:

One Lane	19' – 0" (16' – 0" if over-dimensional loads and annual permits are detoured)
Two Lanes	32' – 0" (28' – 0" if over-dimensional loads and annual permits are detoured)

Non-Freeway Roadways (Freight Route)

One Lane	19' – 0" (14' – 0" if over-dimensional loads and annual permits are detoured)
Two Lanes	28' – 0" (28' – 0" if over-dimensional loads and annual permits are detoured)

Vertical Clearance:

For locations with an existing clearance 17'-0" or greater, provide 17'-0" minimum vertical clearance. For locations with an existing clearance less than 17'-0", no reduction in clearance will be allowed during construction. Always notify the MCTD if reduction of the existing vertical clearance is planned for the construction season.

3.14.4.3 Bikeways

Oregon law requires that reasonable amounts of highway funds be spent for bicycle and pedestrian facilities. That means: consider bikeway staging needs wherever highways, roads, or streets are being constructed, reconstructed, or relocated.

“Bikeway” is a general term meaning any road or path open to bicycle travel regardless of whether it is designated for bicycles or to be shared with pedestrians or automobiles. Specific types of bikeways are:

- Bikes lanes or bike paths
- Shared roadways
- Shoulder bikeways
- Sidewalk bikeways

To work with bikeways, you are going to need:

- *Oregon Bicycle Plan*
- *AASHTO Guide for the Development of Bicycle Facilities*

3.14.5 Traffic and Mobility

3.14.5.1 Traffic Handling and Data

Used here, traffic includes:

- Vehicles
- Bicycles
- Pedestrians (including the disabled)

There are four traditional methods of handling traffic when replacing a bridge:

- Close the highway while removing and rebuilding the bridge
- Construct a temporary detour around existing bridge and replace the bridge on the existing alignment
- Use the existing roadway and bridge while constructing a parallel bridge on new alignment
- Use stage construction with one or more existing or new lanes carrying traffic while other portions of the existing bridge are being removed and rebuilt

Often the last method is recommended over the second and third methods. However, without proper investigation stage construction may:

- Cause a high number of complaints from the traveling public
- Mean greater danger for ODOT and contractor personnel as well as to the public
- Result in construction difficulties and longer construction time
- Adversely affect the quality of the finished product

Consider the various methods of handling traffic:

- Is the method proposed by the field the most reasonable way to build a project
- Are there alternate and possibly more satisfactory solutions

When site constraints do not allow the use of traditional methods, Accelerated Bridge Construction (ABC) methods may be warranted. See *BDM 3.24*, “Accelerated Bridge Construction Guidelines”.

3.14.5.2 Moveable Bridge Traffic Control Equipment

Work closely with the traffic signal and sign designers to ensure design from each discipline is detailed or referenced appropriately. Refer to the [ODOT Traffic Signal Design Manual](#): Chapter 23 for moveable bridge traffic signal and sign design guidance. See *BDM 1.27*, “On-Bridge Sign & Illumination Mounts” for bridge mounted traffic structure guidance.

Detail the following items on the Bridge Plans Sheets:

Bridge Design Manual – June 2020
Oregon Department of Transportation
Section 3 – Processes & Roles

- Control system that activates the traffic signals and flashing beacons (cabinets, power source, termination of wires, etc.)
- Location of Gate arms
- Audible devices for warning traffic
- Non-standard poles, foundations, or mounting for signal heads, signs, and flashing beacons
- Electrical conduit routed on/through the bridge structure (including expansion fittings)
- Junction Boxes located on the bridge structure

Detail the following items on the Signal Plan Sheets:

- Location of the traffic signals
- Location of the STOP line
- Use of and location of the flashing beacon warning devices
- PTR signs (site specific for the I-5 NB and SB Columbia River Bridge only)
- Wiring from the traffic signals and flashing beacons to the control system (wire terminations are detailed on the bridge plans)
- Electrical conduit not routed on/through the bridge structure
- Connection details for conduit going onto (or off) of the bridge structure (Junction box, expansion fitting, etc.)
- Standard poles, foundations, and mounting for signal heads, signs & flashing beacons

Detail the following items on the Signing Plan Sheets:

- Ground mounted signs that do not have a flashing beacon

3.14.6 Foundations and Geotechnical

See *BDM 1.10*, "Foundation Considerations".

3.14.7 Hydraulics and Scour

3.14.7.1 Hydraulics, General

The Hydraulics Designer will provide data and recommendations in support of bridge foundation and scour protection design.

3.14.7.2 Waterway Openings and Hydraulic Requirements for Stream Crossings

Design Discharges

The design discharge for bridges on Interstate Highways and highways with an Average Daily Traffic (ADT) greater than or equal to 750 is the 50-year flow. The design discharge for bridges along highways with an ADT of less than 750 is the 25-year flow. Bridges spanning over designated FEMA floodways are designed using the 100-year flow (base flood).

Bridge waterway opening

The bridge waterway opening must be capable of conveying the design discharge with the appropriate clearance to the projected design high water elevation according to the following:

- Width of waterway opening is measured normal to stream flow. The waterway area is the normal channel area below the design discharge high water elevation. Minor channel cleanup and modification is acceptable, but major lowering of the streambed under the bridge to increase the opening is not only ineffective but unacceptable.
- The Hydraulics report will determine the high water elevation at the upstream face of bridge. The minimum bottom-of-beam clearance to the high water elevation is 1 foot or 3 feet if drift or debris is a concern (the hydraulic designer will review the bridge inspection reports and check-in with District to confirm any ongoing debris issue, and then coordinate debris criteria with the project team when applicable). If practical, 1 foot of clearance above the 100-year flood elevation is provided. Also note that there is “no net rise” in water elevation allowed at bridges that will cross over a FEMA regulatory floodway.

The exception would be for county and city bridges whose approaches are overtopped more frequently than once every 10 years. The minimum bottom-of-beam elevation provided for these situations is 1 foot above the 10-year design flood elevation.

- Under rare circumstances, such as a park settings or where other controls on grade lines make it necessary, high water above bottom of beam, or over the deck, may be allowed.
- Ordinarily, the design flood should not overtop the adjacent roadway. When the roadway over topping flood is less than the design flood, the overtopping flood becomes the design flood.

If there are no future plans to raise a roadway to eliminate overtopping, a combination of bridge waterway opening and overtopping at the low points of adjacent roadway may be an acceptable alternate to accommodating the entire stream flow under the bridge. For Interstate Highways, the minimum overtopping frequency is 50 years.

Roadway overtopping at lesser recurrence intervals than the 50/25 years is acceptable and allowable in certain circumstances such as:

- Other roads in the area are overtopped
- Traffic counts are low
- Alternate routes are available

- Road is useable when overtopped (shallow overtopping)
- The required bridge would be excessively long or high and a review is made of the effect of backwater and overflow on adjacent properties and facilities

3.14.7.3 Bridge Scour Design

(1) Scour Evaluation and Design

The scour analysis can be referenced in the project Hydraulics report. The scour analysis shall include analysis on possible long term changes in the channel bottom elevation due to either aggradation or degradation, possible shifts in channel alignment, contraction scour and local pier scour. Abutment scour and the potential for “washout” conditions are also evaluated. Scour depths are calculated for both the 100-year (design/base flood) and 500-year (check flood) events. However, if the incipient roadway-overtopping flood can occur, it is usually the worst case for scour because it will usually create the worst scour conditions at the bridge site (greatest flow contraction and highest stream velocity). Therefore, scour depths are calculated depending on the recurrence interval for the overtopping flood.

(2) Scour at Bridge Abutments:

The potential for scour at the bridge abutments must also be considered at all waterway crossings. Abutment scour, lateral stream migration (channel changes) or overtopping of the approach embankment could all result in partial or complete removal of approach fill material and severely destabilize the abutment foundation and the bridge. A “washout” condition could occur under any of these conditions where the approach embankment supporting the abutment foundation is completely scoured out. Evaluate each of these three conditions as described below:

- Abutment Scour: ODOT policy states that abutment scour calculations are not required if abutment and approach fill slopes in the waterway are protected with a properly designed revetment protection system, such as a riprap blanket with a toe trench extending down to the maximum scour elevation. Revetment methods are discussed in the ODOT Hydraulics Manual, *Chapter 10*, and in the FHWA Highway Engineering Circular No. 18 (*HEC-18*). The revetment protection must be capable of withstanding the velocities and flow associated with the check flood event. With this level of protection, the scour prism is reduced to just the contraction scour, scour from degradation and local pier scour (if applicable) for use in scour design of the bridge.

For abutments and bridge fill slopes in contact with stream flow or wave action and not protected with permanent revetment measures, abutment scour is calculated (if hydraulic and site conditions are appropriate). Abutment scour could lead to destabilization of the bridge end slope and loss of embankment material supporting the bridge foundation and abutment. If this condition is possible, then consider the potential for a full washout condition for both the 100 and 500 year flood events.

- Roadway Overtopping: Overtopping of the approach fill near the bridge end may also result in a washout condition (ref. *HEC-18* and *AASHTO 2.6.4.5*). Consider this condition in cases where the overtopping is located in the proximity of the bridge end and a breached embankment could result in the scour and removal of fill material supporting the bridge abutment foundation. Properly designed slope protection and revetment may provide sufficient mitigation against the potential for a washout condition depending upon site conditions. However, because each overtopping case is unique, carefully evaluate each for the potential of a “washout” condition. If a “washout” condition is considered feasible, the amount of embankment material that could be removed, and the scour depths, are to be determined by the Hydraulic Designer.
- Lateral Stream Migration: Evaluate the potential for lateral streambed migration (channel changes) for possible detrimental effects leading to erosion or scour of the bridge approach fills. For unprotected, or even well protected, abutment slopes, if there is a possibility that the stream channel could shift toward the abutment such that the revetment might not be relied upon for permanent protection, then

assess the condition of a full or partial washout of the abutment fill material. The potential and likelihood for stream channel migration and the resulting affects, is determined by the Hydraulic Designer who also determines whether protective measures such as channel guides, stream bank stabilization techniques or other measures could be employed to mitigate this potential. The hydraulic design and any stream bank stabilization measures must demonstrate that the channel won't migrate toward the abutment such that it could cause a destabilization of the slope and a potential "washout" design condition.

Under a washout condition, neglect all foundation support (vertical and lateral) provided by the embankment material beneath the abutment down to the scour elevation associated with both the Design Flood (base flood) and Check Flood events (excluding local pier scour). Design the foundation to be capable of supporting the bridge loads under both of these design conditions as described in the AASHTO LRFD Bridge Design Specifications.

Abutment scour conditions which could result in partial or complete washout of the material supporting the abutment foundations may occur at one or both of the bridge abutments depending on the site conditions. For sites with potential washout conditions, investigate the bridge for the washout condition that would produce the worst case unbalanced loading in the bridge, provided that case is feasible. This is often the case for strutted abutments where the passive resistance of the abutment backfill material is crucial to the stability of the bridge and a washout condition behind only one abutment could lead to unbalanced loads and failure of the bridge.

For washout conditions at abutments supported on deep foundations, debris loads on the end bent piles or shafts are not included in this analysis.

(3) Scour Design

For scour depths associated with the Design Flood, (typ. 100-year flood or overtopping flood if it is more frequent), check the bridge design at both the Service and Strength Limit States (per *AASHTO Article 3.7.5*). For scour depths associated with the Check Flood (500-year flood or overtopping flood if it controls) provide adequate foundation resistance to support the unfactored Strength Limit State loads (per *AASHTO Article 10.5.5.3.2*).

Only the scour due to long term stream bed degradation is included in the seismic design of the bridge (Extreme Event Limit State I).

3.14.7.4 Hydraulics Documentation

The Hydraulics Designer will prepare and provide three design report deliverables for bridge projects as follows:

- Preliminary Bridge Hydraulics Recommendations
- Draft and Final Hydraulics Report

Preliminary Bridge Hydraulics Recommendations

The bridge hydraulic recommendations is prepared and distributed to the project team after the kick-off meeting and before submitting the hydraulic survey request.

- Bridge, geotechnical, roadway, traffic, and hydraulic designers review scoping notes. The design details such as alignment (horizontal/vertical changes), site constraints, bridge layout and approach embankments, traffic control, and hydraulic concerns such as highly erodible floodplains or channel lateral migration that could washout embankments are discussed and coordinated between team

members.

- Bridge designer outlines bridge/structure type, and geometry such as bent locations, width, and wingwalls.
- The hydraulic designer will prepare a preliminary bridge hydraulics recommendation which is distributed to the project team and is based on coordination between the project's bridge, geotechnical, and hydraulic designers. The recommendation includes a preliminary idea of the hydraulic structure type, size, location, and special features or concerns. An example of this report is provided at the following link: [Hydraulics Recommendation Example](#)

Hydraulics Report

The hydraulic modeling and analysis begins after obtaining the hydraulic survey data. It is good practice for the roadway, bridge, geotech, and hydraulic team members to check-in with each other at this point (just prior to the start of the hydraulic model task) so any changes are reflected in the model.

The hydraulics report provides detailed information that supports structure and roadway design. The report includes hydrologic calculations, 1D/2D bridge hydraulics modeling results for permanent and temporary bridges, scour analysis, revetment design, floodplain impact analysis, and the temporary water management summary and concept plan sheet.

The hydraulic designer will prepare the “draft” hydraulics report during the DAP phase, which is provided with the DAP submittal package. The hydraulic and bridge designer will need to review the project delivery schedule and make sure that the “draft” hydraulics report is complete and available for use to develop the TSL and bridge DAP deliverables. The “final” hydraulics report is provided with the Advanced submittal package.

A general outline of the modeling and distribution of hydraulic data during the DAP phase of a project is provided below:

1. Hydraulic designer prepares model
2. Model results are summarized in a “hydraulics data sheet”
3. Scour analysis performed
4. Revetment sizing performed
5. The results of the model are shared with the bridge designer as soon as the details are added to the hydraulics data sheet.

All hydraulic reports will have a hydraulic data sheet for the proposed structure, see *Figure 3.14.7.1*. The data sheet includes the following information:

- Discharge and recurrence intervals for the design event, base flood and the 500-year or roadway overtopping flood.
- Backwater conditions with the new structure in place
- Headwater and downstream water surface elevations at the bridge, and
- The average water flow velocity at the bridge

The information in the hydraulics data sheet is used to perform the scour and revetment analysis.

The hydraulics data sheet, and scour/revetment results are shared with the design team members at this point to perform the following design tasks:

- bridge designer will need to confirm or implement the following:
 - verify the bottom-of-beam elevation is 1 or 3 feet higher than the design event “high-water elevation at upstream face of bridge”.
 - add the extent of abutment riprap on bridge plans “plan and elevation view” and note “see roadway plans for riprap details”. Revetment design recommendations will be detailed in the report sub-section for revetment. The roadway plans will include the riprap detail with the following information (1) riprap thickness (2) filter blanket thickness when applicable, (3) class of riprap, and (4) toe trench configuration and dimensions. An example of the riprap detail to be included on the roadway plans is illustrated in *Figure 3.14.7.2*.
 - verify the end and interior bent supports (piles, shafts, footings) are below the scour elevation stated on hydraulic data sheet or in the report sub-section for scour. The design summary will note when footings are to be anchored into rock as coordinated between bridge engineer and geotechnical engineer.
 - add the “hydraulics data” table to the bridge plans, see *Figure 3.14.7.3*.

BRIDGE

PROJECT: Oak Creek Bridge # 18463
Pacific Hwy - Lebanon (RR Tracks) Section
Corvallis - Lebanon Highway, M.P. 12.48
Linn County Key # 06420

COMPILED BY: _____

DATE: 6 October 1997

TABLE 2: Proposed Bridge	HYDRAULIC DATA			
	DESIGN EVENT	BASE FLOOD	ROADWAY OVERTOPPING FLOOD	ORDINARY HIGH WATER
Discharge (cfs)	1,850	2,390 ⁶	2,060 ⁵	-
Recurrence Interval (yrs)	50	100	80	
Approach Section H.W. Elevation w/Natural Channel ¹ (ft)	277.0	277.5	277.2	-
Approach Section H.W. Elevation w/ Bridge ¹ (ft)	277.8	278.4	278.0	274.7
Backwater (ft)	0.8	0.9	0.8	-
H.W. Elev. at Upstream Face of Bridge ² (ft)	277.7	278.3	277.9	274.6
H.W. Elev. At Downstream Face of Bridge ³ (ft)	276.5	276.9	276.7	274.4
Waterway Area at Downstream Face of Bridge ⁴ (ft ²)	290 (331)	290 (331)	290 (331)	--
Average Velocity at Downstream Face of Bridge (ft/s)	6.4	7.0	6.4	-

¹ Approach section is one waterway opening width upstream from upstream face of bridge.

² Located at upstream face of bridge along the embankment.

³ Located at downstream face of bridge opening.

⁴ Area normal to channel centerline. Area in parentheses is parallel to roadway centerline.

⁵ 1,870 cfs flows under the bridge and 190 cfs flows through culverts west of the bridge.

⁶ 2,030 cfs flows under bridge, 170 cfs flows over road to west of bridge, and 190 cfs flows through culverts to the west of the bridge.

REMARKS:

The spillthrough structure is a 70-foot long single-span bridge with combination spillthrough/vertical abutments. The structure is skewed 29 degrees. Three 36-inch diameter culverts are located under the roadway to the west of the bridge.

Manning's "n" bridge opening = 0.04

Manning's "n" main channel = 0.04

Manning's "n" overbanks = 0.04

Figure 3.14.7.1

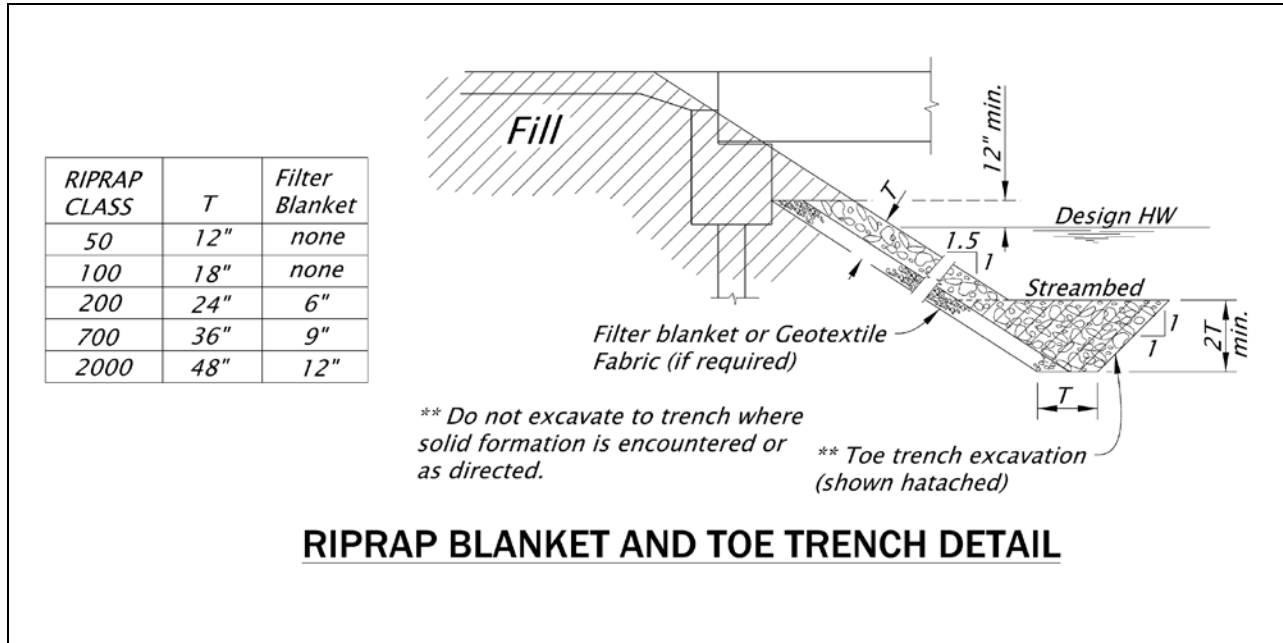

Figure 3.14.7.2

HYDRAULIC DATA				
ITEMS	(UNITS)	DESIGN FLOOD	BASE FLOOD	500-YEAR OR ROADWAY OVERTOPPING FLOOD
DISCHARGE	(cfs)	1850	2030	1870
RECURRENCE INTERVAL	(years)	50	100	80 (overtopping)
HIGH WATER ELEVATION AT UPSTREAM FACE OF BRIDGE	(feet)	277.7	278.3	277.9
BACKWATER	(feet)	0.6	0.9	0.8
SCOUR ELEVATION ¹	(feet)		266.0	

¹Scour elevation is provided in hydraulic report section titled "scour"

Figure 3.14.7.3

3.14.8 Environmental

Avoid, Minimize, Mitigate...

3.14.8.1 Environmental Performance Standards & Permits

See [PDLT Operational Notice PD-04](#) and the technical guidance document under References at the end of the Notice.

Environmental Performance Standards are considered during Project Scoping to help avoid unanticipated project costs from permit requirements and to ensure enhancement options are considered and, where appropriate, included in the project budget.

Environmental Performance Standards determined to be applicable during Scoping are reevaluated at Project Initiation. During the Project Kickoff Meeting, identify design constraints and required permits.

Some environmental rules, regulations, permits and other topics that may be applicable on projects with bridges that may need discussion with the Environmental Specialist, or input from the Bridge Designer:

- National Environmental Policy Act (NEPA) (Requires that any activity or project receiving federal funding or other federal approvals undergo an analysis of potential impacts to the environment.)
- In-Water Work Windows (Permissible time to work inside the Regulated Work Area.)
- Archaeological, Historic and Cultural Resources (Identify areas to avoid.)
- SHPO Section 106, National Historic Preservation Act
- Section 4f – US Dept of Transportation Act of 1966 (Protects three basic types of resources: publicly owned parks and recreation areas, publicly owned wildlife and waterfowl refuges, and historic sites.)
- Section 6f of the Land and Water Conservation Act (Prevents property from being converted from outdoor recreation to any other use.)
- Visual effects (looking away from the bridge, or looking at the bridge from afar)
- Hazardous Materials (Disposal of treated woods, lead paint, and old construction materials containing asbestos.)
- Piling removal
- Rip-rap bent protection (Exclusion can affect type, size and location of the bridge's foundations.)
- Wetlands
- Clean Water Act Sections 401, 402, & 404
- Fluvial (Width of waterway to allow for natural meandering of the stream. Affects the length of the bridge and pier location.)
- ODFW Fish Passage Criteria
- USFW / NMFS Migratory Bird Treaty Act
- USFW / NMFS Endangered Species Act
- Wildlife passage accommodations (May need to provide additional horizontal or vertical clearances for wildlife passage.)
- Joint ACOE / Oregon DSL Removal-Fill Permit
- Access & Staging Areas (Estimate/Identify adequate areas for the contractor to stage work in so it can be environmentally cleared for use.)

Discuss permit needs (as they relate to the bridge) with the Environmental representative on the Project Development Team. Provide needed information to meet the permitting schedule for the project. Providing this information late will delay the process to apply for and obtain necessary permits, and ultimately delay the letting date of the project.

Even if no permit is required, restrictions or comments from the permitting agency may have to be shown on the contract drawings or stated in the special provisions.

3.14.8.1.1 Permit Information Memo

The need to supply the required permit information as soon and as accurately as possible cannot be overemphasized. Some applications take 6 or more months to get approval.

It is not recommended to try to include all the necessary information for all the various permits in the TS&L Report – it can become unwieldy, and takes away from the purpose of the TS&L Report. Instead, it is recommended to prepare a separate memo to convey information for use in preparing and applying for the various permits that are needed to complete the project.

TS&L Plan & Elevation drawings and vicinity maps may also be used as a basis for special permit drawings; but strip them of any information not needed to obtain the permit. Keep in mind: the people reviewing the applications are not structural designers. They do not have time to sift through many drawing details and dimensions not relevant to the permit approval.

Topics that may require the Bridge Designer's input include:

- Project timing and chronology.
- Alignment and size of the new bridge in relation to the existing bridge (i.e., number of spans, length).
- Quantity of impervious existing bridge surface removed and added by the new bridge.
- Type of the new deck surface and construction methods.
- Type of the new bridge railing and construction methods.
- Proposed treatment of the runoff (i.e., number of scuppers or direct discharge drains on the old bridge vs. number of drains on the new bridge)
- Number and sizes of the existing bents/footings to be removed within the OHWM and the wetted channel. Discuss the removal methods of the existing bents, footings and piles.
- Number and sizes of bents/footings added for the new bridge, within the OHWM and the wetted channel. Discuss the construction methods for the new footing, bents and piles.
- Type of isolation method used during construction (i.e., cofferdam).
- For bridges with lead based paints, discuss the method of removal and disposal.
- If a detour bridge, working bridge, or falsework are required, discuss how many bents and types of temporary supports that may be within the OHWM and wetted channel. Discuss the construction and removal methods that might be used.
- Extent and duration of in-water work (i.e., heavy machinery in wetted channel).
- Amount or extent of fill or rip-rap.
- Possible staging areas and access.
- Amount and type of vegetation to be removed (outside and within the OHWM).
- Amount of wetland impacted.
- Any planned mitigation.

3.14.8.2 Protection of Recreational/Cultural Resources

Be alert to the effects of construction on:

- Recreational activities, areas, or facilities.
- Cultural resources such as fossils, artifacts, burial grounds, or historical bridges and dwellings.

Refer to *SP 00290*, “Environmental Protection”, specifically *SP 00290.50*, “Protection of Cultural Resources”, in the *Standard Specifications for Construction*.

Although normally researched and proposed by ODOT’s Environmental Section, protection or consideration of these activities or resources can be initially overlooked. Permit requirements from agencies like the U.S. Army Corps of Engineers or Oregon Department of Fish and Wildlife deal with historical, cultural, and recreational concerns too. Here are some examples of challenges from the past:

- Protection of summertime river rafters passing under a contractor’s work bridge.
- Removal of large amounts of river debris hung up on cofferdams and endangering a collegiate racing crew practicing downstream.
- Saving of old or rare trees near a city bridge construction site in deference to neighborhood sentiment.

3.14.8.3 Bat Habitat

As there are no regulatory requirements (state or federal) for establishing bat habitat on bridges, use discretion when providing the habitat. Do not provide bat habitat if it compromises the structural integrity of the bridge, interferes with maintenance and inspection activities, or creates a public hazard. Consider off-bridge habitat when applicable.

Use standard details for the design of bat habitats. Only include bat habitat details when requested by Region environmental staff. The bridge types utilized in the standard details are side-by-side precast slabs, side-by-side precast box beams, precast Bulb-T bridges and precast Bulb-I bridges. The type of habitats included in the details are longitudinal slotted habitat in the slab and box beam bridges, transverse slotted habitat in the precast Bulb-T and Bulb-I bridges, and “cave habitat” in precast Bulb-T and Bulb-I bridges.

The selection of cave or slotted bat habitat depends on the species of bats that occupy the area. This can be determined by the Environmental Section.

The slotted habitats are typically 3/4” thick and have varying depths depending on the bridge superstructure elements. For precast slabs and box beams, the slots are formed with 3/8” recesses in each of the two adjoining members. The use of a 3/4” recess in one member only was considered but rejected because of the risk of corrosion. A roughened recess surface is provided by sand blasting or forming.

Slotted habitats used in precast Bulb-T and Bulb-I girders are formed using 3/4” thick precast greystone panels with roughened surfaces. Three panels are used with a clear spacing of 3/4” between each panel. They are placed transversely to the beams and in contact with the bottom of the top beam flanges and the bottom of the deck. This was done to provide thermodynamic contact with the upper concrete. Access slots are provided at the bottom of the panels.

The cave habitats are also detailed for precast Bulb-T and Bulb-I girders. They are formed using precast or cast-in-place vertical walls and precast floor panels. The decision between precast or cast-in-place wall panels can be made by the designer, or left to the contractor. The complexity of fitting up the precast wall panels between the two precast girders may control this decision. In either case, the wall panels will be held in place by steel angles anchored in the precast beams. Provide access holes for the bats in both the floor panels and the end wall panels.

The location and number of habitat elements will be project specific depending on the population of bats in the area.

Locate bat habitat features using the following guidelines:

- Do not place bat habitat directly over a roadway or walkway. Bat guano can be a hazard to bridge inspectors, maintenance staff and the general public. If bat guano is allowed to accumulate and dry on a roadway or walkway, vehicle or pedestrian traffic will cause the guano to become airborne resulting in an increased health hazard.
- For vertical slot bat habitat, such as used with precast slabs and boxes, place slots at least 12 feet away from abutments and interior bents. This requirement provides a guano-free zone for bridge inspection access to bearing locations. In addition, do not place slots within 5 feet of midspan.
- For cave-type habitat, often used with precast girders, do not place habitat within 15 feet of the abutments and interior bents. This requirement provides a guano-free zone for inspection of both bearings and the maximum shear portion of girders. In addition, do not place habitat within 10 feet of midspan.
- For abutment roughening that provides area for roosting, limit roughening to no more than 25 percent of the horizontal abutment face. It is preferable to keep roosting areas limited to the corners (closest to the exterior edges of the abutment).

Where proposed bat habitat details do not meet these guidelines, submit a design deviation.

3.14.9 Storm Water

[Reserved for future use. (If you have deck drainage, you have Storm Water coordination.)]

3.14.10 Utilities - Roles and Responsibilities

(1) District Roles and Responsibilities

The Districts are the main point of contact for the location of all utilities and will issue all utility permits. (Utility permits are issued by ODOT to the utility companies.) Utility permits allow the installation, relocation, and removal of utilities within the State right-of-way. Utility companies will only be given a permit for the specific area they actually need for that installation. Space for future lines will need to be included on a separate permit application. If the utility installation requires holes to be drilled into the bridge, if the utility will add a significant amount of additional dead load on the bridge, or if the installation has the potential to be in conflict with any of the items in *BDM 3.14.10.1-(3)* and *BDM 1.25.1*, the District will refer the permit application to the Region Tech Center Bridge Lead and the Bridge Designer for their input and approval. Otherwise, the District Manager will simply approve, monitor the installation of the utility, and assure that all utility installations are labeled in accordance with accepted practices (see *BDM 1.25.1*).

(2) Region Tech Center Roles and Responsibilities

When the District forwards a copy of a utility permit request to the Region Tech Center for review prior to the issuance of the permit, the Regional Tech Center Bridge Lead and Bridge Designer will assure that the utility installation is in compliance with the items in *BDM 3.14.10.1-(3)* and *BDM 1.25.1*. Consult the Bridge Engineering Section when there are discrepancies. After review, return the permit application comments or approval to the District, who will monitor the utility installation.

For proposed utilities on historic bridges, have the application reviewed by the Region Cultural Resource Specialist.

(3) Bridge Engineering Section Roles and Responsibilities

The Bridge Engineering Section (Preservation, Operations/Inspection, or Load Rating, as applicable) will provide input if the utility installation will have a direct impact on any of the following:

- The installation is on a bridge that has a cathodic protection system in place, or is within a Marine/Coastal Environment as defined in *BDM 1.26*
- Installation has the potential to create a corrosive environment due to dissimilar materials
- The utility is going to be installed on a drawbridge
- The installation is in a confined space where its location or operation creates an unsafe environment for bridge inspection or bridge maintenance personnel
- The installation calls for the installation of a High-Voltage Line on a bridge (See *BDM 1.25.1*)
- The utility contains a high-pressure line or volatile gases
- The installation has the potential for adding a significant amount of dead load to the bridge or individual structural components (See *BDM 1.25.1*)

3.14.11 Railroad

Coordinate all site visits in which you will be on railroad right-of-way, or off railroad right-of-way but within 50' of the railroad track, with your Project Leader or Project Manager and the Utility & Railroad Coordinator. It is illegal to enter upon railroad right of way without proper permissions, PPE, and training.

3.14.11.1 Permits

If the bridge is over a railroad track, the Bridge Designer will be involved with providing information for the railroad permit applications.

Much of the information supplied for railroad permit applications by the Bridge Designer is in the form of drawings with specific data shown. TS&L Plan-and-Elevation drawings and vicinity maps are normally used as a basis for special permit drawings, but strip them of any information not needed to obtain the permit. Keep in mind: the people reviewing the applications are not structural designers. They do not have time to sift through many drawing details and dimensions not relevant to the permit approval.

3.14.11.2 Railroad Considerations

When scoping bridge repair work above or adjacent to the Union Pacific Railroad right-of-way, consider the following items that may be required:

1. A plan review by UPRR's engineering personnel in Omaha, Nebraska. Expect a thirty working day turnaround.
2. Crash wall addition. This would add approximately \$250,000 for each wall.
3. Drainage review.
4. Protective fencing.
5. UPRR will want reimbursement for their involvement in the preliminary review work.

UPRR standards require crash walls if a pier, foundation or abutment is within 25 feet of an existing or future track centerline. Protective fencing is required on all bridges. ODOT maintains its own drainage. UPRR acknowledges existing construction and maintenance agreements, and will consider this for each review. Minor repair work will not warrant the safety upgrades to the bridge. Consult the ODOT Utility & Railroad Coordinator early in the process for any bridge work that could trigger these requirements.

3.14.11.3 Railroad Clearances

Show project specific design clearances, construction clearances, and shoring clearances on the contract plans. Refer to *DET1200* which contains many of the required railroad crossing details.

Design Clearances – Clearances required for permanent construction over railroads are shown in the design guides provided by the railroads or on the railroad's website. See *BCM 7.3.8* and *Figure 7.3.8A*.

Shoring Clearances – Shoring clearances required for construction adjacent to railroads are shown in the design guides provided by the railroads or on the railroad's website.

A shoring diagram showing the proposed excavation relative to the tracks and all other pertinent information as detailed in the design guides.

Construction Clearances – Construction clearances required for construction over railroads are shown in the design guides provided by the railroads or on the railroad's website.

Show a construction clearance diagram similar to *Figure 3.14.11.3* on the plans.

Bridge Design Manual – June 2020
Oregon Department of Transportation
Section 3 – Processes & Roles

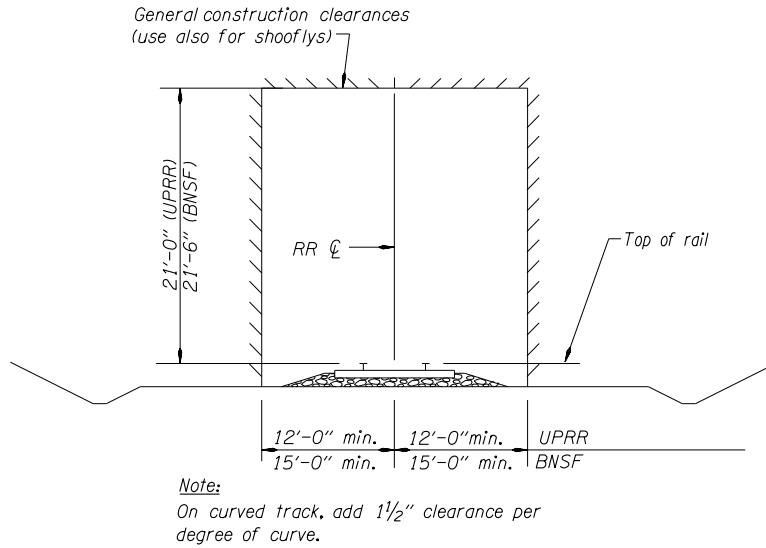

GENERAL RAILROAD CONSTRUCTION CLEARANCES

Figure 3.14.11.3

Note: All horizontal clearances shown are for tangent track. On curved track, increase the lateral clearances per AREA Specifications. For special cases, such as in yards, lesser clearances may be agreed to by the Railroad.

3.14.12 Public Involvement

See [PDLT Operational Notice PD-12](#).

[Reserved for future use. (Talk about possible need to prepare exhibits and provide info to the Project Leader, Project Manager, Bridge Design Manager, or PI folks for public presentations.)

APPENDIX – SECTION 3.4 – ROLES & RESPONSIBILITIES

[A3.4.1 Bridge Designer](#)

[A3.4.2 Bridge Design Reviewer](#)

[A3.4.3 Bridge Design Checker](#)

[A3.4.4 Bridge Subject Matter Expert](#)

[A3.4.5 Bridge Design Coordinator](#)

[A3.4.6 Bridge Quality Auditor](#)

A3.4.1 Bridge Designer

The purpose of the Bridge Designer is to design, engineer and ensure the utmost in quality of the Bridge deliverables prepared for publication, contract, or construction.

At Project Initiation (at least two weeks prior to the ‘kick-off’ meeting):

- Meet with and discuss the goals and objectives of the project and the bridge design with the Bridge Reviewer.
- Review the Bridge Design Work Order (for outsourced work also see the statement of work of A&E contract).
- Review project schedule.
- Know who is the assigned Bridge Checker.
- Prepare to attend the project kick-off meeting.

After the Project Initiation (kick-off) Meeting (0% DAP Design Phase):

- Prepare bridge design criteria and table of Bridge Design Standards
- Identify alternatives/options.
- Vet out each alternative/option to a point that can make decision to keep or drop.
- Prepare preliminary calculations, as needed.
- Start TS&L Narrative or TS&L Memo, estimates, plan sheets, design deviations/exceptions.

At 50% DAP Design Phase (~50% TS&L development):

- Meet with Bridge Reviewer (if not already doing); review the status of the design and the progress of the Alternatives Study (Are the right alternatives/options being studied? Are there other alternatives/options that should be included?), TS&L Narrative or TS&L Memo, plan sheet(s), engineer’s estimate, and design deviations/exceptions.
- Review Bridge Design Work Order / Statement of Work or Project Guide and ensure that the “problems/deficiencies” are actually getting addressed. (It is always easier to make corrections in the “path forward” when they are identified earlier than later!)

At 85% DAP Design Phase (95% TS&L development) thru DAP Milestone:

- Complete TS&L Report (TS&L Memo or Draft TS&L Narrative, plan sheet(s), and Engineer’s Estimate @ TS&L, Bridge Design Criteria & Standards Assessment, Design Deviations and Exceptions, and Alternatives Study) and submit to Bridge Reviewer for review.
- Receive written review comments from Bridge Reviewer. Prepare responses to review comments.
- Hold ‘sit-down’ with Bridge Reviewer and review responses to review comments. Reach consensus.
- Update TS&L Report.
- Complete Bridge Designer QC Form.
- Submit complete TS&L Report to Bridge Reviewer and Project Leader (for DAP).

After DAP is approved (0% Plan Development) thru Preliminary Plans Milestone (50% Plan Development):

- Start Final Design.
- Start Preliminary Plans package.
- Complete Final Design calculations.
- Prepare Preliminary Plans plan sheets to a 70% level of completion. Show the basic geometry of all major elements; do not have to show all detail necessary for bidding and construction.
- Prepare Engineer's Estimate @ Preliminary Plans.
- Create a special provision list (SPLIST is available to download at webpage of special provision templates) and identify applicable special provisions. (This is a good time to actually review the 100 sections, particularly SP110 and SP190. Understanding these sections can help complete quantities and other aspects of the package.)
- Submit Preliminary Plans package to Bridge Reviewer and Project Leader.
- Complete Bridge Designer QC Form.
- Start Advance Plans package.

After Preliminary Plans Milestone thru Advance Plans Milestone (90% Plan Development):

- Complete final design edits to calculations.
- Prepare Advance Plans plan sheets to a 99% level of completion. Show all geometry and details necessary for bidding and construction.
- Prepare Engineer's Estimate @ Advance Plans.
- Prepare special provisions (in some cases, this may be required to be completed at the Preliminary Plans milestone; check with Project Leader).
- Submit Advance Plans package to Bridge Reviewer, Bridge Checker and Project Leader.
- Answer questions from Bridge Checker and Bridge Reviewer and finalize design calculations plan sheets, special provisions and estimate.
- Receive written review comments from Bridge Checker and Bridge Reviewer. Prepare responses to review comments.
- Hold 'sit-down' with Bridge Checker and Bridge Reviewer and review responses to review comments. Reach consensus.
- Update Advance Plans package.
- Submit complete Advance Plans package to Bridge Checker.
- Submit complete Advance Plans package to Bridge Reviewer and Project Leader.
- Complete Bridge Designer QC Form.

After Advance Plans Milestone thru Final Plans Milestone (100% Final Design):

- Complete final Checking edits to calculations.
- Prepare Final Plans plan sheets to a 100% level of completion. Show all geometry and details necessary for bidding and construction.
- Prepare Engineer's Estimate @ Final Plans.
- Review special provisions package.
- Submit Final Plans package to Bridge Reviewer, Bridge Checker and Project Leader.
- Work with Bridge Checker, Bridge Reviewer and any others to resolve all review comments.
- Update Final Plans package.
- Submit complete Final Plans package to Bridge Checker.
- Submit complete Final Plans package to Bridge Reviewer and Project Leader.
- Complete Bridge Designer QC Form.
- Work with Bridge Reviewer to ensure all Bridge-related PD-02 Final PS&E Submittal Checklist requirements are complete.
- Work with Project Leader to ensure all PS&E package bridge deliverables are complete.

Bridge Design Manual – June 2020
Oregon Department of Transportation
Section 3 – Processes & Roles

After Final Plans Milestone thru PS&E Package Milestone:

- Complete Calculation Books to this point in time, pdf, and send pdf to Bridge Reviewer. (Keep original for use through construction.)
- Complete load rating.
- Work with Bridge Reviewer to ensure all bridge deliverables and Bridge Quality Documentation is complete.

After PS&E Package Milestone:

- Work with Project Leader to complete any bidding RFIs and Addenda Letters.
- Complete Cost Data information.
- Complete Bridge Inventory Forms.
- Provide Construction Support.
- Complete “constructed” calculation book (typically an amended design calc. book)
- Complete the “design” load rating.

A3.4.2 Bridge Reviewer

[Internal] = Internal to ODOT

[External] = External to ODOT; eg, A&E Consultant

The following duties are relevant to a Bridge Reviewer employed by ODOT [Internal]. For external Bridge Reviewer duties see the approved A&E Design Quality Plan for the specific project.

The purpose of the Bridge Reviewer is to review and ensure the utmost in quality of the Bridge Design deliverables prepared for publication, contract, or construction. The Bridge Reviewer shall have a background in bridge design commensurate to the work being reviewed.

Also, ODOT Bridge Reviewers should understand the different contracting methods for design and construction. They should understand Federal Aid, Federal participation, and Federal funding vs. State funding. They should understand “color of money” (funding) and how it affects the rules, regulations, and deliverables associated with the different contracting methods.

Throughout all design phases:

- Mentor bridge designers and checkers.

At Resource Planning Milestone [Internal only]:

- Review all STIP and Non-STIP projects for bridge work.
- Review pre- ‘Project Initiation’ project schedules (year, start, finish) for all STIP projects with bridge work.
- Review ODOT Project Business Case and Bridge Design Work Order for the anticipated type of bridge work/design. (If no Business Case (eg, a bridge through a program other than the Bridge Program), meet with Project Leader and Area Manager to discuss the nature of the structures work. Inform them that the purpose of this meeting is to better understand the work so the appropriate ‘level of experience’ can be made, and the Bridge Designer and Bridge Checker assigned.)
- Participate in assignment of Bridge Reviewer, Bridge Designer and Bridge Checker at BLT or other bridge design resource planning venue.

At Project Initiation Milestone (at least two weeks prior to the ‘kick-off’ meeting):

- Review Bridge Design Work Order (for outsourced work also see the statement of work of A&E contract).
- Confirm project schedule.
- Confirm assignment of Bridge Designer and Bridge Checker.
- Meet with and discuss the goals and objectives of the project and the bridge design with the Bridge Designer.
- After meeting with the Bridge Designer, complete the Bridge Reviewer QC/QA Checklist for Project Initiation.

At 50% Preliminary Design Phase:

- Check in with Bridge Designer (if not already doing); review the status of the design and the progress of the Alternatives Study (Are the right alternatives being studied? Are there other alternatives that should be included?), TS&L Memo or TS&L Narrative, Plan Sheet(s), Estimate, Design Criteria, Table of Bridge Design Standards, and Design Deviations. (This one time check-in is appropriate for a designer experienced in the type of design/work. If the designer has not designed this type of work, or has limited experience with this type of work, the Bridge Reviewer should be checking in on a more regular schedule (eg, monthly or weekly). (It is always easier to make corrections in the “path forward” when they are identified earlier than later!)
- For Bridge Program bridges, review ODOT Project Business Case and ensure that the “problems/deficiencies” are actually getting addressed.

Bridge Design Manual – June 2020
Oregon Department of Transportation
Section 3 – Processes & Roles

At 85% Preliminary Design Phase thru DAP Milestone:

- For Bridge Program bridges, review ODOT Project Business Case and ensure that the “problems/deficiencies” are addressed.
- Review Alternatives Study. (Have the right alternatives been studied? Is the recommended alternative the correct choice?)
- Review TS&L Memo or TS&L Narrative, Plan Sheet(s), Estimate, and Design Deviations. (Are all the alternatives in the study properly documented as to the rationale why 1) not selected as the recommended alternative, and 2) selected as the recommended alternative. Are design deviations approved by State Bridge Engineer?)
- Provide written review comments to Bridge Designer.
- Hold ‘sit-down’ with Bridge Designer and review responses to review comments. Reach consensus.
- Verify resolution of review comments (review updated documents against responses to review comments).
- Ensure Bridge Designer submits TS&L Report to Project Leader for use in DAP.
- Complete the Bridge Reviewer QC/QA Checklist for TS&L Report.

At Preliminary Plans Milestone:

- Review Preliminary Plans package against list of possible Bridge Plan drawings.
- Review Preliminary Plans. (have all sheets been started and drafted to 60~70% so Bridge Design Reviewer can see the ‘skeleton’ of the project coming together?)
- Ensure Bridge Designer submits Preliminary Plans deliverables to Project Leader for use in the Preliminary Plans review package.

At Advance Plans Milestone thru Final Plans Milestone:

- Review PS&E documents (the plans, the specifications / special provisions, the cost estimate, the estimate of construction duration) against 1) TS&L Report, 2) DAP Report, 3) BDM, 4) design codes, and 5) other applicable guidance.
 - Review against Geotechnical requirements.
 - Review against Hydraulic requirements.
 - Review against Environmental & Permitting requirements.
 - Review against Storm Water requirements. Ensure deck geometry is correct for satisfactory drainage of the bridge deck, and appropriate collection and transport of storm water away from the bridge and water body.
 - Review against Roadway geometrics (horizontal alignment, vertical alignment, superelevation, grades, deck elevations).
 - Review against design exceptions and design deviations.
 - Review against Survey topography (bridge length, width and height fits the contours of the existing and future (proposed) ground surface, foundations are at appropriate location).
 - Review against Right of Way (bridge is within limits of final right of way lines).
 - Review against Mobility requirements.
 - Review against Utility requirements.
 - Review against Railroad requirements.
 - Review against Public Involvement and Aesthetic requirements.
 - Review against Qualified Products List (QPL).
- Review against any revisions to these documents made during the Final Design Phase, and ensures changes are reflected in the Bridge PS&E documents.
- Review cost estimate for appropriate bid items, unit cost, and unit cost modifiers (quantities checked by Bridge Checker).
- Review estimate of probable construction durations. Ensures logical and of appropriate duration for assumed method of construction.
- Review that all reference special provisions are included for applicable project special provisions.
- Review changes to special provisions, other than ‘fill in the blank’ changes, are appropriate and adequate.
- Review that design and detailing practices used meet standards; or that rationale to deviate from standard is appropriate.

Bridge Design Manual – June 2020
Oregon Department of Transportation
Section 3 – Processes & Roles

- Review that details are consistent between bridges on projects with multiple bridges; or that rationale for different details between bridges is appropriate.
- Review deliverables against project's funding requirements. Ensure the requirements associated with that "color of money" are completed.
- Provide written review comments to Bridge Designer.
- Hold 'sit-down' with Bridge Designer and review responses to review comments. Reach consensus.
- Verify resolution of review comments (review updated documents against responses to review comments).
- Ensure Bridge Designer submits Advance Plans deliverables to Project Leader for use in the Advance Plans review package.
- Ensure Bridge Designer submits Final Plans deliverables to Project Leader for use in the Final Plans package.
- Complete the Bridge Reviewer QC/QA Checklist for these milestones.

At PS&E Package Milestone:

- Verify that all review comments are resolved and closed out.
- Ensure Bridge-related PD-02 Final PS&E Submittal Checklist requirements are complete and coordinate with Bridge Designer, Project Leader, and OPL Quality Engineer (if necessary) before submitting PS&E package.
- Ensure Bridge Designer submits PS&E deliverables to Project Leader for use in the PS&E Package.
- Ensure all Bridge Design Quality Documents are complete and submitted.
- Complete the Bridge Reviewer QC/QA Checklist and submit to Bridge Design Manager and Bridge Operations & Standards Manager.

A3.4.3 Bridge Design Checker

The purpose of the Bridge Checker is to perform a “Quality Check” of the structural design.

At Project Initiation (at least two weeks prior to the ‘kick-off’ meeting):

- No action.

After the Project Initiation (kick-off) Meeting (0% Preliminary Design Phase):

- No action.

At 50% Preliminary Design Phase:

- No action.

At 85% Preliminary Design Phase thru DAP Milestone:

- No action.

After DAP is approved (0% Final Design) thru Preliminary Plans Milestone (50% Final Design):

- No action.

After Preliminary Plans Milestone thru Advance Plans Milestone (90% Final Design):

- No action.

At Advance Plans Milestone thru Final Plans Milestone (100% Final Design):

- Receive Advance Plans package.
- For Class III checks, receive pdf’s of all non-structural calculations and perform independent checks.
- For Class II checks, receive pdf of structural calculations to use to perform a ‘line-by-line’ check.
- For Class I checks, start to prepare independent calculations.
- Check plan sheets.
- Check quantities and cost estimate.
- Check estimate of probable construction schedule.
- Check special provisions.
- Complete calculations check.
- Provide written review comments to Designer.
- Hold ‘sit-down’ with Designer and review responses to review comments. Reach consensus.
- Verify resolution of review comments (review updated documents against responses to review comments).
- Complete Checker QC Checklist.

At PS&E Package (100% Final Design):

- When changes are made, check updated Special Provisions and revisions after OPC review.

A3.4.4 Bridge Subject Matter Expert

The purpose of the Bridge Subject Matter Expert (as it relates to the design of a project) is to ensure design standards and boilerplate special provisions are complete and up-to-date for the type of bridge work being designed and constructed today. The SME is also a reference to the Designer, Checker, Reviewer and others throughout the entire cycle of bridge design, construction, inspection and maintenance of the State's bridge inventory. The SME also provides training (one-on-one, one-on-many, external provider, etc) as needed.

During development of a project:

Before a project even exists:

- Provide technical guidance during maintenance, deficiency identification, and project scoping as requested.
- Assist Bridge Program Manager to identify reasonable and feasible alternatives/options for Alternatives Study.

At Project Initiation (at least two weeks prior to the 'kick-off' meeting):

- Typically no action.

After the Project Initiation (kick-off) Meeting (0% Preliminary Design Phase):

- Typically no action.

At 50% Preliminary Design Phase:

- Provide technical guidance as requested.

At 85% Preliminary Design Phase thru DAP Milestone:

- Review and provide comments to Designer (with copy to the Reviewer).

After DAP is approved (0% Final Design) thru Preliminary Plans Milestone (50% Final Design):

- Provide technical guidance as requested.
- Review and provide comments to Designer (with copy to the Reviewer), as requested.

After Preliminary Plans Milestone thru Advance Plans Milestone (90% Final Design):

- Provide technical guidance as requested.
- Review and provide comments to Designer (with copy to the Reviewer and Checker), as requested.

At Advance Plans Milestone thru Final Plans Milestone (100% Final Design):

- Typically no action.

At PS&E Package (100% Final Design):

- Typically no action.

After a project is let and construction is complete:

- Provide technical guidance during inspection and maintenance as requested.

Outside development of a project:

- See BPPM for details.

A3.4.5 Bridge Design Coordinator

The purpose of the Bridge Design Coordinator is to track, pursue, and ensure all Bridge Quality Documentation is received from Regions/Reviewers, and to ensure this data is entered, stored, retained, and managed in the utmost professional manner.

During development of a project:

At Resource Planning Milestone:

- Receive list of all STIP and Non-STIP projects with bridge work from Bridge Program Manager. (These are the 'lion's share' of the projects to track and collect data.)

At Project Initiation (at least two weeks prior to the 'kick-off' meeting):

- No action.

After the Project Initiation (kick-off) Meeting (0% Preliminary Design Phase):

- No action.

At 50% DAP Design Phase:

- No action.

At 85% DAP Design Phase thru DAP Milestone:

- Receive pdf of TS&L Report and pdf of Reviewer's review package (data and review comment form) from Reviewer.
- Store in Bridge EDMS.

After DAP is approved (0% Plan Development) thru Preliminary Plans Milestone (50% Plan Development):

- Receive pdf of Preliminary Plans package and pdf of Reviewer's review package (data and review comment form) from Reviewer.
- Store in Bridge EDMS.

After Preliminary Plans Milestone thru Advance Plans Milestone (90% Plan Development):

- Receive pdf of Advance Plans package and pdf of Reviewer's review package (data and review comment form) from Reviewer.
- Store in Bridge EDMS.

At Advance Plans Milestone thru Final Plans Milestone (100% Plan Development):

- Receive pdf of Final Plans package and pdf of Reviewer's review package (data and review comment form) from Reviewer.
- Store in Bridge EDMS.

At PS&E Package (100% Plan Development):

- Receive pdf of PS&E Package and pdf of Reviewer's review package (data and review comment form) from Reviewer.
- Store in Bridge EDMS.

After PS&E Package:

- Receive the Reviewer's QC/QA Checklist for each project.
- Complete EDMS QC Checklist.

Outside development of a project:
See BPPM for details.

A3.4.6 Bridge Quality Auditor

The purpose of the Bridge Quality Auditor is to ensure design processes and standards were followed or that appropriate design deviations and exceptions were prepared to document why design processes and standards were not followed.

During development of a project:

At Project Initiation (at least two weeks prior to the 'kick-off' meeting):

- No action.

After the Project Initiation (kick-off) Meeting (0% Preliminary Design Phase):

- No action.

At 50% Preliminary Design Phase:

- No action.

At 85% Preliminary Design Phase thru DAP Milestone:

- No action.

After DAP is approved (0% Final Design) thru Preliminary Plans Milestone (50% Final Design):

- No action.

After Preliminary Plans Milestone thru Advance Plans Milestone (90% Final Design):

- No action.

At Advance Plans Milestone thru Final Plans Milestone (100% Final Design):

- No action.

At PS&E Package (100% Final Design):

- No action.

After PS&E Package:

- Receive the Reviewer's QC/QA Checklist for each project.
- On a 'to-be-determined' schedule, identify 'X' projects per year to perform a Quality Audit.
- Perform Quality Audit.
- Prepare report of findings.
- Hold 'sit-down' meeting with State Bridge Engineer, Bridge Design Manager to go over findings.
- Receive some form of assurance that findings will be addressed.
- Complete Auditor QC Checklist.

Outside development of a project:

- See BPPM for details.

APPENDIX – SECTION 3.5 – QUALITY

The following forms are posted on the [ODOT Bridge website](#):

[Bridge Designer QC Form](#)

[Bridge Reviewer QC/QA Checklist](#)

[Bridge Checker QC Form](#)

[Bridge Preservation QC/QA Form](#)

[Bridge Audit QC Report](#)

[Bridge EDMS QC Checklist](#)

[Bridge Drafter QC Checklist for TS&L Plan Sheet\(s\)](#)

[Bridge Drafter QC Checklist for Advance Plans \(95%\) Plan Sheet\(s\)](#)

BRIDGE EDMS QC CHECKLIST

[Under development]

BRIDGE DRAFTER QC CHECKLIST FOR TS&L PLAN SHEET(S)

See *BCM*.

BRIDGE DRAFTER QC CHECKLIST FOR ADVANCE PLANS (95%) PLAN SHEETS

See *BCM*.

APPENDIX – SECTION 3.91 – METRIC CONVERSION

[A3.91.1 Introduction](#)

[A3.91.2 Basic Units](#)

[A3.91.3 Derived Units](#)

[A3.91.4 Metric Conversion Factors](#)

[A3.91.5 Metric Procedural Rules](#)

[A3.91.6 Bridge Plan and Preparation Guidelines](#)

[A3.91.7 Miscellaneous Common Conversions](#)

A3.91.1 Introduction

The International System of Units (SI), a modern version of the metric system of measurement, is being adopted throughout the world. To remain competitive in the global economy, Congress determined the United States must convert to SI.

FHWA was planning to require ODOT and local agencies to submit contract documents in metric by September 30, 1996. Congress then postponed the implementation date to September 30, 2000 and later completely removed the requirement.

After removal of the Metric requirement, most states have reverted back to English units or dual units.

ODOT believes it is important to be in alignment with other state DOT's and local government partners. ODOT began converting back to English units in late 2002 and began contracting State projects in English units in early 2004.

This section has been retained to provide a guide to the units and conversions most commonly used by the Bridge Engineering Section during the Metric era. This section may help with the interpretation of plans produced during the Metric era.

A3.91.2 Basic Units

There are five metric "basic units" that concern bridge design and construction (see Figure 3.91.2).

BASIC ODOT BRIDGE DESIGN METRIC UNITS

Quantity	Unit	Symbol
Length	Meter	m
Mass	Kilogram	kg
Time	Second	s
Temperature	Celsius	°C
Plane angles	degree, minute, second	0°, 0', 0"

Figure 3.91.2

3.91.2.1 Decimal Prefixes

Many numbers resulting from metric calculations are too large or small to be practically used. Three decimal prefixes are commonly used with the base units to produce manageable numbers (see Figure 3.91.2.1).

DECIMAL PREFIXES

Prefix	Symbol	Magnitude	Expression
Mega	M	10 ⁶	1 000 000 (one million)
Kilo	k	10 ³	1000 (one thousand)
Milli	m	10 ⁻³	0.001 (one thousandth)

Figure 3.91.2.1

A3.91.3 Derived Units

In addition to the five basic units, there are three metric units derived from the basic units that are used frequently in structural calculations (see Figure 3.91.3).

DERIVED UNITS

Quantity	Name	Symbol	Expression
Force	Newton	N	N = kg•m/s ²
Pressure, stress	Pascal	Pa	Pa = N/m ²
Energy	Joule	J	J = N•m

Figure 3.91.3

3.91.3.1 Force

In order to perform metric calculations properly, it is important to understand the distinction between mass "kg" and force "N".

In the metric system, there are separate units for mass "kg" and force "N". Mass indicates the quantity of matter in an object. Force or "force of gravity" is the acceleration due to gravity the object experiences in a particular environment. The mass must be converted to force before computing structural reactions, shears, moments, or internal stresses. Force "N" = mass times acceleration due to gravity. The metric acceleration of gravity on the earth's surface is 9.807 m/s² (i.e., 32.2 ft/s² x 0.3048 m/ft). One newton = one kilogram x (one meter)/(one second)².

For example, a simply supported beam 10 meters long with a mass of 1000 kg/m would have a total mass of 10 000 kg (see Figure 3.91.3.1). However, the dead load or force on a beam, on the earth's surface, used to calculate the reactions, shears, moments, etc. would be 1000 x 9.807 = 9807 N/m. The distinction between mass and force in structural calculations is very important.

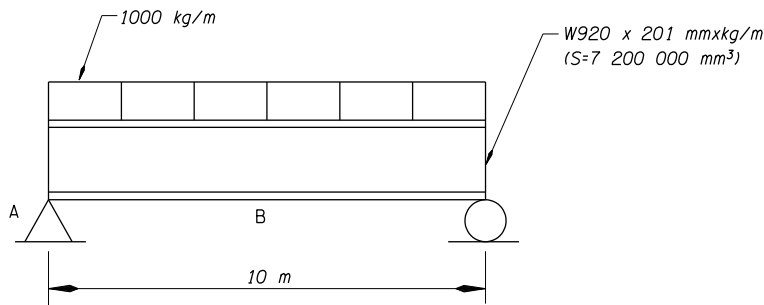

Quantity	Inch-Pound Units	Metric Units
Dead Load (Force)	= 672+135 = 807 lb/ft	= (1000+201) (9.807) = 11 777.8 N/m
$V_A = wl/2$	= (807)(32.808)/2 = 13,238 lb	= (11 777.8) (10)/2 = 58 889 N
$M_B = wl^2/8$	= (807)(32.808) ² /8 = 108,578 ft-lb	= (11 777.8)(10) ² /8 = 147 222 N•m
$F_B = M/s$	= (108,578)(12in/ft)/440 = 2961 psi	=(147 222)(10 ⁹ mm ³ /m ³)/7210x10 ³ = 20 419 000 Pa = 20 419 kPa = 20.419 MPa

Note: lb is understood to be lb-force.

Figure 3.91.3.1

3.91.3.2 Stress

The pascal is not universally accepted as the only unit of stress. Because steel section properties are expressed in millimeters, it may be more convenient to express stress in a derivative of pascals; that is in newtons per square millimeter (1 N/mm² = 1 MPa).

3.91.3.3 Energy

Although the joule is a standard metric unit, it is typically not used in structural design. Moments are always expressed in terms of Nm, or the derivative kN•m.

A3.91.4 Metric Conversion Factors

Figure 3.91.4, is intended to provide common conversion factors and show typical equivalent conversion units between "inch-pound" and "metric" values. The factors will allow the designer to get a feel for the magnitude of metric units as compared to inch-pound units.

COMMON METRIC UNITS AND CONVERSIONS

Quantity	From Inch-Pound Units	To Metric Units	Multiply by
Length	mile	km	1.609 344
	foot	m	0.304 8
	inch	mm	25.4
Area	square mile	km ²	2.590 00
	acre	m ²	4 046.87
	square yard	m ²	0.836 127 4
	square foot	m ²	0.092 903 0
	square inches	mm ²	645.160
Volume	cubic yard	m ³	0.764 555
	cubic foot	m ³	0.028 316 8
Mass*	Lb	kg	0.453 592
	Ton	kg	0.907 184
Mass/unit length*	Plf	kg/m	1.488 16
Mass/unit area*	Psf	kg/m ²	4.882 43
Mass density*	Pcf	kg/m ³	16.018 5
Force	Lb	N	4.448 22
	metric kg	kN	9.806 65
	kip	kN	4.448 22
Force/unit length	Plf	n/m	14.593 9
	Klf	kN/m	14.593 9
Pressure, stress, Modulus of elasticity	Psf	Pa	47.880 3
	ksf	kPa	47.880 3
	psi	kPa	6.894 76
	ksi	MPa	6.894 76
Bending moment, torque, moment of force	ft-lb	N•m	1.355 82
	ft-kip	kN•m	1.355 82
Moment of inertia	in ⁴	mm ⁴	416 231
Section modulus	in ³	mm ³	16 387.064
Temperature	°F	°C	5/9 (°F - 32)

*Note: The Inch-Pound Units system using "a mass which weighs such and such pounds" and converting to true Metric Units masses.

Figure 3.91.4

A3.91.5 Metric Procedural Rules

3.91.5.1 Writing Metric Symbols and Names

- Unit symbols should be in lower case except for newton (N), pascal (Pa), and mega (M).
- Unit names should always be printed in lower case, i.e., newton, pascal, kilogram.
- Do not use the plural of unit symbols (write 45 kg, not 45 kgs), but do use the plural of written unit names (several kilograms).
- Leave a space between the numeral and a unit symbol. Write "70 kg" or "30 °C", not "70kg" or "30°C".
- Do not use a period after the symbol. Write "70 kg", not "70 kg.", except when it comes at the end of a sentence.
- Indicate the product of two or more units in symbolic form by using a dot between the symbols, i.e., N•m or kg•m.
- Do not mix names and symbols. Write N•m or newton meter, not N•meter or newton•m.
- Do not leave a space between a decimal prefix and a unit symbol. Write "MPa" or "kN•m", not "M Pa" or "k N•m".

3.91.5.2 Writing Numbers

- Use decimals, not fractions. Write 0.75 m, not 3/4 m.
- Use a zero before the decimal point for values less than one. Write 0.65 kg, not .65 kg.
- Spaces are frequently used to separate blocks of three digits either side of the decimal point. Never use a comma to separate the blocks. For plan dimensions, it will be acceptable to either insert or omit the space. Write 16 387.064 or 16387.064; but never 16,387.064.

3.91.5.3 Conversions and Rounding

When converting from inch-pound units to metric units, round the metric value to the same number of digits as there were in the inch-pound number, i.e., $235.75 \text{ lb} \times 0.453 592 \text{ kg/lb} = 106.9343 \text{ kg}$ which should be rounded to 106.93 kg.

Also see *ASTM E380*, Section 5, for general guidelines.

A3.91.6 Bridge Plan and Preparation Guidelines

3.91.6.1 Plan Dimensions

For dimensions and elevations use:

- Millimeters in standard drawings and structural details.
- Meters for plan dimensions (structure and span lengths, structure width, lane and shoulder widths,

etc.) and other long dimensions.

- Meters to three places for elevations, preceded with the abbreviation El. (e.g., El. 309.564).

To eliminate the repetitive use of (mm) and (m), these will not be used for dimensions in millimeters and elevations in meters. Meter dimensions should be followed by the symbol (m).

The following note should be shown on the plans, "All dimensions are in millimeters (mm) and all elevations are in meters (m), except as noted."

At all locations in notes, etc. use (mm) and (m) notations.

3.91.6.2 Reinforcing Steel

A new series of soft converted reinforcing steel sizes should be used. Figures 3.91.6.2A and 3.91.6.2B on the following page show the metric properties for conventional and prestressing steel. The equivalent area in square inches is shown for comparison purposes. The metric bar size is roughly equal to the bar diameter in millimeters.

The length of straight bars should be shown in 100 millimeter increments where possible. Bent bars should be detailed to the nearest 20 millimeter total length.

3.91.6.3 Fasteners

Fasteners are to be called out as a soft conversion to the nearest 0.1 mm. Use the appropriate English specifications for bolts, nuts and washers.

3.91.6.4 Structural Steel

The structural steels called out in ODOT plans and specifications all have metric equivalents. These equivalent specifications have the same number (AASHTO or ASTM) followed by a capital M; e.g. AASHTO M 270M or ASTM A 709M.

Structural steel shapes will be a soft conversion. AISC conversion tables are available.

Plate thickness should be a soft conversion and called out to the nearest 0.1 mm.

Normally plate widths should be a hard metric conversion. In some situations it may be appropriate to use soft converted plate widths. If repetitious pieces have a dimension that can use a common English plate width, one plate cut can be avoided and it will be more economical to fabricate the item.

REINFORCING BAR COMPARISON

Metric Bar	English Bar	English Dia. (in)	English Area (in ²)	English Weight (lb/ft)	Metric Dia. (mm)	Metric Area (mm ²)	Metric Mass (kg/m)
#10	#3	0.375	0.11	0.376	9.5	71	0.560
#13	#4	0.500	0.20	0.668	12.7	129	0.994
#16	#5	0.625	0.31	1.043	16.0	199	1.552
#19	#6	0.750	0.44	1.502	19.1	284	2.235
#22	#7	0.875	0.60	2.044	22.2	387	3.042
#25	#8	1.000	0.79	2.670	25.4	510	3.973
#29	#9	1.128	1.00	3.400	28.7	645	5.060
#32	#10	1.270	1.27	4.303	32.3	819	6.404
#36	#11	1.410	1.56	5.313	35.8	1006	7.907
#43	#14	1.693	2.25	7.650	43.0	1452	11.38
#57	#18	2.257	4.00	13.60	57.3	2581	20.24

Figure 3.91.6.2A

Stock Bar Lengths

- #10 – 6.09 and 12.19 m
- #13 & # 16 – 6.09, 9.14 and 12.19 m
- #19 thru #36 – 18.28 m
- #43 thru #57 – 18.28, 21.33 and 24.38 m

PRESTRESSING STEEL - Conversion of prestressing steel should be a soft conversion using the table below. Make sure standard drawings and plan detail sheets specify the correct strand diameters.

SEVEN WIRE, UNCOATED STRAND

(270 Grade Low-Relaxation AASHTO M203 (ASTM A-416))

Metric Size (mm)	English Size (inch)	Metric Ult. (kN)	English Ult. (lbs)	Metric Area (mm ²)	English Area (in ²)	Metric Mass (kg/m)	English Weight (lb/ft)
9.53	3/8	102.3	23,000	54.84	0.085	0.432	0.290
11.11	7/16	137.9	31,000	74.19	0.115	0.582	0.390
12.70	1/2	183.7	41,300	98.71	0.153	0.775	0.520
15.24	0.600	260.7	58,600	140.0	0.217	1.102	0.740

Figure 3.91.6.2B

Bridge Design Manual – June 2020
Oregon Department of Transportation
Section 3 – Processes & Roles

A3.91.7 Miscellaneous Common Conversions

	Inch-Pound	Metric
Dead Loads:		
Future Wearing Surface	25 psf	1.2 kN/m ²
Reinforced Concrete	150 pcf	23.6 kN/m ³
Soil	120 pcf	18.9 kN/m ³
Material Strengths:		
Concrete (f'c)	3300 psi	22.8 MPa, Equiv. to 25 MPa
	4000 psi	27.6 MPa, Equiv. to 30 MPa
	4500 psi	31.0 MPa, Equiv. to 35 MPa
	5000 psi	34.5 MPa, Equiv. to 35 MPa
	5500 psi	37.9 MPa, Equiv. to 40 MPa
	6000 psi	41.4 MPa, Equiv. to 45 MPa
	6500 psi	44.8 MPa, Equiv. to 45 MPa
	7000 psi	48.3 MPa, Equiv. to 50 MPa
Reinforcing Steel:		
Grade 40	40 ksi	275.8 MPa, Equiv. to 300 MPa
Grade 60	60 ksi	413.7 MPa, Equiv. to 420 MPa
Grade 80	80 ksi	551.6 MPa, Equiv. to 550 MPa
Structural Steel:		
Grade 36	36 ksi	248.2 MPa, Equiv. to 250 MPa
Grade 50	50 ksi	344.7 MPa, Equiv. to 345 MPa
Grade 70	70 ksi	482.6 MPa, Equiv. to 480 MPa
Reinforcing Steel Clearances		
	1.0 in	25 mm
	1.5 in	40 mm
	2.0 in	50 mm
	2.5 in	65 mm
	3.0 in	75 mm
	4.0 in	100 mm
Aggregate sizes		
	1-1/2 in	37.5 mm
	1 in	25.4 mm
	3/4 in	19.0 mm
	3/8 in	9.5 mm
Deck Concrete		
	4500 psi	Equivalent to Class 30 (4350 psi)
End Panel Concrete		
	3300 or 4500 psi	Equivalent to Class 25 (3626 psi) or 30 (4350 psi)
Minor Structure Concrete		
	3000 psi	Class 20 (2901 psi)