

**Table of Contents**

**2.1 Section 2 – Introduction..... 2**

**2.2 Accelerated Bridge Construction (ABC) Guidelines..... 3**

2.2.1 Introduction..... 3

2.2.2 ODOT encourages and supports ABC Projects..... 4

2.2.3 Contracting Methods Allowed..... 4

2.2.4 Decision Making Framework..... 5

2.2.5 Analytic Hierarchy Process (AHP) Tool..... 8

2.2.6 Steel Structures..... 12

2.2.7 Concrete Structures..... 12

2.2.8 Full Depth Deck Panels, Approach Slabs or Approaches and Wingwalls..... 12

2.2.9 Precast Connections in Seismic Regions..... 12

2.2.10 Use of Self-Propelled Modular Transporters (SPMT)..... 15

2.2.11 Geotechnical Considerations..... 15

2.2.12 Accelerated Embankment Construction..... 17

2.2.13 QA/QC, Quality Control for Prefabricated Concrete Elements..... 18

2.2.14 Cost Considerations..... 20

2.2.15 Listing of bridges replaced using ABC techniques:..... 21

**2.3 Structure Appearance and Aesthetics ..... 23**

2.3.1 General..... 23

2.3.2 Location and Surroundings..... 24

2.3.3 Horizontal and Vertical Geometry..... 24

2.3.4 Superstructure Type and Shape..... 25

2.3.5 Bent Shape and Placement..... 25

2.3.6 End Bent Shape and Placement..... 25

2.3.7 Parapet and Railing Details..... 26

2.3.8 Colors..... 26

2.3.9 Textures..... 26

2.3.10 Ornamentation..... 27

**2.4 Bridge Types & Selection Guidance ..... 28**

2.4.1 Bridge Types and Economics..... 28

2.4.2 Substructure Guidance..... 31

2.4.3 Special Considerations for Federal-Aid Projects..... 31

2.4.4 Use of Salvage Materials..... 33

**2.5 Bridge Layout ..... 34**

2.5.1 Site Constraints..... 34

2.5.2 Spans and Proportions..... 34

2.5.3 Bridge Length..... 36

2.5.4 Substructure Guidance..... 36

**2.6 Safety and Accessibility Requirements..... 37**

2.6.1 Uniform Accessibility Standards..... 37

2.6.2 Inspection and Maintenance Accessibility..... 38

**2.7 Bridge Security Design Considerations ..... 40**

2.7.1 Bridge Security Design Considerations..... 40

2.7.2 Placing Buildings Beneath ODOT Bridges..... 42

**2.8 Bridge Name Plates & Markers ..... 44**

2.8.1 Existing Bridge Name Plates..... 44

2.8.2 Bridge ID Markers..... 44

Note: Revisions for **May 2020** are marked with **yellow highlight**. Deleted text is not marked; past editions of the BDM are available for comparison.

### 2.1 SECTION 2 – INTRODUCTION

*BDM Section 2* for design guidance pertinent to highway bridges and structures design.

See *BDM Section 1* for standards and practices pertinent to design of highway bridges and structures.

See *BDM Section 3* for standards and practices pertinent to design procedures and quality processes for completing highway bridge and structure design.

### 2.2 ACCELERATED BRIDGE CONSTRUCTION (ABC) GUIDELINES

#### [2.2.1 Introduction](#)

#### [2.2.2 ODOT encourages and supports ABC Projects](#)

#### [2.2.3 Contracting Methods Allowed](#)

#### [2.2.4 Decision Making Framework](#)

#### [2.2.5 ABC – Decision and Economic Modeling Analysis Tool using the Analytic Hierarchy Process \(AHP\)](#)

#### [2.2.6 Steel Structures](#)

#### [2.2.7 Concrete Structures](#)

#### [2.2.8 Full Depth Deck Panels, Approach Slabs or Approaches and Wingwalls](#)

#### [2.2.9 Precast Connections in Seismic Regions](#)

#### [2.2.10 Use of Self-Propelled Modular Transporters \(SPMT\)](#)

#### [2.2.11 Geotechnical Consideration](#)

#### [2.2.12 Accelerated Embankment Construction](#)

#### [2.2.13 QA/QC, Quality Control for Prefabricated Concrete Elements](#)

#### [2.2.14 Cost Considerations](#)

#### [2.2.15 Listing of bridges replaced using ABC techniques](#)

### **[2.2.1 Introduction](#)**

Oregon has a long history of employing ABC methods to quickly deliver bridge projects using a variety of techniques. Some were assembled or erected on temporary falsework located adjacent to an existing structure and skidded into place. This method allowed contractors to close the facilities to vehicular traffic for a relatively short time (a few days or weekend) and skid the bridge over after quickly demolishing the existing bridge at night and working through weekends. Other bridges over navigable waterways were replaced using barges to float new and whole superstructures into place (also known as switch out when an existing structure is replaced). For wider structures that can accommodate staged construction, precast concrete or concrete filled steel grid deck panels were installed using a partial closure of the roadway during off peak travel times.

A few Oregon ABC projects were designed with rapid construction in mind to limit traffic interruptions, but most were selected either based on VE proposals by contractors, incentive/disincentive provisions, or design-build contracts. Generally, the project schedules specified a relatively short window for closing or disrupting traffic operations on the facilities. The incentive/disincentive provision for each project was normally based on user delay costs as a function of AADT, detour length and other variables. Those projects have demonstrated ABC as an effective and efficient solution to alleviate congestion and/or long detours where conventional methods such as off-site detour, on-site detour, stage construction or slight realignment of the roadway were difficult or not feasible. They also resulted in improved public safety

through a shortened work zone exposure.

### **2.2.2 ODOT encourages and supports ABC Projects**

ABC methods can be defined as using prefabricated bridge elements, combining elements into systems, or moving a complete bridge span to quickly deliver a project and re-open a highway to traffic. Use of any of these methods are encouraged and supported by ODOT. A compiled list of past Oregon projects that described the ABC featured elements is provided here at the end of the Section for reference.

Construction activity results in delays to the public and incurs additional financial burdens on the people who must contend with the effects. This essentially results in a temporary tax on the affected neighborhood. Because of this, consider ABC methods even when it does not result in the lowest overall construction cost. Designers are encouraged to consider traffic delay costs and other user costs associated with a project to support stronger consideration of ABC methods. The ABC AHP Decision Making Program presented in *BDM 2.2.5* is available to assist in developing support for ABC.

Prefabricated elements consisting of deck panels, beams or girders, bent caps, pier columns and segments have been demonstrated successfully. Systems may consist of bridge components assembled and connected together to form a major portion or complete bridge span. Bridge movements such as incremental launching, skidding, and/or transport by self-propelled modular transporters (SPMT) of a partial/complete superstructure span are also found to be acceptable methods of construction. The guidance provided here will help designers and owners decide when and where ABC is appropriate as a method of project delivery. Although the Engineer on Record is responsible for the design as well as for developing a unique method of construction/movement to fulfill ABC requirements, the owner needs to be assured that quality and durability is not being compromised by the specific rapid construction technique being considered.

### **2.2.3 Contracting Methods Allowed**

A contract for specifying ABC method of delivery is allowed and will continued to be allowed under the current design-bid-build specifications. A contractor may propose an alternate method of construction for approval by the EOR/owner as part of the Cost Reduction Proposal provisions in *SP 00140.70* of the Oregon Standard Specifications for Construction. The third option allowing ABC is provided under the design-build contract provisions. More discussions and guidance are provided elsewhere and will not be elaborated here.

2.2.4 Decision Making Framework

A successful ABC project is dependent on deciding correctly at the beginning of a project planning to assess when and where ABC would be most efficient and effective. The following criteria in the flowchart, *Figure 2.2.4*, for specifying a short window of closure may make ABC delivery the method of choice:

ODOT Flowchart for Determining the Applicability of ABC

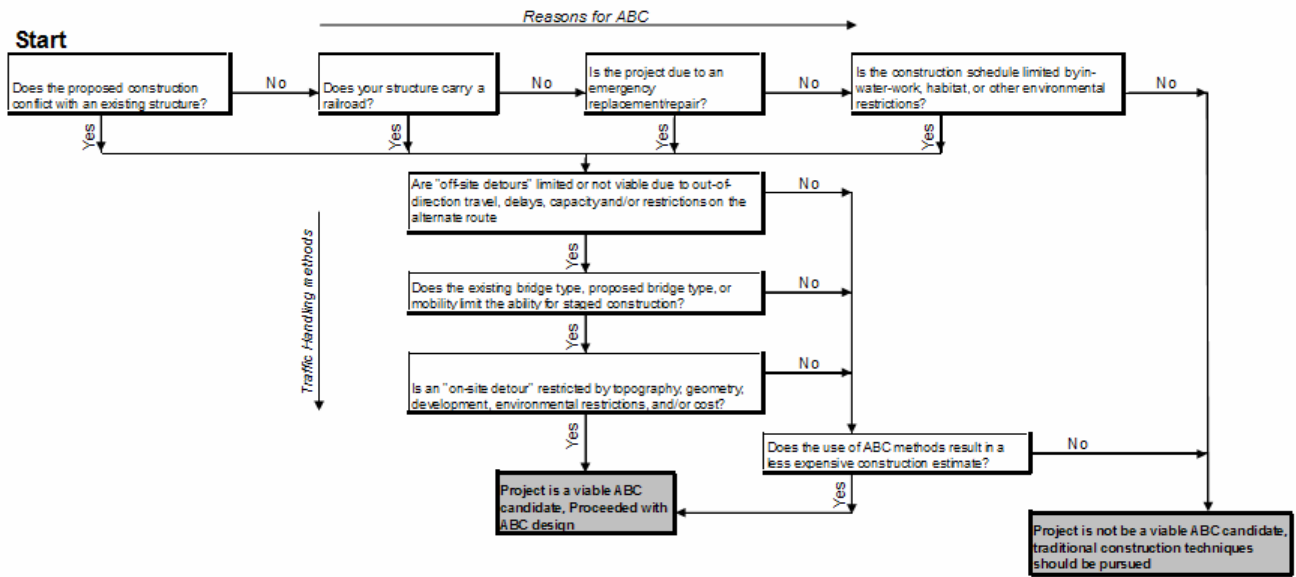

Figure 2.2.4

The following matrix is intended to help guide discussions when comparing ABC with conventional construction:

<b>ATTRIBUTES</b>	<b>Accelerated BC (ABC)</b>	<b>Conventional BC (CBC)</b>
1. Complexity	<ul style="list-style-type: none"> <li>-Engineer less familiar with design required for accelerated bridge construction techniques</li> <li>-May require more surveys to establish control points</li> <li>-May require pick points for prefabricated bridges</li> <li>-May require more complex construction techniques</li> <li>-May need new specs</li> <li>-May add risk to Contractor</li> <li>-May require special equipment</li> <li>-Good with D/B and A+B with incentive/disincentive</li> </ul>	<ul style="list-style-type: none"> <li>-Engineer more familiar with design required for conventional construction techniques; therefore, considered less complex.</li> <li>- Contractors more familiar with methods used in conventional construction, therefore considered less complex</li> <li>-Standard specs exists</li> </ul>
<b>ATTRIBUTES cont.</b>	<b>Accelerated BC (ABC) cont.</b>	<b>Conventional BC (CBC) cont.</b>
2. Schedule	<ul style="list-style-type: none"> <li>-Facility to reopen for traffic in hours or over weekends</li> <li>-Slightly longer design schedule due to complexity (see above)</li> <li>-Need more overall planning and coordination</li> <li>-Parallel construction off CPM</li> <li>-Typically can be done off-line and shorter field erection season, pending ABC method chosen.</li> <li>-Approach or utility work may control schedule if not outside CPM</li> <li>-Good with incentive/disincentive</li> <li>-Constructible connection details for precast elements such as bent caps, footings &amp; pile heads require flexibility for field closure pours.</li> <li>-May require coordinated demolition plan for change-over structures</li> <li>-May require tight control of scheduling on critical items</li> <li>-The contract plan or designed details should be simple or the precast element detail may not fit.</li> <li>-May require industry participation in PBES/ABC to ensure successful transition to field application.</li> <li>-Include contractor on design or constructability review team.</li> </ul>	<ul style="list-style-type: none"> <li>- Typical field construction season in months or years</li> <li>-Typical design schedule</li> <li>-Often bridge work is controlling in CPM</li> <li>-Sequential activities typical and limitations may exist</li> <li>-Public delay cost may be high</li> </ul>
3. Budget	<ul style="list-style-type: none"> <li>-May be more expensive in construction cost due to non-typical construction methods</li> <li>-May increase design cost</li> <li>-Limited historical bid item data</li> </ul>	<ul style="list-style-type: none"> <li>-Typical estimate given condition and conventional required structure type.</li> <li>-Typical standard project costs.</li> <li>-Incentives and disincentives may be included to accelerate construction and</li> </ul>

	<ul style="list-style-type: none"> <li>-ABC can significantly reduce the costs to highway users associated with traffic queues and detours during the bridge installation.</li> <li>-The contract bid cost for an ABC project may be more than a conventional bridge project but overall may be much less when the savings due to reduced traffic impacts and delays are factored in.</li> </ul>	<ul style="list-style-type: none"> <li>reduce traffic impacts but they may not be effective and could adversely impact project costs.</li> <li>-Careful analysis is needed to effectively apply incentive/disincentive methods to accelerate bridge projects.</li> </ul>
4. Design Quality	<ul style="list-style-type: none"> <li>-Design quality could be just as good as that of conventional</li> <li>-Limited design criteria for some elements</li> <li>-Construction loads may control design and need check</li> <li>-Require to show full connection details</li> </ul>	<ul style="list-style-type: none"> <li>-Design quality is expected to be good from standard and best practice.</li> </ul>
<b>ATTRIBUTES</b> cont.	<b>Accelerated BC (ABC)</b> cont.	<b>Conventional BC (CBC)</b> cont.
5. Construction Quality	<ul style="list-style-type: none"> <li>-Individual prefabricated elements are of higher quality under shop-controlled environment.</li> <li>-Construction quality could suffer in the field assembly due to time pressure.</li> </ul>	<ul style="list-style-type: none"> <li>-Construction quality depends on the contractor and inspection staff.</li> </ul>
6. Disciplines required	<ul style="list-style-type: none"> <li>-May require more upfront coordination between technical and non-technical disciplines and public relations.</li> </ul>	<ul style="list-style-type: none"> <li>-Standard project design and construction teams</li> </ul>
7. Experience needed	<ul style="list-style-type: none"> <li>-ABC experience is desirable especially regarding knowledge of ABC construction methods, new technologies and implementation of new design and details.</li> <li>-Additional research effort and resources may be required.</li> <li>-May require specialty construction experience.</li> </ul>	<ul style="list-style-type: none"> <li>-Standard project design experience.</li> <li>- Standard bridge construction experience.</li> </ul>
8. Public Communications	<ul style="list-style-type: none"> <li>-May require more early and upfront communication with the public for temp/short road closures</li> <li>-May need to develop a communication plan with stakeholders</li> </ul>	<ul style="list-style-type: none"> <li>- Typical</li> </ul>
9. Demolition of existing structure	<ul style="list-style-type: none"> <li>-Require full demolition plan</li> <li>-May need to provide staging place near site for off-line demolition</li> <li>-Coordination for change-over structures</li> <li>-May not require temporary structure to be in place for long duration</li> </ul>	<ul style="list-style-type: none"> <li>-Typical construction with either road closure or requires staging</li> <li>-Require full design of temporary structures for longer duration in place</li> </ul>
10. Quality Control	<ul style="list-style-type: none"> <li>-ABC elements should be verifiable during construction</li> <li>-May require constructability review</li> </ul>	<ul style="list-style-type: none"> <li>-Typical</li> </ul>
11. Owner Staff	<ul style="list-style-type: none"> <li>-Some additional effort may be expected of the owner staff in design or review of non-conventional details/procedures. Also may require more staff in a much more condensed timeframe.</li> </ul>	<ul style="list-style-type: none"> <li>-Standard</li> </ul>

### 2.2.5 Analytic Hierarchy Process (AHP) Tool

ODOT has a tool for assisting project decision makers named “ABC AHP Decision Making Program”. This program allows the project team to analyze various applicable and weighted criteria in a paired-wise comparison. With input provided either by the designer or the project team, it captures the decision based on the controlling criteria and computed utility value for each criteria.

We encourage all project designers and/or leaders to take advantage of this useful tool as part of their decision making process to determine whether ABC is preferred over conventional construction. This program may be used with input provided by the bridge engineer alone if he or she has all the available information and feels comfortable to determine the relative importance between any two given criteria. When a project is complex and involves issues or concerns by other disciplines, it would be appropriate for the project team to provide input and thus build consensus in their decision making process. Input can be collected with a survey form or entered directly into the program data fields either during or after the project kick-off meeting or when more information become available for them to better gauge the relative importance between any given paired criteria or sub-criteria.

#### 2.2.5.1 Instructions for using the “ABC AHP Decision Making Program”:

The AHP Program (in short) must be first loaded onto a personal desktop or laptop computer and must include the “dotNetFx40\_Full\_x86\_x64.exe”. It is recommended the AHP Program be copied into a separate folder. It is assumed one is familiar through reading the manual (included in the CD folder) or attended the training. In summary, here are the logical steps to get started in running the program:

1. Individual or team to establish the applicable criteria and sub-criteria for ABC decision. Refer to *Figure 2.2.5.2* and mark the ones that apply to the specific project in question. Reminder: Always save your work.
2. Optional step: Use the survey form to assign the relative value for each paired-wise criteria comparison OR skip to next step.
3. Run the Program by clicking on “AHPTool.exe” file. This will open the program under Tab 1 (Decision Hierarchy) and de-select the non-applicable criteria and sub-criteria determined in Step 1. User can add a new criterion or remove one from the default by using the “add child” or “remove” button on the right.
4. Then click on Tab 2 (Pairwise Comparison) and enter the relative values from Step 2. Reminder: Always save your entries.
5. Click on Tab 3 (Results)
6. To use Tab 4, please read and follow instructions in the Manual.

#### 2.2.5.2 Established Criteria and Sub-criteria for ABC decision

See *Figure 2.2.5.2*. Generally speaking, most transportation project decision making require some criteria that are important and specific to each site. Five main level criteria have been established and they seem to be the standard criteria used by several states for decision with ABC projects. Within each main level criterion is further defined by a sub-criterion that further expands to differentiate its elements. The definitions for each criterion are provided in Table 1 below.



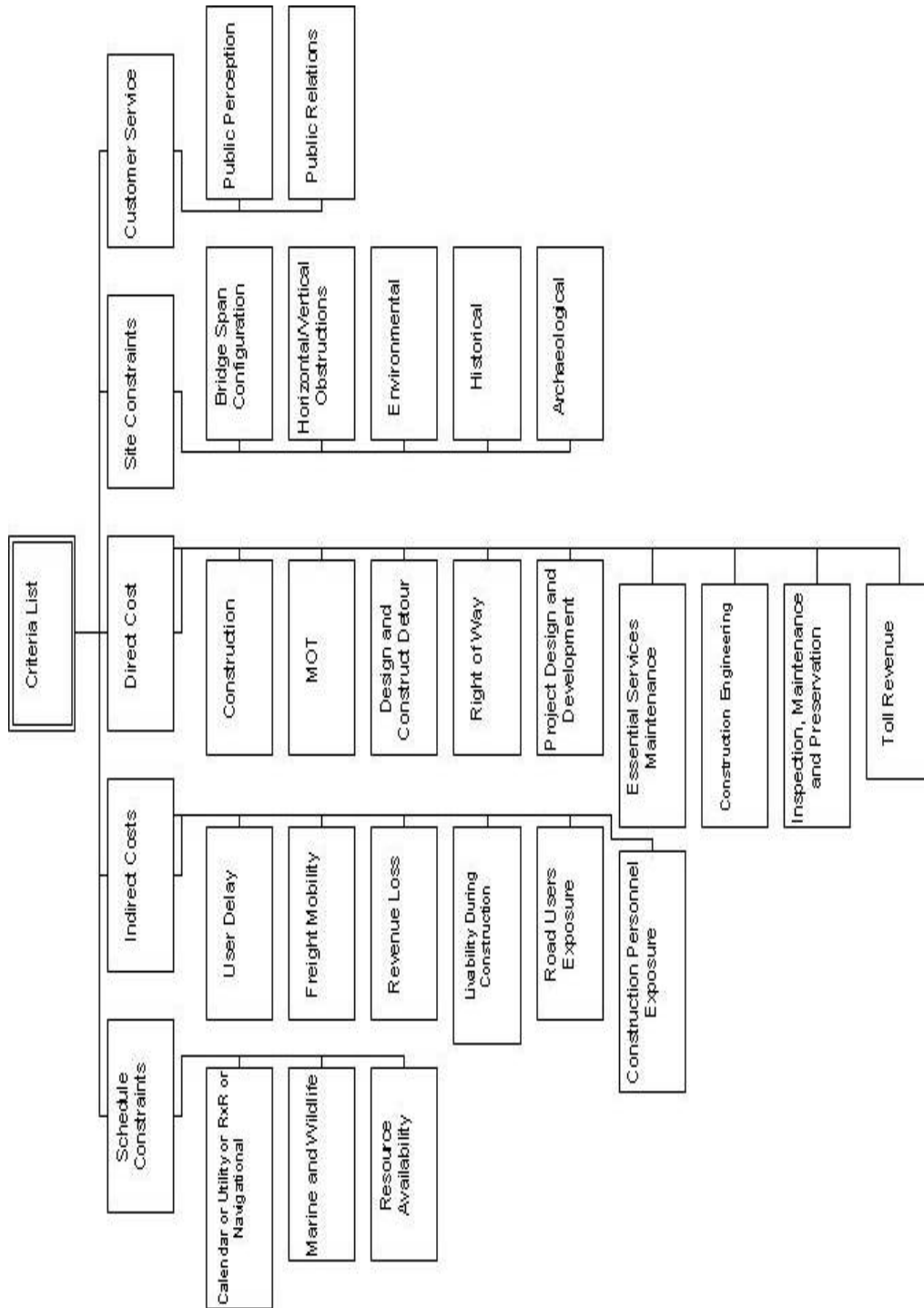

Fig. 2.2.5.2 – Main and Sub-Criteria for ABC Decision

Table 1 – Definition list of Main criteria and sub-criteria

Main criteria	Sub-criteria	Definition
Direct Costs	Construction	This factor captures the estimated costs associated with the construction of the permanent structure(s) and roadway. This factor includes premiums associated with new technologies or innovative construction methods. Premiums might result from factors such as contractor availability, materials availability, and contractor risk. It may include incentive/bonus payments for early completion and other innovative contracting methods.
	Maintenance of Traffic (MOT)	This factor captures the maintenance of traffic costs at the project site. MOT costs may impact preference due to its impact on total costs. This factor includes all costs associated with the maintenance of detours before, during, and after construction. Examples of this factor include; Installation of traffic control devices, maintenance of detour during construction including flagging, shifting of traffic control devices during staged construction, restoration associated with the temporary detours upon completion of construction.
	Design and Construct Detours	This factor captures the costs to design and construct temporary structures and roadways to accommodate traffic through the project site.
	Right of Way (ROW)	This factor captures the cost to procure ROW. This factor includes either permanent or temporary procurements/easements.
	Project Design and Development	This factor captures the costs associated with the design of permanent bridge(s) and costs related to project development based on the construction method.
	Maintenance of Essential Services	This factor captures the costs associated with the need to provide essential services that may be impacted by the construction selected. Examples of this factor include alternate routes or modes of transportation to provide defense, evacuation, emergency access to hospitals, schools, fire station, and law enforcement, etc. This criterion is for situations where measures needed to be implemented beyond those already considered in the “MOT” and “Design and Construct Detours” criteria.
	Construction Engineering	This factor captures the costs associated with the owner’s contract administration of the project.
	Inspection, Maintenance and Preservation	This factor captures the life cycle costs associated with the inspection, maintenance and preservation of individual bridge elements.
	Toll Revenue	This factor captures the loss of revenue due to the closure of a toll facility.

<b>Main criteria cont.</b>	<b>Sub-criteria cont.</b>	<b>Definition cont.</b>
Indirect Costs	User Delay	This factor captures costs of user delay at a project site due to reduced speeds and/or off-site detour routes.
	Freight Mobility	This factor captures costs of freight delay at a project site due to reduced speeds and/or off-site detour routes.
	Revenue Loss	This factor captures lost revenues due to limited access to local business resulting from limited or more difficult access stemming from the construction activity.
	Livability During Construction	This factor captures the impact to the communities resulting from construction activities. Examples include noise, air quality, and limited access.
	Road Users Exposure	This factor captures the safety risks associated with user exposure to the construction zone.
	Construction Personnel Exposure	This factor captures the safety risks associated with worker exposure to construction zone.
Schedule Constraints	Calendar or Utility or RxR or Navigational	This factor captures the constraints placed on the project that might affect the timing of construction as a result of weather windows, significant or special events, railroad, or navigational channels.
	Marine and Wildlife	This factor captures the constraints placed on the project by resource agencies to comply with marine or wildlife regulations. Examples include in-water work windows, migratory windows, and nesting requirements.
	Resource Availability	This factor captures resource constraints associated with the availability of staff to design and oversee construction. For example, a state may be required to outsource a project, which may result in additional time requirements.
Site Constraints	Bridge Span Configurations	This factor captures constraints related to bridge span configurations. This element may impact owner preference regarding bridge layout, structure type, or aesthetics.
	Horizontal/Vertical Obstructions	This factor captures physical constraints that may impact construction alternatives. Examples include bridges next to fixed objects such as tunnels, ROW limitations, sharp curves or steep grades, or other urban area structures that constrain methods and/or bridge locations.
	Environmental	This factor captures the constraints placed on the project by resource agencies to minimize construction impacts on natural resources including marine, wildlife, and flora.
	Historical	This factor captures historical constraints existing on a project site.
	Archaeological Constraints	This factor captures archaeological constraints existing on a project site.

<b>Main criteria cont.</b>	<b>Sub-criteria cont.</b>	<b>Definition cont.</b>
Customer Service	Public Perception	This factor captures both the public’s opinion regarding the construction progress and their overall level of satisfaction.
	Public Relations	This factor captures the costs associated with the communication and management of public relations before and during construction.

### 2.2.6 Steel Structures

Steel structures are excellent examples of prefabricated bridge elements and systems. They are proven to be cost effective for ABC applications. Steel girders are prefabricated and prime-coated as needed in the shop and shipped to the job site. A short closure of the affected highway facility may be required to erect them. Complete arches and trusses have been erected successfully on barges and floated into place.

Bridges built with plate girders (straight or curved) can accommodate precast concrete panels or steel grid deck systems for rapid construction. Sample connection details can be found at:

[www.fhwa.dot.gov/bridge/prefab/](http://www.fhwa.dot.gov/bridge/prefab/)

### 2.2.7 Concrete Structures

#### **2.2.7.1 Prestressed and Precast Concrete (PPC) versus Cast-In-Place (CIP)**

PPC bridge elements are typically mass produced in a PCI-certified plant under factory-controlled conditions. This results in a high quality product. PCC products can be transported to the jobsite for just in time delivery, thus avoiding re-handling or the need for storage space that might be difficult to provide in urban areas. Traffic impact at the project site can be minimized and erection can normally be done during off peak hours.

In Oregon, construction cost for PPC girders is lower than CIP girders. Unless there is a compelling reason like curvature, aesthetics, and longer span requirements, PPC girders are preferred. There is economy of scale for larger projects requiring repetition of similar spans. For elements other than girders, there is opportunity to develop effective standard elements for connecting them into bridge systems. In the erection of PPC elements, proven connection details are critical for long term performance. The FHWA has developed a manual on proven connection details. See:

[www.fhwa.dot.gov/bridge/prefab/](http://www.fhwa.dot.gov/bridge/prefab/)

### 2.2.8 Full Depth Deck Panels, Approach Slabs or Approaches and Wingwalls

Full depth deck panels are used by many states. Connection details for both steel and concrete girders exist. A survey of details used by various states was published in 2006 as NCHRP 12-65. ODOT has constructed multiple projects using full-depth precast concrete deck panels, but has not yet settled on a standard detail. ODOT does not allow partial-depth precast deck panels.

ODOT has existing standards for approach slabs/approaches and wingwalls that can be readily converted into ABC.

#### Precast Approach Slabs

- Consider issues regarding subgrade compaction and the contractors' ability to construct the surface of the subgrade to a smooth level condition prior to placement.
- Consider the ability of precast slabs to accommodate differential settlement (especially if subgrade is not level)
- Consider the design of the connection detail to pile cap/abutment wall and any joint construction.

### 2.2.9 Precast Connections in Seismic Regions

When assembling prefabricated bridge elements on site, a detailed assembly plan may be needed. For single span bridges assembly is typically not complicated. For multi-span bridges, designing and detailing of connections has to be treated with the same importance as designing the rest of the structure.

Submit new connection proposals for approval to ODOT Bridge HQ. This requirement is intended to ensure information about good connection details are subsequently distributed to other design groups. Research into new connection details has been ongoing with special concern for finding details that perform well under seismic loading. The NCHRP 12-74 research project “Development of Precast Bent Cap Systems for Seismic Regions” identified a number of bent cap-to-column details that hold promise for seismic applications. Their conclusions were released in 2011 as NCHRP Report 681. ODOT is willing to implement a few of these details only for bridges in low-to-moderate seismic regions (Seismic Zones 1, 2 or 3):

- a) Grouted Duct – Grouted duct connections consist of bent caps which have corrugated ducts to accept reinforcement extending from supporting substructure elements.

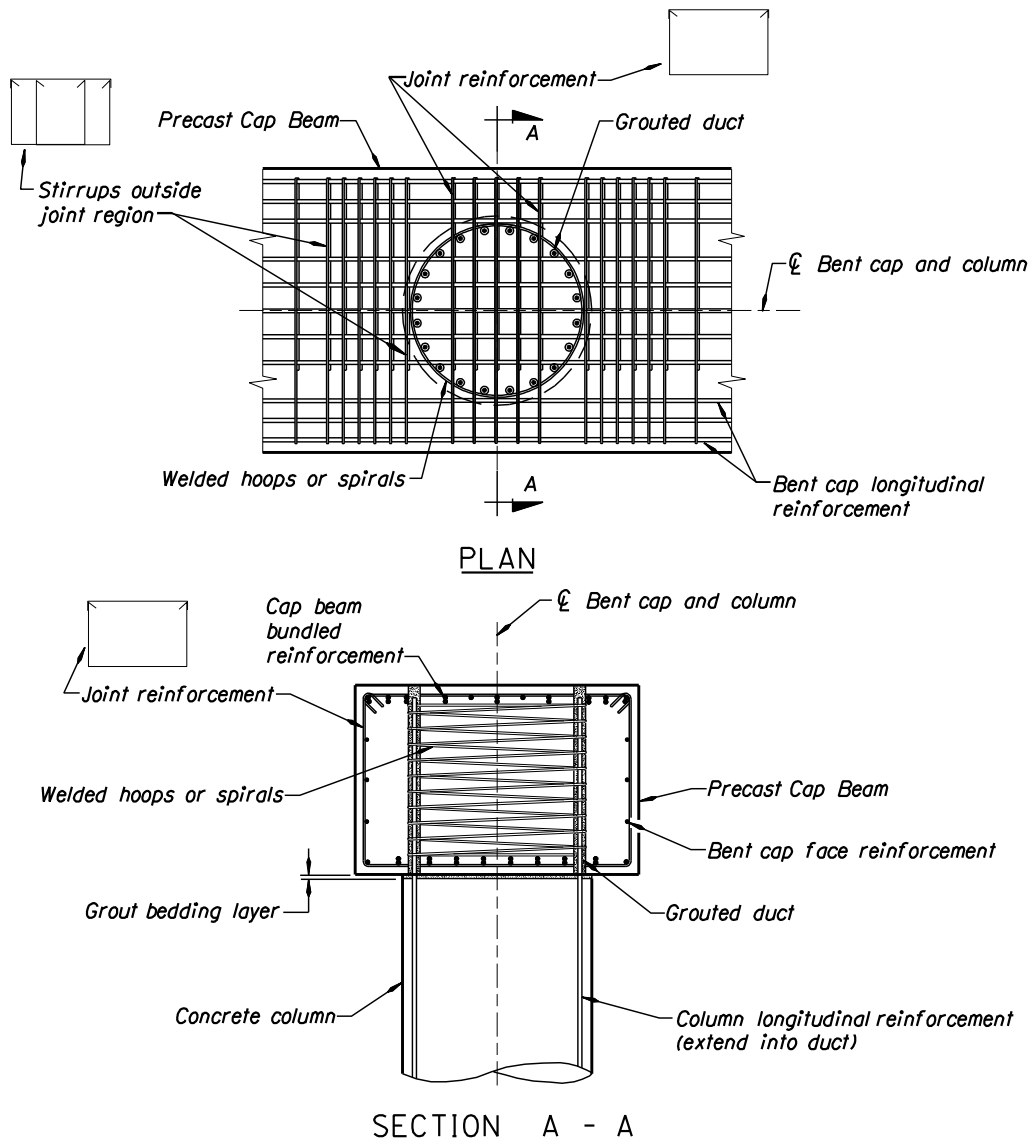

GRADED DUCT CONNECTION TO ACHIEVE FULL DUCTILITY

Figure 2.2.9A

- b) Grouted Sleeve Coupler (Coupler in Cap) – Proprietary grouted sleeve couplers are used to connect reinforcing bars in precast concrete components. These couplers are placed in the bottom-half of the precast bent cap and are designed to withstand forces at overstrength as is often required in plastic regions.

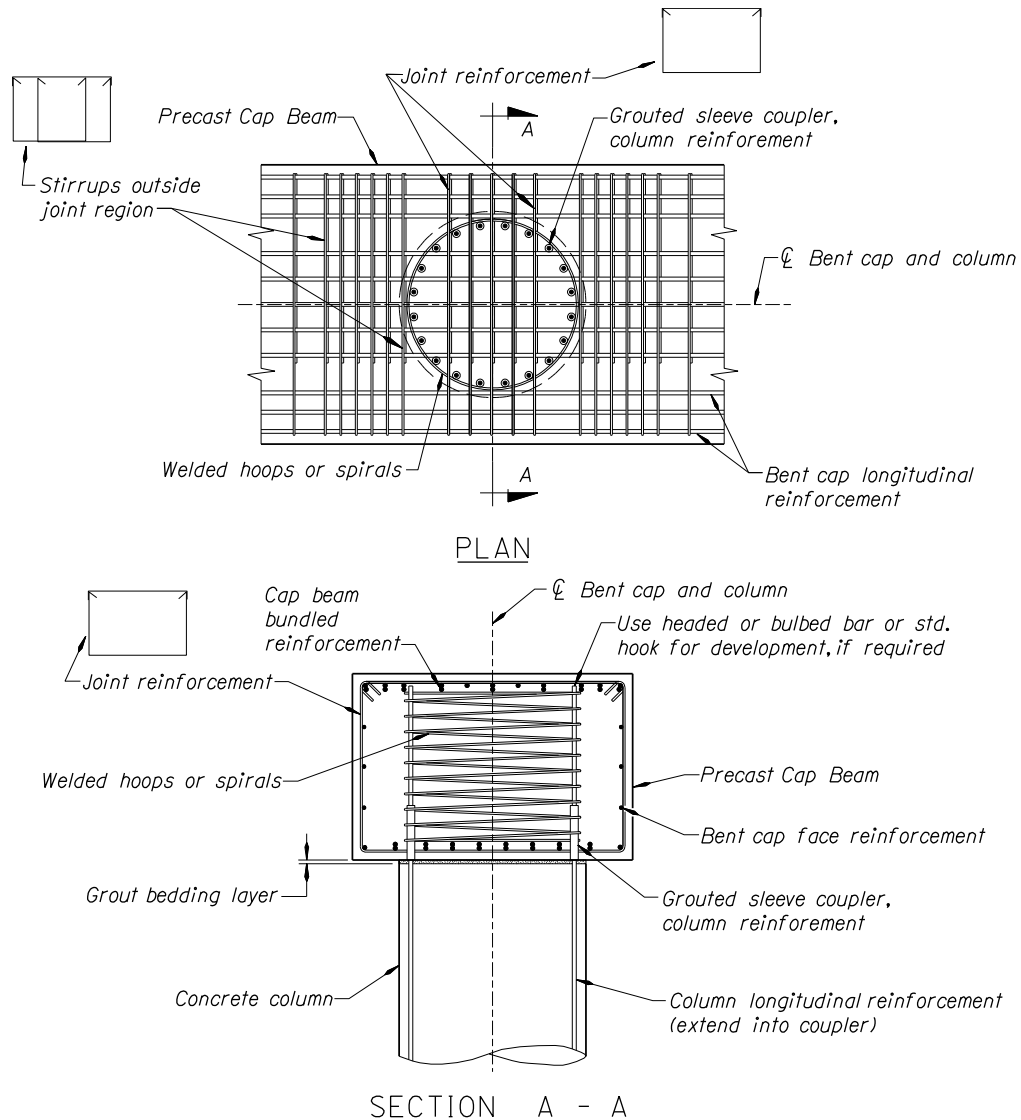

GRouted SLEEVE COUPLER CONNECTION  
TO ACHIEVE FULL DUCTILITY

Figure 2.2.9B

### 2.2.10 Use of Self-Propelled Modular Transporters (SPMT)

SPMTs can support and move heavy loads using a flat-bed mounted on multi-axle, independent suspension and steering wheel lines. They have the ability to maneuver in difficult and uneven terrain with unmatched precision and distortion control of the payload.

SPMTs can move complete superstructure spans from a staging area (e.g. gore area or off the shoulders) to the final bridge location. A bridge move can be performed on weekends or at night using the SPMTs to erect a structure into final position within a matter of hours. FHWA has a user guide manual as a resource for anyone contemplating an ABC project using SPMTs. The guide is available free of charge at:

<http://www.fhwa.dot.gov/bridge/pubs/07022/>

### 2.2.11 Geotechnical Considerations

Geotechnical designers need to consult closely with the bridge designer and the project team regarding the use of ABC methods at a particular bridge site. Continue to coordinate these efforts as necessary during the bridge design process.

Driven piling is normally the most rapidly constructed foundation type. However, piles are not suitable at every location. The most suitable foundation type for a bridge replacement or widening project depends on several factors including the subsurface materials and conditions, construction or environmental constraints and cost. Refer to the ODOT GDM; Chapter 8 for additional guidance regarding the selection of foundation types. Once the most suitable foundation type is selected for a site, thought should be given to how the foundation construction can be expedited. This should include how to minimize traffic impacts due to foundation construction. At some locations the foundations (and substructure elements) may be constructed under, or away from, the existing bridge thereby avoiding, or minimizing, any traffic impacts. If this scenario is possible, the time required for foundation construction may be less significant because it does not directly affect traffic. At sites where foundation construction will directly impact traffic and multiple foundation types are possible, consideration should be given to the foundation system that can be constructed in the least amount of time and with the least impact to traffic. Some general guidance regarding the use of various foundation systems in ABC applications are described below.

#### **2.2.11.1 Spread Footings**

Conventional Spread Footings

- Requires excavation to suitable foundation materials which may result in the need for large excavation areas and/or temporary shoring and possibly dewatering.
- Requires setting rebar, a concrete pour and curing time (and form work, if needed).

### Precast Reinforced Concrete Spread Footings

This type of ABC foundation system is currently under development. Design and construction standards and specifications do not currently exist. This type of foundation may be considered at sites where conventional spread footings would be appropriate. Precast spread footings (PSF) are currently recommended only for shorter, single span bridges at this time. Issues to consider in the application of precast spread footings would include:

- Need for construction of a concrete footing leveling slab beneath the precast footing (excavation/shoring, sloping bearing strata, presence of groundwater, etc.),
- Design of the connection between PSF and leveling slab,
- Design of the connection between the PSF and columns or abutment walls,
- Constructability issues when placing PSF directly on compacted soils,
- LRFD resistance factors for bearing and sliding resistance based on construction method, and settlement analysis.

#### 2.2.11.2 Driven Piles

Often the quickest foundation construction method and can generally have the least impact and disruption to traffic.

- Consider using fewer, higher capacity, piles per bent to expedite construction, however:
  - Using higher capacity piles may result in significantly higher foundation costs due to the need for larger pile driving hammers, leads and cranes and possible effects on the cost of work bridges due to these higher loads.
  - Using less than 5 piles per bent may result in a reduced LRFD resistance factor due to less redundancy.
  - May be most appropriate for sites with relatively short end bearing piles.
- Requires assessment of pile top alignment tolerances for precast pile cap connection:
  - Standard specifications (*SP 00520.41(f)*) allow for a horizontal alignment tolerance of 6 inches from the plan location. If a smaller tolerance is required this reduced tolerance must be specified in the special provisions. Consult with the project geotechnical engineer regarding allowable horizontal tolerances for driven piles.
  - Should piles be installed in prebored holes to meet the specified tolerances? Keep in mind the final pile alignment is only as good as the prebore hole alignment. In soils where large cobbles and/or boulders are present, or where preboring will encounter a bedrock unit with a sloping surface, prebored holes should not be augered but instead excavated using core drilling equipment. Augers tend to wander uncontrollably in these materials and borehole alignment is very difficult to maintain.
  - Consider the time and cost of preboring.
  - Consider the risk of not preboring (possibly include preboring as an anticipated item).
- Minimize the potential for in-lead splices, particularly on pile with a wall thickness of greater than 0.50 inches such that extensive welding and welding QA/QC is not required.
- Increasing estimated lengths in variable subsurface conditions will help reduce the likelihood of an in-lead splice for pile shorter than 60 feet. For longer pile consider specifying that the pile be fabricated (spliced) on site prior to putting in the leads, taking into account the cost of using larger size leads and cranes and other concerns similar to those discussed above when using fewer high capacity pile.



- Piles can be installed in existing travel lanes, in stages under traffic control, and covered over with temporary steel cover plates to keep travel lanes open to traffic until the time for substructure construction.
- At water crossings consider a trestle pile design which eliminates the need for a cofferdam (if an above ground pile cap is permissible). Potential for drift buildup should be assessed relative to the use of a trestle pile system. A web wall may be required if drift potential is significant.

### 2.2.11.3 Drilled Shafts

- Usually takes the most time to construct. Drilled shafts are often the best method for rapid in-water foundation construction, since they may omit the need for a cofferdam (unless required for environmental considerations).
- Consider fewer, higher capacity, shafts per bent, (*note that appropriate modifications to LRFD resistance factors are required for bents with less than 2 shafts*).
- Higher potential for increased risk of time delays due to problems with shaft construction or negative NDT results.

### 2.2.11.4 Micropiles

- Usually more expensive than other foundation types.
- Suitable for certain ground conditions, particularly manmade unconsolidated rock fragment fills and low overhead clearance areas.
- May be installed to tight tolerances and drilled through pavement sections.
- Consider environmental concerns relative to spoils recovery since water is typically used to flush out cuttings.

## 2.2.12 Accelerated Embankment Construction

The time required for embankment construction, (either an all new roadway embankment or a widening section) depends primarily on the volume of material required, the type of embankment materials used, the level of contractor effort and the subsurface conditions at the site. Other factors such as access, retaining wall construction and weather can also play a role and affect the speed at which an embankment can be constructed. Embankment construction may be accelerated in a number of ways. In areas where very soft ground conditions exist there is potential for significant settlement and stability issues. Consideration should be given to extending the bridge structure over these areas. This may result in a better overall design with less environmental impacts and a shorter construction period.

For ABC projects, the geotechnical engineer is responsible for evaluating the site conditions and project requirements to determine the most effective way of expediting embankment construction with the least impact to traffic flow and mobility. Refer to ODOT GDM; Chapter 9 for more design guidance on the analysis and design of embankments. ABC projects often replace bridges in the same location (same horizontal alignment) as the existing bridge with the new bridge being wider. Therefore approach embankments also need to be widened. The grade may also be raised resulting in a further increase in embankment widening. Depending on the site constraints (available access/ROW, adjacent structures, wetlands, etc) this widening can often be accomplished with minimal traffic impacts. The geotechnical engineer plays a key role in the design of these widened sections to help determine the best approach for expediting construction while taking all appropriate geotechnical design requirements into account.

The need for retaining walls on a project should be carefully reviewed. Typically an embankment can be constructed quicker than a retaining wall. Retaining wall needs are typically driven by roadway “typical section” needs that may not have been optimized to reduce the need for retaining walls. For example, the slope immediately behind a guardrail could be steepened from the typical 1V:3H or 1V:4H to steeper slopes if longer (8') guardrail posts are used rather than the typical 6 foot post lengths. Often typical fill slope rates of 1V:2H are considered in typical sections. Steeper slopes, when permitted, may omit or reduce the need for a wall. Use of stone embankment material may allow fill slopes to be constructed as steep as 1V:1.5H. If so, 8 foot metal guardrail posts may be needed to assist in penetrating the stone embankment material.

Retaining walls may be proposed in some areas to avoid, or minimize, environmental impacts. The need for walls in these areas should be closely evaluated, in consultation with the appropriate environmental specialists, to determine the underlying reasons for requiring a wall and whether or not it is the best solution for the specific location.

Some suggested considerations for embankment construction on ABC projects are summarized below:

- Use “All-Weather Materials” (stone embankment) instead of common “borrow” materials where available and appropriate. This allows construction to rapidly proceed regardless of wet weather conditions and can greatly reduce the total embankment construction time.
- Soft Ground Conditions (settlement and stability issues)
  - Lightweight fill material such as geofam
  - Geogrid reinforced embankments
  - Ground improvement techniques
  - Surcharge, with or without vertical wick drains

### 2.2.13 QA/QC, Quality Control for Prefabricated Concrete Elements

#### **2.2.13.1 Types**

ODOT has used a variety of prefabricated concrete elements on many projects. Prestressed concrete elements have been used since the 1960s. Use of non-prestressed prefabricated concrete elements dates back even earlier. The types of prefabricated concrete elements used on ODOT projects have included:

- Prestressed slabs and box beams
- Prestressed girders
- Prestressed columns
- Prestressed arch ribs
- Prestressed piles
- Bridge railing
- Bridge approach slabs
- Pile caps/abutments
- Stay-in-place deck forms
- Culverts
- Manholes and utility vaults

#### **2.2.13.2 Prestressed Elements**

When precast concrete elements include prestressing, *SP 00550* of the standard specifications apply. *SP 00550.05* requires fabricators to be certified under the PCI Plant Certification Program. PCI certification ensures that industry best practices are followed. The member tolerances specified in *SP 00550.04* are those recommended by PCI.

For non-standard prestressed concrete elements, the existing *SP 00550* Oregon Standard Specifications for Construction will likely be adequate without modification. The designer may need to create a unique bid item since the available bid items only cover our current standards.

Verify new or modified details with local precasters (Knife River and/or R.B. Johnson Co.) before design plans are final. Also confirm with the ODOT Structural Materials Engineer whether standard inspection procedures are adequate.

### 2.2.13.3 Non-Prestressed Elements

Specify concrete elements that are not prestressed under *SP 00540*. Since there is not a nationally recognized certification program for non-prestressed elements, the designer will need to determine some minimum qualifications for fabricators. Minimum qualifications may include:

- Submission of a Quality Control Plan
- Names and qualifications of key personnel
- History of similar projects
- Procedure for tracking material certifications

The nature and complexity of the project will determine which items above should be included in the minimum contractor qualifications. Solicit input from the ODOT Bridge Materials Engineer before finalizing any contract special provisions.

In addition to project qualifications, it may be desirable to require the contractor to identify the form material and forming details. Lifting and shipping details may also be required. For unique lifting and shipping situations and/or large elements, it may be necessary to require verification of lifting and shipping details. Such verification could be achieved with review by a professional engineer or by testing. Especially where there is potential for items to be fabricated by a contractor with little or no experience with precasting concrete, include special provision language to clarify any requirements that ensure safe and adequate lifting and transport details. In some cases, it may be desirable to add lifting and shipping verification as part of the contractor's Quality Control Plan.

Where precast concrete elements are specified under *SP 00540*, a special provision will be needed to address measurement and payment. Most structural concrete is paid on a cubic yard basis. However, precast concrete elements are typically paid either on a per length basis or per each.

Standard fabrication tolerances for structural concrete are provided in *SP 00540.40*. These tolerances are based on typical cast-in-place concrete construction. For precast elements tighter tolerances may be achievable and desirable. Consult with the ODOT Bridge Materials Engineer to determine reasonable tolerances for your specific application.

Inspection of precast concrete elements is required both during the precasting operation and during placement in the field. The ODOT Bridge Materials Engineer is responsible for inspection of precast elements and should be notified when precast concrete elements are to be used. This will help ensure ODOT staff is scheduled to be available for such inspections and whether any adjustment to the ODOT Nonfield-Tested Materials Acceptance Guide is needed.

### 2.2.13.4 Connection Issues

Current state-of-the art does not support connection of precast cap elements in high seismic locations. This is currently being researched at the national level.

Connection of precast elements may involve the use of grout pockets to emulate cast-in-place

construction. Where grout pockets are used, manufacturer's recommendations should be followed regarding when grout should be extended with aggregate. For many grout products, aggregate is recommended when the pocket size reaches 2 inches or more.

### 2.2.14 Cost Considerations

It has been determined by numerous projects nationally that accelerating a project delivery will reduce the costs to highway users associated with traffic queues and detours during the bridge installation. Utah DOT has demonstrated that ABC can be successful and the initial costs of innovation are absorbed on the first few projects when there is some assurance that more projects using the same technology are being planned for the near future. The use of ABC should be justified on a specific project by analyzing the user cost savings compared to the estimated cost of various methods of rapid construction (see HYRISK discussion below).

ODOT has posted a Work Zone Traffic Analysis Tool that considers such topics as traffic delays and operations, and long detours. [Guidance on Incentive/Disincentive Program](#) for designers is also available.

#### **2.2.14.1 Incentive/Disincentive Program**

Requirements related to reduced traffic impact and time must be clearly specified in the contract documents. Innovative contracting strategies to achieve accelerated construction include incentive/disincentive, a financial bonus or penalty for delivery before or after a time set in the contract; A+B bidding, cost-plus-time based on the combination of contract bid items (A) and the time bid for construction multiplied by daily user cost (B); lane rentals, assessed rental fees for lanes taken out of service during temporary lane closures for construction; and no-excuse bonus, a modified incentive with no time adjustment for problems such as delays due to weather or utility conflicts regardless of who is responsible.

Incentives and disincentives for early completion give contractors a financial reason to change their conventional practices to accelerate construction. Contractors cannot count on incentives and, therefore, may not reduce their bid price in anticipation of receiving incentives. Disincentives are necessary but may result in higher bid prices because of the risk to contractors that they will not be able to meet the reduced construction timeline. In some accelerated bridge project case studies, it was found that by providing the right incentive/disincentive, contractors were able to lower overall total project costs when compared to conventional delivery methods.

#### **2.2.14.2 Maintenance of Traffic Costs**

Traffic management and user delay-related costs associated with bridge construction activities will significantly influence the selection of the most cost-effective bridge technology.

Elaborate traffic control plans can significantly add to the cost of replacement, especially when the traffic control plan changes significantly during the project due to development, local expansion, or other projects in the area. Cost savings from the reduced duration of the traffic control plan through the use of ABC method of delivery can be estimated based on the reduced number of days of traffic control cost times the average daily operating cost of such measures for comparable bridge projects.

#### **2.2.14.3 Contractor's Operation Costs**

In general, contractors bid projects with the plan to complete onsite construction as quickly as possible to increase profits. This is particularly true for projects with incentives for early completion. The contractor's costs, including overhead costs to staff projects, are reduced when the duration of the construction project is reduced. Also, construction crew safety in the work zone is increased with reduced exposure times.

**2.2.14.4 Owner Agency’s Operation Costs**

Agency overhead costs to staff projects, e.g., construction engineering and inspection support, are reduced when the duration of construction projects is reduced. Prefabricated bridges, with their rapid onsite installation, can significantly reduce these project costs.

The use of prefabricated bridges to accelerate construction cannot be approached in a conventional manner by the owner. The owner will need to commit to working multiple shifts, odd hours, and under the same constraints as the contractor.

The manufacturers of prefabricated components may be able to offer lower unit costs if they can spread their fixed costs over many bridges and/or reuse formwork repeatedly. Bundling projects provides an attractive incentive for a contractor to acquire new or special equipment when he can recoup his investment on multiple applications.

**2.2.14.5 Available Tool: HYRISK**

How much will it cost highway users if a bridge is closed or detoured? The bridge with the longer detour requires additional time and mileage costs to negotiate the detour, and incurs the most cost to users. The cost of bridge construction alone fails to capture the total cost of the project.

A method that blends bridge construction cost and the users economic losses associated with a bridge construction is discussed below using HYRISK algorithm to compute the economic impact to a community.

AADT and detour length are extracted from the NBI record for the bridge. The assumed 2008 cost per distance traveled was equal to \$0.44/mi (\$0.27/Km). It is assumed that the project would have one year duration of the detour.

<b>Detour Mileage Cost (DMC) = Duration * Length Detour (L) * Cost/Length (CpL) *ADT</b>	
Sample Bridge Project (Br # 00138)	
Duration of facility for construction (D) in days	365
Detour length (L) in km	26
Cost per Mile per Vehicle driven of detour length (CpL)/km	\$0.27
Annual Average Daily Traffic (AADT)	330
Time cost per person (TcP)/hr	\$16.31
Occupancy rate (person) per vehicle (O)	1.56
Time cost per truck (TcT)/hr	\$29.50
ADTT (Truck Traffic as a percentage of AADT; i.e. 10% this case )	.10
Speed of Traffic on Detour (DS) in km/hr	64
Detour Mileage Cost (DMC) = D*L*CpL*ADT	\$845,600
Detour Time Cost (DTC) = D*L*[(O*TcP)*(1-ADTT)+(ADTT*TcT)]	\$1.265 M
Total Community Cost associated with bridge closure T1 <sub>cost</sub> =DTC+DMC	\$2.11 M

**2.2.15 Listing of bridges replaced using ABC techniques:**

Contact ODOT’s ABC specialist or the Bridge Design Standards Engineer to request a project be added to the list. Plans for these projects can be found using BDS (Bridge Data System).

<b>BDS Structure Number</b>	<b>Year Built</b>	<b>Region</b>	<b>Project Title</b>	<b>ABC Technique Used</b>
BR22163	2014	5	Whiskey Creek, Wallowa County	PS Slabs on steel pile caps – 2- week road closure.
BR22057	2014	2	US 26 West Humbug Creek Bridge	Used precast and prefabricated elements. Precast deck panels.
BR22105	2014	5	OR 203 Branch of Ladd Creek Culvert	Inverted rigid frames with precast prestressed slabs as top panels, 30-foot spans. Used short bypass 2-lane detour.
BR00711	2013	2	US101B Lewis & Clark River Bridge	Partial ABC with CIP deck. Used some precast and prefabricated elements.
BR21548 BR21549	2012	5	US 26 Dean and Dog Creek Culverts	Inverted rigid frames with precast top slabs to form a single cell box, 16-foot span. Used centerline shoring.
BR21252	2012	5	US30 Burnt River (UPPR)	Precast PS Deck Panels with UHPC joints and connections. Steel diaphragms. FHWA Demo Project for Life Grant.
BR21439	2012	3	Hwy 1 Kane Creek Frtg Road LT (Old Stage Road)	Precast pile caps, end panels and wingwalls.
BR21493	2011	1	Sellwood Bridge, Willamette River	Slide bridge into place using "Shoo Fly" technology. <a href="http://SellwoodBridge.org">SellwoodBridge.org</a>
BR21188	2010	2	US26 Volmer Creek Bridge	All precast or prefabricated elements (staged construction).
BR21189	2010	2	US26 Johnson Creek Bridge	All precast or prefabricated elements (staged construction).
BR20584 BR20585	2008	3	OR 38 over Elk Creek Bridges near Elkton	1 steel plate, 1 Bulb-T girder bridge built on temporary falsework adjacent to the existing. Skidded on tracks during two weekend road closures.
BR20586	2008	3	OR 38 Bridge over Hardscrabble Creek, Douglas County	Bridge built adjacent to the existing and skidded into place.
BR02398	2008	5	Kimberly Bridge OR19, Grant County	Rapid replacement of 2 approach spans using precast pile caps on a long structure with 20-day full road closure.
BR01132 F	2007	3	Hwy 241 Isthmus Slough (east side)	Constructed substructure around existing bridge.
BR19273	2007	3	Depot Street Bridge over the Rogue River, Jackson County	306-foot concrete arch built adjacent to existing bridge and skidded into place. Road closed for 5 days.
BR20136	2007		Sauvie Island Bridge over Columbia River, Multnomah County	365-foot steel tied arch. SPMT used to skid and load bridge on barges and floated span into place.
	2007	1	OR 47 over Dairy Creek Overflow Bridge, Washington County	Used steel pile cap and reused salvage precast, prestressed slabs. Road closed for 14 days.
BR20238	2006	2	US 20 Bridge over Hayes Creek, Eddyville, Lincoln County	Used precast cap and slabs. Bridge constructed during a 72-hour road closure.
BR00711	2004	WSDOT Lead	Lewis & Clark Deck Replacement	SPMT used to replace superstructure 5478' L X 34" W, 34 panels. Conventional method duration was 4 years. Using ABC, done in 6 months with full road closure.
BR01660	2002	4	OR 26 Mill Creek Bridge Deck Replacement, Wasco County	3-span continuous truss with deck panels. Panels replaced sequentially with partially concrete filled exodermic steel grid deck. 540-foot deck replaced in 24 days under flexible road closure schedule.
BR07333	1997	1	I-5 (Interstate) Bridge over Columbia River, Multnomah County	Accelerated replacement of 2 trunnion assemblies and span/counterweight cables. Contractor awarded \$1.4+M incentive (\$100K/day) for early completion in less than 7 days; 14 days ahead of the required 21-day schedule.
BR18074	1997	5	Imnaha Bridge over Little Sheep Cree	Single span, concrete-filled grid deck over steel curved girder bridge. Built first half of new bridge and switched traffic over; demolished existing bridge and built second half with skidding to connect the two halves. Longitudinal concrete closure-pour in the middle
BR02529	1973	1	Freemont Bridge over Willamette River, Multnomah County	Arch span was floated on barges and moved into place using strands jacking.
			Sam Jones Bridge	Full depth precast deck panels.

### 2.3 STRUCTURE APPEARANCE AND AESTHETICS

#### [2.3.1 General](#)

#### [2.3.2 Location and Surroundings](#)

#### [2.3.3 Horizontal and Vertical Geometry](#)

#### [2.3.4 Superstructure Type and Shape](#)

#### [2.3.5 Bent Shape and Placement](#)

#### [2.3.6 End Bent Shape and Placement](#)

#### [2.3.7 Parapet and Railing Details](#)

#### [2.3.8 Colors](#)

#### [2.3.9 Textures](#)

#### [2.3.10 Ornamentation](#)

#### **[2.3.1 General](#)**

Keep in mind the structure appearance with respect to its surroundings and the context of the site.

ODOT has no general directive or mandate on aesthetics or aesthetic design. This section is a guideline to generally accepted practice.

Generally for bridges, appearance is best when elements are few and simple.

Bridge elements are pleasing when the structural intent is clear with respect to the size and shape of the element. Elements forced into a non-structurally responsive shape for decoration are not considered aesthetically pleasing and may be a significant distraction and a safety hazard. Decorations on bridges that are not part of the structural support system may not be maintained to the same level as the structural portions of the bridge unless a separate IGA is executed with a local agency for maintenance.

Aesthetics and environmental considerations may have apparent conflicts. Historic or environmental issues may impact the bridge rail type, structure configuration, type of foundation or bent placement. Start the permit application and coordination process for historic structures as early as possible in the design stage. Aesthetics concerns, especially within an existing documented site context, are valid issues that can and should impact resource agencies permitting considerations.

There is a misconception that improving appearance always costs more. This is not necessarily true. The challenge to the engineer is to use creativity and ingenuity to improve the appearance without increasing cost. When people think that improved appearance is going to add costs, they are generally thinking in terms of add-ons, special ornamental features or special colors. The greatest aesthetic impact can be made by the structural elements themselves. These are seen first, and at the greatest distance. The bridge can be made attractive if these major elements are well shaped, and if they fit in well with the surroundings.

The following topics are commonly known to assist in producing visually pleasing structures. They are discussed in more detail in the following sub-sections.

- Location and surroundings
- Horizontal and Vertical Geometry
- Superstructure Type and Shape
- Bent Shape and Placement
- End bent Shape and Placement
- Parapet and Railing Details
- Colors
- Textures
- Ornamentation

### 2.3.2 Location and Surroundings

When determining the appearance of a bridge, the bridge must be considered in context with its surroundings. Decisions need to be made regarding what color, shape and type of bridge will look best at a given location. The surrounding area may be industrial, urban, or rural. A bridge that looks pleasing in a rural setting may look totally out of place in an urban area.

Individual bridges that span a major land area or body of water, because of their large size, dramatic location, and carrying capacity, will tend to dominate their surroundings. While these structures must harmonize with the surroundings, their importance and size requires that the aesthetic qualities of the structure stand on their own. Multiple bridges seen in succession create a cumulative aesthetic impact on the landscape that must be considered. In these situations, there is more reason for uniformity, and there should be no noticeable differences between structures, without an obvious reason. A specific theme for a particular route, such as a parkway, is often appropriate.

Routine bridges, such as highway overpasses and stream crossings, should be simple, with minimal changes, and with all of the elements in clear relationship with one another. Since many of these bridges are viewed in elevation by those traveling on a roadway below, the structure type, span lengths, and proportions, as viewed in elevation, should be carefully considered.

Bridges that are infrequently viewed, such as those on lightly traveled roadways, are rarely seen by anyone. In these cases, attention to the elements that can be seen from the roadway surface such as parapets, railings, transitions, and road surface, are important.

### 2.3.3 Horizontal and Vertical Geometry

Geometric design standards often dictate the orientation of a bridge. The emphasis is on the need for safe, convenient driving and providing a more attractive highway system. Bridges must adapt to the highway alignment. Thus, they often lie within the curvature of the road and follow the slopes or curvature in elevation. Large curvature is not only desirable from a safety standpoint, but also for aesthetics.

With skewed structures, when it is necessary to orient the substructure parallel to the feature crossed, a wide bridge presents a greater visual impact. The use of natural surfaces that blend in with the surrounding environment may lessen the visual impact. Bents and end bents in waterways that lie parallel to the river's banks look better than those placed perpendicular to the crossing road.

If an alignment requires a curved bridge, then the external longitudinal lines, traffic barriers, and fascia lines of the structure should follow the curved centerline to provide a smooth visual flow. A smooth transition helps the structure fit in with the local topography. Parallel lines should be maintained by matching barrier, sidewalk, curb and fascia depth across the structure.



### 2.3.4 Superstructure Type and Shape

The appearance of a bridge is greatly influenced by different aspects of the superstructure. These include the superstructure type, depth, overhang width, number of spans, and span lengths. One way to make the structure light and slender, without making it appear weak and unsafe, is to use a favorable visible slenderness ratio (the ratio of span length to the visible structure depth, including the decking and any concrete traffic barrier or steel railing). The typical visible slenderness ratio will vary from approximately 10 to 40 depending on the type of superstructure chosen.

A girder depth that is too shallow gives the appearance that the bridge is not structurally safe. A girder that is too deep makes the bridge look bulky and overpowering. Bridges with a well-proportioned slenderness ratio denote strength without excessive materials.

An additional guideline that enhances the appearance of multiple spans is to avoid changing girder depths from one span to another. This would give a very awkward appearance and would not allow the structure to flow evenly across the bridge. From an aesthetic standpoint, deck overhang should be proportional to the girder depth; a desirable overhang would be about  $\frac{2}{3}$  the girder depth. Vertical stiffeners make steel girders seem heavier, and should be avoided on the fascia side of fascia girders. Haunched girders can make a bridge look more slender, and help demonstrate the flow of forces in the bridge. Fishbelly girders create a heavy look, and could tend to look awkward. Some structure types are more visually elegant than others, such as trapezoidal box girders and concrete segmental bridges. An arch bridge is one of the most natural bridge types, and generally considered one of the most pleasing. Both thru and deck arches can be considered.

### 2.3.5 Bent Shape and Placement

The visual impression that a person gets from a bent is primarily influenced by the proportions, the relative width and height, and the configuration of the bent cap with respect to the bent columns. Bent proportion, in turn, is determined by the bridge geometry and superstructure type and shape. Bents can broadly be classified as either short or tall. Short bents are typically more difficult to design with aesthetic proportions. Care should be taken in proportioning a bent to make sure that horizontal lines of the superstructure are not interrupted. Large bents may direct attention away from the superstructure. Bents that are too slender may convey a feeling of instability.

However, there are aesthetic issues that are common to all bent types involving the shape of the columns and the bent caps. The selection of the proper bent type can be dictated by the site, bridge geometry and design considerations.

The shape and location of the columns affect the appearance of the bents. The light reflecting from the surface often controls how the viewer perceives it. A square or rectangular column with beveled corners will appear more slender due to the edge lines and varying shades of reflected light. The designer needs to assure that the treatments used are in harmony with the rest of the structure. Bent caps, cantilevered ends, and column spacing can be designed to make the bent appear more graceful. For hammerhead bents, the stem width and height, and the cantilever length and depth should be carefully balanced, and in pleasing proportion. Solid bents can be battered to improve their appearance. The batter should be determined by the bent height and the relative dimensions at the top and bottom of the bent. Gradual lines are important. While tall bents are less common than short bents, they allow a greater opportunity for aesthetic treatment.

### 2.3.6 End Bent Shape and Placement

For most simple span bridges and some multi-span bridges, the end bents are the most visible elements. While the end bent's function is to support the superstructure and transfer loads to the ground, it is important to maintain proper proportion in order to create a good appearance. Good proportions between various elements of the bridge give character to the bridge. For the end bents it is important to consider

the relationships between the exposed end bent height and length, the size and type of wingwalls, and the superstructure depth. An attempt should be made to achieve a balance between these elements.

The designer must maintain order between the lines and edges of the structure. Too many lines, or lines that are close to but not parallel to each other, can disrupt the eye and diminish the appearance of the bridge. The monotony of a large flat wingwall can be broken up using textures such as scoring, recessing, or grooving. Surface textures, either by using or simulating natural stone around the area of the bridge, can be used to integrate the structure with its surroundings.

The orientation of the end bents to the feature crossed will create different visual appearances. End bents on severe skews can have very long stems and wingwalls. Consideration should be given to the aesthetic impact of those concrete surfaces. Wingwalls are often very predominating features. The orientation of the wingwalls allows for more or less visual impact. On divided roadways, the view presented from the opposite direction of travel should be considered.

#### **2.3.7 Parapet and Railing Details**

The railings or barriers, along with the deck fascia and fascia girders, are sometimes the most dominant visual aspect of the bridge. The railings are viewed by people traveling under the structure who see them in elevation and by people in vehicles on the bridge traveling parallel to them. When vehicle speeds are high, the railing or barrier should have simple and pronounced details because passengers cannot notice fine details. The shape of the railing or barrier system should relate to its function and the overall aesthetic design of the bridge.

The design and appearance of any fencing to be placed on the bridge should be consistent with the railing or barrier system. The vertical supports of the screening should align with the railing post spacing. Fencing on concrete barriers should be detailed to match the construction joints and the ends of the barriers.

#### **2.3.8 Colors**

When there is a reason to color the concrete, steel, or railings, a decision should be made whether the color should complement or contrast with the surrounding environment. Strong consideration should be made to the fact that colored concrete or steel will require a high level of maintenance. The designer should also consider the appearance if regular maintenance is not performed (e.g., peeling paint, rust spots, etc.).

Coloring agents are not allowed in concrete because of complicated quality control, difficulty in matching colors in each batch, and the high cost of materials. It is nearly impossible to get an identical color of concrete from one pour to the next, or over a period of time between placements. Staining concrete can create a mottled appearance when appropriate to match natural stone, and can be effective if a trial section is used to qualify the process. External coatings are allowed, and when applied correctly can achieve the desired appearance. However, they have durability limitations, and must be used with caution due to concern regarding the owner's ability to maintain the coating.

#### **2.3.9 Textures**

Texturing concrete can be achieved through form liners, panels, stone or brick veneer, or acid washing. Any texturing should fit in within the overall design and proportions of the structure.

Several types of commercial form liners are available. Natural stone or brick facades can also be used. Stone is most often used for parkway bridges and those in rural settings. The cost of stone covering can be quite high; and should therefore be limited to areas of high visibility and established contextual settings. When a concrete cap is used on the top of a wingwall or retaining wall, it should be visually proportioned to the wall itself.

### 2.3.10 Ornamentation

Ornamentation can be added to a bridge in special circumstances. The additional cost of add-ons is rarely justified except in cases of importance to the community (such as a gateway to a city) or of historical significance. Details such as ornamental light posts, columns or pylons, real or simulated gatehouses, commemorative plaques or reliefs may be added. The designer should consider these details carefully since it is just as easy to detract from the overall appearance of the bridge, as it is to improve it.

Such details are secondary to the primary purpose of the structure, which is to provide a safe and efficient crossing to the public. Ornamental and non-structural details require additional coordination, sketches and drawings to ensure that the details will add to the aesthetic characteristics of the structure in a way acceptable to all concerned.

Local stakeholders sometimes request ornamental screening and features on overpass structures to showcase local attractions as a gateway to their community. Ornamental protective screening should not be a distraction to drivers, and must not cause sight distance or clearance problems. Treatments must not reflect a commercial interest. *See BDM 1.13.4* for additional screening requirements.

### 2.4 BRIDGE TYPES & SELECTION GUIDANCE

#### [2.4.1 Bridge Types and Economics](#)

#### [2.4.2 Substructure Guidance](#)

#### [2.4.3 Special Considerations for Federal-Aid Projects](#)

#### [2.4.4 Use of Salvage Materials](#)

### [2.4.1 Bridge Types and Economics](#)

#### (1) [General](#)

Bridge superstructure type is generally the most important factor influencing bridge costs. Substructure cost is normally included in bridge deck area unit cost. In some situations, the substructure cost can be greater than 50% of the unit cost, when significant seismic design and details are required for the bridge. Each project site is unique and should be evaluated for conditions that alter the usual cost expectations. For usual cost expectation of bridge deck area unit cost, refer to [Bridge Section's annual Bridge Cost Data](#) for bridges constructed in Oregon and the [FHWA website](#) (<https://www.fhwa.dot.gov/bridge/nbi/sd.cfm>) for structures in other states in the national bridge inventory. Use the last 3-years average unit cost as a basis for comparison.

If an estimated deck area unit cost for a bridge with a typical substructure is more than 15% higher than the average unit cost shown in both the Bridge Section's Cost Data and the FHWA bridge replacement unit cost, inform the design lead and design team as soon as possible including the reasons for the higher unit cost. Re-evaluate the alternatives with the design team for their effectiveness at meeting the project's basic goals and look for innovative solutions to address the high cost.

Various types of bridge superstructure provide efficient solutions for different span arrangements. There are many reasons for choosing particular span length(s) for a bridge, some of which are discussed below. There is generally significant overlap for common span ranges, so multiple bridge types are viable. The following table shows various bridge types categorized by construction material and method of construction with the design span ranges.

Bridge Type	Span Range
Precast concrete slabs	up to 83 feet
Precast concrete box beams	up to 120 feet
Cast-in-place concrete slabs	up to 66 feet
Precast integral deck concrete girder	up to 130 feet
Precast concrete girder, BT72	up to 140 feet
Precast concrete girder, BT84	up to 160 feet
Precast concrete girder, BT90 & BT96	up to 183 feet *
Cast-in-place box girder	up to 160 feet**
Cast-in-place post-tensioned box girder	up to 300 feet**
Steel girder	40 to 400 feet
Steel box	200 to 400 feet**
Steel truss	greater than 300 feet

\* Length for BT90 & 96 is limited by prestressing bed capacity for Oregon precasters.

\*\* Normally used for longer, multi-span continuous bridges.

When using precast or prefabricated girders, verify that there is an acceptable route for shipping. As girder lengths increase, shipping becomes more difficult on roadways with sharp curves, high superelevation and/or load-restricted bridges.

Timber bridges up to 30 feet of length may be considered for special situations (See *BDM 1.8.1*). The cost of a timber bridge may be more than concrete and steel bridges of the same length.

Do not use cast-in-place concrete slabs with any span greater than 66 feet. Cast-in-place concrete slab superstructures have significant dead load deflections. Even if actual deflections match estimated deflections, it will likely take 10 to 15 years for creep deflection to diminish. For longer span lengths, the ride quality would be unacceptable while waiting for the creep deflection to occur.

Do not use voids in cast-in-place concrete slab superstructures. Although such designs are effective at reducing the structure weight and dead load deflections, it is very difficult to secure the voids in the field. The potential for failure is unacceptably high.

When cast-in-place slabs are used, ensure the edge beam requirements in *LRFD 4.6.2.1.4, 5.14.4.1 and 9.7.1.4* are met.

Where a design deviation is approved by the State Bridge Engineer for use of voids in a cast-in-place concrete slab superstructure, apply the edge beam requirements listed above to this type of bridge.

Use HPC concrete in cast-in-place concrete slab superstructures. Place concrete full-depth of the slab (i.e., no horizontal construction joints). For cast-in-place slab superstructures having any span greater than 40 feet, apply a deck sealer product (from the QPL) at least 60 days after placement of the slab.

### (2) Precast Concrete versus Cast-in-Place Concrete

Formwork is the key to concrete structure costs. Use of standard forms or repeated use of specially built forms means lower costs. For smaller bridges in remote areas, precast or shop-fabricated elements usually lead to the most economical solution. Also see *BDM 2.2, Accelerated Bridge Construction*, for more guidance in the use of precast elements.

Precast concrete slabs have the following advantages:

- Good for shorter stream crossings, low-volume roads, and remote locations
- No falsework required in roadway or stream
- Fast, simple installation, saving construction time
- Shallow depth providing greater clearance to stream or roadway surfaces below

However, they have problems with:

- Providing smooth riding surfaces. (Wearing surface is required to level up except for low-volume roads.)
- Accommodating horizontal curves, gradelines, or superelevations. (Thickness of AC-wearing surface to accommodate superelevation can become excessive.)

Precast concrete box girders, and deck Bulb-T girders have most of the same positive and negative points as precast concrete slabs. They can accommodate longer spans, but they do have deeper depths resulting in less clearance to stream or roadway surfaces below.

In general, cast-in-place concrete spans are a good choice for:

- Accommodating horizontal curves, gradelines, or superelevations
- Longer spans

However, three drawbacks are:

- Falsework is required
- Falsework in the roadway below a grade crossing creates traffic hazards
- Settlement of falsework before post-tensioning begins is a potential problem

### (3) Short Span Steel Bridges

Steel provides an excellent solution for short span bridges because steel is often lighter than other materials for the same span, resulting in smaller or fewer erection cranes and smaller substructures. In addition, short span steel bridges can be fabricated off-site in a controlled equipment and be ready to erect as soon as it reaches the bridge site. Several section options are available depending on the length of the bridge, including buried plate structures, wide flange shape/rolled beams and plate girders for span length from 20 feet to 140 feet as shown in the following figure.

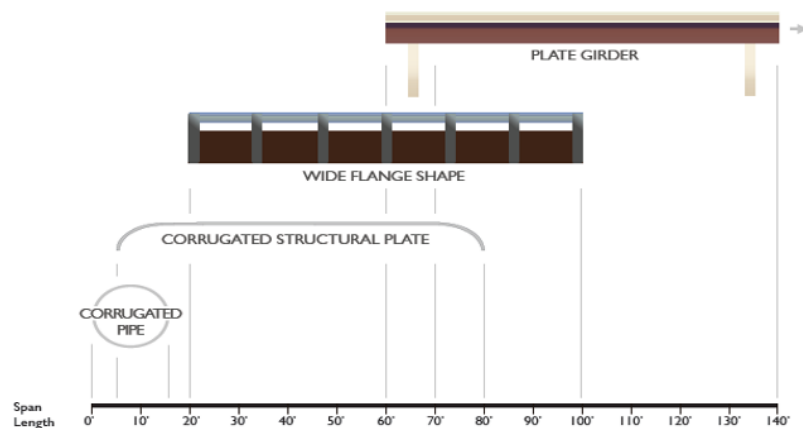

### (4) Composite Steel Girder Bridges

Steel construction extends the span length range and usually does not require falsework in the roadway or stream. Used for simple spans up to 260 feet and for continuous spans from 120 feet to 400 feet. This bridge type has relatively low dead load when compared to a concrete superstructure which makes it an asset in areas where foundation materials are poor. Shipping and erecting of large sections must be reviewed.

### (5) Bridge Widening

Generally, a type of construction that matches the existing bridge should be considered for the widened portion. It is desirable to design the widened portion to have a similar appearance to the existing. With these considerations, similar stiffness between the existing and widened structures can be achieved.

### (6) Design Criteria for Major or Unusual Bridges

Some elements of design criteria for major and unusual bridges may not be appropriate for normal bridges and may be dependent on the location and expected service level. For those bridges the design criteria will be established specifically for each bridge in a collaborative effort between ODOT Bridge Engineering Section and the Region. Early coordination is required to allow time to establish the design criteria. See [BDM 2.4.3\(2\)](#) for further guidance regarding Unusual Bridges.

### (7) Maintenance and Provisions for Inspection of Bridges

- Formal constructability and maintainability reviews by representatives of the Construction and Maintenance Sections are required for most bridges to determine the practicality and feasibility of erection/construction of the bridge as assumed in the design as well as adequacy for future maintenance.
- Preparation of an Inspection and Maintenance Guide for the future operation of each major or unusual bridge (see *BDM 3.10.8*).
- Consider designing for the possibility of future bearing replacement. Bearing replacement requires the use of jacks to lift the superstructure off the bearings to be replaced. Indicate the position of these jacks, and allowable jacking loads, on the drawings. Provide distribution reinforcement to accommodate the jack loads in the top of the piers and the soffit of the superstructure. Further, consider the relocation of the reactions in the transverse analysis of the superstructure when the jacks are engaged to replace the existing bearings.
- Bridges fabricated from coated structural steel should be designed for future recoating according to *BDM 1.6.4.4.1*.

### 2.4.2 Substructure Guidance

See *Section 1.11* for information and design guidelines for end and interior bents and wingwall layout.

### 2.4.3 Special Considerations for Federal-Aid Projects

#### (1) Alternate Designs

According to the Federal Highway Administration (FHWA), the practice of providing alternate designs for major bridges results in substantial savings in bridge construction costs. Current FHWA policy states that use of alternate designs is optional and at the discretion of State highway agencies. If alternate designs are appropriate, consider the following:

- Utilize competitive materials and structural types.

Prepare each alternate design using the same design philosophy. (That is, LRFD design, finite element analysis, etc.) Ensure the design/construction requirements for the entire bridge (foundation, substructure, deck) are compatible.

- Prepare estimates for all Alternate Designs during the TS&L design phase.

**Note:** Do not confuse this 'Alternate Designs' with the TS&L 'Alternatives Study'. This Alternate Designs is the actual preparation of two or more designs, and plan sheets, to be included in the bid documents.

#### (2) Unusual Structures

FHWA policy requires "unusual bridges" to be approved (by FHWA) before being designed. An "Unusual bridge" may have:

- Difficult, new or unique foundation elements or problems
- A new or complex design concept involving unique operational or design features
- Design procedures which depart from current acceptable practice

Examples of unusual bridges include:

- Cable-stayed, suspension, arch, segmental concrete, moveable, or truss bridges, and other bridge types which deviate from AASHTO *Design Specifications* or *Guide Specifications*
- Bridges requiring abnormal dynamic analysis for seismic design
- Bridges designed using a three-dimensional computer analysis
- Bridges with span lengths exceeding 500 feet
- Bridges with major supporting elements of ultra-high-strength concrete or steel

Other unusual structures include:

- Tunnels
- Geotechnical structures featuring new or complex wall systems or ground improvement systems
- Hydraulic structures that involve complex stream stability countermeasures
- Designs or design techniques that are atypical or unique

Where unusual bridges are identified, seek FHWA involvement at Project Initiation. Do not advance the design beyond TS&L without FHWA approval.

### (3) Experimental Features Program

An experimental feature is a material, process, method, or equipment item that:

- Has not been sufficiently tested under actual service conditions to be accepted without reservation in normal highway construction, or
- Has been accepted, but needs to be compared with acceptable alternatives for determining relative merits and cost effectiveness.

Although the Experimental Features Program is normally used in conjunction with Federal-Aid projects, the program format has occasionally been followed for projects funded entirely with State funds. In some cases, FHWA has paid part of the research cost for basically a State-funded experimental program.

The intent of the Federal-Aid Experimental Features Program is to allow ODOT time to develop, test, and evaluate specifications for new, innovative, or untried products or processes.

### (4) Specifying Proprietary Items

To encourage competitive prices from manufacturers and suppliers, FHWA has established a policy for specifying proprietary products or processes for Federal-Aid projects. Generally, “proprietary” means:

- Calling out a product on plans or in specifications by brand name
- Using specifications written around a specific product in such a way as to exclude similar products

The policy basically says:

- You must use two, preferably three, products when specifying by name brand
- You can use generic specifications patterned after a specific item if at least two manufacturers can supply the item

On the other hand, specifying one proprietary item is allowed only:

- If it qualifies for the experimental features program
- If, with written justification from ODOT, FHWA specifically approves in advance a single product, which is essential because of compatibility with an existing system, or the only suitable product that exists



### (5) Use of Debris from Demolished Bridges and Overpasses

Public Law 109-59, dated August 10, 2005, Section 1805 mandates that for Federal-Aid bridge replacement and rehabilitation projects, States are “directed to first make the debris from the demolition of such bridge or overpass available for beneficial use by a Federal, State, or Local government, unless such use obstructs navigation.” Links are provided for more information:

- [Public Law 109-59](#) August 10, 2005
- [FHWA Memorandum of March 7, 2006](#)

Note that environmental regulations may prohibit the use of debris in waterways.

### 2.4.4 Use of Salvage Materials

ODOT Bridge Engineering Section does not prefer the use of used bridge items. New materials are required for new and replacement bridges, and for added portions of widened bridges. Incorporation of used materials requires an approved Design Deviation (see *BDM 1.2.2*). The following are issues to be considered and included in a deviation request.

1. Locate and include in the project records for the new bridge all original material certifications and documentation of material properties.
2. Document the condition of the used materials.
3. Locate and include a copy of applicable portions of the original calculation book in the project records for the new bridge. The copied portions may be scanned and transmitted electronically to the design engineer. Hard copies should be made and included in the calculation book for the new bridge.
4. Prepare a new calculation book for the new bridge.
5. Document agreement from FHWA (on Federal projects) with a Public Interest Finding processed through Roadway Section.
6. Designate on the new plans the portions of the new bridge that are built with salvaged materials.

### 2.5 BRIDGE LAYOUT

#### [2.5.1 Site Constraints](#)

#### [2.5.2 Spans and Proportions](#)

#### [2.5.3 Bridge Length](#)

#### [2.5.4 Substructure Guidance](#)

#### **[2.5.1 Site Constraints](#)**

At the start of the Preliminary Design Phase, after collecting and reviewing available project data, start identifying site constraints that will impact or affect the bridge layout. Suggested items to discuss with respective project team members (list may not include all applicable items):

- Right of way
- Geology; poor soils
- Known buried hazardous materials
- Waterway; thalweg, potential scour areas
- Floodplains
- Riparian zones
- Wetlands
- Historic resources
- Archeological sites
- Buildings
- Parks
- Air space envelope
- Fluvial envelope
- Railroad envelope

Consider these items early in the bridge layout process. Learning of these constraints later may cause rework that can affect both schedule and budget.

#### **[2.5.2 Spans and Proportions](#)**

##### (1) [Column Locations](#)

Column locations, which of course affect span lengths, are subject to clearance requirements of *BDM 3.14.4.2*, *AASHTO* standard clearances, and hydraulic considerations. After these conditions are met, spans lengths may also be governed by environmental issues, economics and aesthetics. Consider alternate structure types to best fit the needs of the site.

Consider the effects of columns in waterways when locating columns and setting span configurations. Consider the possibility for scour or difficulty in inspecting a column that is in the highest flow area of a river. Avoid placing the column directly in the middle of the river.

Protect columns located in the median of a divided highway and within the clear zone (as determined by the Roadway Designer), from traffic by a guardrail or concrete barrier. Check with the Roadway Designer regarding which barrier will be used. It will affect the bridge's appearance and may influence the type of column selected. Design according to *BDM 1.3.4*.

(2) Structure Depth

Structure depth including deck (also referred to as superstructure depth) is generally controlled by span length and clearance limitations. Although a minimum depth structure may be aesthetically appealing, it may not be the optimal solution for the site.

For steel superstructures, use the minimum depth recommended in *LRFD Table 2.5.2.6.3-1* for estimating purposes. Girder depths for haunched girders made continuous may be reduced up to 20 percent. For haunched girder, use minimum depth of L/40 at center of span and L/20 at intermediate bent.

For concrete superstructures with continuous spans, use the minimum depths given below:

Reinforced Concrete Superstructures:	Minimum Depth:
Balanced 3-span cast-in-place slabs with main reinforcement parallel to traffic	$d = 0.542 + L/48$
T-Beams	$d = L/19$
Box Girders, constant depth	$d = L/21$

Post Tensioned Box Girders:	Minimum Depth:
Continuous, uniform depth	$d = L/29$

Precast Prestressed Concrete Superstructures:	Minimum Depth:
Slabs and Boxes	$d = L/40$
Deck Bulb-T Girders	$d = L/33$
Bulb-I and Bulb-T girders	$d = L/25$

d = depth of constant depth members or depth at midspan of haunched member.

L = span length between centerlines of bearings for a simple span bridge or longest span between centerlines of bents for a continuous span bridge

Increase depths for simple span bridges by 10 percent.

Depths shown for are for constant-depth sections. Depth at midspan of haunched members may be reduced 15 percent for beams with continuous parabolic haunches or with straight haunches equal to 1/4 the span where the total depth at the haunch is 1.5d.

Where minimum depth requirements, given above, are satisfied, the optional live load deflection criteria in *LRFD 2.5.2.6.2* will not be required. When minimum depth requirements are not satisfied, verify that the live load deflection does not exceed the limits recommended in *LRFD 2.5.2.6.2*.

When both minimum depth and live load deflection requirements are not satisfied, submit a request for a design deviation (see *BDM 1.2.2*). As justification for the request, document girder and deck service stress levels, live load deflection, and provide evidence of similar structures already in service with satisfactory performance.

(3) Girder Spacing

Girder spacing is normally dependent on girder capacity. As span length increases, girder spacing should decrease. Limit deck overhangs to no more than one-half the girder spacing. Long deck overhangs tend to sag over time (even decks post-tensioned transversely).

### 2.5.3 Bridge Length

#### (1) General

Determine the bridge length by referring to the following as applicable:

- *BDM 1.11.2.1*, “Determining Bridge Length”
- Bridge Standard Drawing *BR115*, “Standard Slope Paving”
- *BDM 3.14.7.2*, “Hydraulic Requirements for Stream Crossings”
- *BDM 3.14.11.3*, “Railroad Clearances”
- *BDM 3.14.8*, (Wildlife passage requirements that may add structure length)
- Following Subsections (2) and (3)

#### (2) Width and Cross Section of Lower Roadway

For horizontal clearances, see *BDM 3.14.4.2*. Choose the back-slopes as follows:

- Use 2:1 end fill slopes for all bridges unless the Geotechnical designer recommends otherwise.
- 1.5:1 end fill slopes are common for county roads and less-traveled highways. Review the ODOT *Highway Design Manual Figure 4-1*, “Standard Sections for Highways Other Than Freeways”, but do not use a slope steeper than 2:1 unless a steeper slope is recommended in the Geotechnical Report.

#### (3) Stock Paths at Stream Crossings

Provisions for stock to cross the roadway should be located away from the bridge crossing to reduce concentration of pollutants in the stream. However, if a stock path running under the bridge parallel to the stream is required, additional bridge length will be needed to accommodate:

- Sufficient horizontal space and vertical clearance to construct a benched section for a path above ordinary high water
- A fence to keep stock out of the stream

Stock passes are also discussed in the ODOT *Highway Design Manual*.

### 2.5.4 Substructure Guidance

Read the *Geotechnical Report* for information and recommendations about type of foundation required, or talk to the Geotechnical Designer if the *Geotechnical Report* is not yet available. For stream crossings, recommendations for scour and riprap protection are contained in the *Hydraulics Report*.

### 2.6 SAFETY AND ACCESSIBILITY REQUIREMENTS

#### [2.6.1 Uniform Accessibility Standards](#)

#### [2.6.2 Inspection and Maintenance Accessibility](#)

#### **[2.6.1 Uniform Accessibility Standards](#)**

The Uniform Accessibility Standards are to be used for the design of all Federal-Aid projects.

Design pedestrian overpass and underpass ramps to not exceed a 1:12 grade, and platforms located every 30 feet. Design other features such as handrails and stairs to comply with the standards. Obtain design deviations on a case-by-case basis, if justified.

For pedestrian structures, use FHWA publication *Guidelines for Making Pedestrian Crossing Structures Accessible* (FHWA-I-84-6).

##### (1) Wingwall and MSE fill slopes

Provide fall protection for wingwall and MSE fill slopes whenever the potential vertical drop exceeds 10 feet. Fall protection may consist of one of the following:

- Roadway barrier at the top of the slope may be considered adequate protection for the public in most cases. However, when the vertical drop at the face of the wall exceeds 15 feet, provide additional protection (safety cable, cable fencing, or chain link fencing) at the top of the wall.
- Safety cable at the top of the wall may be adequate when the slope is not accessible by the public, but access by maintenance personnel or bridge inspectors is anticipated.
- Provide cable fencing when no roadway barrier has been provided at the top of the slope and the slope is accessible to the public. Where a sidewalk is provided at the top of the slope without roadway barrier between the sidewalk and slope, the slope should be considered accessible to the public.
- Provide chain-link fencing or hand railing when pedestrian, maintenance or inspection access is provided adjacent to the top of wall.

Seek concurrence from the Region Safety Manager concerning the specific wall slope protection proposed.

Provide fall protection that is aesthetically appropriate for the site. In many cases, this may involve extending the system along the full length of the wall even though portions of the wall may have less than 10 feet of vertical drop.

##### (2) Design Criteria for safety cable

Design safety cable and cable fencing using the following criteria:

- Use 1/2" diameter galvanized wire rope with an independent wire rope core and having a minimum breaking strength of 26,000 pounds.
- Use galvanized cable connections and turnbuckles having a minimum ultimate strength at least as great as the cable strength.

- For cable fencing, provide a minimum of two cables with the top cable 36 inches high and the other cables evenly spaced.
- Space cable supports or posts at 10 feet or less.
- Design the cable support system to resist a vertical service load of 3000 pounds (5000 pounds ultimate) anywhere along the length of the cable.
- Design end posts and cable end connections to resist the minimum breaking strength of the cable. End posts for cable fencing need only be designed considering one cable loaded at a time.

### **2.6.2 Inspection and Maintenance Accessibility**

FHWA mandates that bridges be inspected every 24 months. Inspectors are required to access bridge components to within 3' for visual inspection and to access bearings close enough to measure movement. Maintenance personnel need to access damaged members and locations that may collect debris. Be aware of these requirements and prepare designs that allow access for bridge inspectors and maintenance personnel, and possible bearing replacement.

Such facilities should meet the *Oregon Occupational Safety and Health Code Chapter 437 Rules [Division 2, General occupational safety and health Subdivision D, Walking-Working Surfaces](#)*.

For bridge rail height requirements related to inspection and maintenance, see *BDM 1.13.1.11* "Design Standards" and *BDM 1.13.1.3*, "Vehicular Railing".

Inspection walks must clear all required minimum clearances under the structure and cannot infringe or reduce minimum required waterway openings.

Provide inspection walks with sufficient headroom and width for inspection personnel to carry bulky equipment between walk rails without difficulty.

Consider inspection walks for wide and high bridges where the reach of the arm of an inspection crane is not long enough for proper inspection and maintenance of the bridge members.

Consider inspection walks combined with other facilities such as ladders, manholes and safety cables. Consider all critical areas that require close inspection such as fracture critical members, hinges, splices, hangers, expansion joints, bearings, utility lines, navigation lights, and areas that require frequent maintenance.

FHWA has recommended maintenance walkways between all steel girders. This has proven to be a costly item and should be reviewed on a case-by-case basis. These were provided on the Santiam River Bridge (Steel Alternate) Bridge 08123D, Drawing 47448. The detailed W5x15 walkway beams are not readily available. A W8x18 alternate is recommended, as this was substituted on the John Day River Bridge, Bridge 00108D.

#### **2.6.2.1 Vertical Abutments and MSE Abutments**

Provide access for inspection of bearings and shear lugs. Provide access consisting of the following:

- 3'-0" minimum walkway width - This is the clear width available for an inspector or maintenance worker to walk as needed for inspection and maintenance of bearings, shear lugs and backwalls.

- 4'-0" minimum height - This is the minimum height from the walkway surface to the bottom of girder. For bridges having a solid bottom, such as a concrete box girder, provide 5'-0" minimum.
- Safety Railing or Cable - Provide either safety railing or a safety cable. When a safety cable is used, attach the cable to either the backwall or cap (approximately 4 feet above the top of walkway) or to the bottom of the girders. Note that attachment to precast prestressed girders must be limited to the center 4 inches of the bottom flange. Locate the cable at least 2'-0" horizontal distance away from the vertical drop. Design the safety cable system using the criteria given in *BDM 2.6.1(2)*. Alternatively, standard drawings *BR190* and *BR191* "Horizontal Fall Arrest Lifeline" details are now available. Where potential maintenance activity can be anticipated, such as replacement of bearings, locate the cable to avoid interference with potential bearing replacement and girder jacking operations. Where safety railing is used, design railing to be removable in sections to facilitate maintenance work.
- Access to the walkway - Provide access to the walkway using one of the following:
  - 3'-0" wide walkway along the top of the wingwall. Provide a safety cable or safety railing when the vertical drop exceeds 10 feet.
  - Cast-in-place steel U-bar ladder steps from the ground level (under the bridge) up to the maintenance walkway. In urban environments, place the first U-bar ladder step approximately 12 feet from the ground. Access to this first step will be by portable ladder. Ensure there is an adequate bench for the ladder to seat.
- Security - For bridges in urban environments, use deterrent fencing and provide locked gates at each entrance to the walkway. Design fencing to be removable in sections to facilitate maintenance work. See *BDM 2.7.1*, "Bridge Design Security Considerations".

When the height from the ground to the bearings is 15 feet or less, inspection and/or maintenance can be performed with a ladder. If so, ensure there is a 5'-0" minimum bench at the top of slope to support a portable ladder. Where such a bench is not practical, provide cast-in-place steel U-bar ladder steps. Provide enough ladder steps so that an inspector is able to get within 3'-0" of any bearing.

#### 2.6.2.2 Semi-integral and Integral Abutments

Provide access for inspection of bearings and shear lugs. When integral abutments are used, provide access for inspection of backwalls.

The minimum clearance between the bottom of the superstructure and the embankment below shall be 3'-0" for girder bridges and 5'-0" for bridges having a solid bottom, such as a concrete box girder, when bearing access is required. When bearing access is not required, minimum clearance shall be 2'-0".

#### 2.6.2.3 Bridge Superstructures

ODOT policy is to use mobile access equipment for inspection and maintenance work whenever feasible. Fall arrest cable systems are recommended for bridges where access for inspection and maintenance is not feasible using snooper cranes or manlifts.

Provide permanent access to all cells of concrete box girders for utility access, inspections or other purposes. (See *BDM 1.5.7.6*)

### 2.7 BRIDGE SECURITY DESIGN CONSIDERATIONS

#### [2.7.1 Bridge Security Design Considerations](#)

#### [2.7.2 Placing Building Beneath ODOT Bridges](#)

#### **[2.7.1 Bridge Security Design Considerations](#)**

##### **2.7.1.1 General**

Consider project-specific countermeasures during the Scoping Phase for those structures which ODOT management determines need specific attention.

Potential bridge security threats include: “carried and placed” bombs, vehicle bombs, intentional vehicle or ship collisions, intentional fires, and other intentional and unintentional threatening activities. This section tells when and how to consider potential bridge security threats during the design of:

- New bridges
- Bridge widenings
- Bridge rehabilitation projects

##### **2.7.1.2 Countermeasures**

Four countermeasures can help protect structures against potential security threats.

##### ***Deter, Deny, Detect, Defend...***

**Deter:** Prevent an aggressor from attacking the structure by making the security presence known such as police or other authorized personnel.

**Deny:** Prevent an aggressor from entering an unauthorized zone by a physical barrier such as security fencing, secure hatches or locked doors.

**Detect:** Observe unauthorized personnel in a restricted area by means such as cameras or sensors.

**Defend:** Provide ‘hardening’ measures to protect a component from attack.

##### **2.7.1.3 Process**

Assess the probable structure specific security risks:

- Remote,
- Possible,
- High, or
- Critical

**Remote:** Only applies to structures on remote, low volume AADT facilities. Implementation of security countermeasures normally not warranted.



Possible: Applies to structures on the non-freeway State Highway System. Consider implementing security countermeasures associated with Deterring and Denying access to the structure. Ideas to consider include:

- Locate box girder soffit access openings away from abutments requiring a ladder or other mechanical means to gain access
- Provide shielded locking mechanisms on all access openings
- Place secure screens at soffit vents near abutments
- Prevent access to maintenance walkways and girder flanges at abutments
- Post warning signs on the bridge approaches and below the structure
- Deny access to critical structural components
- Prevent vandalism, graffiti artists, or camping

High: Applies to structures on the Interstate Highway System. Consider implementing security countermeasures associated with Deterring, Denying, Detecting, and Defending the structure. In addition to the items listed under 'Possible', include the following:

- Establish guidelines for standoff distance
- Eliminate access to small confined spaces

Critical Structures: These are structures that have been determined to be the most vulnerable structures in the State of Oregon.

Some bridges, due to their complex and unique nature, will require project-specific countermeasures along with those countermeasures that apply to all structures. These are bridges considered "critical" to the transportation network. The most critical bridges will also require site-specific operational security plans. The ODOT Emergency Preparedness Committee identified critical bridges and their potential vulnerabilities. To find out more, contact the Statewide Emergency Operations Manager in the ODOT Office of Maintenance and Operations.

Consider the need for security countermeasures during the Scoping Phase to ensure that added costs are included in the project budget. Define countermeasures and security plans and include in the TS&L Report. The Bridge Designer is to consult with the ODOT Bridge Operations & Standards Managing Engineer for security guidance and to maintain consistency statewide.

If the Bridge Operations & Standards Managing Engineer decides a critical bridge needs specific mitigation measures, consider these strategies first:

- Locate piers and towers so vehicular access is prevented.
- Design redundancy with critical elements.
- Place barriers to provide standoff distance when critical structural elements cannot be located away from vehicular traffic. If this cannot be achieved, the critical structural member or mechanical system should be analyzed and hardened against the design threat.
- Install locks, caging, and fencing to deny access to key points of vulnerable structural and mechanical systems.
- Install motion detectors or security cameras, and plan for communications to security response entities, to minimize "time-on-target."

When cost-effective, consider selective protection of the structural integrity of key members against collapse. Ways to do this include strengthening key substructure members, adding redundancy, and use of blast hardening.

Again, consider project-specific countermeasures during the Scoping Phase for those structures which ODOT management determines need specific attention.

### 2.7.2 Placing Buildings Beneath ODOT Bridges

The placement of buildings beneath ODOT bridges is strongly discouraged. However, if local public agencies request and are given approval to place buildings below ODOT bridges, satisfy the following requirements:

- Maintain the structural integrity of the bridge:
  - Shore excavations that extend below the bottom of bridge footings adjacent to the proposed building according to Standard Specifications *SP 00510.44*.
  - Replace any soil removed within the vicinity of a bridge footing and compact according to Standard Specifications *SP 00510.46(a)*.
- Bridge maintenance provisions:
  - Provide 10 feet of vertical clearance between roof and superstructure for operation of snooper cranes, or for hanging scaffolds; or
  - Design the building's roof system to act as a work platform for maintenance or construction activities. Provide 3 feet minimum vertical clearance between roof and superstructure. Design the roof sheathing and purlins for a working load of 250 pound point load or 100 psf, whichever controls. Extend the design area 10 feet beyond the shadow of the structure. Design members below the purlin level for a working load of 50 psf over an area of 10' x 20'.
- Future seismic retrofit provisions:
  - Place the building to allow for increasing the size of the existing footing or footings by 50 percent plus an allowance of 5 feet for work area.
  - Make the building owners aware that future footing excavations or pile driving could cause vibrations in the building with a potential for damage to the building or contents. And that the State will not be responsible for any damage to the building or contents caused by such construction.
- Future bridge replacement or widening provisions:
  - Evaluate the need for a new bridge or future widening of the bridge. If the potential exists, allow for increasing the bridge width and construction of new footings. Allow 5 feet around the future footings for work area.
  - Make the building owners aware that future footing excavations or pile driving could cause vibrations in their building with a potential for damage to the building or contents. And that the State will not be responsible for any damage to the building or contents caused by such construction.
- Falling object protection:
  - Place protective fencing on the bridge above the building to cover the limits of any ground activity below the bridge.
  - Make the building owners aware that the State will not be responsible for any damage to the building or content caused by falling objects.

- Bridge fire protection:
  - The building shall be constructed of non-flammable materials and be equipped with an automatic sprinkler system.
  - The building shall not be used to store large quantities of flammable materials.
- Right of Access:
  - ODOT and or contractor employees shall be given access to the property and/or building as needed to perform any construction or maintenance activities.

Submit proposals to the District Manager and the Bridge Operations & Standards Managing Engineer for review and approval. Include a drawing or drawings showing the existing bridge with all pertinent members dimensioned, and showing the proposed building with all pertinent dimensions, clearances, materials and roof design loads. The drawing or drawings shall be prepared, signed, and stamped with a seal of an engineer registered to practice in the State of Oregon.

### 2.8 BRIDGE NAME PLATES & MARKERS

#### [2.8.1 Existing Name Plates](#)

#### [2.8.2 Bridge ID Markers](#)

##### [2.8.1 Existing Bridge Name Plates](#)

Specify that existing bridge name plates be salvaged and delivered to the office of the ODOT Construction Project Manager.

##### [2.8.2 Bridge ID Markers](#)

Specify that bridge identification markers be installed at the bridge site by the construction contractor, unless the Region has an arrangement with District Maintenance to install the markers in-house. Show bridge ID marker placement locations in the bridge contract plans (typically on the Deck Plan, Detail Reference Number 81) and incorporate them into the Special Provisions. Bridge ID markers are not part of the project signing and should not be shown in the sign plans.

Place the ID marker at both ends of the bridge, typically in the bridge rail transition, facing on-coming traffic. If the structure is located over another route, place additional bridge identification markers on the face of the bridge bent, immediately adjacent to and on both sides of the under-crossing roadway, facing on-coming traffic.

For mounting in bridge rail transition areas which have timber posts, the bridge ID marker is attached to a cut off Type-1 steel roadway delineator post. The steel post is attached to a guard rail post as shown in “Type-4, Alternate 2” on Standard Drawing TM570. For mounting in rail transition areas which have steel posts, the ID marker is attached to a full height Type-1 steel delineator post which is driven alongside a transition post. On vertical concrete faces, the ID markers are mounted using stainless drilled mechanical anchors from the QPL. Boilerplate *SP 00842* “Facility Identification Markers” includes these mounting instructions for the contractor.

Configure each ID marker in accordance with the example and information below. Show this information in a table in the bridge plans (see MicroStation cell “T\_BridgeID\_Marker” ). Standard Drawing *BR195* shows dimensions, text, colors and other requirements of the marker for inclusion in the contract plans. For state owned bridges, telephone numbers for the appropriate dispatch can be found at <https://www.oregon.gov/ODOT/Pages/Report-Hazard.aspx>. Note that dispatch center boundaries may not correspond to Region boundaries.

Telephone number of the appropriate agency Dispatch Center  
US or OR Route Number  
State Highway Number  
Milepoint Number  
Bridge Number  
Name of the Structure

