

Model ATC Controller

DRAWER

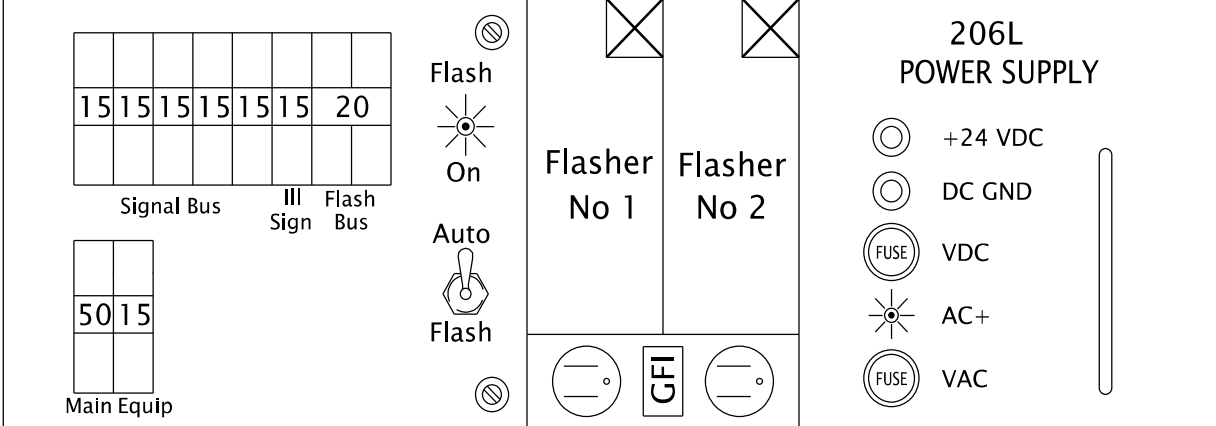

Power Distribution Assembly #2

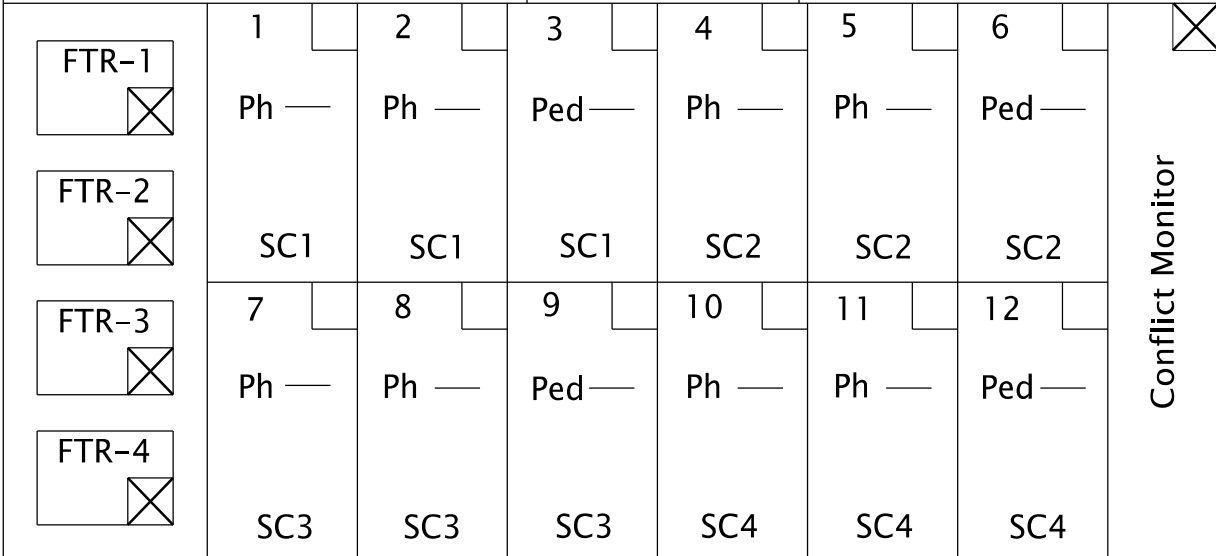

Output File

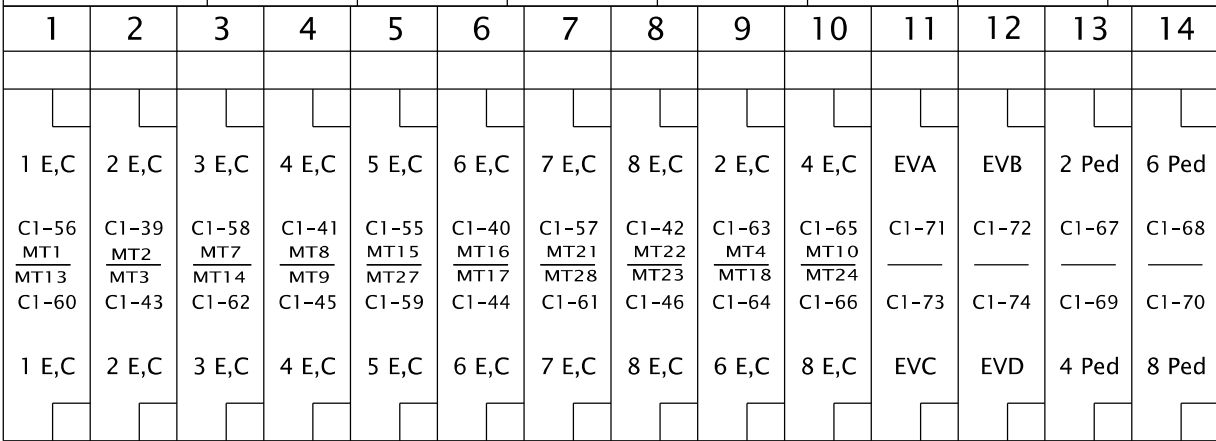

Channel 1

INPUT FILE

Channel 2

REV. NO.	DATE	INITIAL	REMARKS	INTERSECTION:	Main Street @	OREGON DEPARTMENT OF TRANSPORTATION
1	MM/YY	XXX	DRAFT	Cross Street	Any Town	TRAFFIC - ROADWAY SECTION
				HWY*: XXX M.P.*:XXX.XX	TSSU ID*:XXXXX	336S CABINET WIRING DIAGRAM
						REV 05/26/21

W4IKS PROGRAM PIN ASSIGNMENTS

Program Assigned Functions	C1 Connector		C4 Connector				Field Term.
	Pin	Termination	Pin	Switch Pack			
				In	Position	Out	
DC Gnd	1	DC Gnd Bus	-	-	-	-	-
Ø4 D. WALK	2	C4-1	1	6	6-DW	3	104
Ø4 WALK	3	C4-2	2	10	6-W	7	106
Ø4 RED	4	C4-3	3	6	5-R	3	101
Ø4 YELLOW	5	C4-4	4	8	5-Y	5	102
Ø4 GREEN	6	C4-5	5	10	5-G	7	103
Ø3 RED	7	C4-6	6	6	4-R	3	116
Ø3 YELLOW	8	C4-7	7	8	4-Y	5	117
Ø3 GREEN	9	C4-8	8	10	4-G	7	118
Ø2 D. WALK	10	C4-9	9	6	3-DW	3	113
Ø2 WALK	11	C4-10	10	10	3-W	7	115
Ø2 RED	12	C4-11	11	6	2-R	3	128
Ø2 YELLOW	13	C4-12	12	8	2-Y	5	129
Input Gnd	14	T15-3	-	-	-	-	-
Ø2 GREEN	15	C4-13	13	10	2-G	7	130
Ø1 RED	16	C4-14	14	6	1-R	3	125
Ø1 YELLOW	17	C4-15	15	8	1-Y	5	126
Ø1 GREEN	18	C4-16	16	10	1-G	7	127
Ø8 D. WALK	19	C4-17	17	6	12-DW	3	110
Ø8 WALK	20	C4-18	18	10	12-W	7	112
Ø8 RED	21	C4-19	19	6	11-R	3	107
Ø8 YELLOW	22	C4-20	20	8	11-Y	5	108
Ø8 GREEN	23	C4-21	21	10	11-G	7	109
Ø7 RED	24	C4-22	22	6	10-R	3	122
Ø7 YELLOW	25	C4-23	23	8	10-Y	5	123
Ø7 GREEN	26	C4-24	24	10	10-G	7	124
Ø6 D. WALK	27	C4-25	25	6	9-DW	3	119
Ø6 WALK	28	C4-26	26	10	9-W	7	121
Ø6 RED	29	C4-27	27	6	8-R	3	134
Ø6 YELLOW	30	C4-28	28	8	8-Y	5	135
Ø6 GREEN	31	C4-29	29	10	8-G	7	136
Ø5 RED	32	C4-30	30	6	7-R	3	131
Ø5 YELLOW	33	C4-31	31	8	7-Y	5	132
Ø5 GREEN	34	C4-32	32	10	7-G	7	133
(A)TOD/DOW	35	C4-33	33	8	3-Y	5	114
(B)TOD/DOW	36	C4-34	34	8	9-Y	5	120
(C)TOD/DOW	37	C4-35	35	8	6-Y	5	105
(D)TOD/DOW	38	C4-36	36	8	12-Y	5	111

Program Assigned Functions	C1 Connector		Input File		
	Pin	Termination	Terminals		
			Out	In	
Ø2 DET,E&C	39	I2-F	F	D&E	-
Ø6 DET,E&C	40	I6-F	F	D&E	-
Ø4 DET,E&C	41	I4-F	F	D&E	-
Ø8 DET,E&C	42	I8-F	F	D&E	-
Ø2 DET,E&C	43	I2-W	W	J&K	-
Ø6 DET,E&C	44	I6-W	W	J&K	-
Ø4 DET,E&C	45	I4-W	W	J&K	-
Ø8 DET,E&C	46	I8-W	W	J&K	-
Ø2 DET, C	47	I2-SP	-	-	-
Ø6 DET, C	48	I6-SP	-	-	-
Ø4 DET, C	49	I4-SP	-	-	-
Ø8 DET, C	50	I8-SP	-	-	-
Ped Inhib	51	I9-SP	-	-	-
RR Preempt	52	I10-SP	-	-	-
Adv. Enable	53	I11-SP	-	-	-
Not Assigned	54	I13-SP	-	-	-
Ø5 DET,E&C	55	I5-F	F	D&E	-
Ø1 DET,E&C	56	I1-F	F	D&E	-
Ø7 DET,E&C	57	I7-F	F	D&E	-
Ø3 DET,E&C	58	I3-F	F	D&E	-
Ø5 DET,E&C	59	I5-W	W	J&K	-
Ø1 DET,E&C	60	I1-W	W	J&K	-
Ø7 DET,E&C	61	I7-W	W	J&K	-
Ø3 DET,E&C	62	I3-W	W	J&K	-
Ø2 DET,E&C	63	I9-F	F	D&E	-
Ø6 DET,E&C	64	I9-W	W	J&K	-
Ø4 DET,E&C	65	I10-F	F	D&E	-
Ø8 DET,E&C	66	I10-W	W	J&K	-
Ph 2 Ped	67	I13-F	F	D	-
Ph 6 Ped	68	I14-F	F	D	-
Ph 4 Ped	69	I13-W	W	J	-
Ph 8 Ped	70	I14-W	W	J	-
EVA	71	I11-F	F	D	-
EVB	72	I12-F	F	D	-
EVC	73	I11-W	W	J	-
EVD	74	I12-W	W	J	-
Not Assigned	75	I14-SP	-	-	-
Ø2 DET, E	76	I5-SP	-	-	-
Ø6 DET, E	77	I5-SP	-	-	-
Ø4 DET, E	78	I3-SP	-	-	-
Ø8 DET, E	79	I7-SP	-	-	-
Advance	80	I12-SP	-	-	-
Flash Sense	81	TB02-4	-	-	-
Stop Time	82	TB02-3	-	-	-

Program Assigned Functions	C1 Connector	
	Pin	Termination
Ø3 D. Walk	83	NC
Ø3 WALK	84	NC
OLD RED	85	NC
OLD YELLOW	86	NC
OLD GREEN	87	NC
OLC RED	88	NC
OLC YELLOW	89	NC
OLC GREEN	90	NC
Ø1 D. Walk	91	NC
DC Gnd	92	DC Gnd Bus
Ø1 WALK	93	NC
OLB RED	94	NC
OLB YELLOW	95	NC
OLB GREEN	96	NC
OLA RED	97	NC
OLA YELLOW	98	NC
OLA GREEN	99	NC
Not Assigned	100	NC
Not Assigned	101	NC

Flash Output	102	NC
Watchdog	103	C4-37
Input Gnd	104	DC GND BUS

Monitor-Pin 22

CONFLICT MONITOR UNIT

Connector Pin Assignments

Term	Function	Pin	Channel Assignments (Typical)	Pin	Function	Term
130	SP2-G	1		A	SP2-Y	129
115	SP3-W	2		B	SP8-G	136
135	SP8-Y	3		C	SP9-W	121
103	SP5-G	4		D	SP5-Y	102
106	SP6-W	5		E	SP11-G	109
108	SP11-Y	6		F	SP12-W	112
133	SP7-G	7		H	SP7-Y	132
	T&B	8		J	SP1-G	127
126	SP1-Y	9	Ch	Ph	K	T&B
124	SP10-G	10	1 • 1	L	SP10-Y	123
	T&B	11	2 • 2	M	SP4-G	118
117	SP4-Y	12	3 • 3	N	T&B	
A123	ASP1-G	13	4 • 4	P	NC	-
-	NC	14	5 • 5	R	ASP2-G	A126
	T&B	15	6 • 6	S	ASP4-G	A116
	T&B	16	7 • 7	T	NC	-
-	NC	17	8 • 8	U	T&B	
	T&B	18	9 • OLA	V	ASP5-G	A103
-	NC	19	10 • OLB	W	NC	-
TB01-9	Eq Gnd	20	11 • OLC	X	NC	-
TB01-10	AC-	21	12 • OLD	Y	DC Gnd	TB02-2
C4-37	Watch Dog	22	13 • Ped 2	Z	Ext. Reset	TB02-5
TB02-1	+24VDC	23	14 • Ped 4	AA	T&B	
LRCoil	Interlock	24	15 • Ped 6	BB	Stop Time	TB02-3
TB02-2	Interlock	25	16 • Ped 8	CC	NC	-
-	NC	26		DD	NC	-
-	NC	27		EE	Clapper	TB01-12
TB01-11	Norm. Closed	28		FF	AC+	TB01-11

T&B = Tied and Bundled

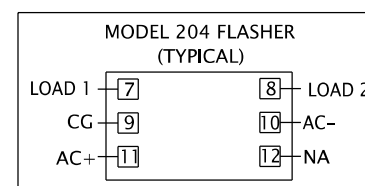
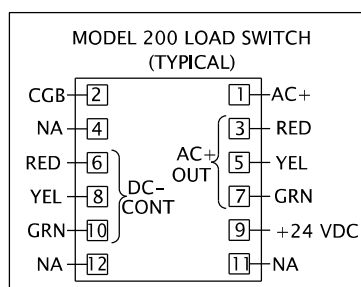

OUTPUT FILE C1 PIN DESIGNATIONS

SWPK 1	SWPK 2	SWPK 3	SWPK 4	SWPK 5	SWPK 6	
C1-16	C1-12	C1-10	C1-7	C1-4	C1-3	RED
C1-17	C1-13	C1-35	C1-8	C1-5	C1-37	YELLOW
C1-18	C1-15	C1-11	C1-9	C1-6	C1-4	GREEN
SWPK 7	SWPK 8	SWPK 9	SWPK 10	SWPK 11	SWPK 12	
C1-32	C1-29	C1-27	C1-24	C1-21	C1-19	RED
C1-33	C1-30	C1-36	C1-25	C1-22	C1-38	YELLOW
C1-34	C1-31	C1-28	C1-26	C1-23	C1-20	GREEN

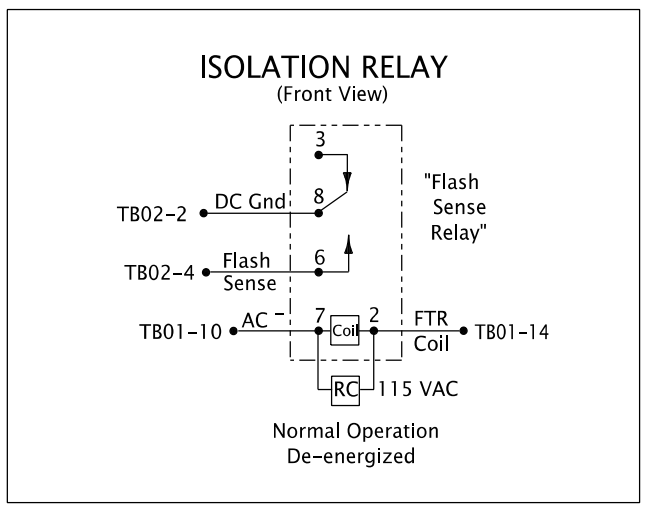
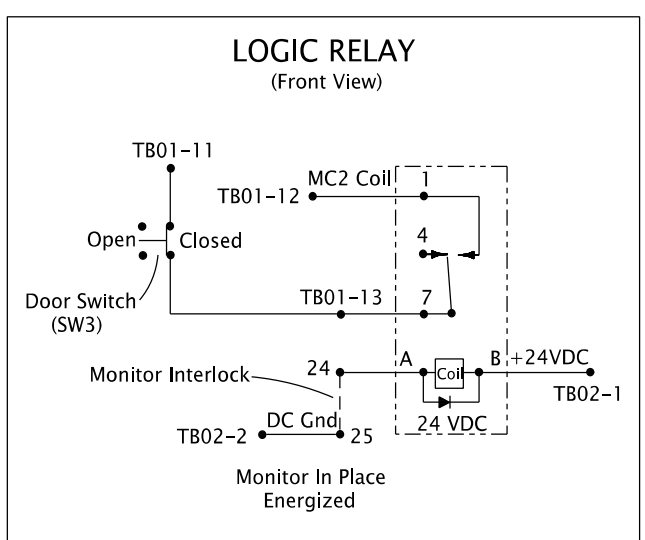
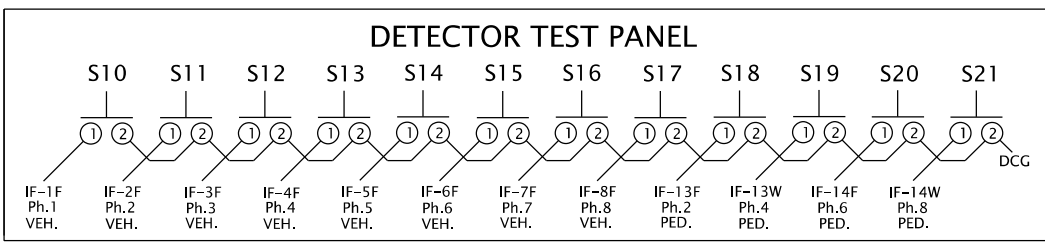
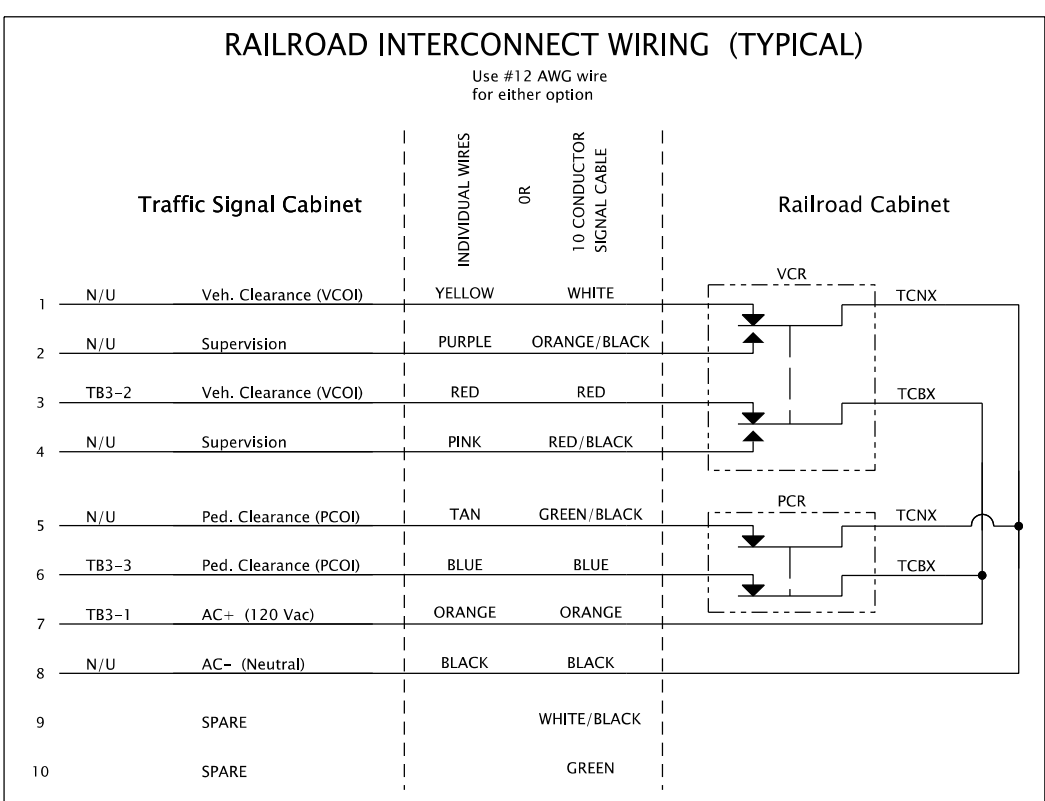
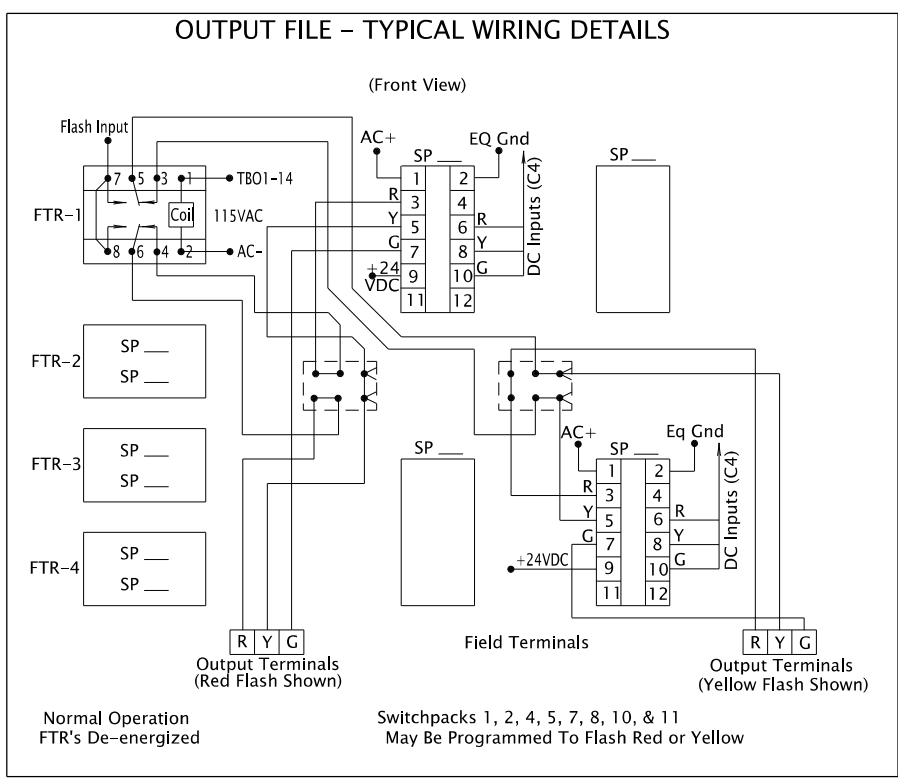
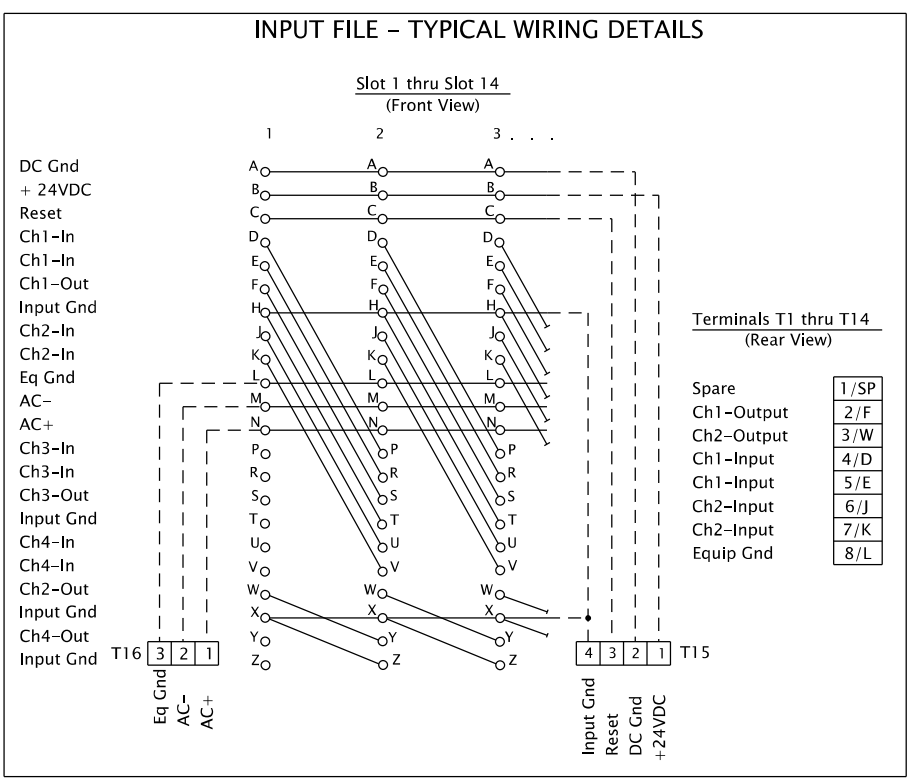
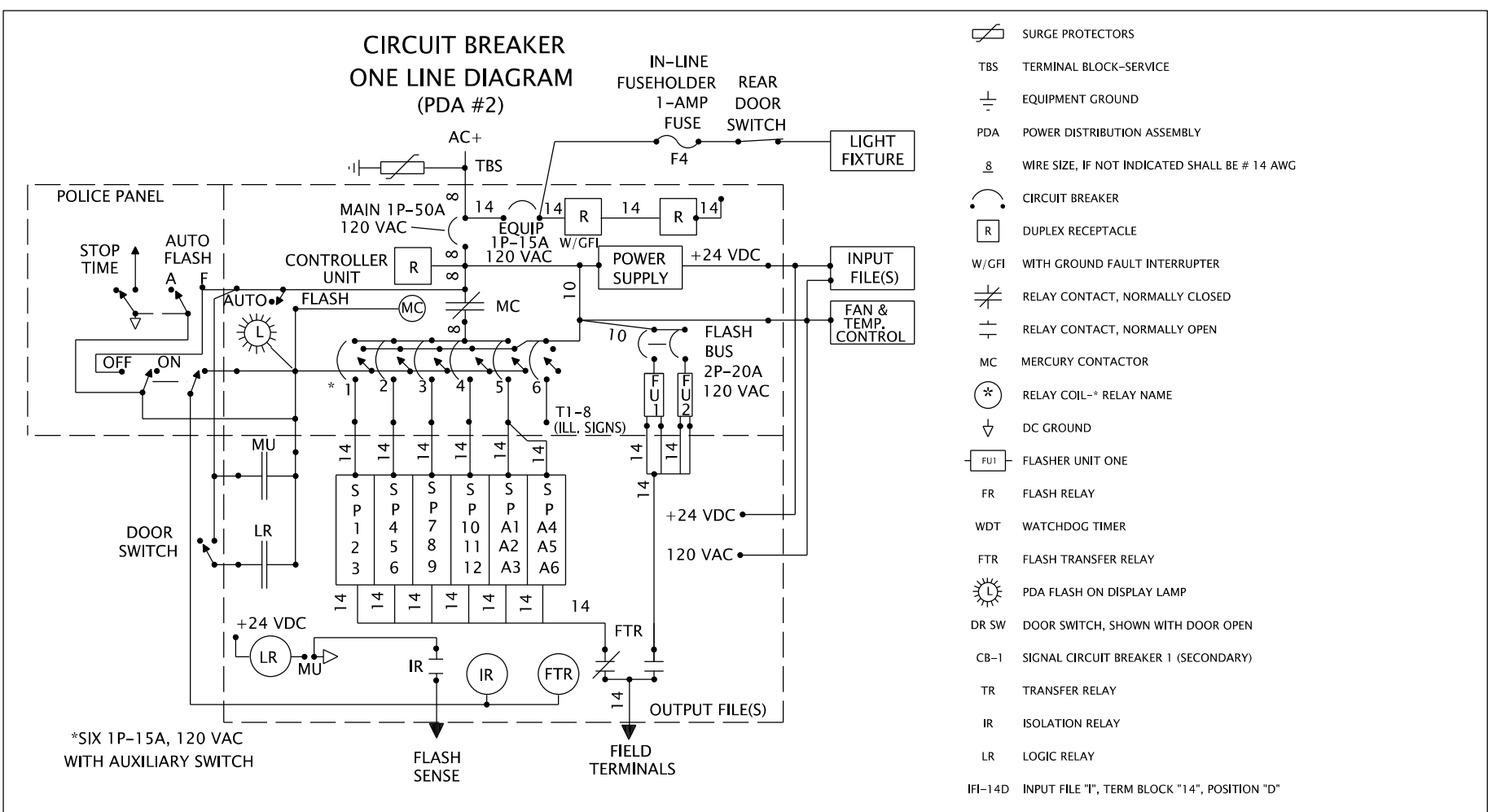

INTERSECTION DIAGRAM

NOTE:

- 1. FILL IN CHANNEL ASSIGNMENTS WITH PHASING. Ch.1 Ph 1,Ph 5,OLA,Ped 2,NU
- 2. REMOVE YELLOW INHIBIT JUMPERS —————
- 3. REMOVE DIODES FOR ALLOWED PHASING. ———
- 4. PLACE CIRCLE AROUND REMOVED DIODES. ○

CONFLICT MONITOR DIODE CARD

CHANNEL ASSIGNMENT

Ch.1 <u>Ph 1</u>	Ch.5 <u>Ph 5</u>	Ch.9 <u>Ph 3 FYA/YA</u>	Ch.13 <u>Ped 2</u>
Ch.2 <u>Ph 2</u>	Ch.6 <u>Ph 6</u>	Ch.10 <u>NU</u>	Ch.14 <u>Ped 4</u>
Ch.3 <u>Ph 3</u>	Ch.7 <u>Ph 7</u>	Ch.11 <u>NU</u>	Ch.15 <u>Ped 6</u>
Ch.4 <u>Ph 4</u>	Ch.8 <u>Ph 8</u>	Ch.12 <u>PH 7 FYA/YA</u>	Ch.16 <u>Ped8</u>

YELLOW INHIBIT JUMPERS

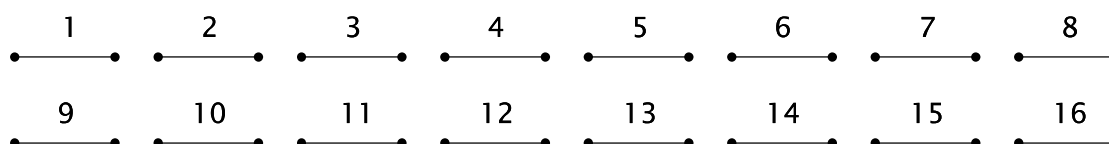

DIODES - Diode Removed Makes Movement Allowable (Diode IN4148)

