

**Chapter 20**

**Contents**

**20 Cabinet Print** ..... 20-1

20.1 When is a Cabinet Print Required?..... 20-1

20.2 Who is Responsible for Creating a Cabinet Print? ..... 20-1

20.3 Procedure for Producing Cabinet Prints..... 20-2

20.4 Creating the Cabinet Print ..... 20-3

20.5 332S Cabinet Print (Page 1 – Cabinet Layout)..... 20-3

20.6 332S Cabinet Print (Page 2 – Input File)..... 20-4

    20.6.1 Detector Input Location (Signal Timer Responsibility – Use Excel File)..... 20-6

    20.6.2 AC Isolator Location (Signal Timer Responsibility – Use Excel File) ..... 20-8

    20.6.3 DC Isolator Location (Signal Timer Responsibility – Use Excel File) ..... 20-9

    20.6.4 Pedestrian Detector Termination ..... 20-10

    20.6.5 Fire Preemption Detectors (Signal Timer Responsibility – Use Excel File)..... 20-11

    20.6.6 Fire Preemption Detection Termination ..... 20-12

    20.6.7 Detector Input Termination ..... 20-13

    20.6.8 Additional Information about the Input File ..... 20-15

20.7 332S Cabinet Print (Page 3 – Output File) ..... 20-16

    20.7.1 Main Output File (Front View):..... 20-18

    20.7.2 Main Output File (Back View)..... 20-19

    20.7.3 Conflict Monitor Diode Card..... 20-19

    20.7.4 Auxiliary Output File (Front and Back View)..... 20-37

    20.7.5 Additional Information for the Output File ..... 20-38

    20.7.6 Output File & Conflict Monitor Configuration for PHBs..... 20-39

20.8 332S Cabinet Print (Page 4 – C1 Pin Assignments & Test Switch)..... 20-42

20.9 332S Cabinet Print (Page 5 – Electrical Diagrams) ..... 20-43

20.10 332S Cabinet Print (Page 6 – Intersection Drawing) ..... 20-43

20.11 332S Cabinet Print (Page 7 – Detection Drawing) ..... 20-49

20.12 332S Cabinet Print (Page 8 – Railroad Preemption Plan Sheet)..... 20-53

20.13 Background/Reference Information ..... 20-56

20.13.1 Flashing Yellow Arrow and Conflict Monitoring.....20-56

## 20 Cabinet Print

The cabinet print is a schematic representation of the components that are inside the controller cabinet. This schematic is used mainly by TSSU, region electrical crew, and region signal timers.

A hard copy of the cabinet print is required to be in the controller cabinet at all times.

### 20.1 When is a Cabinet Print Required?

A cabinet print is required for all new installations that require a controller cabinet (e.g., a traffic signal, ramp meter, fire signal, TRAWS, etc.), the first stage for temporary signals, and any existing installations that have a controller cabinet that will require a change (addition, deletion, or modification) to the components inside the controller cabinet. Cabinet prints must be accurate for proper maintenance and timing of the intersection.

### 20.2 Who is Responsible for Creating a Cabinet Print?

The signal designer is responsible for creating the initial cabinet print(s). The initial cabinet print should be submitted at DAP, when the basic signal equipment layout and normal phase rotation are known. It is critical that the signal timer has adequate time to review and comment on the detector unit placement and zones (shown on sheet 7) as early as possible in the design process. The cabinet print should be revised as necessary during the design phase based on comments received before the equipment arrives at TSSU for testing (during construction).

The traffic engineering section is responsible for creating the final version of the cabinet print from the red-line as-builts provided by TSSU after installation.

TSSU or region 1 electrical/tech is responsible for reviewing the whole existing cabinet print and reporting any errors, omissions, or modifications needed as part of their regular inspection duties. Anyone using an existing cabinet print should also report any errors or omissions they find. To report, send a red-lined copy of the cabinet print to the traffic engineering section. The traffic engineering section is responsible for updating the final version of the cabinet print.

A cabinet print reflects the conditions shown in the sealed plan sheets and therefore does NOT require a P.E. stamp.

## 20.3 Procedure for Producing Cabinet Prints

An [internal ODOT server folder](#) is used to process the various stages of the cabinet print (from start to final version). Within this server folder there are subfolders which are used to maintain an orderly and clear process for all staff that are involved in the creation, use, and QA/QC of the cabinet print. This process is explained in detail in the READ ME word document on the server folder. See Figure 20-1. Non-ODOT designers do not have access to this folder and should work directly with the state traffic signal engineer when providing cabinet print files.

Figure 20-1 | SCdata Traffic Signals Internal Server Folder for Cabinet Prints

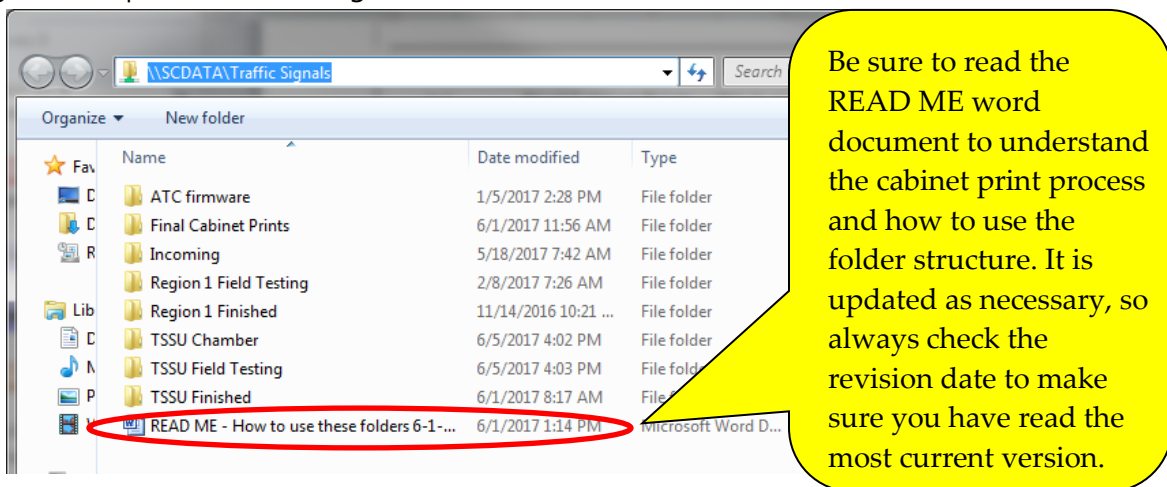

Key information for the signal designer:

1. The cabinet print files (both DGN and PDF) are required in the appropriate INCOMING subfolder **at DAP**. This allows the region signal timer an adequate timeline to review and comment on the non-invasive detection unit and zone placement that are now only shown in the cabinet print (detection zones are no longer shown in the contract plans. See chapter 6 for more information). The signal designer should also address all comments received on cabinet print before the equipment arrives at TSSU (this is typically 2 to 6 months after the project plans are approved. However, a fast-track project may reduce that time to 4 to 8 weeks). Non-ODOT designers should e-mail the files to the state traffic signal engineer who will then place the files in the server folder. Plan accordingly, as failure to produce the cabinet prints in a timely manner may impact the design and construction schedule.
2. The signal designer must contact the region signal timer and request they place the signal timing files within the appropriate INCOMING subfolder. The same time frame described above applies.

If modifications to the cabinet print do NOT match the conditions shown on the most current, sealed plan sheet(s) for the intersection, a new plan sheet is required (as-built).

## 20.4 Creating the Cabinet Print

Each intersection should have its own cabinet print file. The file name should begin with the TSSU ID number and abbreviated intersection name using the highway route number and cross street, for example “04023\_99W\_LewisburgRd”.

The cabinet prints are created in microstation. There are 10 different types of cabinet print base files available on the [traffic signal standards website](#) (click on “microstation cabinet prints”) depending on what type of cabinet is used. Select the correct base file for each intersection on the project:

- |  |  |
|--|--|
| <ul style="list-style-type: none"><li>• 332S cabinet print</li><li>• 332S SDLC cabinet print</li><li>• 332 cabinet print</li><li>• 332 SDLC cabinet print</li><li>• 336S cabinet print</li></ul> | <ul style="list-style-type: none"><li>• 334 ramp meter cabinet print</li><li>• 334 count (ATR) cabinet print</li><li>• 334 SDLC cabinet print</li><li>• 334 TRAWS cabinet print</li><li>• 334 TRAWS SDLC cabinet print</li></ul> |
|--|--|

An excel “detector configuration” file for each cabinet is also required to complete the input file (page 2) and the detection drawing (page 7). The signal timer is responsible for filling out the information correctly in the excel file and the signal designer will import that information into the microstation file. These excel files and additional information is found at the website mentioned above for base files.

The signal designer should also look in the [FINAL CABINET PRINTS folder](#) for existing information before starting a new cabinet print file. A copy of the existing file might be able to be used and modified for the project if the modifications are very minor AND the overall print format/intersection drawing/phase rotation diagrams are in the current format and correct. However, creating a new cabinet print file is required in all other circumstances, such as for a new traffic signal or when replacing an existing cabinet with different style cabinet (e.g., replacing a 332 with a 332S). For signal designers outside of ODOT, contact the traffic engineering section to obtain existing cabinet print information.

When in doubt, create a new cabinet print file when any modifications are needed. The base files on the website are constantly being updated which usually makes it easier/better to use them vs. manipulating the existing file. Just transfer the relevant existing cabinet print information into the new file (which is not very time consuming).

### Traffic-Signal Design Manual – Cabinet Prints

In the microstation base files, the areas that can be modified are typically shown in red. They are populated with the standard phase layout. There are different levels that can be turned on or off depending on the equipment that is installed. Make sure to read the additional instructions for using the DGN files on the website. The typical areas that require modification include:

- The title block identifying information (e.g., intersection name, city, hwy, MP, TSSU ID number, date and revision remarks)
- The input file (front view and side view)
- The input and output file (front view and back view)
- The intersection drawing and the intersection detection drawing

The cabinet print needs to show what is actually used and its intended function. If an area is unused, it should be blank. The other information contained in the cabinet print shows standard electrical schematics that apply to each type of cabinet and are generally not modified.

Cabinet prints are formatted for printing on 11x17 paper.

NOTE! All figures in this manual show a 332S cabinet with a C11 connector. The cabinet print layout for the 332 without a C11 connector, 336, and 334 cabinet will be slightly different, but all contain similar elements. The basic information in this manual can be used in conjunction with the appropriate base file.

# 20.5 332S Cabinet Print (Page 1 – Cabinet Layout)

Page 1 of the 332S cabinet print shows the front, rear, and both side views of the cabinet. There is not a lot to modify on this sheet, but certain levels and/or references will need to be turned-on or off to show the correct site-specific equipment, (e.g., communication equipment, battery back-up, etc.). See Figure 20-2.

Figure 20-2 | 332S Cabinet Print (page 1)

Various equipment on (different levels) can be turned on and off based on site specifics (video detection, communication equipment, etc.). Generally, the info on these levels does not need to be further modified.

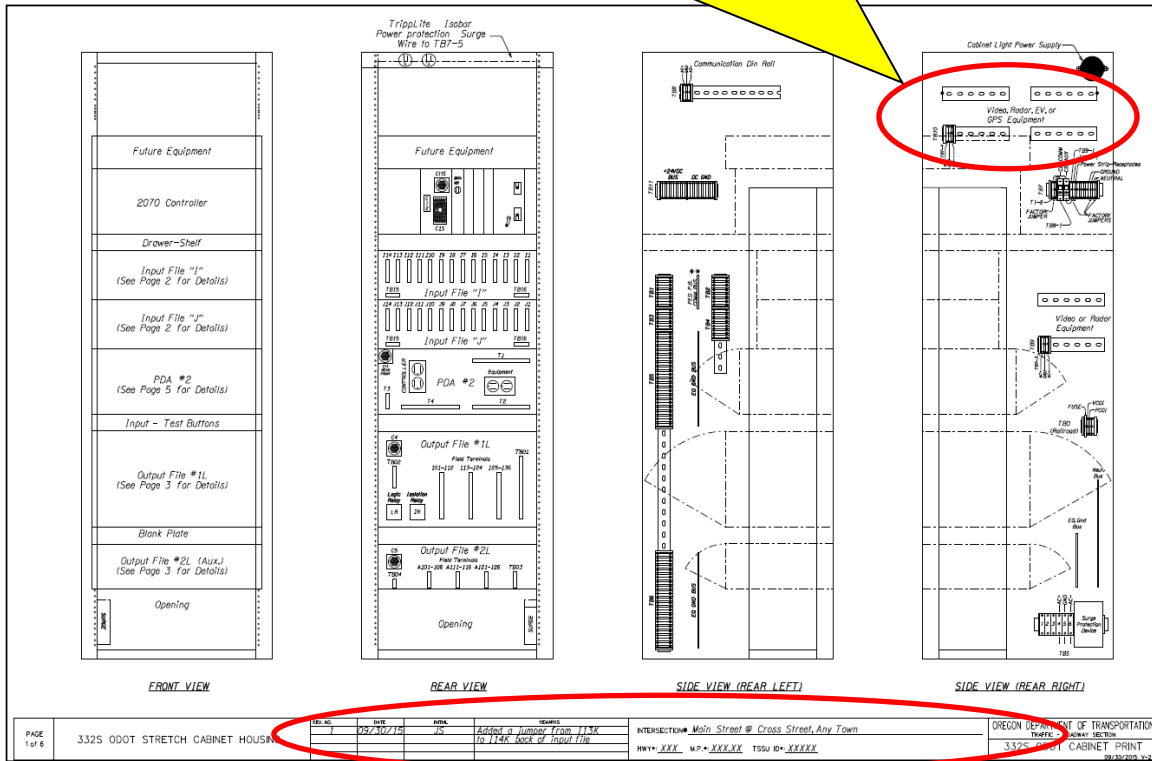

Title block area needs to be filled out as directed

# 20.6 332S Cabinet Print (Page 2 – Input File)

Page 2 of the 332S cabinet print shows the input file. This sheet requires filling in the information for all the input file equipment used. The signal timer is responsible for filling out the majority of the input file information in the detection configuration excel file which is then imported into the microstation cabinet print by the signal designer. See [instructions for signal timers and designers](#) for additional info. The basic input equipment (e.g., loop amplifiers, video rack cards, radar rack cards, DC isolators, AC isolators, fire preemption, etc.) that needs to be filled in is shown in Figure 20-3, with the signal timer’s responsibility shown shaded in blue. Each bubble note in Figure 20-3 is numbered and described in more detail in the next sections. **Important additional information about the input file is in section 20.6.8.**

Figure 20-3 | 332S Cabinet Print (page 2 – Input File)

1.) Detector input location (fill in equipment and modify phase if necessary)

2.) AC isolator location (for RxR preemption)

3.) DC isolator location (for pedestrian detectors)

4.) Ped detector termination (fill in phase)

5.) Fire preemption detectors

6.) Fire Preemption detector termination (fill in phase)

7.) Detector input termination (fill out phase and loop detector number). If loops are not used, leave this area blank.

Signal timer is responsible for providing info (#1, #2, #3, and #5) in excel file. Signal designer then imports excel info into microstation



For reference, Figure 20-4 shows the actual front view of the input file in a 332 cabinet.

Figure 20-4 | 332 Cabinet – Input File (Front View) Actual View

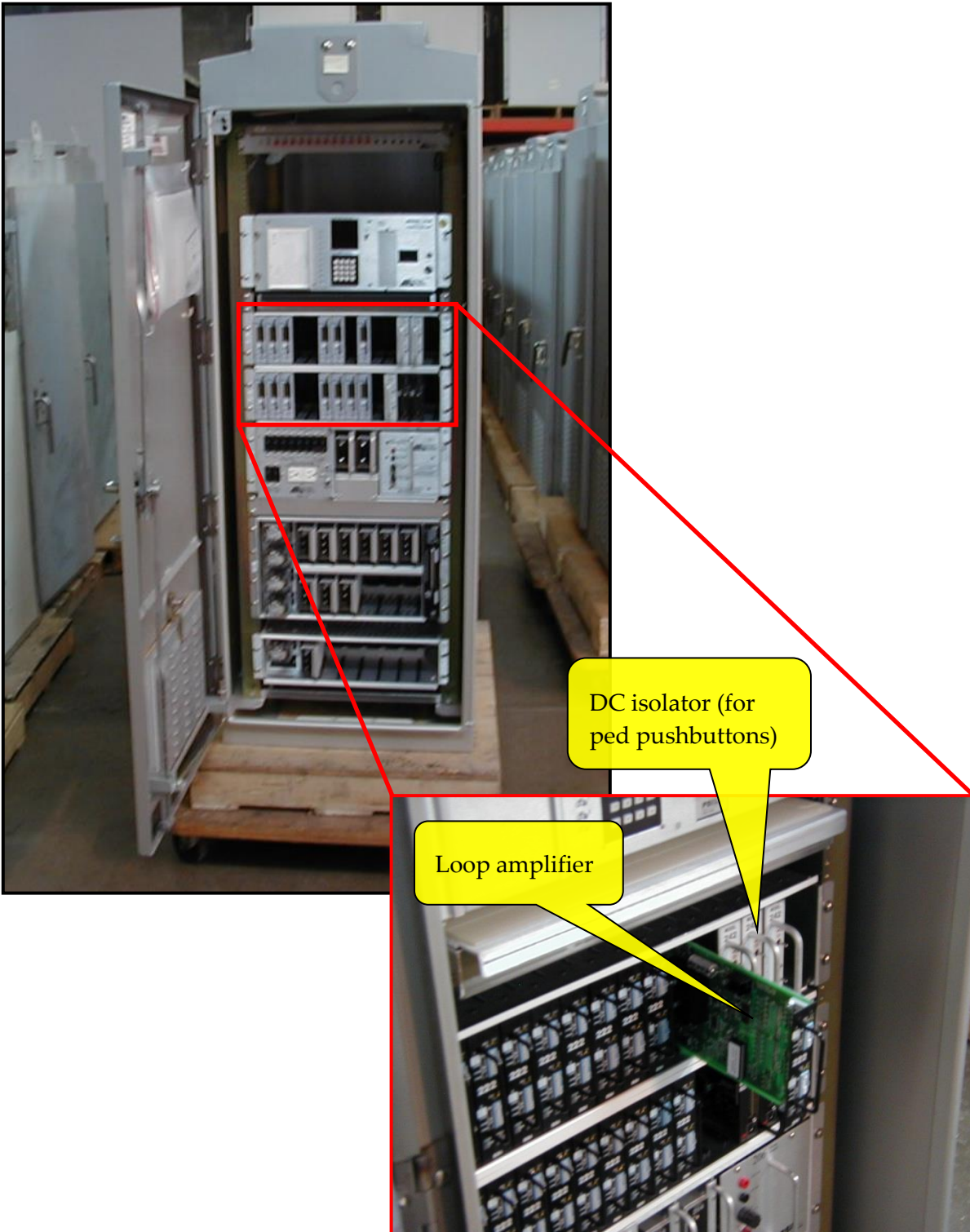

## 20.6.1 Detector Input Location (Signal Timer Responsibility – Use Excel File)

This spans slots one to slot ten (with the possibility of slot eleven and twelve of the “I” file used as needed). When SDLC connection is used, slots 1 thru 10, I11, and I12 will be blank. When SDLC is not used, equipment will be placed in the input file (for loops, video, radar, etc.). The example shown in Figure 20-5 below shows where the signal timer will fill in the information (using the detector configuration excel file which automates the majority of items shown below).

Figure 20-5 | 332 Cabinet – Vehicle Detector Equipment

Equipment goes in the first row below the slot location. The 4 I/O for camera C spans two slots

Check mark the box if the slot/channel is being used. I6U is shown as being used

I1	I2	I3	I4	I5	I6	I7	I8	I9	I10	I11	I12	I13	I14	
4 I/O : C		VIP : B & F			4 I/O : D		VIP : A					242	242	
φ 1 C1-56 VD1 VD2 C1-60 φ 1	φ 1 C11-16 VD29 VD30 C11-20 φ 1	φ 2 C1-39 VD9 VD10 C1-43 φ 2	φ 2 C1-63 VD11 VD12 C1-76 φ 2	φ 2 C1-47 VD13 VD31 C11-10 φ 2	φ 3 C1-58 VD3 VD4 C1-62 φ 3	φ 3 C11-18 VD32 VD33 C11-22 φ 3	φ 4 C1-41 VD14 VD15 C1-45 φ 4	φ 4 C1-65 VD16 VD17 C1-78 φ 4	φ 4 C1-49 VD18 VD34 C11-12 φ 4	SPARE C11-23	SPARE C11-24	2 PED C1-67	6 PED C1-68	
J1	J2	J3	J4	J5	J6	J7	J8	J9	J10	J11	J12	J13	J14	
4 I/O : F		VIP : C & E			2 I/O : C	4 I/O : A		VIP : D					752	752
φ 5 C1-55 VD5 VD6 C1-59 φ 5	φ 5 C11-15 VD35 VD36 C11-19 φ 5	φ 6 C1-40 VD19 VD20 C1-44 φ 6	φ 6 C1-64 VD21 VD22 C1-77 φ 6	φ 6 C1-48 VD23 VD24 C11-11 φ 6	φ 7 C1-57 VD7 VD8 C1-61 φ 7	φ 7 C11-17 VD38 VD39 C11-21 φ 7	φ 8 C1-42 VD24 VD25 C1-46 φ 8	φ 8 C1-66 VD26 VD27 C1-79 φ 8	φ 8 C1-50 VD28 VD40 C11-13 φ 8	SPARE C1-54	PCOI C1-51	EVA C1-71	EVB C1-72	

INLET FILE I & J (FRONT VIEW)  
(NOT TO SCALE)

Equipment goes in the first row below the slot location. The 2 I/O for camera C spans one slot

Signal designer will import entire input file from excel (signal timer configures the excel file)

The default phase will be shown here – make sure to modify this if the default phase is not being used (e.g., slot J10U will be reprogrammed to phase 7, not phase 8). Note: The maxtime number and the C1 pin number NEVER change.

Equipment used in the detector input location is listed below. For equipment that has more than one model (such as radar equipment) contact state traffic signal engineer, region signal timer or TSSU to determine correct equipment to show in the input file.

- 112 = Radar equipment
- 114 = Radar equipment
- EDGE = Radar equipment
- 222 = Loop detector amplifier
- VIP3D.1: Video image processor
- VIP3D.2: Video image processor
- VIEWCOM: video equipment
- 4 I/O = 4 channel input/output module for video camera
- 2 I/O = 2 channel input/output module for video camera

## 20.6.2 AC Isolator Location (Signal Timer Responsibility – Use Excel File)

This is located in slot J12 (J12U is for the PCOI input and J12L is for the VCOI input). This location is used for railroad preemption. The equipment module number is 255 (NOTE: a 252 is used in 332 cabinets). The example shown in Figure 20-6 below shows where you fill in the equipment.

Figure 20-6 | 332 Cabinet – AC Isolator Equipment

Equipment goes in the first row below the slot location. The AC isolator for a 332S cabinet is 255

11	12	13	14	15	16	17	18	19	110	111	112	113	114
4 I/O :C		VIP :B & F			4 I/O :D			VIP :A				241	242
<input checked="" type="checkbox"/>		<input checked="" type="checkbox"/>	<input checked="" type="checkbox"/>		<input checked="" type="checkbox"/>		<input checked="" type="checkbox"/>	<input checked="" type="checkbox"/>				<input checked="" type="checkbox"/>	<input checked="" type="checkbox"/>
φ 1 C1-56 VD1 VD2 C1-60 φ 1	φ 1 C11-16 VD29 VD30 C11-20 φ 1	φ 2 C1-39 VD9 VD10 C1-43 φ 2	φ 2 C1-63 VD11 VD12 C1-76 φ 2	φ 2 C1-47 VD13 VD31 C11-10 φ 2	φ 3 C1-58 VD3 VD4 C1-62 φ 3	φ 3 C11-18 VD32 VD33 C11-22 φ 3	φ 4 C1-41 VD14 VD15 C1-45 φ 4	φ 4 C1-65 VD16 VD17 C1-78 φ 4	φ 4 C1-49 VD18 VD34 C11-12 φ 4	SPARE C11-23 ---	SPARE C11-24 ---	2 PED C1-67 ---	6 PED C1-68 ---
J1	J2	J3	J4	J5	J6	J7	J8	J9	J10	J11	J12	J13	J14
4 I/O :F		VIP :C & E		2I/O:C	4 I/O :A		VIP :D				255	752	752
<input checked="" type="checkbox"/>		<input checked="" type="checkbox"/>	<input checked="" type="checkbox"/>	<input checked="" type="checkbox"/>	<input checked="" type="checkbox"/>		<input checked="" type="checkbox"/>	<input checked="" type="checkbox"/>			<input checked="" type="checkbox"/>	<input checked="" type="checkbox"/>	<input checked="" type="checkbox"/>
φ 5 C1-55 VD5 VD6 C1-59 φ 5	φ 5 C11-15 VD35 VD36 C11-19 φ 5	φ 6 C1-40 VD19 VD20 C1-44 φ 6	φ 6 C1-64 VD21 VD22 C1-77 φ 6	φ 6 C1-48 VD23 VD37 C11-11 φ 6	φ 7 C1-57 VD7 VD8 C1-61 φ 7	φ 7 C11-17 VD38 VD39 C11-21 φ 7	φ 8 C1-42 VD24 VD25 C1-46 φ 8	φ 8 C1-66 VD26 VD27 C1-79 φ 8	φ 8 C1-50 VD28 VD40 C11-13 φ 8	SPARE C1-54 ---	PCOI C1-51 ---	EVA C1-71 ---	EVB C1-72 ---
											<input checked="" type="checkbox"/>	<input checked="" type="checkbox"/>	<input checked="" type="checkbox"/>
											GPS C1-75 VCOI	4 PED C1-52 EVC	8 PED C1-74 EVD

INPUT FILE I & J (FRONT VIEW)

(NOT TO SCALE)

Signal designer will import entire input file from excel (signal timer configures the excel file)

Check mark the box if the slot/channel is being used. Both the PCOI and VCOI inputs are being used

## 20.6.3 DC Isolator Location (Signal Timer Responsibility – Use Excel File)

This is located in slots I13 and I14 and is used for pushbutton detection. The standard phasing is shown below in Figure 20-7. The equipment module number is 242.

Figure 20-7 | 332 Cabinet – DC Isolator Equipment

Equipment goes in the first row below the slot location. The DC isolator equipment number is 242

I1	I2	I3	I4	I5	I6	I7	I8	I9	I10	I11	I12	I13	I14
4 I/O :C		VIP :B & F			4 I/O :D			VIP :A				242	242
φ 1 C1-56 VD1 VD2 C1-60 φ 1	φ 1 C11-16 VD29 VD30 C11-20 φ 1	φ 2 C1-39 VD9 VD10 C1-43 φ 2	φ 2 C1-63 VD11 VD12 C1-76 φ 2	φ 2 C1-47 VD13 VD31 C11-10 φ 2	φ 3 C1-58 VD3 VD4 C1-62 φ 3	φ 3 C11-18 VD32 VD33 C11-22 φ 3	φ 4 C1-41 VD14 VD15 C1-45 φ 4	φ 4 C1-65 VD16 VD17 C1-78 φ 4	φ 4 C1-49 VD18 VD34 C11-12 φ 4	SPARE C11-23	SPARE C11-24	2 PED C1-67	6 PED C1-68
J1	J2	J3	J4	J5	J6	J7	J8	J9	J10	J11	J12	J13	J14
4 I/O :F		VIP :C & E			2 I/O :C	4 I/O :A		VIP :D			255	751	752
φ 5 C1-55 VD5 VD6 C1-59 φ 5	φ 5 C11-15 VD35 VD36 C11-19 φ 5	φ 6 C1-40 VD19 VD20 C1-44 φ 6	φ 6 C1-64 VD21 VD22 C1-77 φ 6	φ 6 C1-48 VD23 VD37 C11-11 φ 6	φ 7 C1-57 VD7 VD8 C1-61 φ 7	φ 7 C11-17 VD38 VD39 C11-21 φ 7	φ 8 C1-42 VD24 VD25 C1-46 φ 8	φ 8 C1-66 VD26 VD27 C1-79 φ 8	φ 8 C1-50 VD28 VD40 C11-13 φ 8	SPARE C1-54	PC01 C1-51	φ 8 C1-71	EVB C1-72
												4 PED	8 PED

**INPUT FILE I & J (FRONT VIEW)**  
(NOT TO SCALE)

Signal designer will import entire input file from excel (signal timer configures the excel file)

Check mark the box if the slot/channel is being used. All 4 ped phases are used in this example.

## 20.6.4 Pedestrian Detector Termination

Figure 20-8 shows the terminal block where the pedestrian detectors are wired. Fill in the phase for the pedestrian pushbuttons being used.

Figure 20-8 | 332 Cabinet – Pedestrian Detector Termination

Fill the box with the phase. Standard phases are shown here. Leave blank if ped phase is not used.

**\*\* NOTE**

USE PED P.B. COMM. BUS FOR MORE THAN 2 PED P.B. COMM. WIRES. (SEE PAGE 1 SIDE VIEW REAR LEFT FOR

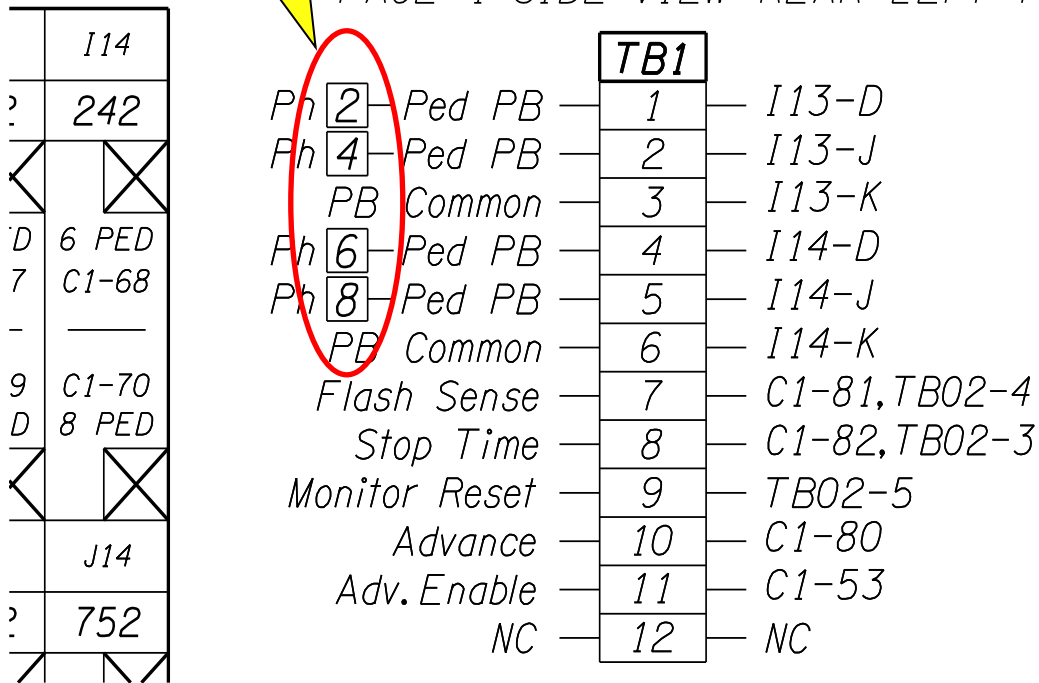

## 20.6.5 Fire Preemption Detectors (Signal Timer Responsibility – Use Excel File)

Fire preemption detector equipment is located in slots J13 and J14 and provides the input for fire preemption. The equipment modules for fire preemption detectors are 752 (Opticom phase selector) and 2140 (Tomar Stobecom II O.S.P.). See Figure 20-9.

Figure 20-9 | 332 Cabinet – Fire Preemption Detector Equipment

Equipment goes in the first row below the slot location.  
The equipment number is either 752 or 2140

11	12	13	14	15	16	17	18	19	20	21	22	113	114	
4 I/O :C		VIP :B & F				4 I/O :D				VIP :A			242	242
<input checked="" type="checkbox"/>	<input type="checkbox"/>	<input checked="" type="checkbox"/>	<input checked="" type="checkbox"/>	<input type="checkbox"/>	<input checked="" type="checkbox"/>	<input type="checkbox"/>	<input checked="" type="checkbox"/>	<input checked="" type="checkbox"/>	<input type="checkbox"/>	<input type="checkbox"/>	<input type="checkbox"/>	<input checked="" type="checkbox"/>	<input checked="" type="checkbox"/>	
φ 1 C1-56 VD1 VD2 C1-60 φ 1	φ 1 C11-16 VD29 VD30 C11-20 φ 1	φ 2 C1-39 VD9 VD10 C1-43 φ 2	φ 2 C1-63 VD11 VD12 C1-76 φ 2	φ 2 C1-47 VD13 VD31 C11-10 φ 2	φ 3 C1-58 VD3 VD4 C1-62 φ 3	φ 3 C11-18 VD32 VD33 C11-22 φ 3	φ 4 C1-41 VD14 VD15 C1-45 φ 4	φ 4 C1-65 VD16 VD17 C1-78 φ 4	φ 4 C1-49 VD18 VD34 C11-12 φ 4	SPARE C11-23 SPARE	SPARE C11-24 SPARE	2 PED C1-67 4 PED C1-69	6 PED C1-68 8 PED C1-70	
J1	J2	J3	J4	J5	J6	J7	J8	J9	J10	J11	J12	J13	J14	
4 I/O :F		VIP :C & E		2I/O:C	4 I/O :A		VIP :D				255	752	752	
<input checked="" type="checkbox"/>	<input type="checkbox"/>	<input checked="" type="checkbox"/>	<input checked="" type="checkbox"/>	<input checked="" type="checkbox"/>	<input checked="" type="checkbox"/>	<input type="checkbox"/>	<input checked="" type="checkbox"/>	<input checked="" type="checkbox"/>	<input type="checkbox"/>	<input type="checkbox"/>	<input checked="" type="checkbox"/>	<input checked="" type="checkbox"/>	<input checked="" type="checkbox"/>	
φ 5 C1-55 VD5 VD6 C1-59 φ 5	φ 5 C11-15 VD35 VD36 C11-19 φ 5	φ 6 C1-40 VD19 VD20 C1-44 φ 6	φ 6 C1-64 VD21 VD22 C1-77 φ 6	φ 6 C1-48 VD23 VD37 C11-11 φ 6	φ 7 C1-57 VD7 VD8 C1-61 φ 7	φ 7 C11-17 VD38 VD39 C11-21 φ 7	φ 8 C1-42 VD24 VD25 C1-46 φ 8	φ 8 C1-66 VD26 VD27 C1-79 φ 8	φ 8 C1-50 VD28 VD40 C11-13 φ 8	SPARE C1-54 GPS	PCOI C1-51 VCOI	EVA C1-71 EVC	EVB C1-72 EVD	

INPUT FILE I & J (FRONT VIEW)  
(NOT TO SCALE)

Signal designer will import entire input file from excel (signal timer configures the excel file)

Check mark the box if the slot/channel is being used. All 4 EV phases are used in this example.

## 20.6.6 Fire Preemption Detection Termination

Figure 20-10 shows the terminal block where the fire preemption is wired. Mark the check box if the EV channel is being used.

Figure 20-10 | 332 Cabinet – Fire Preemption Detector Termination

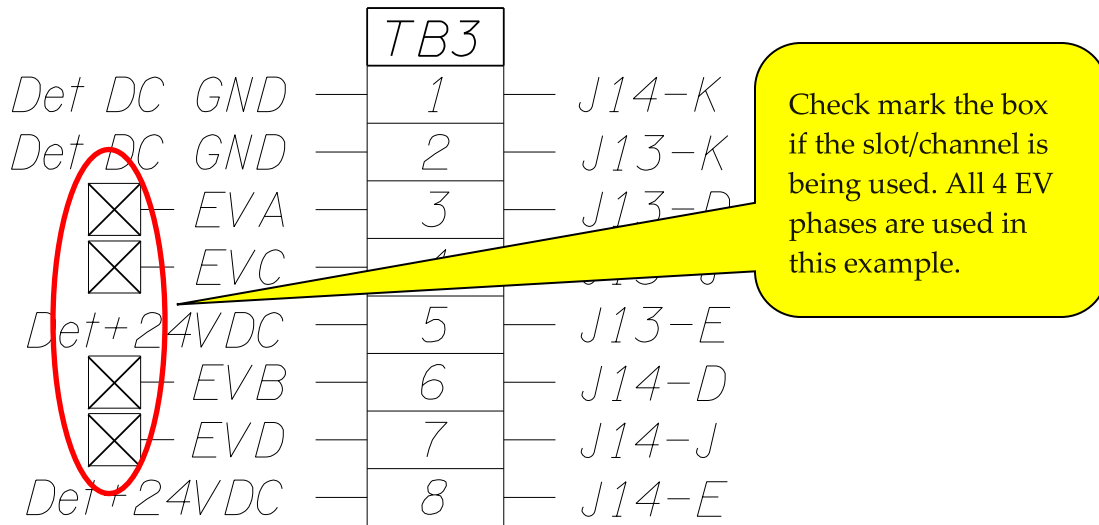



## 20.6.7 Detector Input Termination

Vehicle detection is wired to terminal block TB5 and TB6. In a 332s cabinet, this location should remain blank when using video, radar or SDLC as shown in Figure 20-11 below (display the proper models as per the microstation base file instructions). Loop detection is the only type of detection that requires entering info and is shown in Figure 20-12.

Figure 20-11 | 332 Cabinet – Detector Input Termination for Video, Radar, or SDLC

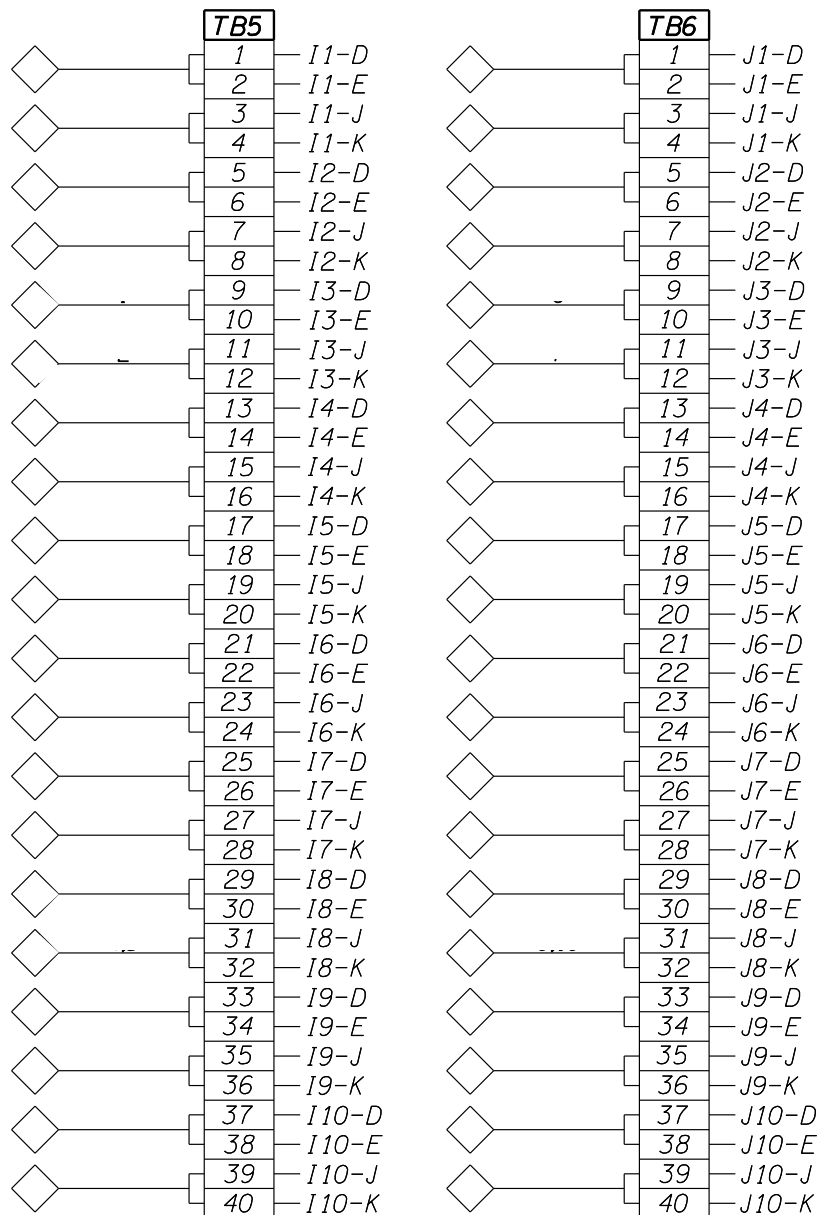

Leave TB5 and TB6 Blank if using video, radar or SDLC

Figure 20-12 | 332 Cabinet – Detector Input Termination for Loops

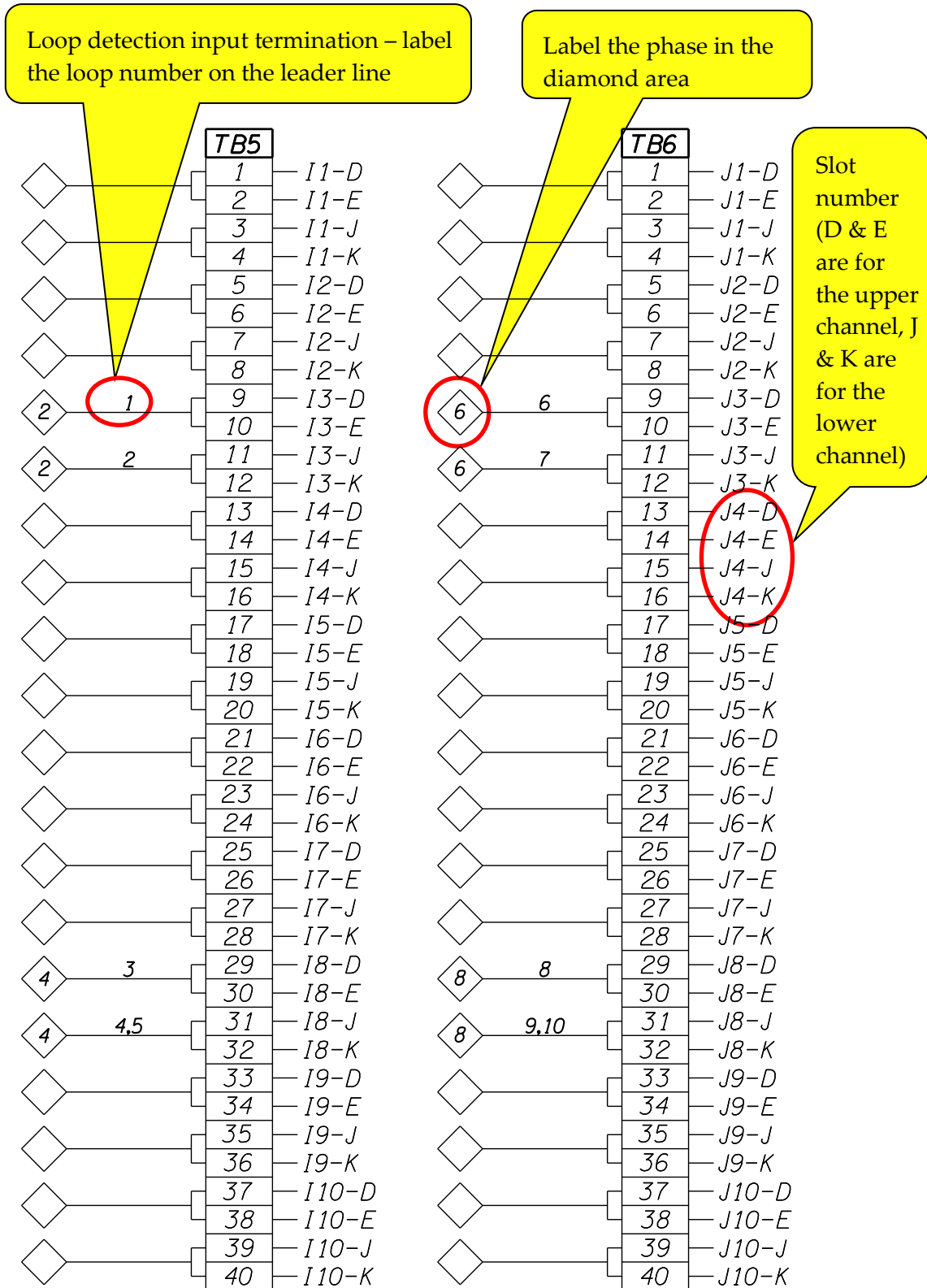

## 20.6.8 Additional Information about the Input File

### 332 Cabinet Without a C11 Connector

28 vehicle inputs using 9 slots and 2 input files that is wired to accommodate:

- 2 vehicle detection inputs to the controller for each odd numbered phase
- 5 vehicle detection inputs to the controller for each even numbered phase
- 4 pedestrian detection inputs (Slot I12 and I13)
- 4 emergency preemption inputs (Slot J12 and J13)
- 2 railroad preemption inputs (Slot J11: indirect via 4 C1 pins using a 252 AC Isolator)
- 0 spares

Each input file slot has (2) channels associated with it, the upper and the lower. The slot may have one or two controller inputs wired to it. Slots 1, 4, 5, and 8 have one controller input. Slots 2, 3, 6, 7, 9, 12, and 13 have two controller inputs. Slot 10, I11 and 14 have no inputs and are not used (e.g., no C1 pin).

If a viewcom module is used, it will go in slot I10 and I11.

### 332S Cabinet With a C11 Connector

40 vehicle inputs using 10 slots and 2 input files that is wired to accommodate:

- 4 vehicle detection inputs to the controller for each odd numbered phase
- 6 vehicle detection inputs to the controller for each even numbered phase
- 4 pedestrian detection inputs (Slot I13 and I14)
- 4 emergency preemption inputs (Slot J13 and J14)
- 2 railroad preemption inputs (Slot J12: direct via inverting a 255 AC isolator)
- 1 GPS (J11L)
- 5 spares (Slot I11U, I11L, J11U, J12U, and J12L)

Each input file slot has (2) channels associated with it, the upper and the lower. All slots have two controller inputs wired to it (assigned to the C1 or C11 connector).

If a viewcom module is used, it will go in slot I11 and I12. The C11 pins need to be disconnected for the viewcom module to function.

# 20.7 332S Cabinet Print (Page 3 – Output File)

Page 3 of the 332S cabinet print shows the output file and conflict monitor. This sheet requires filling in the information for all the output equipment used. The basic output equipment (e.g., load switches, flash transfer relays, flash plugs, etc.) that needs to be filled in is shown in Figure 20-13. Each bubble note in Figure 20-13 is numbered and described in more detail in the next sections. **Important additional information about the output file is in section 20.7.5.**

Figure 20-13 | 332S Cabinet Print (Page 3 – Output File)

**1.) Main output file (front view) - check mark boxes that are used, label phase and flash plug color**

**2.) Main output file (back view) - label phases**

**3.) Conflict monitor diode card**

**4.) Auxiliary output file (front and back) – If used, mark and label the same as main output file.**

**Verify this information matches the conflict monitor diode card channels actually used. If different, follow the DGN instructions on the website as per section 20.4**

For reference, Figure 20-14 shows the actual front view of the output file in a 332 cabinet (which is very similar to the 332S).

Figure 20-14 | 332 Cabinet – Output File (Front View) Actual View

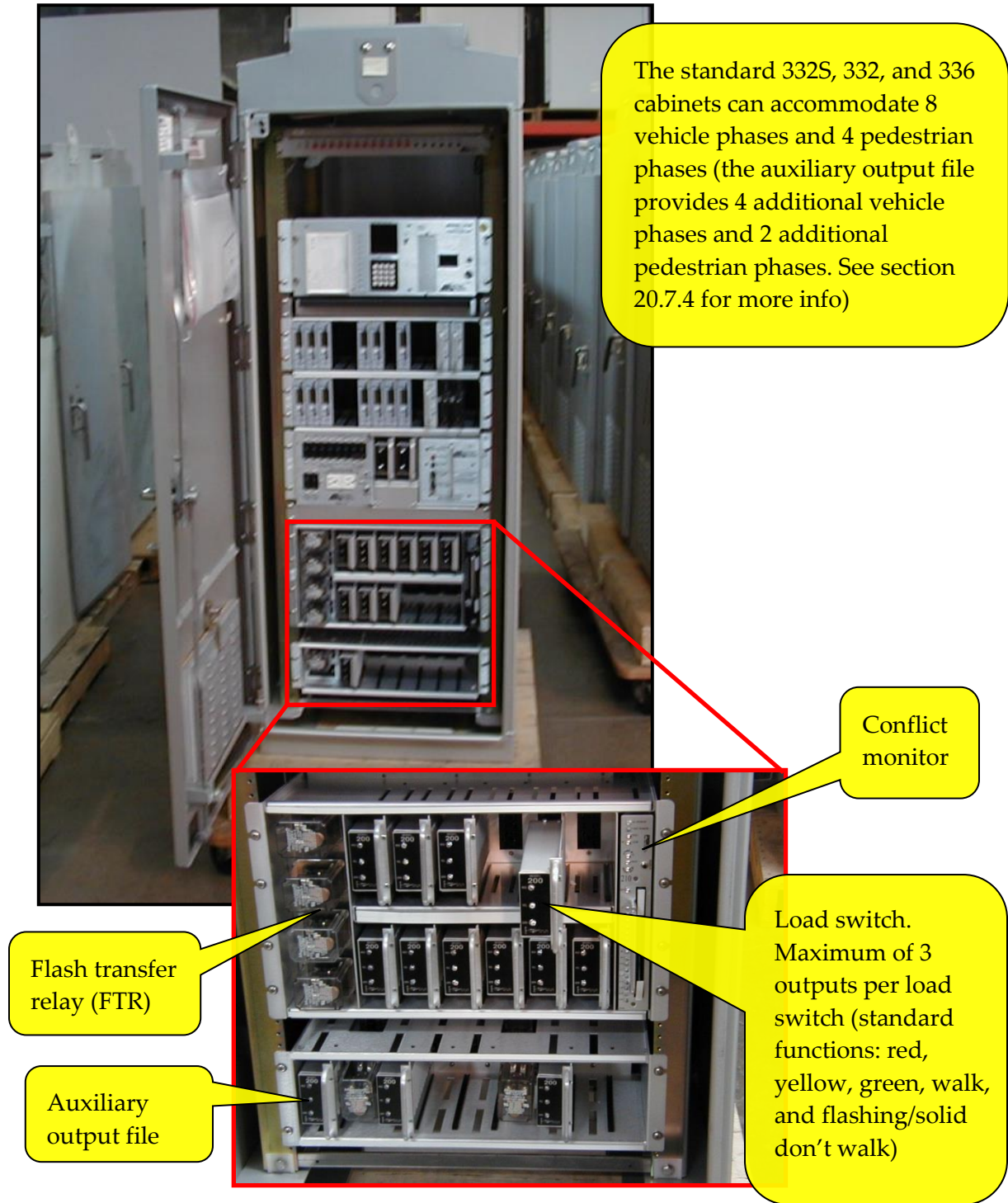

## 20.7.1 Main Output File (Front View):

The main output file (front view) shows the load switches that are used to power the field indications (vehicle signals: red, yellow, green and pedestrian signals: walk, flashing don't walk). Other types of powered indications, such as PTR signs or advance flashing beacons may be wired to a load switch. Dummy phases do not have a field output (not wired to any load switches) and only exist in controller to allow for proper phase rotation. Do not show dummy phases in the output file. Each load switch that corresponds to a vehicle phase will have a flash plug (red, yellow, or white).

The flash transfer relays (FTR) are used to switch power from the load switches to the flasher units during cabinet flash. All four flash transfer relays should be included.

The conflict monitor checks the green indications, flashing yellow arrow and walk indications (and a few other items, such as voltage, connection to the controller, etc.) and causes the signal to go into cabinet flash if any conflicting indications come up together.

See Figure 20-15 for an example.

Figure 20-15 | 332 Cabinet – Main Output File (Front View)

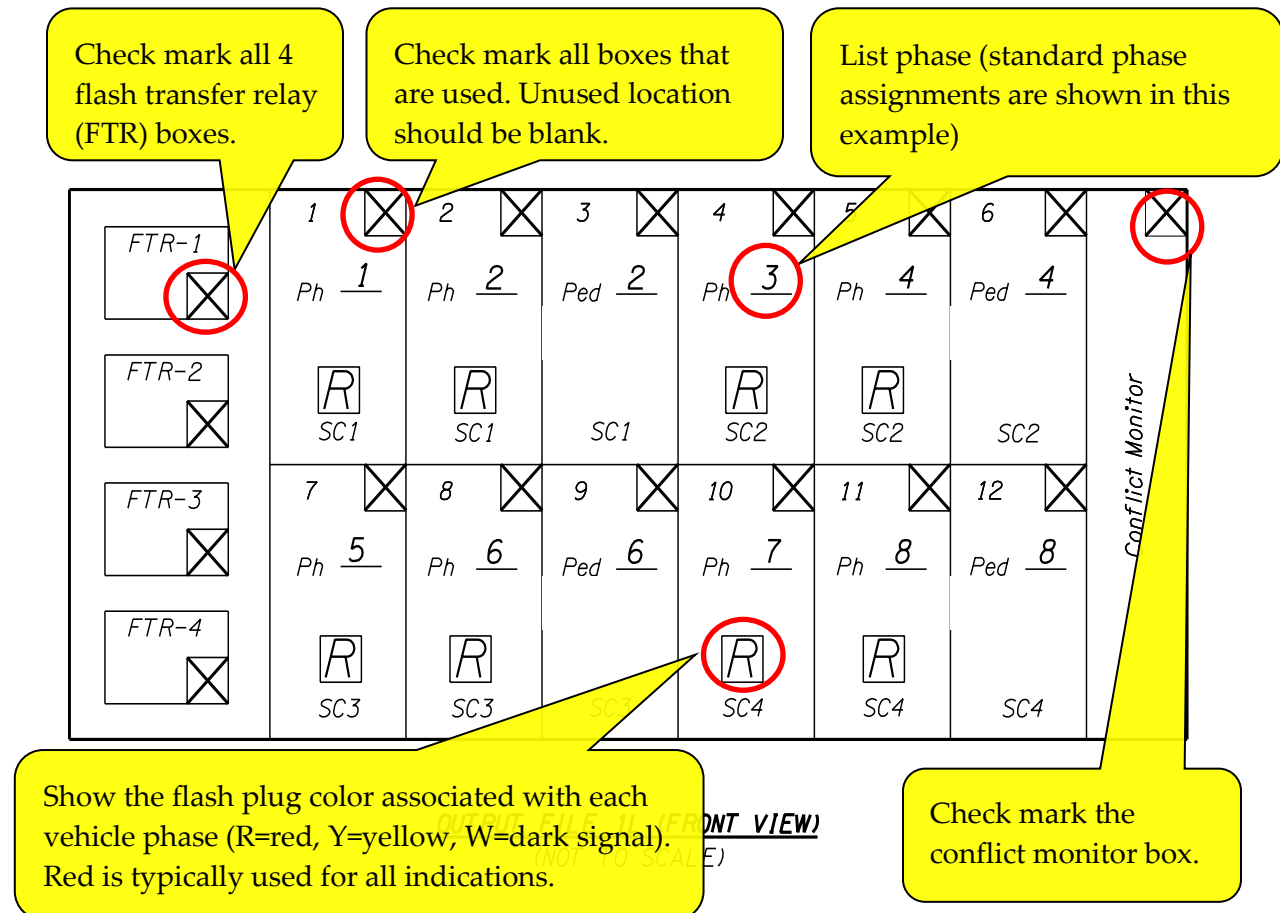

## 20.7.2 Main Output File (Back View)

Figure 20-16 shows the terminal blocks for the output file. Fill in the phases being used.

Figure 20-16 | 332 Cabinet – Main Output File (Back View)

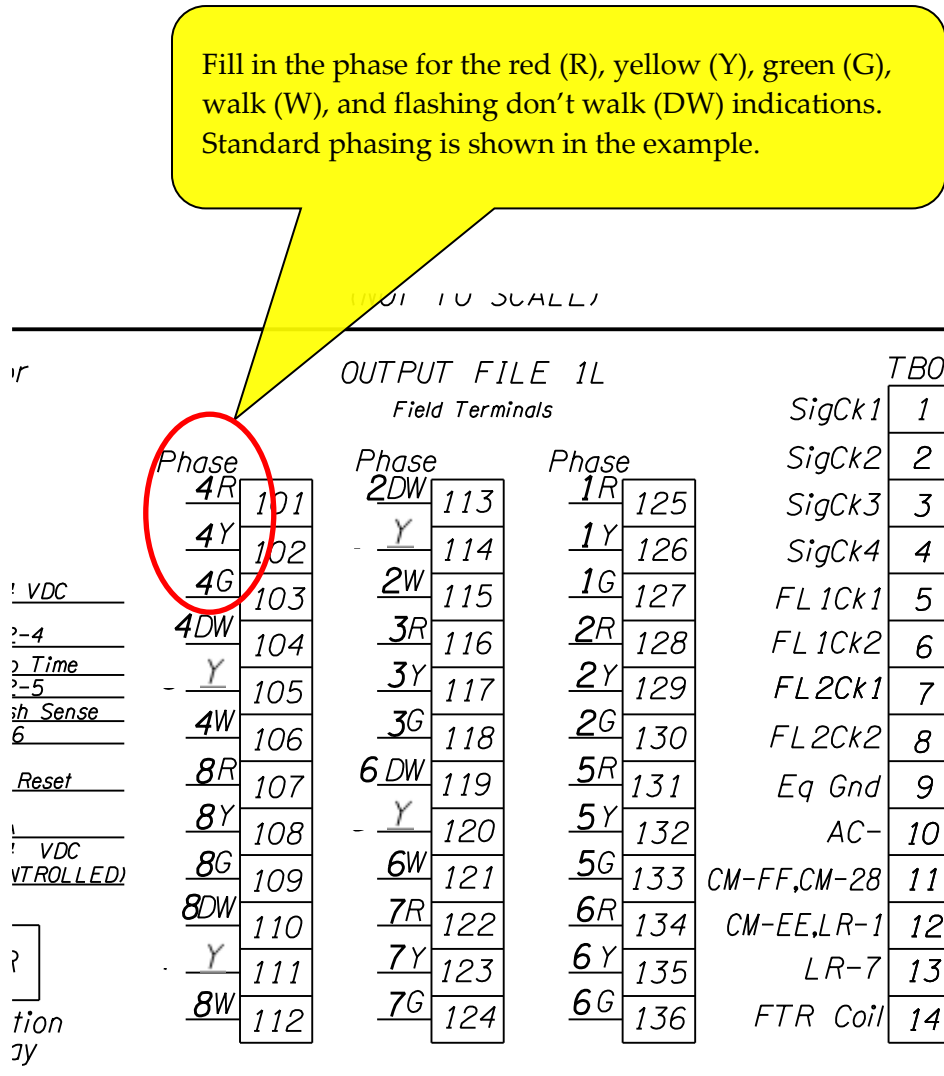

### OUTPUT FILE 1L (REAR VIEW)

(NOT TO SCALE)

## 20.7.3 Conflict Monitor Diode Card

The signal designer will complete the conflict monitor diode card. It will be reviewed and approved by TSSU and/or the traffic engineering section. By default, the conflict monitor is configured such that ALL phases are conflicting (all diodes are intact). The diodes for non-

Traffic-Signal Design Manual – Cabinet Prints

conflicting phases will be removed, leaving the diodes for conflicting phases intact. Only the phases that are actually used will determine the monitor configuration (e.g., if phase 3 and 7 are not used, those diodes will remain intact, even though phase 3 and phase 7 are typically non-conflicting phases). See Figure 20-17 for an example.

Figure 20-17 | 332 Cabinet – Conflict Monitor Diode Card

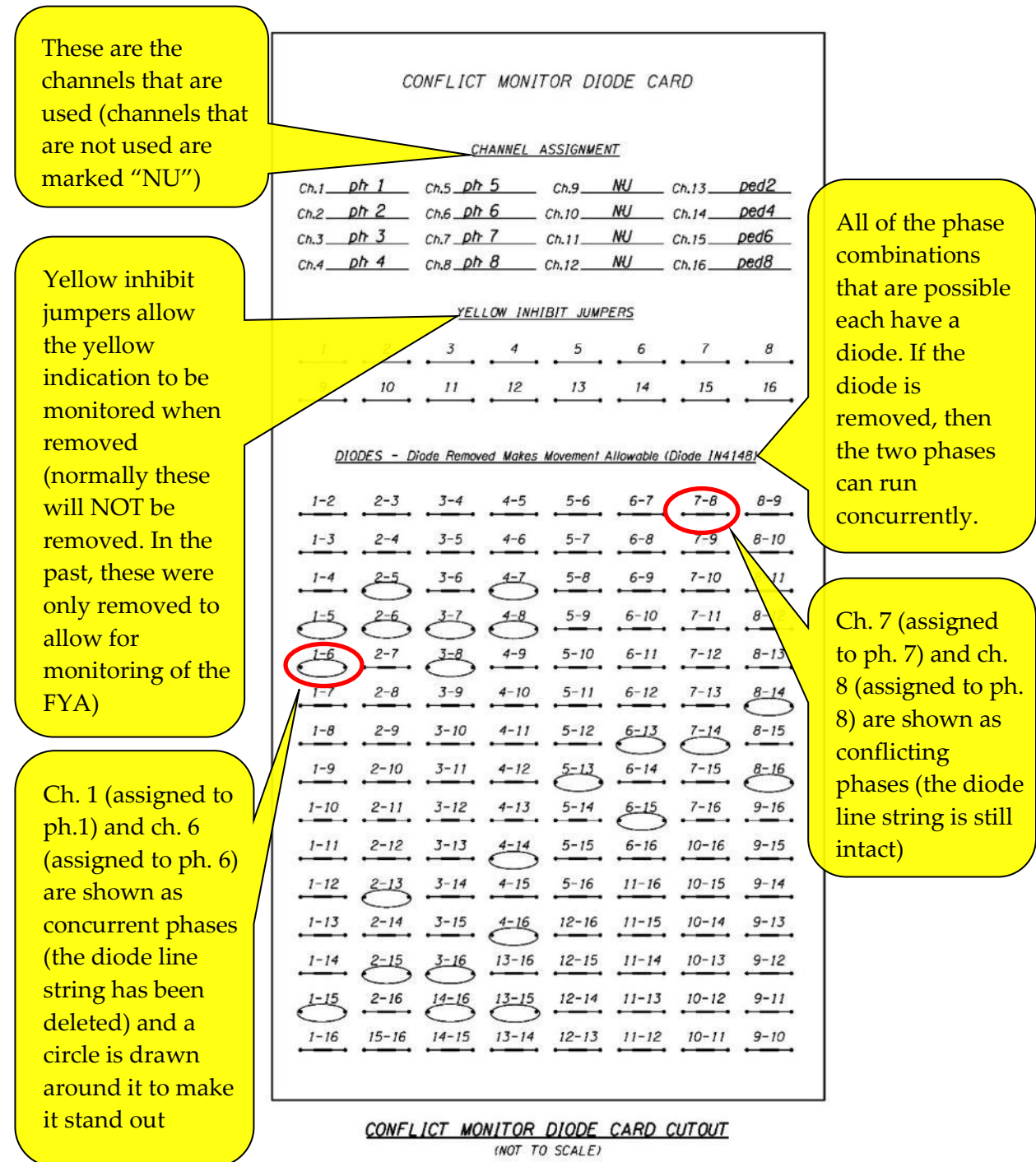



**Outputs That Are Monitored**

All green, walk and flashing yellow arrow outputs for each phase shall be monitored by the conflict monitor. These are critical indications for each phase because they inform the driver or pedestrian when it is OK to enter or precede through the intersection. Monitoring these outputs for conflict ensures that a driver or pedestrian will never be incorrectly informed when it is OK to enter the intersection.

The green and walk outputs are always wired to the conflict monitor by the manufacturer as per the Standard Specification for Microcomputer Signal Controller. See Figure 20-18 with the monitored channels shown in red. **ANY OUTPUT ASSIGNED TO ONE OF THESE LOCATIONS WILL BE MONITORED. Do NOT reassign an output that shouldn't be monitored to one of these locations.**

The yellow indication can be monitored by removing the yellow inhibit jumpers on the diode card (note: this was used in the past for monitoring flashing yellow arrows), but it does NOT operate independently of the green indication on the same load switch. For example, if ped phase 2 yellow is monitored by removing the yellow inhibit jumpers, it will have the exact same conflicts as ped phase 2 walk. This can be advantageous for monitoring the flashing yellow arrow, as the opposing pedestrian phase typically has the same conflicts (e.g., ped phase 2 walk has the same conflicts as ph. 1 flashing yellow arrow), but widespread use of negative ped phasing, overlaps, and type 3LCF signal heads resulted in problems when monitoring the FYA via the yellow indication. Therefore, this method is no longer allowed. See section 20.13.1 for more info.

Figure 20-18 | Monitored Outputs

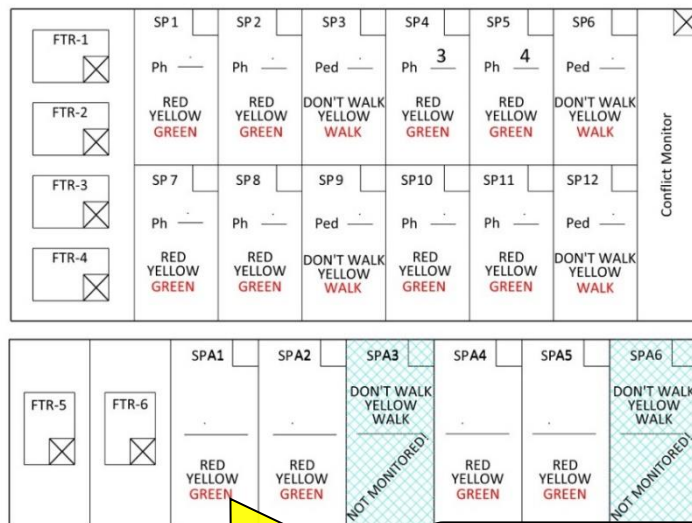

Green & walk outputs are always monitored

Each switch pack location has a load switch with three outputs: For vehicle phases: red, yellow, and green For ped phases: flashing don't walk, yellow, and walk

Not all outputs require conflict monitoring as they are not as critical to eliminating the crash potential associated with being incorrectly informed. For example, the yellow and red outputs for each phase inform the driver or pedestrian that they must stop. If a driver is shown one of these indications erroneously, the action the driver is informed to take (stop) should not result in a crash with a conflicting vehicle that has been informed by a green indication.

Outputs that are NOT monitored include:

- Red outputs
- Yellow outputs
- Flashing don't walk outputs
- PTR sign outputs\*
- Fire signal confirmation indication outputs\* (Note: this refers to legacy installations that have not been updated to the current standard, as these are no longer allowed for new construction. As per chapter 17, the new standard requires tattletale lights which are not assigned to an output and are directly wired to the RED signal indication.)

\*It is important to note that PTR sign output and fire signal confirmation indication outputs always require an output reassignment (as they do not have a standard output location). Do NOT reassign these outputs to a load switch location that is monitored (see Figure 20-18).

The conflict monitor also monitors other critical aspects of the how the traffic signal is functioning (watchdog, voltages, etc.) as per the Standard Specification for Microcomputer Signal Controller. Unlike the diode card, these aspects do NOT require a custom configuration for each intersection.

Rules for Standard Signal Timing Configurations

When using a standard ring and barrier configuration (see Figure 20-19 and chapter 3 for more information on ring and barrier configuration), the following rules apply:

- An active phase is defined as a movement whose green, walk, or flashing yellow arrow intervals are being timed by the controller.
- Only ONE active phase per ring at a time
- A phase can be active with the phase vertically opposite or diagonal from it as long as it exists on the same side of the barrier. These are called compatible phases (e.g., phase 1 and phase 5, phase 1 and phase 6)
- Both rings must cross the barrier at the same time

Figure 20-19 | Standard 8 Phase Ring and Barrier Diagram

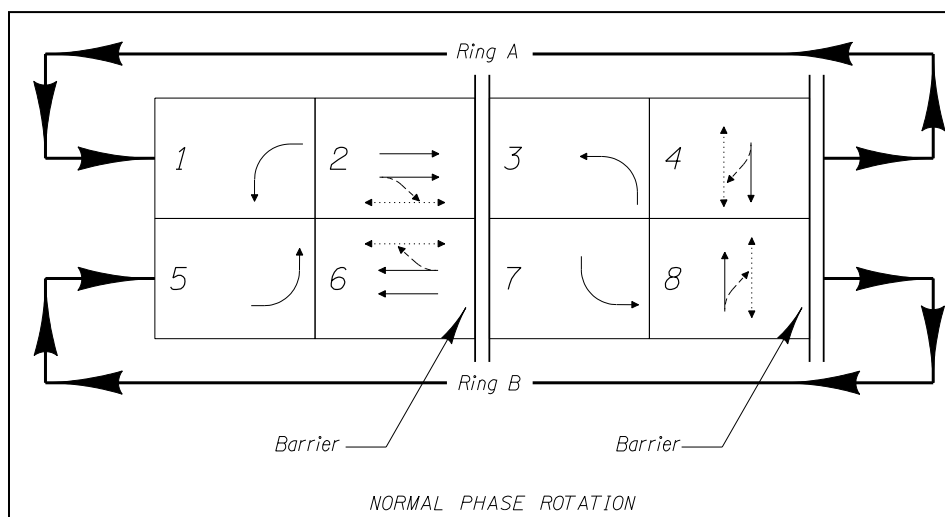

When using overlap phases the following rules apply:

- An overlap phase may be assigned with any phase or number of phases. These are called the parent phase(s).
- An overlap phase will be permitted by every phase compatible with the assigned parent phase. For example, if Figure 20-19 had an OLA = phase 2, then OLA will also be permitted with ped phase 2, phase 5, phase 6, ped phase 6.
- Any phase can have a pedestrian phase assigned to it, limited by the available outputs from the controller.

When using flashing yellow arrow the following rules apply (for additional background information see section 20.13.1):

- The flashing yellow arrow signal head type shall be a type 3LCF
- Phase 1 FYA/YA = Channel 9
  - RED arrow terminated on ph. 1 RED
  - FYA/solid YELLOW arrow terminated on OLA GREEN
  - GREEN arrow terminated on ph. 1 GREEN
- Phase 3 FYA/YA = Channel 10
  - RED arrow terminated on ph. 3 RED
  - FYA/solid YELLOW arrow terminated on OLB GREEN
  - GREEN arrow terminated on ph. 3 GREEN
- Phase 5 FYA/YA = Channel 11
  - RED arrow terminated on ph. 5 RED
  - FYA/solid YELLOW arrow terminated on OLC GREEN
  - GREEN arrow terminated on ph. 5 GREEN
- Phase 7 FYA/YA = Channel 12
  - RED arrow terminated on ph. 7 RED
  - FYA/solid YELLOW arrow terminated on OLD GREEN
  - GREEN arrow terminated on ph. 7 GREEN

Note: Each FYA/YA phase (for a left or right turn) and each overlap phase green indication require termination on a separate overlap green location (OLA through OLD) for proper conflict monitoring. This limits the total number of FYA/YA phases and overlap phases combined at an intersection to four. See section 20.7.5 for more info on the limitations.

See "channel assignments – output reassignment order of priority for FYA/YA phases & overlap phases" in this section for info on properly assigning ch. 9 through ch. 12 when the intersection has a combination of FYA/YA and overlap phases.

**Channel Assignment - Standard**

On a standard model 210 conflict monitor, there are 16 channels that can be monitored. Each active phase (green, walk, or flashing yellow arrow) shall be assigned to a channel on the conflict monitor. The standard channel and phase assignment is shown in Figure 20-20. Switch packs A3 and A6 are NOT wired to the conflict monitor. Each monitored channel is ALWAYS directly wired to the switch pack location as shown in Figure 20-20. For example, channel 1 (regardless of what phase channel 1 is associated with) is ALWAYS wired to switch pack 1. Each channel is associated with the phase shown in Figure 20-20, unless there are output reassignments (done via the signal software).

Figure 20-20 | Standard Channel Assignment

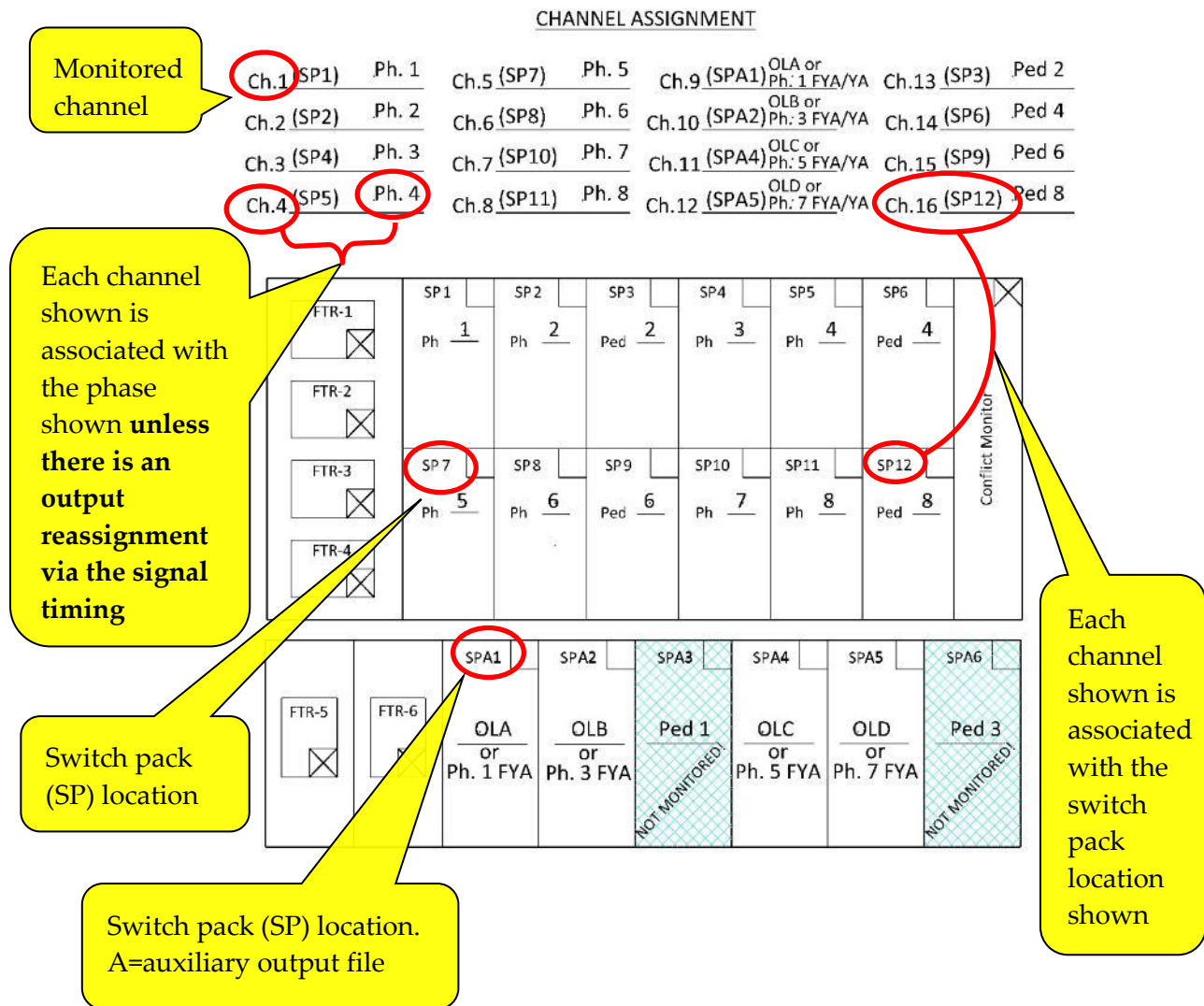

Channel Assignment – Output Reassignments

There are cases where it is necessary to reassign the output because a standard designation does not exist in the output file, such as:

- An odd numbered ped phase
- A ped overlap phase
- A flashing yellow arrow

In the past, output reassignments for vehicle overlap phases were commonly done to avoid installing an auxiliary output file. Auxiliary output files are now installed standard in 332S cabinets, so this practice is no longer required for new installations.

Output reassignments are done via the signal timing software. **Always verify with the signal timer any output reassignments.** Figure 20-21 shows an example where the channel 3 switch pack location SP4 has been reassigned to ped A. Flashing yellow arrows have been reassigned to the unused overlap phase switch packs.

Figure 20-21 | Channel Assignment – Output Reassignments

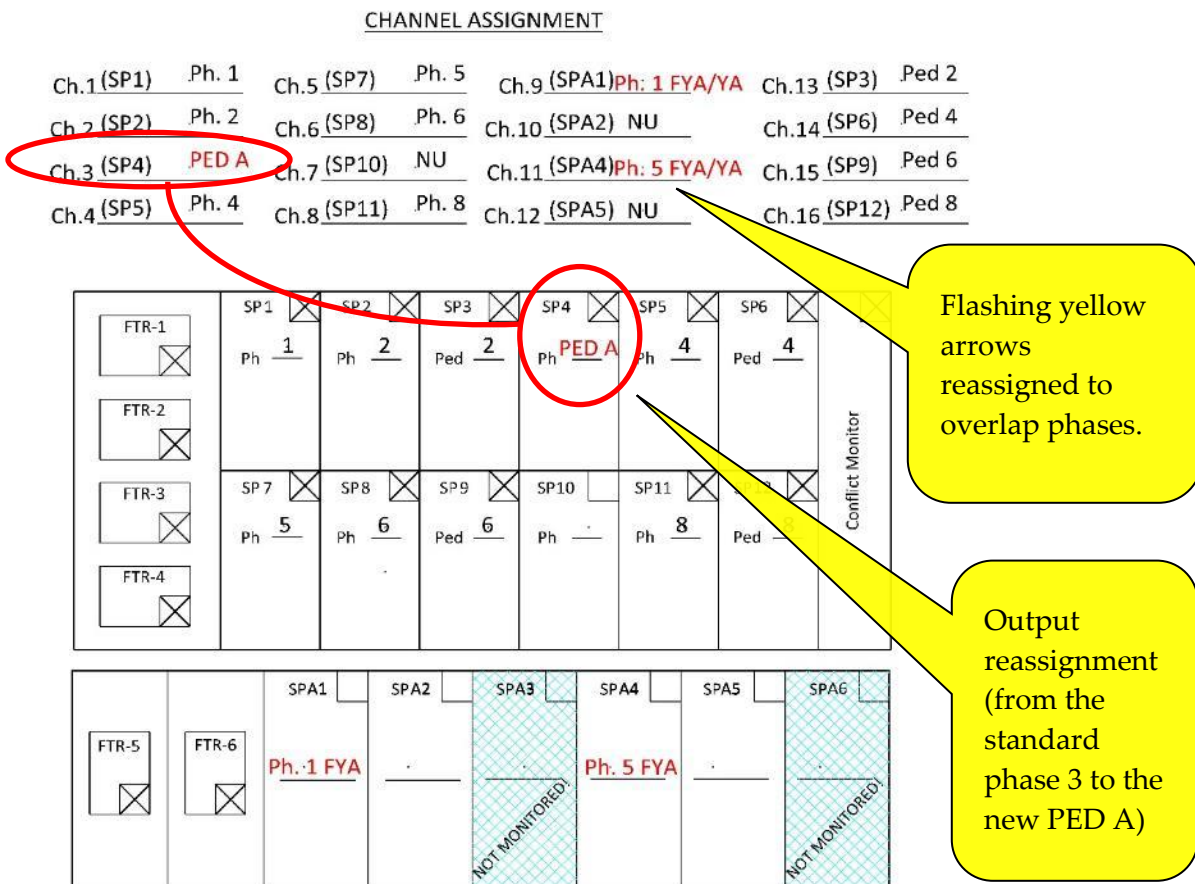

**Channel Assignment – Output Reassignment Order of Priority for FYA/YA phases & Overlap Phases**

If there is a combination of left-turn flashing yellow arrows, right-turn flashing yellow arrows, and overlap phases at the same intersection, use the following order of priority to rearrange the auxiliary outputs (ch. 9 through ch. 12) when the standard switch pack locations for the type 3LCF signal heads, type 3RCF signal heads, and overlap signal heads conflict. See Figure 20-22:

1. Place the type 3LCF signal head outputs first in their standard output locations.
2. Next, place the type 3RCF signal head outputs in their standard output locations if possible. If not possible due to a conflict with a type 3LCF signal head output, place the type 3RCF signal head outputs in the next available unused overlap switch pack locations.
3. Next, place the overlap signal head outputs in the next available unused overlap switch pack locations.

Figure 20-22 | Order of Priority for Standard Placement of Type 3LCF Signal Heads, Type 3RCF Signal Heads, and Overlap Signal Heads in the Auxiliary Output File

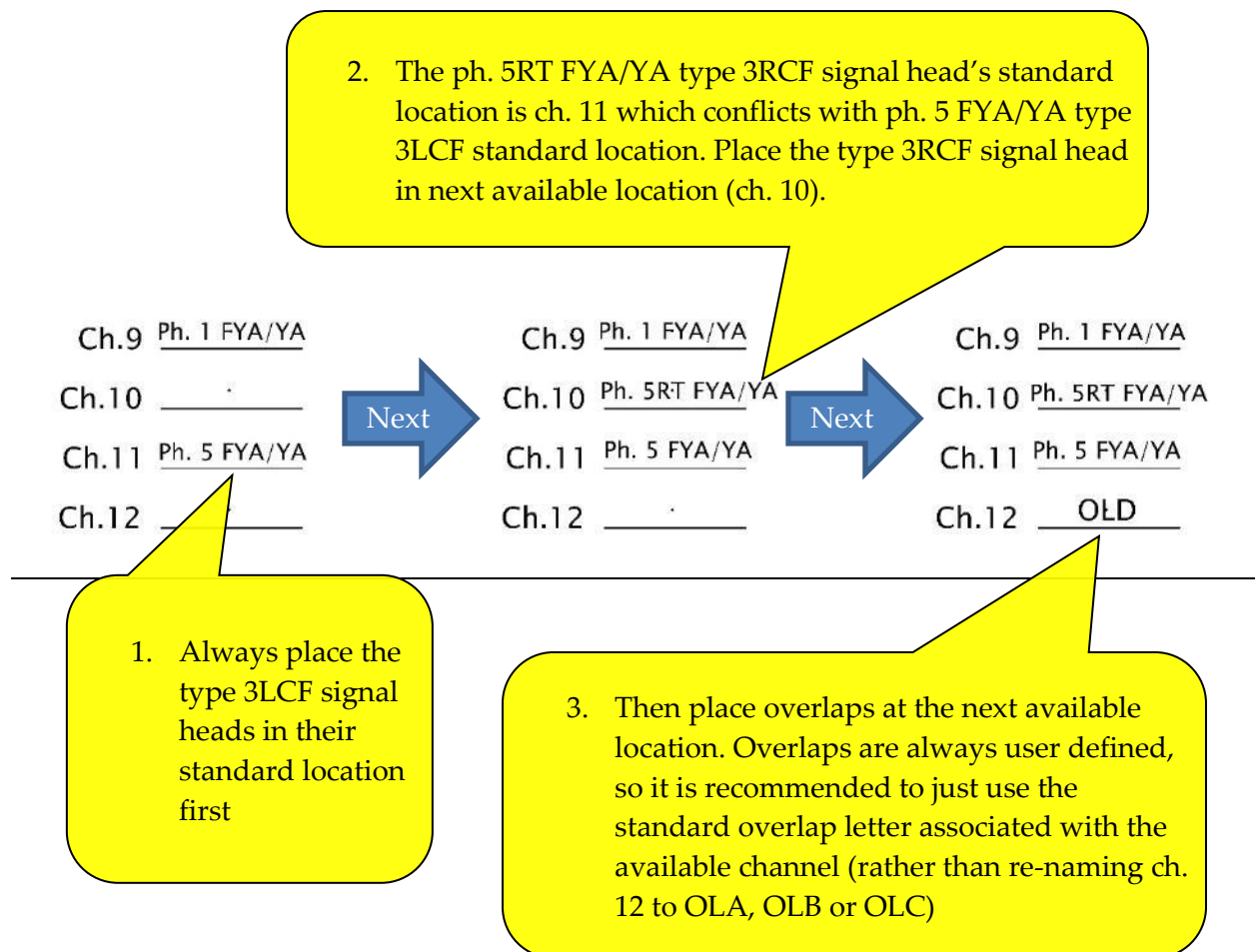

Determining Compatible Phases for the Diode Card

Collect all information about the intersection that will be needed in order to determine the compatible phases, such as:

- Vehicle phases in use
- Pedestrian phases in use
- Parent phase assignments of overlaps
- Exclusive phase assignments
- Output reassignments from signal timing
- Load switches in use (note: dummy phases are not wired to load switches and therefore are not listed in the conflict monitor channel assignment)
- Existing cabinets: verify cabinet is wired as per standard with TSSU

Step 1: Assign phases to the channels. If a channel is not used, write “NU” next to it.

CHANNEL ASSIGNMENT							
Ch.1 (SP1)	Ph. 1	Ch.5 (SP7)	Ph. 5	Ch.9 (SPA1)	OLA	Ch.13 (SP3)	Ped 2
Ch.2 (SP2)	Ph. 2	Ch.6 (SP8)	Ph. 6	Ch.10 (SPA2)	NU	Ch.14 (SP6)	Ped 4
Ch.3 (SP4)	Ph. 3	Ch.7 (SP10)	Ph. 7	Ch.11 (SPA4)	NU	Ch.15 (SP9)	Ped 6
Ch.4 (SP5)	Ph. 4	Ch.8 (SP11)	Ph. 8	Ch.12 (SPA5)	NU	Ch.16 (SP12)	NU

Based on intersection info, assign each phase used to a monitor channel

Step 2: Write the monitor channels in the ring and barrier diagram for (pay close attention to outputs that have been reassigned):

- Each vehicle phase used.
- Each pedestrian phase used.
- Each parent phase assigned to an overlap. For example, if OLA = ph. 1 and ph. 8, and OLA is assigned to channel 9, then write 9 in the phase 1 box and 9 in the phase 8 box of the ring and barrier diagram.

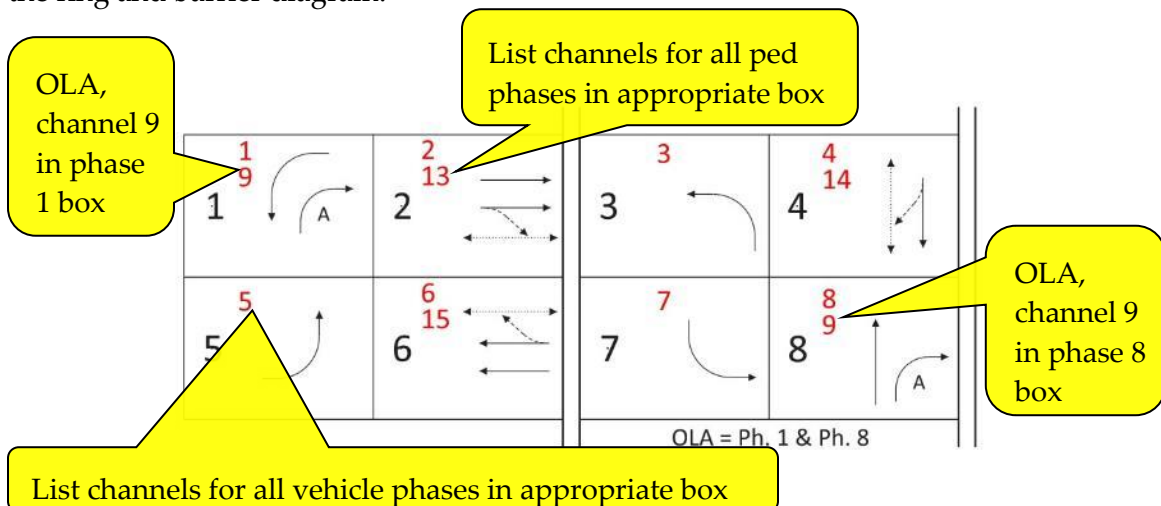



Step 3: Determine the compatible phases (diode pairs that need to be removed). The following procedure will ensure that all correct diodes are removed. There are likely to be a few duplicate diode pairs for phases with overlaps. This is OK, since a diode can only be removed once.

STEP 3A: LIST ALL DIODE PAIRS FOR EACH MONITOR CHANNEL IN THE SAME BOX

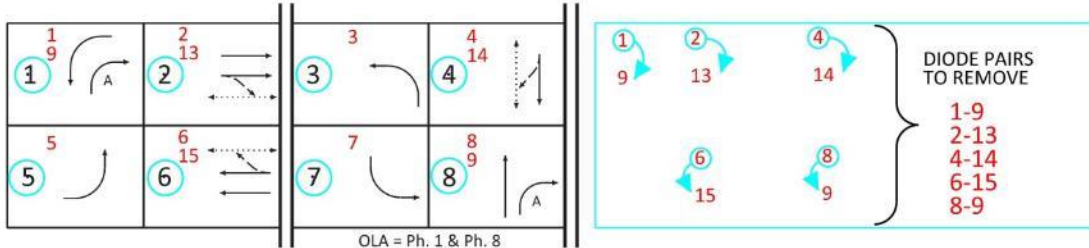

STEP 3B: START IN UPPER LEFT BOX OF THE DIAGRAM. LIST ALL DIODE PAIRS FOR EACH MONITOR CHANNEL THAT IS VERTICALLY OR DIAGONALLY OPPOSITE THE BOX (EXCEPT ANY EXCLUSIVE PHASES).

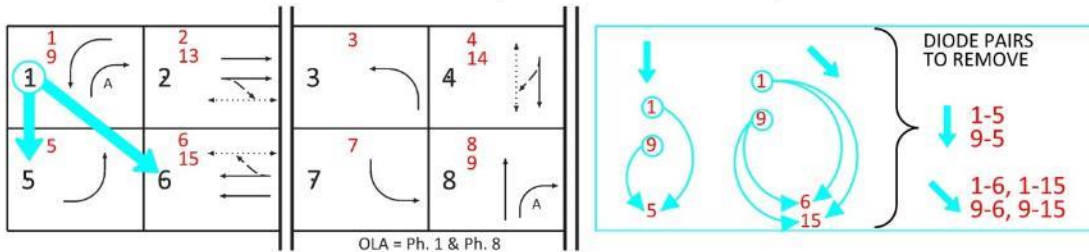

STEP 3C: REPEAT STEP 3B FOR EACH BOX ON THE UPPER ROW OF THE DIAGRAM.

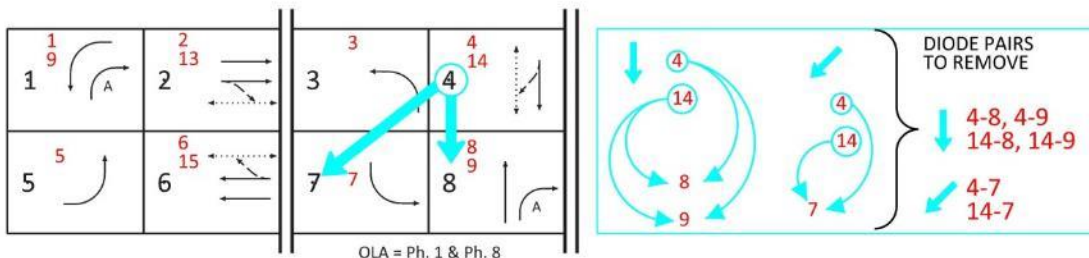
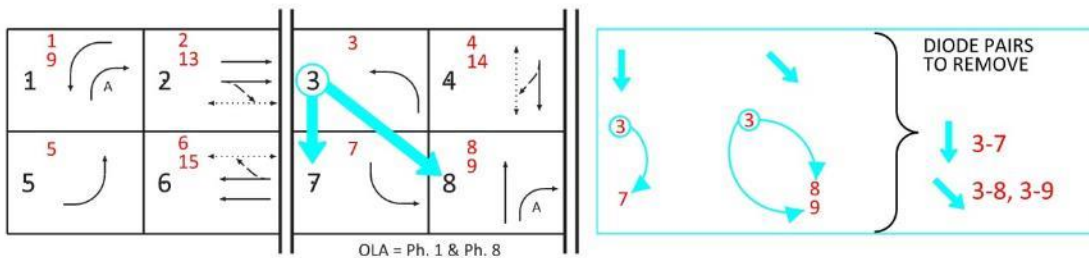
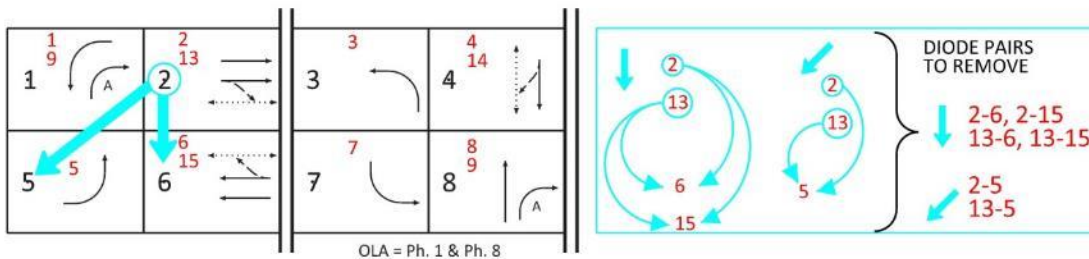

### Traffic-Signal Design Manual – Cabinet Prints

When an intersection has a type 3LCF signal head for PPLT AND has any overlap phases, the conflict monitor diode configuration shall be determined by using the standard ring and barrier diagram method (shown on the previous page) **PLUS a separate ring and barrier diagram showing only the overlap green movements (vehicle and pedestrian) and the solid yellow left turn arrow of the type 3LCF signal head.** See Figure 20-23.

Figure 20-23 | Determining Compatible Phases – FYA (Type 3LCF Signal Head) and Overlap Phases

**CHANNEL ASSIGNMENT**

Ch.1 (SP1) Ph. 1	Ch.5 (SP7) NU	Ch.9 (SPA1) Ph. 1 FYA/YA	Ch.13 (SP3) Ped 2
Ch.2 (SP2) Ph. 2	Ch.6 (SP8) Ph. 6	Ch.10 (SPA2) OLB	Ch.14 (SP6) NU
Ch.3 (SP4) NU	Ch.7 (SP10) NU	Ch.11 (SPA4) NU	Ch.15 (SP9) NU
Ch.4 (SP5) NU	Ch.8 (SP11) Ph. 8	Ch.12 (SPA5) NU	Ch.16 (SP12) Ped 8

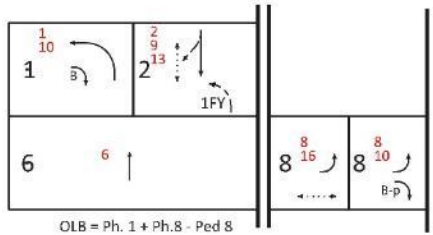

STEP 3A: LIST ALL DIODE PAIRS FOR EACH MONITOR CHANNEL IN THE SAME BOX

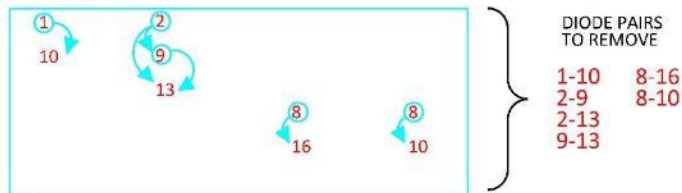

STEP 3B: START IN UPPER LEFT BOX OF THE DIAGRAM. LIST ALL DIODE PAIRS FOR EACH MONITOR CHANNEL THAT IS VERTICALLY OR DIAGONALLY OPPOSITE THE BOX (EXCEPT ANY EXCLUSIVE PHASES).

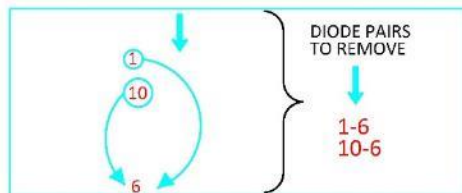

STEP 3C: REPEAT STEP 3B FOR EACH BOX ON THE UPPER ROW OF THE DIAGRAM.

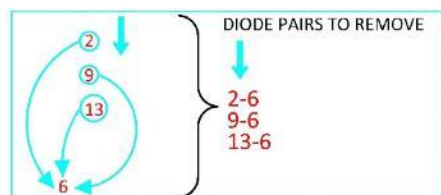

New step!!! Required for PPLT with type 3LCF signal heads WITH overlap phases

STEP 3D: CREATE A RING AND BARRIER DIAGRAM SHOWING CHANNEL FOR SOLID YELLOW ARROW OF TYPE 3LCF SIGNAL HEAD AND CHANNELS FOR OVERLAP PHASES ONLY. LIST DIODE PAIRS FOR EACH MONITOR CHANNEL IN THE SAME BOX.

List ONLY overlap phase channels & Type 3LCF head solid yellow channel!

Type 3LCF signal head:  
Ph. 1 solid yellow arrow will be monitored on ch.9 (ph. 1 FYA) because both functions (solid & FYA) are accomplished by 1 wire terminated at Ch. 9 in the output file.

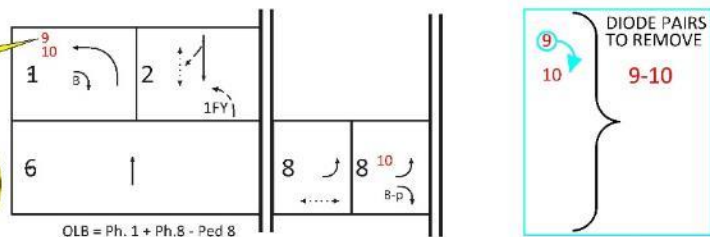
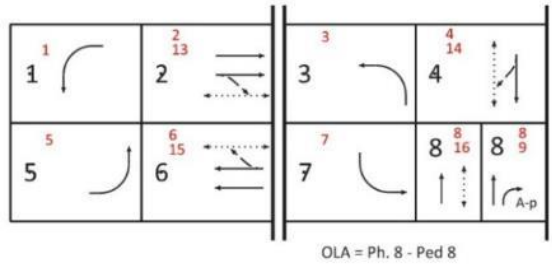

Figure 20-24 thru Figure 20-27 show common examples of determining compatible phases.

Figure 20-24 | Determining Compatible Phases – Example 1: Negative Ped Overlap

CHANNEL ASSIGNMENT							
Ch.1 (SP1)	Ph. 1	Ch.5 (SP7)	Ph. 5	Ch.9 (SPA1)	.OLA	Ch.13 (SP3)	Ped 2
Ch.2 (SP2)	Ph. 2	Ch.6 (SP8)	Ph. 6	Ch.10 (SPA2)	NU	Ch.14 (SP6)	Ped 4
Ch.3 (SP4)	Ph. 3	Ch.7 (SP10)	Ph. 7	Ch.11 (SPA4)	NU	Ch.15 (SP9)	Ped 6
Ch.4 (SP5)	Ph. 4	Ch.8 (SP11)	Ph. 8	Ch.12 (SPA5)	NU	Ch.16 (SP12)	Ped 8



STEP 3A: LIST ALL DIODE PAIRS FOR EACH MONITOR CHANNEL IN THE SAME BOX

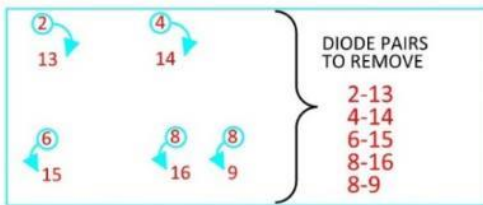

STEP 3B: START IN UPPER LEFT BOX OF THE DIAGRAM. LIST ALL DIODE PAIRS FOR EACH MONITOR CHANNEL THAT IS VERTICALLY OR DIAGONALLY OPPOSITE THE BOX (EXCEPT ANY EXCLUSIVE PHASES).

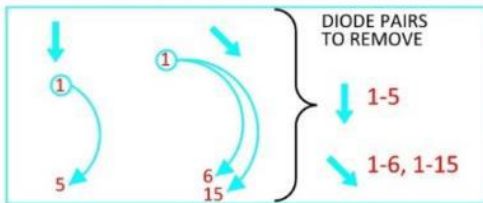

STEP 3C: REPEAT STEP 3B FOR EACH BOX ON THE UPPER ROW OF THE DIAGRAM.

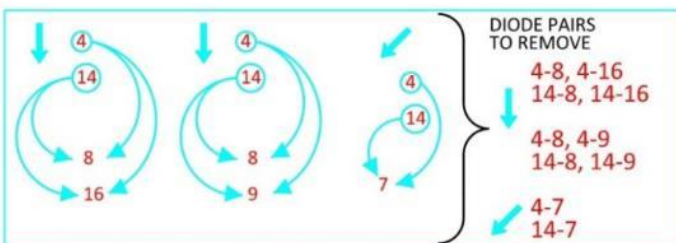
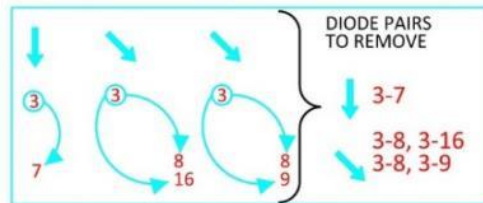
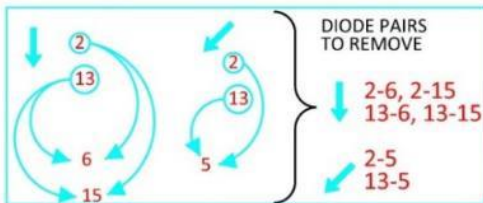

Traffic-Signal Design Manual – Cabinet Prints

Figure 20-25 | Determining Compatible Phases – Example 2: Flashing Yellow Arrow (OLD METHOD – DO NOT USE PED YELLOW FOR NEW FYA INSTALLATIONS. SEE Figure 20-23 INSTEAD)

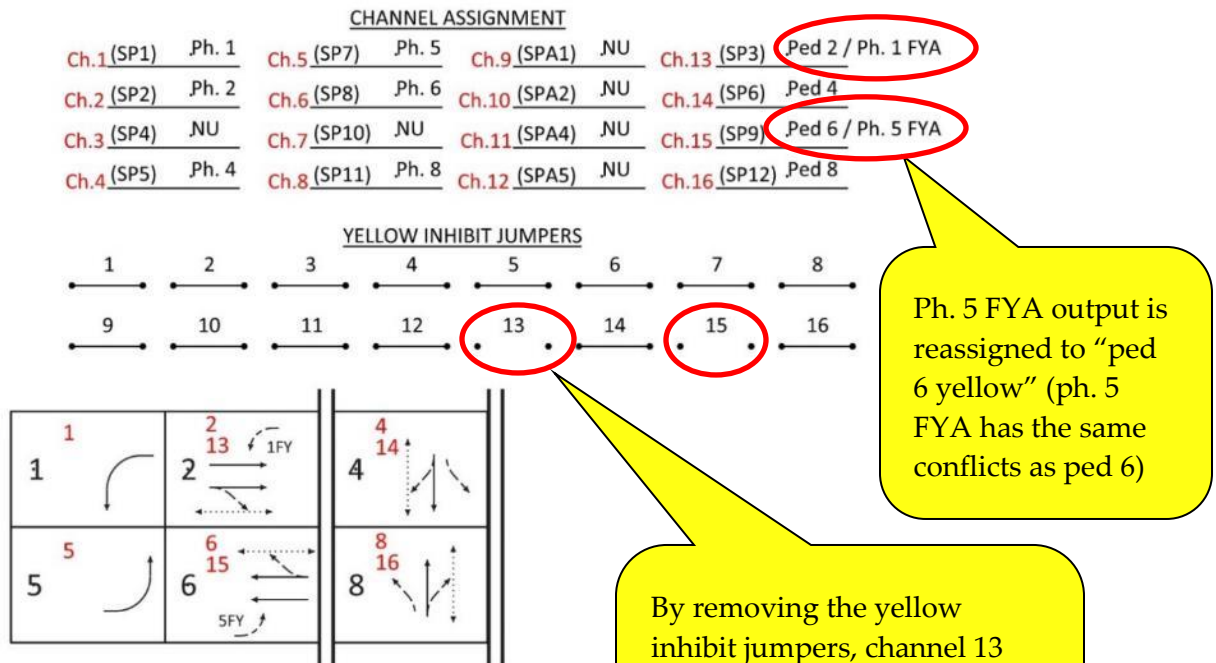

Ph. 5 FYA output is reassigned to "ped 6 yellow" (ph. 5 FYA has the same conflicts as ped 6)

By removing the yellow inhibit jumpers, channel 13 and 15 can now monitor the "ped phase yellow" (in addition to the ped phase walk)

STEP 3A: LIST ALL DIODE PAIRS FOR EACH MONITOR CHANNEL IN THE SAME BOX

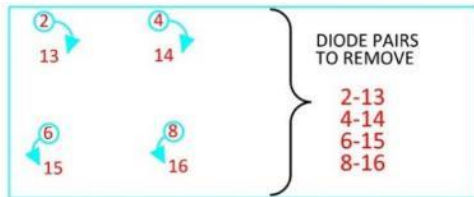

STEP 3B: START IN UPPER LEFT BOX OF THE DIAGRAM. LIST ALL DIODE PAIRS FOR EACH MONITOR CHANNEL THAT IS VERTICALLY OR DIAGONALLY OPPOSITE THE BOX (EXCEPT ANY EXCLUSIVE PHASES).

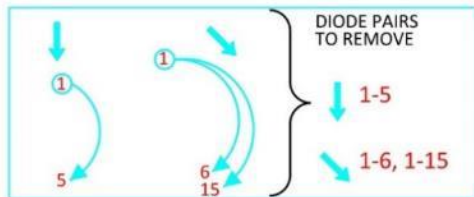

STEP 3C: REPEAT STEP 3B FOR EACH BOX ON THE UPPER ROW OF THE DIAGRAM.

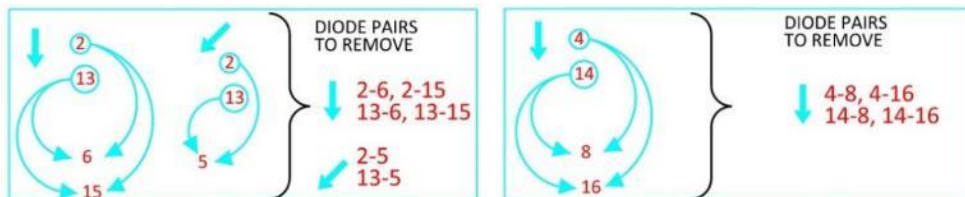
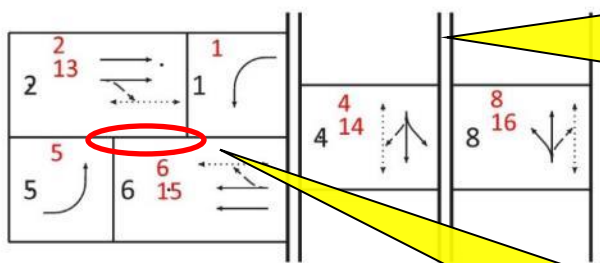

Figure 20-26 | Determining Compatible Phases – Example 3: Exclusive Phases

CHANNEL ASSIGNMENT							
Ch.1 (SP1)	Ph. 1	Ch.5 (SP7)	Ph. 5	Ch.9 (SPA1)	NU	Ch.13 (SP3)	Ped 2
Ch.2 (SP2)	Ph. 2	Ch.6 (SP8)	Ph. 6	Ch.10 (SPA2)	NU	Ch.14 (SP6)	Ped 4
Ch.3 (SP4)	NU	Ch.7 (SP10)	NU	Ch.11 (SPA4)	NU	Ch.15 (SP9)	Ped 6
Ch.4 (SP5)	Ph. 4	Ch.8 (SP11)	Ph. 8	Ch.12 (SPA5)	NU	Ch.16 (SP12)	Ped 8



Phase 4 and phase 8 are exclusive phases (there are no compatible phases located vertically or diagonally on the same side of the barrier).

Phase 1 and 5 are NOT compatible as drawn (a diagonal line would not go directly from phase 1 to 5 without passing thru the phase 2 or phase 6 boxes). See chapter 3 for more info.

STEP 3A: LIST ALL DIODE PAIRS FOR EACH MONITOR CHANNEL IN THE SAME BOX

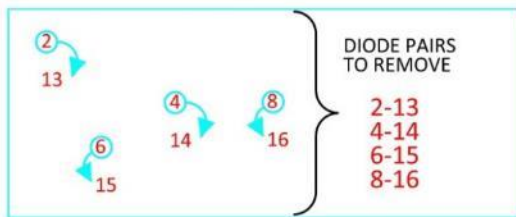

STEP 3B: START IN UPPER LEFT BOX OF THE DIAGRAM. LIST ALL DIODE PAIRS FOR EACH MONITOR CHANNEL THAT IS VERTICALLY OR DIAGONALLY OPPOSITE THE BOX (EXCEPT ANY EXCLUSIVE PHASES).

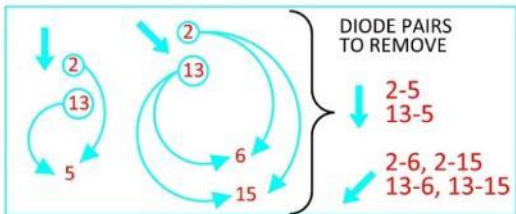

STEP 3C: REPEAT STEP 3B FOR EACH BOX ON THE UPPER ROW OF THE DIAGRAM.

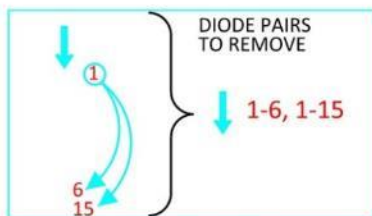

Phase 4 and phase 8 are exclusive phases (no other phases are compatible).

Figure 20-27 | Determining Compatible Phases – Example 4: Railroad Preemption Type 7 Signal Head

CHANNEL ASSIGNMENT					
Ch.1 (SP1)	Ph. 1	Ch.5 (SP7)	Ph. 5	Ch.9 (SPA1)	NU
Ch.2 (SP2)	Ph. 2	Ch.6 (SP8)	Ph. 6	Ch.10 (SPA2)	NU
Ch.3 (SP4)	NU	Ch.7 (SP10)	Ph. 7	Ch.11 (SPA4)	NU
Ch.4 (SP5)	Ph. 4	Ch.8 (SP11)	Ph. 8	Ch.12 (SPA5)	NU
				Ch.13 (SP3)	Ped 2
				Ch.14 (SP6)	Ped 4
				Ch.15 (SP9)	Ped 6
				Ch.16 (SP12)	Ped 8

Don't forget to include the phase that is only active during the VCOI

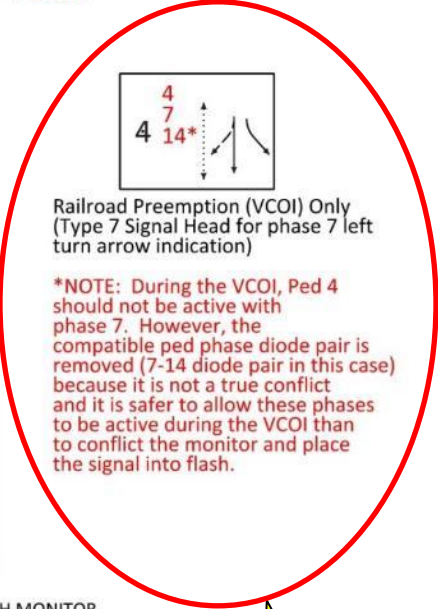
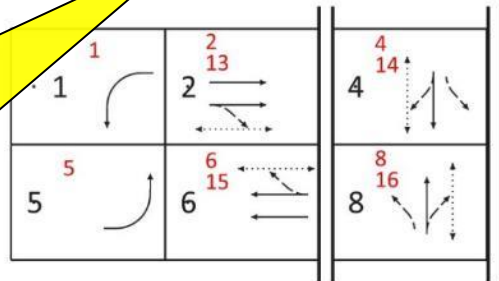

STEP 3A: LIST ALL DIODE PAIRS FOR EACH MONITOR CHANNEL IN THE SAME BOX



STEP 3B: START IN UPPER LEFT BOX OF THE DIAGRAM. LIST ALL DIODE PAIRS FOR EACH MONITOR CHANNEL THAT IS VERTICALLY OR DIAGONALLY OPPOSITE THE BOX (EXCEPT ANY EXCLUSIVE PHASES).

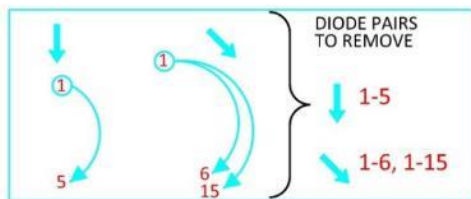

STEP 3C: REPEAT STEP 3B FOR EACH BOX ON THE UPPER ROW OF THE DIAGRAM.

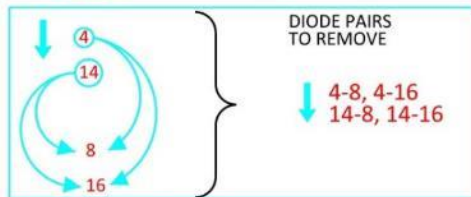
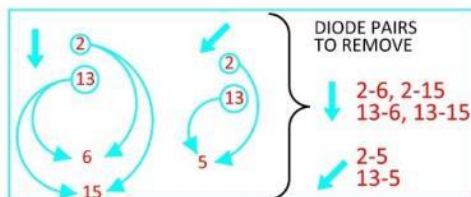

Don't forget to include the phase that is only active during the VCOI



## 20.7.4 Auxiliary Output File (Front and Back View)

The auxiliary output file location comes standard in 332S cabinets (optional in 332 cabinets) and provides additional outputs if more are needed. Unused locations should be left blank. It is filled out the same way as the main output file. See Figure 20-28.

Figure 20-28 | Auxiliary Output File (Front and Back View)

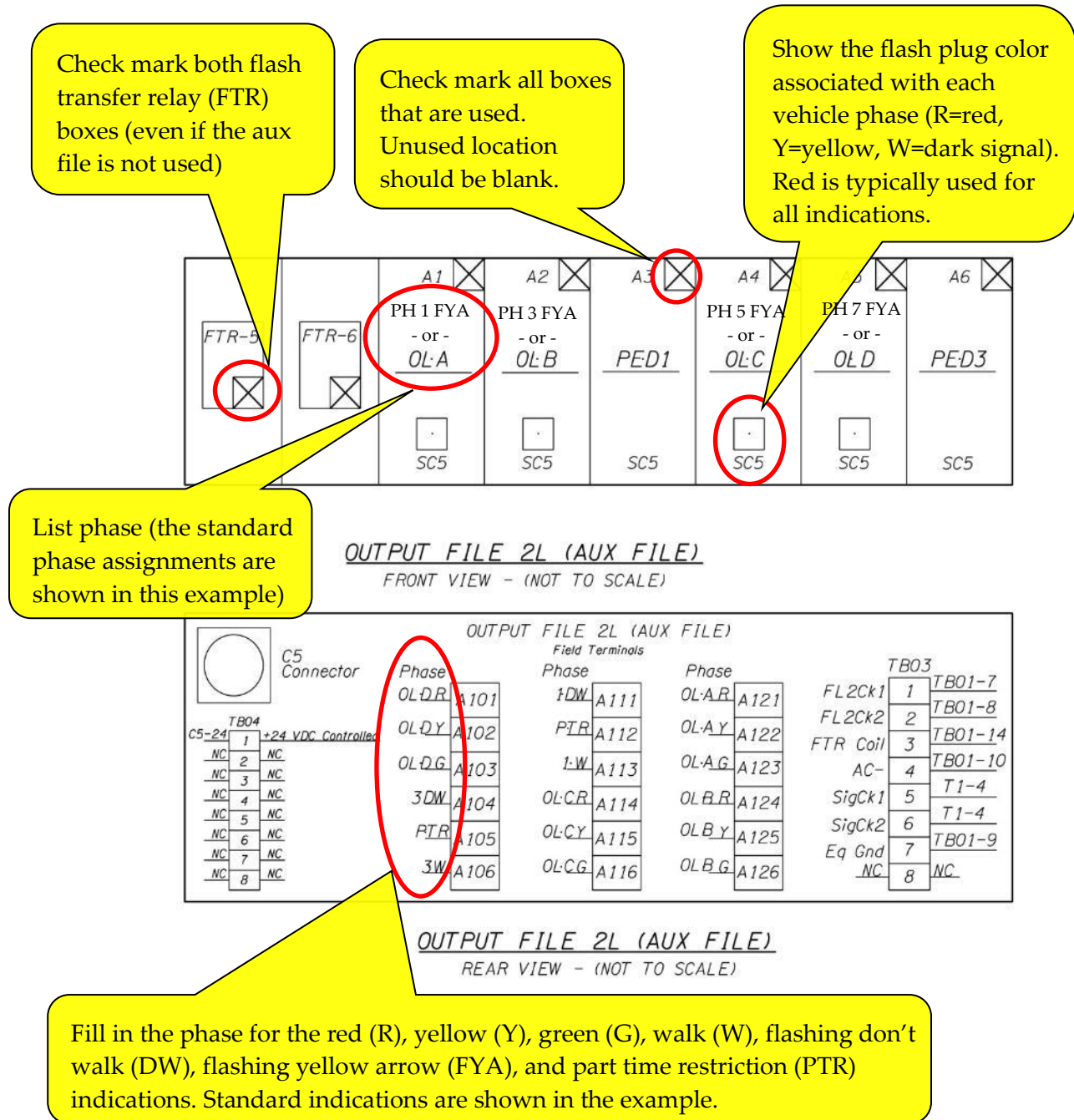

## 20.7.5 Additional Information for the Output File

- The standard 332S (and 332 and 336) cabinets can accommodate 8 vehicle phases and 4 pedestrian phases (a total of 12 load switches). An additional 4 vehicle phase and 2 pedestrian phases (a total of 6 additional load switches) are available if needed in the auxiliary output file of the 332S and 332 cabinet (The auxiliary output file comes standard in the 332S cabinet and is optional in the 332 cabinet). There is a standard phase layout for the output file. However, most intersection software programs allow the flexibility to assign any phase, pedestrian phase, overlap or special use output to any output location in the output files.
- Sixteen (of the 18 total) load switches are conflict monitored. The load switches in the auxiliary file slot A3 and A6 are not monitored.
- Pedestrian output locations will always be in load switch location 3, 6, 9, and 12 of the main output file and A3 and A6 of an auxiliary output file. The reason for this is that the flash power is not routed to these load switch locations, which allows the pedestrian signal indications to remain dark while the signal is operating in emergency flash mode. Vehicle signal indication should not be reassigned to these slots as they should not remain dark in flashing mode.
- PTR signs should terminate on the phase 1 ped yellow output of the auxiliary output file, switch pack location A3. Note: in the past, PTR signs for rail preemption (the typical installation) were normally terminated on the phase 4 ped yellow output (or any other unused ped yellow output if the phase 4 ped didn't exist) to avoid installation of an auxiliary file.
- The conflict monitor is limited to a total of 16 channels which limits the number of phases that can be used at an intersection. The flashing yellow arrow indication (for a protected/permitted left turn phase) is assigned to the channels normally reserved for overlap phases. As such, the number of protected/permitted left turn phases and vehicle overlap phases at an intersection will be limited to a combined total of four. For example, typical maximum combinations an intersection can have:
  - PPLT for phases 1, 3, 5, and 7 with NO overlap phases
  - Four overlap phases with NO PPLT
  - PPLT for phases 1 and 5 with two overlap phases
  - PPLT for phases 3 and 7 with two overlap phases

Exceptions to combined total of four may be acceptable in the rare circumstance where there is an unused vehicle phase output that an overlap phase can be reassigned to (channels 1 thru 8). The flashing yellow arrow indications should only be wired to channels 9 thru 12 as shown in Figure 20-20.

Assigning flashing yellow arrow to pedestrian yellow outputs will no longer be allowed as it can result in problematic conflict monitoring when used in conjunction with overlaps, negative ped phasing and type 3LCF signal heads. See Section 20.13.1 for additional background/reference info.

- Flash plugs are used with the output file to enable the correct indication to flash while the signal is operating in emergency flash mode (e.g., cabinet flash). Red flash plugs enable the red indication to flash, and yellow flash plugs enable the yellow indication to flash. White flash plugs shall be used to bypass the flash power if a standard vehicle phase output (switch pack locations 1, 2, 4, 5, 7, 8, 10, 11, A1, A2, A4, and A5) has been reassigned to a pedestrian phase so that the reassigned pedestrian indications will remain dark while the signal is operating in emergency flash mode. The default standard is to use red flash plugs for all load switch locations that serve vehicle phases; standard pedestrian phase load switch locations do not use flash plugs and are already wired to bypass the flash power. If something other than default standard red flash plugs are used, it shall be noted on the switch pack location as “Y” (for yellow) or “W” (for no-flash).

## 20.7.6 Output File & Conflict Monitor Configuration for PHBs

Pedestrian hybrid beacons (PHBs) require a unique output file and conflict monitoring set-up. See Figure 20-29 for a single stage ped crossing and Figure 20-30 for a two-stage ped crossing.

Figure 20-29 | PHB Output File and Conflict Monitor Configuration – Single Stage Ped Crossing

### PHB: 1 Crossing Output File & Conflict Monitor Configuration

*As per normal convention, we monitor*  
 1. vehicular green (which = DARK in this case),  
 2. vehicular flashing yellow (Solid yellow is same output in this case)  
 3. ped walk

*As per normal convention, vehicular red, flashing red and Ped Flashing DONT WALK are unmonitored*

*In the event of a conflict, the cabinet shall flash YELLOW*

*Basic Software Logic:*  
 If both Ph. 1 Red outputs are OFF, Turn ON output Dummy Ph. 1 DARK.

*HARDWARE: NEED A FAKE LOAD ON DUMMY OUTPUTS (20W Load Resistor)*

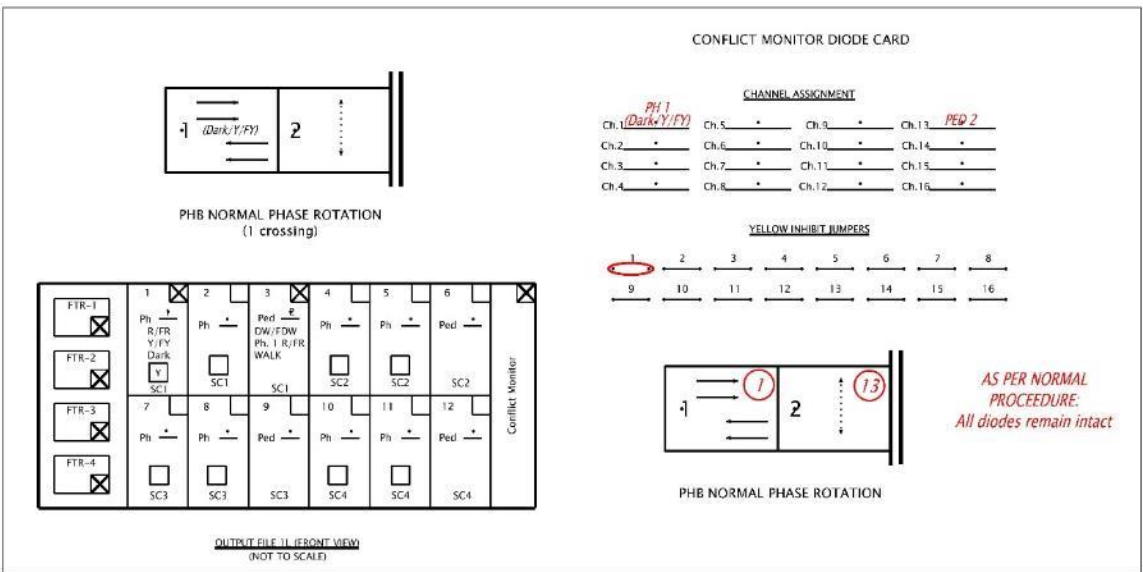

### SEQUENCE OF OPERATIONS

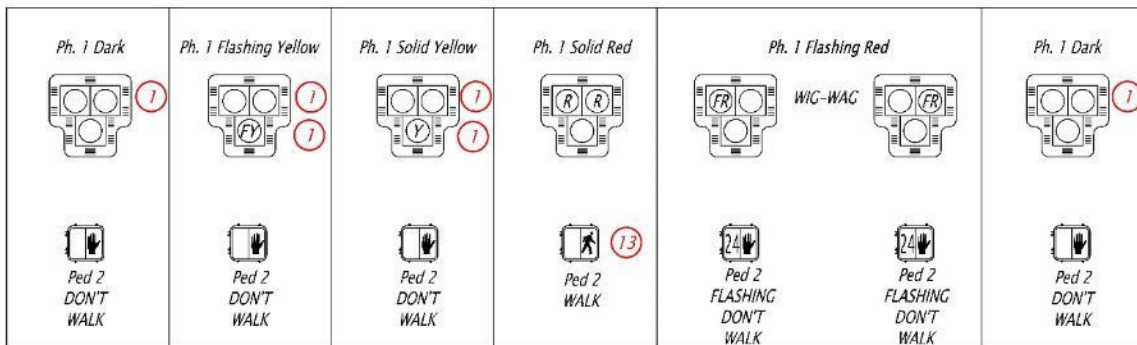

Figure 20-30 | PHB Output File and Conflict Monitor Configuration – Two-Stage Ped Crossing

PHB: 2 Crossings Output File & Conflict Monitor Configuration

As per normal convention, we monitor  
 1.vehicular green (which = DARK in this case),  
 2.vehicular flashing yellow (Solid yellow is same output in this case)  
 3. ped walk

As per normal convention, vehicular red, flashing red and Ped Flashing DONT WALK are unmonitored

In the event of a conflict, the cabinet shall flash YELLOW

**Basic Software Logic:**  
 If both Ph. 1 Red outputs are OFF, Turn ON output Dummy Ph. 1 DARK.  
 If both Ph. 5 Red outputs are OFF, Turn ON output Dummy Ph. 5 DARK.

**HARDWARE: NEED A FAKE LOAD ON DUMMY OUTPUTS (20W Load Resistor)**

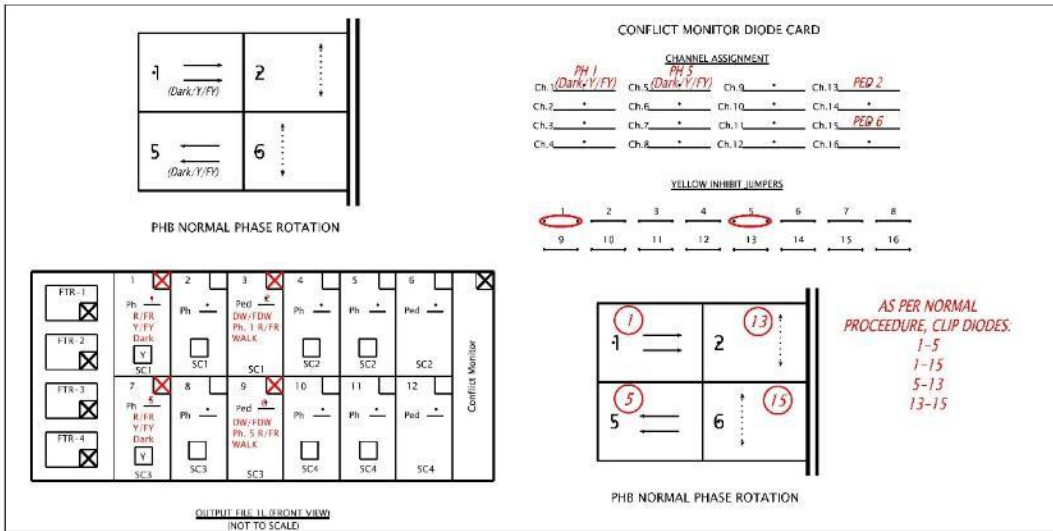

SEQUENCE OF OPERATIONS

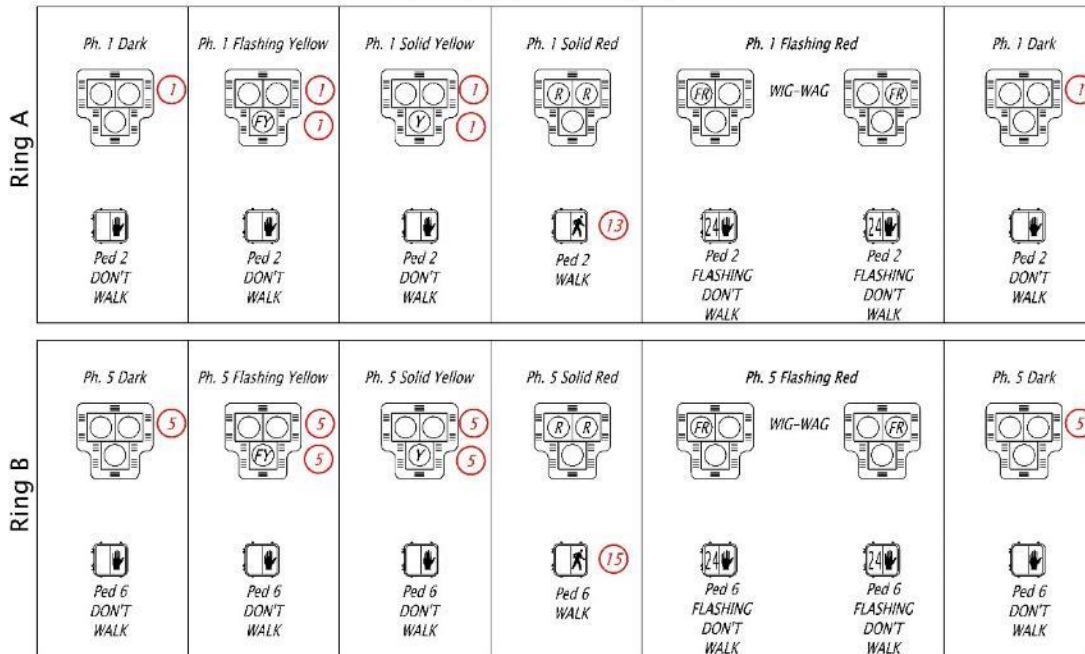

# 20.8 332S Cabinet Print (Page 4 – C1 Pin Assignments & Test Switch)

Page 4 of the cabinet print shows the C1 pin assignments and test switch details. This sheet generally doesn't require any modification. See Figure 20-31.

Figure 20-31 | 332S Cabinet Print (Page 4 – C1 Pin Assignments & Test Switch)

Program Assign Functions	C1 Connector Pins	C4 Connector Terminations	Switch Pack Pin	Field Term.
DC Gnd	1	DC Gnd Bus	--	--
0.4 DWALK	2	C4-1	1	6-DW 3 104
0.4 WALK	3	C4-2	2	6-W 7 106
0.4 RED	4	C4-3	3	6-R 3 101
0.4 YELLOW	5	C4-4	4	6-Y 5 102
0.4 GREEN	6	C4-5	5	6-G 7 103
0.3 RED	7	C4-6	6	4-R 3 116
0.3 YELLOW	8	C4-7	7	4-Y 5 117
0.3 GREEN	9	C4-8	8	4-G 7 118
0.2 DWALK	10	C4-9	9	3-DW 3 113
0.2 WALK	11	C4-10	10	3-W 7 115
0.2 RED	12	C4-11	11	6-R 3 108
0.2 YELLOW	13	C4-12	12	6-Y 5 109
0.2 GREEN	14	TERMIN-4"	--	--
Input Gnd	15	TERMIN-4"	--	--
0.2 RED	16	C4-13	13	2-G 7 130
0.1 RED	17	C4-14	14	1-R 3 125
0.1 YELLOW	18	C4-15	15	1-Y 5 126
0.1 GREEN	19	C4-16	16	1-G 7 127
0.0 DWALK	20	C4-17	17	6-DW 3 110
0.0 WALK	21	C4-18	18	12-W 7 112
0.0 RED	22	C4-19	19	6-R 3 107
0.0 YELLOW	23	C4-20	20	6-Y 5 108
0.0 GREEN	24	C4-21	21	11-G 7 109
0.7 RED	25	C4-22	22	6 10-R 3 128
0.7 YELLOW	26	C4-23	23	6 10-Y 5 123
0.7 GREEN	27	C4-24	24	10-G 7 124
0.6 DWALK	28	C4-25	25	6 9-DW 3 119
0.6 WALK	29	C4-26	26	10 9-W 7 121
0.6 RED	30	C4-27	27	6 8-R 3 134
0.6 YELLOW	31	C4-28	28	6 8-Y 5 135
0.6 GREEN	32	C4-29	29	10 8-G 7 136
0.5 RED	33	C4-30	30	6 7-R 3 131
0.5 YELLOW	34	C4-31	31	6 7-Y 5 132
0.5 GREEN	35	C4-32	32	7-G 7 133
0.1 FLTYA	36	C4-33	33	3-Y 5 114
0.3 FLTYA	37	C4-34	34	6-Y 5 120
0.3 FLTYA	38	C4-35	35	6-Y 5 105
0.7 FLTYA	39	C4-36	36	12-Y 5 111

Program Assign Functions	C1 Connector Pin	Termination	Out	In	Field Terminals
0.2 DET	39	J3-1	F	DME	T85-5810
0.4 DET	40	J3-1	F	DME	T85-5810
0.4 DET	41	J8-1	F	DME	T85-29630
0.2 DET	42	J8-1	F	DME	T85-29630
0.2 DET	43	J3-2	W	J&K	T85-11612
0.4 DET	44	J3-2	W	J&K	T85-11612
0.4 DET	45	J8-2	W	J&K	T85-11632
0.2 DET	46	J8-2	W	J&K	T85-11632
0.2 DET	47	J3-2	W	J&K	T85-17618
0.6 DET	48	J5-1	F	DME	T85-17618
0.4 DET	49	J10-1	F	DME	T85-37638
0.2 DET	50	J10-1	F	DME	T85-37638
PROJ	51	J12-1	F	O	T80-2
VDD1	52	J12-2	W	J	T80-3
ADV ENABLE	53	--	--	--	T81-11
SPARE	54	J11-1	F	DME	T85-5810
0.5 DET	55	J11-1	F	DME	T85-182
0.7 DET	56	J1-1	F	DME	T85-182
0.7 DET	57	J6-1	F	DME	T85-2182
0.3 DET	58	J6-1	F	DME	T85-2182
0.5 DET	59	J1-2	W	J&K	T85-384
0.7 DET	60	J1-2	W	J&K	T85-384
0.7 DET	61	J6-2	W	J&K	T85-2384
0.3 DET	62	J6-2	W	J&K	T85-2384
0.2 DET	63	J4-1	F	DME	T85-1384
0.4 DET	64	J4-1	F	DME	T85-1384
0.4 DET	65	J9-1	F	DME	T85-3384
0.4 DET	66	J9-1	F	DME	T85-3384
Pin 2 Pwd	67	J14-1	F	O	T81-4
Pin 4 Pwd	69	J13-2	W	J	T81-2
Pin 8 Pwd	70	J14-2	W	J	T81-5
EV0	71	J13-1	F	O	T83-3
EV0	72	J14-1	F	O	T83-6
EV0	73	J13-2	W	J	T83-4
EV0	74	J14-2	W	J	T83-7
0.2 DET	75	J12-2	W	J&K	T85-11612
0.6 DET	76	J4-2	W	J&K	T85-15816
0.4 DET	77	J4-2	W	J&K	T85-15816
0.4 DET	78	J9-2	W	J&K	T85-35816
0.2 DET	79	J9-2	W	J&K	T85-35816
Advance	80	--	--	--	T81-10
Flash Sense	81	--	--	--	T81-7
Shop Time	82	--	--	--	T81-8

Program Assign Functions	C1 Connector Pin	Termination	Pin	Switch Pack Pin	Field Term.
0.3 DWALK	83	C5-1	1	6	A6-DW 3 A104
0.3 WALK	84	C5-2	2	10	A6-W 7 A106
0.4 RED	85	C5-3	3	6	A5-R 3 A101
0.4 YELLOW	86	C5-4	4	8	A5-Y 5 A102
0.4 GREEN	87	C5-5	5	10	A5-G 7 A103
0.4 RED	88	C5-6	6	6	A4-R 3 A114
0.4 YELLOW	89	C5-7	7	8	A4-Y 5 A115
0.4 GREEN	90	C5-8	8	10	A4-G 7 A116
0.1 DWALK	91	C5-9	9	6	A3-DW 3 A111
DC Gnd	92	DC Gnd Bus	--	--	--
0.1 WALK	93	C5-10	10	10	A3-W 7 A113
0.1 RED	94	C5-11	11	6	A2-R 3 A124
0.1 YELLOW	95	C5-12	12	8	A2-Y 5 A125
0.1 GREEN	96	C5-13	13	10	A2-G 7 A126
0.4 RED	97	C5-14	14	6	A1-R 3 A121
0.4 YELLOW	98	C5-15	15	8	A1-Y 5 A122
0.4 GREEN	99	C5-16	16	10	A1-G 7 A123
PTX SIGN	100	C5-17	17	8	A6-Y 5 A105
PTX SIGN	101	C5-18	18	8	A3-Y 5 A112
FLASH OUT	102	T815-3"	--	--	--
Watchdog	103	C4-37	--	--	Monitor-Pin E2
Input Gnd	104	TERMIN-4"	--	--	--

Program Assign Functions	C11 Connector Pin	Termination	Out	In	Field Terminals
MT ASSGN	1,8	T&B	--	--	--
DC Gnd	9	DC Gnd Bus	--	--	--
0.2 DET	10	J5-2	W	J&K	T85-19820
0.6 DET	11	J9-2	W	J&K	T85-19820
0.4 DET	12	J10-2	W	J&K	T85-39840
0.8 DET	13	J10-2	W	J&K	T85-39840
DC Gnd	14	DC Gnd Bus	--	--	--
0.3 DET	15	J6-1	F	DME	T85-586
0.1 DET	16	J2-1	F	DME	T85-586
0.7 DET	17	J7-1	F	DME	T85-2586
0.3 DET	18	J7-1	F	DME	T85-2586
0.5 DET	19	J8-2	W	J&K	T85-788
0.1 DET	20	J2-2	W	J&K	T85-788
0.7 DET	21	J7-2	W	J&K	T85-2788
0.3 DET	22	J7-2	W	J&K	T85-2788
SPARE	23	J11-1	F	DME	T85-182
SPARE	24	J12-1	F	DME	T85-586
SPARE	25	J11-2	W	J&K	T85-384
SPARE	26	J12-2	W	J&K	T85-788
MT ASSGN	27-30	T&B	--	--	--
DC Gnd	31	DC Gnd Bus	--	--	--
MT ASSGN	32-36	T&B	--	--	--
DC Gnd	37	DC Gnd Bus	--	--	--

C1 PLUG PINOUT

C11 PLUG PINOUT

Detector Test Panel Wiring Typical Wiring Diagram

This sheet should not be modified

PAGE 4 OF 6	CONTROLLER (C1),C11) WIRING DETAILS	REV. NO.	DATE	ISSUE	REVISION	INTERSECTION: Main Street @ Cross Street, Any Town	OREGON DEPARTMENT OF TRANSPORTATION
		1	09/30/19	JS	Added a jumper from 11X to 11R, back of Input Tab	HW: XXX, M.P: XXX, XX TSSU: XXXXX	332S CDDT CABINET PRINT
							REV: 09/20/22

# 20.9 332S Cabinet Print (Page 5 – Electrical Diagrams)

Page 5 of the cabinet print shows the electrical diagram details. This sheet generally doesn't require any modification. See Figure 20-32.

Figure 20-32 | 332S Cabinet Print (Page 5 – Electrical Diagrams)

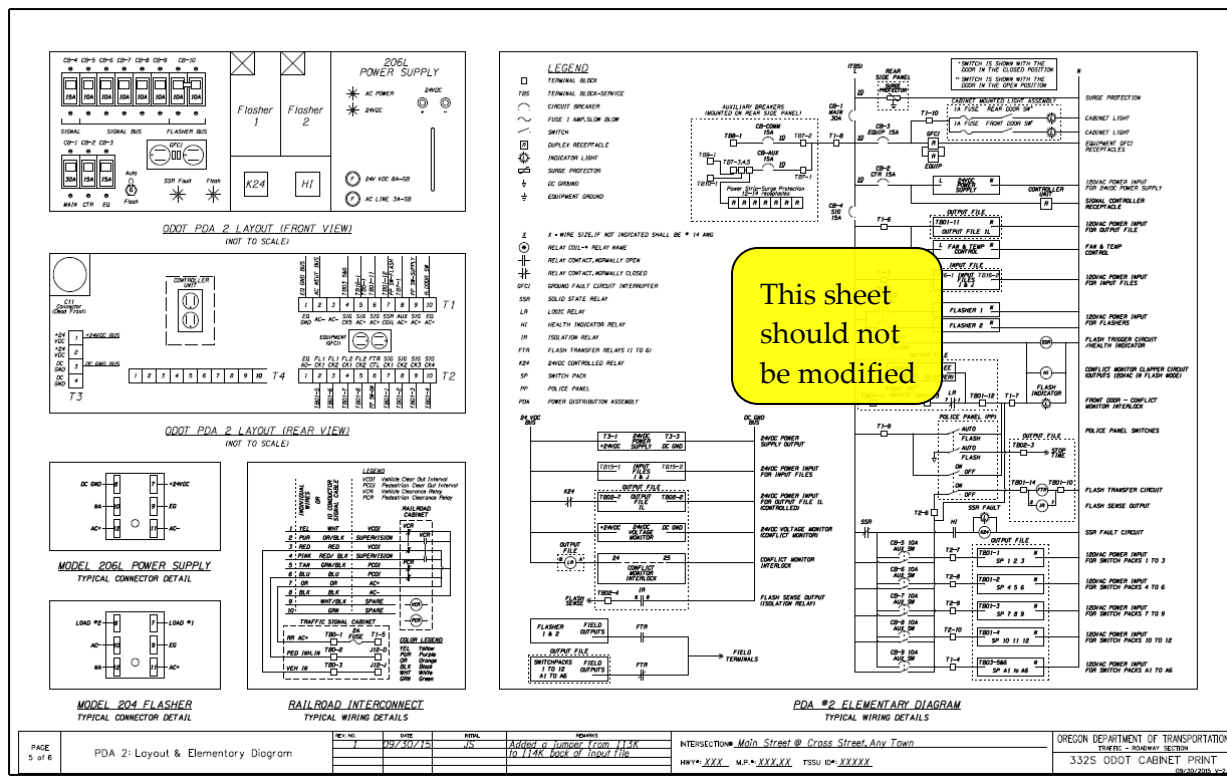

# 20.10 332S Cabinet Print (Page 6 – Intersection Drawing)

Page 6 of the cabinet print shows the intersection drawing. The intent of the intersection drawing is to provide a simplified illustration of critical signal equipment and operations to allow the field tech to quickly determine the orientation and location of equipment during routine maintenance and troubleshooting. It may seem redundant to provide an intersection drawing as part of the cabinet print given the contract plan sheet(s) contain the same (plus additional) info, but it is very valuable to highlight only the relevant maintenance information on a single sheet (or two sheets if necessary) for efficient fieldwork. **THIS SHEET NO LONGER SHOWS DETECTION INFO. THIS INFORMATION IS NOW SHOWN ON SHEET 7.**

The intersection drawing is created from the design file and is copied (not referenced) into the cabinet print file. This is to allow for easy future modification and archiving of the cabinet print file without reference files.

The intersection drawing should include the following. See Figure 20-33 to Figure 20-35:

- Plan view of intersection. This is typically the same orientation as plan sheet, with the mainline parallel to long edge of the page (17" side). It should also match orientation of the plan view shown on page 7 of cabinet print.
- North arrow
- Street names
- Operation items:
  - Lanes and lane use arrows
  - Phasing, labeled in each lane
  - Crosswalks, labeled in each crosswalk
  - Phase rotation diagram (ring and barrier style required. Note: older cabinet prints not using a standard ring and barrier diagram shall be updated)
  - Fire preemption diagram
- Equipment:
  - Signal poles with mast arms/span wires
  - Pedestals
  - Other poles that contain signal equipment controlled by the cabinet (e.g., a remote fire preemption unit, advance flashing beacons, etc.)
  - Signal heads and pedestrian heads
  - Emergency preemption devices, labeled per device
  - Controller cabinet, labeled
  - Communications gear located on TB8, TB9, or TB10
- Railroad items (see Figure 20-34):
  - Railroad controller cabinet, labeled
  - Railroad tracks, labeled
  - PTR signs, labeled per device
- Reference to all relevant contract plan sheets related to the intersection
- List of intersections that are interconnected

The intersection drawing should be simple, uncluttered and easy to read. To achieve this, do NOT include the following:

- Detection information (now shown separately on sheet 7)
- Right-of-way lines
- Conduit
- Utilities
- Stationing
- Bubble notes & legend



### **Traffic-Signal Design Manual – Cabinet Prints**

The scale of all features shown on the intersection drawing is flexible to maximize readability while still containing all the information needed. TSSU and region electricians may request modifications to what is included or not included on the intersection drawing depending on the intersection complexity, uniqueness, or staff preference. In general, modifications are allowed, but are reviewed and informally approved by traffic engineering section.

Figure 20-33 | 332S Cabinet Print (Page 6 – Intersection Drawing) Example 1

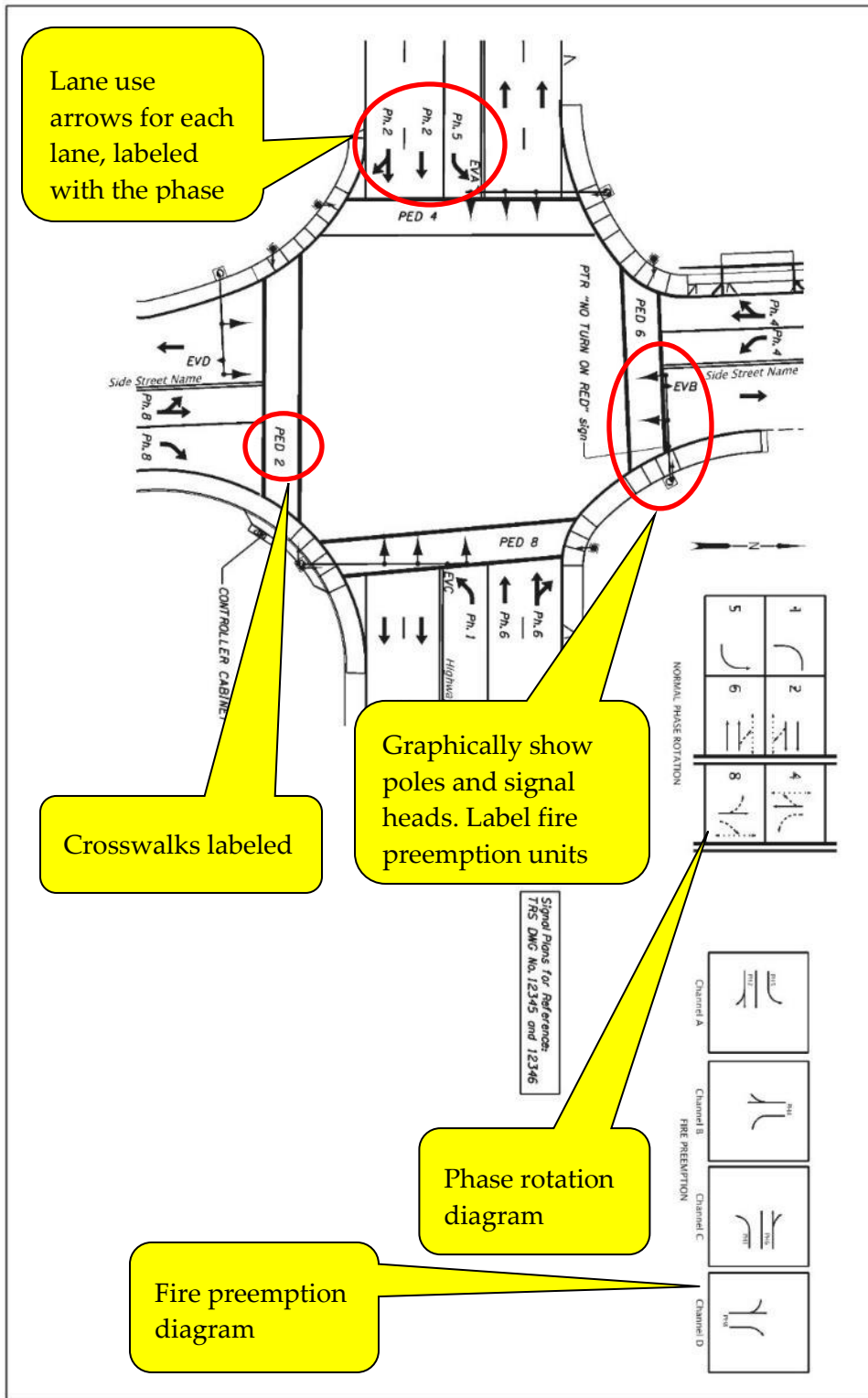

Figure 20-34 | 332S Cabinet Print (Page 6 – Intersection Drawing) Example 2

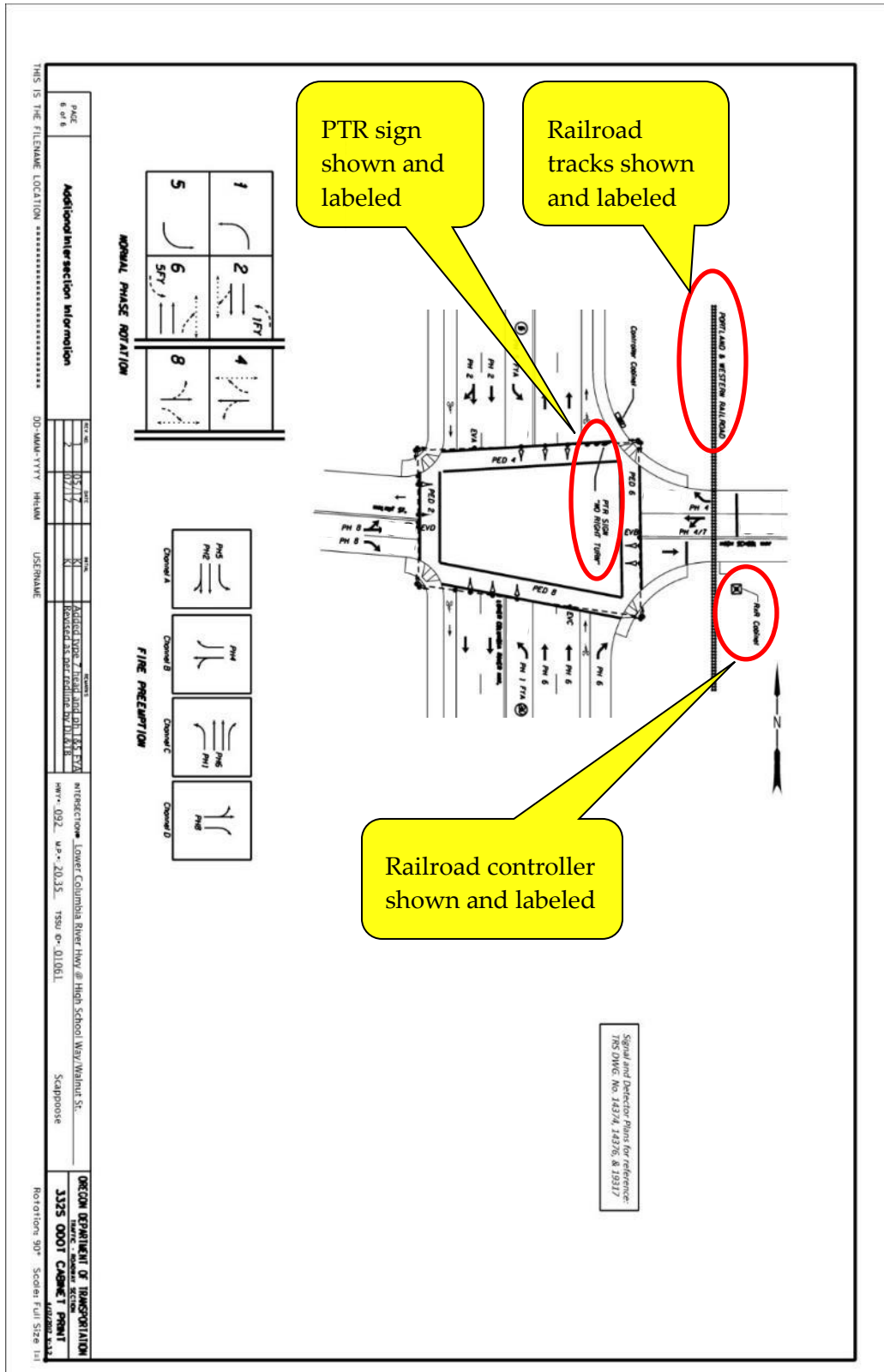
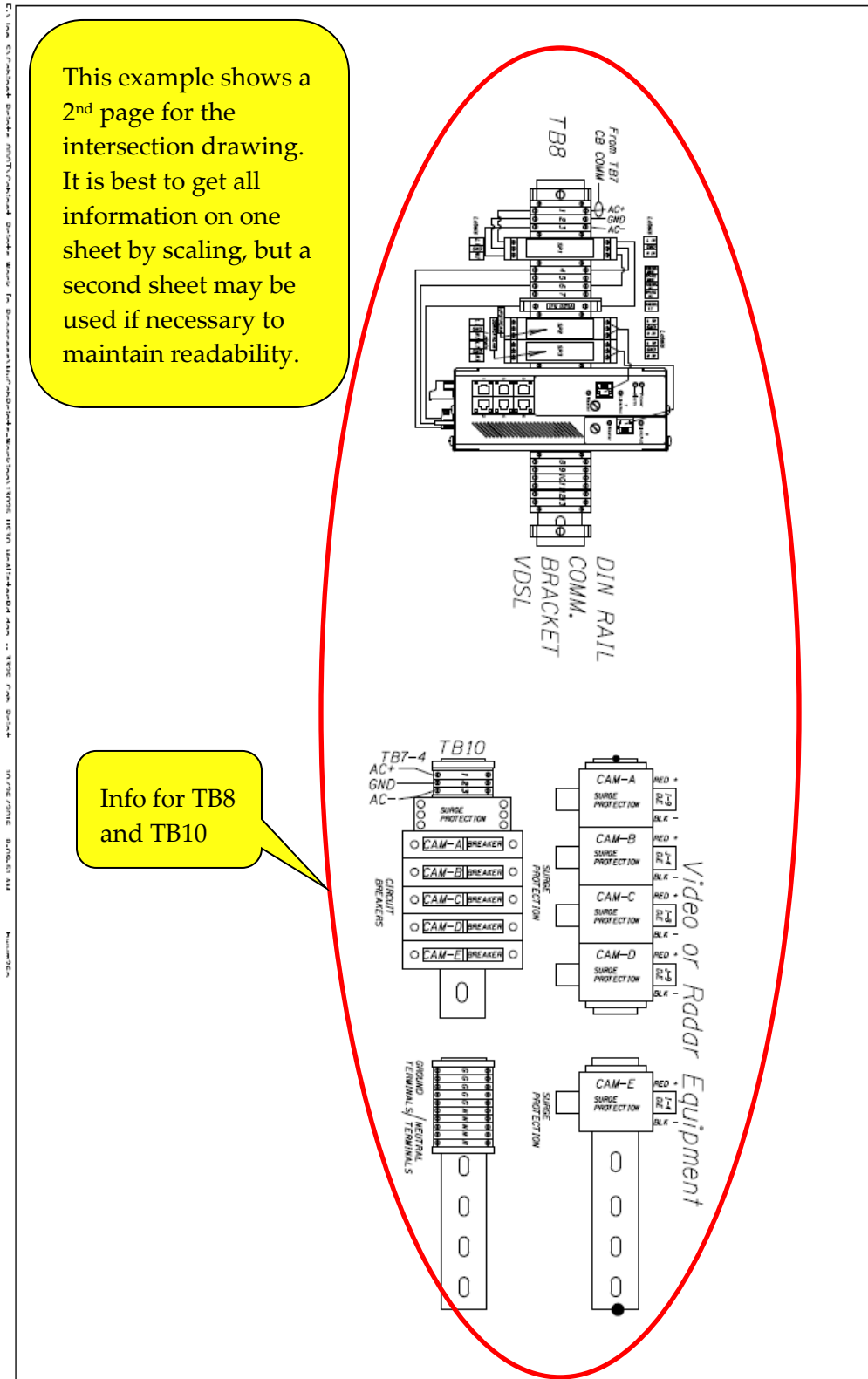

Figure 20-35 | 332S Cabinet Print (Page 6 – Intersection Drawing) Example 3



## 20.11 332S Cabinet Print (Page 7 – Detection Drawing)

Page 7 of the cabinet print shows the detection drawing. The intent of the detection drawing is to provide a general illustration of detection units, coverage areas, and/or zones and software detection configuration information to allow efficient maintenance and troubleshooting. Showing the detection info on a separate sheet from the intersection drawing helps with readability and field workflow.

The detection drawing is created from the design file and is copied (not referenced) into the cabinet print file. This is to allow for easy future modification and archiving of the cabinet print file without having reference files.

The detection drawing should include the following. See Figure 20-36 to Figure 20-37:

- Plan view of intersection. This is typically the same orientation as plan sheet, with the mainline parallel to long edge of the page (17" side). It should also match orientation of the plan view shown on page 6 of cabinet print.
- North arrow
- Street names
- Note on detection zones (one for if zones are shown, one for if they are not)
- Function legend
- Operation items:
  - Lanes and lane use arrows
  - Near-side radar coverage area (cone shape), labeled
  - Passive pedestrian detection zones, labeled
  - **Detection zones, not labeled – ONLY IF REQUESTED BY THE SIGNAL TIMER!**
  - **Import excel file of detector configuration from signal timer. See [Instructions for Signal Timers and Designers](#) for additional information.**
- Equipment:
  - Signal poles with mast arms/span wires or pedestals where detector units are mounted
  - Detector units, labeled
  - Controller cabinet, labeled
  - Loops with loop numbers (for advance loops only indicate the distance from stop line)
- Railroad items:
  - Railroad tracks

The detection drawing should be simple, uncluttered and easy to read. To achieve this, do NOT include the following:

- Information shown on the intersection drawing on page 6
- Right-of-way lines
- Conduit
- Utilities
- Stationing
- Bubble notes & legend

The scale of all features shown on the intersection drawing is flexible to maximize readability while still containing all the information needed. TSSU and region electricians may request modifications to what is included or not included on the detection drawing depending on the intersection complexity, uniqueness, or staff preference. In general, modifications are allowed, but are reviewed and informally approved by traffic engineering section.

Figure 20-36 | 332S Cabinet Print (Page 7 – Detection Drawing) Example 1

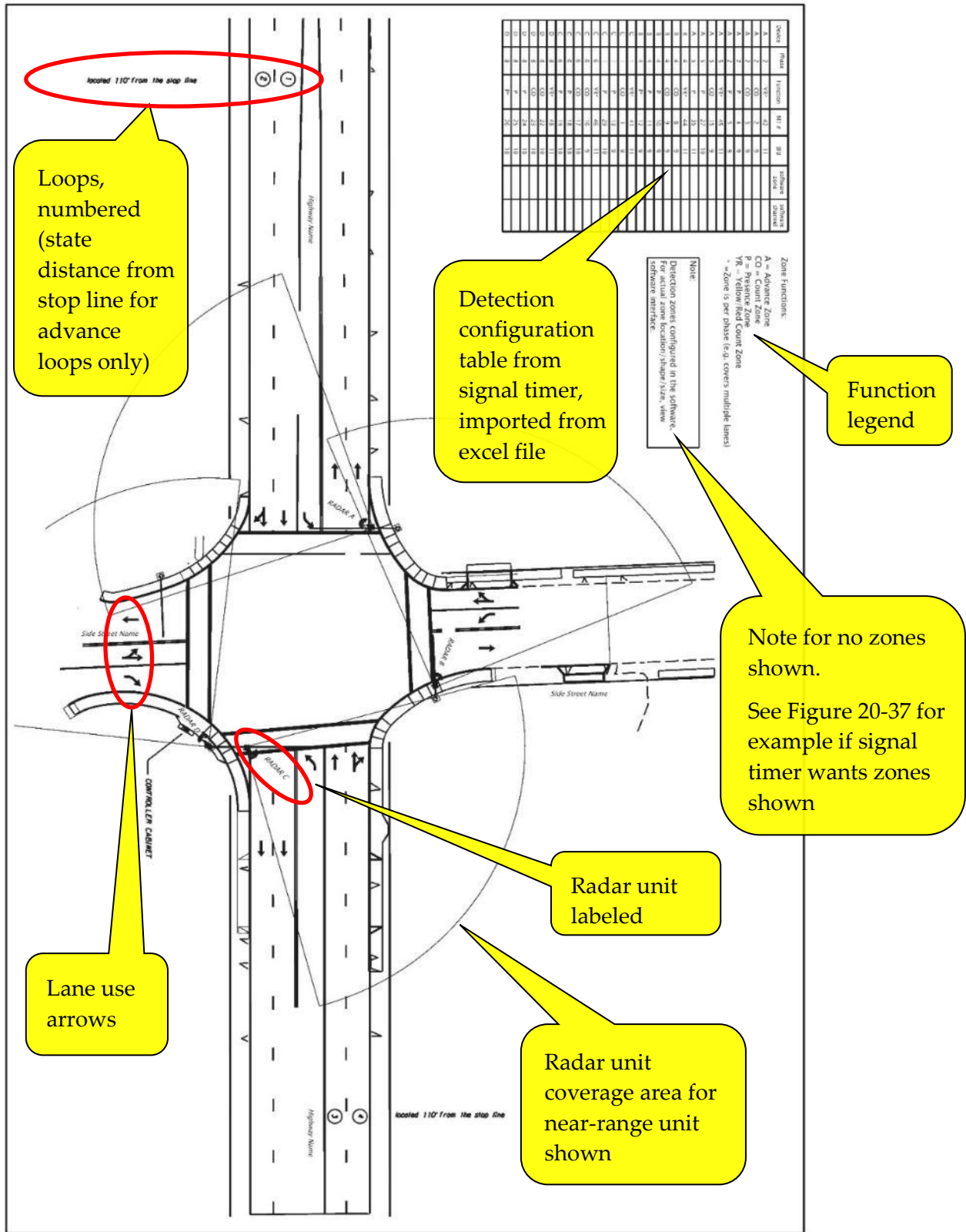
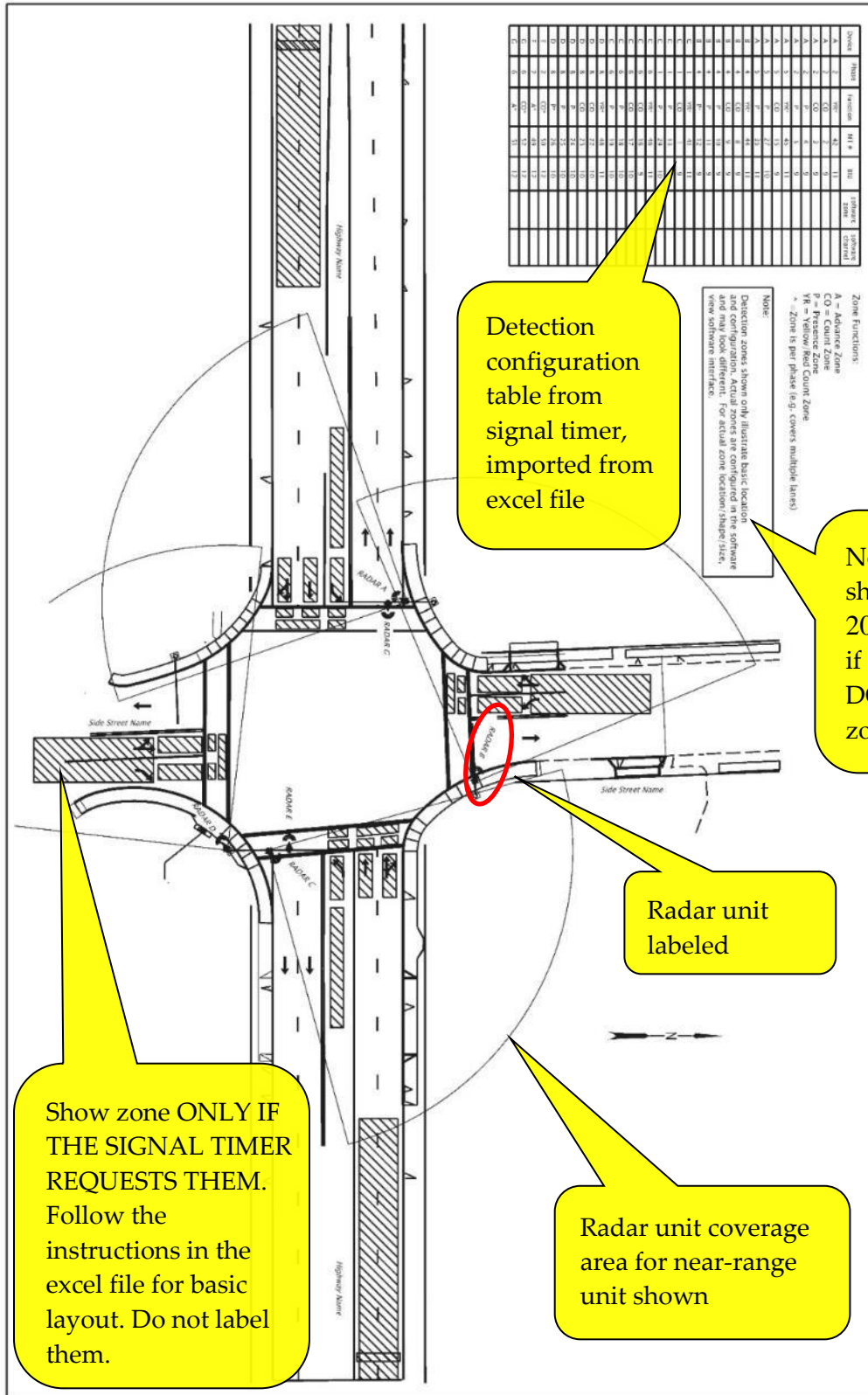

Figure 20-37 | 332S Cabinet Print (Page 7 – Detection Drawing) Example 2





## **20.12 332S Cabinet Print (Page 8 – Railroad Preemption Plan Sheet)**

Page 8 is only included for traffic signals that are interconnected to a railroad crossing. Page 8 of the cabinet print is NOT contained within the microstation cabinet print file as described in section 20.4. It will instead be a separate PDF page of the sealed and approved railroad preemption plan sheet that is required as per chapter 16 for the crossing order. Combine the cabinet print PDF (pages 1 through 7) with the sealed and approved railroad preemption plan sheet PDF (page 8) via adobe. See

Figure 20-38. Combining the sealed and approved railroad preemption plan sheet PDF to the cabinet print PDF incorrectly will result in breaking the digital signatures and show up as a blank spot. To avoid this, the following process should be used:

1. Open the PDF of the sealed railroad preemption plan sheet, the digital signature should be visible and can also be verified.
2. Go to “print” and set the printer to “Microsoft print to PDF” to make a copy and save the new PDF file. The signature should still be visible in the new file, but it is no longer an actual digital signature (it is basically a photocopy of the digital signature).
3. The new PDF file can now be combined with the cabinet print PDF into a single electronic document.

The railroad preemption plan sheet is required to be sealed and approved, so if any changes are needed to it in the future, follow the process and guidance described in chapter 16. Updating the railroad preemption plan sheet for the cabinet print may or may not require a rail crossing order (e.g., also documenting the updated preemption plan sheet in a crossing order) as per the decision by the ODOT commerce and compliance division. Contact the state traffic signal engineer for assistance in getting this process started.

Figure 20-38 | 332S Cabinet Print (Page 8 – Railroad Preemption Plan Sheet) Example

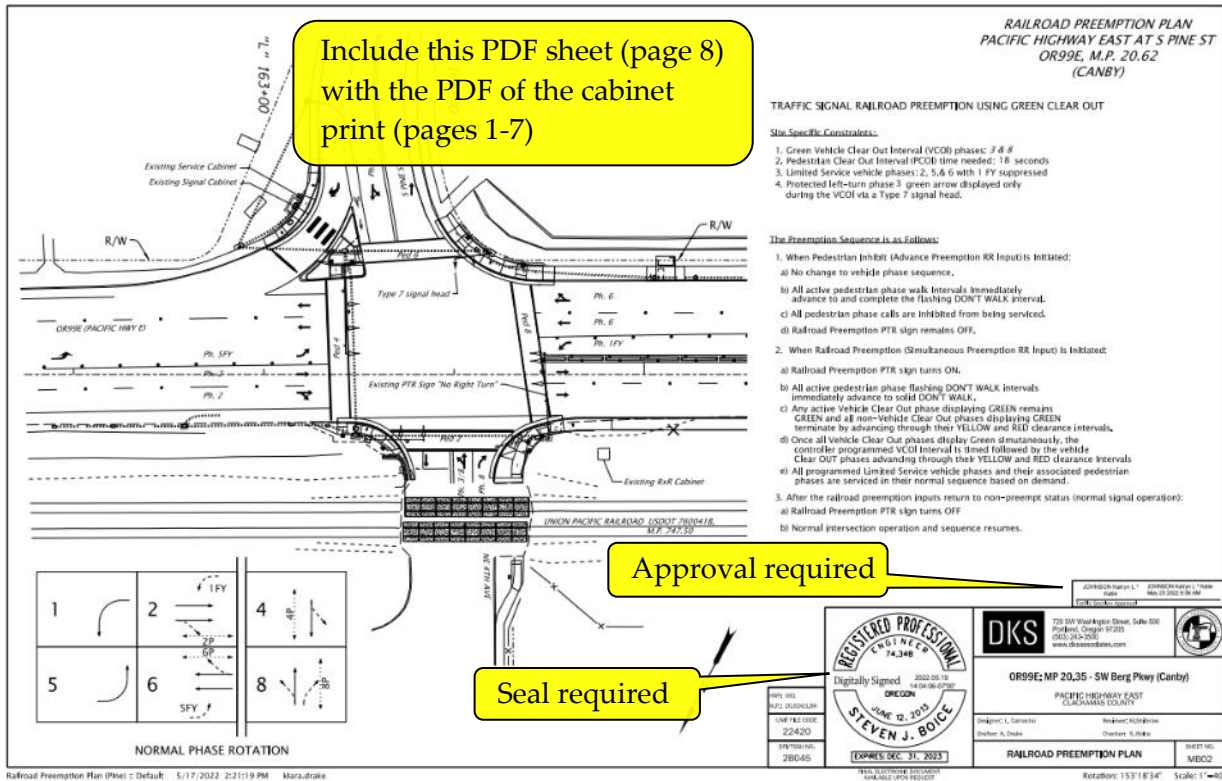

The railroad preemption plan sheet provides important information that signal timers, TSSU, and electricians should know for properly maintaining and operating the traffic signal. It is also helpful for the signal designer to use when completing the cabinet print. The following is a list of rail interconnected specific items to remember to detail in the cabinet print:

- Type 7 signal head – show a load switch in the appropriate location in the output file and label it “RxR grm clear-out only”
- Include the type 7 signal head phase in the conflict monitor diode information as per Figure 20-27
- PTR signs – show a load switch in the appropriate location in the aux. output file and label it “RxR PTR”
- Include the AC isolator in the appropriate location in the input file (252 model for 332 cabinets and 255 model for 332s cabinets)

## 20.13 Background/Reference Information

This section contains more in-depth information to aid in understanding guidance presented in this chapter.

### 20.13.1 Flashing Yellow Arrow and Conflict Monitoring

Two problems with using pedestrian yellow outputs for FYA were identified when troubleshooting several signals that went into cabinet flash after installing negative ped overlap phases and/or type 3LCF signal heads. The results of this investigation led to changing the FYA output and conflict monitoring standard from ped yellow with yellow inhibit jumpers to overlap green (ch. 9 thru 12).

**Problem 1:** Using a ped yellow output for the FYA will not work if the FYA has different conflicts than the ped walk. For example, Figure 20-39 shows that OLC is not compatible with ped 6 which would require conflict monitor diode 11-15 to remain intact. However, OLC is compatible with ph. 5 FYA which would require conflict monitor diode 11-15 to be removed. If diode 11-15 remains intact, the signal will go into cabinet flash when OLC and phase 5 FYA are served together, resulting in signal phasing that will fail every cycle. If diode 11-5 is removed, the signal will NOT go into cabinet flash if OLC and ped 6 are served together, resulting in unsafe operation.

Figure 20-39 | Problem 1: FYA and WALK phase have different conflicts

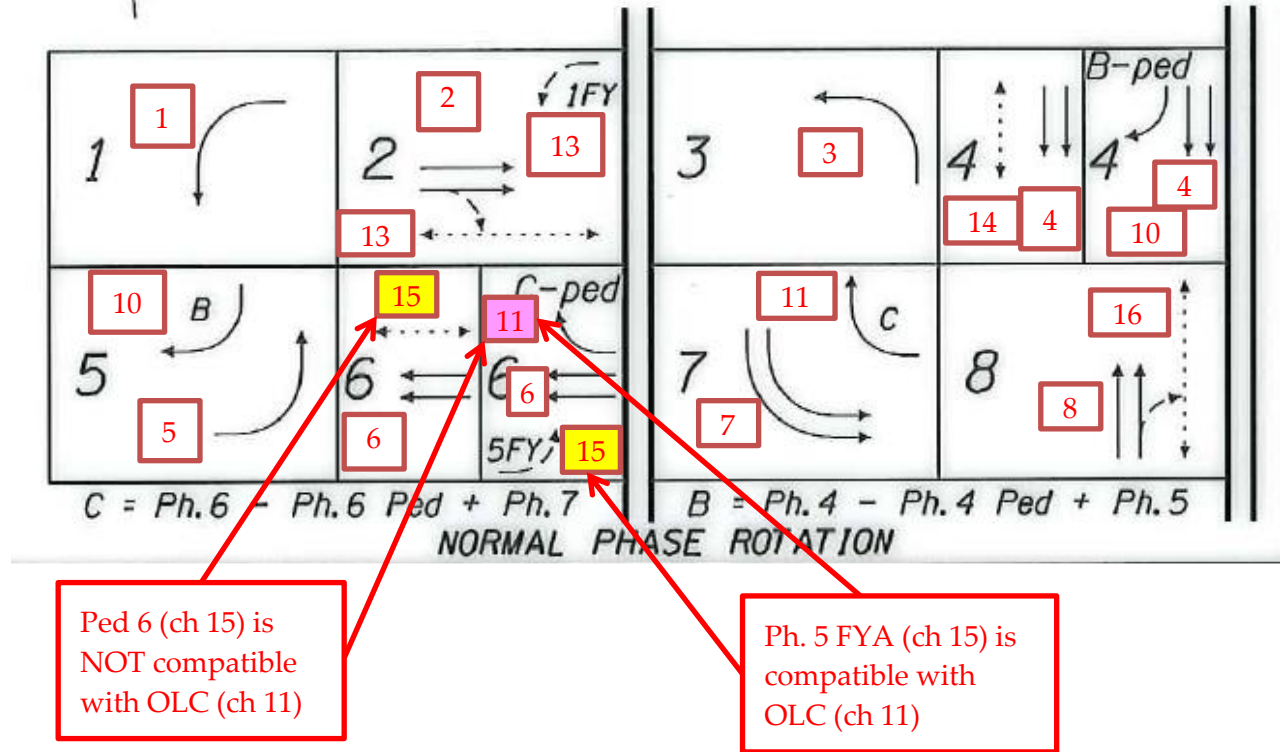

CONFLICT MONITOR DIODE CARD

CHANNEL ASSIGNMENT

Ch.1 <u>Ph. 1</u>	Ch.5 <u>Ph. 5</u>	Ch.9 _____	Ch.13 <u>Ped2/1FYA</u>
Ch.2 <u>Ph. 2</u>	Ch.6 <u>Ph. 6</u>	Ch.10 <u>OLB</u>	Ch.14 <u>Ped4</u>
Ch.3 <u>Ph. 3</u>	Ch.7 <u>Ph. 7</u>	Ch.11 <u>OLC</u>	Ch.15 <u>Ped6/5FYA</u>
Ch.4 <u>Ph. 4</u>	Ch.8 <u>Ph. 8</u>	Ch.12 _____	Ch.16 <u>Ped8</u>

YELLOW INHIBIT JUMPERS

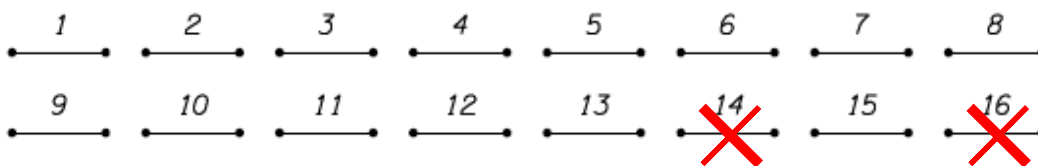

**Problem 2:** Using a ped yellow output for the FYA will not work with a type 3LCF signal head and overlap phase. The type 3LCF signal head uses only one wire terminated at the yellow indication which will provide both the solid yellow and the flashing yellow function. The solid yellow will be monitored because the FYA is required to be monitored and both functions are driven by the same wire/output in the controller cabinet. The solid yellow has different conflicts than the FYA which will cause the signal to go into cabinet flash when the complementary overlap phase stays green while the protected left turn phase is solid yellow. For example, Figure 20-40 shows the conflict monitor channel assignment and Figure 20-41 shows where this phasing sequence creates a conflict monitoring problem with the solid yellow and overlap phase.

Figure 20-40 | Problem 2: FYA and solid yellow have different conflicts – Conflict monitor channel assignment

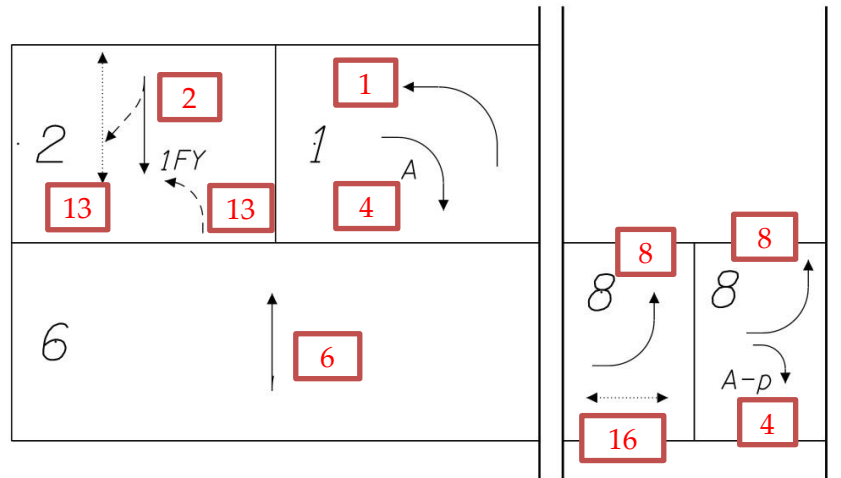

OLA = Ph. 1 & Ph. 8 - Ped 8

NORMAL PHASE ROTATION

CONFLICT MONITOR DIODE CARD

CHANNEL ASSIGNMENT

Ch.1 <b>Ph. 1</b>	Ch.5 _____	Ch.9 _____	Ch.13 <b>Ped2/1FYA</b>
Ch.2 <b>Ph. 2</b>	Ch.6 <b>Ph. 6</b>	Ch.10 _____	Ch.14 _____
Ch.3 _____	Ch.7 _____	Ch.11 _____	Ch.15 _____
Ch.4 <b>OLA</b>	Ch.8 <b>Ph. 8</b>	Ch.12 _____	Ch.16 <b>Ped8</b>

YELLOW INHIBIT JUMPERS

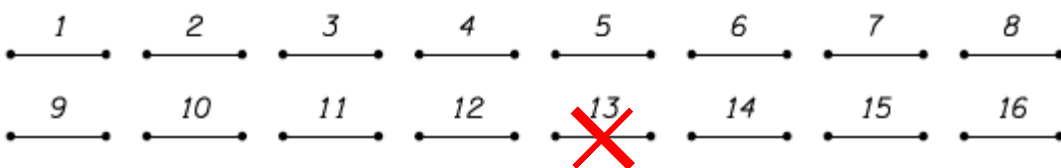
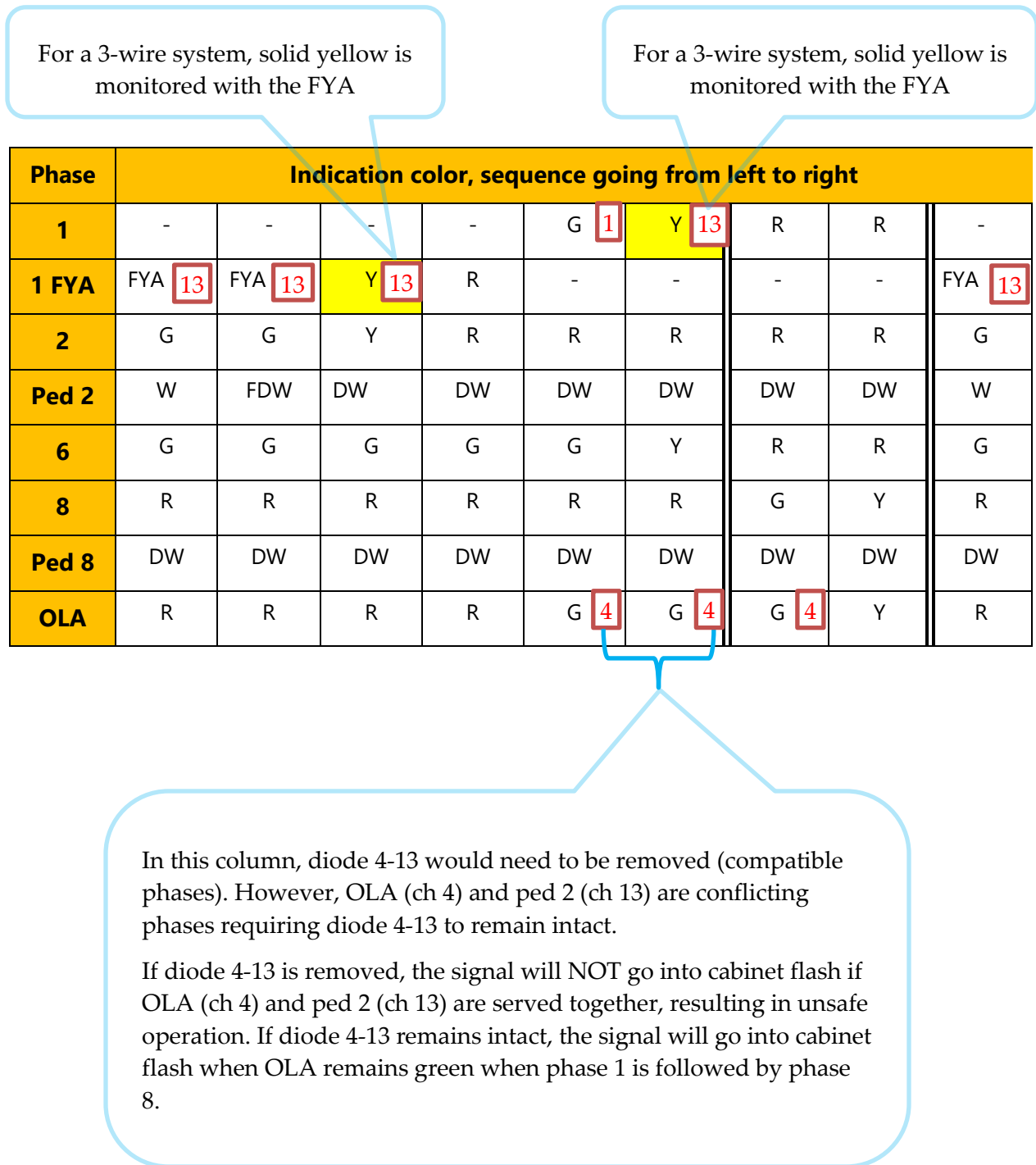

Figure 20-41 | Problem 2: FYA and solid yellow have different conflicts – phasing sequence





Various solutions to these two problems, listed below, were thoroughly vetted by traffic engineering section, TSSU, region traffic and local agency staff:

- **Do not monitor the flashing yellow arrow:** Several local agencies do not monitor the flashing yellow arrow because the software controlling the flashing yellow arrow sequence has a high level of reliability and there are a limited number of conflicts that can be monitored using the standard conflict monitoring equipment. On the same principle, ODOT does not monitor the flashing don't walk portion of the pedestrian phase (only the walk phase is monitored). However, ODOT has a long standing history of requiring monitoring of the flashing yellow arrow as it provides the same function as a circular green indication for a permissive left turn and we monitor all green indications. At this point in time, this option was dismissed due to the importance of ensuring the flashing yellow arrow does not run concurrent to any conflicting phase.
- **Restrict signal phasing options:** Allow the overlap phase and remove the FYA or allow the FYA and remove the overlap phase. One of the original benefits of the standard conflict monitoring using pedestrian yellow outputs for FYA was to “free-up” the overlap channels (ch 9 thru 12) for use. In the past, when overlap phases used type 2 programmed signal heads or closed conflicting pedestrian crossings, those “available” channels could be used without a conflict monitoring problem. This changed when overlap phases started to use type 3R signal heads and negative ped phasing, basically making those previously “available” overlap channels unusable if pedestrian yellow outputs were being used for FYA. Restricting the desired operation at the intersection was also met with widely varying opinions about what phases are truly needed. This option was dismissed because agreement could not be reached that prioritizing the conflict monitoring standard (ped yellow FYA monitoring) over desired operations (when operational analysis indicates certain phases are not needed for acceptable V/C and queue lengths) was a viable solution and an original benefit of using ped yellow monitoring was negated.
- **Problem 2 only – use a type 6L signal head (separate wire and termination for solid yellow and flashing yellow):** This option allows the solid yellow indication to be unmonitored. This option was dismissed because ODOT is moving away from using type 6L signal heads for new PPLT installations. The type 3LCF signal head has many advantages over the type 6L signal head, such as reduced structural loading, less wiring, reducing the number of signal head types for maintenance to stock, and far easier ability to retro-fit existing installations.
- **Problem 2 only - Restrict signal phasing to ensure overlap phase green and solid yellow are never served together:** By restricting the sequencing of the left turn phase (lead/lag) and recalling other phases, the solid yellow and overlap green will always terminate at the same time. See Figure 20-42 for example. This option was dismissed due to being overly complicated to determine the correct sequencing and because changing from a left turn phase from leading to lagging shouldn't require a change to the conflict monitor.

Figure 20-42 | Problem 2 potential solution: Restricted signal phasing sequence

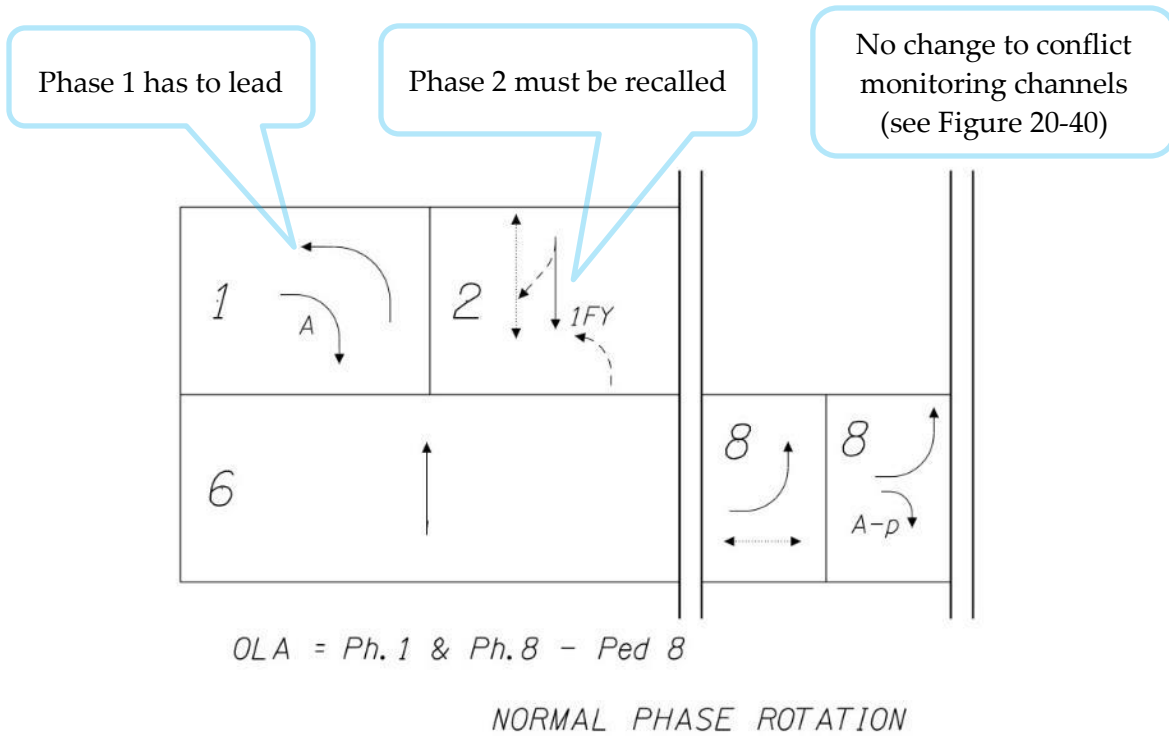

Phase	Indication color, sequence going from left to right									
<b>1</b>	G <b>1</b>	Y <b>13</b>	R	-	-	-	-	-	-	G <b>1</b>
<b>1 FYA</b>	-	-	-	FYA <b>13</b>	Y <b>13</b>	R	R	R	R	-
<b>2</b>	R	R	G	G	Y	R	R	R	R	R
<b>Ped 2</b>	DW	DW	W <b>13</b>	FDW	DW	DW	DW	DW	DW	DW
<b>6</b>	G	G	G	G	Y	R	R	R	R	G
<b>8</b>	R	R	R	R	R	G	G	G	Y	R
<b>Ped 8</b>	DW	DW	DW	DW	DW	W	FDW	DW	DW	DW
<b>OLA</b>	G <b>4</b>	Y	R	R	R	R	R	G <b>4</b>	G <b>4</b>	G <b>4</b>

Phase 1 solid yellow will never be on with OLA green because phase 1 is always followed by phase 2, which will terminate OLA green and phase 1 green at the same time.

Phase 1 solid yellow will never be on with OLA green