

Chapter 13

Contents

13 Ramp Meters 13-1

13.1 Ramp Meter Operation 13-1

 13.1.1 Location of the Ramp Meter Stop Line 13-1

13.2 Ramp Meter Signal Indication Mounting 13-2

 13.2.1 Ramp Meter Signal Assembly (Pedestal) 13-4

 13.2.2 Overhead Mounted (Mast Arm) 13-7

 13.2.3 Ramp Meter Phasing 13-9

13.3 Ramp Meter Signs 13-10

 13.3.1 Ramp Metered When Flashing Sign (With Flashing Yellow Beacon) 13-10

 13.3.2 Form 2 Lanes When Metered Sign 13-11

 13.3.3 Stop Here on Red Sign 13-11

 13.3.4 One Vehicle Per Green Sign 13-11

 13.3.5 Coordinating Sign Placement on Ramp 13-11

13.4 Ramp Meter Striping 13-14

13.5 Ramp Meter Cabinets and Controllers 13-14

13.6 Ramp Meter Detection 13-15

 13.6.1 Detector Functions, Location, and Placement 13-15

 13.6.2 334 Controller Cabinet Input Detection File 13-19

 13.6.3 Detector Wiring Diagram 13-19

13.7 Wiring 13-19

13.8 Background/Reference Information 13-20

 13.8.1 Queue Detection History 13-20

 13.8.2 PTR sign History 13-21

13 Ramp Meters

This chapter discusses only ramp meter specific design information. Other general information that also may also pertain to ramp meters (e.g., signal wiring, detection, etc.) can be found in the previous chapters of this manual.

Installation of a new ramp meter or modification of an existing ramp meter requires region traffic engineer operational approval as per chapter 3.

13.1 Ramp Meter Operation

Ramp meters are used to control the frequency of traffic entering a highway facility. By controlling the rate of vehicles entering the highway, the traffic flow on the highway facility becomes more consistent and allows for more efficient use of existing highway capacity. They are programmed to release one vehicle at a time. Just prior to activating, the ramp meter indications will flash yellow (from the yellow indication of the type 2 signal head) for a short, predetermined amount of time to warn traffic that the ramp meter is starting up. The ramp meter will then display a solid yellow interval followed by an all red interval prior to the start of the normal red-green alternating ramp meter cycle.

For ramp meters that control two or more lanes of traffic, each indication for each lane must operate on a separate phase to properly alternate the red-green phase between each lane.

Ramp meters remain dark when not in use.

13.1.1 Location of the Ramp Meter Stop Line

The location of the ramp meter stop line is determined by engineering judgment. Each ramp alignment is unique, and the site specifics play a major role in determining the most appropriate location. The basic goal is to place the stop line far enough down the ramp to provide reasonable storage of vehicles but not so near the highway that acceleration and merging onto the highway becomes a problem. Some things to consider determining the most appropriate location:

- Design hour queue length: The operational analysis and RTE operational approval will determine the required length for storage.
- Ramp alignment length (from ramp entrance to the painted gore point): the ramp alignment length should accommodate the design hour queue length if possible.
- Number of lanes controlled by the ramp meter: the number of lanes needed will be addressed in the operation analysis and RTE operational approval. This will directly affect the required queue length. Single and dual lane ramp meters are common.
- The vertical grade: a downhill vertical grade will allow the stop line to be placed closer to the highway, while an uphill vertical grade will require additional space between the stop line and the merge point.

- The length of acceleration lane (from painted gore point to the downstream acceleration lane taper point): a standard length acceleration lane will allow the stop line to be placed closer to the highway, while a substandard length acceleration lane may require additional space between the stop line and the merge point.
- Sight distance from stop line to the highway: the location where vehicles stop should have adequate sight distance to the highway to help facilitate a safe and efficient merge.
- Percentage of truck traffic using the ramp: trucks require more distance to come up to speed and may require additional space between the stop line and the merge point.

Work with region traffic and the roadway designer when determining the appropriate location.

13.2 Ramp Meter Signal Indication Mounting

There are two choices for mounting ramp meter signal indications: on a pedestal or overhead (mast arm). The pedestal mount is used unless there is a specific reason that requires an overhead mount, such as:

- The ramp meter will control more than 2 lanes of traffic. See Figure 13-1 for an example.
- The ramp meter will control 2 lanes of traffic with the stop line located beyond the physical gore point of ramp. See Figure 13-2 for an example.
- Physical constraints prevent proper location of pedestal(s), such as: retaining walls, bridges, barrier, sound walls, etc.). See Figure 13-3 for an example.

Figure 13-1 | Ramp Meter Controls More Than 2 lanes of Traffic – Requires Overhead Mount



Figure 13-2 | Ramp Meter Controls 2 Lanes of Traffic with Stop Line Located Beyond Physical Gore Point – Requires Overhead Mount



Figure 13-3 | Physical Constraints (Barrier on Left Side) - Requires Overhead Mount



13.2.1 Ramp Meter Signal Assembly (Pedestal)

The ramp meter signal assembly is mounted on pedestal (foundation number 3) and includes the following four traffic control devices as per standard drawing TM492 (listed from top to bottom of pedestal): a type 2 vehicle signal head, a “STOP HERE ON RED” aluminum sign, a type 8 vehicle signal head, and a “ONE VEHICLE PER GREEN” aluminum sign. A near-range radar detector unit is also typically mounted at the top (one detector unit for the stop location). See Figure 13-4.

Figure 13-4 | Ramp Meter Signal Assembly TM492 (Pedestal)

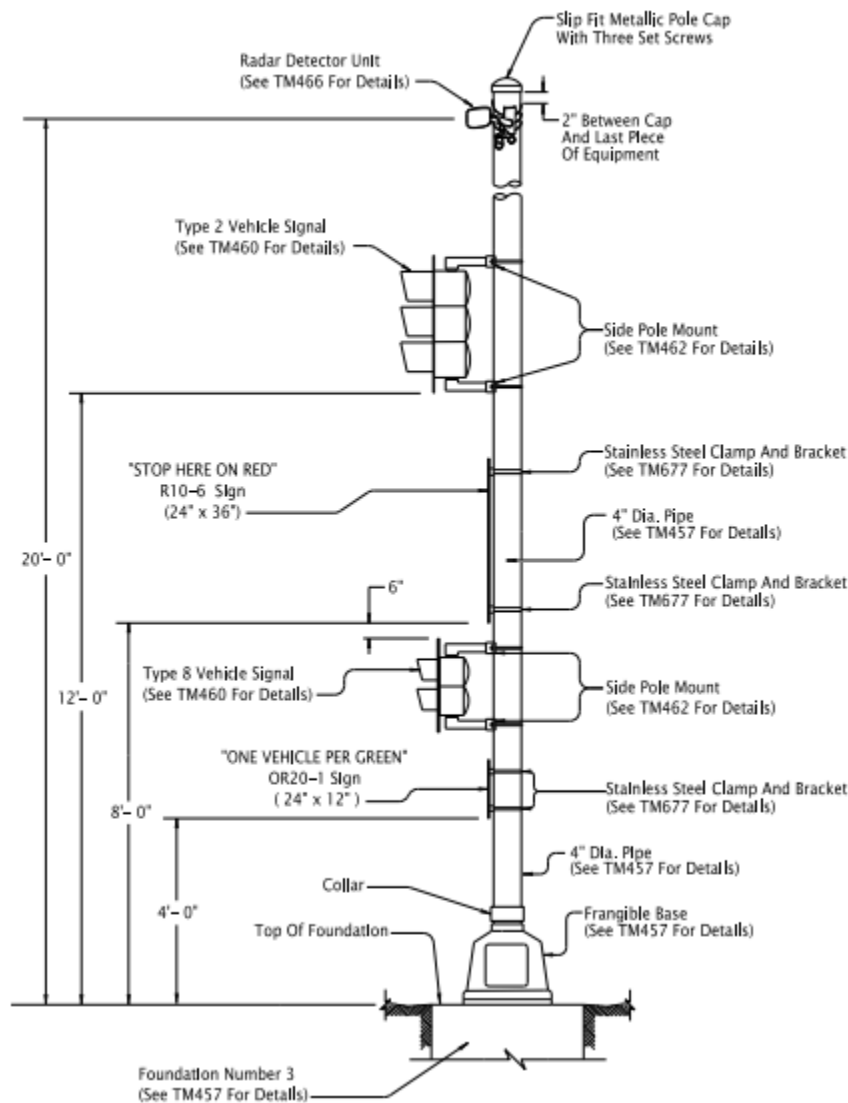

Traffic Signal Design Manual – Ramp Meters

For a ramp meter that will control a single lane of traffic, this pedestal assembly is required only on the right side for a ramp. See Figure 13-5. For a ramp meter that will control two lanes of traffic, this pedestal assembly is required on both the sides of the ramp. See Figure 13-6.

Figure 13-5 |Ramp Meter Signal Assembly Example – Controlling a Single Lane of Traffic



Figure 13-6 |Ramp Meter Signal Assembly Example – Controlling Two Lanes of Traffic



Traffic Signal Design Manual – Ramp Meters

The ramp meter signal assembly is placed 25 feet from the stop line location. Lateral placement on the right side of the ramp is 10 feet from the edge of pavement to allow for placement of a detector unit. Lateral placement on the left side of the ramp is 5 feet minimum from both edges of pavement. See Figure 13-7.

Figure 13-7 | Location of Ramp Meter Signal Assembly from the Stop Line

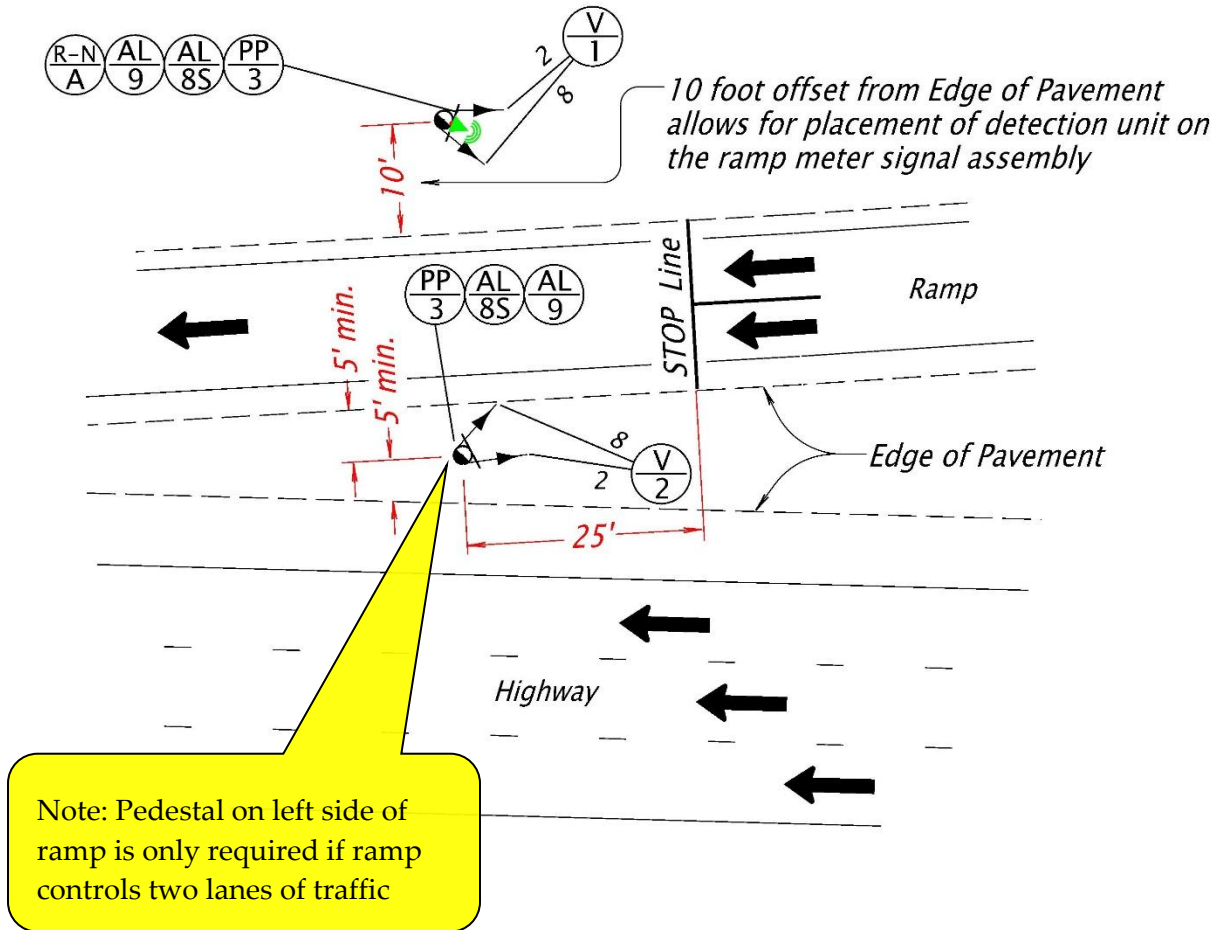

13.2.2 Overhead Mounted (Mast Arm)

Overhead mounted ramp meter signals require a type 2 vehicle signal head and an aluminum “ONE VEHICLE PER GREEN” sign for each lane that is controlled by the ramp meter. The “ONE VEHICLE PER GREEN” sign used overhead is 24”x30”. Type 8 heads are NOT used when indications are mounted overhead. The overhead signal indications are located 55 feet from the stop line. The mast arm pole should be 10 feet from the edge of pavement to allow for placement of the detection unit on the mast arm or pole. Two aluminum “STOP HERE ON RED” signs are located at the stop line, one on each side of the ramp (these signs are standard ground mounted signs that are shown and detailed on the sign plan sheets). See Figure 13-8 and Figure 13-9 for an example.

Figure 13-8 | Overhead Mounted Details

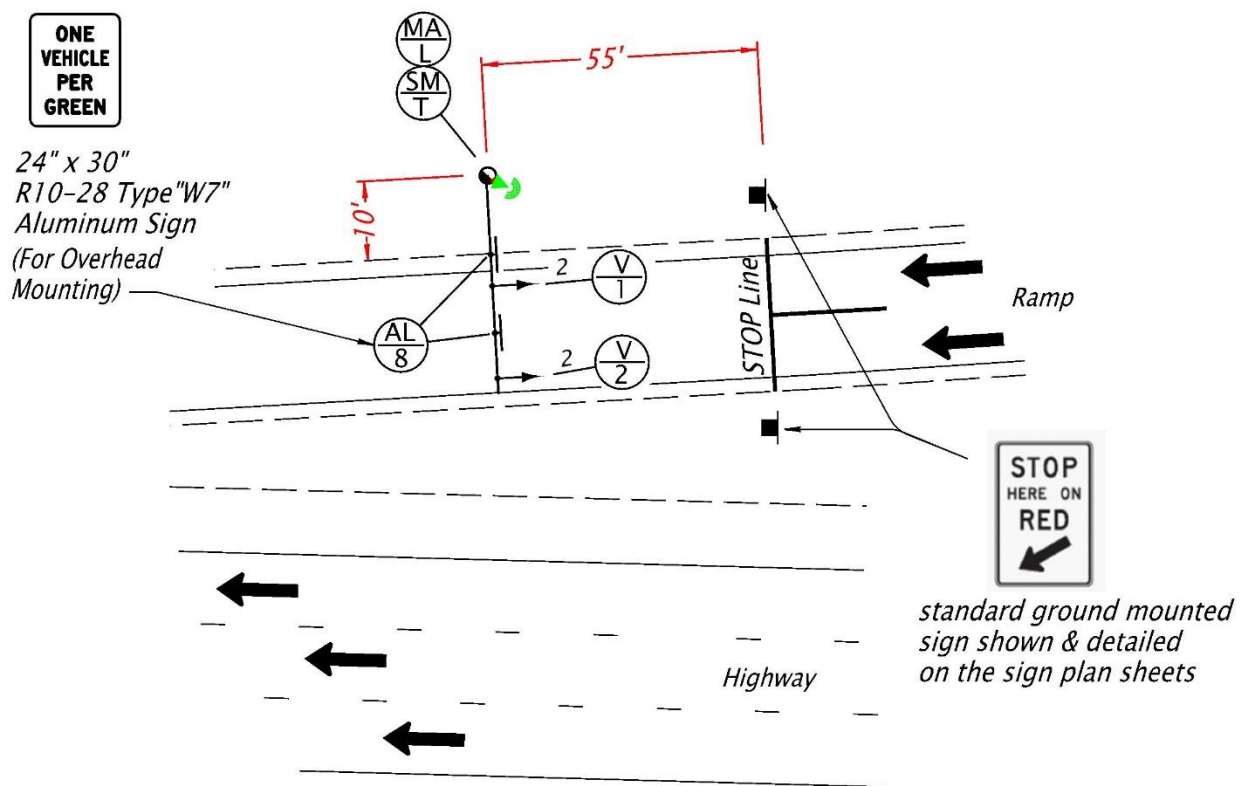

Figure 13-9 | Overhead Mounting Example



13.2.3 Ramp Meter Phasing

Each lane controlled by the ramp meter will be assigned a unique phase, starting with phase 1. When two (or more) lanes are controlled by the ramp meter, phase 1 is always the outermost lane of the ramp, which each adjacent lane towards the highway being assigned the next consecutive phase. See Figure 13-10.

Figure 13-10 | Ramp Meter Phasing

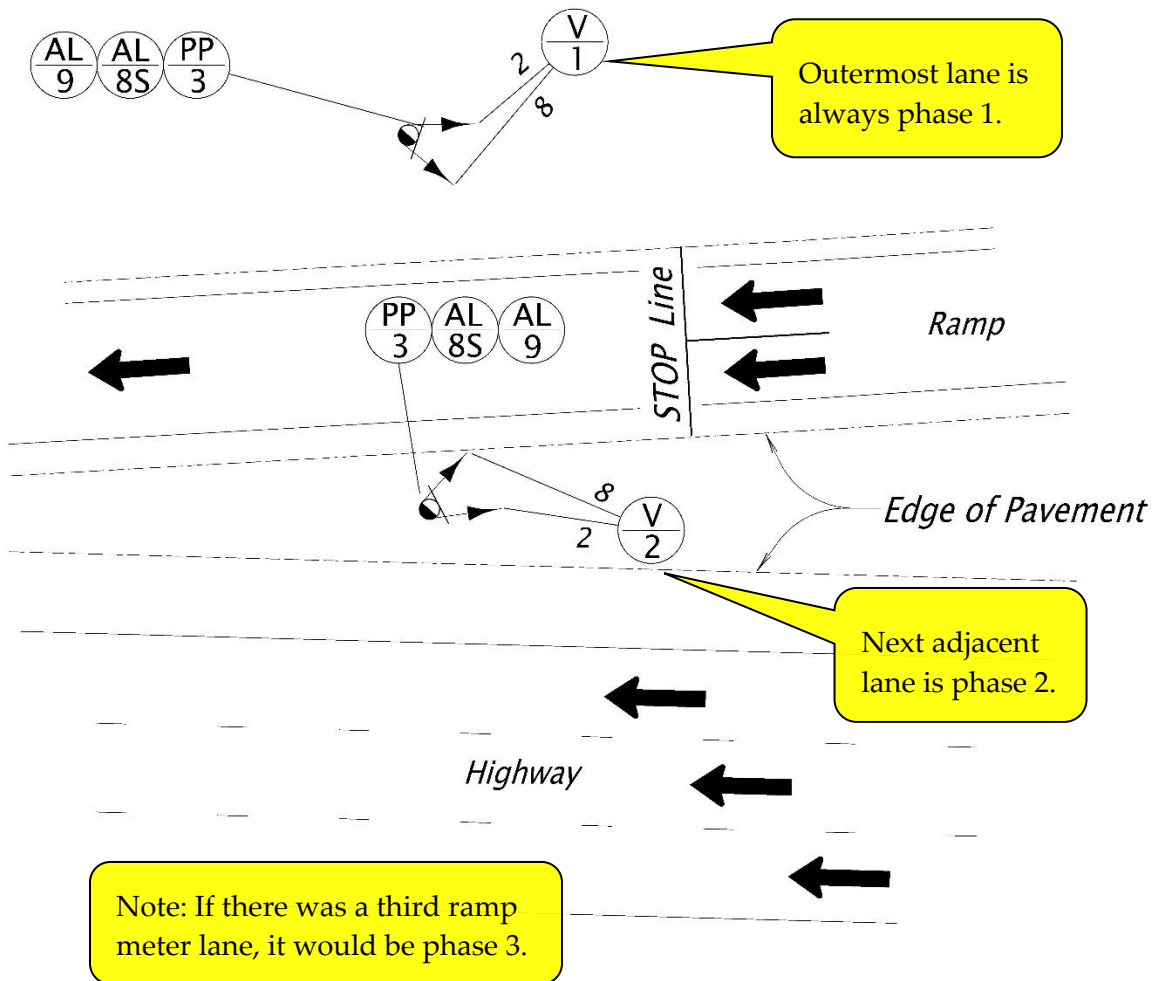

13.3 Ramp Meter Signs

The standard layout for ramp meter signing is discussed and shown in the following sections. See Figure 13-11 for ramp meter signal assemblies and Figure 13-12 for overhead mounted ramp meters.

13.3.1 Ramp Metered When Flashing Sign (With Flashing Yellow Beacon)

This sign is required for all ramp meter installations. It is located at the entrance to the ramp, and it should be visible to each legal move that enters the ramp. This may require more than one sign depending on the ramp terminal geometry. The main purpose of this sign is to provide advance warning that the ramp meter is operating, and drivers should be prepared to stop as they proceed down the ramp. Depending on the ramp configuration and ramp terminal geometry/lane use, it also can provide information before the driver commits to entering the ramp, allowing the driver to seek an alternate route if desired. However, use of this sign to make a decision on an alternate route is not a critical message the following reasons:

- There may not be a viable alternate route in the immediate vicinity after seeing the sign.
- At the majority of ramp configurations, the driver must commit to making the movement onto the ramp well in advance of the ramp entrance when these signs aren't yet visible (typically getting into a right or left turn only lane at an intersection or just proceeding on a roadway that ends as a ramp merging onto the highway).
- Many drivers use modern navigation systems that can provide excellent directions and alternate routes based on real-time traffic data. This allows drivers to plan their routes better and have advance notice of traffic congestion.

The standard placement of this sign (at the entrance of the ramp) should provide adequate advance warning of the ramp meter operation at the majority of ramps, even when the visibility to the ramp meter indications does not meet minimum MUTCD requirements. However, this sign may also be used further down the ramp if an engineering study deems an additional supplemental warning sign is necessary due to a unique ramp geometry (e.g., a very long ramp with multiple curves). If used as a supplemental warning, two signs are required (one on each side of the ramp) and they should be located upstream from the anticipated queue length. The need for these supplemental signs will be documented in the RTE operational approval.

This sign is mounted on a pedestal as per standard drawing TM492. It is detailed on the ramp meter plan sheet and paid for under the ramp meter lump sum bid item.

13.3.2 Form 2 Lanes When Metered Sign

This sign is required only for single lane ramps with ramp meters that control two lanes of traffic. It is located upstream from the anticipated queue length. Two signs are required, one on each side of the ramp.

This sign is mounted on an appropriate standard sign support (e.g., wood post or square tube sign support). It is detailed on the signing plan sheet (NOT on the ramp meter plan sheet) and is measured and paid for under the applicable sign and post bid items.

13.3.3 Stop Here on Red Sign

This sign is required at the stop line. If the ramp meter only controls one lane of traffic, only one of these signs is required, preferably with the ramp meter assembly on the right side of the ramp. For all other applications, two of signs are required, one on each side of the ramp.

For ground mounted installations, this sign is part of the standard ramp meter signal assembly which is detailed on the ramp meter plan sheet and paid for under the ramp meter lump sum bid item.

For overhead mounted ramp meters, this sign is ground mounted at the stop line on an appropriate standard sign support (e.g., wood post or square tube sign support) which is detailed on the signing plan sheet (NOT on the ramp meter plan sheet) and is measured and paid for under the applicable sign and post bid items.

13.3.4 One Vehicle Per Green Sign

This sign is required for all installations, one for each lane of traffic controlled by the ramp meter.

For ground mounted ramp meter installations, this sign is a part of the standard ramp meter signal assembly. For overhead mounted ramp meters this sign is installed with an adjustable sign bracket adjacent to each signal indication. Note the ground mounted sign is a smaller in size than the overhead sign (making it a different sign number). In both cases, it is detailed on the ramp meter plan sheet and paid for under the ramp meter lump sum bid item.

13.3.5 Coordinating Sign Placement on Ramp

Other signs on the ramp (e.g., merge, lane transition, curve w/advisory speed, etc.) will need to be taken into consideration when locating the signs and equipment specific to the ramp meter. Work with the sign designer to coordinate the locations of all traffic control devices needed on the ramp.

Figure 13-11 | Ramp Meter Sign Layout – Ramp Meter Signal Assemblies

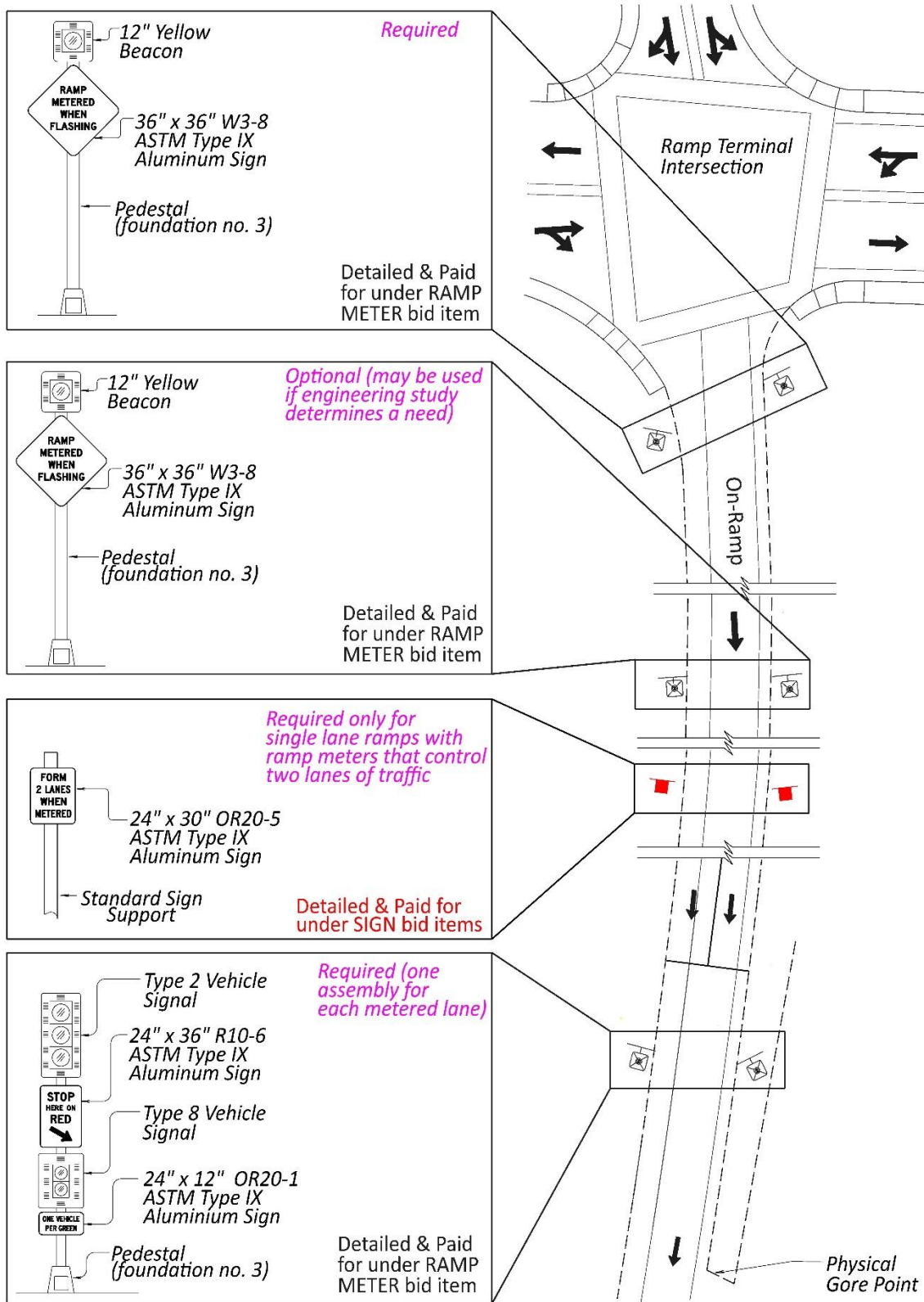
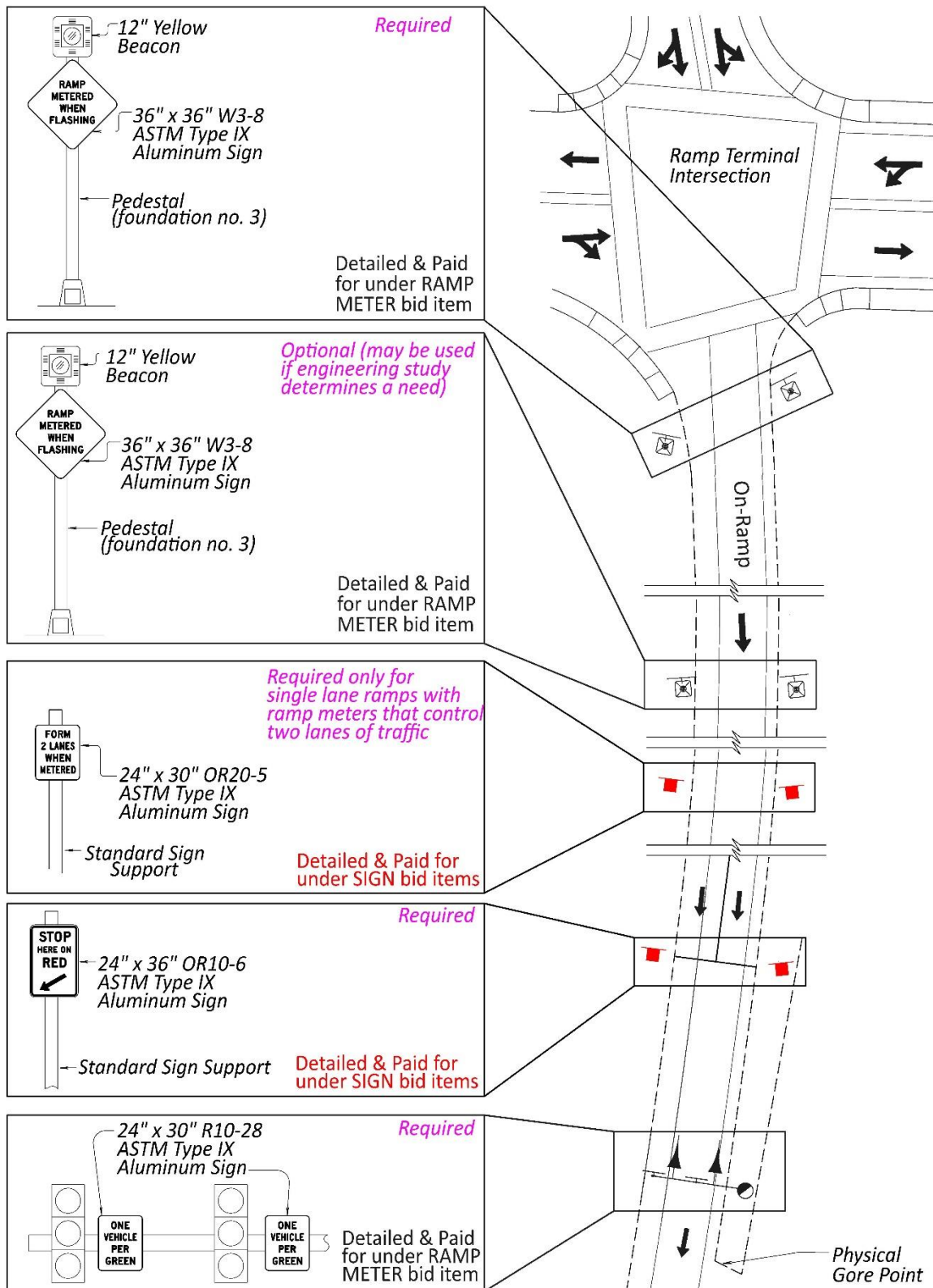

Figure 13-12 | Ramp Meter Sign Layout – Overhead Mounted Ramp Meter Assemblies



13.4 Ramp Meter Striping

The ramp meter requires a stop line. For single lane ramps with a ramp meter that controls two lanes, an 8-inch wide white line is extended back from the stop line as per standard drawing TM503, detail “S-RM”. See Figure 13-13.

Ramp meter striping is detailed on the striping plans and paid for under the striping bid items. Work with the striping designer.

Figure 13-13 | Ramp Meter Striping (TM503)

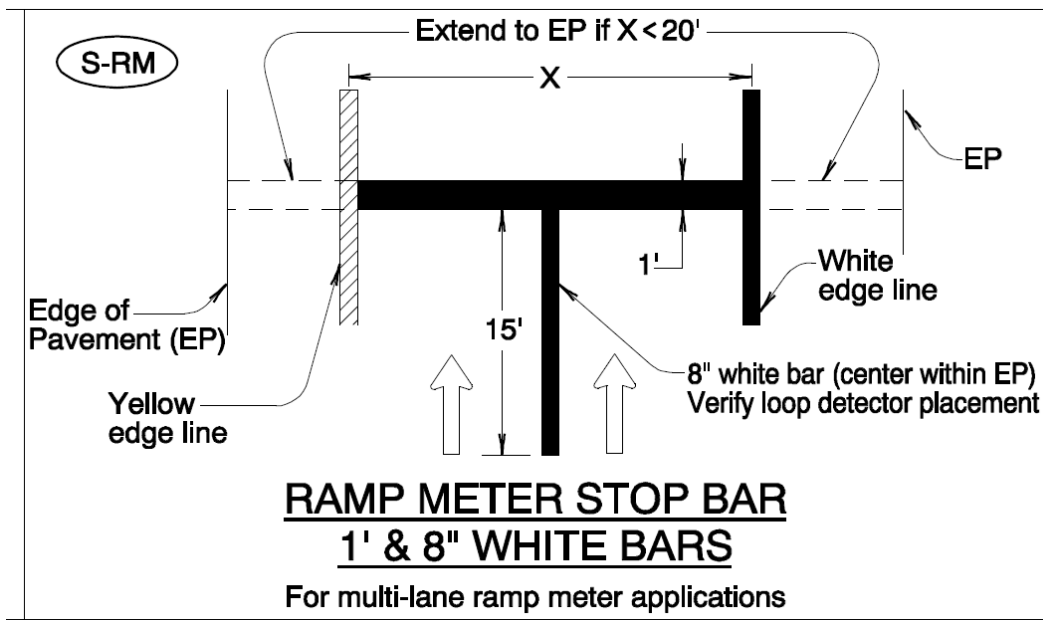

13.5 Ramp Meter Cabinets and Controllers

Ramp metering devices are controlled by an ATC controller in a model 334 ground-mounted controller cabinet. The ATC controllers are agency supplied and purchased by the agency through a price agreement managed by ITS.

The service cabinet for ramp meters is the standard base mounted service cabinet (BMC) that is also used for traffic signals.

The controller cabinet and service cabinet should be located near the ramp meter signal indications for ease of maintenance and operational convenience. Include a maintenance landing pad for maintenance vehicle access near the controller (see standard drawing RD160).

13.6 Ramp Meter Detection

Radar detection is the standard form of detection for ramp meters. This section provides ramp meter detection specific information. Refer to chapter 6 for more general information related to detection.

13.6.1 Detector Functions, Location, and Placement

Ramp meter detection serves three different functions as described below. Queue detection is no longer used.

- **Demand:** This type of detection is approximately 15 feet long and located at the stop line. It is used to place a call into the controller to bring up the green phase of the ramp meter cycle.
- **Passage:** This type of detection is a small zone located 15 feet downstream from the stop line. It is used count ramp meter traffic, perform truck extension, and violation extension.
- **Count:** This type of detection is located on the freeway main line. Typically this detection is installed just downstream of where the on-ramp merges onto the highway, but the exact location on the freeway is determined by region traffic and the ITS unit.

Near-range radar units are used for demand and passage detection zones. See Figure 13-14 and Figure 13-15 for an illustration of the detection zones and placement of the radar detector unit (either on the ramp meter signal assembly or on the mast arm). The signal designer is responsible for detailing the demand and passage detection system on the ramp meter plans.

Side fire radar units are used for count detection zones. See Figure 13-16 for an illustration of the count detection zones and general placement of the side-fire detection unit. Coordinate with both region traffic and the ITS unit for determining the count detection location, necessary equipment, and responsibility for design work. There are two options for providing the count detection (note that the side fire radar unit will become an ITS asset regardless of which option is chosen, so coordination with the ITS unit is always required):

- Count detection provided via a stand-alone ITS count site (with ITS controller cabinet), separate from the ramp meter controller cabinet: This is the typical arrangement in region 1 with the ITS count site often co-located with PTZ cameras. In this case the ITS designer is responsible for detailing the entire count detection system on ITS plan sheets. If the ITS unit does not provide an ITS designer for the project, the signal designer may produce the ITS plan sheets, under the direction of the ITS unit using their unpublished design aids.
- Count detection provided via the ramp meter controller cabinet: If the count detection will be provided by the ramp meter controller cabinet, the signal designer is responsible for detailing the entire count detection system on the ramp meter plan sheets.

Mounting radar detector units to stand-alone pedestals or poles may be necessary to get the

desired detection zone coverage. If a pedestal will not provide the proper mounting height (as per the manufacturer requirements), the ITS unit has some details for fiberglass poles that may be used instead. Contact the ITS unit for these details. Mounting detector units on luminaire poles is also a possibility if the power for the detector unit and the illumination comes from the same service cabinet.

Verify maintenance access to each radar unit with the electrical crew. Evaluating the cross-section slopes, available shoulder, detector unit mounting heights, and bucket truck/ladder limitations is critical to safely maintaining a ramp meter installation, both for the public and the maintainer. If a location does not meet the needs for maintenance, the following solutions should be considered:

- A maintenance landing pad (see standard drawing RD160)
- Flattening a slope
- Widening a shoulder
- Alternative device location

Note: The ITS unit has a price agreement for certain radar units. If radar devices are installed on a project, ALL radar devices on the project need to be consistent. Either ALL are Agency supplied (using the price agreement and adding "(Agency supplied)" to the appropriate bubble notes), or ALL are supplied by the contractor (using the standard bubble notes). **Contact the ITS standards engineer to notify and coordinate using the radar price agreement on a project.**

Figure 13-14 | Demand & Passage Detection Layout, Detector Unit Mounted on Pedestal

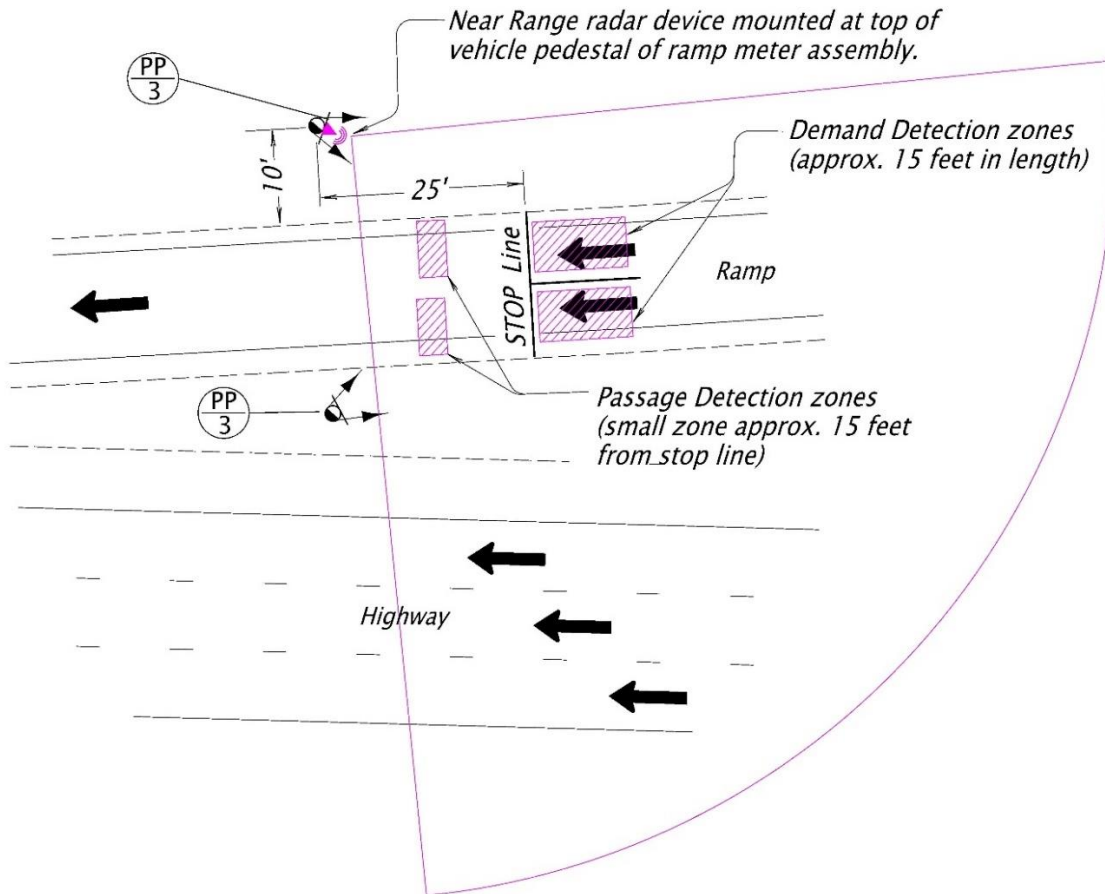

NOTE: If pedestal cannot be placed as shown with respect to the stop line and edge of pavement, the detection unit should be mounted on a stand-alone pedestal or pole that can provide proper coverage for the detection zones.

Figure 13-15 | Demand & Passage Detection Layout, Detector Unit Mounted on Mast Arm

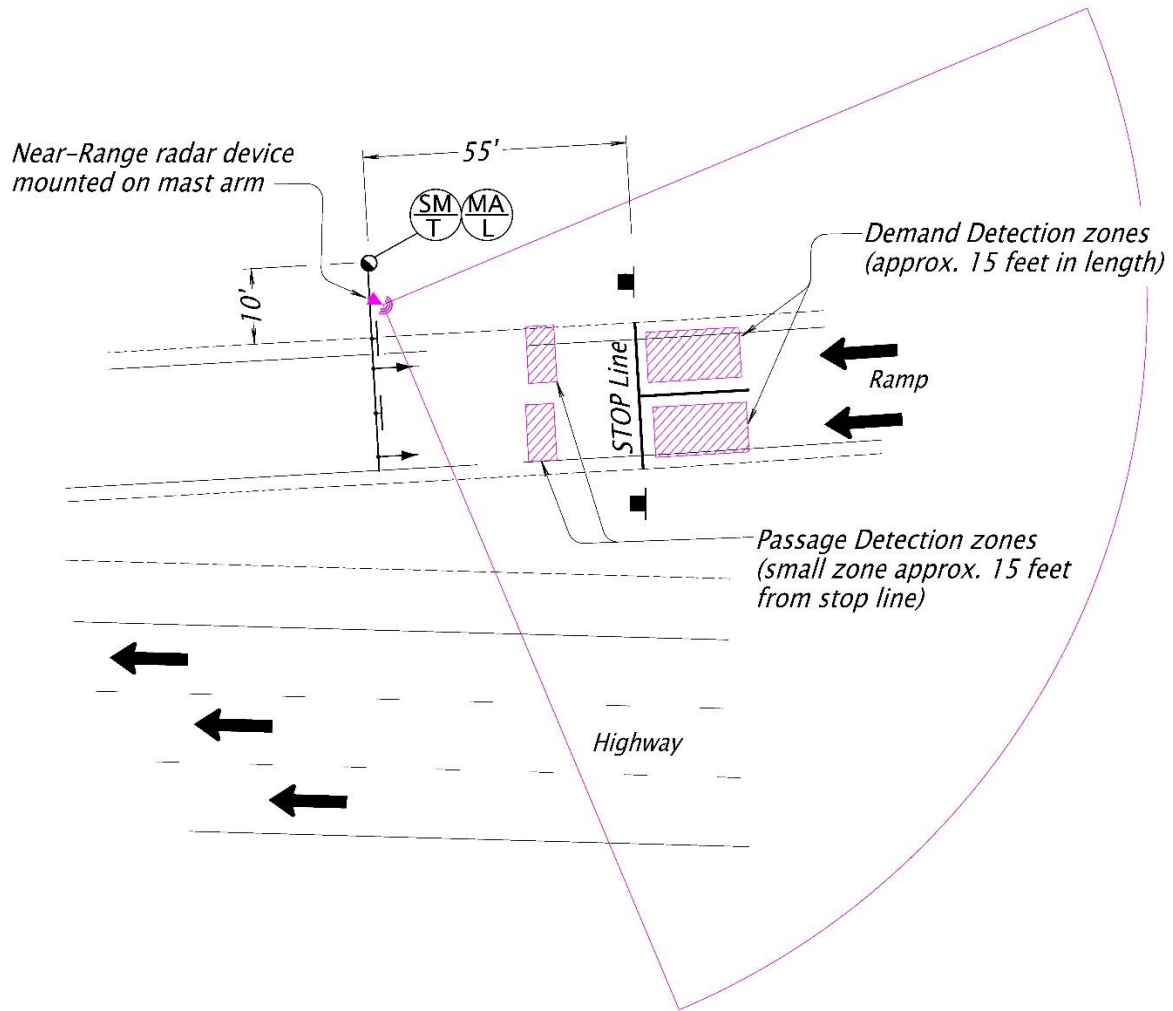
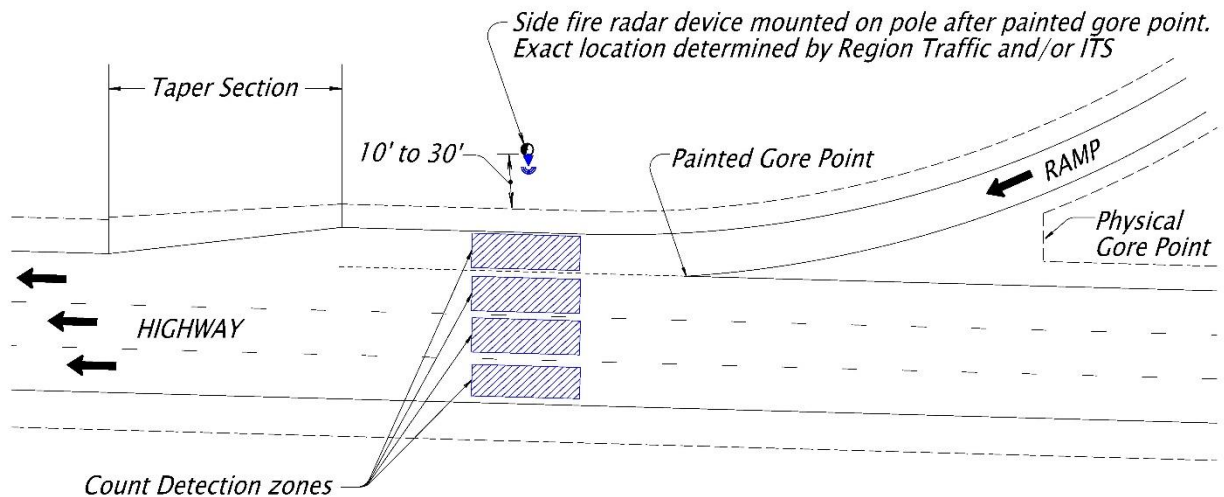

Figure 13-16 | Count Detection Layout, Detector Unit Mounted on Stand-Alone Pole



Note: not drawn to scale

13.6.2 334 Controller Cabinet Input Detection File

An SDLC connection is the default standard. When an SDLC connection is used, the input file is not used and will remain blank on the cabinet print. See chapter 6 and chapter 20 for more information. If the input file is used (e.g., loop detection), refer to older versions of the Signal Design Manual or contact the state traffic signal engineer for guidance on using the input file.

13.6.3 Detector Wiring Diagram

The detector wiring diagram for a ramp meter is no longer needed on the ramp meter plan sheet when non-invasive detection (radar) is used. The ramp meter timer will configure and document the detection zone set-up as per chapter 6 and chapter 20. If not using SDLC, coordinate with the ramp meter timer to ensure that the cabinet print accurately reflects the appropriate equipment in the input file.

13.7 Wiring

Ramp meters can have the potential for long distances of wire/cable (from the cabinet to the devices). The signal designer should verify the voltage drop and wire size of wiring for long runs of wire/cable as per chapter 5. The radar cable length should be less than 2000 feet. However, if more than 2000 feet is necessary, contact the state traffic signal engineer and the manufacturer for design solutions.

13.8 Background/Reference Information

This section contains more in-depth information to aid in understanding the guidance presented in this chapter and for documentation purposes.

13.8.1 Queue Detection History

Queue detection was a small zone located upstream of the stop line used to detect an extensive queue length. When an extensive queue length was detected (by a vehicle stopping on the queue detector for a pre-determined amount of time), the meter rate was increased as necessary to quickly dissipate the extensive queue. These queue detectors also activated a “BE PREPARED TO STOP” with “WHEN FLASHING” sign or a “STOPPED VEHICLES AHEAD” PTR sign if one was present.

Queue detection is longer used as there are now better ways to manage the ramp queue via the traffic signal timing at ramp terminal. The signal timing and ramp meter rate balances the needs of local and through traffic by allowing the ramp to queue at an acceptable level. Splitting single lane on-ramps into two-lanes when the ramp meter is active also helps provide more storage of vehicles on the ramp. The goal is to prevent overflowing queues onto the city street without the need to “flush” the ramp queue onto the freeway.

A review of all existing ramp meters revealed the “BE PREPARED TO STOP” with “WHEN FLASHING” or “STOPPED VEHICLES AHEAD” signs are rarely used. The older “STOPPED VEHICLES AHEAD” PTR sign was activated by the queue detection but has been retired since 2014 and is no longer used in new installations. See section 13.8.2 for more info. The PTR sign was replaced by the “BE PREPARED TO STOP” with “WHEN FLASHING” sign, but it was activated whenever the ramp meter was active (not activated via the queue detection).

Due to the “BE PREPARED TO STOP” with “WHEN FLASHING” not being activated by the queue detection, this sign is now retired as per the 2021 update to this manual. It has been replaced with a supplemental “RAMP METER ON WHEN FLASHING” sign if the sight distance to the ramp meter signal/queue is inadequate or a concern. The 2021 manual update simplifies the sign layout and warning message given to the driver. See section 13.3.1 and Figure 13-11 and Figure 13-12 for current guidance.

13.8.2 PTR sign History

In the past, ramp meters used three different part time restriction (PTR) signs for the standard ramp meter sign sequence:

- “RAMP SIGNAL ON”
- “FORM 2 LINES”
- “STOPPED VEHICLES AHEAD”

All three PTR signs were replaced with static aluminum signs (with a flashing beacon as appropriate) in January 2014. This change resulted a reduced initial installation cost and a reduced cost and time savings for maintenance repairs while still providing the necessary messages/information to the driver.