

OPERATIONS



Wickiup Water District, Oregon



2013. North Clackamas County Water Commission, OR. SSF Cleaning
(photo taken by Chris Johnsen, NCCWC)

CRITICAL VARIABLES THAT CAN IMPACT PERFORMANCE

Critical Variables

1. Raw water characteristics (temperature, particle characteristics, color, algae, nutrients, organic compounds, oxygen content).
2. Sand size (d_{10}) and uniformity (U)
3. Flow control and air binding
4. Head loss allowed
5. Sand bed depth
6. Filtration rate and variability
7. Maturity of the sand bed and biological organisms
8. Filter cleaning (frequency, length of time the filter is out of operation, ripening period)

FILTRATION RATE

Filtration rate should be continuous

1. Good for dissolved oxygen
2. Good for nutrient supply
3. Good for biological mechanisms
4. Influent flow should not scour sand surface
5. 0.1 gpm/ft² maximum filtration rate
6. 0.03 gpm/ft² minimum filtration rate
7. Cold temperatures may need lower filtration rates (e.g., 0.05 gpm/ft² when water temp < 5°C)
8. Controls should be in place to prevent the tail water (effluent side) from dropping below the sand bed during operation (e.g., an effluent weir) – this helps prevent vacuum conditions and air entrainment.



FLOW CONTROL – INLET VS OUTLET

Flow control can be practiced at the inlet or outlet. Inlet flow control can be either operated as constant rate or declining rate modes.

1. Inlet flow Control – Constant Rate

Uses a throttling valve plus a flowmeter or V-notch weir prior to each filter. The operator uses the flow control valve to set the desired filtration rate. As the resistance of the filter bed increases, the water level rises. When it reaches the overflow pipe the bed should be cleaned.

- Requires less operator involvement
- Ensures a more constant rate of filtration
- Allows operator to see headloss development as headwater rises
- Low headwater at the beginning of filter runs may make filters more vulnerable to freezing in the winter if filters are not covered or insulated

2. Inlet Flow Control – Declining Rate

Uses a hydraulic control valve with a flowmeter and valve at the raw water line prior to each filter that regulates flow while maintaining a constant water surface elevation above the filter. Effluent flow decreases as the filter plugs.

- Headwater level is not indicative of headloss development (piezometers or pressure gages are needed)
- Decline in effluent rate or approach to terminal headloss indicates cleaning

CONSTANT RATE INLET CONTROL

- Starts off with a lower headwater level
- Influent valve is set to the desired rate (e.g., 0.1 gpm/ft²)
- Outlet valve is fully open
- The filter will need to be cleaned when the headwater approaches the overflow

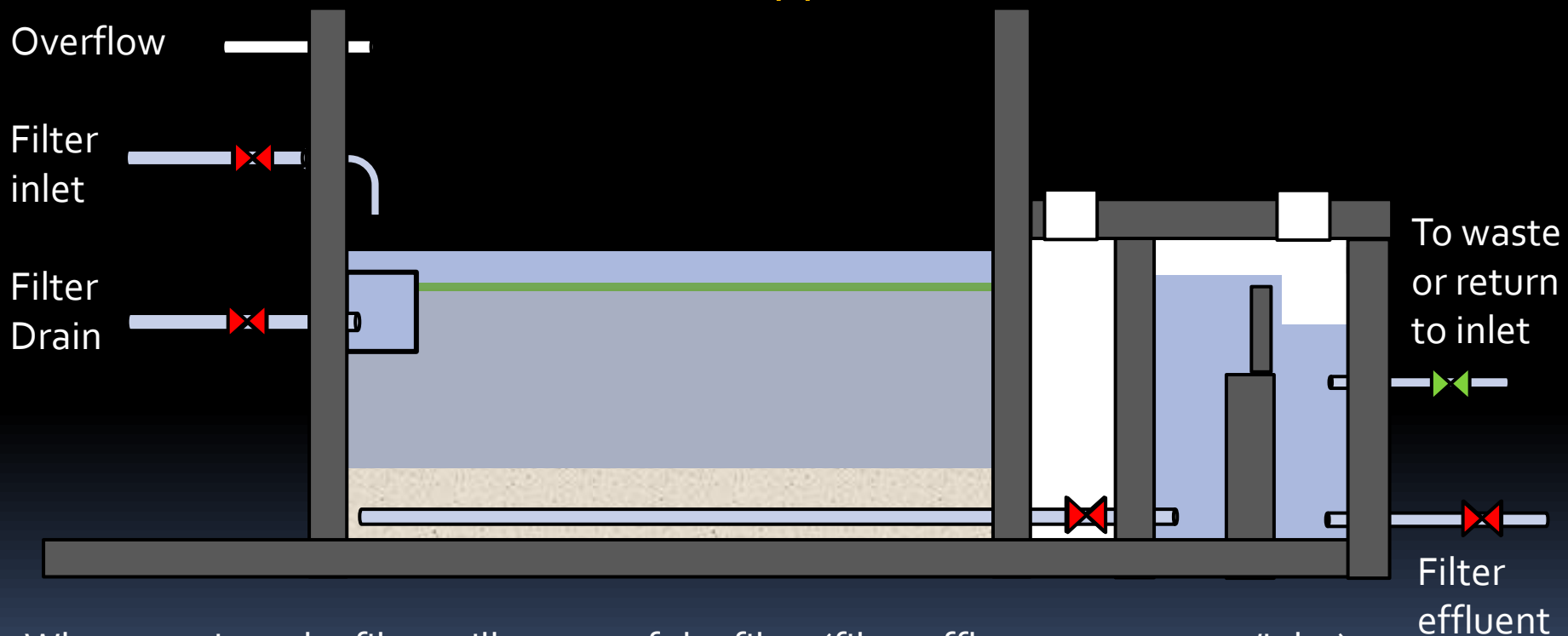

What goes into the filter will go out of the filter (filter effluent or to waste/inlet)

Headloss builds up towards the end of the filter run as it plugs up causing headwater to rise

Cleaning unplugs filter allowing headwater to drop

Excess water produced is re-circulated (pumped) to influent or sent to waste (gravity)

FLOW CONTROL – INLET VS OUTLET

3. Outlet Flow Control (declining rate)

Uses a control valve and flowmeter on the outlet pipe from each filter. As the filter plugs, the filtration rate will decrease, even if the headwater level is increased. The level of water on top of the filter can be controlled by using float switches to turn on and off raw water pumps or control inlet control valves. Excess water can also be diverted out an overflow and directed back to the source.

- Most common
- Fairly simple control method although operator involvement is higher if no automation is used
- Higher rates may be implemented faster for emergency situations, since you don't have to wait for headwater to rise as with constant rate influent control.
- Ability to maintain higher headwater level provides better protection from freezing.
- Higher headwater level provides raw water storage should influent flows be interrupted due to power failure or intake shutdown due to damage or to avoid high turbidity events.
- Headwater level is not indicative of headloss development (piezometers or pressure gages are needed)

DECLINING RATE OUTLET CONTROL

- Starts off with a higher headwater level
- Influent valve is adjusted to keep filter from overflowing
- Outlet valve is partially closed at first and then is gradually opened as the yield drops due to filter plugging
- The filter will need to be cleaned when the yield cannot keep up with demands

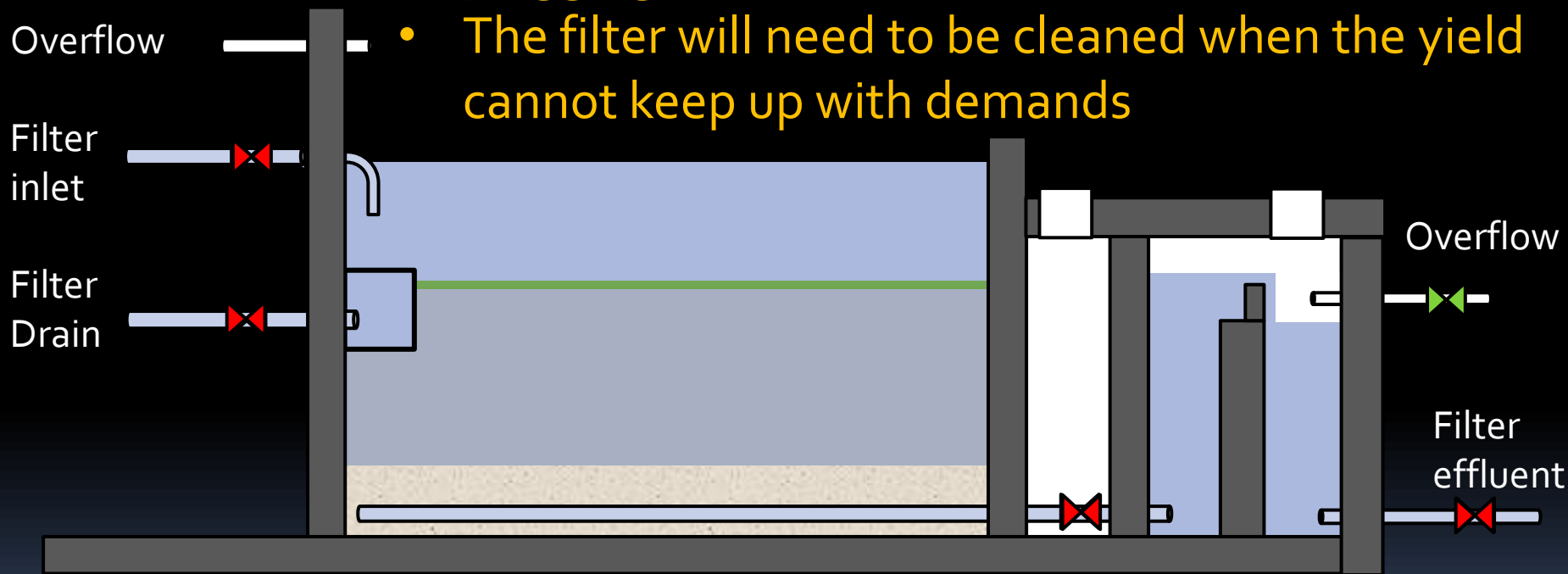

What goes into the filter will go out of the filter (Excess can be overflowed if needed)
Headloss builds up towards the end of the filter run as it plugs up causing headwater to rise
Cleaning unplugs filter allowing headwater to drop and yield to recover
Influent water is balanced with effluent or excess can be overflowed from headwater

FLOW MEASUREMENTS

Flow can be measured using weirs (square, v-notch), orifice plates, or flow meters.



Flow calculation for V-notch weir with a 60 degree angle:

$$Q = 1.44 H^{5/2}$$

Where:

$Q = \text{ft}^3/\text{second}$

$H = \text{height of water level above weir crest (ft)}$

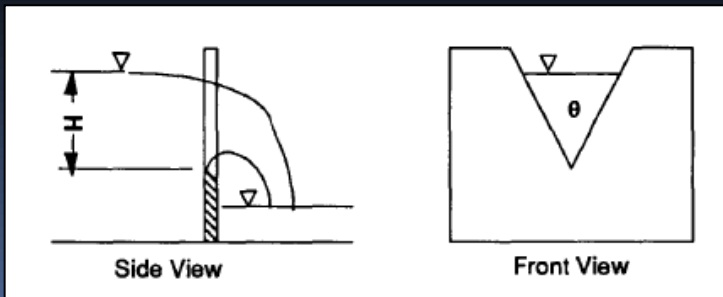

FLOW MEASUREMENTS

Flow calculation for rectangular weir:

$$Q = C_w * (2 * g)^{0.5} * b * H^{3/2}$$

Where:

$Q = \text{ft}^3/\text{second}$

$H = \text{height of water level above weir crest (ft)}$

$g = 32.2 \text{ ft/s}^2$ (gravity)

$b = \text{length of weir crest (ft)}$

$C_w = \text{weir coefficient where } C_w = 0.40 + (0.05 * (H/P))$ where $P =$
distance in feet from floor of channel to weir crest

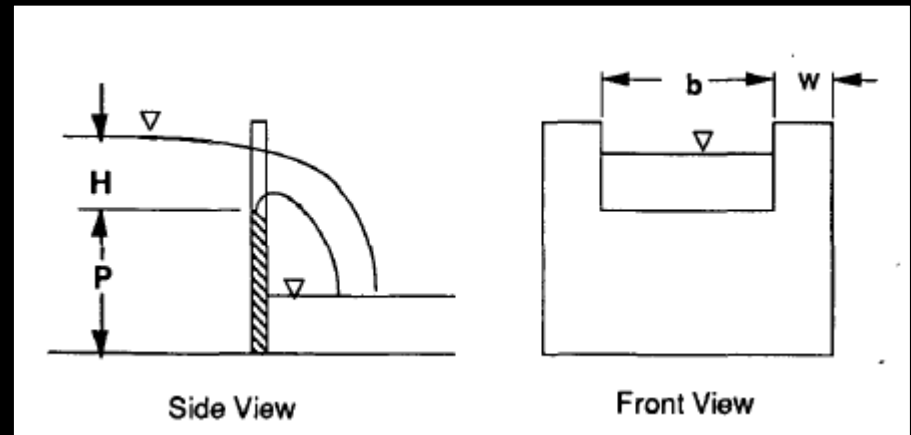

FLOW MEASUREMENTS

Rectangular weir flow determinations:

Flow calculations for rectangular weir – Yellow cells indicate acceptable range of filtration rates from 0.03 – 0.1 gpm/ft² (with unit conversions for H & P in inches and Q in gpm, MGD, or gpm/ft²)

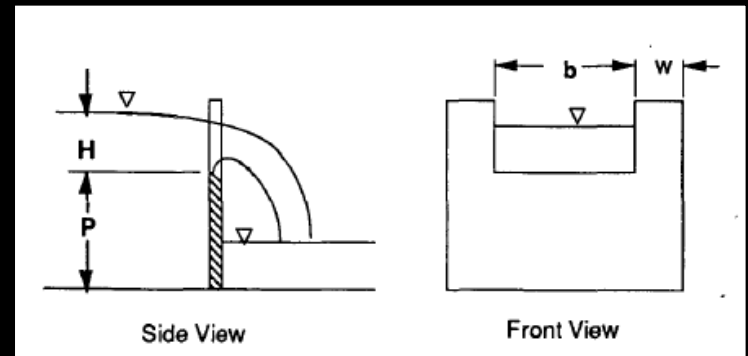

$$Q = C_w * (2 * g)^{0.5} * b * H^{3/2}$$

$$C_w = 0.40 + (0.05 * (H/P))$$

Weir Parameters			Q (gpm)			Q (MGD)			Q (gpm/ft ²) w/ 1,000 ft ² Filter Area		
H (inches)	P (in)	C _w (ft ³ /s)	b = 1 ft	b = 2 ft	b = 3 ft	b = 1 ft	b = 2 ft	b = 3 ft	b = 1 ft	b = 2 ft	b = 3 ft
0.25	72	0.4002	4.3	8.7	13.0	0.006	0.012	0.019	0.004	0.009	0.013
0.5	72	0.4003	12.3	24.5	36.8	0.018	0.035	0.053	0.012	0.025	0.037
0.75	72	0.4005	22.5	45.1	67.6	0.032	0.065	0.097	0.023	0.045	0.068
1	72	0.4007	34.7	69.4	104.1	0.050	0.100	0.150	0.035	0.069	0.104
1.25	72	0.4009	48.5	97.1	145.6	0.070	0.140	0.210	0.049	0.097	0.146
1.5	72	0.4010	63.8	127.7	191.5	0.092	0.184	0.276	0.064	0.128	0.192
1.75	72	0.4012	80.5	160.9	241.4	0.116	0.232	0.348	0.080	0.161	0.241
2	72	0.4014	98.4	196.7	295.1	0.142	0.283	0.425	0.098	0.197	0.295

CLEANING (SCRAPING/HARROWING)

Factors that impact filter cleaning:

1. Cleaning method (scraping or harrowing)
2. Cleaning mechanisms (hand shovel or larger equipment)
3. Presence of 2 or more filter beds (the more filters, the smaller the area to be cleaned at any one time)
4. Room to stage equipment, stockpile sand, etc.
5. Other provisions to minimize down time during cleaning
6. Monitoring capability (individual and combined filter effluent turbidity, taps to sample for individual filter effluent coliform bacteria, turbidity, and other parameters, and filter-to-waste effluent taps for monitoring coliform and turbidity during the ripening period)
7. Ability to measure sand bed depth (keyway, staff gage (shown), etc.)



WHEN TO CLEAN

Cleaning is needed when either terminal head loss is reached (i.e., headwater reaches the overflow level) or when filter effluent is unable to keep up with system demands.

This graph shows head loss increase, while permeability decreases towards the end of each filter run.

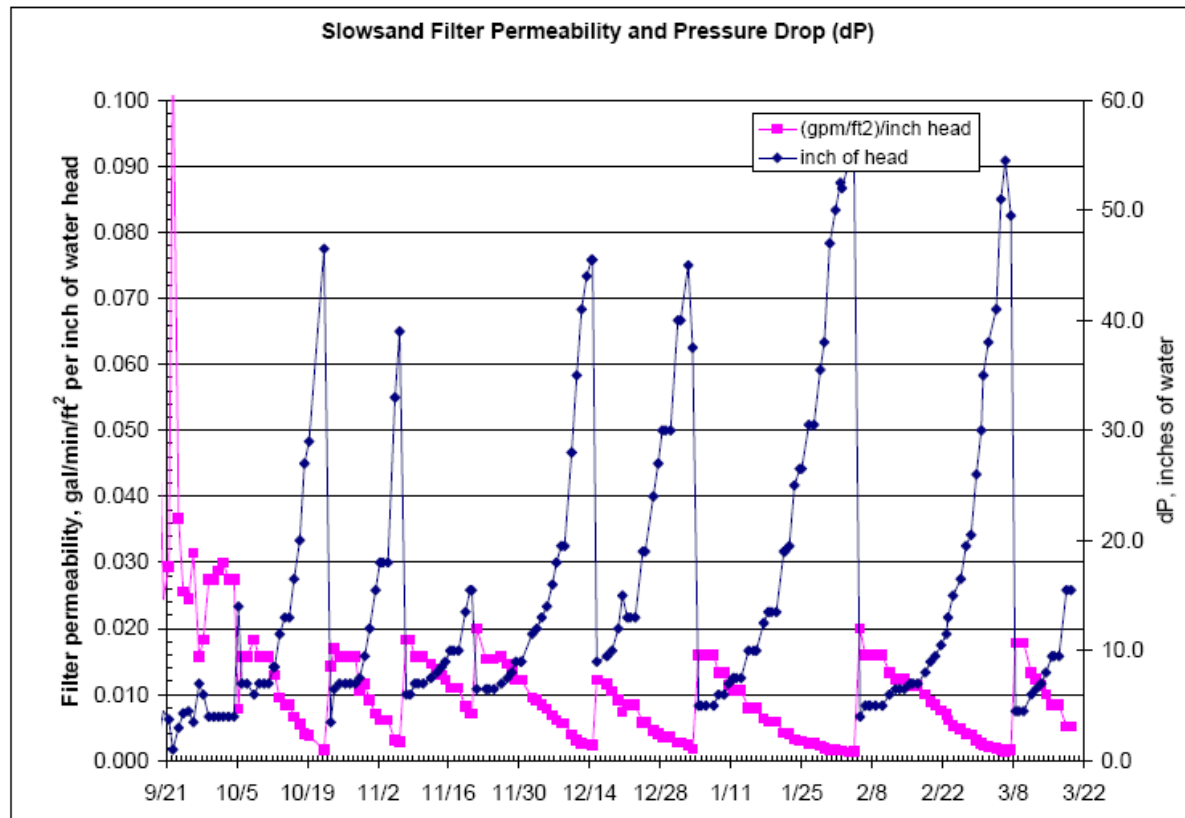

Figure B-7 of 37 - SSF-Perm&dP

PREDICTING WHEN TO CLEAN

Daily measurement of headwater (influent or supernatant water) and tailwater (effluent or permeate water) levels can be used to develop plots of headloss versus time (like the one shown below), which can then be used to predict when the filter will need to be cleaned.

Note: The clean bed headloss through 4-ft of media is only about 10 inches, depending on effective size and filtration rate, which only amounts to a decrease in filter run of 2-3 days as compared with a 3-ft deep bed (HL ~ 8 inches)

Headloss = headwater elevation – tailwater elevation

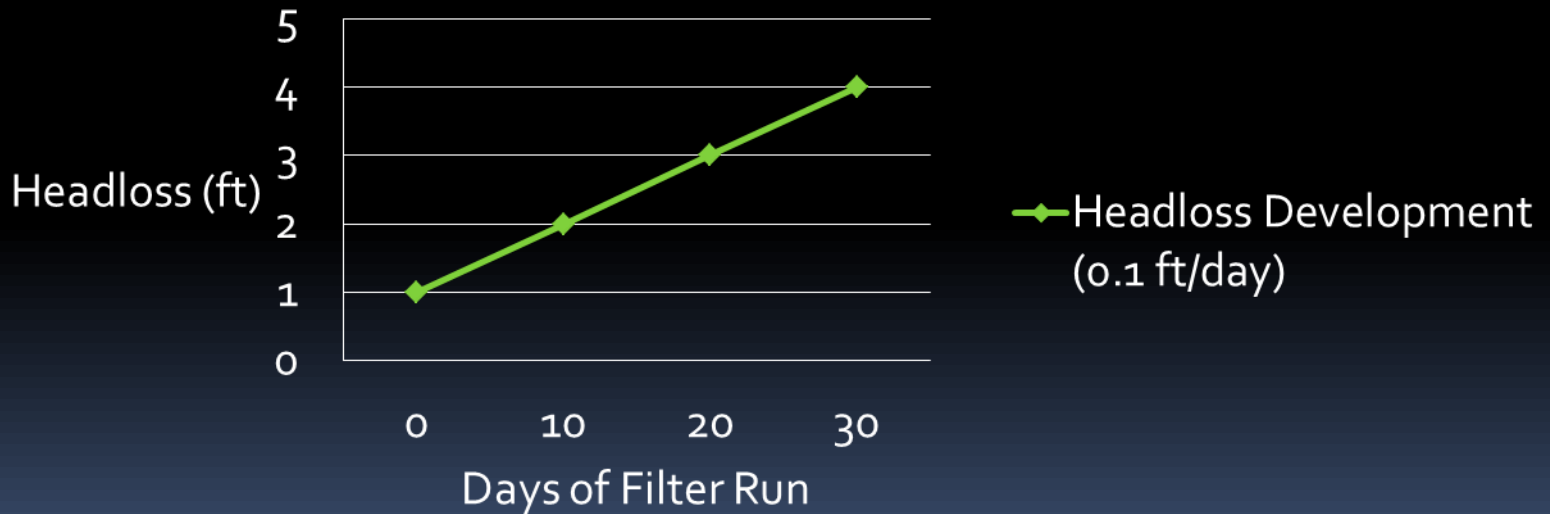

For the graph shown, if the terminal headloss = 5-ft
then cleaning is predicted to be needed in 50 days = 5-ft / (0.1ft/day)

PREDICTING WHEN TO CLEAN

Headloss development is exponential towards the end of a filter run

Headloss = headwater elevation – tailwater elevation

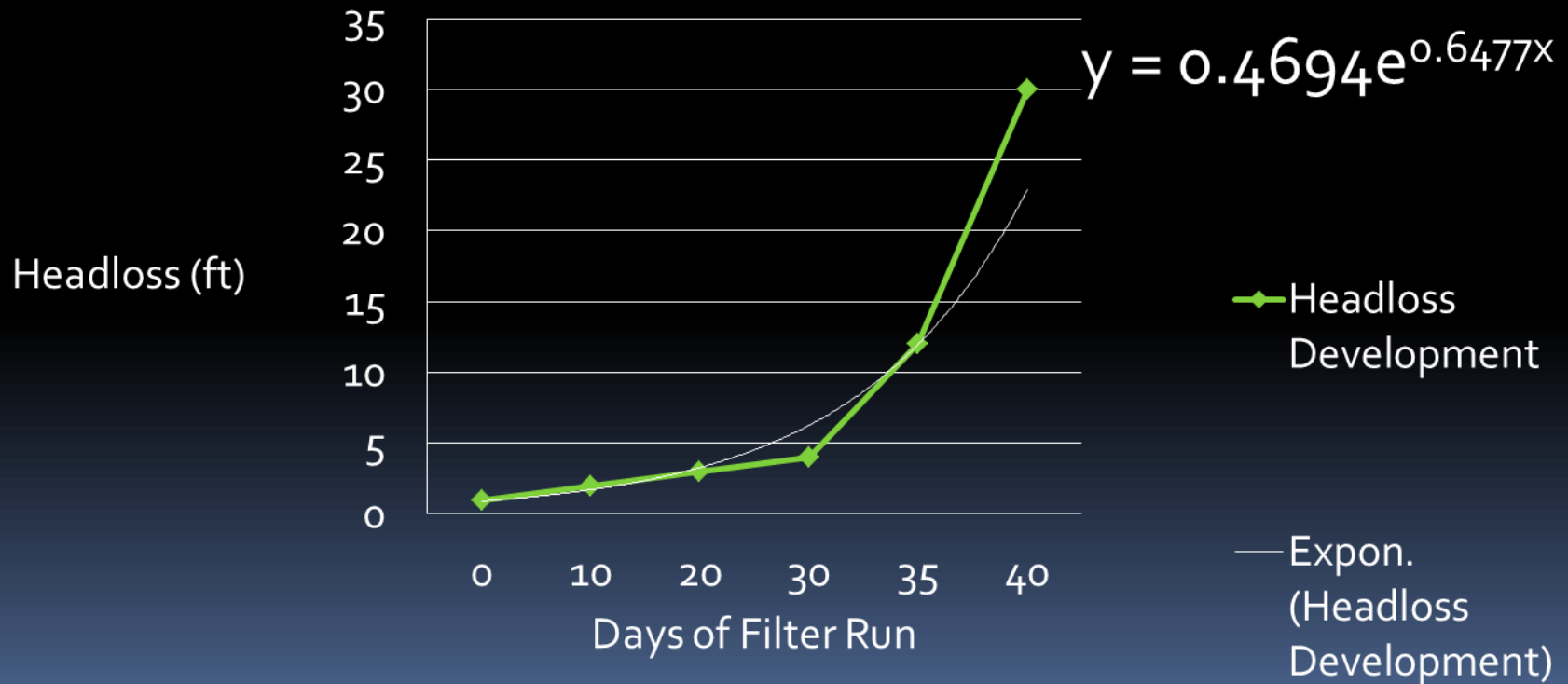

CLEANING METHOD

Cleaning can be accomplished by either:

1. Scraping or
2. Harrowing



2009. Wickiup Water District in Clatsop County, OR

SCRAPING PROCESS

Scraping Process (also called dry skimming)



- 1) Water is lowered to approximately 2-12" below the sand level (to be able to safely walk and maneuver machinery around);
- 2) Schmutzdecke and plugged sand (1-2 cm) is scraped with either flat shovels or specially designed machinery;
- 3) The debris is then conveyed out of the filter bed using a wheel borrow or dump truck;
- 4) The beds are leveled;
- 5) Slowly re-filled from the bottom with filtered unchlorinated water to about 12" above the sand (this prevents sand scour that may occur from top filling)
- 6) Slowly filled from the top the remaining amount; and
- 7) Filtered to waste until fully ripened.

SCRAPING PHASE 1

Shut off raw water inlet
and let filter drain down
(overnight for larger filters)
Or use supernatant drain
for smaller filters

Filter to be Scraped

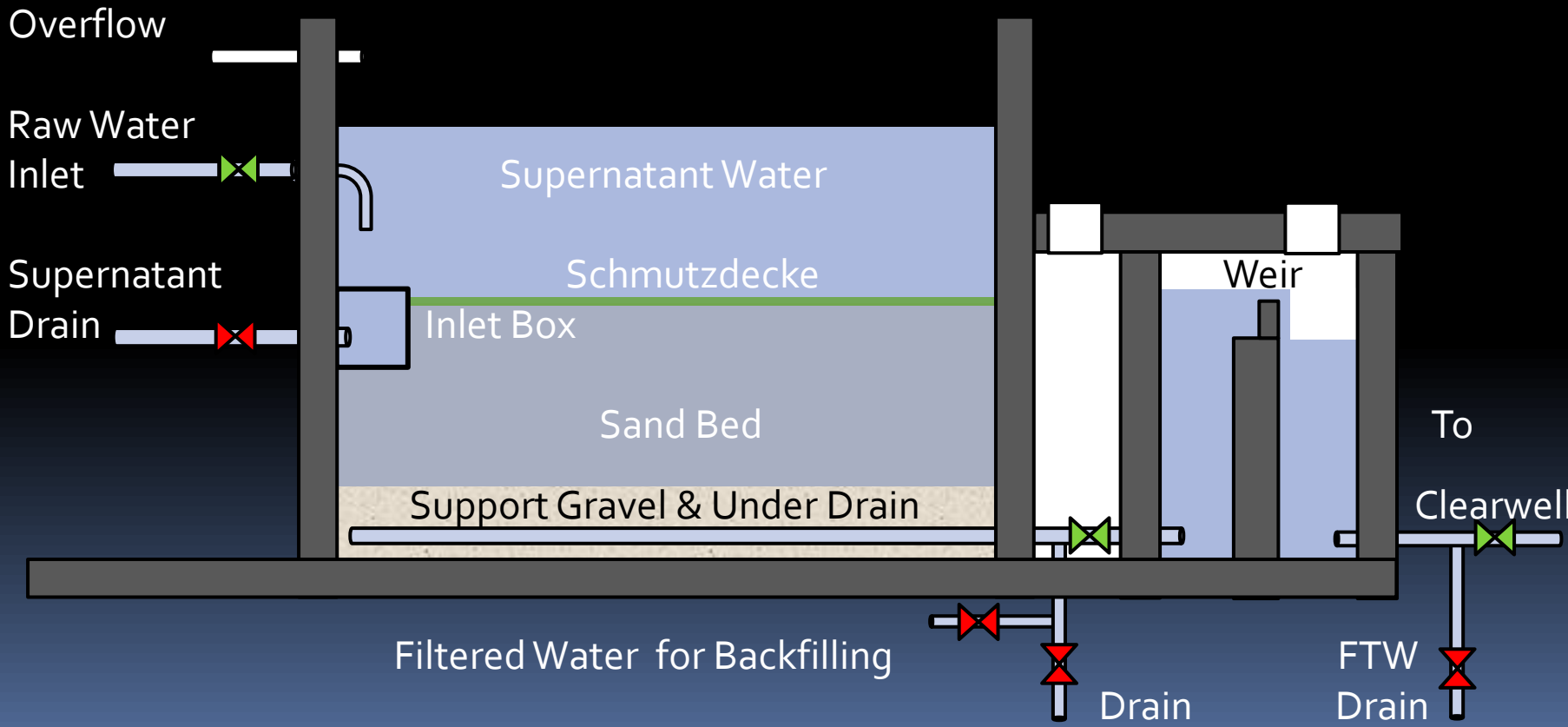

SCRAPING PHASE 2

- Shut off the effluent valve to the clear well;
- Open the supernatant drain to drain off any remaining water; and
- Drop the weir to lower the water level 2-24" below the sand.

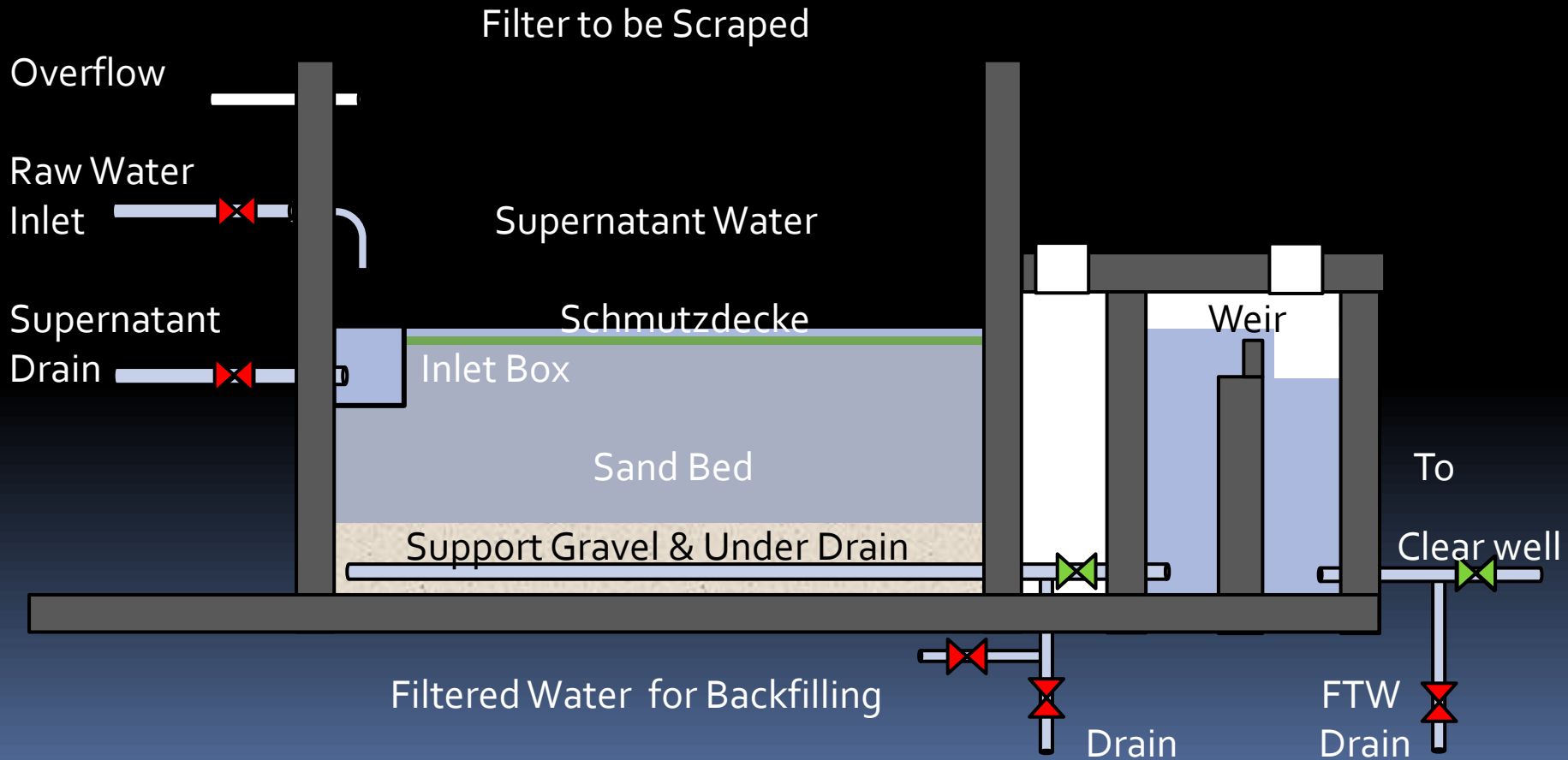

SCRAPING PHASE 3

- Scrape the schmutzdecke and roughly $\frac{1}{4}$ - $\frac{1}{2}$ inch (0.635 – 1.27 cm) of sand from the filter.
- Close the supernatant drain, raise the weir and then begin re-filling from the bottom with filtered water at a rate below that which would fluidize the sand (around 0.3-0.6 ft/hr (0.1 – 0.18 m/hr or 0.0374 – 0.0748 gpm/ft²)) This purges air from the sand bed.
- Continue filling until the supernatant water is 12 inches above the sand bed – this prevents scouring when raw water is introduced from the top.

Filter to be Scraped

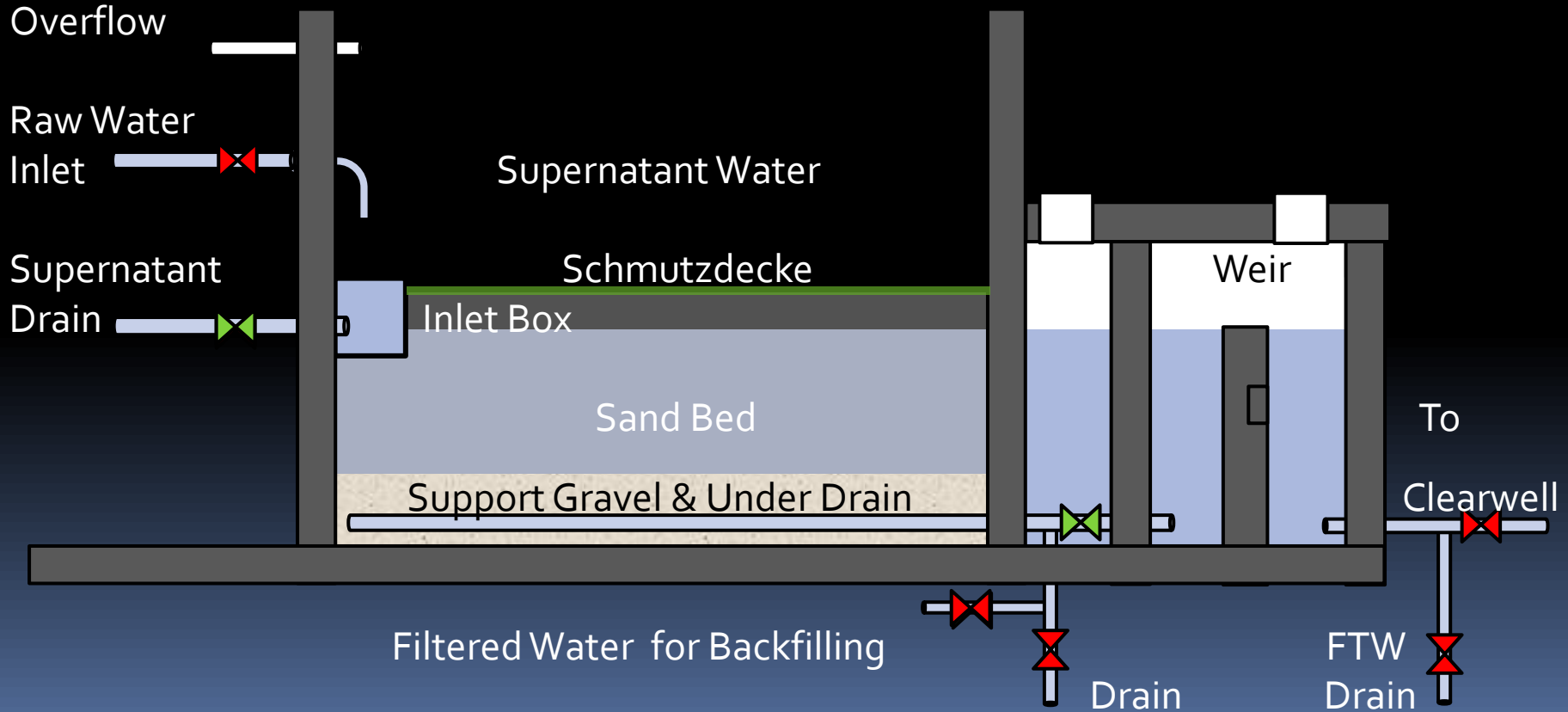

SCRAPING PHASE 4

- Stop filling from the bottom and introduce raw water from the top to fill to a supernatant depth of 4-5 feet.
- Begin filtering to waste at around 0.1 gpm/ft² for 24-48 hrs for ripening until turbidity is ≤ 1 NTU and coliform counts are ≤ 10 CFU/100 ml.

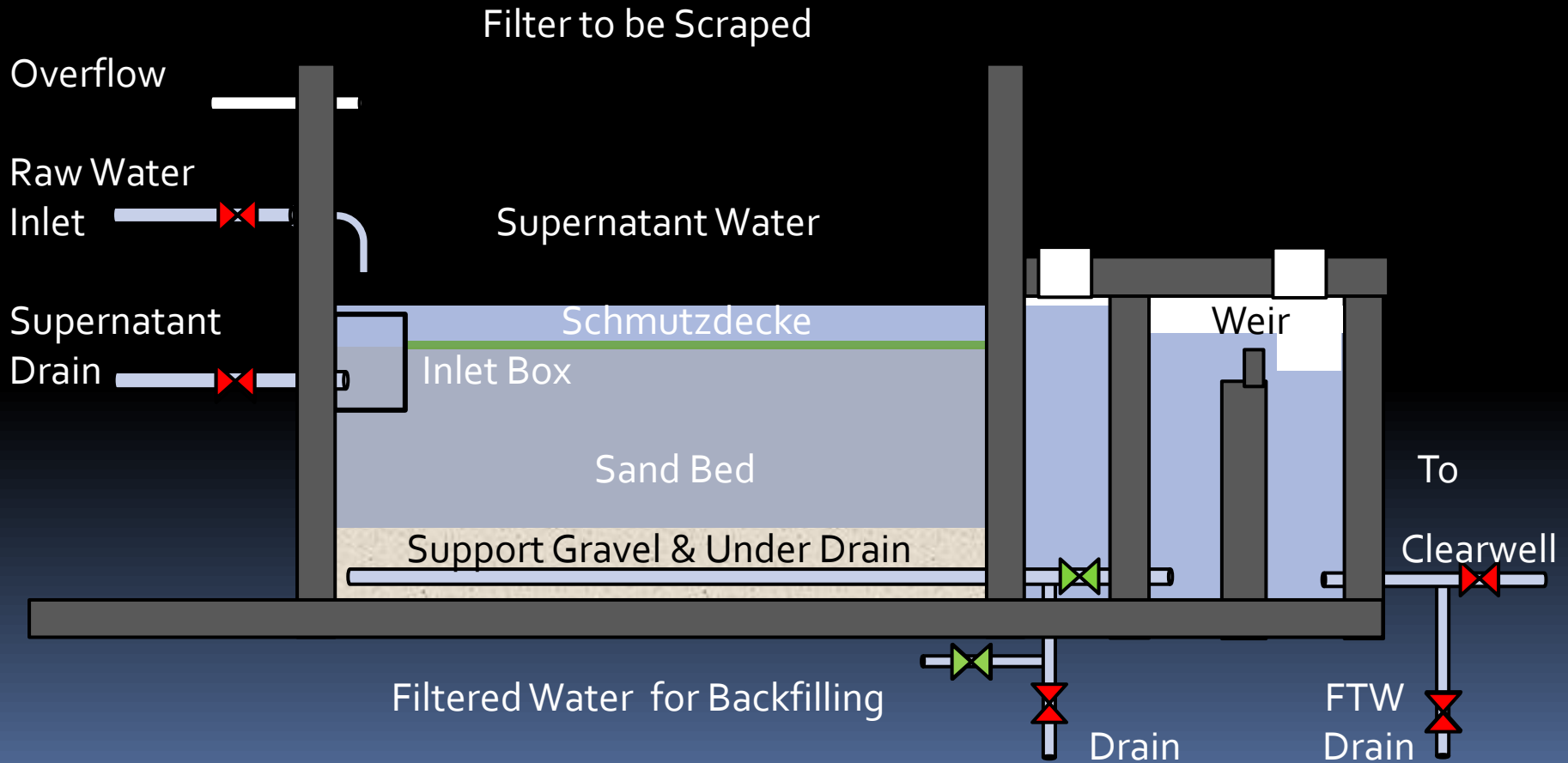

SCRAPING

Scraping

Schmutzdecke on the left and sand on the right



SCRAPING METHOD

Scraping Method

1. hand shovel
2. larger equipment



Photo courtesy of Stephen Baker, WA DOH



2013. North Clackamas County Water Commission, OR. SSF Cleaning (photo taken by Chris Johnsen, NCCWC)

SCRAPING BY HAND

Hand Scraping Tools

1. Asphalt lute (top)
2. Snow shovel (lower right)
3. Flat blade, square point transfer shovels (lower left)
4. Wheelbarrow or 5-gal buckets (for removal from filter bed)



SCRAPING BY HAND

Hand scraping at Empire, Colorado, filter:

1. Scrape schmutzdecke and top 0.5 cm of sand bed into windrows using asphalt lute
2. Shovel scraped material from windrows into 5-gallon buckets [or could use wheelbarrow] for removal
3. Cleaning Rate = 205 ft² / person / hr

Note:

- Avoid treading directly on schmutzdecke
- Use plywood and planks to keep from treading on or running wheelbarrows on sand bed

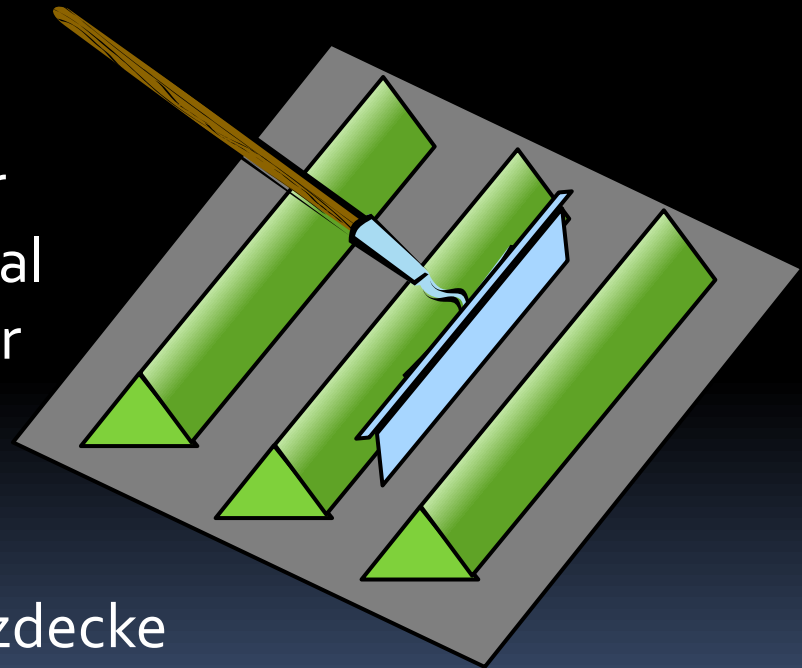

SCRAPING BY HAND

Hand scraping filter:



SCRAPING BY HAND

Scraping

1. hand shovel

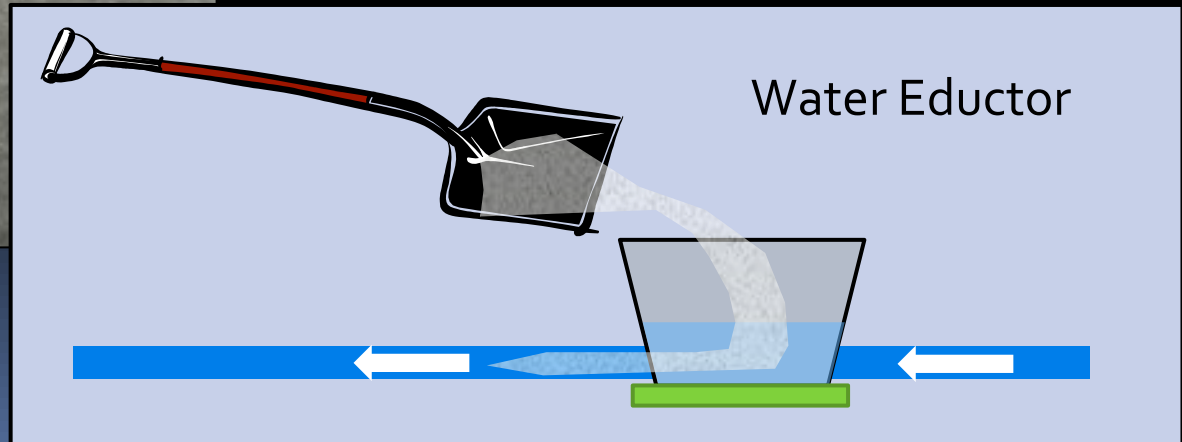

Photos courtesy of Stephen Baker, WA DOH

SCRAPING BY HAND

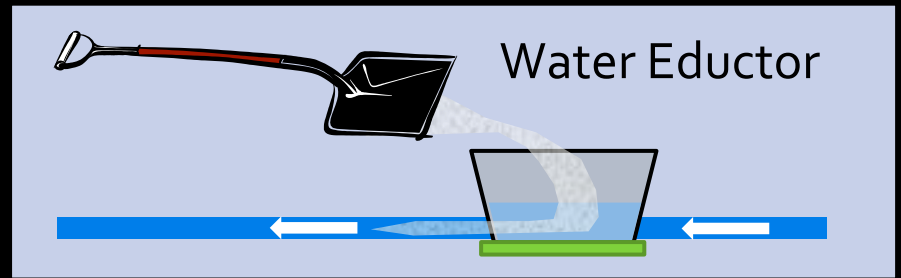
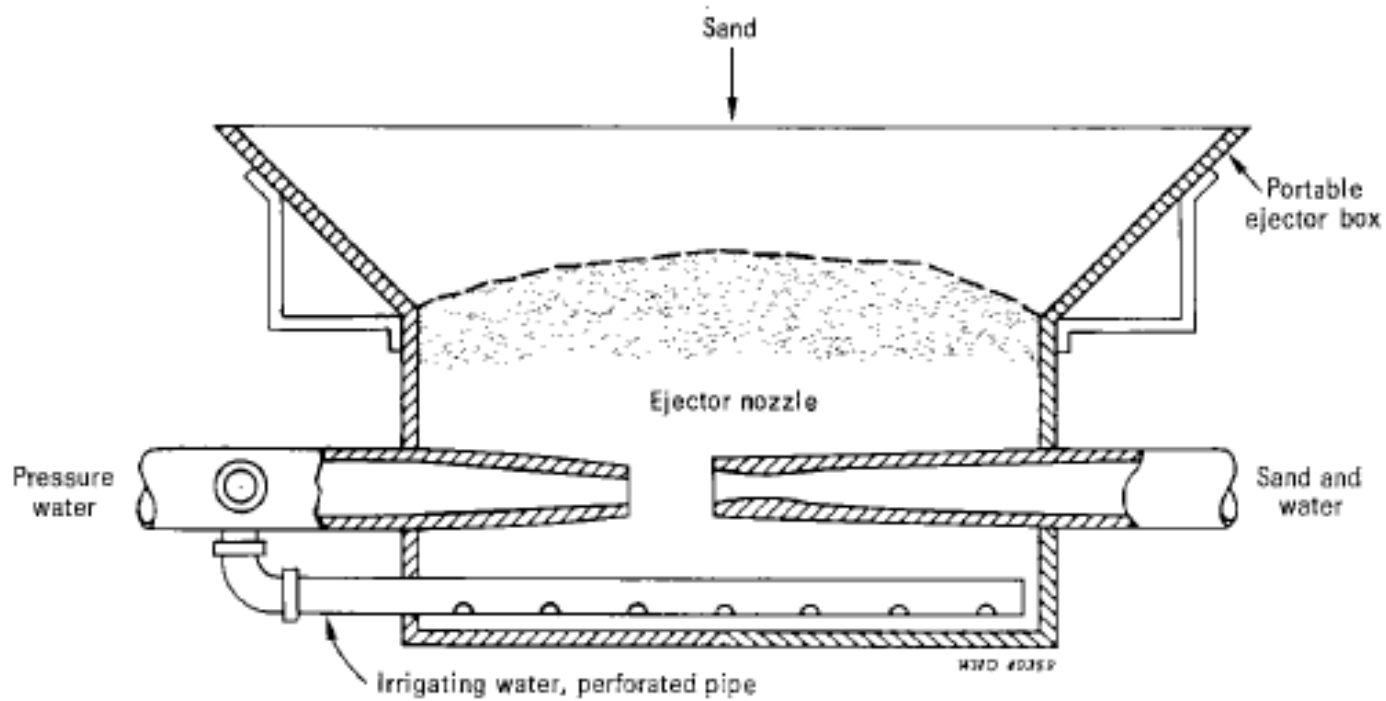

FIG. 32. HYDRAULIC SAND EJECTOR



From: Fair, G.M. & Geyer, J.C. (1954) *Water supply and waste-water disposal*, New York, John Wiley.

WASHING SAND

Washing Sand

hand shovel => eductor =>

Washer =>

Sand filter or stockpile



Photos courtesy of Stephen Baker, WA DOH

SAND WASHING PROCESS

This diagram illustrates the sand washing and grading process

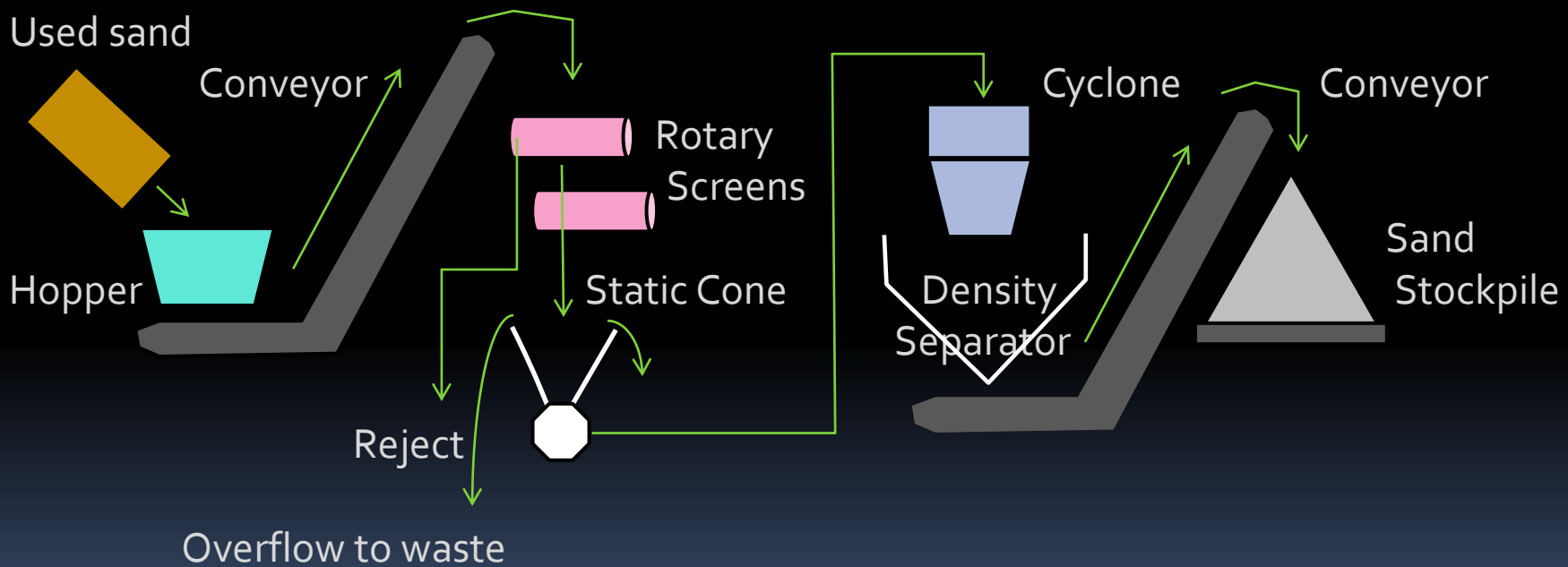

SCRAPING MACHINES

Scraping

1. larger equipment



2013. North Clackamas County Water Commission, OR. SSF Cleaning (photo taken by Chris Johnsen, NCCWC)

SCRAPING MACHINES

Scraping

scraping blade

The blade height
can be set for
precise filter
media skimming
thickness
tolerances

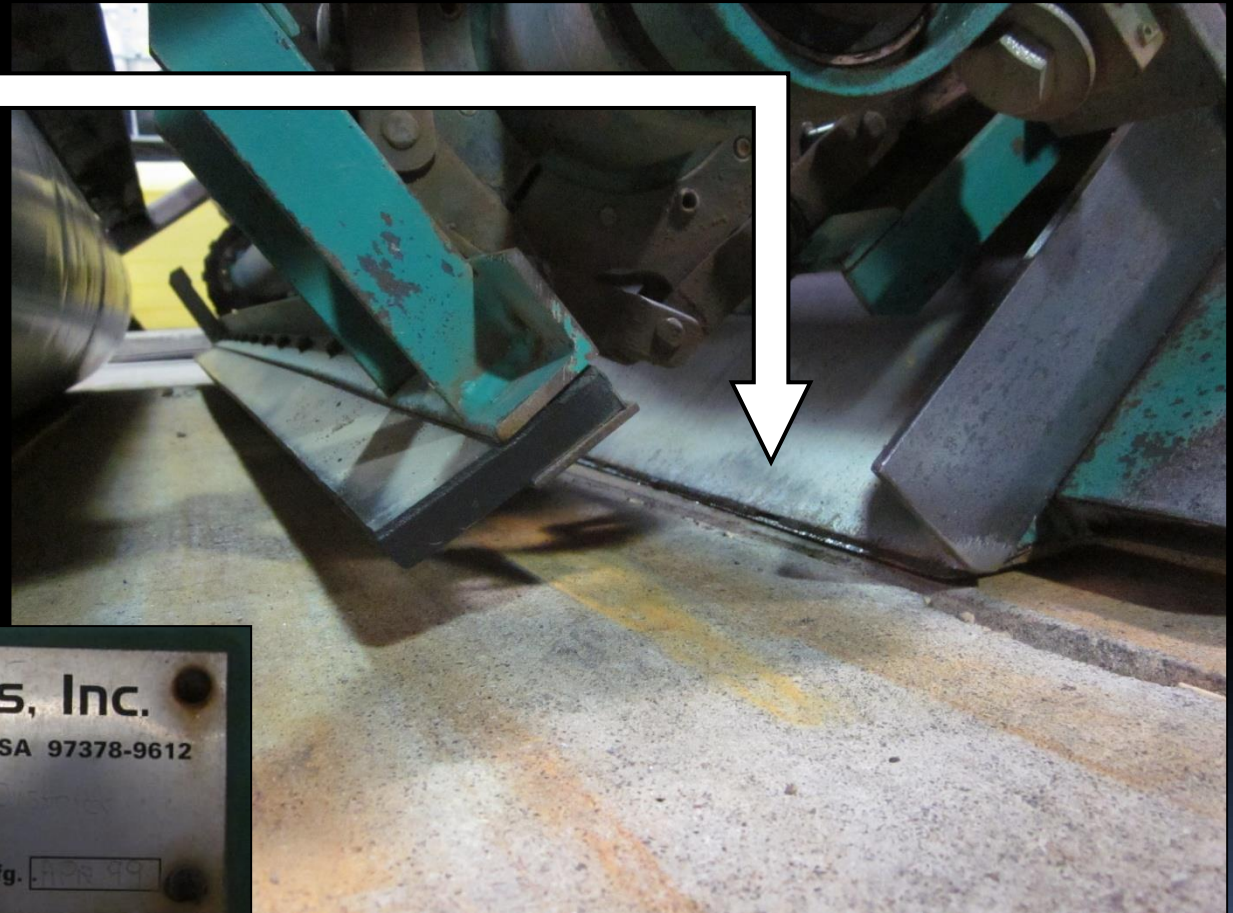

2013. North Clackamas County Water Commission, OR. SSF Cleaning (photo taken by Alan Schacht, NCCWC)

SCRAPING MACHINES

Scraping

1. larger equipment



2013. North Clackamas County
Water Commission, OR. SSF
Cleaning (photo taken by Chris
Johnsen, NCCWC)

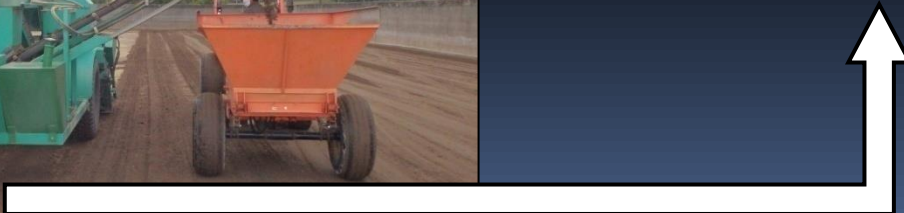

SCRAPING MACHINES

USG Puma 2400 "Sand Skimmer"

skimming thickness tolerances
between 0-100 mm (0 – 4 inches) at a rate
of up to 16,000 ft²/hr (4,240 ft³/hr)



2011, City of Salem , OR SSF Cleaning Machine
USG Puma 2400 "Sand Skimmer"





Scraping
USG Puma 2400



www.youtube.com/embed/g259QNQRbDY

USG Puma 3000

www.youtube.com/embed/AtX65tbf1q8



Scraping
USG Puma 2400



www.youtube.com/embed/g259QNQRbDY

USG Puma 3000

www.youtube.com/embed/AtX65tbf1q8

Scraping USG Puma 2400



www.youtube.com/embed/g259QNQRbDY

USG Puma 3000

www.youtube.com/embed/AtX65tbf1q8

Scraping USG Puma 2400



www.youtube.com/embed/g259QNQRbDY

USG Puma 3000

www.youtube.com/embed/AtX65tbf1q8

Scraping USG Puma 2400



www.youtube.com/embed/g259QNQRbDY

USG Puma 3000

www.youtube.com/embed/AtX65tbf1q8

Scraping USG Puma 2400



www.youtube.com/embed/g259QNQRbDY

USG Puma 3000

www.youtube.com/embed/AtX65tbf1q8

HARROWING PROCESS

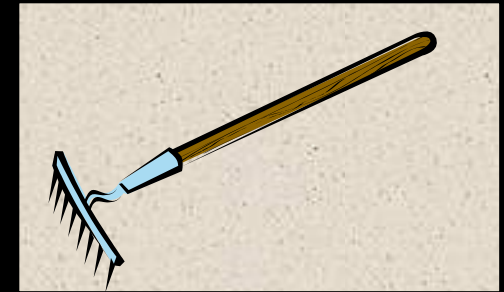

Harrowing Process (also called wet harrowing)

1. Water is lowered to approximately 6" above the sand level;
2. Water is introduced to provide a cross flow at a rate of about 20 gpm/ft² of cross-sectional area (e.g., 1,000 gpm for 6" water depth in a 100-ft long filter);
3. Filtered, unchlorinated water is introduced from the bottom to provide a "backflow", which keeps debris from sinking into the filter bed;
4. Stiff tined rake or harrow equipment is run over the top of the sand;
5. The debris (not sand) is then conveyed out of the filter bed from a harrow drain located just above the sand bed;
6. The beds are leveled;
7. Slowly re-filled from the bottom to about 12" above the sand (this prevents sand scour that may occur from top filling)
8. Slowly filled from the top the remaining amount; and
9. Filtered to waste until fully ripened, which is typically shorter than scraping.

HARROWING EQUIPMENT

Harrowing Equipment

Wet harrowing can be done with a chain harrow, comb-toothed harrow, or a stiff tined rake.



HARROWING SMALL FILTERS

Wet harrowing is a common method of cleaning small filters.

Basic process:

1. Lower water level to ~6" above the top of the sand.
2. Use a rake or rake-like Mechanism
3. agitate top 2"-3" of sand while slowly backflushing with filtered, but unchlorinated water

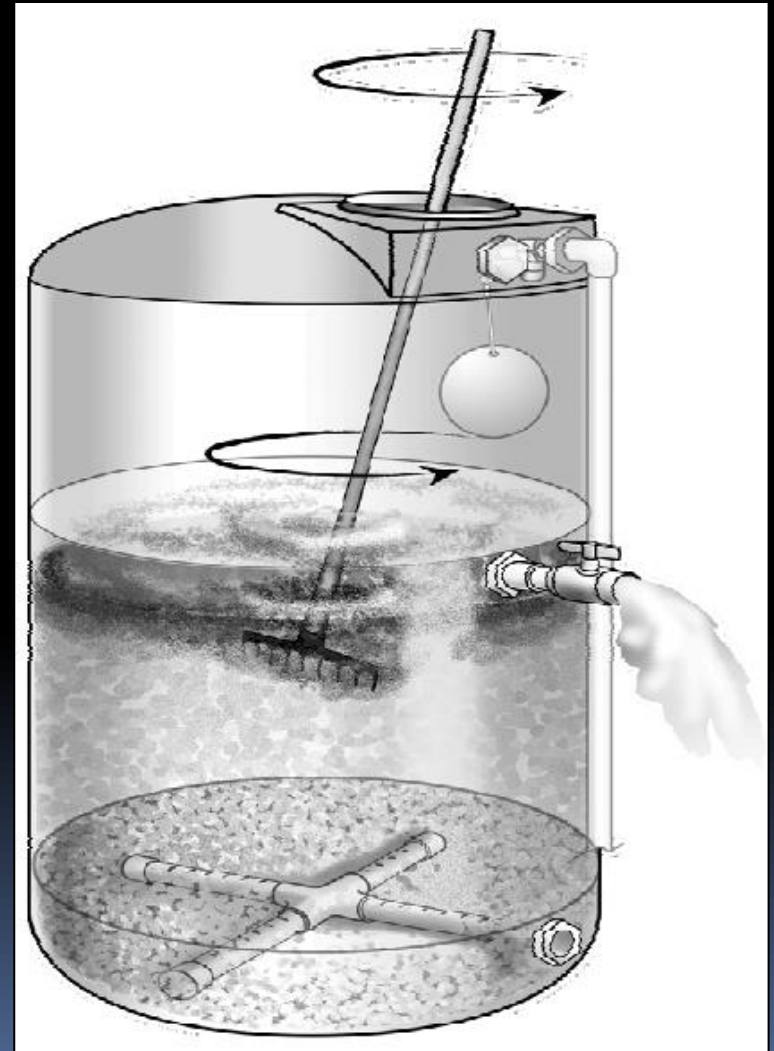

HARROWING SMALL FILTERS

Harrowing small
3-gpm filters using a
stiff-tined
garden rake.

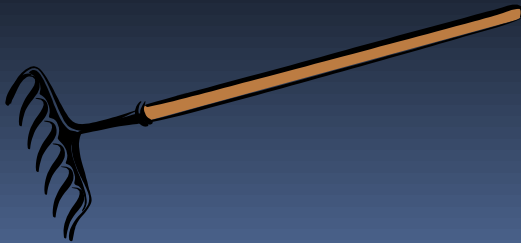

HARROWING PIPING

Blue Future Filters rely on a wet harrowing process

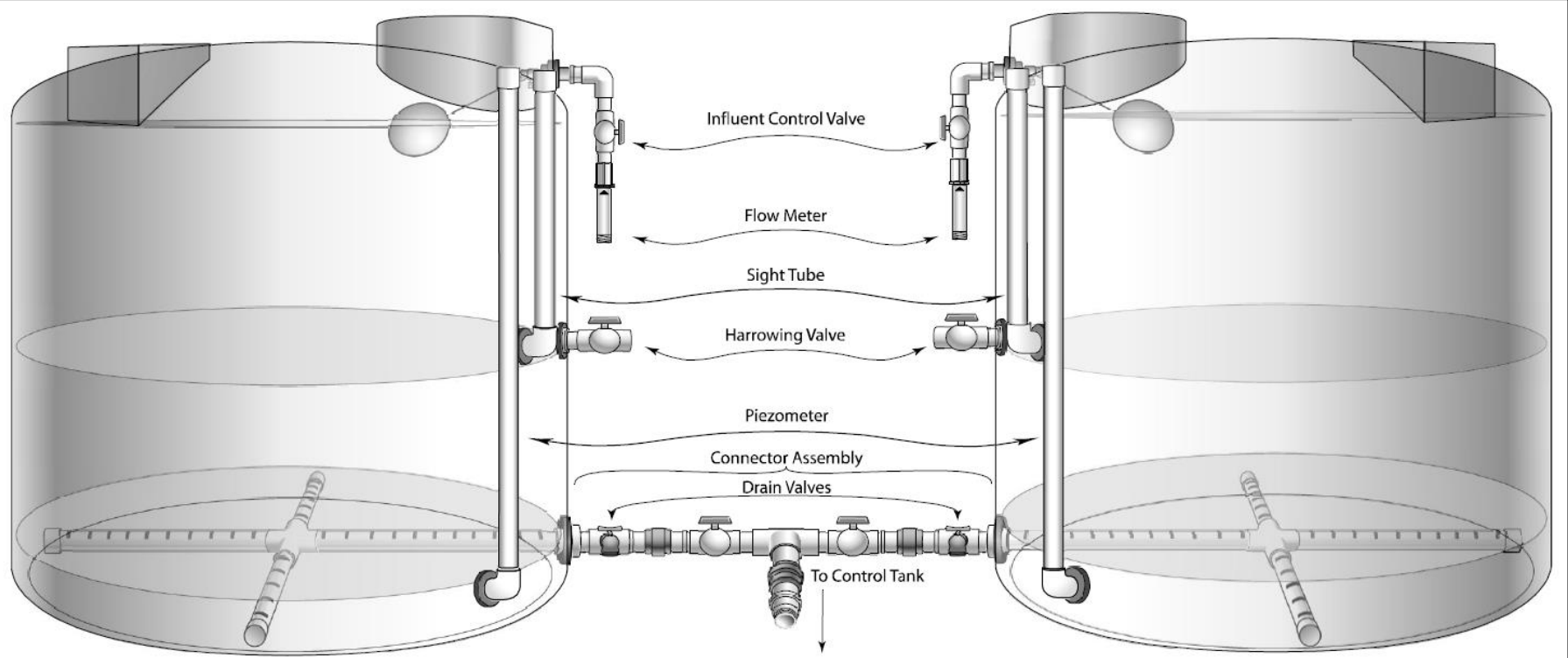

A slow sand filter with two tanks and tank-connector assembly.

HARROWING VALVE

Harrowing



Harrowing Valve
and Waste Line



HARROWING VALVE WASTE LINE

Inlet float control valve

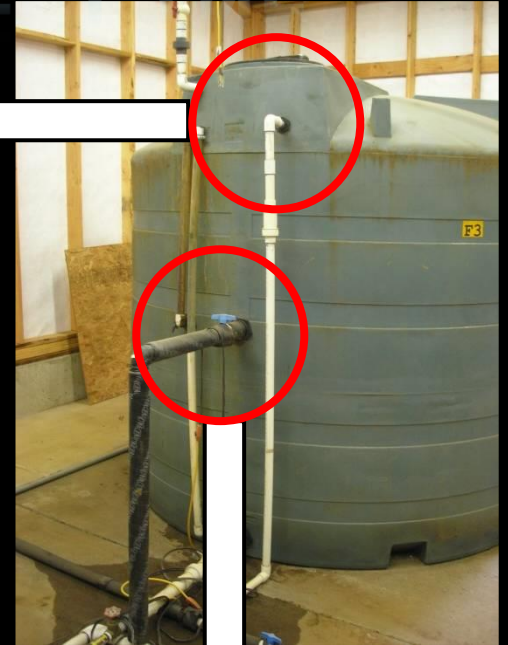
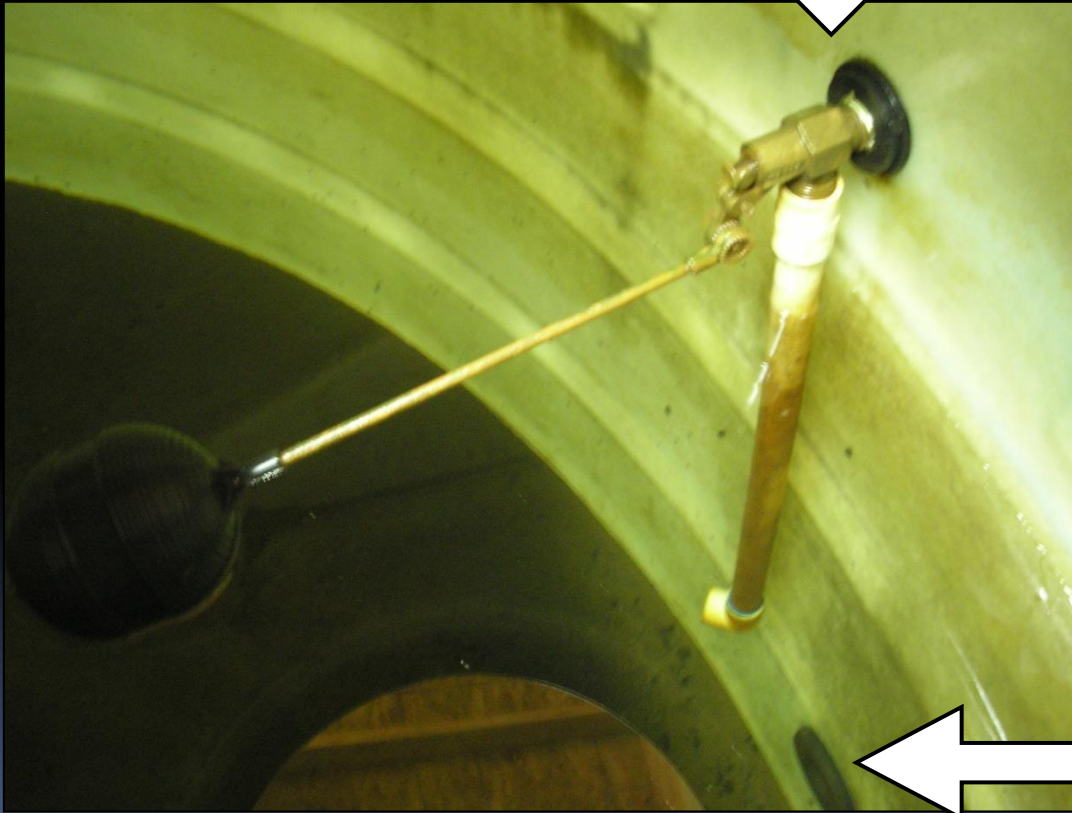

Harrowing
Valve &
Waste Line

HARROWING

Harrowing

As seen before, the schmutzdecke is different in covered filters



ENSURE ADEQUATE ACCESS

Access to Filters

Make sure ample room exists to enable cleaning. Protection from the elements not only facilitates cleaning operations, but also prevents freezing and longer ripening times.



2009. Jewell School District #8, OR. "Blue Future" covered filter (left) and raw water control tank (right)

SCRAPED VS HARROWING

Parameter	Scraped	Harrowed (wet harrowed)
Biomass Development	Biomass and schmutzdecke take longer to develop due to the removal of biomass	Biomass and schmutzdecke restore at a faster rate, however, the sudden release of nutrients can cause dissolved oxygen to dip as microbial grazing intensifies. Keeping influent water flowing and filtering to waste at a higher initial rate can help to replenish depleted oxygen levels.
Removal Efficiency	Equivalent once filter is properly ripened	Equivalent once a filter is properly ripened – usually takes less time to accomplish this.
Filter life	Impacted by removal of top ~2 cm of plugged sand layer	Little media loss leads to longer filter life. Media is more susceptible to deep bed clogging if not done properly.

FILTER RIPENING

1. Turbidity
2. Coliform Counts (CFU/100 ml)



Incubator

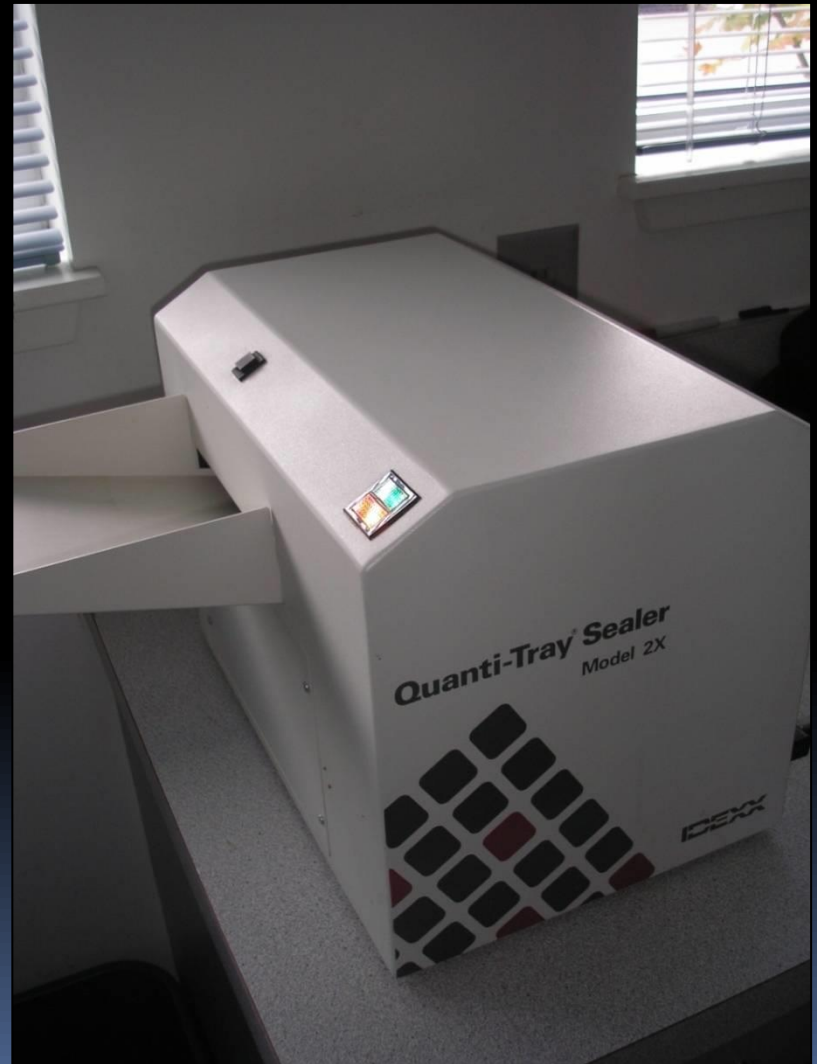

IDEXX Quanti-Tray Sealer

FILTER RE-SANDING

Two methods

1. Trenching or “throw-over” method
2. Full replacement



City of Astoria Re-sanding effort =>

FILTER RE-SANDING

Trenching or "throw-over" method:

1. Sand bed is cleaned (scraped or harrowed)
2. Most of the sand is removed and set aside for later reuse from a strip along one wall, forming a trench (underlying gravel is left undisturbed by leaving 4-6 inches (10-15 cm) of sand).
3. Fresh sand (either new or washed) is placed in the trench to a thickness, with the residual sand, equals the depth of the sand in the filter prior to re-sanding.
4. Residual sand from the next strip is "thrown over" on top of the freshly placed sand in the first strip.
5. This process is repeated until the last row. New sand is placed in the last row and the sand excavated from the first row is then placed on top of the new sand in the last row.

FILTER RE-SANDING

Trenching or "throw-over" method

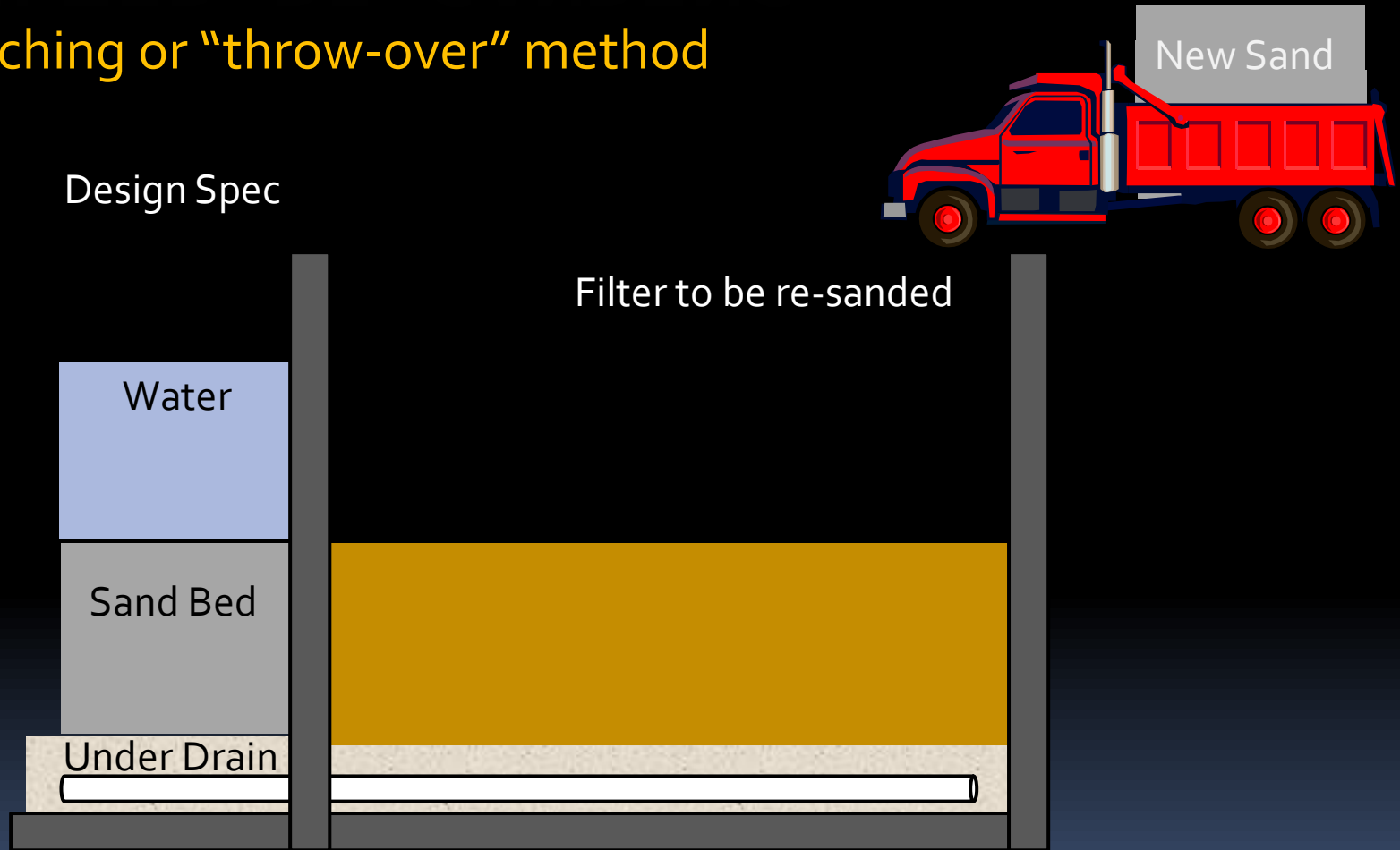

Note: Burying old sand under new sand can cause taste and odor issues as the biological material dies off and decays.

RIPENING OF RE-SANDED CELL

Ripening of newly sanded filters can take 3 or more weeks as evidenced by total coliform counts. Oftentimes it takes more than a month to wash out fines and ripen the filter.

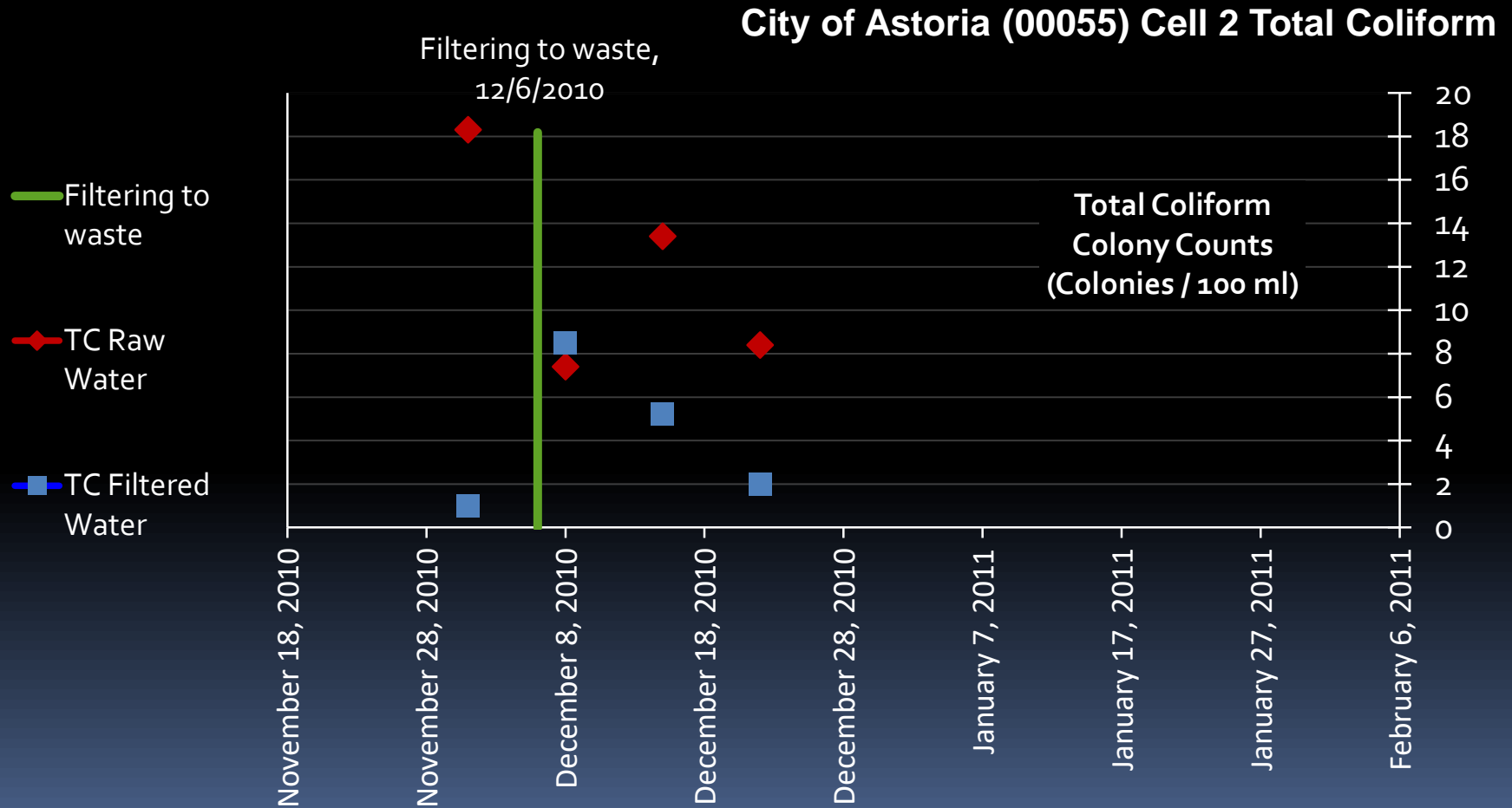

RIPENING OF RE-SANDED CELL

HISTORICAL PERFORMANCE

JANUARY 2010 – NOVEMBER 2010

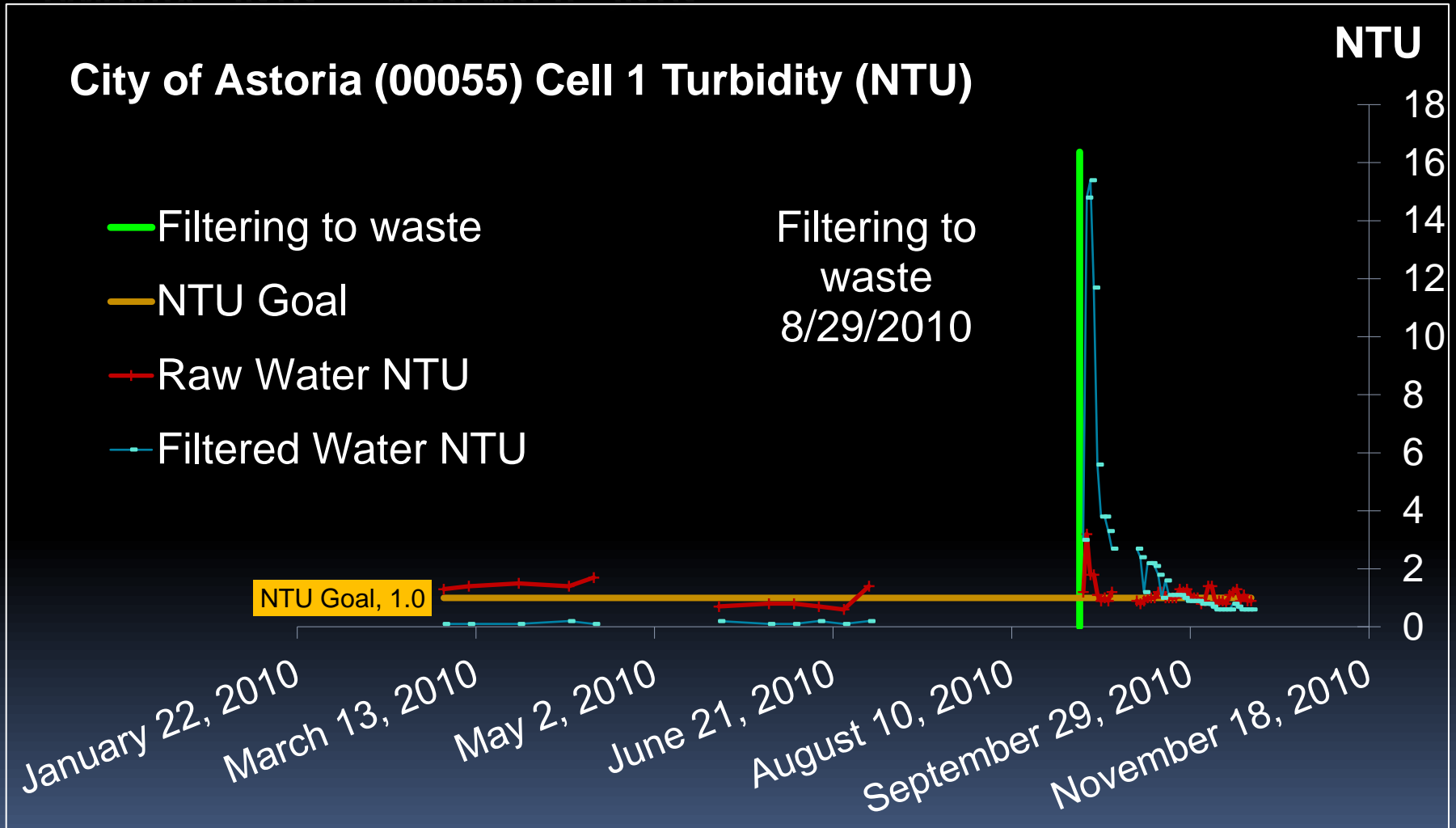

RIPENING RE-SANDED CELL

PERFORMANCE AFTER RE-SANDING

AUGUST 2010 – OCTOBER 2010

City of Astoria (00055) Cell 1 Turbidity (NTU)

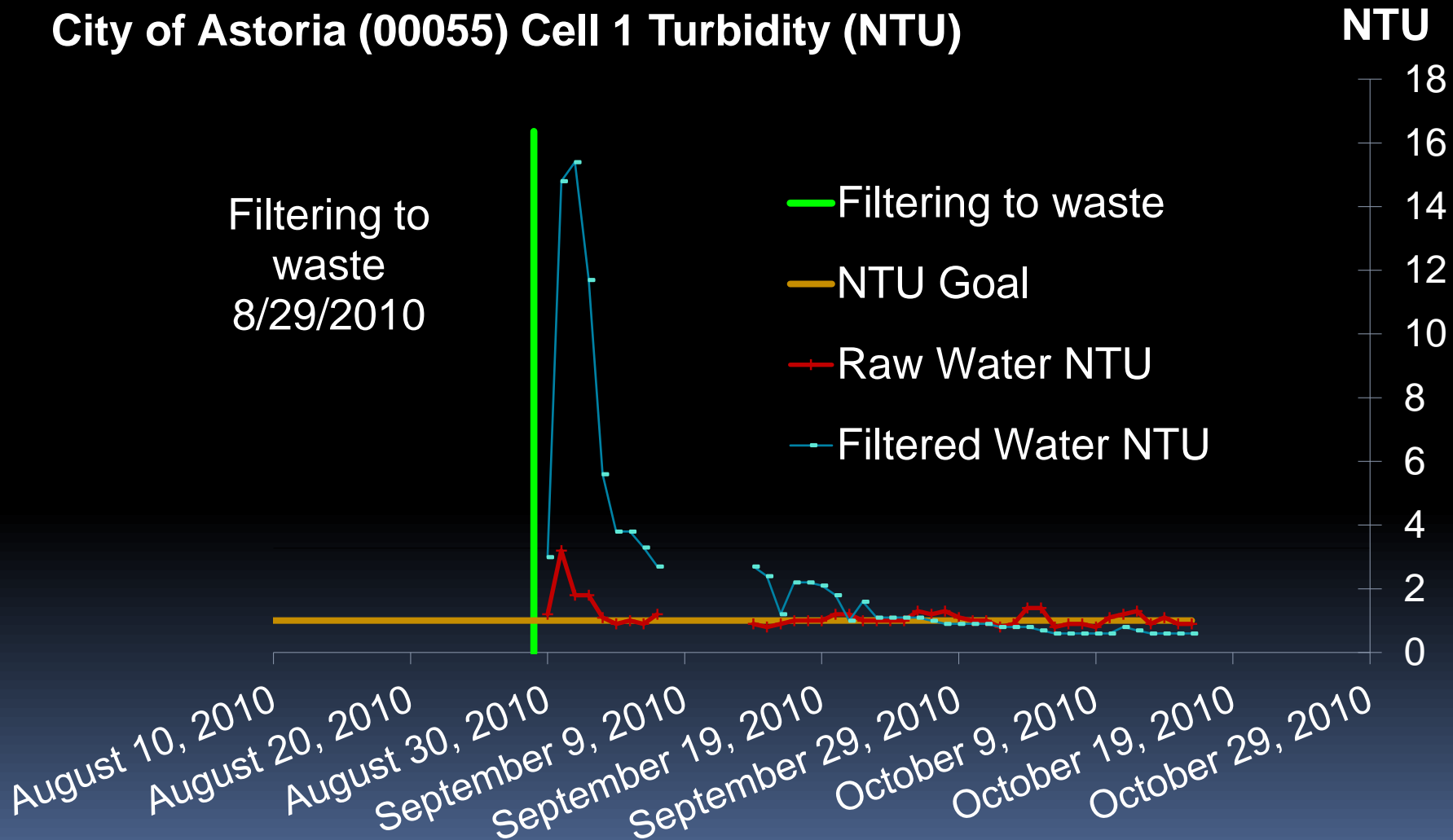

NEED FOR OPTIMIZATION GOALS & PRACTICES

1. Misunderstood removal mechanisms
2. Used in small communities (limited resources/expertise)
3. Turbidity is not a good indicator of filter performance
4. Good operating practices are the key to optimal performance
5. Goals were developed through literature review and comments received from experts in the field.

KEY PUBLICATIONS - 1974

"Slow Sand Filtration", World Health Organization, 1974 ISBN 92-4-154037-0
http://www.who.int/water_sanitation_health/publications/ssf9241540370.pdf

SLOW SAND FILTRATION

L. HUISMAN

*Professor of Sanitary Engineering, Department of Civil Engineering,
Technological University, Delft, Netherlands*

W.E. WOOD, F.I.C.E.

*formerly Chief, Community Water Supply,
World Health Organization, Geneva*



WORLD HEALTH ORGANIZATION

GENEVA

1974

KEY PUBLICATIONS - 1987

Raman, A., Paramasivam, R., Heijnen, H.A. and Visscher, J.T., 1987. *Slow sand filtration for community water supply : planning, design, construction, operation and maintenance.* (Technical paper series / IRC; no. 24). The Hague, The Netherlands: IRC International Water and Sanitation Centre.

<http://www.irc.nl/docsearch/title/108720>

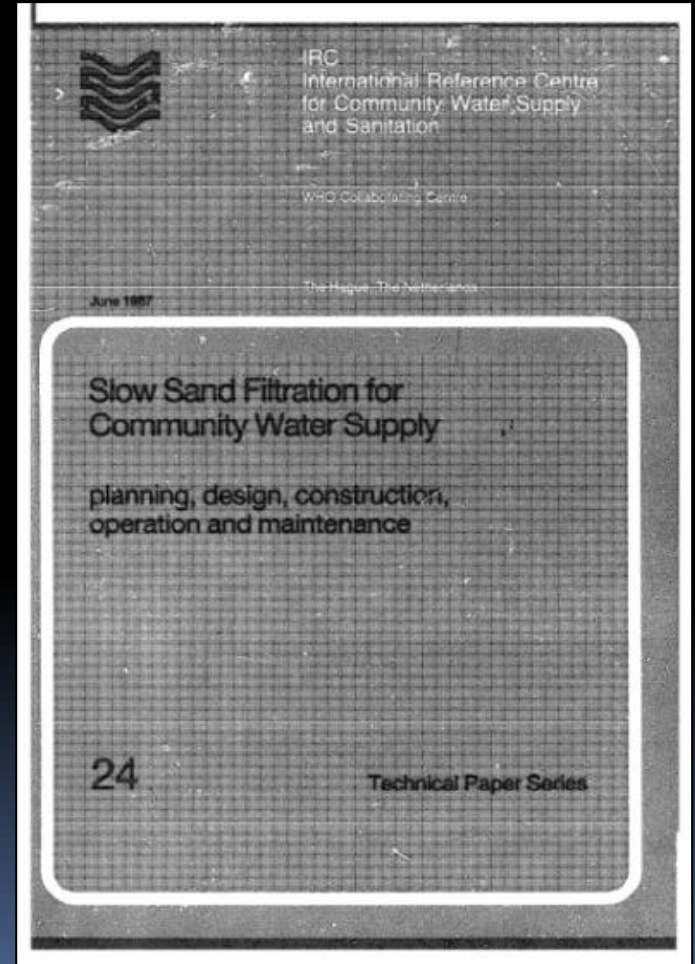

KEY PUBLICATIONS - 1991

“Manual of Design for Slow Sand Filtration” . David Hendricks.
American Water Works Association,
1991. ISBN 978-0898675511

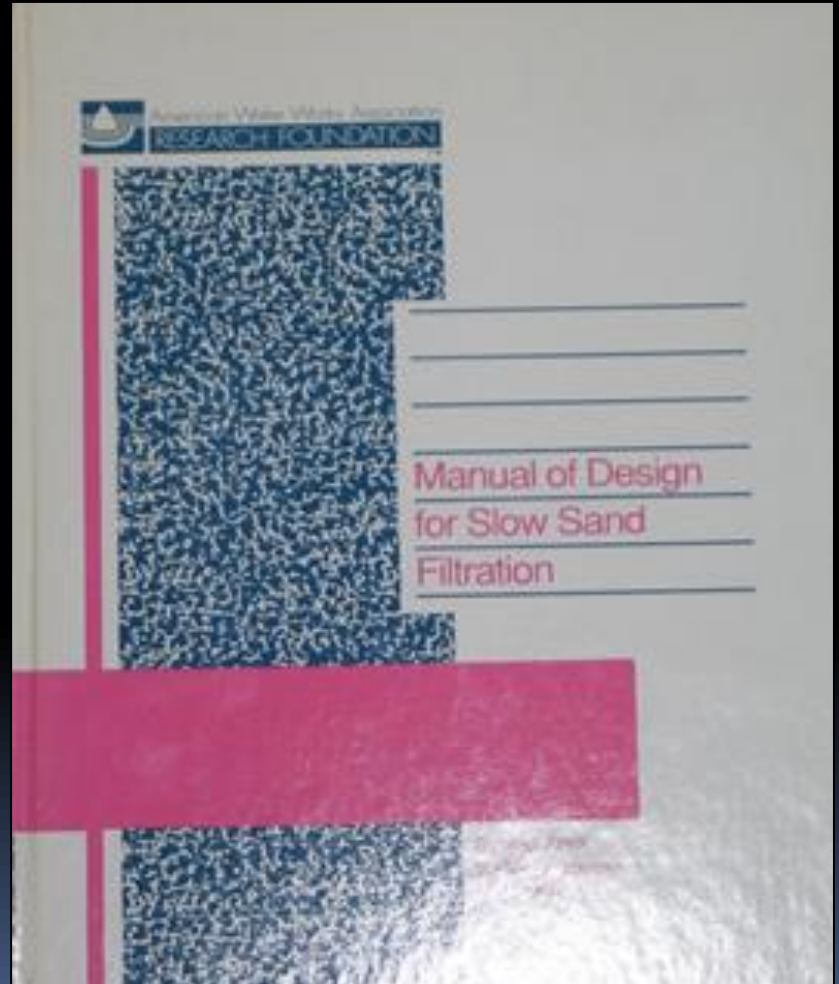

KEY PUBLICATIONS - 2009

“Technical Guidelines for the Construction and Management of Slow Sand Filters”. UNICEF, 2009.

<http://www.bsf-south-sudan.org/sites/default/files/SS+Tech+Guide--Slow+Sand+Filters.pdf>

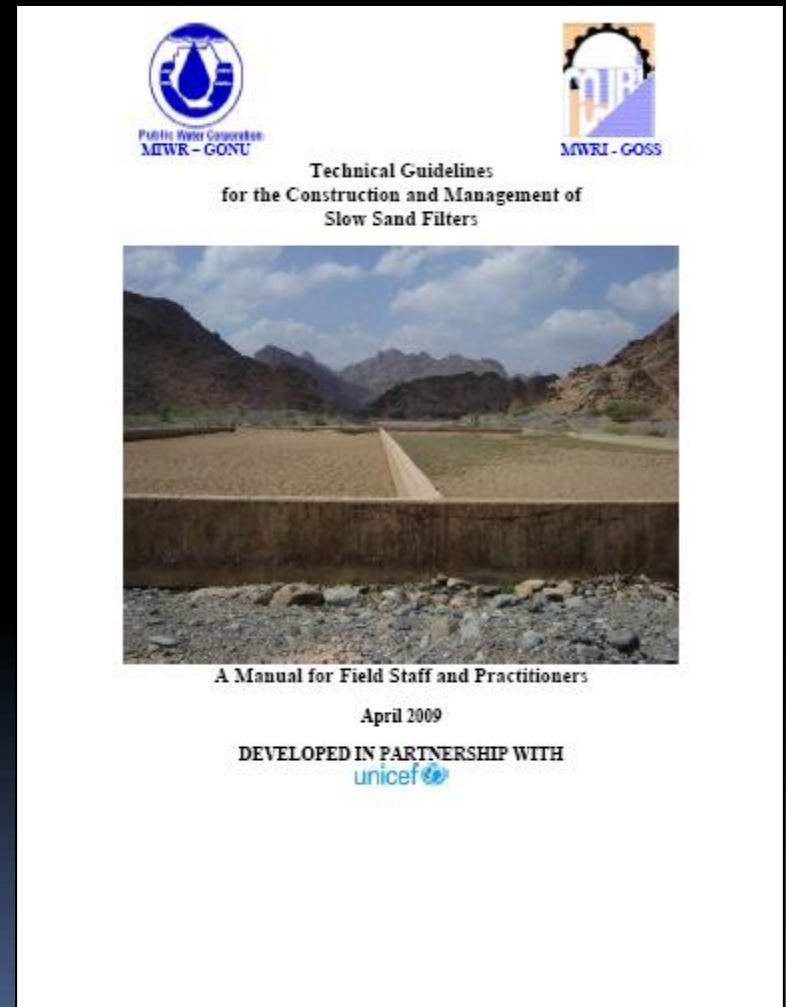

KEY PUBLICATIONS - 2012

“Water Treatment Plant Design, 5th Edition”. Stephen J. Randtke, Ph.D., P.E.; Michael B. Horsley, P.E. Co-published by the American Water Works Association; Environmental and Water Resources Institute of American Society of Civil Engineers; McGraw-Hill Professional. 2012. ISBN: 9780071745727

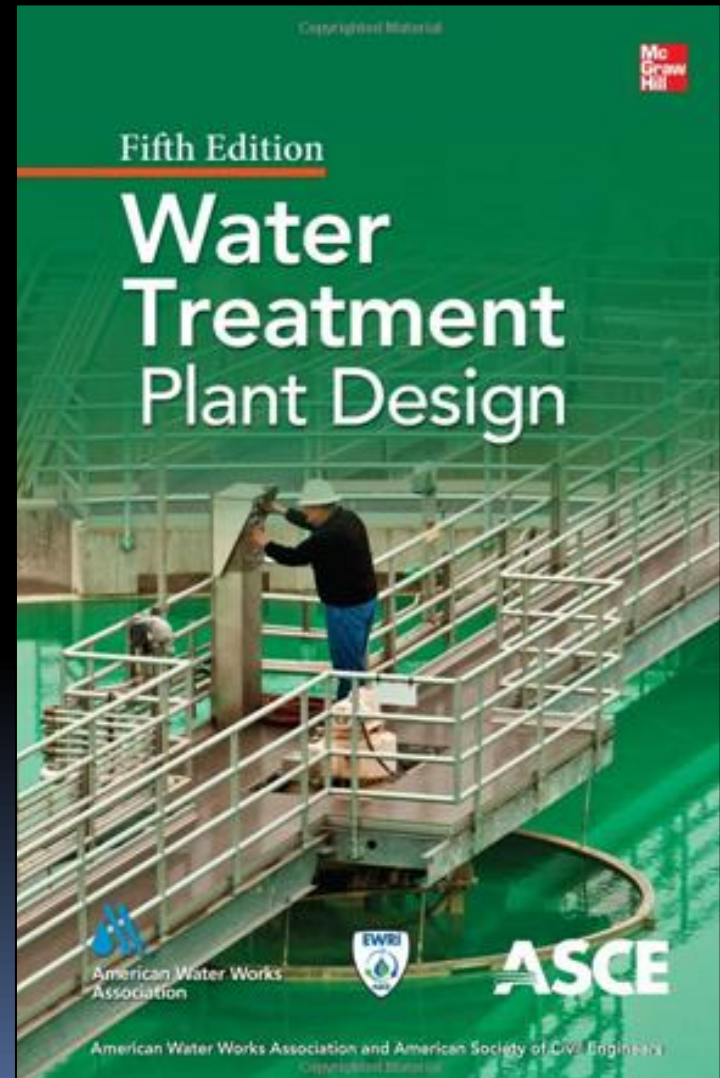

INPUT FROM EXPERTS

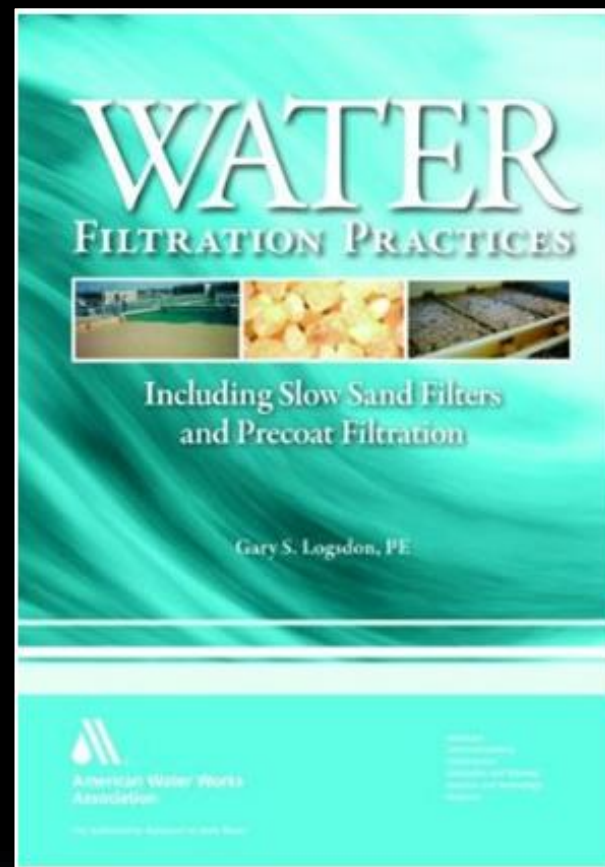
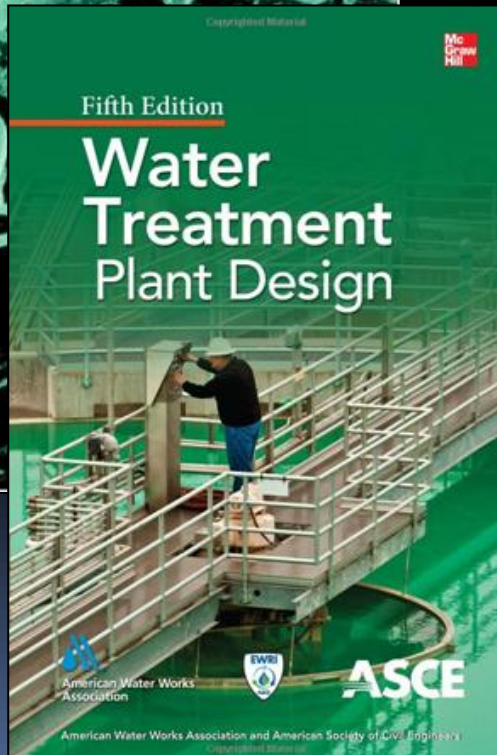

Gary S. Logsdon, P.E.

<= Dr. Robin Collins

INPUT STATE EXPERT STAFF

Slow Sand Filtration

Optimization Workshop
Region 10 AWOP

Steve Tanner
DEQ CDA Regional Office
March 3, 2010
Portland, Oregon



Stephen Tanner, Idaho DEQ



Stephen Baker
Washington
DOH



OPERATIONAL GUIDELINES

Operational Guidelines for Normal Operation

Operate slow sand filters continuously without filter effluent flow rate changes. If filter effluent flow changes are needed, ensure that the flow changes are made gradually to minimize detachment of particles from the sand with no more than a 50% variation in flow in a 24-hr period. Use filter effluent flow controls to accommodate changes in system demands (e.g., set the filtration rate high enough to meet anticipated peak day demands and divert excess water to waste or filter headwater influent during low demand periods). Intermittent operation of slow sand filters should not be used as a means of rate control.

Influent water should be introduced into the headwater at least 1-ft of clearance above the sand bed and filter walls.

Ensure filter effluent rates (Hydraulic Loading Rates, or HLR) of between 0.03 - 0.10 gpm/ft² (0.07 – 0.24 m/hr). Filtration rates may need to be lowered should raw water quality deteriorate with lower temperatures. A flow rate of 0.05 gpm/ft² may be used with water temperatures less than 5°C.

In order to prevent air binding within the filter, the tail water elevation must always be maintained at or above the level of the sand bed. Filtration rates and effluent weir levels should be routinely checked and adjusted only if needed.

OPERATIONAL GUIDELINES

FILTRATION RATE GUIDELINE

0.03 – 0.10 GPM/FT²

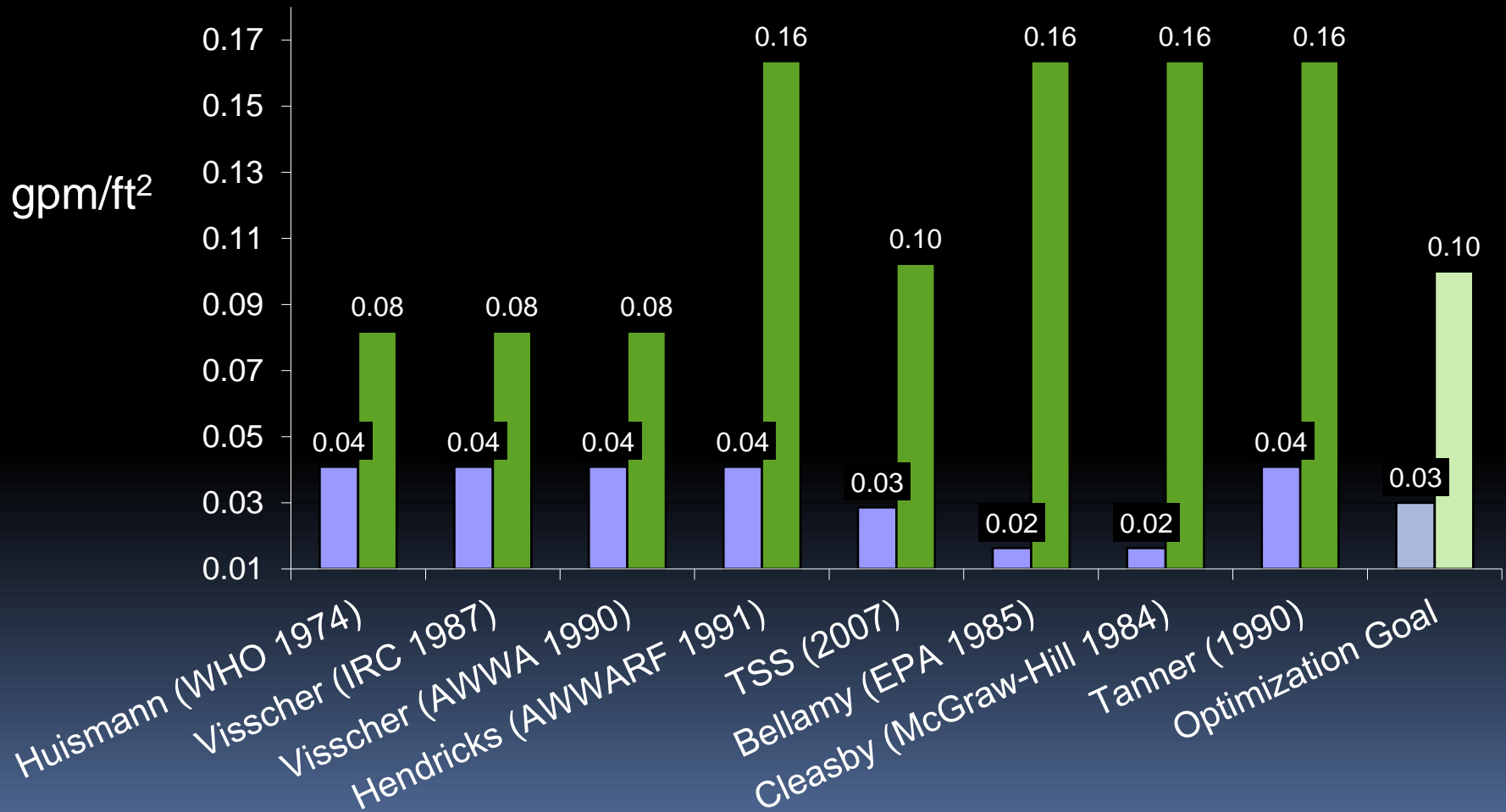

WATER QUALITY GOALS

Optimization Goals for Normal Operating Conditions

IFE & CFE Turbidity ≤ 1.0 NTU in 95% of the highest daily readings, measured at least once daily.

IFE & CFE Turbidity ≤ 5.0 NTU, measured at least once daily.

IFE Total Coliform ≤ 10 MPN/100 ml, measured at least weekly.

Water entering the distribution system is absent of total coliform bacteria (measure weekly when IFE or CFE turbidity > 1 NTU)

IFE = Individual Filter Effluent

CFE = Combined Filter Effluent

NTU = Nephelometric Turbidity Units

TC = Total Coliform, Most Probable Number (MPN) or Colony Forming Units (CFU) per Standard Methods.

WATER QUALITY GOALS

City of Salem, Oregon
Slow Sand Data
Jan 2006 – Dec 2010

NTU

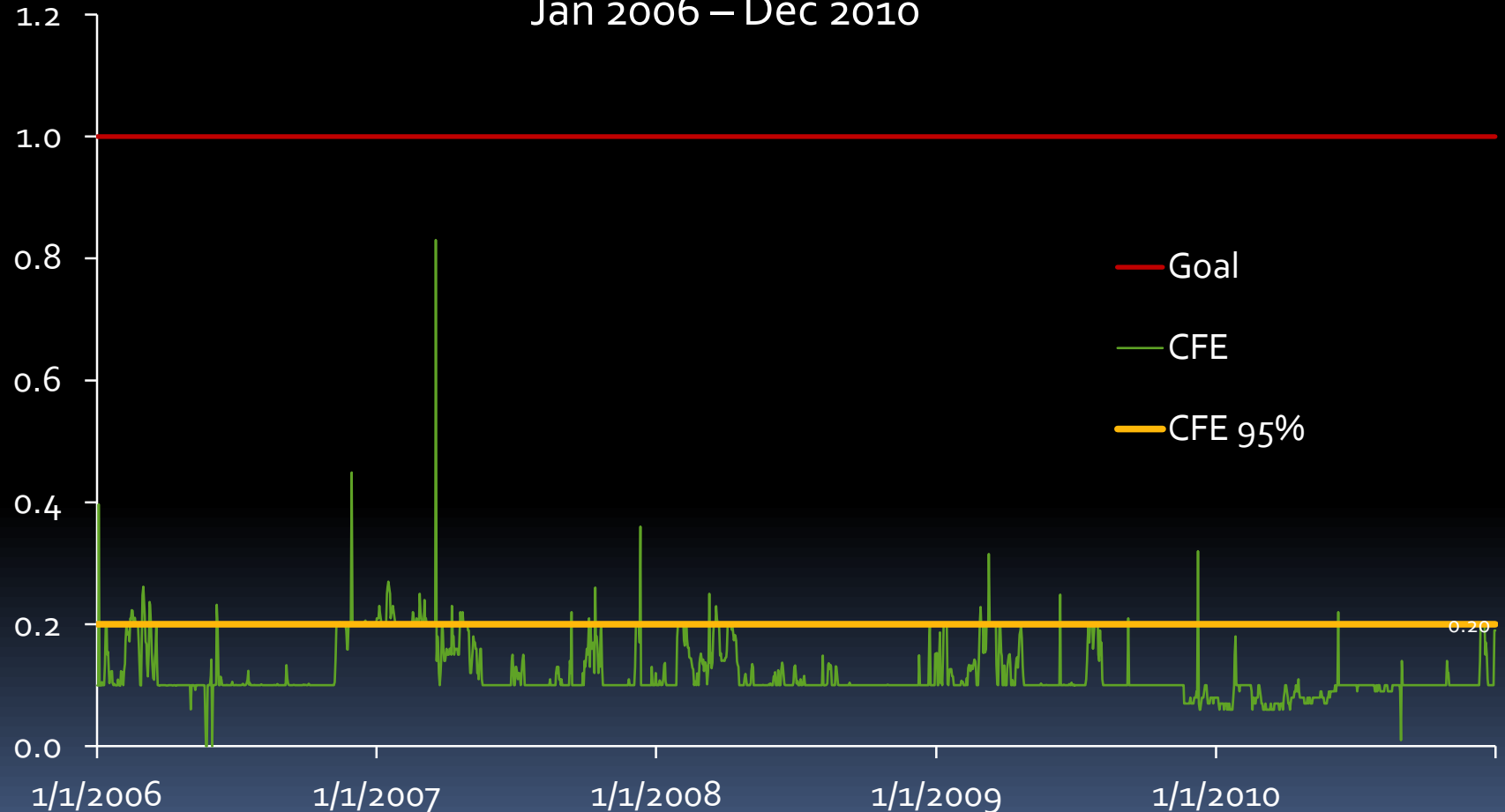

WATER QUALITY GOALS

Logan, Utah Full-Scale Research Slow Sand Plant

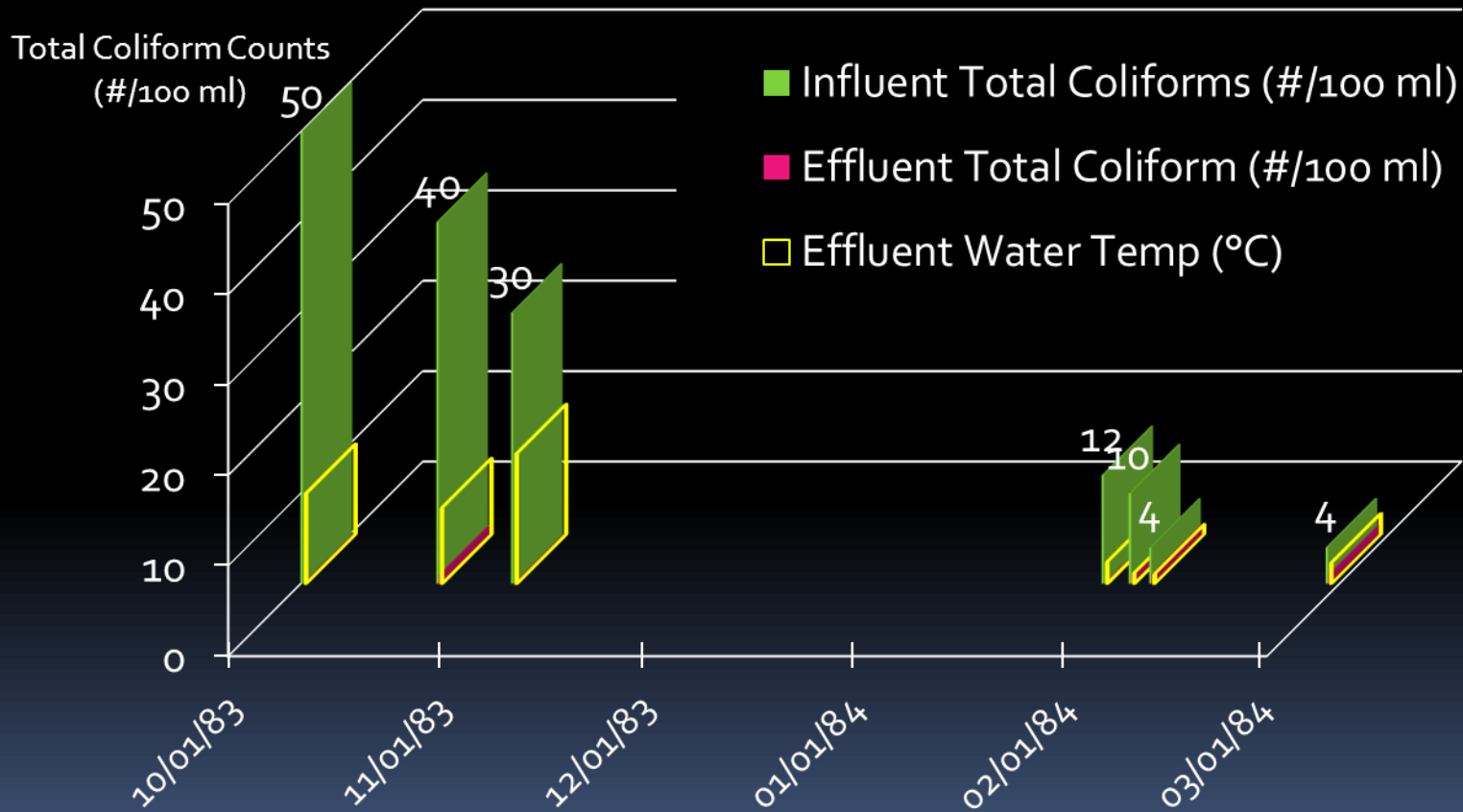

FILTER SCRAPING GUIDELINES



Operational Guidelines for Cleaning - Scraping

Scraping should be done when:

1. Headwater depth reaches the headwater overflow level;
2. The achievable filter production rate decreases to 0.03 gpm/ft^2 (0.073 m/hr); or
3. Daily demands are anticipated to not be met.

When removing a filter from service for cleaning, schedule the event to avoid overloading the remaining filters.

Minimize the time a de-watered filter is off-line.

Do not de-water the filter more than necessary in order to safely clean the filter (e.g. 2-12 inches below the sand surface).

FILTER SCRAPING GUIDELINES CONTINUED



Operational Guidelines for Cleaning - Scraping

Remove the schmutzdecke and no more than 1/4" - 1/2" (0.635-1.27 cm) of sand with each cleaning. Depending upon the effective size (d_{10}) and applied water quality, more sand may need to be scraped (1/2" - 1") in order to remove the plugged portion of the filter, allowing clean bed headloss to recover. Operators should monitor headloss before and after each scraping in order to determine how much sand is needed to be removed to maximize filter recovery while avoiding excessive sand removal. Monitoring headloss development by plotting daily headloss readings for each filter should be used to schedule filter cleanings during times of low demands and higher applied water temperatures (above 5°C). Scheduling cleanings during low systems demands will help ensure that demands are able to be met without overloading adjacent filters. Scheduling cleanings during times of warmer water temperature will help minimize the adverse effects of cold temperatures on the filter biota. The minimum permissible sand bed depth should be no less than 20-24 inches.

FILTER SCRAPING GUIDELINES CONTINUED



Operational Guidelines for Cleaning - Scraping

Remove the schmutzdecke and no more than $\frac{1}{4}$ - $\frac{1}{2}$ inch (0.635 – 1.27 cm) of sand with each cleaning. Keep the sand bed to within a minimum of 20 – 24 inches in depth.

Avoid walking or driving directly on the schmutzdecke during cleaning.

After the filter has been cleaned, slowly refill the filter from the bottom at a rate of 0.3-0.6 ft of bed depth per hour (0.1 – 0.18 m/hr or 0.0374 – 0.0748 gpm/ft²) in order to purge entrained air. Refill with non-chlorinated filtered water from one of the other filters until the headwater is 1-ft above the sand to minimize scouring of the sand bed when filling from the top begins. Then fill from the top at a rate that minimizes disturbing the sand bed.

Note: To convert ft/hr to gpm/ft², multiply (ft/hr) by (1 hr/60 min) and then multiply by (7.48 g/ft³). Example: 0.3 ft/hr x (1 hr/60 min) x (7.48 gpm/ft³) = 0.0347 gpm/ft².

FILTER SCRAPING GUIDELINES CONTINUED



Operational Guidelines for Cleaning - Scraping

Begin filtering to waste at the same rate as was used prior to cleaning, or at the anticipated rate needed when the filter is brought back on-line. Do not exceed the design flow rate and keep the rate ≤ 0.1 gpm/ft².

Filter to waste one hour for each hour that the filter is off-line, but for no less than 24 hours. Filter to waste until the optimization goals following filter cleaning have been met.

FILTER SCRAPING GUIDELINES

MINIMUM SAND DEPTH GUIDELINE 20 - 24 INCHES

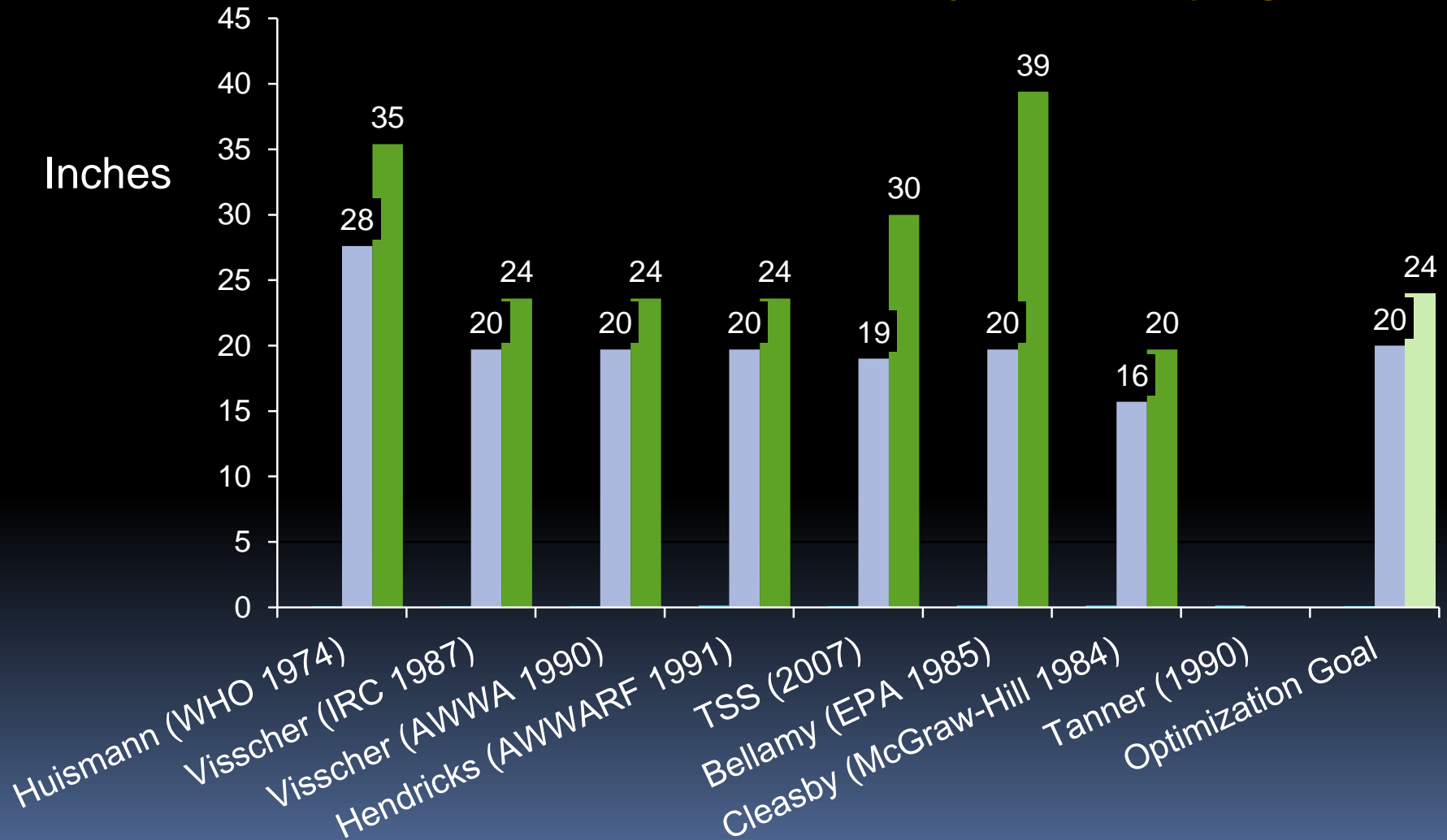

FILTER HARROWING GUIDELINES

Operational Guidelines for Cleaning - Harrowing

Lower water level to the level of the harrowing waste valve (e.g., about 6" (15 cm) above the sand bed). This is done to keep the head pressure low in order to minimize migration of debris down into the filter during the raking process.

Open the harrowing waste valve and begin introducing filtered unchlorinated water from the bottom of the filter at a rate of 0.16 ft/hr (0.02 gpm/ft²) and low enough to prevent the sand from being fluidized. This serves to suspend debris, and keeps it from settling back into the filter bed during raking.

Introduce water into the top of the filter at a rate low enough to prevent sand migration, but high enough to flush the debris to waste during raking. For rectangular filters, a typical flow rate of about 20 gpm times the depth of water above the sand during harrowing times the length of the filter that is perpendicular to the incoming flow will work. For example, 1,000 gpm will work with 6 inches of water depth in a 100-ft wide filter provided the flow path is directed across the width of the filter. For other filters, influent flow should be adjusted to maintain a steady water level above the sand during raking. In either case, it is important to maintain a constant water level above the sand throughout the harrowing process by balancing flows into and out of the filter.

Using a stiff tined rake or harrowing equipment, gently agitate the top 2 – 3" (5 – 8 cm) of sand until the headwater begins to clarify, as indicated by the ability to see the sand bed when the raking is stopped.

FILTER HARROWING GUIDELINES

Operational Guidelines for Cleaning - Harrowing

After it has been cleaned, slowly refill the filter from the bottom at a rate of 0.3-0.6 ft of rise per hour (0.1 – 0.18 m/hr or 0.0374 – 0.0748 gpm/ft²) in order to purge entrained air. Refill with non-chlorinated filtered water from one of the other filters until the headwater is 1-ft above the sand to minimize scouring of the sand bed when filling from the top begins. Then fill from the top at a rate that minimizes disturbing the sand bed.

Note: To convert ft/hr to gpm/ft², multiply (ft/hr) by (1 hr/60 min) and then multiply by (7.48 g/ft³). Example: 0.3 ft/hr x (1 hr/60 min) x (7.48 gpm/ft³) = 0.0347 gpm/ft².

Begin filtering to waste at the same rate as was used prior to cleaning, or at the anticipated rate needed when the filter is brought back on-line. Do not exceed the design flow rate and keep the rate ≤ 0.1 gpm/ft².

Filter to waste one hour for each hour that the filter is off-line, but for no less than 24 hours. Filter to waste until the optimization goals following filter cleaning have been met.

FILTER RIPENING GUIDELINES

Optimization Goals Following Filter Cleaning (scraping or harrowing)

Filter to waste for each hour that the filter is off-line, but no less than 24 hours, until sampling demonstrates that the goals below have been met

Filter not to be brought on-line until:

IFE TC \leq 5/100 ml (MPN or CFU)

(sample no earlier than 24 hours after the start of filtering to waste)

IFE NTU \leq 1.0 NTU

IFE = Individual Filter Effluent

CFE = Combined Filter Effluent

NTU = Nephelometric Turbidity Units

TC = Total Coliform, Most Probable Number (MPN) or Colony Forming Units (CFU)

FILTER RIPENING GUIDELINES

“Scraping invariably reduces a filter’s ability to remove *E. coli*.”
(Unger & Collins, 2008)

“Total coliform was the most suitable surrogate...borne out by data in which there was the closest correspondence between removals of total coliform and *Giardia* cysts [and serves as] an index that the filter is biologically mature”. (Hendricks, 1984)

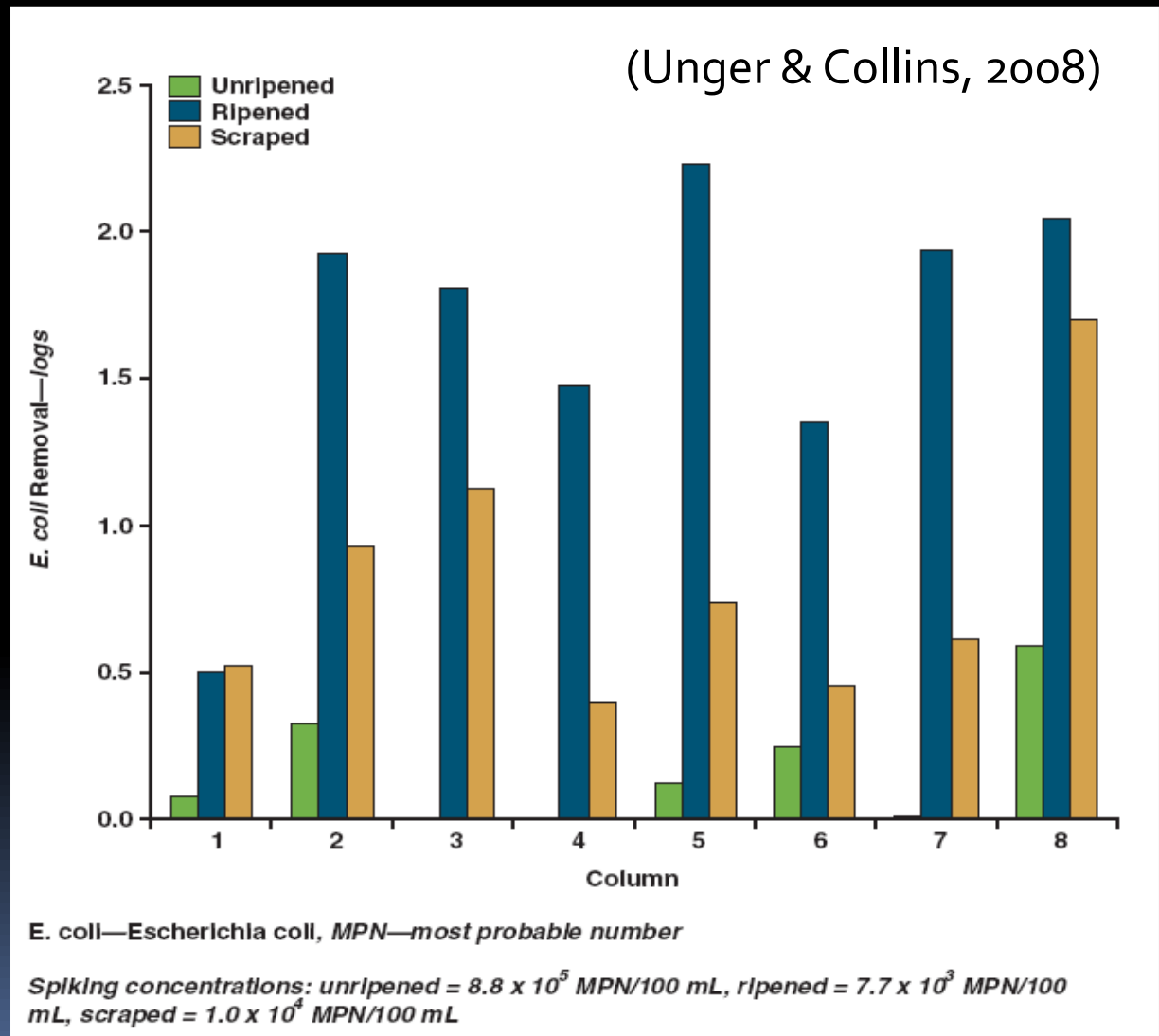

RECOMMENDED MEDIA SPECS FOR RE-SANDING

Silica Filter Sand Specification	Recommended Range
Effective Diameter (d10)	0.2 – 0.35 mm
Uniformity Coefficient (U)	1.5 – 3.0
% fines passing #200 sieve	< 0.3% by Wt.
Acid Solubility	< 5%
Apparent Specific Gravity	≥ 2.55
Minimum Depth	20-24 inches
Delivery/Installation	Sand should be washed prior to installation
NSF-61	Certified or equivalent

OPERATION & MAINTENANCE MANUAL

An O&M Manual should include procedures for...

1. Determining filtration rate
2. Changing filtration rate
3. Determining when to clean filters
4. Draining and refilling filters
5. Cleaning (scraping/harrowing)
6. Assuring adequate filter ripening
7. Dealing with seasonal changes
(e.g., cold winters, high NTU, algae blooms, etc.)
8. Determining sand bed depth and when to re-sand
9. Re-sanding (including media specifications and handling)
10. Maintaining/operating disinfection system



O&M MANUALS



Other procedures include:

- Instrument calibration methods and frequency
- Data handling/reporting
(Monitoring for regulatory requirements and process control)
- Chemical dosage determinations
- CT determinations
- Responding to abnormal conditions (emergency response plan)

MAINTENANCE TASKS

Frequency	Labor (person hours)	Slow Sand Filter Maintenance Task
Daily	1 - 3	Check raw water intake Check/adjust filtration rate Check water level in filter Check water level in clear well Sample & check water quality (raw/finished NTU, raw temp) Check pumps Enter observations in logbook
Weekly	1 - 3	Check & grease any pumps & moving parts Check/re-stock fuel Sample & check water quality (coliform) Enter observations in logbook
1 – 2 months	5 / 1,000 ft ² 50 / 1,000 ft ² /12 inches of sand for re-sanding (Letterman & Cullen, 1985)	Scrape filter beds Wash scrapings & store retained sand Check & record sand bed depth Enter observations in logbook

MONITORING

The recommended minimum location points for recording and monitoring include:

Source water for:

- Turbidity
- Flow
- Temperature
- pH
- Grab sampling of coliform, TOC, or other water quality parameters

Supernatant for:

- Level (for filter headloss)
- Grab sampling of coliform, TOC, or other water quality parameters



MONITORING

Individual filter effluent for:

- Flow rate and quantity
- Turbidity
- Grab sampling of coliform, TOC, or other water quality parameters
- Pressure (for filter headloss)



Combined filter effluent for:

- Flow rate and quantity
- Turbidity
- Grab sampling of coliform, TOC, or other water quality parameters

Finished water (post disinfection and storage used for disinfection contact time) for:

- Flow rate and quantity
- pH
- Temperature
- Chlorine residual
- Grab sampling of coliform, TOC, or other water quality parameters



Finished water storage for:

- Effluent flows
- Level

COLIFORM COUNTS

1. Membrane Filtration (CFU/100 ml) – SM 9221A,B – exact count
2. Multiple-Tube Fermentation (MPN/100 ml) – SM 9222A,B,C – statistical estimate
3. ONPG-MUG Test or “Autoanalysis Colilert” (MPN/100 ml) – SM 9223 – estimate

Most Probable Number (MPN/100 ml)

(both examples below use statistical MPN)

Multiple-tube fermentation (MTF)

(e.g., 10-tube Standard Methods MTF)

- Test tubes (20 x 150 mm)
- Culture media (e.g., R2A agar)
- Scale to measure media
- Autoclave to sterilize media
- Incubator
- Formation of gas first indicates presumptive positive results, which are then confirmed

IDEXX Quanti-Tray and Quanti-Tray/2000

- Quanti-Tray Sealer & Incubator (35°C)
- IDEXX Quanti-Tray Range: 1-200 CFU/100 ml (95% confidence)
- IDEXX Quanti-Tray/2000 Range: 1 – 2,419 CFU/100 ml (95% confidence)
- Ortho-nitrophenyl-β-galactopyranoside (ONPG) reagent
- 4-methylumbelliferyl-β-D-glucuronide (MUG) - only *E.coli* produce an enzyme that reacts with MUG

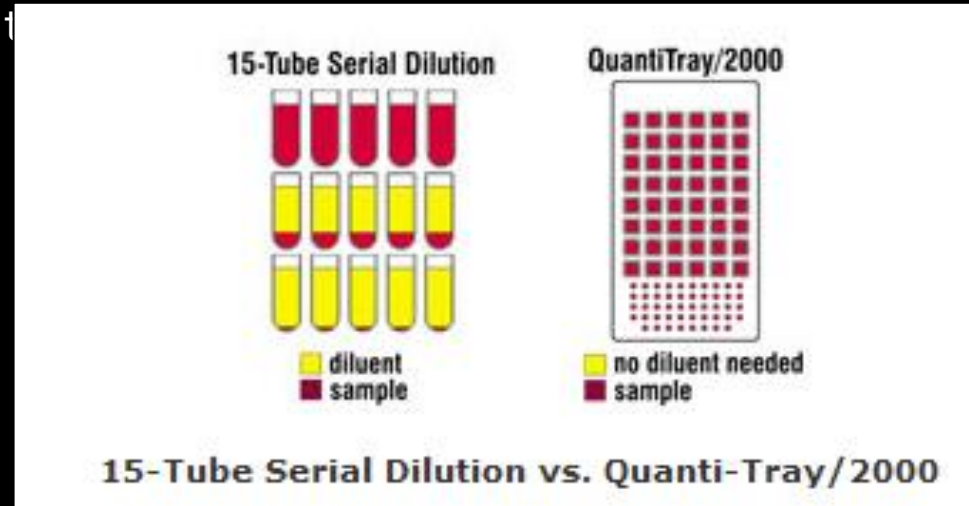

COLIFORM COUNTS

1. Membrane Filtration (CFU/100 ml) – SM 9221A,B – exact count
2. Multiple-Tube Fermentation (MPN/100 ml) – SM 9222A,B,C – statistical estimate
3. ONPG-MUG Test or “Autoanalysis Colilert” (MPN/100 ml) – SM 9223 - estimate

Membrane Filtration (Colony Forming Units/100 ml)

- A sample of water is filtered through a membrane (0.22-0.45 μm pore size)
- Filter is removed and placed on growth medium (nutrients feed colony growth)
- Number of colonies are counted (each colony arises out of 1 coliform)

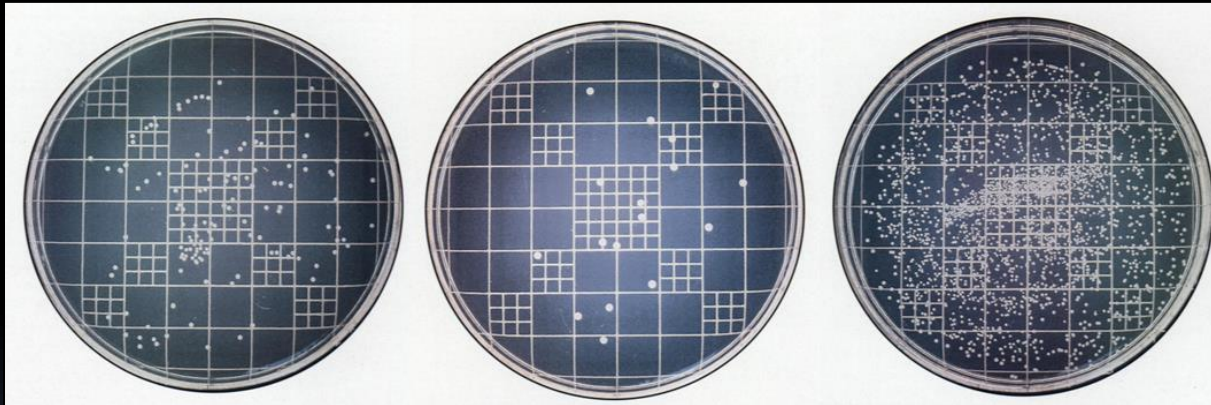

Photographs of plates with countable colonies (left), too few colonies to count (middle) and too numerous colonies to count (right). Colonies are the white circular forms and theoretically arise from a single cell called a colony forming unit.

(A Photographic Atlas for the Microbiology Laboratory. Michael J. Leboffe and Burton E. Pierce. 2nd Edition. Pp 83-85, Morton Publishing Co, Englewood, CO).

MULTIPLE-TUBE FERMENTATION (SM 9222 A,B,C)

1. Membrane Filtration (CFU/100 ml) – SM 9221A,B – exact count
2. Multiple-Tube Fermentation (MPN/100 ml) – SM 9222A,B,C – statistical estimate
3. ONPG-MUG Test or “Autoanalysis Colilert” (MPN/100 ml) – SM 9223 – estimate

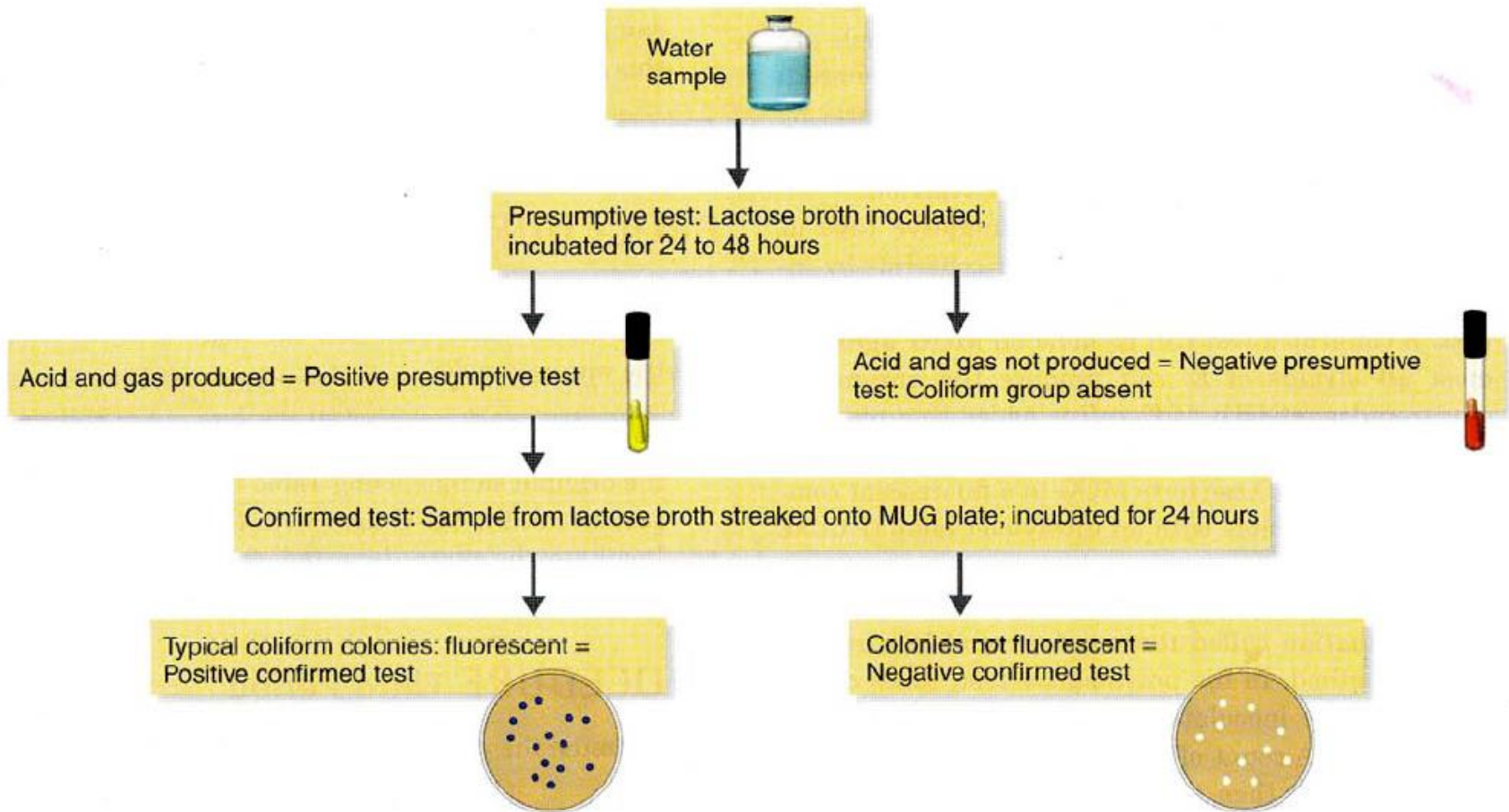

ONPG-MUG TEST. EXAMPLE: IDEXX COLILERT QUANTI-TRAY® (SM 9223 B)

1) Collect 100-ml sample



2) Added Colilert Reagent



3) Turn on Quanti-Tray Sealer



4) Add Sample to Quanti-Tray tray



5) Insert tray into sealer



6) Incubate at 35°C for 24 hrs (or 18-hrs with Colilert-18)



7) Count total coliform positive wells

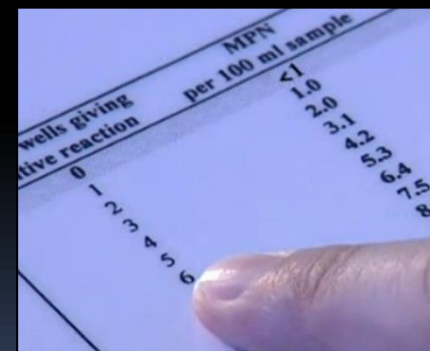
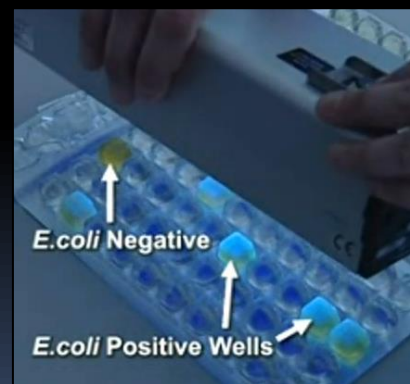

http://www.idexx.com/view/xhtml/en_us/water/products/quantitrays.jsf

8) Count fluorescent e-coli positive wells (use black light)

9) Use MPN table to determine MPN/100-mls

MONITORING HEAD LOSS

Head loss Measurement

On smaller facilities, routine visual observation of the supernatant depth and recording of the flow rate may be sufficient to monitor filter head loss development.

On larger facilities, screened probes at the top and bottom of the filter sand can allow easy measurement of head loss with simple **piezometers mounted outside the filter**, or through the use of a differential pressure transducer connected to the facility's SCADA system.

Tracking this data will allow the operator to predict and plan filter cleanings.

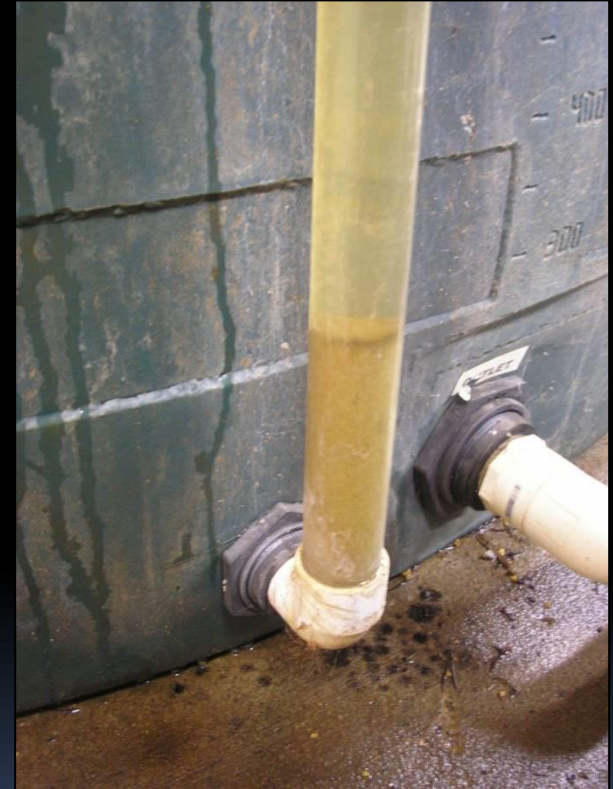

QUESTIONS ABOUT OPERATIONS?



Wickiup Water District, Oregon