

OREGON MILITARY DEPARTMENT	NUMBER: AGP-99.200.10
ADJUTANT GENERAL PERSONNEL	EFFECTIVE DATE: July 1, 2020
SUBJECT: Ladder Policy	

APPLICABILITY:

This policy and the procedures contained herein are applicable to state employees.

AUTHORITY/REFERENCE:

OAR 437-002-0026, OAR 437-004-0340, 29 CFR 1910.23

PURPOSE:

To ensure that OMD employees and contractors use ladders in a safe manner and in compliance with this policy.

RESPONSIBILITIES:

It is the responsibility of every employee who uses a ladder for work purposes and every supervisor of those employees to ensure that ladders are safe to be used and are used according to the guidelines set forth in this policy.

Ladders affixed to buildings and used for roof access and mechanical maintenance are responsibility of the building owner. Any defect or unsafe conditions must be reported immediately. The ladder will be flagged “as “CLOSED - Not To Be Used” until repairs are made.

GENERAL GUIDANCE:

The manager must ensure that each ladder used meets the requirements of this policy. This policy covers all ladders, except when the ladder is:

- Used in emergency operations such as firefighting, rescue, and tactical law enforcement operations, or training for these operations; or
- Designed into or is an integral part of machines or equipment.

General requirements for all ladders. The employer must ensure:

- Ladder rungs, steps, and cleats are parallel, level, and uniformly spaced when the ladder is in position for use.
- Ladder rungs, steps, and cleats are spaced not less than 10 inches and not more than 14 inches apart, as measured between the centerlines of the rungs, cleats, and steps, except that:

Ladder rungs and steps in elevator shafts must be spaced not less than 6 inches apart and not more than 16.5 inches apart, as measured along the ladder side rails; and

Fixed ladder rungs and steps on telecommunication towers must be spaced not more than 18 inches apart, measured between the centerlines of the rungs or steps;

Steps on stepstools are spaced not less than 8 inches apart and not more than 12 inches apart, as measured between the centerlines of the steps;

Ladder rungs, steps, and cleats have a minimum clear width of 11.5 inches on portable ladders and 16 inches (measured before installation of ladder safety systems) for fixed ladders, except that:

- The minimum clear width does not apply to ladders with narrow rungs that are not designed to be stepped on, such as those located on the tapered end of orchard ladders and similar ladders;
- Rungs and steps of manhole entry ladders that are supported by the manhole opening must have a minimum clear width of 9 inches;
- Rungs and steps on rolling ladders used in telecommunication centers must have a minimum clear width of 8 inches; and
- Stepstools have a minimum clear width of 10.5 inches;

Wooden ladders will not be coated with any material that may obscure structural defects;

Metal ladders are made with corrosion-resistant material or protected against corrosion;

Ladder surfaces are free of puncture and laceration hazards;

Ladders are used only for the purposes for which they were designed;

Ladders are inspected before initial use in each work shift, and more frequently as necessary, to identify any visible defects that could cause employee injury;

Any ladder with structural or other defects is immediately tagged “Dangerous: Do Not Use” or with similar language in accordance with OSHA 1910.145 and removed from service until repaired in accordance with OSHA 1910.22(d), or replaced;

Each employee faces the ladder when climbing up or down it;

Each employee uses at least one hand to grasp the ladder when climbing up and down it; and

No employee carries any object or load that could cause the employee to lose balance and fall while climbing up or down the ladder.

PORTABLE LADDERS:

Rungs and steps of portable metal ladders are corrugated, knurled, dimpled, coated with skid-resistant material, or otherwise treated to minimize the possibility of slipping;

Ladders are not loaded beyond the maximum intended load;

(Includes the total load (weight and force) of the employee and all tools, equipment, and materials being carried).

Ladders are used only on stable and level surfaces unless they are secured or stabilized to prevent accidental displacement;

No portable single rail ladders are used;

No ladder is moved, shifted, or extended while an employee is on it;

Ladders placed in locations such as passageways, doorways, or driveways where they can be displaced by other activities or traffic:

- Are secured to prevent accidental displacement; or
- Are guarded by a temporary barricade, such as a row of traffic cones or caution tape, to keep the activities or traffic away from the ladder;

The cap (if equipped) and top step of a stepladder are not used as steps;

Portable ladders used on slippery surfaces are secured and stabilized;

The top of a non-self-supporting ladder is placed so that both side rails are supported, unless the ladder is equipped with a single support attachment;

Portable ladders used to gain access to an upper landing surface have side rails that extend at least 3 feet above the upper landing surface;

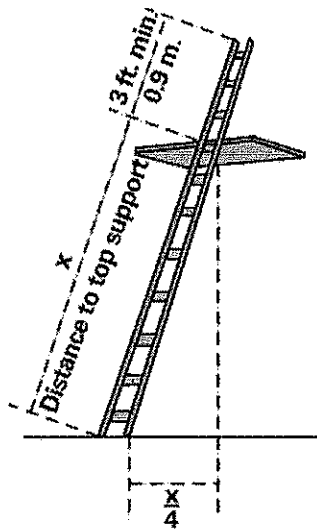

Ladders and ladder sections are not tied or fastened together to provide added length unless they are specifically designed for such use;

Ladders are not placed on boxes, barrels, or other unstable bases to obtain additional height;

Each self-supporting ladder or combination ladder used in self-supporting ladder mode must be equipped with a metal spreader or locking device that securely holds the front and back sections in a fully open position while the ladder is in use;

No employee steps, jumps or otherwise moves from one erected ladder to another;

Ladders are not used as planks or bridges between walking-working surfaces or in other horizontal applications;

Ladders are not used to gain additional height from elevated surfaces such as scaffolds, truck beds, vehicle bodies, tractor scoops or boom truck buckets;

Ladders are not to be used as supports for working platforms or scaffolding planks unless approved for such purposes by the ladder manufacturer;

FIXED LADDERS:

Before using, employees must ensure:

Fixed ladders must be capable of supporting their maximum intended load;

The minimum perpendicular distance from the centerline of the steps or rungs, or grab bars, or both, to the nearest permanent object in back of the ladder is 7 inches, except for elevator pit ladders, which have a minimum perpendicular distance of 4.5 inches;

Grab bars do not protrude on the climbing side beyond the rungs of the ladder that they serve;

The side rails of through or sidestep ladders extend 42 inches above the top of the access level or landing platform served by the ladder.

For parapet ladders, the access level is:

- The roof, if the parapet is cut to permit passage through the parapet; or
- The top of the parapet, if the parapet is continuous.

For through ladders, the steps or rungs are omitted from the extensions, and the side rails are flared to provide not less than 24 inches and not more than 30 inches of clearance. When a ladder safety system is provided, the maximum clearance between side rails of the extension must not exceed 36 inches;

For side-step ladders, the side rails, rungs, and steps must be continuous in the extension:

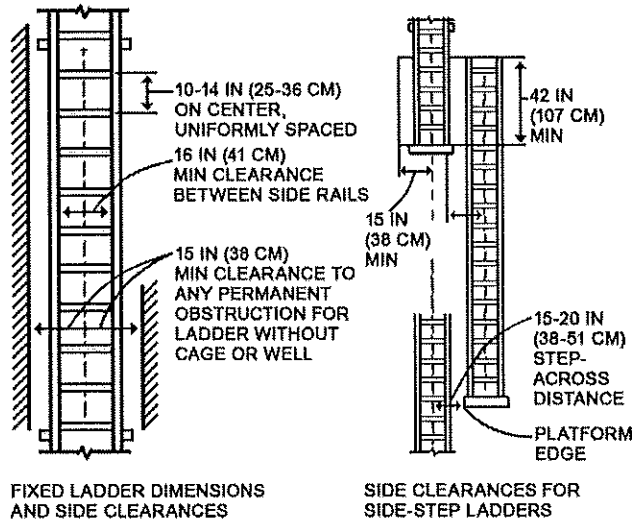

Grab bars extend 42 inches above the access level or landing platforms served by the ladder;

The minimum size (cross-section) of grab bars is the same size as the rungs of the ladder;

When a fixed ladder terminates at a hatch (see Figure below), the hatch cover:

- Opens with sufficient clearance to provide easy access to or from the ladder; and
- Opens at least 70 degrees from horizontal if the hatch is counterbalanced;

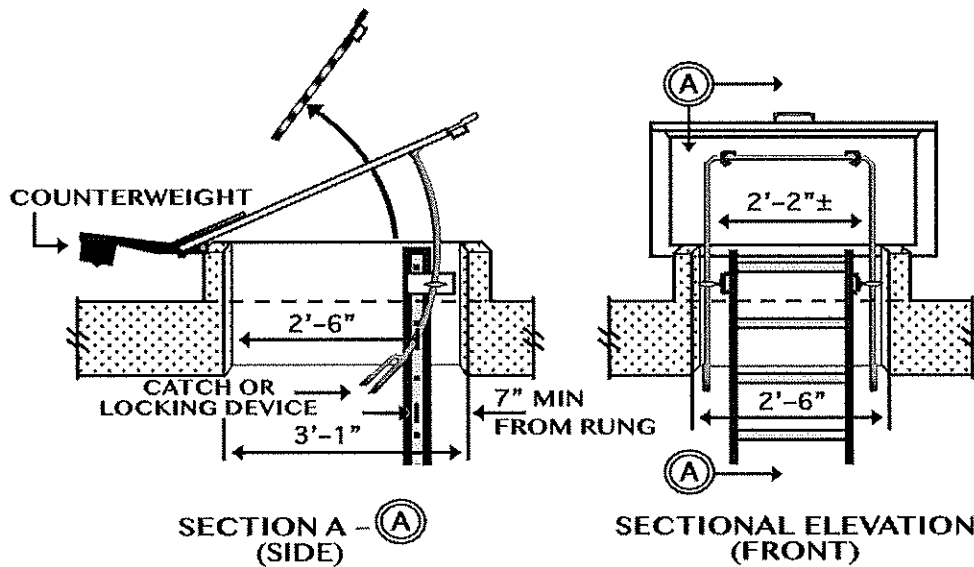

Individual-rung ladders are constructed to prevent the employee's feet from sliding off the ends of the rungs (see below);

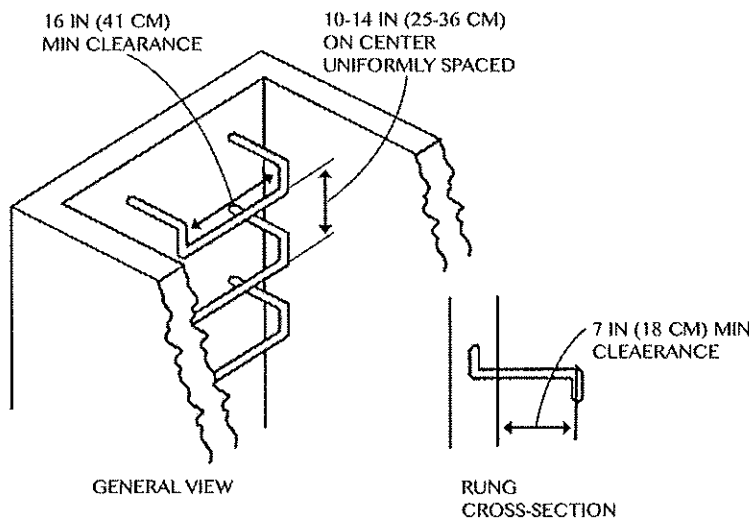

Fixed ladders having a pitch greater than 90 degrees from the horizontal are not used;

The step-across distance from the centerline of the rungs or steps is:

- For through ladders, not less than 7 inches and not more than 12 inches to the nearest edge of the structure, building, or equipment accessed from the ladders;
- For side-step ladders, not less than 15 inches and not more than 20 inches to the access points of the platform edge;

Fixed ladders that do not have cages or wells have:

- A clear width of at least 15 inches on each side of the ladder centerline to the nearest permanent object; and
- A minimum perpendicular distance of 30 inches from the centerline of the steps or rungs to the nearest object on the climbing side. When unavoidable obstructions are

encountered, the minimum clearance at the obstruction may be reduced to 24 inches, provided deflector plates are installed (see below).

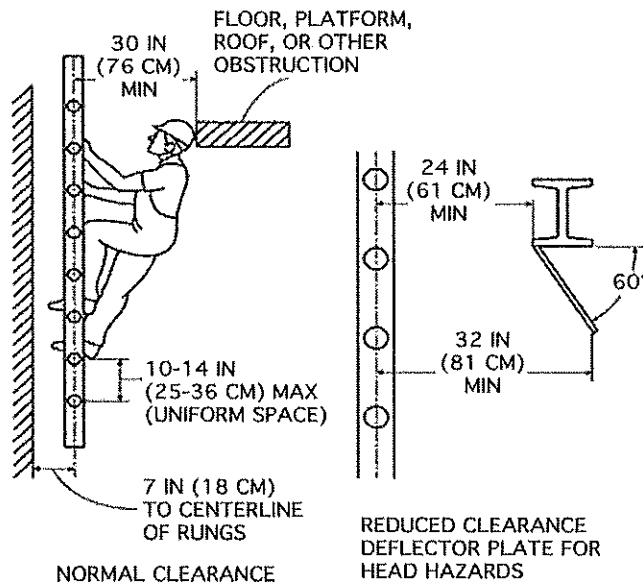

MOBILE LADDER STANDS AND MOBILE LADDER STAND PLATFORMS:

General requirements. The manager must ensure:

- Mobile ladder stands and platforms have a step width of at least 16 inches;
- The steps and platforms of mobile ladder stands and platforms are slip resistant; Slip-resistant surfaces must be either an integral part of the design and construction of the mobile ladder stand and platform, or provided as a secondary process or operation, such as dimpling, knurling, shotblasting, coating, spraying, or applying durable slip-resistant tapes;
- Mobile ladder stands and platforms are capable of supporting at least four times their maximum intended load;
- Wheels or casters under load are capable of supporting their proportional share of four times the maximum intended load, plus their proportional share of the unit's weight;
- Unless otherwise specified in this section, mobile ladder stands and platforms with a top step height of 4 feet or above have handrails with a vertical height of 29.5 inches to 37 inches, measured from the front edge of a step. Removable gates or non-rigid members, such as chains, may be used instead of handrails in special use applications;
- The maximum work-surface height of mobile ladder stands and platforms does not exceed four times the shortest base dimension, without additional support. For greater heights, outriggers, counterweights, or comparable means that stabilize the mobile ladder stands and platforms and prevent overturning must be used;
- Mobile ladder stands and platforms that have wheels or casters are equipped with a system to impede horizontal movement when an employee is on the stand or platform;
- and
- No mobile ladder stand or platform moves when an employee is on it.

DESIGN REQUIREMENTS FOR MOBILE LADDER STANDS:

The manager must ensure:

- Steps are uniformly spaced and arranged, with a rise of not more than 10 inches and a depth of not less than 7 inches. The slope of the step stringer to which the steps are attached must not be more than 60 degrees, measured from the horizontal;
- Mobile ladder stands with a top step height above 10 feet have the top step protected on three sides by a handrail with a vertical height of at least 36 inches; and top steps that are 20 inches or more, front to back, have a midrail and toeboard. Removable gates or non-rigid members, such as chains, may be used instead of handrails in special-use applications; and
- The standing area of mobile ladder stands is within the base frame;
- Steps of mobile ladder stand platforms meet the requirements listed above in the first paragraph under the heading of Design Requirements for Mobile Ladder Stands. When the employer demonstrates that the requirement is not feasible, steeper slopes or vertical rung ladders may be used, provided the units are stabilized to prevent overturning;
- Mobile ladder stand platforms with a platform height of 4 to 10 feet have, in the platform area, handrails with a vertical height of at least 36 inches and midrails;
- All ladder stand platforms with a platform height above 10 feet have guardrails and toeboards on the exposed sides and ends of the platform; and
- Removable gates or non-rigid members, such as chains, may be used on mobile ladder stand platforms instead of handrails and guardrails in special-use applications.

INQUIRIES/QUESTIONS: Questions pertaining to this guidance may be directed to AGP at (503) 584-3588.



Tracy Garcia
Adjutant General Personnel
Oregon Military Department