

Updating the Archaeological Field Guidelines Placeholder

With the July 1, 2023 implementation start for the revised rule governing the issuance of archaeological permits (Oregon Administrative Rule [OAR] 736-051-0000 to 0090), the current Guidelines for Conducting Field Archaeology in Oregon (Field Guidelines) need updating. At present, the update is scheduled for late fall or winter of 2023-24. In the meantime, the placeholder for the update addresses things to consider in the existing Field Guidelines that are not consistent with the new OAR or existing statutes. The placeholder also addresses more general differences with SHPO processes since the Field Guidelines were last updated. It is strongly recommended that all professional archaeologists read and understand the rule revision and familiarize themselves with all applicable statutes.

To address some recent feedback on this topic, please consider the following: the Oregon State Historic Preservation Office (SHPO) does not have the ability to change or make statute. Development or revision of an Oregon Administrative Rule (OAR) involves explaining processes identified in existing Oregon Revised Statute (ORS), or to define roles or terms included in an ORS. An OAR may not change statute.

Throughout the rule revision, representatives from the Oregon Department of Justice (DOJ) assisted SHPO towards consistency with applicable statutes (ORS 97.740-760, ORS 358.905-961, and ORS 390.235). To that objective, the revision began by seeking advice from Oregon Tribes and the Legislative Commission on Indian Services (LCIS), as required in ORS 390.235 (1) (d) as the process for developing rules. Based on five months of consultation with Oregon Tribes and LCIS, including a SHPO/Oregon Tribes/LCIS forum to address comments received and answer questions, the first draft of the rule was generated.

Next, a Rule Advisory Committee (RAC) was formed, with representatives from: Coquille Indian Tribe, Confederated Tribes of the Warm Springs Reservation of Oregon, LCIS, SHPO, University of Oregon Museum of Natural and Cultural History (UOMNCH), the Association of Oregon Archaeologists (AOA), United States Army Corps of Engineers (Corps), Oregon Department of Transportation (ODOT), Portland State University (PSU), the Association of Oregon Counties, and the League of Oregon Cities. The RAC met three times for all-day meetings, beginning with the initial Oregon Tribes/LCIS/SHPO draft. After each RAC, a new draft was generated based on discussions, suggestions, and comments. The RAC meetings were open to the public, and can still be viewed [online](#). The final RAC resulting in the fourth draft of the rule revision. After the RAC, a public meeting was held. For the entire process, notifications were sent out through various means (Oregon Heritage Listserv, Oregon Heritage Exchange Blog, and @OregonHeritage Facebook) regarding how to live stream RAC meetings, where to attend public meetings, and how and when to submit comments during the public comment periods.

After the RAC and public meeting, there was a two-month public comment period. Based on comments received, an updated draft rule was developed. However, one of the comments for the new State Physical Anthropologist position at LCIS was considered significant enough that it led to an additional one-month public comment period. After 16 months of seeking advice from Oregon Tribes and LCIS, three RAC meetings, formal tribal consultation, and three months of public comments, a final rule governing the issuance of archaeological permits was complete. In December of 2022, the rule making

process was officially closed and the rule was adopted. The rule revision includes a date for implementation - July 1, 2023.

Statutes, Administrative Rules, and SHPO:

Some feedback regarding the rule revision, suggests a reminder of applicable ORS is necessary. As stated above, SHPO does not have the ability to change or make statutes. Administrative rules are different than statute, and may not contradict any ORS that they address. They also involve an extensive process.

As discussed above, for the permit statute (ORS 390.235), the revised administrative rule (OAR 736-051-0000 to 0090) was developed through lengthy discussions with Oregon Tribes and LCIS (as required in ORS 390.235), a RAC, a public meeting, a three-month public comment period, and DOJ review - all occurring over a 16-month period.

The new rule governs the issuance of archaeological permits in Oregon. The associated statutes define when a permit is needed. Since two of the triggers are based on any excavation, destruction, alteration... of an archaeological site, and any collection of an archaeological object, the existing definition of those in statute must be followed in the permitting rule.

ORS 358.905 definition of an archaeological object:

"Archaeological object" means an object that:

(A) Is at least 75 years old;

(B) Is part of the physical record of an indigenous or other culture found in the state or waters of the state; and

(C) Is material remains of past human life or activity that are of archaeological significance including, but not limited to, monuments, symbols, tools, facilities, technological by-products and dietary by-products.

ORS 358.905 definition of an archaeological site:

(1) (c) "Archaeological site" means a geographic locality in Oregon, including but not limited to submerged and submersible lands and the bed of the sea within the state's jurisdiction, that contains archaeological objects and the contextual associations of the archaeological objects with:

A. (i) Each other; or

(ii) Biotic or geological remains or deposits.

ORS 358.920 Prohibited Conduct:

(1) (a) A person may not excavate, injure, destroy or alter an archaeological site or object or remove an archaeological object located on public or private lands in Oregon unless that activity is authorized by a permit issued under ORS 390.235 (Permits and conditions for excavation or removal of archaeological or historical material).

ORS 390.235:

(1) (d) The SHPO (Designee of the Director), with the advice of the Oregon Indian tribes and Executive Officer of the [Legislative] Commission on Indian Services, shall adopt rules governing the issuance of permits.

Updates Placeholder for the Oregon Archaeological Field Guidelines:

The following identify specific information and page numbers in the Field Guidelines that require updating. Most of the updates are a result of the revision to the rule governing the issuance of archaeological permits in Oregon. Other more general updates were already needed, and are addressed as well.

- Page 9 of 153: The definition of an archaeological object, and archaeological site, are as defined in statute (see ORS 358.905 definition of an archaeological object and archaeological site).
- Page 11 of 153: Oregon Qualified Archaeologist cites the ORS 390.235 criteria, which has not been changed. The revision to the rule (OAR 736-051-0070 [23]) created necessary definitions for terms used in the ORS 390.235 Oregon Qualified Archaeologist criteria. The Oregon Qualified Archaeologist criteria in statute are included below, with bold text and brackets added to separate terms that have been defined in the rule revision, specifically in OAR 736-051-0070.

(6) (b) "Qualified archaeologist" means a person who has the following qualifications:

*(A) [A **post-graduate degree in archaeology**], anthropology, history, classics or other germane discipline with a [**specialization in archaeology**], or a [**documented equivalency**] of such a degree;*

*(B) [**Twelve weeks**] of [**supervised**] experience in basic [**archaeological field research**], including both survey and excavation and [**four weeks**] of laboratory analysis or curating; and*

*(C) Has designed and executed an archaeological study, as evidenced by a [**Master of Arts or Master of Science thesis, or report equivalent in scope and quality, dealing with archaeological field research**].*

- Page 11-12 of 153: The List of Archaeological Consultants is no longer maintained by SHPO. Please go to the Association of Oregon Archaeologists (AOA) [contractor directory](#):
- Page 12 of 153: ORS 192.501 (11) is now ORS 192.345 (11).
- General Comment 1: Most hyperlinks in the Archaeological Field Guidelines do not work.
- Page 13 of 153 (numbers correspond to the same as listed on the page):
 - 1) Number of archaeological sites and reports are out-of-date
 - 2) Currently accessed through an Oregon Archaeological Records Remote Access (OARRA – pronounced like “aura”) account.
 - Please note, not all reports and information are accessible from OARRA.
 - Permit applicants may need to coordinate with tribes on their research design, according to the rule revision.
 - Strongly recommended to work with tribes and all other appropriate communities through their processes (permit or not) regarding additional information on archaeological sites, places, history, context, etc.
 - SHPO is not a one stop source of information on any National Register defined property types, primary or secondary sources, or information necessary to develop or understand the context of an area of investigation.

- 3) This is no longer accessible.
 - 4) Currently available through OARRA. Please also refer to 2) above.
 - 5) Currently available through OARRA
 - 6) Currently available through OARRA. Please note, OARRA General Land Office (GLO) maps only include a Township from one year. Other sources with GLO information should be included as part of pre-field research to address earlier or later surveys, including surveyor field notes.
 - 7) Currently available through OARRA
 - 8) Currently available through OARRA
 - 9) Currently available through OARRA
- Page 13-15 of 153: Access to Archaeological Records is granted to individuals that are able to demonstrate they meet the requisite requirements, which are included as a dropdown menu on the OARRA application (available through our website).
 - Page 17 of 153: There is no need to append any archaeological site or object forms to a report. The fillable .pdf report cover page available on our website includes fields for form numbers. That is all that we need. In addition, the reason SHPO has a fillable document, is so that staff can enter data into the form once it is submitted to our office, or copy and paste information into our report database. Please avoid filling out the form, printing it, and then sending the printed copy to our office.
 - Page 17 of 153: With the emphasis on the definition of archaeological objects and sites resulting from the permit rule revision, please use the definitions above (and in statute) when assessing whether to fill out a site form, or an archaeological object “isolate” form.
 - Page 19 of 153: The last sentence is no longer applicable, regarding permits on private lands. The permit rule revision no longer allows boundary probes beyond an archaeological site to be excavated without a permit (OAR 736-051-0090 [1] [c]).
 - Page 21 of 153: The permit rule revision now requires an Inadvertent Discovery Plan (IDP) specific to any Native American burial, human remains, funerary objects, sacred objects or objects of cultural patrimony. It must include the correct contact information for Oregon State Police, the LCIS State Physical Anthropologist, Oregon Tribes, and Oregon SHPO State Archaeologist, and Assistant State Archaeologist.
 - Page 28-29 of 153: Please note, under Notification, either the names, titles, or contact information have changed. The State Physical Anthropologist is also missing from the list.
 - Page 36 of 153: Please note under Treating Isolated or Limited Subsurface Artifacts, the definition of a site and archaeological object from statute (included above) will replace the definitions for the same in this and other sections. Please note, whether the term “artifact” or “isolate” is used, they are synonymous with the ORS 358.905 defined **archaeological object**.
 - Page 36 of 153: The text regarding collection of an arrowhead is no longer in OAR 736-051-0090. Text relating to unintentional discovery of an object is located in ORS 358.915. Professional archaeologists should strive for higher ethics, and apply for a permit for the collection of an archaeological object. Please refer to the rule revision OAR 736-051-0090 (1) (c) which states: *If additional investigation is necessary for an archaeologist to establish the boundary of the site, continue excavation of any exploratory probes, or conduct further archaeological excavations or collection of archaeological objects, it will require a permit that the department issues pursuant to this rule.*

- Page 39 of 153: The OAR reference in the first sentence on the page should be OAR 736-051-0080 to 0090. It should also be noted that collection of archaeological objects, surface or from excavation requires a permit.
- Page 39 of 153: Funding letters are recommended by SHPO for permit applications, but not required. The applicant to an archaeological permit, however, is responsible for completing the terms and any conditions of an issued permit.
- Page 44 of 153: Please note, for the section on conducting background research, the new rule defines “Tribal Coordination” as meaning: *a bilateral process of discussion, cooperation, and decision-making about a proposed investigation to assist with the development of an archaeological permit research design* (OAR 736-051-0070 [28]).
 - 1) Please note: SHPO records DO NOT cover all information about a place, including all archaeological sites, historic properties of religious and cultural significance to an Indian Tribe (which can include archaeological objects and sites), tribal knowledge, etc. Please also consider sources such as:
 - Publications
 - Journal Articles
 - Tribal Publications
 - Tribal Websites
 - 2) Background research is more than identifying other archaeological investigations in an area, and putting them in a table. An important part of background research should provide information on the context of an area. The context, can provide support for National Register of Historic Places (NRHP) eligibility under any of the four criteria, and whether or not (e.g.,) a district exists that includes a cultural landscape, HPRCSIT, archaeological sites, and archaeological objects.
- Pages 44-57 of 153: Be mindful that archaeological field methods should be replicable.
- Page 72-79 of 153: While the guidelines identify that precontact archaeological sites may be eligible for inclusion in the NRHP under any of the criteria, but are most often under Criterion D, the guiding process is important to understand. For the section in the guidelines that address eligibility for archaeological sites, there are a number of important things to consider. The following addresses several topics related to this section of the guidelines for added context.

The National Register (NR) Bulletins (15, 16A, 36, 38, etc.) provide excellent guidance for developing context statements and understanding how archaeological sites can be eligible under the four National Register of Historic Places (NRHP) criteria. It is important to note, however, that National Register Bulletins are not the same as Oregon Revised Statute (ORS), or the National Historic Preservation Act (NHPA).

National Register Bulletins provide guidance for nominating a property under any circumstance. As such, some bulletins recommend only using the best criterion for which the strongest case can be made, or the one that is typically used the most for a property type (e.g., Criterion D for archaeological sites).

While that is true for nominations that are not following other processes, identifying a “significant” archaeological site under ORS 358.905-961 or evaluating any historic

property under 36 Code of Federal Regulations (CFR) 800 requires applying all four criteria. The reason for the difference aside from being written in 36CFR800 and necessary to comply with statute, is that the legal processes involve assessing effects to such properties and if needed, mitigating based on the qualities and characteristics that make them eligible to the NRHP. Assessments under each of the criteria provide the necessary range of qualifying characteristics to assist with ways to minimize, avoid, or mitigate adverse effects.

Buildings, Sites, Districts, Structures, or Objects: The only property types eligible for inclusion in the NRHP are buildings, sites, districts, structures or objects. Archaeological sites, Traditional Cultural Places (TCP), Historic Properties of Religious and Cultural Significance to an Indian Tribe (HPRCSIT), cultural landscapes, storied landscapes, etc. may all eligible to the NRHP, but they still need to fall into one of the five eligible property types.

For example, archaeological sites most often fit in the “Site” or “District” types. While TCP, HPRCSIT, cultural landscapes, and storied landscapes may more often fall into the “District” type, for some, the “Site” type may be more appropriate. There are exceptions to these and how they may fit into the NRHP property types. Archaeologists should understand the definitions of these property types in NR Bulletin 15.

GUIDELINES FOR CONDUCTING FIELD ARCHAEOLOGY IN OREGON

**Oregon State Historic Preservation Office
Salem, Oregon**

November 2013
(Minor Revision January 2016)

FORWARD

The Secretary of the Interior has developed broad national performance standards and guidelines to assist federal agencies in carrying out their historic preservation activities. These federal standards and guidelines are entitled *Archeology and Historic Preservation; Secretary of the Interior's Standards and Guidelines* (48 FR 44716-44742). Professionals working in the United States have long recognized the need to standardize archaeological field investigations; however, standardization has been slow to appear in the Pacific Northwest. Oregon SHPO's Guidelines¹ were established to meet this need and to fill the gap between the broad-based federal guidelines and the various previously published field manuals. They are intended to provide standards and offer general guidance without hindering the development and use of new and innovative approaches.

The intent is to clarify expectations for archaeologists, their clients and the public. The Guidelines describe widely accepted archaeological practices used in the Pacific Northwest Region. They also encourage the selection of methods and techniques generally found to be the most efficient and cost-effective. It is hoped that these guidelines will enable project sponsors to better understand and assess proposals for archaeological survey. Users of the Guidelines should feel free to contact SHPO staff with questions about particular problems or projects. It is anticipated that the Guidelines will be updated at regular intervals to incorporate unanticipated considerations and new approaches. The Guidelines were written primarily to cover activities on non-federal public and private lands in Oregon. Federal land managers deal with a different array of cultural resource laws and regulations, and after gaining a familiarity over their land-base, after many years of compliance survey and testing projects, have often instituted their own guidelines for working on their lands. Oregon SHPO's Guidelines are not meant to replace existing federal guidelines or mandate a change in their accepted strategy. Rather the Guidelines offer a summary of general archaeological practices that may be applicable throughout the state. If your project affects federal land in Oregon, be sure to contact the federal land managing agency to see if they operate under their own set of cultural resource guidelines.

So as not to "reinvent the wheel" these Guidelines represent a summary of information that has been drawn from other published SHPO guidelines (e.g., Arkansas, Florida, Mississippi, Vermont, Virginia) and practical experience working in the Pacific Northwest. These Guidelines should be considered a work in progress. Comments by archaeologists working in both the public and private sector are encouraged.

¹ References to Oregon SHPO's Field Guidelines are hereafter denoted by the term "Guidelines".

TABLE OF CONTENTS

FORWARD.....	2
TABLE OF CONTENTS.....	3
INTRODUCTION	6
I. BASIC SITE/PROJECT INFORMATION	9
DEFINITION OF AN ARCHAEOLOGICAL SITE.....	9
“PRECONTACT” AND “PREHISTORIC”	10
THREE PHASES OF ARCHAEOLOGICAL INVESTIGATIONS.....	10
CRITERIA FOR QUALIFIED PROFESSIONAL ARCHAEOLOGISTS	11
Confidentiality of Sensitive Archaeological Site Information.....	12
SHPO Archaeological Records.....	12
Access to Archaeological Records.....	13
Professional Qualifications for Field Archaeologists	15
Determining Which Inventory Form to Use	16
II. ARCHAEOLOGICAL PRACTICES	18
INTRODUCTION	18
BACKGROUND RESEARCH	18
AREA OF POTENTIAL EFFECTS (APE).....	18
FIELD INSPECTION/SURVEY OR SITE VISIT.....	19
MAP DOCUMENTATION.....	20
DEFINING SITE BOUNDARIES	20
TREATMENT OF INADVERTENT DISCOVERIES & SITE PRESERVATION	21
Inadvertent Discovery in the Course of Project Construction	21
Treating an Unanticipated Site Once Discovered.....	22
Long Term Site Preservation Through Easements or Fee Simple Purchase	22
CURATION OF ARTIFACTS AND DOCUMENTATION	23
If a Site is Located on Public Land.....	23
If a Site is Located on Private Land.....	24
Treatment of Human Remains	25
Treatment of Native American Human Remains Discovered Inadvertently or Through Criminal Investigations on Private and Public, State-Owned Lands in Oregon.....	28
III. STANDARD FIELD METHODOLOGY	30
FIELD METHODS	30
Surface Survey	30
Remote Sensing	32
Monitoring	32
Sub-Surface Testing.....	32
Historic Archaeological Site Recordation	34
Recording Measurements.....	35
Establishing a Permanent Site Datum.....	35
ISOLATED FINDS	35
Treating Isolated or Limited, Surface Artifacts	35
Treating Isolated or Limited Sub-surface Artifacts	36
ARTIFACT COLLECTION POLICY	36
Pedestrian Survey.....	36
Subsurface Site Discovery Probes	37

Excavation Units (50x50 cm and larger used in Testing and Data Recovery Projects)	37
DEFINING PREVIOUS “SIGNIFICANT” GROUND DISTURBANCE	38
PERMITS FOR ARCHAEOLOGICAL INVESTIGATIONS ON NONFEDERAL PUBLIC AND PRIVATE LANDS.....	39
CONSIDERING STANDING STRUCTURES IN THE PROJECT AREA.....	39
INVOLVING THE PUBLIC	40
UNDERWATER ARCHAEOLOGY	41
IV. ARCHAEOLOGICAL FIELD INVESTIGATIONS	42
LEVELS OF INVESTIGATION.....	42
RESEARCH DESIGN: ALL PHASES	42
PHASE I INVESTIGATION: IDENTIFICATION STUDY	43
PHASE I FIELD INVESTIGATIONS: FIELD STUDY	45
DATA ANALYSES & REPORTING	50
PHASE II INVESTIGATION: EVALUATION STUDY	50
PHASE III INVESTIGATION: DATA RECOVERY STUDY.....	54
MITIGATION.....	58
ARTIFACT PROCESSING, DATA ANALYSES AND CURATION	61
SUMMARY	64
BIBLIOGRAPHY	66
APPENDICES	67
APPENDIX A: ESTABLISHING SITE SIGNIFICANCE.....	68
Determining Significance under Criteria D.....	72
Ability to Answer Questions Important to Understanding Oregon’s Past.....	73
Establishing Historic Period Site Significance	75
Defining a “Site” in the Context of Historic Period Archaeology.....	76
Research Topics to Help Evaluate Significance of Historic Period Sites.....	76
Identifying Important Research Questions and Necessary Data Sets.....	77
Quality of Site Evidence	77
Summary of Information SHPO Needs to Determine if Site Assessment Process Should Continue.....	77
POTENTIAL SIGNIFICANCE OF ISOLATED FINDS.....	78
DETERMINING THE AMOUNT OF IMPACT ON A SIGNIFICANT SITE.....	78
APPENDIX B: PRERSERVATION DEED COVENANT (SAMPLE)	80
APPENDIX C: CURATIONS STANDARDS AND GUIDELINES FOR ARCHEOLOGICAL INVESTIGATIONS IN OREGON.....	83
APPENDIX D: REQUEST FOR REPATRIATION OF ARCHAEOLOGICAL MATERIAL FROM OREGON NON-FEDERAL PUBLIC & PRIVATE LANDS FORM.....	99
APPENDIX E: ARCHAEOLOGICAL MONITORING GUIDELINES.....	101
APPENDIX F: VOLUMES – SQUARE, CYLINDER, CONE & TRUNCATED CYLINDER	128
APPENDIX G: GUIDELINES FOR UNDERWATER ARCHAEOLOGY	130
Phase I: Submerged Cultural Resources Survey.....	133
Phase II: Submerged Cultural Resource Testing and Evaluation	137
APPENDIX H: PROTOCOL FOR COLLECTION OF COPROLITES FOR DNA ANALYSIS	141

APPENDIX I: EXAMPLES OF MEMORANDUM OF AGREEMENTS & PROGRAMMATIC AGREEMENTS..... 145

 EXHIBIT A: THREE PARTY MEMORANDUM OF AGREEMENT..... 146

 EXHIBIT B: TWO PARTY MEMORANDUM OF AGREEMENT..... 149

 EXHIBIT C: PROGRAMMATIC AGREEMENT 152

INTRODUCTION

People have lived in Oregon for over 14,000 years. The vast majority of that history is unwritten with information concerning past events and lifeways accessible only through the archaeological record. Archaeological investigations in Oregon predominantly occur in response to federal and state laws that protect archaeological resources. The Oregon State Historic Preservation Office (SHPO) developed these Guidelines to provide a framework for those activities, as well as guidance for non-regulatory archaeological studies. These Guidelines provide an important perspective for refining and improving the current practice of archaeology in Oregon.

The Guidelines reflect various goals for Oregon archaeology:

- Ensure that archaeological research meets the highest professional standards.
- Identify important archaeological sites that contribute to our understanding of Oregon's precontact and post-contact history.
- Protect important archaeological sites and, when appropriate, gather information.
- Provide meaningful public benefits.
- Develop sound and reasoned public policy on regulatory archaeology.
- Keep archaeological studies as cost effective as possible.
- Standardize field methodology while allowing creativity and flexibility in the conduct of archaeological studies.

The Guidelines emphasize public education and communication with clients, landowners, local governments, tribes, community members, and interested constituencies. The Guidelines also stress the need for clear and improved communication about archaeological expectations, methods, findings, value, and relevance. These Guidelines are meant to allow for flexibility to ensure that the scope and cost of recommended archaeological actions are commensurate with a project's scale, level of anticipated impacts, project area characteristics, and the significance of sites that may be affected by the project. Archaeologists are encouraged to suggest alternative approaches to the Oregon SHPO whenever appropriate.

These Guidelines emphasize the importance of prioritizing archaeological investigations in an effort to focus consideration on the discovery of significant archaeological sites. The Guidelines also emphasize the importance of evaluating the significance of a site as early as possible in the archaeological assessment process.

The Guidelines are designed to provide technical guidance for archaeological professionals, federal and state agencies, private developers, researchers, and anyone else involved in Oregon archaeology. We recommend that the Guidelines be followed by all archaeologists working within the regulatory review process in Oregon, to ensure that the State's goals for Oregon archaeology are met and to help ensure appropriate compliance with federal and state laws (with exceptions noted below).

These guidelines are designed to assist archaeological field investigations and the recording of archaeological sites. Field investigations that involve above-ground resources should be completed by qualified personnel and coordinated with the SHPO's above-ground compliance

specialists. Researchers working with built-environment resources should contact Jason Allen (503-986-0579; Jason.Allen@oregon.gov) or Ian Johnson (503-986-0678; Ian.Johnson@state.or.us) at Oregon SHPO to comply with the guidelines for built-environment field recordation. If you are confused as to which type of resources a site belongs and the appropriate form to be completed (e.g., archaeological site form, built-environment form) refer to Table 1 in the State of Oregon Archaeological Reporting Guidelines for clarification (http://www.oregon.gov/OPRD/HCD/ARCH/docs/State_of_Oregon_Archaeological_Survey_and_Reporting_Standards.pdf).

The Oregon SHPO is involved in two major categories of project reviews:

1. Reviews in accordance with federal laws, primarily under Section 106 of the National Historic Preservation Act, referred to as “Section 106,” and sometimes under Section 110 of the Act. Under Section 106, federally funded, licensed, permitted, and assisted projects are subject to review. These regulations are codified in 36CFR800.
2. Reviews under state laws, primarily ORS 97.740-760 (*Indian Graves and Protected Objects*) and ORS 358.905-961 (*Archaeological Objects and Sites*).

In complying with Section 106 and Section 110, some federal agencies may have different requirements and procedures based on the nature of their programs and statutory authorities. Sometimes, alternative practices and requirements to these Guidelines are established in Programmatic Agreements in accordance with Section 106. Various portions of these Guidelines remain applicable to the conduct of archaeological assessments under any Programmatic Agreement. In particular, Appendix A relating to “Evaluating Site Significance” is intended to guide federal agencies doing archaeological project reviews in Oregon. Archaeological investigations on federal and state lands have additional requirements that supplement these guidelines. For example, permit provisions are established in federal (specifically the federal *Archaeological Resources Protection Act*) and state statute (Oregon’s ORS 390.235 - *Permit and Conditions for Excavation and Removal of Archaeological or Historical Material on Public and Private Land* – and it’s associated Administrative Rules [OAR 736-051-0000 to 0090]).

The Oregon SHPO, as well as federal and state land managers, will advise consulting archaeologists when additional or different provisions apply on public lands or to Programmatic Agreements. These Guidelines incorporate the Secretary of the Interior's Standards and Guidelines for identification, evaluation, and archaeological documentation. Professionals must ensure that all archaeological studies meet the relevant Secretary of the Interior's Standards and Guidelines (available at http://www.cr.nps.gov/local-law/arch_stnds_0.htm).

These Guidelines are organized into four major sections, describing the archaeological process from a general introduction of basic terms and policies to a detailed outline of each archaeological investigative phase. These sections include: I) Basic Site/Project Information; II) Archaeological Practices; III) Standard Field Methodology; and IV) Archaeological Field Investigations.

Section I – Basic Site/Project Information (pg.9) – provides a definition of an archaeological site in Oregon, outlines the criteria needed to be considered a professional archaeologist, and summarizes information regarding archaeological resources or research tools available at the Oregon SHPO, including access policy and confidentiality of site information. This section is designed to provide basic information helpful to the general public as well as professional archaeologists working within Oregon.

Section II – Archaeological Practices (pg.18) – provides a description of the basic components of a site investigation (e.g., background research, determining a project’s Area of Potential Effect (APE), field inspection, site boundaries, and significance). This section is designed to familiarize clients, landowners, local governments, community members, and local constituencies with the archaeological review process so that the steps and goals are easily understood and supportable.

Section III – Standard Field Methodology (pg.30) – provides an overview of the different components involved in an archaeological investigation. This section is not only designed to inform the public of the archaeological process but is also designed to remind professional archaeologists of the range of alternatives at their disposal so that site evaluations and mitigation decisions are well thought out and commensurate with the proposed action.

Section IV – Archaeological Field Investigation (pg. 42) – describes the three basic phases of an archaeological investigation: 1) Site Discovery, 2) Site Evaluation, and 3) Mitigation. This section provides detailed guidelines for fieldworkers to assist them in completing their investigations.

I. BASIC SITE/PROJECT INFORMATION

DEFINITION OF AN ARCHAEOLOGICAL SITE

In general terms, an Archaeological Site is defined as:

- A) Ten or more artifacts (including debitage) likely to have been generated by patterned cultural activity within a surface area reasonable to that activity; or
- B) The presence of any archaeological feature, with or without associated artifacts. Examples of such features include: a culturally modified tree, cache pit, hearth, housepit, rockshelter, cairn, historic mining ditch, petroglyph, or historic dendroglyph.

In general terms, an Isolated Find is defined as:

Any precontact or historic artifact occurrence that does not qualify for a site designation (i.e., ≤ 9 artifacts). Subsurface investigation may be necessary to support an isolate's status.

In Oregon, an archaeological site is greater than 75 years of age (50 years of age on federal lands or related projects). Examples of archaeological sites would include: domestic/habitation sites, industrial sites, lithic scatters, middens, mounds, quarries, mines, stacked rock features, culturally modified trees, shipwrecks, petroglyphs, etc.

The presence of directly observed cultural material and/or feature(s) is the basis for recording a site. Archaeological sites are rarely defined solely on the basis of informant testimony. Direct observation of features and/or artifacts should always be sought to substantiate informant information. Generally, unsubstantiated informant testimony (i.e., tickler) should be noted within a survey/project report, but not on an archaeological site form. While exceptions to this policy may exist, they should be considered rare. For example, in cases where multiple informants offer independent, similar and/or supportive information on different dates with regards to the location and composition of a particular site (e.g., historic burial), a site form should be used to record this resource.

Site boundaries should be defined by direct observation of features and/or artifacts. Topography may be used to suggest potential boundaries that should be verified by testing, but these should be illustrated differently on the site form than boundaries determined through direct observation. In addition, historic background information should be taken into consideration when defining the boundaries of a historic site. There is no "standard" size for determining a site's boundaries in relationship with observed artifacts. Artifacts do not have to lie within 30 feet or 30 meters of each other to be considered part of a single site. Such an assessment should be made by the archaeologist based on landform and possible past land use activities.

“PRECONTACT” AND “PREHISTORIC”

The terms “precontact” and “prehistoric” describe over 14,000 years of Native American history prior to contact with Europeans. Many archaeologists, Native Americans and historians who work in Oregon support the use of the term precontact. Thus, the Oregon SHPO uses precontact throughout these Guidelines to describe the thousands of years of rich Native American culture before European contact. The terms prehistoric and precontact are interchangeable and using one or the other is a personal preference.

THREE PHASES OF ARCHAEOLOGICAL INVESTIGATIONS

There are three phases of archaeological investigation that need to be considered for all projects. These phases outline the steps of investigation that need to be followed in order to identify, determine significance of and mitigate for adverse effect to any significant sites that may be affected by a proposed project. These three phases are:

Phase I - Identification Study: The goal of Phase I investigations is to locate all archaeological sites that may exist within a proposed project’s Area of Potential Effect (APE) that are potentially eligible to the National Register of Historic Places (NRHP). In order to accomplish this goal, a thorough background research of the history of land use activities within the project area is completed. This research should be followed by a surface survey of the project area and the excavation of subsurface probes in areas of high probability and typically low visibility. Subsurface probes are considered an important component of this phase in order to determine the location, nature and boundaries of any potentially significant archaeological sites that may not be visible on the ground surface due to previous ground disturbing activities (e.g., plowing, filling, industrial or residential development), natural burial processes (e.g., alluvial or aeolian deposits) or heavy vegetation. All discovered sites should be avoided and/or protected until they can be evaluated for their potential eligibility/significance. If no sites are identified during this phase the project is presumed to have no effect on archaeological resources. Should the project’s APE change this Phase I investigation may need to be revisited.

Phase II - Evaluation Study: The goal of Phase II investigations is to establish whether or not a site identified during Phase I meets the criteria for eligibility to the National Register of Historic Places. To accomplish this task, subsurface excavations are conducted to establish a site’s horizontal and vertical boundaries, general site integrity and composition. In some cases, testing is not necessary due to a preponderance of evidence regarding the site’s history, composition and integrity already being known (e.g., exposed cut-banks, shallow soil development, historic documentation, previous research). In such cases, an assessment of our knowledge of the site is compiled to establish the likelihood of the site containing information important to our local, state, and/or national history. Sites that are found to be ineligible to the NRHP are promised no

protection and need no further evaluation under the National Historic Preservation Act unless, through the passage of time, changing perceptions of significance, or incomplete prior evaluations, may require an agency to reevaluate the property (36 CFR 800.4(c)(1)). However, some federal agencies continue to manage such sites (e.g., Federal Land Protection and Management Act-FLPMA) for their importance in the agency's missions, such as public interpretation, cultural use or a lesser level of scientific importance than that supported by the NRHP. Sites identified as eligible should be avoided and/or protected. If impacts are unavoidable efforts should be aimed at minimizing any unnecessary impacts. Those sites or portions of sites that are found to be significant to the NRHP and that cannot be avoided or protected will need to receive mitigation under Phase III.

Phase III - Data Recovery: The goal of Phase III investigations is to recover the maximum significant cultural, environmental, and interpretive information and values from a site before it is destroyed in whole or in part. This investigative phase focuses around the use of data recovery through controlled excavation, and should include a high level of public education and outreach to ensure that the proposed destruction of the site provides maximum benefits to a wide audience.

Each of these phases will be discussed in greater detail in Section IV of these Guidelines.

CRITERIA FOR QUALIFIED PROFESSIONAL ARCHAEOLOGISTS

Archaeological investigations in Oregon should be conducted by qualified archaeological professionals who meet the state's definition of a "qualified archaeologist", the Secretary of the Interior's Professional Qualification Standards, or for federal agencies, Office of Personnel Management (OPM) standards. Archaeological investigations conducted pursuant to federal and state laws must be conducted by qualified professionals. Under Oregon State Statutes (ORS 390.235(6) (b)) a "Qualified archaeologist" means a person who has the following qualifications:

- (A) A post-graduate degree in archaeology, anthropology, history, classics or other germane discipline with a specialization in archaeology, or a documented equivalency of such a degree;
- (B) Twelve weeks of supervised experience in basic archaeological field research, including both survey and excavation and four weeks of laboratory analysis or curation; and
- (C) Has designed and executed an archaeological study, as evidenced by a Master of Arts or Master of Science thesis, or report equivalent in scope and quality, dealing with archaeological field research.

For additional information on the Secretary of Interior's Professional Qualification Standards, see http://www.nps.gov/history/local-law/arch_stnds_9.htm. For information regarding Oregon State's requirements to be considered a "Qualified Archaeologist" see <http://www.oregon.gov/OPRD/HCD/ARCH/Pages/index.aspx>. As a courtesy to agencies, developers, communities, and other users, the Oregon SHPO maintains a **List of Archaeological Consultants** (<http://www.oregon.gov/OPRD/HCD/ARCH/docs/archaeologists.pdf>). Each

of these consultants and/or agencies possess at least one qualified professional that meets Oregon state law and the Secretary of the Interior's Professional Qualification Standards and have demonstrated ability to meet the Secretary of the Interior's Standards and Guidelines for identification, evaluation, and archaeological documentation (see http://www.cr.nps.gov/local-law/arch_stnds_0.htm). There may be other qualified consultants that do not appear on this list. The Oregon SHPO has established procedures for listing organizations or individuals on the consultant's list. Qualified professionals do not need to be on the consultant's list to conduct investigations in Oregon but the Oregon SHPO encourages their listing. SHPO will only accept reports (Phases I, II and III) resulting from Section 106, antiquities or state law projects from individuals or companies who meet these federal standards. If your project involves aboveground historic resources, Oregon SHPO requires agencies to retain qualified personnel who meet the Secretary of Interior's Professional Qualification Standards for History or Architectural History.

Inclusion on SHPO's archaeological consultants' list does not imply that the Oregon SHPO certifies personal or corporate qualifications nor does Oregon SHPO recommend or endorse these individuals or organizations. Work by individuals or organizations appearing on this list do not receive any special consideration. Oregon SHPO considers a thorough knowledge of Oregon and regional precontact and historic period archaeological, historic and ethnographic literature a key requirement for conducting high quality archaeological investigations in Oregon. Thus, for example, understanding the Paleo-Indian period in Oregon is impossible without knowing the Paleo-Indian literature for the Plateau, Northern Great Basin and Northwest Coast Regions.

Confidentiality of Sensitive Archaeological Site Information

In Oregon SHPO's experience, more sites are destroyed by lack of knowledge than by looting². Public education about archaeological sites is an important goal for Oregon archaeology and the SHPO.

By and large, disseminating general, non site-specific results of field investigations to local governments and other community organizations, landowners, libraries, and interested citizens is the preferred practice. However, to protect fragile, vulnerable, or threatened sites, the National Historic Preservation Act, as amended (Section 304 [16 U.S.C. 470s-3]), and Oregon State law (ORS 192.501(11)) establishes that the location of archaeological sites, both on land and underwater, shall be confidential. Under law, the Oregon SHPO may provide locational information to appropriate individuals and organizations for research and planning purposes. Oregon State law exempts archaeological site locations from the Freedom of Information Act. Specific project or site concerns with publishing or distributing site locations in reports or electronic media should be discussed with the SHPO as they arise.

SHPO Archaeological Records

² While more sites overall may be destroyed by lack of knowledge, our office acknowledges that many important and information-rich sites have been and continue to be destroyed by looting.

Oregon SHPO maintains the largest database of archaeological records in Oregon. This data is available to all professional archaeologists to assist them in conducting future project reviews. Our records include:

- 1) Library of over 25,000 archaeological reports and 30,000 archaeological site forms;
- 2) A Bibliographic database (ACCESS) of all archaeological reports including basic bibliographic information can be accessed through the state's site form log in which is found at <http://www.oregon.gov/OPRD/HCD/ARCH/Pages/index.aspx> under [Online Oregon Archaeological Site Form and Bibliographic Database](#).
- 3) Site specific data on all sites addressed in pre-2008 reports, along with an associated radiocarbon database, and obsidian source database is currently accessible on our webpage at <http://www.oregon.gov/OPRD/HCD/ARCH/Pages/index.aspx>.
- 4) GIS database (ARCVIEW 10.1) of all previously surveyed areas and site locations. This information is directly accessible to researchers through a computer terminal at our Salem office by appointment and should be available on-line through a secured website by January 1, 2014;
- 5) Computer accessible copies of original SHPO USGS topographic maps showing state survey data mapped before 2002, georeferenced with current 7.5' USGS maps;
- 6) GLO maps for the State of Oregon (some are georeferenced while others are accessible in .pdf form);
- 7) Orthophotos for the State of Oregon (georeferenced on GIS database);
- 8) Computerized copies (i.e., .pdf files) of the majority of site forms and survey reports linked to the SHPO GIS and bibliographic databases; and
- 9) A site form database that will provide a searchable link between all recorded archaeological site forms. This site form database is designed as a web-based form but it will take several years to access data from all previously recorded sites. All new site forms should automatically be entered into this database (<http://heritagedata.prd.state.or.us/#request.self#>).

Access to Archaeological Records

It is in the public interest to protect Oregon's cultural resources. Oregon SHPO recognizes this need and therefore restricts access to some cultural resource information. Although SHPO reserves the right to restrict access to various types of cultural resource data, Oregon state law exempts archaeological site locations from the Freedom of Information Act. SHPO recognizes the need of scholars, researchers, archaeology and history consultants, and other public citizens to have access to these files in order to perform their jobs relating to the identification and protection of cultural resources.

The Purpose of this SHPO Access Policy is Four-Fold:

1. Assure that only qualified researchers have access to confidential and sensitive information.
2. Maintain a defensible record of who has viewed specific records
3. Ensure that the user is aware of the appropriate uses and limitations of the records
4. Provide an efficient format that is accessible to researchers and as a result, SHPO staff can fulfill their daily responsibilities.

The following guidelines concerning access pertain to all cultural resource records at SHPO, including but not limited to forms, documents, maps, images and digital information. Copies (.pdf) of most survey reports and site forms can be accessed through a researcher's computer at our Salem office, and soon through a secure on-line website. These documents are linked to our GIS and bibliographic (ACCESS) databases. At the SHPO office paper copies of all documents can be made; however, electronic copies of the data are currently not available. Completing a Request Form, when visiting the SHPO office, provides access to any records not currently available in scanned format. SHPO staff will provide the individual with the requested information based on the guidelines outlined below. Users may not have access to files other than those provided by SHPO staff.

Access by Professional Archaeologists

Individuals working on archaeological projects who meet at least one of the following criteria may be provided with unrestricted archaeological records:

1. All "Qualified Archaeologists" as defined in ORS 390.235(6)(b).
2. Members of the Register of Professional Archaeologists (RPA).
3. Archaeologists (with written justification) who are working for an agency or consulting firm where their immediate supervisor meets the qualifications listed in option 1 or 2 above.
4. Graduate students with written justification for access from qualified faculty – (access may be for a limited time -- i.e., project/thesis oriented).
5. All professional archaeologists who work as the cultural resource specialist with a federal or state agency, possessing a minimum of a Bachelor's degree in anthropology with a specialization in archaeology and a minimum of four years of work experience that demonstrates a thorough knowledge of the fundamental principles, theories and field methods of professional archaeology.

Access by Non-Archaeologists

Other individuals may have limited access to archaeological records. The type and extent of data available to these individuals is determined on a case-by-case basis (contact Jamie French [503-979-7580; jamie.french@oregon.gov with any questions regarding access). General information concerning the presence or absence of an archaeological site within the boundaries of a proposed project will be provided to agencies requesting such information for management purposes. Site-specific data on known sites; however, will only be provided to professional archaeologists and tribal cultural resource staff.

Procedures for Access

1. Above-ground historic records: Scanned copies of all National Register property files and Oregon's Statewide Inventory of Historic Properties are available on the SHPO website (<http://www.oregon.gov/OPRD/HCD/SHPO/index.shtml>). Access to the National Register case files and the Statewide Inventory of Historic Property forms themselves, are by appointment only. These appointments should be made at least 48-hours in

advance via phone with MaryBeth Grover (503-689-6619). The scope of the research for any National Register and Statewide Inventory files needs to be provided at the time the appointment is made, preferably by Township, Range and Section.

Archaeological Records: The [Oregon Archaeological Records Remote Access \(OARRA\)](#) offers access to individual archaeological site records and reports. Due to the restricted nature of the archaeological records, users must meet [specific criteria](#) prior to being granted an OARRA account. New researchers who wish to create an on-line OARRA account are required to provide at a minimum current resumes or Curriculum Vitae (CV) to one of the SHPO archaeologists.

- John Pouley, 503-480-9164 or john.pouley@oregon.gov
- Jamie French, 503-979-7580 or jamie.french@oregon.gov

Please Note: A list of references and contact phone numbers should accompany each request for access. If SHPO is not familiar with an archaeologist and their company or institution, a reference may be contacted or additional information requested prior to granting access to OARRA. Access for non-Oregon “qualified” archaeologists meeting any of the remaining [requirements](#) above (2-5) is on a limited duration basis. An annual audit will be conducted by SHPO to remove the accounts of those for which the conditions of access no longer apply. Additional records aside from those available through SHPO should be part of the research process (e.g., Tribal data, publications, ethnographies, library sources and collections, interviews, museum collections, historical societies, historic catalogues, agency reports and contractor reports not available at SHPO [often identifiable in References Cited sections of reports and publications], historic newspapers, maps, local historians, historic letters/journals, etc.). **Sharing an OARRA account or disseminating confidential information will result in the immediate termination of access to SHPO records.**

Once an on-line account is created it can be accessed at: <https://maps.prd.state.or.us/shpo/archaeoview.html>. An On-line Oregon Archaeological Site Form and Bibliographic Database are additionally available at: <http://www.oregon.gov/oprd/HCD/ARCH/Pages/index.aspx>.

Please note: access to some records (e.g., cemetery database, a layer of Paleoshorelines for the past 19,000 years, a submerged landform model of offshore federal waters, shipwreck database, primary references and some historic maps) are only available at SHPO. Future versions of the on-line system may contain some of these records.

Professional Qualifications for Field Archaeologists

SHPO requires individuals or groups conducting federally-funded research, or research as a result of federal or state permits and licenses in the State of Oregon, to meet the minimum professional qualifications outlined in the Secretary of the Interior’s *Standards and Guidelines*,

Archaeology and Historic Preservation's "Professional Qualifications Standards" (*Federal Register* vol. 48, no. 190, 9-29-83, Part IV, pg. 44738-44739). Throughout the duration of the investigation, either the Principal Investigator or Field Director must be present in the field directing and monitoring the activities of the Field Crew. To meet the minimum professional qualifications in archaeology:

1. The **Principal Investigator** (PI) must: 1) have a graduate degree in anthropology, archaeology, or closely related field, plus: 2) at least one year of full-time professional experience or equivalent specialized training in research, administration or management; 3) at least four months of supervised field and analytic experience in general North American archaeology; and 4) demonstrated ability to carry research to completion.

In addition to these minimum qualifications, a Principal Investigator in precontact archaeology shall have at least one year of full-time professional experience at a supervisory level in the study of resources of the precontact period. A Principal Investigator in historic archaeology shall have at least one year of full-time professional experience at a supervisory level in the study of resources of the historic period.

2. The **Field Director/s** should also have a graduate degree in anthropology, archaeology, or closely related field, and have considerable experience and demonstrated ability to successfully function in a supervisory capacity. This person should possess formal training and considerable experience in theory, methodology, analysis, interpretation, and report preparation, and have demonstrated the ability to recognize and evaluate both historic and precontact cultural features.
3. **Field Crew Member/s** should have an undergraduate degree in anthropology, archaeology, or closely related field, or possess considerable experience and have demonstrated the ability to recognize and evaluate both historic and precontact cultural features and artifacts. There are many avocational archaeologists in Oregon that routinely work closely with professional archaeologists on federal, state and privately funded archaeological projects. Oregon SHPO encourages professional archaeologists to work with the various avocational groups throughout the state (e.g., OAS) to help provide training and educational opportunities, both through lecture and field experiences.
4. **Any Archaeologist Conducting Research** (Phase I, II, and III) should have access to: 1) adequate field and laboratory equipment to conduct the survey, excavation, or other research; and 2) adequate facilities to properly treat, analyze, and temporarily curate cultural material obtained as a result of the investigation.

Determining Which Inventory Form to Use

Resource survey project personnel typically record site data using either an Oregon Archaeology Site Inventory Form (egov.oregon.gov/OPRD/HCD/ARCH/arch_forms.shtml) or a Historic Property Inventory Form (www.oregon.gov/OPRD/HCD/SHPO/preservation_106.shtml).

Samples of both forms, can be found on the Oregon SHPO web page. Archaeological site forms and isolates need to be entered into the [on-line Archaeological Sites Database](#) and appended to any reports submitted to SHPO, as appropriate.

Archaeological sites, comprised of artifacts left from past human activities, are often found beneath the ground surface (e.g., such as lithic scatters, shell middens, housepit caches and post holes, and building foundations) or above the ground (e.g., refuse scatters, collapsed log cabins, dendroglyphs). Archaeological site forms are to be completed in order to document these types of sites. [The State of Oregon Guidelines for Reporting on Archaeological Investigations](#) provide additional assistance regarding Site Records (Site Forms).

Similarly, survey projects that focus on documenting buildings, structures, districts and property types comprising the existing built environment, should use the Historic Property Inventory forms (http://www.oregon.gov/OPRD/HCD/SHPO/preservation_106_historicresources.shtml). Surveyors often come across situations where it is unclear about which inventory form to use. Some property types could justifiably be considered an historic archaeological resource as well as an historic resource. Examples of such site types include ruins of mining camps, historic wagon trails, railroad lines, or abandoned irrigation structures. In these cases, refer to the [State of Oregon Guidelines for Reporting on Archaeological Investigations](#) (see Appendix C) or contact Oregon SHPO staff for specific instructions.

State of Oregon Archaeological Site Record (Site Form)

Since March 1, 2000, all archaeological sites identified in Oregon need to be recorded and submitted to SHPO for review and approval on an Oregon SHPO **State of Oregon Archaeological Site Record (Site Form)**. Since 2009, submitting Site Form has been integrated into a on-line system (<http://heritagedata.prd.state.or.us/#request.self#>). “Likely” or “potential” site areas (i.e., ticklers) should be noted in the report text and report maps, but need not be submitted on site forms. Isolate forms should be submitted as warranted (eg., less than 10 artifacts and no features). Oregon SHPO currently accepts any isolate find form as long as it contains all required pertinent data (e.g., description and number of items found, complete legal description [Township, Range, Section], UTM location, and photos as appropriate).

II. ARCHAEOLOGICAL PRACTICES

INTRODUCTION

The purpose of archaeological investigations is to locate and protect archaeological sites *significant* to local, state, regional, and national history. It is important that all research efforts are adequately documented so that future preservation and interpretation projects can benefit from previous work. SHPO Guidelines (both Field and Report Guidelines) provide a framework for documenting the results of all archaeological investigations.

BACKGROUND RESEARCH

Background research is increasingly important to establish the potential significance of a site (an expected site or visible site) as early as possible in the archaeological assessment process. Background research establishes what types of potentially significant sites may exist in the project area and the likelihood (or not) of such sites existing in the project's locale; it helps define the character of such sites; and provides the justification for their potential significance. A thorough knowledge of local, state and regional archaeological, historical and ethnographic literature is fundamental to efficient and appropriate background research on individual projects. The extent of background research needed must be evaluated on the basis of the project area's potential archaeological sensitivity, project location, scope of work, degree of impacts, and other factors. As the name implies, background research should be completed early in the investigation process and before conducting fieldwork.

Background research should include a search of the Oregon Archaeological Records, relevant past archaeological study reports, Oregon Historic Sites and Structures Survey, National Register files, relevant historic contexts, historic maps and photographs (including General Land Office Survey maps and notes and Sanborn insurance maps) and any other pertinent publications, documents, records, and files. Much of this information is available at the Oregon SHPO office in Salem or available through an [OARRA](#) account. Oral history can also be an important source of information. Interviews with knowledgeable local individuals and landowners (both Native and non-Native) may be appropriate. Guidelines for conducting oral history interviews are available on the Oregon SHPO web page (http://egov.oregon.gov/OPRD/HCD/ARCH/arch_oral.shtml).

AREA OF POTENTIAL EFFECTS (APE)

The Oregon SHPO uses the federal definition of "Area of Potential Effects" (APE) to describe the maximum area that may be affected by a project. Both direct and indirect effects to archaeological sites must be considered when determining the APE. A few examples of project related impacts in an APE beyond the actual construction limits of the project include:

- Borrow areas and other sources of fill material
- Disposal sites or waste areas
- New or upgraded access or haul roads
- Staging, storage, and stockpile areas
- Drainage diversions
- Mitigation areas

Federal definition of the APE:

The geographic area or areas within which an undertaking may directly or indirectly cause alterations in the character or use of historic properties, if any such properties exist. The area of potential effects is influenced by the scale and nature of an undertaking and may be different for different kinds of effects caused by the undertaking. [36 CFR 800.16(d)]

FIELD INSPECTION/SURVEY OR SITE VISIT

A field inspection or site visit begins with a complete pedestrian survey of a project's APE, which is generally related to a specific project and any potential effects to significant sites that may result from the proposed project. The initial surface survey is intended to locate cultural resources, assess local landforms and major or minor environmental features (e.g., level land, relic or current watercourses, slope, rock outcrops, springs, etc.) that may have influenced previous land use. It is important that detailed information is recorded for all cultural resources identified during a project's surface survey. This may be the only time that the locale/site is ever visited so descriptions of observed artifacts, feature descriptions, site size, nature and integrity, site vegetation, and ideas you may have regarding the relationship of a site to local landuse patterns (e.g., historic refuse related to railroad logging camp or homestead) all merit recording. Photographs of the site and diagnostic artifacts, in addition to the creation of a site map should always be completed.

The archaeologist may excavate a limited number of shovel probes to confirm disturbance or soil integrity and to determine the presence of buried intact soil layers. Shovel probes are particularly useful in areas of high probability and low visibility; however, they can also be used on landforms considered to have a high probability with high visibility but the potential for buried deposits exist. Shovel probes are also useful in establishing site boundaries. Archaeologists need to be aware that in Oregon, a state Archaeological Permit is needed before excavating any subsurface probes on nonfederal public lands (e.g., state, county, and city), regardless of the presence or knowledge of any cultural material. When working on federal lands, all archaeologists need to check with the appropriate federal land manager to see if an archaeological permit (ARPA) is needed and what level of recordation their office would prefer (e.g., use of particular forms). On private lands, no permit is needed to conduct probes for site discovery. A state permit is necessary on private lands for any subsurface investigation (i.e., test or excavation units) within an identified site.

Past disturbance that may have seriously affected the preservation of significant archaeological sites must be sufficiently documented to allow for verification. Documentation of disturbance can include photographs, maps, representative core/column samples, and/or construction records. If the project's APE contains a visible historic period archaeological site or historic feature, additional information should be provided (see Appendix A – Establishing Historic Period Significance).

Accurate locations need to be recorded for all discovered archaeological sites. Location data should include a complete legal description (township, range and section) and Universal Transverse Mercator (UTM) coordinates. Use of GPS technology is required with an appropriate GPS datum identified.

MAP DOCUMENTATION

A site plan, if available, should be used as the base documentation map to document the result of the field inspection. If not available, the archaeological consultant should use the best, scaled project map available in conjunction with a hand drawn sketch or other appropriate format. Site location maps should include USGS topographic maps – 7.5-minute scale. All maps should include a legend, scale and north arrow, and be referenced to a permanent, replicable datum. Project area maps should identify sensitive areas, disturbed areas, newly recorded sites, or previously documented sites (identified by Smithsonian site number), relevant landscape or cultural features, and any other relevant information that can assist the client and reviewers in their respective planning, design, and review tasks. Be sure to include a complete legal description (township, range, section, [quarter-quarter]), county, and USGS 7.5' topographic map name in the report.

Additional documentation may include past site plans showing previous construction zones and areas of previous disturbance. All maps should be dated. As appropriate, relevant location information should be recorded using a GPS technology. GPS readings using Oregon State Plane Coordinates NAD 83 or WGS 84 must be provided for each archaeological site (be sure and state which is used). Clients may request map information in different formats such as GIS.

DEFINING SITE BOUNDARIES

Understanding the boundaries of a significant, or potentially significant site is fundamental to designing an appropriate treatment plan for the site to avoid accidentally destroying part of it. Generally, establishing a site's boundaries should occur independently of any other arbitrary sampling strategy if there are ambiguities between the project's impact area and the site's boundaries. Sometimes, a site is suspected of extending into part of the APE that had not been previously identified as sensitive. When this occurs, the consulting archaeologist should inform

the project sponsor and SHPO. The SHPO will request that additional site boundary testing be conducted in the area not originally identified as sensitive.

TREATMENT OF INADVERTENT DISCOVERIES & SITE PRESERVATION

Inadvertent Discovery in the Course of Project Construction

No matter how thorough a pedestrian survey has been, there is always the chance that a site will be inadvertently discovered during the course of project construction. For projects affecting nonfederal lands, the final report should include a plan that specifically addresses the process to be followed in the event of an inadvertent discovery. The intent of such a plan is to have a process in place to expeditiously deal with such discoveries. On federal lands, an inadvertent discovery plan has generally already been established by the federal land managing agency's specialists, in consultation with SHPO, either for the project or through a prior programmatic agreement. Federal projects are subject to different laws and regulations (e.g., NAGPRA) with each land managing agency often having their own procedures regarding how fieldwork is conducted, sites recorded, need for excavation permits, and notification procedures for inadvertent discoveries. Due to the diversity of procedures among federal agencies, such procedures are not addressed in these Guidelines. All archaeologists working on projects that affect federal lands need to work closely with the federal land managing agency's archaeologist to become aware of what steps need to be followed when working on federal lands, in addition to considering state professional standards and guidelines (36 CFR 800.4(b)(1)). For projects on nonfederal land, the Discovery Plan should include the following procedures:

1. The project will stop immediately if previously unidentified archaeological materials, sites or human remains are discovered during project construction.
2. If human remains are discovered, the Oregon State Police, Commission on Indian Services, SHPO, and appropriate tribes will be contacted at the time of discovery.
3. The project sponsor/client, developer, construction company, or project engineer, as appropriate, shall immediately notify a professional archaeologist.
4. The consulting archaeologist shall make a preliminary assessment of whether the cultural material or site is potentially significant, if an adverse effect to the site will result from the proposed undertaking, and if avoidance is not possible, recommend additional steps to mitigate the effect. This assessment and recommendation must be sent to Oregon SHPO for concurrence prior to commencement of any new ground-disturbing activities. Depending on the project, the nature of the discovery, and the statutory jurisdiction, Oregon SHPO may ask the project sponsor to retain a consulting archaeologist to assist in development of a treatment plan. It is important that archaeologists are aware of state permit laws when working on nonfederal public or private lands in Oregon.
5. Depending on the statutory jurisdiction of the project (state law or federal law), the appropriate jurisdictional agency may need to get involved in discussions to resolve the matter in accordance with their respective authorities.
6. If the project falls under federal Section 106 jurisdiction, the process set out in 36 CFR 800.11 and 800.13 must be followed.

Treating an Unanticipated Site Once Discovered

- The project's consulting archaeologist shall conduct a field assessment of the site to determine the site's potential State or National Register eligibility and the project's potential effects to such sites.
- The project sponsor/client may need to hire an archaeological consultant if additional information is necessary to determine significance, site boundaries, and State Register or National Register eligibility. Concurrence of all eligibility determinations should be sought from Oregon SHPO.
- If the site meets State or National Register criteria, the preferred treatment is avoidance and protection in place. Site significance and treatment options based on the nature of the site and the situation should be discussed and documented with the appropriate interested public parties. If site avoidance of a significant site is not possible, then archaeological data recovery of the site may need to be completed if other treatment options are not more appropriate.
- If the project falls under federal Section 106 jurisdiction, construction in the site area will not proceed until it has been reviewed and documented according to 36 CFR 800.11 and 800.13.
- If the project is located on nonfederal public or private land, an expedited archaeological permit must be applied for by the consulting archaeologist and received prior to any ground disturbing activities.
- All data recovery plans should be coordinated through the federal land manager's archaeologist (federal land) or Oregon SHPO (nonfederal public and private land).
- See Treatment of Human Remains Policy (later in this Section) if burials are discovered.

Long Term Site Preservation Through Easements or Fee Simple Purchase

Conservation easements or Preservation Deed Covenants are important tools to ensure long-term site protection for significant sites that can be wholly or partially preserved in-place. The project's consulting archaeologist should recommend a conservation easement or covenant for specific sites both to the Oregon SHPO and to the project sponsor wherever appropriate. The recommendation can be made in the Management Summary of the investigation report for Phase I or Phase II. Conservation easements may be stipulated, or as a condition in a Memorandum of Agreement under Section 106, or may be a voluntary action by the landowner.

In the latter case, the landowner may donate or sell the development rights to the land that contains the site to a non-profit organization (e.g., the Archaeological Conservancy, a local land trust or other non-profit entity). Fee simple purchase of the site by a non-profit entity is another option that ensures maximum site protection. A site map showing the area meriting protection in perpetuity should support recommendations for an easement on the site. Detailed information on conservation of sites through easements (either through purchase or donation) is available at http://www.opb.org/programs/oregonstory/land_trusts/about_trusts/page_4.html and <http://tps.cr.nps.gov/pad/strat1.cfm> or through tax incentives (<http://tps.cr.nps.gov/pad/index.html>). The Archaeological Conservancy specializes in the conservation of important sites through fee simple purchase (<http://www.americanarchaeology.com/aaquis.html>), although local and regional non-profits may also be interested partners. See Appendix B for a sample Preservation Deed Covenant.

CURATION OF ARTIFACTS AND DOCUMENTATION

Archaeological investigations usually result in the retrieval of archaeological materials (artifacts) and production of original data (notes, records, photographs). Artifacts and data are an integral part of the documentary record of an archaeological site and should be curated to ensure their stability and availability for future research. Artifacts that are removed from private lands in connection with a federal action are generally the property of the landowner. Notes, records and photographs generated as a result of a federal action are the property of the federal government, regardless of the location of the archeological site. Provision for the costs of curation may be made a condition to the issuance of a federal license or permit. When the owner cannot provide proper curatorial care, the federal curation standards recommend but do not require that the federal agency seek title to the collection. It is important to note, in Oregon all artifacts recovered under a state archaeological permit must be collected. Reburial of artifacts is not permitted. The place where a project's artifacts and original data will be curated should be determined before beginning any fieldwork. Oregon SHPO encourages placement of collections with the University of Oregon Museum of Natural and Cultural History (UOMNCH or OSMA) in Eugene (<http://natural-history.uoregon.edu/>), the principal repository for archaeological materials recovered from sites in Oregon for all site collections. A copy of their curation guidelines is included in Appendix C.

The National Park Service has established federal curation standards, entitled *Curation of Federally Owned and Administered Archeological Collections* (36 CFR 79), which apply to surveys, excavation or other studies conducted in connection with a federal action, assistance, license or permit. Oregon recognizes the federal guidelines as the established minimum standards for the processing and curation of archaeological collections. These standards should be followed for all collections to be curated under an Oregon State Archaeological Permit. Oregon SHPO recommends adherence to these requirements for all archaeological collections generated in Oregon, in order to standardize curation practices, ensure professionalism in the treatment of archaeological materials, and to assure the availability of collections and documentation for future research.

Any repository that is providing curatorial services for a collection subject to the federal regulations must possess the capability to provide adequate long-term curatorial services, as set forth in 36 CFR 79, to safeguard and preserve the associated records and any material remains deposited in the repository. There is no grandfather clause in the federal regulations. This applies equally to repositories that agree to preserve collections after the effective date (October 12, 1990) as well as repositories that agreed prior to that date. If a repository's officials find that they are no longer able to provide long-term curation, they have the responsibility to consult with the federal agency responsible for the project regarding an acceptable repository for the existing collections.

If a Site is Located on Public Land

All archaeological material collected from federal or state lands or under state waters in Oregon is the property of the public entity entrusted to it. Thus, the land-owning or controlling federal

agency (or designee) or state agency is responsible for ensuring the care and management of all collections recovered from their lands in perpetuity in accordance with federal laws, regulations, and guidelines or under Oregon State Statutes. As mentioned above, the University of Oregon Museum of Natural and Cultural History in Eugene has been designated as the primary state institution that cares for both precontact and historic collections (ORS 390.235(2)). Other public or private museums in Oregon that meet Federal guidelines for curation of archaeological collections (36CFR part 79) may serve as long-term curatorial facilities but such alternative facilities must be approved in advance, in writing, by OSMNCH (see ORS 390.235(2)) and the appropriate tribes (ORS 390.235(1)(b)). Copies of all field notes and artifact catalogs need to be sent to OSMNCH within six (6) months of completion of fieldwork (ORS 390.235(3)(c)(C)) or as approved under the state archaeological permit.

If a Site is Located on Private Land

All archaeological materials (aside from human remains, funerary objects, sacred objects, and objects of cultural patrimony) collected from private land in the course of archaeological investigations are the property of the landowner unless they are explicitly donated to a suitable organization that will care for and manage the collection. It is important that consulting archaeologists inform the landowner of their legal entitlement to the archaeological materials. After the completion of data analyses, if the landowner desires to keep the recovered artifacts they must be returned to the landowner. However, a thorough documentation and analysis should be afforded to important aspects of any data set that are to be returned to a landowner, since they may not be accessible to researchers again. This analysis is included as part of the investigation's final report. After completion of the final report and sending a copy to the appropriate tribes, a thirty (30) day waiting period should be observed before returning the artifacts to the landowner. This waiting period will give the appropriate tribes sufficient time to examine the report and recovered artifacts in order to request the return of any sacred objects or objects of cultural patrimony that may not have been noted by the archaeologist. If a request is made to have such items returned to a tribe rather than the landowner, the archaeologist should fill out a repatriation form and submit it to the SHPO for approval of the University of Oregon Museum of Natural and Cultural History. Such requested items should not be returned to the landowner until the repatriation process has been adequately addressed. See Appendix D for a copy of the *Request for Repatriation of Archaeological Material from Oregon Non-Federal Public and Private Land* form. Consulting archaeologists should always ask the landowner to consider donating any recovered collections to a museum to ensure perpetual access of the collection for future research, education, and public interpretation.

If the archaeological investigation on privately owned land is federal or state funded, and if the landowner relinquishes ownership of the collection, then that federal agency (or designee) or state agency is responsible for ensuring the care and management of the collection in perpetuity in accordance with federal laws, regulations, and guidelines or under ORS 390.235. Donation of a data collection from privately owned land must be documented by letter of agreement or other appropriate document between the landowner and interim or permanent caretaker of the

collection. It is recommended that this letter accompany the permit application so that it is possible to track the collections long term curation.

Donating an archaeological collection and any associated care fee may have potential tax benefits for a landowner. Private developers may wish to consult a tax lawyer or accountant on this possibility.

Treatment of Human Remains

The archeological investigation or treatment of any human remains and burial sites must be undertaken with sensitivity for the wishes of descendants and groups culturally affiliated with the deceased, and must be conducted in full compliance with applicable federal and state law. Careful consideration, thorough planning, and extensive consultation should precede any excavation of burials. If a proposed project area contains or is likely to contain human remains (e.g., based on the proximity of known burials, historical records, oral accounts, or the results of previous investigations), the project sponsor or archaeologist should consult with the Oregon SHPO to determine an appropriate course of action. The consultation process is likely to include the participation of the Oregon Commission on Historic Cemeteries and the Commission on Indian Services (CIS) for precontact burial sites, descendants, culturally affiliated groups, and other interested parties as pertinent to the human remains concerned.

The Federal Native American Graves Protection and Repatriation Act (NAGPRA) (25 U.S.C. 3001- 3013) establishes protection and procedures for the treatment of Native American human burials located on federally owned property or Indian lands. NAGPRA gives certain rights regarding the treatment and disposition of human remains, funerary objects, sacred objects, and objects of cultural patrimony to lineal descendents and to federally recognized Indian tribes when these groups demonstrate cultural affiliation. The law encourages the avoidance and preservation of archaeological sites, which contain Native American burials on federal lands. NAGPRA requires federal agencies to consult with qualified culturally affiliated Indian Tribes or lineal descendants prior to undertaking any archaeological investigations, which may encounter human remains, or upon the unanticipated discovery of human remains on federal land. The consulting parties decide the appropriate treatment and disposition of human remains and other cultural items recovered. This consultation may be a lengthy process and should occur early in project planning.

Current Oregon state burial laws: 1) protect all Native American burials and associated cultural resources (ORS 97.740-760); 2) prohibits abuse of a memorial (e.g., gravestones, tombs, monuments, fencing) to the deceased (ORS 166.076); and 3) outlines the process for the removal of dedication denoting a land's use for cemetery purposes and/or the discontinuance of cemetery and the removal of remains and markers (ORS 97.440 – 450). The law provides penalties for unauthorized removal of human remains and the willful destruction/injury to any cemetery structures (such as a tomb, cairn, monument, gravestone, building, wall, fence, and railing) or vegetation (trees, shrubs, plants). In addition, if a burial is to be disinterred and then re-interred in a different cemetery, a permit must be obtained from the County Health officer or the State Department of Health and Mental Hygiene (Health - General Article, § 4-215).

In general, Oregon SHPO does not encourage the excavation of human remains, unless natural or human forces imminently threaten those remains. However, cemeteries and burials should be located, recorded, and evaluated as archaeological properties when discovered through archaeological investigations.

During a Phase I identification survey, archaeologists should record active cemeteries on an Oregon Commission on Historic Cemeteries Survey form, while abandoned and/or isolated burials and human remains discovered during excavation activities should be recorded on an Archaeological Site Survey form. A Phase II site evaluation should examine the significance of the cemetery/burial by applying the National Register criteria. Phase I and II efforts should utilize non-destructive techniques to determine boundaries, age, cultural affiliation and significance of the cemetery/burial. Such techniques may include extensive background and historical research, informant interviews, thorough visual examination, careful probing, and ground penetrating radar. Excavation of cemeteries and burials is only appropriate for Phase III investigations, and must occur in full compliance with applicable federal and state law and following appropriate consultation with all relevant parties.

Generally, cemeteries and human remains are not considered eligible for the National Register (36 CFR § 60.4). However, cemeteries/burials may be eligible if they are integral parts of a larger historic district or site; if they derive primary significance from graves of persons of transcendent importance, age, association with historic events, or distinctive design features; or if their principal significance is their ability to yield important information. For further guidance on assessing the significance of cemeteries, see the National Park Service's National Register Bulletin 41, *Guidelines for Evaluating and Registering Cemeteries and Burial Places*. If identification and evaluation efforts determine that a cemetery or burial is not eligible for the National Register, the project sponsor/agency should comply with appropriate federal and Oregon law in further treatment of the resource.

If human remains are discovered during a field investigation or project construction on nonfederal lands, the following activities should occur immediately:

1. All work should halt in the vicinity of the discovery.
2. Notify the Oregon State Police in case the human remains are related to a crime scene.
3. Contact the Commission on Indian Services (CIS) to discover the appropriate Tribes for the area of discovery [503-986-1067].
4. Contact all of the appropriate Tribes mentioned by CIS in case the human remains are later determined to be Native American.
5. Contact Oregon SHPO who can help to ensure that the human remains are cared for immediately, that relevant parties agree upon a course of action, and that project activities can recommence while causing no harm to the discovered burial area.

If human remains are discovered during field investigation or project construction on federal lands, the following activities should occur immediately:

1. All work should immediately halt in the vicinity of the discovery.
2. Notify the federal agency archaeologist.

3. The federal archaeologist will contact the appropriate authorities (e.g., State Police, Tribes) as needed.
4. Work with the federal archaeologist to implement federal inadvertent discovery procedures in order to complete the field investigation.

The nine federally recognized tribes in Oregon have written a position paper on the preferred treatment of inadvertently discovered human remains. This position paper is included below.

Treatment of Native American Human Remains Discovered Inadvertently or Through Criminal Investigations on Private and Public, State-Owned Lands in Oregon

Native American burial sites are not simply artifacts of the tribe's cultural past, but are considered sacred and represent a continuing connection with their ancestors. Native American ancestral remains, funerary objects, sacred objects and objects of cultural patrimony associated with Oregon Tribes are protected under state law, including criminal penalties (ORS 97.740-.994 and 358.905-.961). The laws recognize and codify the Tribes' rights in the decision-making process regarding ancestral remains and associated objects. Therefore both the discovered ancestral remains and their associated objects should be treated in a sensitive and respectful manner by all parties involved.

Identification of Human Remains

- Oregon laws (ORS 146.090 & .095) outline the types of deaths that require investigation and the accompanying responsibilities for that investigation. The law enforcement official, district medical examiner, and the district attorney for the county where the death occurs are responsible for deaths requiring investigation. Deaths that require investigation include those *occurring under suspicious or unknown circumstances*.
- If human remains that are inadvertently discovered or discovered through criminal investigations **are not clearly modern**, then there is high probability that the remains are Native American and therefore ORS 97.745(4) applies, which requires immediate notification with State Police, State Historic Preservation Office, Commission on Indian Services, and all appropriate Native American Tribes. To determine who the "appropriate Native American Tribe" the responsible parties should contact the Legislative Commission on Indian Services (CIS). To determine whether the human remains are Native American the responsible parties should contact the appropriate Native American Tribes at the initial discovery. It should be noted that there may be more than one appropriate Native American Tribe to be contacted.
- If the human remains are possibly Native American then the area should be secured from further disturbance. The human remains and associated objects **should not be disturbed, manipulated, or transported from the original location until a plan is developed in consultation with the above named parties**. These actions will help ensure compliance with Oregon state law that prohibits any person willfully removing human remains and/or objects of cultural significance from its original location (ORS 97.745).
- All parties involved and the appropriate Native American Tribes shall implement a culturally sensitive plan for reburial.

Notification

- State law [ORS 97.745 (4)] requires that any discovered human remains suspected to be Native American shall be reported to-
 1. State Police (current contact Lt. Craig Heuberger, Department of State Police, office phone 503-508-0779.
 2. State Historic Preservation Office (SHPO)

- Primary contact - John Pouley, Asst. State Archaeologist, phone 503-480-9164 or john.pouley@oregon.gov.
 - Secondary contact - Jamie French, GIS Archaeologist, phone 503-979-7580 or jamie.french@oregon.gov.
3. Commission on Indian Services (CIS)
 - Current contact - Mitch Sparks, Director, office phone 503-986-1067. Mitch will provide the list of appropriate Native American Tribes.
 4. All appropriate Native American Tribes provided by CIS.
 - Burns Paiute Tribe- Diane Teeman 541-417-1986
 - Confederated Tribes of Coos, Lower Umpqua and Siuslaw- Stacy Scott 541-888-9577
 - Confederated Tribes of Grand Ronde- Briece Edwards 503-879-1630
 - Confederated Tribes of Siletz- Robert Kentta 541-444-2532
 - Confederated Tribes of the Umatilla Indian Reservation- Teara Farrow 541-276-3629, secondary contact; Catherine Dickson 541-429-7231
 - Confederated Tribes of Warm Springs- Christian Nauer 541-553-3464
 - Coquille Indian Tribe- Kassandra Rippee 541-756-0904
 - Cow Creek Band of Umpqua Indians- Jeremy Johnson 541-677-5575 X5577
 - Klamath Tribes- Perry Chocktoot 541-783-2219 X159

III. STANDARD FIELD METHODOLOGY

FIELD METHODS

The following Section outlines standard field practices for archaeological investigations in Oregon. The Oregon SHPO is seeking a common sense approach to archaeological investigations and is open to discussion of alternative techniques and strategies on a case-by-case basis. Alternative approaches should be determined in consultation with the Oregon SHPO and the project sponsor prior to development of the Research Design, or during Scope of Work review.

Surface Survey

An intensive survey means an area has been walked; normally with closely spaced parallel transects of one or more people. An intensive sample survey inspects all the ground in specifically selected areas. The intensity of the survey coverage appropriate in a particular area will depend upon a number of variables. These include: 1) amount and nature of information already on record about sites; 2) types and densities of ground cover; 3) expected potential for, and density of, unrecorded sites; 4) known or estimated minimal size of various site types in the area; 5) specific needs of the survey project (i.e., complete inventory, sample survey, etc.); 6) anticipated use of the survey data (e.g., if the data are to be used for a predictive model, then a higher intensity may be required); 7) anticipated intensity of impacts (i.e., highway or residential construction, as opposed to selective timber harvest); and 8) previous disturbance (e.g., flooding or quarrying). Surface survey transect intervals should generally be no greater than 20 meters apart. Ten meter transect intervals (or less) should be used when intensive survey coverage is required. It is understood that some large land managers have projects that encompass large tracts of land (e.g., timber sale, grazing allotment) where the use of 20 meter transects may not be practicable. In such cases a maximum transect interval of 30 meters can be used.

In general, the less that is known about an area, the more intensive the survey should be, both in terms of percentage of total area looked at and amount of ground actually inspected. The spacing between individuals walking in parallel transects will depend upon the nature of the sites in the area and the needs of the project. For example, if it is known that significant lithic scatter sites are located in an area, that lithic scatters in this area are typically less than 20 m in diameter and the purpose of the survey is to inventory all significant sites, then the space between survey transect interval should not be more than 20 m. If the size of sites is not known, then the space between individuals might start at 10 m and increase only as information about sites increases. Transect interval spacing should generally be based on the goal of the survey – to identify all sites that are potentially significant to the National Register of Historic Places.

Because environmental conditions (ground cover, season of year, and amount of recent rainfall, the nature of the alluvial or colluvial deposits) and modern disturbances may obscure the surface evidence, some technique of subsurface observation (e.g., shovel probes) should be a part of most surveys conducted. Subsurface probes should be no smaller than 30cm in diameter,

cylindrical in shape, and spaced no greater than 20 meters apart. The report on an intensive survey followed by or accompanied by testing should define the amount and kinds of ground looked at and include a discussion of the nature of the sites as determined by the test excavations. It is normally not possible to establish the significance of an individual site without testing to determine the nature of subsurface deposits.

Sites are identified by: surface features such as mounds, embankments, quarry pits, remains of houses or outbuildings, wells, and cellar holes; artifacts or refuse on the surface or recovered in tests; discoloration of the soil which may indicate midden or subsurface features; anomalous occurrences or concentrations of rock, non-native or exotic vegetation, anomalous plant communities (clusters of native cedar or pine in hardwood forest, for example), and/or decorative or domestic plants indicating historic activity; or combinations of the above.

Shovel, soil probe, and/or auger holes and test pits on archaeological sites should be made to determine the nature of the cultural and natural deposits below the surface. Historic archaeological sites, particularly residential (rural or urban) sites, may have successive buried ground surfaces because of filling around the structure and general grading around a house. Testing should be designed to determine this. The nature, placement, and size of such historic scatters (whether on the surface or just below it) should be determined in relation to other above and below ground features and contexts (rock piles, rock walls, domestic flowers, etc). Historic sites may include orchards, fields, etc., which may be located on early maps, discovered from oral accounts or found in archival sources. The general nature of the soil and the matrix in which cultural material occurs should be determined and that information provided in the report. The topographic and environmental setting of the site must be recorded.

Surface surveys on recently plowed agricultural fields may be an appropriate method for efficiently identifying the presence of a site. Walking transects of ≤ 5 meters apart is recommended to find evidence of small sites. To allow for artifact recognition, plowed surfaces should have recently received a minimum of $\frac{1}{2}$ inch of rain to wash dust and soil off of artifacts. In Oregon, use of plowing as an archaeological field method is generally discouraged and should only be used if a plow zone already exists. If plowing the ground surface is being considered as a field investigation method and the surface is not now an (or obviously a previously) open plowed field, and there is no formal records (e.g., USDA Farm Service records) identifying the area as a tilled field, it is necessary to first verify the existence of a plow zone through preliminary subsurface testing prior to plowing. The importance of this has been demonstrated repeatedly: plowing a field that has never been plowed, or plowed generations ago to a shallow depth, can destroy a site. Harrowing a recently plowed field is appropriate; harrowing an old hay field or fallow field may not be appropriate. In floodplains, stratigraphic assessment is necessary to confirm suitability of surface collection as an appropriate method because in such cases plowing may not reach the depth of the precontact deposits. At a minimum, subsurface test pits are necessary to verify depth of plow zone, existence of buried plow zones or cultural levels, and stratigraphic context. In complex floodplains, deep backhoe testing may be necessary to obtain this information. Once it has been confirmed that a field has been plowed and if plowing is selected as the preferred investigative method, the next step is to determine the depth of past plowing so that plowing conducted to facilitate site discovery goes no deeper.

Remote Sensing

Precontact and historic period archaeological sites may be more readily discovered using modern technology such as metal detectors, aerial and infrared photography, ground penetrating radar (GPR), and electro-magnetic induction. These methods may be beneficial to guide the locations and configurations of subsurface testing. Typically, these technologies would be applied during Phase I investigations but can be used in all assessment steps. Remote sensing may not be substituted for standard shovel testing or excavation on terrestrially based Phase investigations.

If large cultural features are anticipated at a precontact site, GPR and electro-magnetic induction may be useful guides to help focus subsurface investigations.

Monitoring

Monitoring project activities may be employed in cases where there is a low probability of remains but inadequate survey has been undertaken; where survey and data recovery has been completed, but there is a high probability that project activities will encounter significant remains that there is reason to believe may still be present; and in cases where project exigencies preclude extended work stoppages. A plan to address resources discovered during monitoring shall be established with SHPO prior to monitoring. Monitoring is normally a field method of last choice. Guidelines for use of archaeological monitoring can be found in Appendix E.

Sub-Surface Testing

Shovel Probe/Test Pit Methodology

The standard shovel probe/test pit interval for subsurface shovel testing is 20 meters. However, expected site size, landscape features, or the research design may require intervals of more or less than 20 meters. For example 5-meter to 10-meter intervals may be appropriate depending on expected site type, micro-topography, results of initial test pits, and other factors.

Shovel probes (i.e., cylindrical holes) are primarily useful in establishing the presence or absence of a site and in determining a site's boundaries. Shovel probes should be a minimum 30 centimeters in diameter throughout the probe. Shovel test pits should generally be square and at least 50 centimeters on a side. Test pits should be excavated within a known site to assist in determining site composition and integrity. All pits should be excavated into the C-horizon (that is, through the full A and B horizons), or until two sterile levels (i.e., 20cm) are encountered below any culture-bearing levels and after extending a minimum of 50cm in depth (unless bedrock or other obstructions prevent going to 50cm). In areas where fill has been placed over native soils or sites are expected to be located much deeper, deeper excavation units are required.

Subsurface testing within a site with defined boundaries should usually be conducted using excavation units at least 50cm square³. However, there may be specific situations where round probes may be more effective than square units. These situations might include projects involving sites that have been defined as containing discontinuous cultural deposits or projects where a recorded site has been heavily disturbed and the presence of subsurface artifacts is in question and needs to be established. Situations where round probes might be considered appropriate within a site area will differ and should be called to the SHPO's attention for review on a case-by-case basis, in consultation with the project archaeologist and subject to approval by the appropriate tribes.

Site boundaries are to be established by excavating shovel probes in no less than four directions. Use of a standard 20m-grid pattern is preferred, however, thirty-meter interval shovel probes can be used to establish the general boundaries, with two consecutive negative shovel probes the edge of the site can be established at the first negative probe. Thus, the interval between two distinct sites will be at least 60 meters. A 10-meter testing interval along each axis is recommended at the outer limits of the site to establish more accurate boundaries. Site boundaries can be tentatively established when at least two consecutive negative shovel probes are excavated using 10-meter intervals. When assessing a site's boundaries, there is no need to probe every 20 meters within an area possessing surface artifacts. The presence of such artifacts is sufficient to verify that the site exists in the area. Subsurface probes should be placed beyond the extent of visible surface artifacts. A few subjectively placed test pits within the area containing surface artifacts may provide sufficient information on the depth of the cultural deposit, general artifact composition, and relative soil integrity.

Soil should be sifted through a maximum mesh size of ¼". One-eighth inch screen mesh is generally recommended for most site investigations in order to retrieve the full range of cultural material present and for the detection of small task-specific sites. Use of ⅛" or smaller mesh is required in special site areas, such as features or lithic workshops, if the research design requires this level of investigation and data collection, and generally in all Phase II and Phase III investigations. Depth provenience should be recorded by soil level if possible or a minimum of 10cm arbitrary levels for shovel probes shovel test pits. Small test pit methodology may be inappropriate for identifying and investigating historic period archaeological sites and is usually inadequate for locating deeply buried sites in floodplains.

Test Units

Larger test units, are generally excavated during Phase II and III investigations when parts of a site need to be intensively studied. In special cases, such as expedited consultation (36CFR800.3(g)), test units may be appropriate during Phase I investigations to examine stratigraphy, accelerate assessment of site character and site significance, and identify historic period archaeological sites, for example. Test units can be of varying sizes, shapes, and depths depending on the objectives of the investigation, type of site, stratigraphy, soils, etc., but will be

³ Oregon's nine-federally recognized tribes have requested that archaeologists try to keep excavation units within a site to a minimum while obtaining the maximum degree of information possible. The use of square excavation units are required for all work within a site in order to meet this expectation. Appendix F summarizes the pro's and con's of using various excavation sized units.

excavated by hand using trowels and/or shovel skimming; features should always be excavated by trowel. Arbitrary levels within soil horizons should be no thicker than 10 centimeters and should differentiate between natural stratigraphic levels when visible. The plowzone may be removed as one unit if reliable stratigraphic data over an area determines that this is an appropriate strategy. Such a strategy would also be appropriate for fill deposits once the level of fill has been established.

Deep Testing

Hand excavation of deeper test units and/or mechanical excavation may be necessary to identify buried cultural deposits in floodplains and other depositional settings. Augers or cores are useful tools for examining deep culture-bearing sediments by extending test units below their maximum depth/level of safety. Mechanical excavations (typically backhoe) have the advantage of being quick, but unless they encounter some obvious cultural deposits, such as a feature, they may not be sufficient to determine whether or not buried cultural deposits exist unless screening is employed as a sample control. Hand excavation of larger test units (for example, 2.0m x 1.0 m or 2.0 m x 0.5m) has the advantage of exposing or identifying cultural deposits, where present, through excavation and sifting of all sediments. In cases where deep testing is warranted, Oregon SHPO recommends that it be consulted during preparation of the research design.

Historic Archaeological Site Recordation

For historic archaeological sites, all structural remains (ruins) and other features shall be recorded and mapped to the same standards as precontact sites. The archaeologist shall attempt to establish site function, length of occupation, and identity or social/economic background of the occupants.

All standing structures over 75 years of age (50 years for federal projects) should be photographed, mapped, described, and the surrounding area evaluated for archaeological potential. The map shall minimally be a schematic plan of the site showing the relationship of all standing structures to the project boundaries, a permanent datum and the terrain. Photographs should be keyed to the map. Note: If an archaeological survey finds no archaeological sites, but standing structures are present that need to be documented pursuant to this paragraph, the following information should be included.

1. This information on standing structures is necessary to assist SHPO staff in determining whether a professional historic architectural survey is necessary. The documentation is not expected to be equivalent to the documentation that would be undertaken by a Historian or Architectural Historian. SHPO Section 106 above-ground documentation forms can be used for recording such structures (see http://egov.oregon.gov/OPRD/HCD/SHPO/preservation_106.shtml).
2. If the investigator knows a historic architectural survey is scheduled for the property or has already been carried out, this information may be omitted upon approval by the SHPO.

3. Historic graves and cemeteries over 50 years of age are to be recorded. Permanent Smithsonian site numbers shall be obtained from SHPO for all archaeological burial areas (i.e., non-active cemeteries). Information regarding all historic graves and cemeteries will be shared with the Oregon Historic Cemetery Commission. If the SHPO determines the grave or cemetery may have potential significance under Criterion A, B, or C the SHPO may request additional evaluation by a historian or architectural historian.

Recording Measurements

In general, all measurements for prehistoric (precontact) sites will be recorded in the metric system. In cases of historic sites, including shipwrecks, English measurements can be reported with metrics in parenthesis.

Establishing a Permanent Site Datum

A permanent site datum should be established with GPS on a potentially significant site at the conclusion of the Phase I investigation so a site can be relocated. If such a permanent datum is not possible (for example, due to landowner concerns, etc.), then additional GPS positions should be taken and recorded for several nearby pre-existing, permanent reference points to help in site relocation. GPS datum and reference points should be illustrated on site maps.

ISOLATED FINDS

An isolated find is an artifact that has been lost or discarded; there is no associated site or feature to provide important information about some past human activity. A single Native American projectile point lost in use comprises a typical isolated find. However, most seemingly “single” precontact artifacts -- such as a flake or scraping tool -- found in a shovel test pit or on the ground surface are not necessarily an isolated find. Rather, they may provide a clue that a site may exist in the area around that artifact. In Oregon, an isolated find is defined as nine or less artifacts.

Treating Isolated or Limited, Surface Artifacts

Precontact period isolated finds identified through systematic surface survey may require, at a minimum, excavation of 2-4 shovel test probes/pits in the area of each surface manifestation (normally ≤ 2 meters away from discovered artifact). The need for and number of additional test pits to be placed in the area of a discovered isolate should be based on the probability of a site existing on the general landform that the isolate is found and the size and extent of the surface concentration. If a single arrowhead is discovered on a greater than 40% slope the likelihood of this tool representing a surface manifestation of a buried significant site would be minimal and therefore would not normally require the excavation of subsurface probes. However, if the arrowhead was discovered on a small bench above a major drainage, it is likely that more substantial deposits of cultural material could exist at the locale and subsurface probes would be

recommended. Subsurface probes also help to reveal soil profiles of area soils providing a window on its depositional history and previous episodes of disturbance. Subsurface probes/pits in isolated find locales are useful in determining the potential for sub-plowzone deposits. This additional information will improve planning for any Phase II field investigation that may be necessary. The use of subsurface shovel probes/test pits to determine if an isolated find is part of a buried site should be based on knowledge of local topography, previous landuse practices in the area and general site types that may be expected.

Some types of potentially significant historic period isolates, for example; those pertaining to military encampments, contact villages or early Euro-American settlement, may also need this type of treatment. Contact period isolated finds may require the excavation of subsurface probes to establish if a buried component is associated with the find. Each case should be examined to determine if this is needed. For example, the discovery of an isolated, discarded amethyst glass bottle would not necessitate the excavation of subsurface probes. On the other hand, a recent discovery along the Oregon coast of an early 18th century gold gorget suggested early contact between Europeans and Natives and highlighted the need for subsurface probes. A thorough background research of the area is essential to interpret historic isolate finds. It is important that the potential significance of all isolated finds is considered during the evaluation process.

Treating Isolated or Limited Sub-surface Artifacts

Positive Phase I test pits that contain ten or more artifacts and are less than 30 meters apart confirm the existence of a site and thus do not need additional sampling during Phase I. A positive test pit, greater than 30 meters from any other positive test pit, that contains a total of nine or less artifacts of cultural materials is considered to be an isolate. In these instances, it is possible to eliminate the need for any subsequent testing by excavating additional test pits at reduced intervals around the original test pit. No further testing is needed provided all additional test pits are negative and a larger unit contiguous with the first test pit produces no new information. If any of the additional test pits are positive, or if other types of artifacts or cultural deposits are identified around the initial find spot, more comprehensive testing may be needed to evaluate the site and assess potential project impacts. Some types of potentially significant historic period sites, for example, those pertaining to military encampments, contact villages, or early Euro-American settlement, may also need this type of treatment.

ARTIFACT COLLECTION POLICY

Pedestrian Survey

Oregon SHPO recommends that collecting should, in principle, be avoided at the survey level. Exceptions may apply in particular cases when archaeological material is considered threatened, rare or worthy of further study. In these cases, the project field director should determine when exceptions occur. In Oregon archaeological permits are required for archaeologists to collect artifacts from sites on non-federal public land or private land. However, OAR 736-051-0090

does permit the collection of an arrowhead from the surface of private land if accomplished without the use of a tool. In lieu of collecting, the following practices are recommended:

1. Detailed field recording should be made of precontact and historic artifacts, particularly where crews may lack adequate training for full assessment of the materials present.
2. Field Records should assess, or allow expert assessment, of site chronology and function (including relevant associations), and include descriptions of artifact types, rough counts, and the range of variability. Sampling may be necessary for large sites.
3. Field Records should include written and visual records, in particular ample photo-documentation (ideally digital). Photos should include site/feature overviews, close-ups of artifact concentrations, and artifact details, with north indicator and scale. Artifact illustrations are highly preferred.
4. In exceptional situations where collecting is deemed necessary all records, including field notes, site forms and reports should:
 - a. specify reasons for making the collection (e.g., emergency situation where artifacts might be threatened by vandalism or destruction);
 - b. provide an inventory of all artifacts collected;
 - c. indicate curation location/provisions.
5. Remember that a state archaeological permit is required to collect such artifacts and should be in place prior to actually collecting any artifacts.

Subsurface Site Discovery Probes

1. In Oregon an archaeological permit must be obtained before any subsurface probing is undertaken on any non-federal public lands. All artifacts discovered under a state archaeological permit must be collected, analyzed and curated.
2. An archaeological permit is not required for site discovery probes undertaken on private land. It is highly recommended that an agreement with the private landowner regarding the curation of any discovered artifacts be made prior to excavating any discovery probes. To insure future research and long-term public access, artifact curation in a federally recognized museum is recommended.

Excavation Units (50x50 cm and larger used in Testing and Data Recovery Projects)

1. When work is being done under a State of Oregon Archaeological Excavation Permit, everything from excavation units must be collected in the field and taken back to the laboratory. All artifacts should be curated following analysis. Modern items may be discarded in the laboratory. State law (ORS 390.235, sub-section 3) requires that everything of archaeological significance, 75 years and older, collected under an excavation permit must be curated.
2. In some circumstances culling of historic material may be acceptable but this should happen in the laboratory and only after consultation with the repository that will be curating the collection. In Oregon this is generally UOMNCH for all precontact and historic collections, or an alternate facility agreed upon by UOMNCH.
 - An exception to the above policy may be made, particularly during data recovery excavations at large historic sites, if the project director obtains an agreement

from the director of the approved repository that allows for culling of some redundant material types in the field (e.g., brick, glass, shell).

- If culling is allowed to be done in the field during excavation the agreement outlining the accepted policy should be in writing and filed with SHPO in the archaeological permit file. Collection and culling policies should be adequately described in the project's final report.
- Decisions on culling of artifacts should not be made in advance of excavation since such decisions are only appropriate within the context of each specific site.
- Culled artifacts should be quantified and recorded, and documentation should indicate where the artifacts were disposed of. It is preferable that artifacts that are culled in the laboratory not be returned to the site for disposal.

3. Oregon SHPO recognizes that Federal agencies have a range of policies regarding collections.

- Some have a "No Collection" policy and others have adopted a variety of approaches to collection strategies and curation, which include culling of some artifact types.
- Although ORS 390.235 applies only to collections made under a State of Oregon Archaeological permit, SHPO recommends that Federal Agencies adopt these proposed recommendations in their approach to culling of historic artifact collections in Oregon.

4. For precontact and historic site excavations the preferred screen size is 1/8 inch mesh. However, other alternatives may be considered, based on site-specific contexts. The selection of screen size should be made by the Project Director and should be included in the research design that is reviewed by SHPO/UOMNCH during the archaeological permit process. Reasons for the decisions on selected screen size (if greater than 1/8 inch) should be explained in the methodology section of the report.

- For precontact and historic sites, coarser mesh may be acceptable when controlled column samples from known features are processed through 1/8 inch and smaller screen mesh.
- Screen size may vary based on soil type (e.g. coarser mesh in wet or clay soils) or recovered artifact types (e.g., beads vs. tinned cans).
- Water screening should be considered where available, with soils having high organic or clay content that hinders screening and recovery.
- In some cases it may be appropriate to evaluate and adjust the screen size strategy (if needed) as an excavation proceeds.

DEFINING PREVIOUS "SIGNIFICANT" GROUND DISTURBANCE

Significant ground disturbance means that ground disturbance occurred to the surrounding area and soils sufficient to significantly alter a cultural site prior to a proposed project/activity. Past plowing, cultivation, and logging do not necessarily constitute "significant" ground disturbance since studies have shown that important cultural information can be retrieved from plow zones and logged surfaces. Deeper deposits such as fire hearths and garbage pits may also exist intact

under the plow zone. In many cases, filling (on land or underwater) may not constitute "significant" ground disturbance since intact, important precontact and historic period sites may lie buried beneath the fill layer. It is important that adequate documentation of all previous disturbances be examined prior to making any recommendations for future actions or site evaluations.

PERMITS FOR ARCHAEOLOGICAL INVESTIGATIONS ON NONFEDERAL PUBLIC AND PRIVATE LANDS

Oregon State Law (ORS 358.905-955, 390.235, OAR 051-360-080 to 090) requires that all field investigations conducted on nonfederal public lands that will require any ground disturbance, and all investigations of known sites on private lands, require an archaeological permit. The Oregon SHPO issues such permits at no cost to the applicant. State lands include all lands owned by any state, county or city agency, including, for example, the Oregon State Departments of Forestry, Parks and Recreation, Fish and Wildlife, and Transportation. Such lands may include state owned historic sites, state and county parks, wildlife management areas, state forests, lands purchased for right of way, or lands purchased to allow for construction of state projects such as highway improvements or new construction. Archaeological permits are required for any surface collections or subsurface field investigation that has the potential of disturbing, destroying, or otherwise altering a site or sensitive area. Permits are not required for non-ground disturbing research activities (e.g., pedestrian surveys, photographic documentation, ground penetrating radar (GPR), and other non-disturbing research). Permit applications and information about the application process can be found on the SHPO [Archaeological Services](#) web page.

Archaeological consultants generally apply for permits on behalf of the applicable state agency or other client. The relevant state agency or client must sign or include written authorization within the permit application agreeing to fund the project through the recovery, analysis, write-up, and curation stages, if artifacts are recovered during the operation of the permit. In accordance with the federal Archaeological Resources Protection Act of 1979 (ARPA), it is illegal to excavate or remove archaeological resources from any federal land without a permit from the federal land manager (http://www.nps.gov/history/local-law/fhpl_archsrcsprot.pdf). Examples of federal land managers in Oregon include the U. S. Forest Service, Bureau of Land Management, Corps of Engineers, Bureau of Indian Affairs, and the U.S. Fish and Wildlife Service, among others. Individual land managers should be contacted for specific ARPA permit application information for their respective lands.

CONSIDERING STANDING STRUCTURES IN THE PROJECT AREA

Project areas may contain historically significant standing buildings or structures. Any building or structure older than 75 years on non-federal or private lands in Oregon may be eligible for

inclusion on, or may already be listed in, the State Register of Historic Places. Any building or structure on federal lands, older than 50 years of age, may be eligible for inclusion on, or may be listed in the National Registers of Historic Places. In the course of routine background research, consulting archaeologists should establish whether any building, structure, complex or district within the project area is currently listed on the State and/or National Registers of Historic Places. These documents are on file at the Oregon SHPO in Salem and will soon be available on our web page. If listed on the State or National Registers, the form (or relevant portion of the form) should be copied and appended to the archaeological investigation report. Relevant historic information available on the State or National Register forms should be incorporated into the background research. Consulting archaeologists are not responsible for evaluating the architectural or historic significance of a structure or district or for assessing project impacts to usable standing structures. An architecturally trained professional should conduct this type of review. However, depending on the project circumstances, if no other documentation exists in the SHPO State or National Register files, it may nonetheless be useful to minimally document buildings and structures within the project area. The consulting archaeologist should discuss with the project sponsor/client the necessity and benefits of compiling minimum documentation on buildings or structures within the project's APE.

While judgments about a structure's architectural integrity and historic significance will be made by qualified professional architectural historians, the archaeologist, on the other hand, may be able to contribute useful and important information on the structure's history and historic context(s). Depending on the Scope of Work and project circumstances, it may be necessary or desirable for the consulting archaeologist to complete the locational and descriptive sections of the Oregon Historic Sites and Structures Survey form and photograph each building or structure if no State or National Register documentation exists. This documentation should be appended to the investigation report. Both descriptive and historic information should be summarized in, or fully incorporated into, as appropriate, relevant sections of the study report. When appropriate, the Research Design for the archaeological investigation may require subsurface testing in the perimeter of the standing structure to identify and evaluate potentially significant archaeological resources associated with the structure. Archaeological investigations around a structure should only be undertaken if they have a high likelihood of providing important new information on the structure or complex. If appropriate, recommendations should be made in the investigation report for amending the existing State or National Register forms.

INVOLVING THE PUBLIC

The regulations (36 CFR 800) that implement Section 106 of the National Historic Preservation Act require enhanced public participation as early as possible in project planning (see various examples at <http://www.achp.gov/work106.html>) . Section 800.2 (d) of the regulations requires that the federal agency or its delegate (sometimes the archeological consultant) seek and consider the views of the public. The following list identifies some of the individuals, organizations, and groups who may have an interest in the proposed undertaking and in potentially affected historic and archeological resources. This list is not exhaustive. In accordance with 800.2 (d) (1), the extent and nature of the "public" should reflect, among other

considerations, the scale and complexity of the project and its effects, the relationship of the federal government to the project, and likely public interest or controversy. The Oregon SHPO can assist in identifying potential “public” that may have an interest in the project.

- Certified Local Governments. Contact information and a current list of Oregon towns with a CLG can be found at <http://egov.oregon.gov/OPRD/HCD/SHPO/clg.shtml>.
- Historical societies. The Oregon Historical Society maintains a list at their web page: <http://www.ohs.org>.
- Non-Profit Organizations. Examples include the Archaeological Conservancy (www.americanarchaeology.com/aaabout.html), local land trusts (see <http://mckenzieriver.org>), The Nature Conservancy (<http://www.nature.org/>), etc. Also see Special Interest Organizations, below, many of who are non- profits.
- Special Interest Organizations. Examples include the Historic Cemetery Commission, Historic Trails Commission, Oregon Heritage Commission, Oregon Cultural Trust, Washington Chapter of the Civilian Conservation Corps, etc. Most of these organizations maintain web sites that can be consulted for contact and other information.

UNDERWATER ARCHAEOLOGY

Oregon possesses a diverse range of submerged cultural resources, ranging from canoes and pirogues to steamboats, schooners, ocean-going vessels, and aircraft, as well as precontact sites inundated through dam construction and coastal subsidence. These sites receive the same level of protection as do terrestrial sites but guidelines as to how to conduct such studies differ. Refer to Appendix G for Guidelines on how to conduct Underwater Archaeological projects in Oregon.

IV. ARCHAEOLOGICAL FIELD INVESTIGATIONS⁴

LEVELS OF INVESTIGATION

There are three levels of documentation for cultural resources. The first two levels constitute components of what is defined in the federal standards as an "intensive" survey. This is different from a "reconnaissance" survey. Although defined in the federal standards, a reconnaissance level survey is not appropriate for projects submitted for review pursuant to Section 106 unless otherwise agreed upon by the Oregon SHPO and the project sponsor/client. For practical purposes the Oregon SHPO has divided an intensive survey into two levels: identification (Phase I) and evaluation (Phase II). The third level (Phase III) constitutes treatment for significant resources. Oregon SHPO normally does not recognize additional division into sub-phases (i.e., Phase Ia and Phase Ib). Each phase is defined briefly below.

RESEARCH DESIGN: ALL PHASES

The Research Design is the core of any archaeological investigation. The archaeological research design describes the research questions being asked, the kinds of data that can be used to answer the questions, the kinds of sampling and field methods that will best locate and recover the data, the most relevant techniques of data collection and analyses, and how the results will be evaluated in reference to the expectations. Most federal archaeological fieldwork is associated with proposed land development projects that often have no primary research questions except to seek to identify and avoid any potentially significant sites within a project's Area of Potential Effect (APE). For such projects, the selected research design will often be general in nature and based on the likelihood to find particular site types that have been identified as likely through the field background research. Data recovery investigations, on the other hand, seek site-specific information on the history and importance of a particular site that is being tested. Answers to very specific questions are sought during such investigations. It is important that all investigations incorporate an appropriate research design.

Standards for Preparing Research Designs: All Phases

All Research Designs should meet the following standards.

1. Research designs must reflect the nature and scope of the project, the types of sites expected or known, potential impacts to significant sites, and other relevant factors.
2. Proposals should focus on the project area; on background research relevant to understanding the project area and sites it may contain; and on expected, or known, significant sites that may exist within that project area.
3. An appropriate level of research should be completed prior to developing the Research Design for any phase of investigation as a foundation for the task.
4. Research designs must meet *The Secretary of the Interior's Standards and*

⁴ This Section largely addresses archaeological investigation on terrestrial sites. For guidelines on investigating underwater sites refer to Appendix C.

Guidelines for Identification, Evaluation, and Archaeological Documentation (Standards and Guidelines) (see http://www.nps.gov/history/local-law/Arch_Standards.htm). The basic expectation for any Research Design is modeled from the *Standards and Guidelines*. These guidelines describe the federal expectations and set forth additional requirements.

5. Phase III Research Designs must be guided by the Advisory Council on Historic Preservation's *Recommended Approach for Consultation on Recovery of Significant Information from Archaeological Sites* (see www.achp.gov/archguide.html).
6. Investigation methods must be selected that are most appropriate to expected site types and their potential significance.

The following questions can help guide choices of methodology:

- What don't we know about a particular site type?
- What types of information are worth learning about?
- Can we gain such information from this site?
- What are the best methods to achieve that learning?
- Is excavation necessary to learn from this site?
- What types of information are available that can tell us more about this site without digging?

PHASE I INVESTIGATION: IDENTIFICATION STUDY

Federal regulations that implement Section 106 of the National Historic Preservation Act refer to "identification of historic properties." The federal, legal definition of "historic property" is "any prehistoric (or precontact) or historic district, site, building, structure, or object included, or eligible for inclusion in, the National Register of Historic Places..." (36CFR800.16(1)(1)). Thus, the goal of "identification" studies under the federal process is to locate National Register eligible (i.e. "significant" or "important") sites.

Practical considerations generally necessitate that archaeological investigations be divided into separate, sequential phases. The intent of the phased approach is to provide a practical framework for estimating the cost of finding a site and, then as a second step, for gathering additional detailed information for evaluating a site's significance. If a site can be determined significant at the completion of Phase I, it should be. If identifying and evaluating a site's significance is practical as a single step for a particular situation, then that should occur (i.e., 36CFR800.3(g)). The Guidelines emphasize the SHPO's goal of determining site significance as soon as is possible, based on available evidence, using the considerations discussed in Section II. Accordingly, the Research Design requirements for Phase I require definition of what is potentially significant, as non-significant sites are not considered further under the Federal consultation process.

Goals for Phase I Investigation are:

- Locate archaeological sites potentially eligible for the State or National Registers that may exist within the proposed project area, or

- Meet the objectives of the Research Design.

A thorough background review is conducted before beginning a Phase I field investigation. Supplemental background research is often important after completing fieldwork to better understand what was found and why it may be potentially significant.

Research Design Requirements for Phase I

The goal of the Phase I Research Design is to find sites that are likely to meet the National Register criteria and describe appropriate methods to find such sites. The Research Design describes the types of significant sites that are likely to be found within a given project area and the kinds of specific data likely to be found in such sites. It should outline basic research questions that can be addressed by this data, known comparable types of sites and their data, and why finding such sites can contribute to our knowledge of Oregon precontact and/or history. Research Designs are an essential part of a project's Scope of Work.

Conducting Background Research

The Research Design and Scope of work help define the extent of background research needed, potential impacts of the project, characteristics of the project area, and types of resources expected. For example, detailed information about the region's physiographic landscape, climatic change, past and present fauna and flora, and other environmental topics should be presented only if it has direct relevance to the project area's potential precontact or historic site values and expected site types.

Archaeological research should relate to addressing and refining relevant research questions. The use and development of historic contexts may prove advantageous in identifying future research questions in need of focus or refinement in the evaluations of particular site types (e.g., logging camps, CCC camps, gold mining operations, 19th century cattle ranches). Where appropriate, research can also relate to other local, regional, or national historic contexts, research questions, and issues. The Secretary of the Interior's Standards and Guidelines for Identification discuss the role of identification in planning and should be used for guidance (http://www.cr.nps.gov/local-law/arch_stnds_0.htm). The SHPO has developed additional guidance that should be used, where appropriate: see <http://egov.oregon.gov/OPRD/HCD/ARCH/index.shtml>.

Data sources that should be checked for all projects include:

1. **SHPO Database**⁵: (contains available site & survey data, GLO maps and ortho-photos. A future version of the database will include a Donation Land Claim [DLC] layer as well as historic aerial photos (e.g., 1930).
2. **General Land Office (GLO) Survey Maps** and notes: earliest record of systematic survey across each land section. The on-line SHPO GIS database contains a composite layer of geo-rectified statewide GLO maps. Individual GLO maps are only

⁵ Data sources marked in bold are considered primary sources that should be consulted for all projects. Non-bold underlined sources are considered secondary sources and are encouraged to be checked when available.

available in the SHPO database within the Salem office. BLM provides access to both maps and surveyor notes

3. **Sanborn Maps** (if working within a town of any size):
4. **Historic Aerial and Orthographic photos**: Early photos provide a visual record of change over a landscape through time (check US Army Corps of Engineer's Portland office for archive photos of your project area). Historic photographs can often be found at local museums, historic societies and the Oregon Historical Society museum in Portland. Aerial photographs as early as 1930 are known to exist for the Columbia River, Oregon coast and much of the Willamette Valley.
5. **Property Title Search**: Useful for tracking change of ownership of land parcels through time. Records readily available at title offices and city halls.
6. **Historic Records**: Diaries, journals, photographic collections, ethnographic and ethnohistoric documents can often be found in local libraries, museums and historic societies.
7. **Oral History**: When available, interviews with area elders and knowledgeable people (both native and non-native) should be considered a valuable resource method. Important information on potential site locations, land use patterns, and historic disturbances may be provided by local artifact collectors, historical society members, landowners, Native Americans, and other community members, as appropriate to the research design, extent of the project, the characteristics of the project area, and other relevant factors (see SHPO web page for recommended guidelines for conducting oral interviews - http://egov.oregon.gov/OPRD/HCD/ARCH/arch_oral.shtml).
8. **Federal Archives, Sandpoint Washington**: Federal archives may provide supplemental historic data on federal lands, in addition to census data, timber surveys and other historic maps.

PHASE I FIELD INVESTIGATIONS: FIELD STUDY

The Goals of the Phase I Investigation include:

- Conduct intensive background research.
- Identify and rank areas of archaeological sensitivity.
- Identify visible archaeological sites or other indicators of the presence or absence of sites.
- Identify and document extent of prior significant ground disturbance.
- Identify potential archaeological issues that must be considered during project planning.
- Establish, if possible, whether or not any evident sites have a high likelihood of being eligible for the State and National Registers.

To accomplish these goals, it is important that an archaeologist conducts the appropriate field investigations described in their Research Design. Field investigations may include, but are not limited to, surface survey, sub-surface testing, remote sensing studies, and combinations of these or other field techniques (see Section III);

- 1). Preliminary field investigations may sometimes be required specifically to identify stratigraphic or other conditions within the project area. For example, backhoe trenching is often necessary in floodplains to identify the depositional history and relative age of the landform and expose possible buried cultural layers;

- 2). Depending on factors such as the scope of work, known or expected site types, environmental characteristics of the project area, and so forth, interdisciplinary field investigations using soil scientists, geologists, biologists, architectural historians, historians, etc., may be required. The Research Design should anticipate and include such interdisciplinary expertise;
- 3). Oregon SHPO expects that considerations of site significance, to whatever extent possible based on existing data, are integral in all aspects of archaeological assessment, from the preliminary background research, through Research Design development, and during the Phase I investigation;
- 4). Determination of site "presence" or "absence" is not a satisfactory result of Phase I investigation. Phase I site documentation should provide enough information to recommend: treatment (for example, site avoidance); additional background research; recovery of additional information to gain a preliminary evaluation of site size, character, and significance; or, if there is sufficient evidence, a determination that the project will not affect a significant site;
- 5). In cases of limited artifacts or site evidence, it is difficult to understand the site type, extent, and its potential significance or to make any kind of recommendations in the absence of additional information. Thus, isolated or limited surface or sub-surface artifacts must be evaluated further at this phase;
- 6). If identified, potentially significant sites will be avoided by project re-design after this phase of study, site documentation at the conclusion of Phase I must, at a minimum, provide a clear, mapped delineation of each site's spatial boundaries in relation to the locations of proposed project impacts. If this is not possible, Phase II investigation will most likely be necessary.
- 7). As sites are found in the field, the archaeological consultant should request Oregon Smithsonian inventory site numbers from Oregon SHPO with their submission of an Oregon site form. The Smithsonian site number should be incorporated into field notes and used on cataloging forms, in databases, on photo identification sheets, project maps and illustrations, in all project reports and other documents, and in the course of collections care and management.

In order to complete the Phase I investigation, the following field methods may be employed:

Surface Survey: An intensive survey means an area has been walked, usually with closely spaced parallel transects of one or more people. Survey transect intervals of $\leq 20\text{m}$ are generally recommended. An intensive sample survey inspects all the ground in specifically selected areas. The intensity of the survey coverage appropriate in a particular area will depend upon a number of variables:

- 1) Amount and nature of site information already available;
- 2) Kinds and densities of ground cover;
- 3) Expected potential for, and density of, unrecorded sites;
- 4) Known or estimated minimal size of various site types in the area;
- 5) Specific needs of the survey project (i.e., complete inventory, sample survey, etc.);
and

- 6) Anticipated use of the survey data (e.g., if the data are to be used for a predictive model, then a higher intensity may be required).

In areas of high probability and low visibility, subsurface probes should always be used to assess the potential of buried significant archaeological sites. When heavy ground cover (e.g., pasture or forest) precludes normal visibility of either artifacts or features, some method (e.g., shovel tests, rakes, surface scrapes) must be used to insure that there is a reasonable opportunity for the surface and/or subsurface deposits to be exposed (the interval for this exposure should be ≤ 20 meters).

Local informants should always be sought for information on artifacts and features, which may have been observed in the past and on historic features, buildings, or individuals known to have used or occupied the area.

Surface Collections – Surface collections are generally not appropriate during Phase I surveys. Whenever possible your field methodology should seek to collect sufficient information from surface artifacts without collection. For surface collections, a representative sample of diagnostic and non-diagnostic artifacts should be collected during later phases of investigation.

Site Discovery Probes/Tests - Shovel probes may vary in shape, size, and depth, but should not be smaller than 30 cm in diameter and shallower than 50 cm. The depth of the pit should terminate at sterile subsoil (i.e., after two (2) sterile 10cm levels) or 100 centimeters below surface (cmbs); whichever comes first. In upland soils, sterile subsoil is usually reached between 40 and 60 cmbs. In marsh soil, deeply buried deposits may exist at depths greater than 100 cmbs. Reaching these deposits with standard shovel tests may be impractical and uneconomical. Auguring and coring should augment shovel testing. Within agricultural fields, finding no remains below the plow zone does not necessarily mean that no intact deposits remain. Standard shovel testing can miss deep or isolated features such as trash pits and hearths. A description and full justification for the determination for the depth of shovel tests is required in the draft and final reports. Representative soil profiles should be drawn and/or described for shovel tests conducted during the course of the survey. The soil profile for at least one shovel test excavated at each site should be drawn and/or described.

Spacing of transects and shovel tests will be variable depending on probability zone (high or low), surface visibility and the phase of investigation. As described in Section III, for Phase I surveys in large high probability-low visibility zones, parallel transects should be spaced no farther than 20 meters apart and shovel tests should be excavated at least every 20 meters along each transect. Smaller high-probability zones potentially subject to direct impacts should receive coverage and testing at a higher intensity. In low probability zones, parallel transects can be spaced up to 30 meters apart and shovel tests should be excavated following an agreed upon methodology for expected site types. If in doubt regarding subsurface probe intervals, consultation with SHPO is recommended.

When delineating site boundaries during Phase I investigations, shovel probes/tests should be excavated in a grid (oriented along cardinal directions or local topography) at ≥ 20 meter intervals on sites less than 50 meters across, and at ≥ 30 meter intervals for sites more than 50

meters across. At sites with a surface scatter of artifacts, shovel probes/test pits should be excavated from beyond the observed/anticipated site boundary towards the anticipated interior. When cultural materials are encountered, locate an additional test unit midway back to the last previous unit to define the boundary. Shovel tests should continue until two consecutive negative shovel tests are encountered. At sites where there is little or no surface indication of a likely site boundary (e.g., a buried site encountered during subsurface discovery probing), units should be excavated in four directions away from the known location of artifacts. Subsurface testing should be conducted at all sites for the purpose of boundary definition, regardless of surface visibility. When delimiting site boundaries in Phase II investigations, intervals of 5 or 10 meters are often appropriate, depending upon the intensity of previous shovel testing and the size of the site.

All material from the shovel probes/tests should be screened. One-eighth inch (3.2mm) screen mesh is generally recommended for all subsurface testing within a known site's boundaries in order to gain a maximum amount of information from all site disturbances. Should it not be feasible to screen the excavated material due to soil conditions, the material should be broken up with a trowel and examined. Shovel probes/tests should be dug using, at a minimum, controlled arbitrary levels no greater than 10cm. A change in mesh screen size (e.g., ¼ inch (6.4 mm)) or arbitrary levels should only be considered after there is a clear demonstration that a larger size is appropriate.

Oregon State law/SHPO requires that all material recovered from shovel tests and test units be collected and curated. The exceptions are materials such as brick fragments, gravel, shell, fire-altered rock (FCR), and unidentifiable metal, which at a minimum should be weighed and described with a minimum 10% representative sample (or approved sampling methodology outlined in the excavation research design) of the latter collected and curated. If total collection of an artifact type is known prior to commencing fieldwork this policy should be described and approved in the project's state archaeological permit (for non-federal lands). If later discoveries during fieldwork suggest such a change, approved will be needed by the University of Oregon Museum of Natural and Cultural History, the state's recognized cultural resource curation repository prior to the change in methodology and a record of this change sent to SHPO to be placed in the archaeological permit record file.

Auger Tests - Soil core augers, soil probes, bucket augers, or posthole diggers may be employed when deep deposits are encountered or suspected or when other factors prohibit shovel testing. Material from auger tests must be screened. Auger tests are not a substitute for shovel tests, but rather should be considered as supplementary for purposes of detecting culturally modified soils only. Due to the extremely small volume sample obtained by augering, the minimum auger size is 15cm/6 in. Artifact volumes cannot be reliably estimated from auger sampling.

Excavations - Excavations refer to subsurface testing with standard manual techniques in units that typically measure 50cm x 50cm, 1 x 1 m or larger. Excavation units larger than 50cm x 50cm are generally not part of Phase I investigations, however, some consultants prefer to excavate larger units in sites at the time of discovery in order to make initial assessments of site eligibility. On small sites, such efforts may prove sufficient to establish site significance and the need for future consideration. All excavation units should be dug in controlled and natural or

arbitrary stratigraphic levels. Levels should not exceed 10 centimeters. Appropriate and representative wall profiles and level plans shall be recorded.

A standard 1 x 1 m excavation unit may be adequate to provide information on stratigraphy, depth of deposits, and a sample of artifacts and features. However, one excavation unit is rarely ever adequate in large sites for Phase II or Phase III work. The plan for the number, size, and placement of Phase II and Phase III excavation units should be within the Research Design discussed with SHPO (i.e., in Archaeological Permit) prior to commencing field investigations.

If human remains are discovered during testing, all work must stop immediately and the State Police, SHPO, Commission on Indian Services (CIS), and all appropriate Tribes need to be contacted. All burial related data must be observed and recorded in the field and the information included in the final report. Fieldwork operations should follow a predefined protocol for the discovery of human remains. If human remains are Native American, coordination and consultation with all appropriate tribes must take place during all phases of the investigation. Because it is likely that human remains will not be available for additional or future study, the observations made during each data recovery project, both in the field and in the forensic laboratory, must be as complete as current techniques and interpretations allow and consistent with the highest standards of modern forensic studies. In addition, the stipulations of PL 101-601 (Native American Grave Protection and Repatriation Act) must be followed if the project is funded through federal law or regulation.

Backhoe - Backhoe and other large earth-moving equipment can be a quick, cost-effective way to determine the horizontal and vertical location of deposits and features. The use of such equipment should normally be restricted to Phase III investigations when prior standard methods of testing have failed to yield features or undisturbed deposits and is generally not appropriate in Phase I investigations. Because testing with earth-moving machinery may destroy large areas of deposits, the use of the machinery should always be weighed against the possible effect on sites.

Monitoring - Monitoring following the completion of Phase I efforts is usually recommended in areas where survey and subsurface probes have proven negative, but there remains a high probability that project activities will encounter significant remains; in cases where there is a low probability of remains but inadequate survey has been undertaken; and in cases where project exigencies preclude extended work stoppages. Monitoring is normally a field method of last choice.

Remote Sensing - Remote Sensing is used to augment more traditional survey methods by identifying high potential areas for subsurface testing. Remote sensing (e.g., metal detector, proton magnetometers and ground penetrating radar) may be used in addition to shovel testing and excavation to aid in the identification of feature and artifact concentrations and the location of sites. Remote sensing may be particularly useful on historic and underwater sites where standard field techniques are inappropriate or excessively labor-intensive and may be used in lieu of or in combination with standard field techniques. Remote sensing may not be substituted in toto for standard shovel testing or excavation on terrestrially based Phase investigations.

Special Samples – Consideration should be given to appropriate special sample (e.g., soil,

pollen, zoological, Cross-over immunoelectrophoresis (CEIP), paleobotanical, coprolite, phytolith, radiocarbon, thermoluminescent, archaeomagnetic, obsidian sourcing, and obsidian hydration) collection techniques, provenience, and curation, which must be described in the final report.

DATA ANALYSES & REPORTING

Data Analyses is normally limited in Phase I investigations due to the limit of subsurface activity and recovery incorporated in this phase of investigation. However, regardless of whether or not the project is pursued, the project sponsor is responsible for ensuring that data analyses are completed once any artifacts, other cultural materials, and other types of data are recovered. The consulting archaeologist is responsible for conducting appropriate analyses and interpreting the data that tell the story of the site. The anticipated data analyses described in the Research Design are the basic analytical tasks that will be conducted subsequent to the field investigation. The tasks set forth in the Research Design are obviously based on the expected types of sites. The Phase I recovery of sufficient carbon or obsidian for temporal or sourcing analyses should be anticipated within the research design.

Reporting Guidelines can be found on the Oregon SHPO webpage (http://www.oregon.gov/oprd/HCD/ARCH/docs/Reporting_Guidelines_FINAL.pdf) and are generally not incorporated here. However, it is important that field maps record all shovel tests and/or survey transect locations, site datum and boundaries, project boundaries, and natural and cultural features. The use of mechanical or laser transits, compass, LORAN, GIS, tape measures, or estimating distances and directions are appropriate as long as the instruments used are specified in the final report. Location of sites, shovel tests, and/or transects may be overlain on 7.5' USGS quad maps, remote sensing maps, sketch maps, blue prints, SYMAPs, piece-plotted diagrams, or other maps, but 7.5' USGS maps showing the project and site locations should be identified in the final report. All maps should contain a north arrow, legend, and 7.5' map name/date.

PHASE II INVESTIGATION: EVALUATION STUDY

The following are supplementary requirements for Phase II.

Goals for Phase II Investigation are:

- Conclusively establish whether or not a site meets the criteria for inclusion in the National Register of Historic Places, if not known at the conclusion of Phase I.
- Meet the objectives of the Research Design.

Research Design Requirements for Phase II

The Phase I objectives serve as the core requirements for Phase II investigations. A Phase II investigation may be necessary to gather additional information about a site's characteristics, site significance, and the project's potential impacts to the site. The goals of the Phase II investigation are to gather additional information on a site's character, integrity, condition, size

and boundaries, stratigraphy, structure, function, and context(s) at a detail sufficient to evaluate its significance. If not previously determined, this phase of investigation will conclusively determine whether or not the site meets the National Register criteria.

Field investigations at a historic period archaeological site should not be conducted until thorough background research from traditional historic sources, including oral history, has been completed. The Oregon SHPO considers thorough background research mandatory in developing the final Research Design for the field investigation component of any study. Historic research is essential for framing important research questions, understanding data categories that may be present, designing appropriate methodologies to recover those data, and understanding potential site significance. If appropriate, the background research and the field investigation can be developed as two separate Research Designs, the latter depending on the results of the background research.

The Phase II Research Design should:

1. Meet the Research Design Standards.
2. Include the Phase I Research Design requirements.
3. Include the following:
 - a. Provide a detailed discussion of project objectives, research topics and research questions, and expected results. Research topics and questions must address and refine priority research topics and associated historic contexts or other relevant sources of information.
 - b. Provide a detailed discussion of the proposed background research needed to obtain comparative information on potentially relevant site types, data categories, and necessary local and regional contexts.
 - c. If archaeological field investigations are warranted, describe and justify the sampling strategy, field methods, and intensity of investigation at each site to be investigated based on the site type, expected data categories, project and research objectives, and research questions.
 - d. Discuss the care and management for the recovered archaeological collections, including field notes, other records, artifacts, and other data categories to be recovered. Discuss how large volumes of redundant data, such as construction materials at a historic site, will be treated. Discuss potential discard options for expected categories of artifacts or other data types (e.g., bricks, shell, nondiagnostic metal fragments).

In order to determine the significance of a site, testing often must be done to establish the nature of the potential information that will answer research questions identified in the research design. For example, the fact that there may or may not be undisturbed deposits of cultural material beneath the plow zone is not in itself enough to say the site is or is not significant (see Appendix A on Establishing Site Significance). The archaeologist must balance the need for obtaining adequate information concerning the potential of the site to answer research questions with avoiding a major impact on the site by the test procedure itself.

If non-significance is to be established for precontact sites, subsurface tests must be made on all sites, even if visibility of ground surface is good. Testing of historic sites to determine significance needs to be evaluated against collected background research and the site's potential

to yield significant information on area history. Testing should also be done if ground visibility is poor, there are no surface indications of a site but the location is ideal (e.g., natural levees), or if inspection of modern landscape features suggests the possibility of buried surfaces or deposits that may contain cultural material. Different kinds of tests can provide different kinds and amounts of information on site structure, content, integrity, and quality.

Field Investigation and Data Analyses

Field methods should be chosen and implemented to satisfactorily meet the Phase II objectives. These may include, but are not limited to, additional shovel test pits at reduced intervals, block excavations around features and artifact concentrations, deep testing, and remote sensing studies. Recovered data will be analyzed and interpreted using appropriate techniques and theoretical frameworks for the purpose of addressing the research questions. Analyses of data recovered during the Phase I study will be integrated into the Phase II analyses, findings, methodological assessment, and interpretation of findings. Additional analyses, or even re-analysis, of some or all of the Phase I data may be necessary at this level of study. For precontact archaeological sites, radiocarbon (C14) dates should be obtained whenever possible at this phase of investigation. In all cases in which precontact sites are being studied, Phase II budgets should include costs for radiocarbon dates in anticipation that suitable dating material will be recovered. The inclusion of funds for CEIP analysis, obsidian sourcing and hydration should also be listed.

Field Methods

Shovel Tests/Probes: Shovel tests/probes may be appropriate to refine site boundaries during Phase II or to discover the depth of plow disturbance and the presence and condition of deposits just below the plow zone. Shovel tests/probes also provide similar below-surface information in areas where there is no plow zone, but where the surface of the site is obscured. These tests are usually ≥ 30 cm in diameter (50cm x 50cm preferred) and should be at least 50 cm deep (unless bedrock is found or the nature and integrity of a site can be determined before that depth is reached). Square test units, no smaller than 50cm in width, should be used within the established boundaries of a site (as per request of Oregon tribes). The SHPO should be consulted if there are special circumstances where other types of units (i.e., round probes) might be more appropriate for specific investigations. These situations will be reviewed by the SHPO on a case-by-case basis, in consultation with the project archaeologist and subject to approval by the appropriate tribes.

When cultural material is encountered, shovel tests/probes should extend through at least two (2) sterile 10cm levels before stopping. One-eighth inch (3.2mm) screen mesh is generally recommended for all subsurface testing within a known site's boundaries in order to gain a maximum amount of information from all site disturbances. This smaller mesh size should be used for all site testing until testing demonstrates it to not be necessary (i.e., appropriate artifact classes demonstrated to be within site suggest use of a larger screen mesh [¼ inch (6.4mm)]).

Finding no cultural material below the plow zone in shovel tests does not necessarily indicate that all evidence of past human occupation is in the disturbed plow zone, for there may be many features (trash pits, storage pits, and fire hearths) elsewhere on the site that might not be

encountered in shovel tests. There may also be buried cultural deposits deeper than the depth of completed shovel tests. When shovel testing a site where there is material on the surface, a general guide is for the space between tests to be ≤ 10 m. When shovel testing an area with heavy groundcover where a site is suspected, test holes can be farther apart (15-20 m). Details of the testing and justification for the spacing and number of tests must be provided in the report.

Test Pits or Control Columns: Test pits (e.g., 50 cm x 50 cm, 1 m x 1 m, or 1 or 2 m x 50 cm) are appropriate for looking at the subsurface deposits of a site in order to establish site significance/eligibility. If a concentration of prehistoric artifacts or a historic feature is observed on the surface, a test pit in that area is appropriate. At least one such test pit should provide information on stratigraphy, depth, and a sample of artifacts in context. If there is already a pothole or a natural erosional feature, cleaning the profile of that hole or eroded area may also provide a look at the stratigraphy. Such profiling may suffice for subsurface information on small sites, thereby eliminating need to impact the site further. A single test pit, however, will not always determine the full nature of the subsurface deposits on large and/or multi-component sites. More than one test pit in different areas of large sites may be appropriate for site evaluation and is necessary for determining adequate mitigation measures. Establishing eligibility of a large site based on one 1 m x 1 m test does not provide an adequate sample for planning mitigation measures or budgets.

If human remains are discovered during subsurface testing, the procedures outlined in the [Phase I discussion](#) need to be followed.

If human coprolites are discovered and DNA analysis will be needed, please refer to Appendix H for a protocol on how such artifacts should be collected.

Other Methods: For a discussion of other field methods that may prove effective during Phase II investigations (e.g., use of backhoe, remote sensing, monitoring) refer to in the earlier Phase I investigation component of these guidelines. A backhoe trench can be an efficient quick way to get a soil profile where shovel and test pits seem inconclusive, to search for suspected buried deposits too deep for shovel or auger techniques, and to verify the absence of intact deposits where disturbance appears complete. The geomorphological information to be gained from such a trench may be important in establishing age of deposits or context of multiple components, etc. For example, the nature of artifacts that are found on the surface in an area known to have been subject to large-scale periodic flooding may not be able to be defined by shovel, auger and test pits. Testing with a backhoe may prove beneficial in order to expose general soil construction processes, in addition to their usefulness in locating suspected features that have not revealed below ground cultural material using other methods. The amount of testing with a backhoe must be weighed against its impact on the cultural deposits or other relevant project factors. The wholesale grading of extensively disturbed deposits may be appropriate to detect the survival of features still intact below plow zones or highly disturbed site surfaces. The rationale for such use should be explained in the research design.

Records must be made of all testing in the normal detailed manner used in any archaeological excavations. At least one photograph should be made of each test pit, profiles drawn of at least one wall of each test pit (profile of at least two walls are recommended) and backhoe trench, soil

matrix described, artifacts described and analyzed by stratigraphic or arbitrary levels. Placement of test pits must be in relation to at least one permanent datum, so that the pit(s) can be relocated in the future. Scale, direction/north arrow, datum, and location of all tests, must be indicated on all maps and photographs. Date and recorder should be included where appropriate.

Data Analyses

As mentioned earlier, the project sponsor is responsible for ensuring that all data analyses are completed once any artifacts, other cultural materials, and other types of data are removed from the ground regardless of whether or not the eventual project is pursued. The consulting archaeologist is responsible for conducting appropriate analyses and interpreting the data that tell the story of the site. The anticipated data analyses described in the Research Design are the basic analytical tasks that will be conducted subsequent to the field investigation. The tasks set forth in the Research Design are specific to the types of sites that are being evaluated. However, once excavation begins, there may be changes in the data recovered and the expected analyses. The archaeological consultant should immediately inform the client if the unexpected type and/or volume of data categories discovered require additional or markedly different analyses. Sufficient charcoal may be found in a feature meriting a carbon 14 date during this phase of study. Obsidian may also be recovered enabling obsidian sourcing and hydration studies to be completed.

Public Education and Outreach

The Oregon SHPO expects archaeologists to consider public education and outreach efforts after Phase II investigations if the site is determined to be especially significant. Depending on the results of the study, scale of the project, character of the site, extent of interested publics, project sponsor, and other considerations, public education may also be appropriate during the field investigation.

Collections Care and Management

Phase II investigations are expected to collect more cultural materials, data, and records than Phase I. Accordingly, provisions should be made early on for the various decisions that must be made about collections care and disposition during investigations and analyses. See Appendix C for details on minimum curation standards for preparing collections.

PHASE III INVESTIGATION: DATA RECOVERY STUDY

The objectives for Phase I and II Investigations outline the core requirements for Phase III investigation. The Phase I and II investigations establish the foundation and framework for this last, most intensive, and intrusive level of archaeological study. The Oregon SHPO uses the Advisory Council on Historic Preservation's Recommended Approach for Consultation on Recovery of Significant Information from Archaeological Sites (see www.achp.gov/archguide.html) for guidance on data recovery investigations in both federal and state projects. The following are supplementary requirements for Phase III.

Goals for Phase III Investigation are:

- Recover the maximum amount of cultural, environmental, methodological and interpretive information and values from the site before the site is destroyed in whole or in part. Such data should represent all components of the site that will be affected.
- Meet the objectives of the Research Design.
- Provide a high level of public education and outreach to ensure that the proposed destruction of the site provides maximum benefits to a wide audience.

Research Design Requirements for Phase III

The Phase III Research Design should:

1. Meet the Research Design Standards.
2. Include the appropriate Phase I and Phase II Research Design requirements.
3. Provide a detailed discussion of the research topics and questions to be addressed.
4. Discuss the types of data that must be gathered in order to address these topics and questions.
5. Discuss strategies and methods for recovering the needed data.
6. Discuss methods of analyses and interpretation.
7. Identify interdisciplinary experts who may participate in the study.
8. Identify proposed methods of public outreach.

Depending on the nature and scale of the project and proposed archaeological results and methods, the SHPO may recommend peer review of the Research Design.

Data Recovery through Controlled Excavation

As previously discussed, data recovery usually entails controlled excavation of a predetermined sample of the site's contents. Depending on the type of site, research questions, and data classes expected, a number of strategies might be used including remote sensing to target subsurface features, block excavation, isolated units, and/or linear trenching. If necessary, heavy equipment such as a grader or front-end loader can be used to remove overburden. This is a very effective way of quickly removing sterile, disturbed, or non-significant fill, enabling labor-intensive hand excavation to be focused on those deposits that contain significant data. Whenever heavy equipment is used, archaeologists must be present to monitor the soil removal and record any artifacts or features that are exposed.

Although specific techniques may vary from site to site, all excavations should conform to the basic practices of data collection and recording. These include the use of standardized excavation units and a grid system, the use of natural or arbitrary levels to maintain vertical control (i.e., $\leq 10\text{cm}$ levels), the screening of excavated soil using a standard $\frac{1}{8}$ inch (3.2mm) mesh or alternative size appropriate to the artifact classes demonstrated to be within the site, the careful and standardized recording of provenience information including maps and stratigraphic profiles, and the maintenance of a complete photographic record of the excavation.

Screen Size: Screens should be used to recover specimens whenever possible during survey and excavation. Mesh no larger than ¼" (6.4 mm) should be used, and suitable smaller mesh and/or flotation should be used to recover appropriate environmental remains (e.g., fauna, macroflora). One-eighth inch (3.2mm) screen mesh is generally recommended for all subsurface testing within a known site's boundaries in order to gain a maximum amount of information from all site disturbances. This smaller mesh size should be used for all site testing until testing demonstrates it to not be necessary.

The use of larger mesh screening to recover remains must be fully justified in the archaeological permit (when known ahead of time) and final report (e.g., "removed entire feature with trowel and brush due to fragile nature of remains"; "soil too clayey to screen - troweled all shovel tests"). Changes in screen mesh size after an archaeological permit has been issued need to be coordinated with SHPO and added to the archaeological permit record. The sample recovery technique ("dry" screened or water-screened) must be noted. When samples are floated, the screen mesh sizes used to recover all fractions of materials must be noted.

Size of Excavation Units: The size of excavation units may vary although the most common sizes are 1 x 1 m, 1 x 2 m, 2 x 2 m and 3 x 3 m. The advantage of larger sized units is that the spatial arrangement of any post molds, fire pits, or other features that are exposed during excavation are easily seen in plan view which facilitates accurate mapping. The disadvantage is that spatial control is compromised for those artifacts that are recovered during screening. This can be overcome by subdividing larger units into smaller blocks (e.g., 1 m or .5 m squares) and excavating these separately. Individual excavation units larger than a 3 x 3 m square are discouraged because of the lack of spatial control in the collection of smaller artifacts. Larger block recovery may be appropriate where site disturbance is demonstrated to be more or less complete, or where the plow zone is being removed in search of features. The total sample size to be excavated needs to be incorporated in your proposed research design and representative of the portion of the site to be affected by the proposed project.

Depth of Excavation Units: Excavation will continue to a minimum depth of 50 cm and until at least two sterile levels have been encountered. At sites where Paleo-Indian or Early Archaic components are suspected, or where fill has been placed on top of native soils, deep coring or the use of backhoe tests to search for or expose deeply buried soil horizons may be required to ensure that these early and sometimes ephemeral sites are not missed.

Use of Natural Collection Units: An excavation takes place within natural units whenever possible. "Natural" means any unit of matter that displays abrupt and observable boundaries. Natural units may include soil stains, distinct strata, pits, mounds, or the rooms of a building. While most "natural" collection units will have had a cultural origin, this may not always be true. For example, windblown sediments, alluvial silts, or storm surges may have created discernible

strata that should be excavated as separate collection units. The use of natural units is specified to ensure that artifacts or other materials resulting from different depositional episodes do not become mixed during recovery.

When arbitrary excavation grid units are found to overlie a number of horizontally distinct natural units (sometimes referred to as features), excavation by natural units takes precedence. Thus, the material collected from a trash pit or storage pit is kept separate from the surrounding soil matrix in which the pit intrudes. Similarly, if the walls of a structure are encountered, materials from the outside of the structure are kept separate from those materials collected from the structure's interior.

The methods used to excavate cultural features depend on the type of feature encountered and the nature of the soil matrix. The preferred method is to pedestal the feature and then excavate half of it to expose a cross-section profile that can be mapped and photographed. The remaining half of the feature can then be excavated as a total sample. This is a particularly effective method when excavating in stable soils. In soft, sandy soils, feature fill may be removed as a total sample without pedastaling; however, no profiles are possible using this technique.

Standards for Public Education and Outreach

Public education and outreach should be considered an important component of all Phase III archaeological investigations. Too often the only record of significant archaeological projects is the creation of an access-restricted report that provides the public with no information on the importance of local land use history, changes in area lifeways, or how public monies are being spent. Historic preservation efforts should seek ways to reach the public in helping them to become aware of their local history. Items to consider include:

- Landowners, towns (both local government and community groups), educators, students, and the general public are likely targets for education and outreach.
- To the greatest extent possible, education and outreach projects and programs should be conducted in consultation with the local community and other interested parties both during planning and implementation. School field trips and community lectures should be considered.
- Education and outreach activities should be coordinated with Native Americans as appropriate.
- Exceptional sites or special projects may require enhanced education and outreach as a component of the Phase I investigation.
- Historic archaeological sites may be suited to different types of education and outreach efforts planning and implementation.
- Working with a local reporter can help to develop accurate and sensitive reporting that will publicize a project's results without jeopardizing its long term preservation.
- The creation of a project video that can be shared with the public through the Archaeology Channel or other venue.

In summary, public outreach in the form of site tours, videos, presentations or exhibits, or the production of reports appropriate for and informative for distribution to the public at libraries

and/or schools should be an integral component of the research design for Phase II and III undertakings.

MITIGATION

Mitigation of an adverse effect on an eligible archaeological site can be accomplished through one or more of the following actions: avoidance of impact, preservation or protection in place with legal covenants if possible, burial after testing if found to be appropriate, or data recovery. Agreement as to which mitigative action is appropriate is normally accomplished through a Memorandum of Agreement (MOA) or a Programmatic Agreement (PA), which includes a treatment plan. The first recommended mitigative option is avoidance of impact through redesign of the project. While avoidance is a perfectly legitimate tool to consider in Section 106 procedures, it must be understood that avoidance, in and by itself, is NOT a protective measure. That is, avoiding direct impact on an archaeological site may result in secondary or indirect impacts (for example, construction of playground facilities adjacent to precontact village site).

Protection or preservation is an active category of mitigation, something that is done to a site to protect it from any future adverse impact. Protection could involve development of the property for public interpretation, security measures limiting public access, local ordinances providing city or county protection with penalties, and so forth. Data recovery is another appropriate means of mitigation of adverse effect for archaeological properties. Through data recovery, the information contained in the site (or the portion of the site to be adversely effected by a proposed activity), which gives it its significance, is removed prior to project construction and the adverse effect on the eligible site is compensated for the excavation results. The site's significance (in the portion to be adversely affected) is no longer in the ground; it is in the records and collections being curated. When data recovery efforts are restricted to a portion of a significant site (e.g., remaining site portions are capped or avoided), the site remains significant after the mitigation has been completed.

Mitigation through data recovery must begin with the development of a detailed research plan, which discusses and justifies the design of the investigation to retrieve from the ground the information needed to answer research questions. The strategy of the fieldwork must be explained in detail, and the proposed analysis and expected results must be discussed.

As mentioned during Phase II and III investigations, if human remains are discovered or are part of a data recovery program, the procedures outlined in the Phase I discussion (:43) need to be followed.

For projects involving Section 106 review, the SHPO, the Federal agency, and the Advisory Council on Historic Preservation must approve the mitigation plan. In most cases, this plan becomes a part of a Memorandum of Agreement or Programmatic Agreement among these parties. Justification for the expenditure of public money on the data recovery project should be evident in the discussion of the expected results, and evidence of a signed agreement for curation of any recovered artifacts and records must be included in the plan. For non-Section 106 reviewed projects, Oregon SHPO will need to approve the mitigation plan with research design

and mitigation details included within the required state archaeological permit (see ORS 390.235).

Capping Sites with Fill

In certain circumstances, it may be appropriate to cap a site with fill to permit certain uses of the site area and/or to protect the entire site or surviving portions. The Oregon SHPO will not consider capping a site an adverse effect if the following two conditions are met:

- a. The cap material is potentially removable and does not forever bury the site. Some examples when capping may be considered (other examples may be appropriate) include:
 - Placement of geotextile cloth between surface and all applied fill;
 - 1' of fill over a site to construct a gravel access road or fire road;
 - 3' of fill over a site to permit bike path construction

Examples when capping of a site will not be considered a no adverse effect include:

- burying a site under a permanent, trafficked road such as a new highway.
- burying a site under a permanent building built on slab

In these examples, the site is possibly “forever” inaccessible for research and its characteristics may be disturbed in unknown ways from vibrations, weight, chemicals, etc.

- b. There have been sufficient site investigations to determine the feasibility of capping and to gather sufficient data to ensure an appropriate capping technique that will not adversely affect the site. This will require a Phase I investigation at the minimum and, depending on the circumstances, may require Phase II investigations as well.

Mitigation Alternatives

Mitigation is defined as actions that reduce or compensate for the impacts an undertaking may have on a NRHP listed or eligible site. The appropriate mitigation measure depends on a number of factors, including the applicable criteria for NRHP eligibility, as well as the nature of the effects of a proposed project or undertaking. Whenever possible, the best alternative is to preserve the site in place and to protect it from damage. Nondestructive **avoidance and minimization alternatives** should be considered as the first option. These measures may include:

- **Limiting the size** of a project or undertaking to reduce the effect on significant sites. Since many sites are relatively small in size, it may be possible to avoid a site by reducing the size of the proposed undertaking in the vicinity of the affected resource.
- **Modification** of the project or undertaking through redesign, reorientation or other similar actions. The redesign of a proposed highway to include a bifurcated median to avoid a burial mound, or the redesign of a residential subdivision to include more greenbelt areas would be examples of this type of mitigation alternative.
- **Repair, rehabilitation or restoration** of an affected property. Although typically associated with historic structures, this mitigation measure may be applicable in the case

of some historic sites that contain architectural features (e.g., iron smelter ruins, military fort, or defensive wall at a battlefield site). The restoration of vandalized or eroded surface features of a site may also be appropriate.

- **In-place preservation/protection** of deposits may be accomplished through several measures. For example, fill can be placed over buried sites and natural vegetation planted (with roots that will not extend below fill depth) to ensure stabilization. A conservation easement or restrictive covenant may be added to a deed; or a site may be donated to a preservation organization for conservation and preservation purposes. Also, the site can be designated as a greenbelt, nature preserve, or passive recreation area. Protection responsibilities are assigned to all federal and state land management agencies whose properties contain significant historic resources, as well as to those of federal, state and local agencies, and land developers whose activities are governed by the provisions of historic preservation law and might affect significant historic resources.
- **Restriction** of ground disturbance activities to depths shallower than the uppermost-undisturbed zone of significant sites. For example, parking lot development is one type of shallow or exposed construction activity that may occur without adversely affecting underlying deeply buried significant resources.
- **Monitoring** of ground disturbance activities to record significant remains if they are encountered. This is particularly useful if ground disturbance is expected to be minor or limited in spatial extent, where an upper disturbed layer can be affected without disturbance of a deeper intact deposit, and where conditions are such that hand excavation prior to the undertaking is feasible. For example, a highway-resurfacing project or development of a particular parcel of land located in the vicinity of a previously recorded site could be subject to monitoring and subsequent recording of exposed features and materials.
- **Off-Site Mitigation:** In the case of some projects or undertakings, it may not be feasible or appropriate to mitigate adverse project effects through any of the aforementioned measures. For example, suppose that the construction of a new telecommunications tower is determined to have an adverse visual effect to a NRHP-listed or eligible property or historic district. Given this, and similar circumstances, research and education options may be appropriate off-site mitigation measures. One of the following mitigation options may be appropriate in preserving the information about affected resources:
 - The preparation of a historic context for a particular category of historic resources (e.g., schools constructed by the Works Progress Administration [WPA]; drive-in movie theaters, Oregon prisoner of war camps, CCC camps in Oregon).
 - Prepare NRHP nominations for the affected properties.
 - Publish books, articles, technical assistance bulletins, land management plans, and local government comprehensive plans concerned with historic preservation issues, policies and procedures. This could include a written history of the community affected by the project or undertaking, in a format suitable for the public, such as a brochure, booklet or site on the World Wide Web.
 - Financially support a local museum or historical society or association engaged in local preservation activities.
 - Development of exhibits, videos, and web sites highlighting the historic resources and historic preservation programs of state and local governments. For example,

- this could include underwriting the preparation of a museum exhibit or traveling display
- The preparation of classroom lecture material concerned with Oregon's precontact and historic heritage, historic resources, and historic preservation issues.
 - Historic tours, public archaeology programs, market days, and celebrations in historic districts, and other activities drawing attention to the historic resources representing the precontact and historic heritage of the state and our communities.

One of the conditions often required for project approval when preservation in-place (rather than data recovery) occurs is the recording of deed restrictions/covenants or easements for the affected property. When such actions are initiated by the property owner, in addition to a lower property tax valuation (actually a tax deferral) for the restricted area, the restricted property may be conveyed to a conservation organization or governmental body. The difference between the pre-restricted value and the restricted value may be deductible from individual or corporate income taxes. Consultation with legal counsel is advised. Copies of such restrictions or easements must be provided to the SHPO to evidence compliance with preservation conditions of project approval. See Appendix B for a sample of "Preservation Deed Covenant."

If a site preservation area later is reconsidered for development, it is recommended that, as a condition of project approval, the requirement to mitigate project impacts is considered to have been deferred and not waived. For example, if a golf course were redesigned such that previously preserved site areas will be adversely affected, site mitigation would be required. This requirement should be stipulated in the original preservation easement. For this reason, the locations of preserved site areas generally are marked on site development maps to assure that their presence is not overlooked in any on-going grounds maintenance, landscaping, or development actions, and to facilitate protective monitoring efforts. Likewise, project approval documents may include penalty provisions (equal to or greater than the mitigation costs) for violations of preservation conditions.

ARTIFACT PROCESSING, DATA ANALYSES AND CURATION

While minimum standards for artifact processing, analyses, and curation are outlined below, investigators should tailor their activities to the unique aspects of each project. Overall, it is advisable to consult with SHPO, the curatorial facility, and any specialists early in the planning process.

Processing, analyzing, and curating artifacts must occur in secure and safe environments to prevent loss of significant data. The Principal Investigator and Project Archaeologist are ultimately responsible for ensuring that artifact data and integrity are preserved. The laboratory staff responsible for basic artifact processing and analysis must have sufficient knowledge to do the work, have access to appropriate comparative collections, and have access to experts when needed. Additionally, laboratory staff and/or the Project Archaeologist should have training in basic curatorial procedures.

Field Tracking

The choice of a system for tracking artifacts in the field is at the discretion of the investigator. However, the tracking system should be consistently applied throughout the project. During fieldwork, the recorder will enter a preliminary description of the artifacts in field notes and forms before placing them in labeled containers that fully protect them from damage. Artifacts can then be brought back to the laboratory for cleaning and analysis.

Processing

Before cleaning each artifact, the recorder will check its condition (e.g., for friability) and analyze its surface for easily lost information (e.g., pseudomorphs, organic materials, pigments, etc.). Artifacts should then be cleaned in a manner that preserves the information they contain. For information on proper artifact cleaning techniques refer to the Society of Historic Archaeology's (SHA) web page (http://www.sha.org/research_resources/conservation_faqs/process.cfm#). After they are clean, all diagnostic artifacts will be labeled to record site number, provenience, and catalog number. Care should be taken to ensure that important features like edge wear are not obscured during labeling.

Be sure and check with the curation facility where the artifacts will be curated (in Oregon this is usually the University of Oregon Museum of Natural and Cultural History) for any specific guidelines that need to be followed. In general, numbers written on artifacts are to be sealed with an appropriate sealant such as 10–15 percent solution of Acryloid B-72 in acetone or toluene. A small labeling area should be chosen, and an undercoat of the Acryloid B-72 placed on only this area of the artifact. The artifact will then be labeled on this area using black or white India ink. After allowing sufficient time for drying, an additional coat of the sealant is to be applied over the label. As an alternative to the white ink, white Acryloid B-72 is available commercially and may be substituted for the undercoat (a clear overcoat is still needed). Clear fingernail polish as a sealant is not acceptable.

All artifacts will be bagged individually or by type in self-sealing polyethylene bags at least 4 millimeters (mm) thick. Those available as food storage bags are not acceptable as they are often not polyethylene. A descriptive tag should be enclosed in each individual/type artifact bag. This tag should give provenience, description, and count for the contents. Artifacts must not be bagged until completely dried. Artifacts may be bagged by provenience or type (i.e., ceramics, lithics, etc., from all proveniences stored together, or all types of artifacts bagged by excavation provenience) based on the analysis needed. Diagnostic artifacts should not be bagged loose together with other materials that may damage or obscure edge wear or other important features. However, the laboratory methods section of the report will detail this information. The researcher should strive to curate all artifacts in a manner that will allow future researchers to duplicate their methods.

Identification tags for boxes or bags will be prepared. Tags will be made of an inert, waterproof, archivally sound material (e.g., Nalgene, Tyvek, polyweave, etc., or an acid-free paper tag inserted into an appropriately sized polyethylene self-sealing bag) and marked with ink that is

fade-proof, waterproof, and archivally stable. The bags containing the artifacts will be labeled as well. All information on the exterior of the bag will be repeated on an internal tag of the type described above.

Laboratory staff should be aware of curation policies of the various repositories. Additionally, all artifacts should be handled to the standards of the University of Oregon Museum of Natural and Cultural History, SHA/SSA/AIA and 36 CFR Part 79.

Analysis

If detailed analysis of certain archaeological materials is planned, it is advisable to include appropriate specialists, and budget for them, as early in the project as possible.

Because most archaeological sites are valuable primarily because of their research potential, artifact analysis generally should follow well-established classification schemes and typologies. The choice of a specific system will depend on the investigator's goals and should be fully defined and referenced in the project report. Regardless of which classification system one uses, certain basic descriptions and analyses must be included in the report:

- Artifact identification number or provenience.
- Material (e.g., lithic, ceramic, glass).
- Class (e.g., projectile point, sherd, bead).
- Count and/or weight, as appropriate.
- Dimensions, if appropriate.
- Type (e.g., Clovis, Creamware, etc.).
- Noteworthy attributes (e.g., form, decoration, method of use, internal or external dating).

A laboratory or catalog sheet printed on archival paper with archivally stable, waterproof ink should be used to record the analyst's observations. In addition, the analyst may keep a diary of any observations, impressions, drawings, and any special analyses performed on the artifacts. This will become part of the official record when the collection is curated.

Conservation and Curation

Curatorial facilities should meet the standards outlined in 36 CFR Part 79; for Federal or federally assisted undertakings this requirement is mandatory. Selection of a facility is best made during development of the Research Design and MOA, since curatorial standards specific to the facility may influence conservation work during lab preparation and analysis. The designated curation facility should be identified in the project report. In Oregon, the primary curation facility for all artifact collections resulting from excavations conducted under a state archaeological permit is the University of Oregon Museum of Natural and Cultural History (UOMNCH). Be sure to consult with the selected curation facility prior to beginning conservation activities. All pertinent field, laboratory, and report documentation should be archivally prepared and remitted to the curation facility with the artifacts. For projects where no artifacts were recovered, notes and other project materials should be prepared for curation. This should include any photographic material and electronic media including any artifact databases.

If these databases are coded, a copy of the coding system should be supplied to the curation facility. See Appendix C for a more complete discussion of curation requirements.

If artifacts are recovered from private land in Oregon under a state archaeological permit, the landowners have the right to keep the artifacts or donate them to a museum of their choice for long term curation and study. While Oregon SHPO encourages all land owners to donate any artifact collections to a recognized museum for the maximum benefit to the public, if the landowner chooses to have the artifacts returned to them the above analysis and curation standards still need to be followed. Upon completion of the artifact conservation process and the final project report, a copy of the final report should be sent to the SHPO, Legislative Commission on Indian Services (CIS), UOMNCH, and all appropriate Tribes for review. Appropriate tribes should be given up to 30 days to review the final report to see if any sacred objects or objects of cultural patrimony are contained within the resultant artifact collection. Artifacts should be returned to the landowner only after this review period has been completed. If a tribe notifies the archaeologist of the presence of a sacred object or object of cultural patrimony that they are requesting be returned to the tribe, such objects should not be returned to the landowner until proper ownership of these items can be confirmed. Be sure to send a copy of the tribal repatriation request form to SHPO (see Appendix D) so that it can be forwarded to UOMNCH for approval. If artifacts are to be returned to the landowner, a complete collection of the field notes, artifact catalog and site/artifact photos should be deposited at the Museum of Natural and Cultural History along with a copy of the final report.

SUMMARY

The sequence of work in consideration of cultural resources to be affected by federal/state projects should be efficient, economical, and justifiable. Briefly, the sequence is normally this:

- Locate and record basic information on all historic properties that are 50/75 years old or older in a project area.
- Test archaeological sites to see what is below the surface.
- Decide which sites are potentially National Register eligible and have the potential for providing significant information concerning precontact and historic lifeways and cultural processes. Provide adequate support for these determinations, including use of documentary research for historic archaeological sites.
- Arrange for appropriate curation of all artifacts and documents.
- Test those sites to establish their significance and, thereby, their eligibility for inclusion in the National Register. Documentary research is required for historic sites.
- Recommend the appropriate treatment for sites determined eligible for inclusion in the National Register. Oregon SHPO supports avoidance efforts for all eligible sites. If a site can not be avoided, an effort should be made to minimize impacts and mitigate any areas that can not be avoided.
- Mitigation in some form is required in all cases for sites in which human remains are expected or encountered, without exception (see (1): Advisory Council on Historic Preservation Policy Interpretation Memorandum 89-1, Treatment of Human Remains and Grave Goods; (2): PL 101-601, Native American Grave Protection and Repatriation Act; and (3): ORS 97.740-760, Indian Graves and Protected Objects.]

- Carry out mitigation measures.
- Publish results and consider sharing appropriate project information through a public education format.

BIBLIOGRAPHY

Andus, Patrick W. (finalized)

1997 How to Apply the National Register Criteria for Evaluation. *National Park Service Bulletin # 15*. USDI, National Park Service. Edited by Rebecca H. Shrimpton. Written by staff of the NRHP. (originally published 1990).

Bense, Judith A., Hester A. Davis, Lorraine Heartfield, and Kathleen Deagan

1986 Standards and Guidelines for Quality Control in Resource Management in the Southeastern United States. *Southeastern Archaeology* 5(1):56-62.

Dierker, J. L., and L. M. Leap

2005 Archaeological site monitoring and management activities along the Colorado River in Grand Canyon National Park. Report submitted to the U.S. Bureau of Reclamation, Salt Lake City, UT. *RCMP Report* No. 90, Flagstaff, AZ.

National Park Service

1997 How to Complete the National register Registration Form. *National Register Bulletin # 16A*. USDI, National Park Service.

O'Donnell, Eleanor

1998 Researching a Historic Property. *National Park Service Bulletin # 39*. USDI, National Park Service (originally published 1991).

Omaha District

2005 Cultural site monitoring and enforcement plan (draft, April 2005). U.S. Army Corps of Engineers, Omaha District.

Parker, Patricia L., and Thomas F. King

1990 Guidelines for Evaluating and Documenting Traditional Cultural Properties. *National Register Bulletin # 38*. USDI, National Park Service.

Shaffer, Gary D., and Elizabeth J. Cole

1994 Standards and Guidelines for Archaeological Investigations in Maryland. *Maryland Historical Trust Technical Report* Number 2. Office of Archaeology and Office of Preservation Services, Maryland Historical Trust.

Walton, T.

2003 Methods for monitoring the condition of historic places. *Department of Conservation Technical Series 27*, Wellington, New Zealand.

APPENDICES

APPENDIX A: ESTABLISHING SITE SIGNIFICANCE

ESTABLISHING SITE SIGNIFICANCE

Assessing site significance is often a cumulative process in which more and more data are collected to reach the point where the importance or significance of the site can be established. Although that point can sometimes only be reached after Phase II investigations, at other times significance can be established sooner. This section of the Guidelines provides guidance in how to assess site significance and how to assess it as early in the review process soon as possible. Thus, sites that are not likely to yield important information are eliminated from consideration early.

Oregon SHPO believes that all sites should be treated as eligible to the National Register of Historic Places (NRHP) until proven otherwise. That is not to say that all sites are eligible to the NRHP, only that they needed to be treated as such until sufficient information can be collected to determine their eligibility. In this way a site will not be inadvertently destroyed simply because an agency did not invest the time to collect the information needed to make such a determination. If a decision of a site's eligibility to NRHP (i.e., significance) is required and documentation about the site's attributes is inadequate, the site must be treated as if it was eligible so that federal regulation will provide it protection until the site's eligibility can be determined.

Archaeological investigations conducted under federal and regulatory requirements seek to identify "significant" archaeological sites. A significant site meets the criteria for inclusion in the State or National Registers of Historic Places. Both registers use the National Register criteria for evaluating significance. The National Register criteria are:

- Criteria A:** Sites that are associated with events that have made a significant contribution to the broad patterns of our history.
- Criteria B:** Sites that are associated with the lives of persons significant in our past.
- Criteria C:** Sites that embody the distinctive characteristics of a type, period, or method of construction, or that represent the work of a master, or that possess high artistic values, or that represent a significant and distinguishable entity whose components may lack individual distinction.
- Criterion D:** Sites that have yielded, or may be likely to yield, information important in prehistory or history. National Park Service Bulletin #15 *How to Apply the National Register Criteria for Evaluation* (Andrus 1997:21) sets out two requirements for Criterion D of the National Register that are especially relevant to the Guidelines:
 1. The site must have, or have had, information to contribute to our understanding of human history or prehistory, and
 2. The information must be considered important.

Sites may also be eligible to the National Register for the associative value a site may hold for descendant communities. Such sites are generally referred to as Traditional Cultural Properties (TCP) and may be considered eligible due to their association with cultural practices or beliefs of a living community that (a) are rooted in the community history, and (b) are important in maintaining the cultural identity of a community (Parker and King 1990:1). See National

Register Bulletin # 38 *Guidelines for Evaluating and Documenting Traditional Cultural Properties* for more details on this property type.

The most important thing to remember about significance in terms of the NRHP is that it is a relative term. Significance must be evaluated within a relevant context. Is it more or less significant than some other object, site, building, or structure? Does this make any difference as far as federal laws and regulations are concerned? The answer to these questions is no. If a “degree” or “level” of significance to the NRHP is determined by the lead federal agency, and SHPO concurs with this determination, or if a determination is obtained from the Secretary of the Interior pursuant to applicable National Park Service regulations, then the Federal agency must assess effects, per 36CFR800.4(c)(2).

The National Register criteria must be used in establishing the significance and eligibility of any property for nomination to the National Register (see Andrus 1997). Criterion D, that the property has contributed or may be likely to contribute to information important to history or prehistory, is the most common criteria used for establishing eligibility of archaeological sites; however, other criteria may also be applicable. To establish that an archaeological site may indeed contribute information about history or prehistory, four attributes should be considered: structure, content, integrity, and quality (or resolution).

Site Structure refers to the overall vertical and horizontal configuration of the artifact-bearing sediments along with cultural features found within and upon those sediments (such as houses, barns, living surfaces, post mold patterns, pits, hearths, and/or noteworthy concentrations of artifacts). Within the natural strata of a site it may be possible to identify discrete cultural strata, which may be defined as sediments deposited by or substantially altered as a consequence of past human activity.

Site Content may be defined as the assemblage of natural and cultural materials contained within archaeological sediments. Natural materials could include naturally occurring pollen, plant remains, or animal remains reflecting past environmental conditions. Cultural materials such as stone or bone tools and manufacturing debris, pottery, fire-cracked rock, and preserved plant and animal food remains, indicate the kind of human activities that once took place at the site. Natural and cultural materials found in archaeological sediments may be analyzed and interpreted to provide inferences concerning past lifeways and environments. It is important to recognize, however, that a variety of natural and cultural processes may affect the preservation of materials, thus altering the structure and content of the site. In extreme cases, such alterations may effectively erase most or all traces of past human activity.

Site Integrity refers to the present physical condition of the site. In order to be listed in the NRHP, a cultural resource must meet Criteria A, B, C, or D **and** must possess **integrity**. According to the Guidelines for *How to Apply the National Register Criteria for Evaluation* contained in [NRHP Bulletin 15](#), integrity is "the authenticity of a property's historic identity, evidenced by the survival of physical characteristics that existed during the property's historic or prehistoric period" (Andrus 1997). The NRHP criteria specify that integrity is a quality that applies to historic and prehistoric resources in seven ways: **location, design, setting, materials,**

workmanship, feeling, and association. These aspects, or qualities, of integrity, are defined below.

- **Location:** The place where the historic property was constructed or the place where the historic event occurred. The relationship between the property and its location. Has the property been moved, or has the location been altered significantly?
- **Design:** The combination of elements that create the form, plan, space, structure, and style of a property.
- **Setting:** The physical environment of a historic property.
- **Materials:** The physical elements that were combined or deposited during a particular period of time and in a particular pattern or configuration to form a historic property.
- **Workmanship:** The physical evidence of the crafts of a particular culture or people during any given period in history or prehistory.
- **Feeling:** A property's expression of the aesthetic or historic sense of a particular period of time.
- **Association:** The direct link between an important historic event or person and a historic property.

Analysis of integrity should be based on careful research in terms of both documentation of the property's history, and physical inspection of the property. For properties important for their information potential, such as most archaeological sites, integrity depends on the presence of those parts of the property which contain the important data and which survive in a condition capable of yielding important information. Comparative information about similar sites that have survived should be considered during the evaluation of integrity. For example, a partially disturbed precontact site, which nevertheless retains some information on the form and function of bone tools, may be eligible if it can be shown that the information contained in that site is important because bone preservation is almost unknown in the region.

Site Quality or resolution refers to how observable or recognizable the condition is using contemporary archaeological field methods. Assessment of site condition and quality is based upon a careful analysis of the potential impacts of a host of processes affecting natural and cultural materials. As these materials cease to be a part of a living human ecosystem they become incorporated into an archaeological context. These attributes, common to all archaeological sites, can provide a basis for evaluating significance of a specific archaeological site. In making this assessment, the present condition of the site must be such that its content, along with the context of those materials within the overall structure of the site, will permit interpretations to be made concerning past human activities and cultural processes. The likelihood must exist that any such interpretations will add substantially to the present understanding of one or more of a series of research problems (mentioned elsewhere in the archaeological literature) dealing with past human activities and cultural processes at the local, state, regional, or national level.

In order for a site to be determined not significant, it must be demonstrated through adequate documentation from fieldwork and from historic sites archives that the site cannot provide this information. When completing site and nomination forms, the National Register criteria under which a determination of eligibility has been made must be indicated.

Although precontact archaeological sites may be eligible for inclusion in the National Register under Criteria A, B, and C, their significance is most often established under Criterion D. Extensive site investigations in Oregon lead us to conclude that a precontact site will meet Criterion D if it has the following characteristics:

- a. The site has integrity; and
- b. The site contains multiple categories of data; and
- c. The site can help answer specific, detailed questions that are important to understanding Oregon precontact or contact period and can be justified as having value to the public.

Category (a) has been addressed above. The following section addresses expected site characteristics related to (b) and (c) above.

Determining Significance under Criteria D

A site must contain, or be likely to contain, sufficient categories of data to address important research questions. To address a particular Research Topic, sites must at minimum contain the types of data shown in the Data Requirements columns of Table 1.

Research Topics	Data Requirements (see details below)							
	1	2	3	4	5	6	7	8
Adaptation	X	X	X	-	-	X	-	X
Chronology	X	X	X	-	-	-	-	-
Technology	X	X	-	-	-	-	-	-
Exchange/trade	X	X	-	-	X	-	-	-
Settlement system	X	X	X	X	X	-	-	X
Subsistence system	X	X	X	X	-	X	-	-
Socio-political organization	X	X	X	X	-	-	-	-
Human biology	X	X	X	-	-	X	-	-
Belief system	X	X	X	-	-	-	X	-
Environmental change	-	X	-	-	-	-	-	X

Table 1: Assessment of Significant Data Needed for Determining Significance

Data requirements for a site to address the respective research topics:

- 1. Site contains items, deposits, and/or surfaces that can provide inferences about past activities.
- 2. Site contains items or deposits that can identify the site’s time period.
- 3. Site possesses spatial relationships among items, deposits and/or surfaces which can be reconstructed.
- 4. Site contains deposits with floral, pollen, faunal or other botanical and zoological data.

5. Site contains items whose potential source area(s) can be identified.
6. Site contains the remains of at least one inhumation sufficiently preserved to permit analysis of diet, health, pathologies, or demographic data; or contains evidence of at least one cremation.
7. Site contains non-utilitarian items or deposits that can provide inferences about past beliefs.
8. Site contains natural or cultural deposits or surfaces with data pertinent to paleoenvironmental reconstruction (including past vegetation, fauna, landscape, water sources, or climate) of the locale or larger region.

Ability to Answer Questions Important to Understanding Oregon's Past

Research questions regarding Oregon's prehistoric cultural heritage provide a baseline for examining a precontact site's potential significance. The research questions are organized by research topic listed in Table 1. To answer these research questions, at a minimum, sites must contain certain categories of data and characteristics. Evaluations of site significance must be as specific as possible in relating a research question to available or presumed site data. Significant sites contain categories of data that have a high likelihood of providing important information that will respond to one or more of these questions.

Adaptation:

- How did changes in climate affect native people over time (e.g., seasonal adaptations)?
- What evidence exists to substantiate changes in lifeways and technologies in Oregon over time? What caused changes? How long did changes take? How did changes in one aspect of life affect other aspects of life? Did different parts of Oregon see different changes? Where and why?
- How and when did contact with Europeans affect the local population? Direct/Indirect?
- Can affects from local or regional conflict or disease be found? Intertribal? Euro-American interaction?

Chronology:

- When was a particular site occupied and how does its occupation relate to other sites in the area?
- Does a site contain multiple periods of occupation?
- Are there artifacts that can be used to relate a site's land use activities through time (e.g., projectile point typology, changes in fishing technology, pictograph/petroglyph design motifs)?

Technology:

- Are changes in technology evident in a site's artifact assemblage? If so, how do these changes relate to seasonal use of the site, reuse over multiple years, activity focus or people utilizing the site?

Exchange/Trade:

- How does material culture shed light on precontact exchange systems within and outside the region?

- Are artifacts present that can be used to substantiate the influence and connection between cultural groups (e.g., slavery, intermarriage, social networking)?

Settlement System (including Human Populations):

- How many people lived in Oregon during the precontact period? 5000? 14,000?
- How did settlement patterns in Oregon change over time and in what way did these patterns differ between regions (e.g., Coast, Cascade Mountains, Great Basin, and Columbia River)?
- How are sites distributed across the landscape?

Subsistence System:

- How did subsistence activities change across the Oregon landscape through time? What was the role of fishing with regards to primary subsistence focus and what effect on local lifeways did changes in intensification have?
- What subsistence resources are available in an area now? Compared to what would have been available in the past?

Socio-political Organization:

- What evidence exists of social-political organization and how did this change over time? Evidence of slavery? Evidence of different, and separate, Native American cultural communities within close proximity to each other?
- Evidence of social stratification within a site? Differences in harvest, use or access of particular resources?
- Oral history/place name information available on site/area that could add knowledge of people using site/resources?
- Was there ethnic continuity in Oregon's Native people in an area over the entire pre-contact period? If yes, were there breaks/gaps in that continuity? If no, what ethnic differences, changes existed?

Belief System:

- What types of locales were preferred by Native American people for burial sites? Why did burial practices change over time? How can we better predict, and thus better protect, the locations of Native American cemeteries and burial sites from different periods of history?
- What forms of rock images (i.e., pictographs, petroglyphs) are found within a given area? What is the tribal and/or ethnographic history of such locales? Interpretations for given images? How did such sites change over time (e.g., design motifs, use of color, interpretive role to local native peoples)?
- How were rock cairns incorporated into the local belief system? What variety of cairn types are present in an area and does cairn formation vary based on intended use (e.g., rock on rock vs. stacked rock pile)? Are cairns still being used and/or constructed for current religious observance? If so, has the type of cairns built, preferred construction area or incorporation of such cairns changed over time?

Environmental Change:

- Did environment change during the period of site occupation being studied and if so,

how did use of a particular site change? How are these changes revealed in the archaeological record?

- What evidence exists to substantiate Oregon's earliest inhabitants co-existing with extinct mammals?
- How did Oregon's environments and climate change through time and how did native people adapt to these changing conditions?
- What was the distribution of native flora and fauna (including native fish species) over time?

Establishing Historic Period Site Significance

In Oregon, the "historic period" is generally considered to begin in 1805, with the arrival of Lewis and Clark to the Pacific Northwest. While it is true that limited contact from ships are known to have occurred along the coast prior to 1805, this contact was of short duration, with no written records of its extent or effect other than a few European items being found in precontact sites and the effects of introduced diseases. Historic period archaeological sites, even those with good integrity, do not automatically have historic significance. The Oregon SHPO supports archaeological significance of historic period archaeological sites during the regulatory process if they have a very high likelihood of providing important information. Such information is usually available from ethnographic and ethnohistoric documents and photographs, and oral history interviews, however, the historic record of what occurred at an archaeological historic site can only be confirmed by testing of that site.

In contrast to precontact sites that can only be discovered and studied through archaeological investigation, many kinds of historic period sites can be understood through historic maps, photos, drawings, written records and, sometimes, oral histories. For these kinds of historic sites, it is critical to ask at the earliest time possible whether they might have archaeological significance and how archaeological methods at that site can significantly and measurably improve our understanding of Oregon's past. The question of "importance" of historic period sites needs to be addressed carefully with consideration given toward whom the importance is held. If the site is important to just one historical archaeologist or to just a few members of a community, its significance will be difficult to justify. An exception to such limited significance would be those sites that represent traditional cultural properties (e.g., local meeting hall, church or other feature) and are considered essential to the continuity of a small community of people.

Some types of historic period sites do not have the potential to provide information important to a broad public. Some sites, (e.g., many types of mills-flour, logging, salmon processing), may be well documented in written and other records and many exist as standing structures; archaeological investigations may not provide useful or outstanding complementary information. In such a case, historic research may be far more informative than an archaeological investigation.

The Oregon SHPO supports several policies regarding historic period archaeological sites. A site shall be studied archaeologically in the regulatory process if:

1. It addresses or is likely to address in a significant way the priority research topics listed in these Guidelines.

2. It has the potential to add important information to or verifying the written and archival record.

Defining a “Site” in the Context of Historic Period Archaeology

Historic archaeological sites in Oregon that are located on non-federal public or private land generally date from 1805 – 1930. On federal lands historic sites generally need to be at least 50 years of age. For purposes of these guidelines, a “site” must involve an assemblage or cluster of data sets that usually includes foundations, ruins, or some type of structural remains, features, deposits, and other man-made alterations to the landscape that can be investigated using a combination of historic research and archaeological investigations to varying degrees. Some kinds of important sites were temporary occupations or encompassed traditions or activities that did not produce foundations, ruins, or other structural remains. In such cases, features and deposits are the core site components.

Research Topics to Help Evaluate Significance of Historic Period Sites

In the context of historic archaeology, there are as many research topics and questions as there are scholars asking them. They need to be pared down to what’s most important to a broad public. The following research topics were identified by the SHPO as priorities since they may only be addressed through archeological study. If a potential or identified historic period site can address these topics and related, important research questions, the site will be further considered by Oregon SHPO and may be recommended for further investigation through the regulatory process. Furthermore, archeological sites relating to a detailed historic context that meet the property type’s registration requirements may be considered significant by the SHPO even though they are not associated with the priority topics below. For a discussion on historic contexts, see NPS Bulletin #16A *Guidelines for Completing National Register of Historic Places Registration Forms*.

The research topics listed below are general. They are intended to be used as a guide to assist in determining site significance and not all inclusive. The Oregon SHPO may still consider compelling sites that don’t fall into these categories if they demonstrate the likelihood of providing important information to a community or to the state.

Examples of priority research topics important to Oregon history that may be addressed through archaeology at individual sites include:

- Native people and their communities after European contact
- Reservations, missions and schools associated with Native American resettlement efforts
- 19th century military history
- Hudson Bay trade related sites
- Abandoned communities (Oregon’s “ghost towns”)
- 19th century French settlement in Oregon
- Early Euro-American settlement including farmstead economy and technology, mining, logging, grazing, industry and commerce, health and nutrition, and transportation
- Pre-1900 industries and commercial enterprises

- Unanswered questions about Oregon’s ethnic and minority groups
- Oregon’s maritime history
- Unwritten stories of important Oregonians (pre-1900)
- Unique, rare, highly unusual, and exceptional federal, state, and local public works
- Unique, rare, highly unusual, and exceptional sites

Identifying Important Research Questions and Necessary Data Sets

The consulting archaeologist must first identify specific, important research questions that can be addressed at the site through archaeology that have not already been answered by historic documents or that are not likely to be answered by the historic record. Second, it’s necessary to identify specific data sets that must be present at, as well as recoverable from, the site to answer the research questions.

Quality of Site Evidence

Archaeology is ultimately about site discovery; hence, the expression “seek and ye shall find” applies strongly to our discipline. However, regulatory archaeology requires a greater degree of focus in this quest to ensure that public and private funds are spent with the reasonable chance of discovering and researching sites that are important to the state and to individual communities.

Accordingly, the quality of the evidence about a site’s existence in a particular location is an important consideration for the Oregon SHPO in determining whether or not to proceed with assessing an archaeological site.

Some examples of strong evidence for the existence of a site(s) in a given location include:

- 1) A recorded site.
- 2) Specific documentary reference to a site in that location from historic research.
- 3) Specific reference to a site in that location from knowledgeable local individuals.
- 4) Visible ruins and features on the ground surface.
- 5) Geographic or historic context that suggests the existence of a site or particular category of site
- 6) The standing structure itself is listed on or eligible for the National Register and is associated with a priority research topic; it may have archaeological components that contribute important archaeological information.

Summary of Information SHPO Needs to Determine if Site Assessment Process Should Continue

As early as possible in the archaeological assessment process (Phase I), the consulting archaeologist should determine and demonstrate to the SHPO that:

- 1) The site has the potential of addressing one or more of the priority topics.
- 1) There is strong evidence for the site’s existence in that location.
- 2) The site has the potential to answer -- through excavation – specific, important research questions.
- 3) The research questions being asked are of interest to a broad audience.
- 5) The site is likely to contain specific and recoverable categories of data that answer

- the research questions.
- 6) The site exhibits integrity or the likelihood of integrity.

POTENTIAL SIGNIFICANCE OF ISOLATED FINDS

Oregon State law (ORS 358.905(1)(a)) highlights the potential for archaeological objects (i.e., isolated finds) to yield significant information regarding past human life or activities. It is important that all isolated finds be evaluated for such potential. The discovery of, for example, 5+ artifacts or multiple artifact types (e.g., groundstone, flaked stone) in an area should normally trigger the need to excavate subsurface probes around the initial area of discovery to determine if the isolate is indeed an isolate locale rather than an archaeological site. Such probes would also provide a better understanding of the role such artifacts had in earlier lifeways based on cultural and landform data.

DETERMINING THE AMOUNT OF IMPACT ON A SIGNIFICANT SITE

Some projects that require a cultural resources survey and determinations of significance occur in long, linear areas. Often sites may lie both inside and outside a right-of-way or project corridor where some portion of the site will be impacted and some will not. It is important that archaeologists and agencies understand the scientific and practical requirements of such a situation.

Consideration of significance must take into account the whole site, no matter what portion of it may be within the area of direct effect. It is imperative that significance be established on the basis of the nature of the whole site and its potential; decisions of mitigation are then made on the basis of the potential of that portion of the site that will be impacted to add information of importance to research questions. The problem that can occur when this sequence is not followed can be explained by example.

Archaeologists were conducting a cultural resource survey of a long linear federal project. They restricted themselves to looking only within the right-of-way. A site was discovered, testing was done, undisturbed subsurface deposits were discovered which indicated potential for answering particular research questions, and significance was established. The report on this survey mentioned that other cultural material was noted to the west of the recorded site, outside the right-of-way, but no testing was done, and no determination of the size or nature of the site outside the right-of-way was made. A revisit to the site determined that this was a large site with excellent content and quality of information, the majority of which was outside the right-of-way. The nature of the whole site was defined and its significance established in relation to its research potential. On this basis, it was possible to determine that the portion of the site in the right-of-way was so small that the impact of the project would not be adverse relative to the whole site, and therefore little to no mitigation of that impacted portion was required.

In this case, failure to determine the nature of the whole site during the initial survey caused much more expense than would otherwise have been required. In cases where access to an entire site is not possible (e.g., landowner permission denied, outside ROW and funding agency will not permit expansion), the site will be treated as significant and mitigation measures will be evaluated accordingly.

The United States Department of the Interior's National Register Program has published several Bulletins as tools to help guide archaeologists, agencies, managers, and others in evaluating archaeological site significance. These include:

- *How to Apply the National Register Criteria for Evaluation* (NPS Bulletin #15)
- *Guidelines for Evaluating and Registering Archaeological Properties (2000)* (NPS Bulletin #36)
- *Guidelines for Identifying, Evaluating and Registering Historic Mining Sites (1992)* (NPS Bulletin #42)
- *Nominating Historic Vessels and Shipwrecks to the National Register of Historic Places (1992)* (NPS Bulletin #20)
- *Guidelines for Evaluating and Documenting Traditional Cultural Properties (rev. 1998)* (NPS Bulletin #38)
- *Guidelines for Evaluating and Registering Cemeteries and Burial Places* (NPS Bulletin #41)

These Bulletins and others can be downloaded from the National Park Service web site at

<http://www.cr.nps.gov/NR/publications/> .

APPENDIX B: PRERSERVATION DEED COVENANT (SAMPLE)

Preservation Deed Covenant

In consideration of the conveyance of certain **[improved]** real property, hereinafter referred to as **[name of property]**, located in the **[City of _____]**, County of _____, State of _____, which is more fully described as:

[insert legal description]

[Name of property recipient] hereby covenants on behalf of **[himself, herself, itself]**, **[his, her, its]** heirs, successors, and assigns at all times to **[specify: Federal agency transferring the property, or SHPO, or other]** to maintain and preserve **[name all those exterior and interior features that qualify the property for inclusion in the National Register; these may be named within the body of the paragraph or included as an attachment]** as follows:

1. **[Name of recipient]** shall preserve and maintain **[name of property]** in accordance with the recommended approaches in the Secretary of the Interior's *Standards for Rehabilitation and Guidelines for Rehabilitating Historic Buildings* (National Park Service, 1983) **[or specify other relevant standard, management plan, archaeological treatment plan, etc., with full citation]** in order to preserve and enhance those qualities that make **[name of property]** eligible for inclusion in the National Register of Historic Places.
2. No **[construction, alteration, remodeling/disturbance of the ground surface]** or any other thing shall be undertaken or permitted to be undertaken on **[name of property]** which would affect the **[structural]** integrity or the **[appearance/cultural use/archaeological value]** of **[name of property]** without the express prior written permission of **[Federal agency transferring the property, or SHPO, or other]** signed by a fully authorized representative thereof.
3. The **[Federal agency transferring the property, or SHPO, or other]** shall be permitted at all reasonable times to inspect **[name of property]** in order to ascertain if the above conditions are being observed.
4. In the event of a violation of this covenant, and in addition to any remedy now or hereafter provided by law, **[Federal agency transferring the property, or SHPO, or other]** may, following reasonable notice to **[name of recipient]**, institute suit to enjoin said violation or to require the restoration of **[name of property]**. The successful party shall be entitled to recover all costs or expenses incurred in connection with such a suit, including all court costs and attorney's fees.
5. **[Name of recipient]** agrees that **[Federal agency transferring the property, or SHPO, or other]** may at its discretion, without prior notice to **[name of recipient]**, convey and assign all or part of its rights and responsibilities contained herein to a third party.
6. This covenant is binding on **[name of recipient]**, **[his/her/its]** heirs, successors, and assigns **[in perpetuity/for X years from the date of this instrument]**. Restrictions, stipulations, and covenants contained herein shall be inserted by **[name of recipient]** verbatim or by express

reference in any deed or other legal instrument by which **[he/she/it]** divests **[himself/herself/itself]** of either the fee simple title or any other lesser estate in **[name of property]** or any part thereof.

7. The failure of **[Federal agency transferring the property, or SHPO, or other]** to exercise any right or remedy granted under this instrument shall not have the effect of waiving or limiting the exercise of any other right or remedy or the use of such right or remedy at any other time.

The covenant shall be a binding servitude upon **[name of property]** and shall be deemed to run with the land. Execution of this covenant shall constitute conclusive evidence that **[name of recipient]** agrees to be bound by the foregoing conditions and restrictions and to perform to obligations herein set forth.

**APPENDIX C: CURATIONS STANDARDS AND GUIDELINES FOR
ARCHEOLOGICAL INVESTIGATIONS IN OREGON**

UNIVERSITY OF OREGON MUSEUM OF NATURAL AND CULTURAL HISTORY
AND STATE MUSEUM OF ANTHROPOLOGY

GENERAL STANDARDS FOR ARTIFACT CURATION

GUIDELINES FOR THE PREPARATION OF ARCHAEOLOGICAL COLLECTIONS
TO BE CURATED BY THE
UNIVERSITY OF OREGON MUSEUM OF NATURAL AND CULTURAL HISTORY
AND STATE MUSEUM OF ANTHROPOLOGY

1650 East 15th Avenue
University of Oregon
Eugene, OR 97403-1224
July 1, 2010

CURATION CHARGE: There is a one-time charge for accessions for “in-perpetuity” storage, and a minimum charge per submission. It is the responsibility of the submitter to ensure that collections are in order, that documentation is complete, and that these guidelines are followed. Major deficiencies in these areas will result in refusal of collections and their return to the submitter. Minor deficiencies can be corrected by Museum staff but there will be an hourly charge to re-label, re-catalog, or otherwise reprocess specimens or records. The schedule of these charges, which may change from time to time, is attached.

PROCEDURES

1. Curation agreement. Unless approved in advance under an archaeological permit, permission to curate an archaeological collection at the University of Oregon Museum of Natural and Cultural History/Oregon State Museum of Anthropology must be requested in advance in writing. Include nature and approximate volume of material expected. It is understood that actual recovery may differ.
2. Accession number requested. Before the collection is catalogued by the submitter, an accession number should be requested from the Museum. Contact the Director of Collections at 541-346-5120. We recommend, for the convenience of future researchers and Museum staff, that the accession number be identified in the project report if the report specifies where the collection is curated.
3. Accession number placed on specimens and containers. Clearly label all implements with the accession number. (This does not include debitage and other bulk samples; see Labeling.) Your own provenience code/catalog number should follow this number; *each implement should receive a unique designation*. A single accession number can be used for specimens from more than a single site, providing the numbering system serves to label each artifact uniquely.
4. Packaging. Collections should be divided first by site, then by material and artifact class. Subsequent divisions can be either by provenience unit within the site (test pit, quad, level) or by artifact type or both. Bag and label the following materials separately, e.g.:
 - a. small implements that are individually labeled.
 - b. large lithics (choppers, cores, ground stone etc.), also individually labeled
 - c. debitage
 - d. identifiable faunal remains, thoroughly dried
 - e. unidentifiable faunal remains (if any), thoroughly dried

- f. other organic materials (flora, etc.) thoroughly dried
- g. soil or other similar samples, thoroughly dried (double-bag soil)

All bagged materials should be packaged in polyethylene zip-lock bags, paper bags are not acceptable. UOMNCH uses non-archival quality 28" X 6" X 6" boxes for bulk storage. You may keep this in mind when ordering supplies, although we do not require a particular box size.

5. Labeling. All formed/used implements and specially analyzed objects (such as sourced/hydrated flakes) should be individually marked with ink and a sealer such as Paraloid B-72 lacquer or Rholplex AC-33. Exceptions to this are fibers and objects too small, fragile, or brittle to label, which should be individually bagged or boxed with an enclosed acid-free tag. Bulk materials like debitage, soil samples, faunal remains, and aggregate "historic" materials such as unidentified glass and ceramic sherds, pane glass, etc., should be contained in bags labeled with permanent ink on the exterior and with an enclosed acid free tag. Bag labels should minimally include accession number, site number and bag contents/provenience. No adhesive labels, please.

6. Records. Provide the following:

- a. complete printed copy of catalog sheets that clearly identify implements and other items, including bulk materials, and electronic catalog in Excel, Microsoft Access, csv file, or alternate format upon museum's advance approval
- b. complete copy of relevant field notes (originals or legible photo copy on acid-free paper)
- c. papers and bound copies of publications relating to the collections

7. Photographs. All slides, prints and/or proof sheets, and negatives should be delivered with the collection. Documentation must include photo logs identifying images by number with information on subject, aspect, and date. All photographic materials should be submitted in archival protectors (polyethylene or polypropylene three-ring binder sheets).

Digital photos (if present) should be submitted at a minimum resolution of 1600x1200 pixels. Images should be saved in 8-bit format or larger for gray scale, and 24-bit or larger for color, for maximum detail. Each image must have a file name that includes the accession number and an image number that corresponds to a submitted photo log (e.g. MNCH1852_0002). We encourage recording of data such as provenience, subject, and date in file properties (metadata). We do not require a specific file format, though we recommend using the highest-quality settings for JPEG format. In addition to an electronic file, digital images should be printed on resin-coated or fiber-based photographic paper (e.g. HP Premium Photo Papers, Epson Premium Photo Papers), preferably with an inkjet printer. Digital prints should be a minimum size of 3 x 4 inches.

8. Electronic Media. Electronic media (see Records and Photographs) should be submitted on a goldmetal layer, phthalocyanine dye CD-R, such as "Archival Gold". Disks should be enclosed in a paper slip, Tyvek sleeve, or plastic case labeled with the accession number and site number(s). Label the disk itself only on the non-recording surface, which is the clear inner ring. Do not apply adhesive labels to disks. The collection should include a printed inventory of all digital media.

9. Delivery. Delivery of a collection must be arranged with the Collections Manager at least one week in advance (541-346-2853) and take place during the Collections Manager's work hours (Monday through Friday 9:00 to 5:00pm). **ONLY COMPLETE COLLECTIONS WILL BE ACCEPTED** unless other arrangements have been made in advance. Each collection must be accompanied by:

- a. a packing inventory listing the contents of each box
- b. a completed Collections Transmittal Form (supplied by the Museum) including billing instructions

Please note that curation charges are calculated on the volume of the collection as it is packaged at the time of submission. Invoicing to parties other than the archaeological permit holder or land-managing agency should be approved in advance by the Director of Collections.

**GENERAL (NON UOMNCH) CURATIONS STANDARDS AND GUIDELINES
FOR ARCHEOLOGICAL INVESTIGATIONS IN OREGON⁶**

TABLE OF CONTENTS

Introduction 1

Processing, Conservation and Collections Management of Artifacts and Records 2

A. Goal 3

B. Disposition and Curation of Collections 4

C. Oregon State Archaeological Collections 6

D. Processing Material Remains 10

1. Cleaning 10

2. Labeling 10

3. Packaging 12

4. Selective Discarding 14

E. Conservation Standards 14

1. Definitions of Conservation Terms 15

2. Qualifications for a Professional Conservator 16

3. Collections Care Specialist 16

F. Archaeological Materials Which Require Consultation with a Conservator and Conservation Treatments 16

1. Wet Recovery of Material Remains 16

2. Artifacts Recovered from Dry Burial Environments 16

3. Human Remains 17

4. Other Types of Material Remains 17

G. Processing Associated Records 18

1. Required Records 18

2. Labeling 20

3. Packaging 20

⁶ These curation guidelines have been borrowed and slightly modified from Maryland SHPO's *Standards and Guidelines for Archaeological Investigations in Maryland* (Shaffer and Cole 1994).

Introduction

Archaeological collections -- artifacts and their associated documentation -- represent an extraordinary and valuable source of information about past human life and culture. In Oregon, archaeological evidence provides a significant source of information about prehistoric Native American cultures. Archaeological data recovered from sites occupied during the historic period usually contain important information not found in historical documents, and this evidence has greatly expanded our understanding of life in Oregon during the historic period. As new questions about the past and new techniques for analyzing material culture are developed, these collections are examined and reexamined for the potential insights they might yield. Materials from these collections are incorporated into educational programs such as museum exhibits, study collections, and teaching aids in the continuing effort to teach Oregonians about their rich and extensive history. Indeed, archaeological collections are as significant and valuable as the sites from which they come, and their preservation is a top priority of the Oregon SHPO.

Collection means material remains that are excavated or removed during a survey, excavation or other study of a prehistoric or historic resource, **and associated records** that are prepared or assembled in connection with the survey, excavation or other study. This document presents the standards and related discussion on the following items: the goal of the standards, disposition and curation of collections, processing material remains and associated records, and sources of technical information. For conservation services information, contact the Collections Manager at the University of Oregon Museum of Natural and Cultural History (UOMNCH).

A. Goal

The goal of the following standards is to ensure that all archaeological collections generated by professional or avocational archaeologists in Maryland receive the same quality of processing, packaging, documentation, and curation, including stabilization of artifacts or conservation treatment if needed to preserve the artifact(s). Treatment of collections in accordance with these standards will help to provide long-term preservation of artifacts and records for present and future generations.

The terms *curation, conservation, and archival practices* are defined below. **Curation** means *managing and preserving a collection according to professional museum and archival practices.* Curators manage the protection and preservation of collections through the services of professionals in the fields of conservation and collections management.

Conservation means *the preservation of cultural property for the future.* Conservation activities include examination, documentation, treatment, and preventive care, supported by research and education. (*American Institute for Conservation Directory*, 1998, "AIC Definitions of Conservation Terminology," p. 22).

Archival practices are those, which promote the preservation of objects through the use of acid-free housing materials and labels and/or controlled environments. Housing materials may include acid-free boxes, papers, folders, and bags made from non-off-gassing products.

This document outlines overall procedures for the cleaning, labeling, cataloging, packaging, documenting, and curation of collections. The standards included in this document are not intended to substitute for more detailed laboratory methods and procedures. It is assumed that archaeologists will employ applicable current standards of professional knowledge in their curation of artifacts and records. The procedures and materials presented herein meet standards. Archaeological professionals are encouraged to manage and preserve collections according to curatorial and archival practices recommended in professional publications (see Bibliography) and by conservation and collections professionals for treatment and curation of archaeological materials and records.

The Oregon SHPO depends on Principal Investigators and Project Managers to serve as curators for the sites they are investigating and to set priorities for stabilization and conservation of artifacts based on their knowledge of the archaeological resource. UOMNCH's Collections Manager is available to assist Project Managers with collections decisions and will provide recommendations for curation materials and conservation treatments.

The disposition of a project's artifacts and records as a collection should be decided prior to initiation of fieldwork. **Prior to contract award**, project archaeologists should contact the selected repository for its curation requirements. Curation should be identified within the research design.

B. Disposition and Curation of Collections

To ensure the long-term preservation of archaeological materials and associated records, and to provide access to collections, a repository should be selected which meets standards for curation and makes collections available for study. Federal curation standards provide a definition of the term *repository* that is applicable in the U.S. **Repository** means a facility such as a museum, archaeological center, laboratory or storage facility managed by a university, college, museum, other educational or scientific institution, a federal, state or local government agency or Indian tribe that can provide professional, systematic and accountable curatorial services on a long-term basis (36 CFR§79).

A repository should have the capability to provide long-term curatorial services. Required factors include appropriate physical facilities, temperature and humidity controls, security, controlled access, fire protection and suppression, record maintenance and storage, routine inspection, and qualified staff. Collections generated by federal agencies and undertakings must be curated within an appropriate repository.

In addition to considering a repository's technical qualifications, the federal standards offer further guidance on how to select a suitable repository for a collection. In general, it is advisable to curate a collection in a repository which is located in the same state where the collection originated, and which maintains other collections from the same site, project area, or broader geographic region. Collections should not be subdivided and stored in multiple locations, unless such storage is warranted due to conservation, research, exhibit, or other legitimate purposes. Finally, material remains and their associated records should be curated at the same repository in order to sustain the collection's integrity and research value.

The following state and federal facilities in Oregon currently meet the minimum standards for curation repositories:

- **University of Oregon Museum of Natural and Cultural History (UONMCA)**
- **Oregon State University Anthropology Department (OSU)**
- **Southern Oregon University Laboratory of Anthropology (SOULA)**
- **Columbia Gorge Discovery Center**

Situations may arise where a property owner requests to keep the material remains recovered from the owner's property. Under these circumstances, the archaeologist is requested to strongly encourage the owner to donate the collection to a suitable repository by explaining the reasons for appropriate curation and by providing information on incentives for such a donation (tax benefits, recognition in the community, ensuring accessibility for historical research for future generations). A repository may be willing to accept the entire collection and then loan selected items back to the property owner for display or study purposes if the owner satisfies requirements for loans outlined in the repository's collections policy. If a property owner insists on retaining possession of the artifacts recovered from private property, the items must be returned to the owner.

Prior to transferring material remains to property owners who will maintain ownership, the objects should be cataloged, processed, and packaged in accordance with professional standards. In addition, the objects should be thoroughly recorded, including photographing and drawing diagnostic artifacts and other objects critical to the interpretation of the archaeological resources. The Trust advocates the digital scanning of information to make it more accessible. The resulting documentation should be incorporated into any associated collection records, all of which should be deposited in a suitable repository along with a clear identification of the location of the transferred material remains in the owner's possession. Finally, it is recommended that the archaeologist provide the owner with written curatorial recommendations on how to store and handle the collection to avoid or minimize damage and deterioration of the items. The owner should also be supplied with a copy of information on incentives for future donation of the collection to an appropriate repository, and sources for additional technical assistance and advice.

C. Oregon State Archaeological Collections

Archaeological collections curated by the State of Oregon consist of specimens from all periods of American prehistory and history, ranging in date from the Paleo-Indian period of 10,000 to 12,000 years ago through the twentieth century. The artifacts were recovered from archaeological surveys and excavations by state archaeologists, consultants, avocational archaeologists, and private donors. The artifacts and the contexts in which they were found constitute a major part of the surviving record of prehistoric Indians in Oregon. In addition to the artifacts, the state collections contain the associated records (field notes, photographs, maps, etc.) related to the material remains.

D. Processing Material Remains

Archaeological investigations often produce material remains from the area under study. The federal regulations provide the following definition of material remains: *Material remains* means artifacts, objects, specimens and other physical evidence that are excavated or removed in connection with efforts to locate, evaluate, document, study, preserve or recover a prehistoric or historic resource. Material remains may comprise a wide variety of items, including: architectural elements, artifacts of human manufacture, natural objects used by humans, waste or debris resulting from the manufacture or use of human-made or natural materials, organic materials, human remains, elements of shipwrecks, components of petroglyphs or art works, environmental or chronometric specimens, and paleontological specimens recovered in direct physical association with a prehistoric or historic resource. The nature and composition of the material remains will prescribe its specific handling and treatment. However, the general procedures listed below must be followed in the processing of material remains.

1. Cleaning

All artifacts must be cleaned. Professional standards should be followed so as to preserve information. (Exceptions to cleaning: Artifacts designated for special studies, such as blood residue analysis, can be curated in an unwashed state. These artifacts must be packaged separately from the rest of the collection. The packaging must be archival and stable. Containers with these special artifacts must be clearly marked, and any specific instructions must accompany the artifacts. The artifact inventory must note the artifacts' unwashed condition.)

2. Labeling

The value of a collection is in the maintenance of provenience for the cultural material. Good labeling techniques ensure that provenience information is retained. If an artifact becomes separated from its bag or is removed for study or exhibit purposes, the label ensures that the object's provenience is retained and that the object may be returned to its appropriate place in the collection. **a. All artifacts must be labeled with provenience information including, at minimum, the official state site number (or X number for isolated finds) and official state lot number.**

The UOMNCH Collections Manager (or other selected federally recognized curation facility) must be contacted to obtain the next available lot number for any previously recorded site. This requirement is essential, in order to ensure that lot numbers are not duplicated during subsequent work at the same archaeological site.

Archaeologists may add additional designations following the official site and lot numbers, if desired, to suit individual cataloging and analysis needs, e.g., full provenience system utilized. Please contact the Collections Manager for any questions or concerns regarding the lot numbers.

b. Artifacts are to be marked using a clear Acryloid B-72 undercoat before marking, and a topcoat of clear Acryloid B-72 applied to form a protective sandwich around ink. Permanent archival quality ink is to be used. If application of the topcoat smears the lettering by dissolving the base coat, try different ink or apply a coating of Arkon P-90 or Acryloid B-67 as a topcoat, since these resins use a different solvent type (mineral spirits or benzine). Care must be exercised

when using mineral spirits or benzene as the fumes are hazardous to health and the solvent tends to creep across a surface. Dark artifacts can be prepared for marking with an undercoat using titanium dioxide in Acryloid B-72, or marked on an undercoat of clear Acryloid-B72 with archival-quality contrasting waterproof ink. Materials such as gesso are not recommended, as recent studies show that it yellows and peels with time. Polymers such as bakelite, rubber, and plastics should not be labeled, but placed in well-labeled bags. Archaeologists must employ the best current standards of professional knowledge in labeling artifacts with ink, sealant, and white backing when needed. Consult the supply list in the appendix or contact the UOMNCH Collections Manager for a list of acceptable marking materials and procedures.

c. Artifacts too small to be marked, or impractical to mark for other reasons (such as fragility or unwashed condition), are to be placed in perforated polyethylene zip-lock bags (minimum thickness = 4 mil) or other acceptable packaging material (see item 3.a below). Provenience information on the label must include site and lot number, surface area, test pit or unit, and coordinates when available. Bags with small artifacts are then placed in a general provenience bag on which full provenience information, including level/layer, excavator(s), collector(s) and date of collection are to be applied. It must be written in permanent black marker on the bag's exterior, and must be duplicated with permanent, fade-proof ink (such as Pigma) on an archivally-stable tag (such as acid-free and lignin-free paper, Mylar, or tyvek) enclosed in the bag.

d. If individual classes of artifacts are present in bulk (e.g., over 200 pieces of window glass from one provenience), only 10% of the objects need to be individually labeled. These types of artifacts may include: shell, fire cracked rock, flakes, window glass, nails, brick, non-human bone, slag, mortar, and coal. All diagnostic artifacts, however, must be labeled, as feasible. If questions regarding artifact labeling arise, contact the Collections Manager of your selected curation facility.

e. All other classes of archaeological material (e.g., processed floral and soil samples) must be assigned a lot number and appropriately labeled with provenience information.

f. All collections must be accompanied by a catalog (see section F) which includes a key clearly translating the labeling system employed to record the provenience information. The catalog is very important for future use of the collection.

3. Packaging

a. Artifacts must be stored in perforated, permanently marked, polyethylene zip-lock plastic bags (minimum thickness = 4 mil), as feasible. Tiny or delicate objects must be stored in archivally-stable, acid-free materials with appropriate padding and protection (see item D.3.e below). Perforation of plastic bags or other airtight packaging is necessary to allow air exchange and avoid cargo sweat.

b. All plastic bags must be permanently labeled on the exterior and on an interior tag with appropriate provenience information. Provenience information must be written in permanent black marker on the bag's exterior, and must be duplicated with permanent archival ink on an archivally-stable tag (such as acid-free paper, Mylar, or tyvek) enclosed in the bag.

c. Artifacts must be grouped and bagged by provenience, and separated by material type within the provenience. Exceptions may be warranted for small lot sizes and for legitimate research, conservation, and exhibit purposes. Stabilization of some materials such as metals may require microenvironments. However, the documentation accompanying the collection must provide an explanation and justification for the organization system employed.

d. All other classes of material remains (such as floral and faunal samples) must be placed in acceptable, sealed, perforated containers and permanently labeled with the provenience information (including site and lot numbers).

e. Archival-stable, acid-free packing materials must be used for packaging all objects. Fragile and delicate objects must be specially packaged to ensure proper protection during shipping and storage. Oregon SHPO recommends the use of small acid-free boxes padded with acid-free foam core or ethafoam blocks. For oversize items, contact the Collections Manager for appropriate packaging recommendations. The Collections Manager will consult with the state's conservators to provide guidelines for packaging and supporting fragile or oversized artifacts to create safe and archival-stable shipment and storage.

f. All artifacts must be placed in acid-free materials to provide adequate protection for shipping and for final storage at a repository. Artifacts should be packaged by sequential lot number whenever possible, to increase accessibility for researchers. Coroplast boxes are a standard for artifact boxes due to their durability, resistance to wetting, and the ability to create a limited controlled environment.

g. Specialized storage containers or packaging materials may be utilized, if warranted. However, use of alternative materials requires the prior written approval of the Collections Manager at the selected curation facility, due to shelf configuration and space requirements.

h. All artifact containers must have temporary labels to identify the containers' contents, provenience, and lot numbers. The repository will provide labels for storage.

i. Standard boxes or containers should weigh no more than 40 pounds when full.

4. Selective Discarding

Certain types of material **may** have questionable long-term research value and thus may not warrant permanent curation with the collection. These materials **may** include: brick, mortar, slag, coal, shell, and recent 20th/21st century debris (i.e., less than 50 years old). It may be more prudent to discard these items following analyses, rather than to permanently curate the materials with the collection. The collection's catalog must specify the types and quantities of discarded materials, along with a justification for the selected discard, **including means and location**, and a note **in the catalog** that the items were discarded. **The discard of bulk artifacts such as fire-cracked rock, window glass, shell, and other materials is a topic of ongoing national discussion. As curation storage space is filled and curation box fees rise, archaeologists and institutions curating archaeological artifacts are discussing the need for rigorous discard policies that minimize the loss of important archaeological information.**

E. Conservation Standards

Artifacts excavated from archaeological sites should be preserved. Preservation can be accomplished by preventive conservation techniques using controlled environments or by simple cleaning, desalination, drying, and coating. In some cases, full conservation treatments using chemical or mechanical cleaning, electrolytic reduction, and other special techniques are required. A conservator should provide an assessment to determine which artifacts need treatment and what type of treatment would be most effective in terms of preservation and cost. The significance of artifact(s) in terms of curatorial priority must be determined by the principal investigator. Artifacts that are low in curatorial priority or need minimal treatment are best treated with simple stabilization techniques to minimize deterioration, followed by placement in a preventive conservation program, which includes appropriate storage materials, mounts, and environmental conditions. When developing a scope of work, if the nature of the site suggests that artifact conservation will be necessary, a conservator should be consulted and arrangements should be made for consultation during the planning phase and for site visits during excavation. There is no generic prescription for stabilization and conservation of artifacts. Each artifact is individual not only in its significance, which is determined by the principal investigator, but in the degree and type of deterioration. A professional conservator must perform artifact condition evaluations. Through examination of the artifacts, condition and degree of degradation can be established.

The conservator will then be able to recommend the most cost-effective and safest methods for preserving information and artifacts. Recommendations for minimal preservation of the artifacts must include treatment to eliminate conditions causing deterioration. Having a conservator on call while in the field will provide quick response to a request for help, reduce the loss of information through rapid deterioration, and reduce the cost of stabilization and treatment of artifacts.

1. Definitions of conservation terms: These definitions are taken from the *American Institute for Conservation Directory*, 1998, "AIC Definitions of Conservation Terminology," p. 22.

Conservation Treatment means *the deliberate alteration of the chemical and/or physical aspects of cultural property, aimed primarily at prolonging its existence*. Treatment may include intervention by means of chemical or mechanical procedures to remove disfiguring coatings, corrosion products, or stains; to repair objects; and to apply materials to stabilize and protect surfaces of artifacts from handling and environmental changes during future study, interpretation and exhibit. All conservation treatments and information discovered in treatment activities are documented in a permanent archival format. Any treatment process intended to return cultural property to a known or assumed state, often through the addition of non-original material, is called **restoration**.

Stabilization means *treatment procedures intended to maintain the integrity of cultural property and to minimize deterioration*. Stabilization is preservation through minimal intervention to prolong the existence of the cultural property and prevent loss of informational content. Methods of stabilization include control of the environment in which the artifact(s) or collections are

stored or exhibited, mounts, consolidation treatments, surface treatments, simple implementation of maintenance and handling procedures, and pest management.

Preventive Conservation means the mitigation of deterioration and damage to cultural property through the formulation and implementation of policies and procedures for the following: appropriate environmental conditions, handling and maintenance procedures for storage, exhibition, packing, transport, and use; integrated pest management; emergency preparedness and response; and reformatting/duplication.

2. Qualifications for a Professional Conservator

The American Institute for Conservation (AIC), a national association of professional conservators, has established ethical standards for its members. Conservators must have practical experience, a broad range of theoretical and scientific knowledge, and be committed to maintaining high standards and an ethical performance of duties. A copy of the “AIC Code of Ethics and Standards of Practice” is included in the appendix. A brochure guide, “How to Choose a Conservator,” may be obtained from the AIC. The Foundation of the AIC (FAIC) has a Conservation Services Referral System which provides, on request, a computer-generated list of conservators who have met peer review, practice conservation in the specialty of inquiry, and are located near the inquirer.

3. Collections Care Specialist means an individual who is trained and experienced in specific preventive care activities. **Preventive Conservation** is performed by Collections Care Specialists trained in collections care, which includes proper packaging, maintenance of environmental conditions suitable to preservation of the collections, handling of collections, and integrated pest management. They work closely with conservators to maintain the proper conditions for collections.

F. Archaeological Materials Which Require Consultation with a Conservator and Conservation Treatments

1. Wet Recovery of Material Remains: Material remains recovered from submerged sites or waterlogged contexts (such as a marshy area or soil levels beneath the water table) require special handling and treatment to ensure the stability and long-term preservation of the objects. Wet conditions often promote excellent preservation of certain materials, particularly organic remains (such as wood, leather, cloth, and botanical remains). However, once these materials are excavated and removed from their wet environment, rapid deterioration will occur unless the items are appropriately and promptly treated. Projects involving or anticipating the recovery of wet material remains must include provisions and funding for the appropriate treatment of those materials by a trained professional conservator. It is prudent to have a conservator on call to assist in the recovery of wet materials in the field due to the fragility and rapid deterioration of wet materials upon excavation from the burial environment.

2. Artifacts recovered from dry burial environments: Like wet material remains, certain other types of materials also require professional handling and treatment to ensure their long-term preservation. These artifacts have been subjected to wet/dry cycles and are never totally dry. Such items may include metal objects (buttons, buckles, hardware) or organic materials (bone implements, leather), which will deteriorate without proper stabilization and treatment. SHPO

strongly recommends consultation with a professional conservator prior to excavation to determine budgetary needs and procedures for processing materials to best preserve and stabilize the artifacts. Prior to beginning fieldwork, arrangements can be made for a professional conservator to be on call to assist with difficult removal and stabilization of fragile artifacts. SHPO strongly requests the conservation of significant unstable material remains *prior* to curation of the collection and before collections from State compliance projects are submitted to a repository. Items that particularly warrant conservation include those unstable objects recovered from a provenience that is critical to the site's interpretation, as well as exhibit-quality objects. Projects that anticipate the recovery of unstable material remains (such as well and privy excavations or intensive historic site investigations) must include provisions and funding for the appropriate treatment of those materials by a trained professional conservator.

UOMNCH may refuse to accept collections with unconserved or unstable material remains. To maintain a storage environment suitable for long-term preservation, it may be necessary for the repository to refuse storage space for unstable materials that have not been conserved. For additional guidance on the treatment of material remains, contact the State Museum's conservators.

3. Human Remains: In general, the Oregon SHPO does not encourage the excavation and long-term curation of human remains, unless those remains are imminently threatened by natural or human forces, or unless the remains have outstanding research potential. Procedures for the treatment of human remains and associated grave goods may vary, depending on the anticipated final disposition of the remains and the wishes of descendants or culturally affiliated groups.

Treatment procedures must be established *prior* to initiating any excavation of human remains or undertaking a project that anticipates their recovery. Any treatment decisions must conform with applicable federal and state legislation, regulations, and policies.

4. Other Types of Material Remains: Other types of material remains (specimens, flotation and soil samples, etc.) must be appropriately processed before curation. Projects proposing or anticipating the recovery of these types of material remains should include adequate provisions in the budget for appropriate processing and specialized analyses. If sufficient funding is not available for analyses, the materials should be appropriately processed and packaged to ensure their long-term preservation for future analyses. Only soil samples retained for back-up analyses should be curated without prior processing. If not processed, soil samples retained for back-up analyses should be fumigated and/or freeze-dried.

G. Processing Associated Records

Archaeological investigations also generate important associated records, in addition to the materials recovered. 36CFR§79 defines *associated records* as follows: ***Associated records*** means original records (or copies thereof) that are prepared, assembled, and document efforts to locate, evaluate, record, study, preserve, or recover a prehistoric or historic resource. These records may encompass a broad variety of materials including: field notes, maps, drawings, photographs, slides, negatives, films, video and audio tapes, oral histories, artifact inventories, computer disks and diskettes, manuscripts, reports, remote sensing data, public records, archival

records, and administrative records relating to the archaeological investigations. The materials contain essential documentation of the archaeological research and warrant appropriate treatment to ensure their long-term preservation for future researchers. Conservation records are also important documents in the history of the artifacts and contain information about artifact materials, use, and manufacture. These documents are important to the archaeological record and for long-term preservation of collections.

The scope of a given archaeological investigation will determine the kinds of associated records produced for a project. To ensure the most complete preservation for the future, your selected curation facility may request that in addition to the continued submittal of acid-free copies of reports and records, all digital files be submitted in a format which can be migrated according to the best practices currently available. Please consult with the facility's Collections Manager concerning compatible formats for migration of data. The nature and composition of the resulting records will prescribe their specific handling and treatment. However, the following general procedures must be followed in the processing of associated records:

1. Required Records

a. Two archivally-stable copies of all original project records, field and laboratory, should be prepared and submitted for curation with the collection. The original on acid-free paper and one copy on acid-free paper by a heat fusion process (laser and Xerox dry process) are acceptable; any originals that are not archivally-stable must be submitted with two copies on acid-free paper or one acid-free copy with a digital copy. Original records submitted should be legible, unbound, and unpunched. Copies should be double-sided (if feasible), and on 8½" by 11" paper. Digital copies of documents should be in a format that will facilitate migration of data according to best current practices.

b. All associated photographic documentation must be submitted for curation with the collection. Transparency slides, negatives, and contact sheets based on chemical processing are the preferred forms of photographic documentation; however, digital images will be accepted. If submitting digital images, uncompressed TIFF (Tagged Image File Format) files submitted on CDR (not CD-RW) disks are preferred. The CD-R insert must be marked with the date, the name of the project or grant producing the images, the firm or individual submitting the disk, and the name(s) of the photographers(s). An inventory sheet with the same information and also listing the file names, or a print-out equivalent to a contact sheet with a thumbnail of each image, must accompany the disk, preferably in the case insert. Translucent polypropylene cases are recommended for storage of CDs. Label inserts should be on acid-free paper. Do not mark on the CD as the inks may damage the disk.

c. All conservation records, including treatment records, stabilization and assessment records, photographs, and materials analysis data must be submitted for curation with the collection. Conservation records must meet the requirements of section 1.a. above. These records will be kept in the permanent conservation files for artifacts.

d. An inventory of all associated records and a catalog of photographic materials, along with an explanation of labels, must accompany all collections (see section H below).

e. A digital copy of the computerized artifact catalog should be submitted with the hard copy records, if available. Consult the Collections Manager to determine suggested media and format.

Digital information submitted on CD-R (not CD-RW) disks is preferred. Label inserts should be on acid-free paper. Do not mark on the CD as inks may damage the disk. The CD-R insert must be marked with the date, the name of the project or grant producing the data, and the firm or individual submitting the disk. An inventory sheet with the same information and also listing the file names must accompany the disk.

2. Labeling

a. All project records and packaging must contain permanent labels.

Labels must identify, at a minimum, the project name, site number, and date of preparation. Labels should be written directly on the records or sleeves, as appropriate.

b. All photographic documentation must be clearly labeled. Labels must contain, at a minimum, the site number, date the photograph was taken, a description of the subject of the photograph (feature/square, layer/level), and the direction of view, as appropriate.

3. Packaging

a. All records must be packaged using archivally-stable, acid-free materials. Containers must be permanently labeled.

b. All photographic documentation must be stored in archivally-stable, acid-free containers. Contact the curation facility *prior* to packaging for a list of approved materials. Containers must be permanently labeled.

H. Cataloging Material Remains and Records

All collections, including the material remains and associated records, must be inventoried. An itemized descriptive catalog must also accompany each collection. The catalog must provide a detailed description of the items, identifying and classifying the archaeological materials and records according to best current professional standards. The catalog maintains an essential record of the objects represented. Should an item ever become lost, stolen, or deteriorate beyond recognition, the catalog may be the only surviving record of that item. Catalogs are a means of obtaining information about a collection or specific items within the collection without handling the actual objects themselves. A detailed catalog will help minimize the need for subsequent handling of the objects. In addition to item-specific descriptions and provenience, the catalog should specify the collector or donor's name, project name, site Smithsonian and lot numbers, and date of collection.

Catalogs are frequently prepared and maintained in a computer database. The Trust requires that a digital copy of any computer database be submitted with the collection for permanent curation. Two archivally-stable paper (acid-free) copies of the catalog must always accompany the collection. Consult the Collections Manager to determine suggested media and format.

**APPENDIX D: REQUEST FOR REPATRIATION OF ARCHAEOLOGICAL
MATERIAL FROM OREGON NON-FEDERAL PUBLIC & PRIVATE LANDS FORM**

**REQUEST FOR REPATRIATION OF ARCHAEOLOGICAL MATERIAL
FROM OREGON NON-FEDERAL PUBLIC & PRIVATE LANDS**

Name of Requestor: _____

Tribe: _____

As the duly authorized representative of the above stated tribe, I hereby request repatriation of the objects listed below. In our view, these object(s) are either “Sacred Objects” or “Objects of Cultural Patrimony” as defined in state statute and therefore qualify for repatriation.*

Signature of Requestor: _____ Date: _____

Object(s) Requested: _____

Catalog No# _____ Curation # _____

Site# associated with object: _____ State Archaeological Permit #: _____

Report Title: _____

Criteria that object is being claimed under: _____

(i.e., Sacred Object A, B, C; Object of Cultural Patrimony)

Support for Request: _____

For Official Use

___ recommend repatriation

___ approve repatriation

___ do not recommend repatriation

___ disapprove repatriation

Oregon State Historic Preservation Office

Museum of Natural and Cultural History

Date: _____

Date: _____

***Sacred object:** (ORS 358.905(k) – means an archaeological object or other object that:

- (A) Is demonstrably revered by an ethnic group, religious group or Indian tribe as holy;
- (B) Is used in connection with the religious or spiritual service or worship of a deity or spirit power; or
- (C) Was or is needed by traditional native Indian religious leaders for the practice of traditional native Indian religion.

Object of Cultural Patrimony (ORS 358.905(h) – means an object having ongoing historical, traditional or cultural importance central to the native Indian group or culture itself, rather than property owned by an individual Indian, and which, therefore, cannot be alienated, appropriated or conveyed by an individual regardless of whether or not the individual is a member of the Indian tribe. The object shall have been considered inalienable by the native Indian group at the time the object was separated from such a group.

** Any disagreements regarding repatriation are subject to the state’s dispute resolution process (OAR 736-051-0000 to 0050).

APPENDIX E: ARCHAEOLOGICAL MONITORING GUIDELINES

Archaeological Monitoring Guidelines

There are two primary types of archaeological monitoring involved in cultural resource management activities today. These two types include: 1. Construction Monitoring so that known archaeological sites are avoided and previously unknown sites (inadvertent discoveries) can be identified and protected before they are seriously impacted; and 2. Site Assessment Monitoring so as to detect changes in a known archaeological site over time – such as from erosion, cryo/bio-turbation, looting or other on-going processes.

The role and importance of monitoring during land-disturbing activities (Type 1 monitoring) is discussed in Part I, below, with Type 2 monitoring discussed in Part II (page#96) of these guidelines. A third type of monitoring, one less frequently used, involves the use of archaeological monitoring within known sites that are eligible (or treated as eligible) to the National Register but where limited work has been approved. Here monitoring is done to ensure that no cultural features or burials are present that might be damaged or destroyed and to make sure that no archaeological materials unrecovered in completed data recovery collections are exposed. This type of monitoring is treated similar to Type 1 and is discussed within Part I.

Monitoring does not replace the need for Archaeological Survey

Monitoring has recently become a more prevalent CRM practice. Although many archaeologists are uncomfortable with its use as a method of investigation, monitoring appears in many Scopes of Work and Memoranda of Agreement (MOA). Particularly in urban settings, traffic and other logistical considerations have led to a reliance on monitoring, often as a substitute for archaeological testing, evaluation or data recovery. Because power equipment is so costly, monitoring is sometimes presented to agencies and developers as a means to reduce costs of urban archaeological projects, although to their surprise the actual costs can be substantially larger. Too often there is much pressure upon the archaeological community to use monitoring in the compliance process as an alternative to other archaeological field methods. Additionally, there has been little professional guidance on the subject and its appropriateness as an investigative technique remains an open question.

Disadvantages of monitoring over archaeological survey and testing include:

- a. If cultural resources are found during an archaeological survey, it may be possible to adjust the project footprint to avoid or minimize adverse effects. With monitoring, however, the options for project adjustment are more limited and difficult once construction has begun.
- b. Putting the construction crew and heavy equipment on hold while cultural or human remains are being investigated can be expensive. Delays to obtain state archaeological permits, consult with Native American tribes and public agencies, and obtain concurrence on investigative findings may increase the cost of construction considerably.

- c. The archaeologist is under more pressure to rush documentation and excavation of cultural features during monitoring, increasing the chances of mistakes or omissions of data.

The decision to employ monitoring on a given project must be considered on a case-by-case basis. Oregon SHPO does not support the use of monitoring as a general survey strategy but recognizes that it may be an appropriate investigation strategy in limited situations. Investigators should consult with SHPO concerning the scope of work for archaeological monitoring as the project proposal is developed.

I: ARCHAEOLOGICAL MONITORING DURING CONSTRUCTION (INADVERTENT DISCOVERY)

When archaeological resources are either known or anticipated in an area, construction monitoring may be required by state or federal review agencies to ensure that cultural resources are not inadvertently disturbed or destroyed by the proposed project. This is often the case when existing facilities (e.g., pavement, etc.) prohibits the archaeological survey of a location, when sites may be so deeply buried that they cannot be reached using standard archaeological survey techniques, or when portions of sites have undergone data recovery excavations but the potential of buried features or significant artifacts still remain.

The goal of Type I archaeological monitoring is to assess the presence/absence of archaeological deposits in: 1. areas that could not be examined by Phase I survey (e.g., buried cultural deposits); 2. areas of high probability and low visibility where subsurface probing was not possible (e.g., areas below pavement or covered by thick overburden); and 3. areas where subsurface probing yielded negative results but the likelihood of buried intact features remains high. Monitoring may also be employed to ensure that features or significant deposits within known sites within a project area are not impacted by ground-disturbing activities if disturbance to such sites has already been mitigated through data recovery.

For purposes of this document, we define monitoring as the observation of construction excavation activities, as they are occurring, by an archaeologist in order to identify, recover, protect and/or document archaeological information or materials. During monitoring, excavation is not under the control of the archaeologist although the archaeologist may be given authority to temporarily halt construction work to do his or her job, as defined in the scope of work. Excavation area, location and depth are determined and directed by the construction contractor(s), or the organization employing them.

The practice of monitoring should not be confused with the use of heavy equipment by archaeologists. In this circumstance, the placement, size and depth of the excavations suit the aims of the archaeological research design and the operation of all mechanical equipment is under direct control of the archaeologist.

When Monitoring is Appropriate

The State Historic Preservation Office (SHPO) occasionally recommends that an undertaking be archaeologically monitored. An archaeological monitor should meet the Secretary of the Interior's (SOI) Standards for an Archaeologist (36CFR§61, Appendix A), or at a minimum meet the federal OPM Standards for a professional archaeologist (<http://www.opm.gov/policy-data-oversight/classification-qualifications/classifying-general-schedule-positions/standards/0100/g0193.pdf>).

Archaeological monitoring requires the presence of an on-site archaeological monitor during the earth moving portions of a project. Monitoring involves close scrutiny of newly exposed soils in order to identify potentially significant cultural resources. The archaeological monitor keeps detailed field notes and takes photographs throughout the earth-moving activities. If the monitor detects artifacts or archaeological features that may be significant, he or she stops work in the area. Usually, when a discovery is made, construction activities will be placed on hold until the reviewing agency, in consultation with the archaeological monitor, determine the find's significance. Such determinations need to seek SHPO concurrence and to determine what further actions need to be taken before work can proceed. In cases where a site is determined significant, further archaeological work, such as Phase II Testing or Phase III Data Recovery, may be required. Effective monitoring is provided when the archaeological monitor knows the resources of a given area and can assess whether discoveries require further consultation. All assessments regarding the NRHP-significance of a find must be made by an archaeologist who meets the Secretary of the Interior's (SOI) Standards for an Archaeologist (36CFR§61, Appendix A).

If a decision is reached to proceed with monitoring, then a written monitoring plan or protocol must be implemented. The contents of such a document are described below. With the exception of extraordinary circumstances (e.g., excavations to permit emergency repairs) an acceptable plan should give the archaeological monitor the authority to halt excavations under defined conditions.

Specific scenarios based on actual examples are presented here to establish guidance in how and when monitoring is appropriate.

Scenario 1) Accessibility is often an issue when planning archaeological testing in urban areas. Monitoring may be appropriate in projects where impact areas have the potential for containing archaeological resources but cannot be investigated in advance of construction due to the presence of buildings, roads, or other structures. Another example of such an instance would include heavily trafficked urban areas where it was not feasible to excavate the streets twice, for both archaeology and construction. As a result, archaeologists are sometimes not given access to the sites prior to construction. In both cases detailed monitoring plans need to be developed whereby the archaeologists work closely with the excavating contractors to document archaeological resources.

Scenario 2) Monitoring may be appropriate when known archaeological resources are in close proximity to the footprint of planned construction excavations or when known archaeological resources are located at a depth below which construction excavations are planned. In such

circumstances monitoring is undertaken to ensure that construction stays within specified limits and/or, should the site be more extensive than previously defined and archaeological remains encountered, to ensure that they are documented or avoided.

Here monitoring can be done to ensure a contractor does not exceed the depth of planned construction and that the more deeply buried sites are not disturbed. Another example would include areas where landscaping has the potential to disturb an historic burial place. The archaeologists would work with the contractor to document any exposed remains which could then be protected *in situ* and trench depths modified.

Qualifications for Archaeological Monitoring

Archaeological monitoring must always be conducted under the direct supervision of a qualified archaeologist that meets the Secretary of the Interior's (SOI) Standards for an Archaeologist (36 CFR Part 61, Appendix A). The on-site archaeological monitor does NOT have to be SOI-qualified, but MUST have immediate access to a supervising SOI-qualified archaeologist. The responsibility of the on-site archaeological monitor is to watch for archaeological materials, to quickly halt activities in that area if potential NRHP-significant materials are found, and to notify the SOI-qualified archaeologist. The SOI-qualified archaeologist is responsible for assessing the potential NRHP significance of any archaeological materials identified during monitoring and for initiating any consultations with agencies or the SHPO regarding these materials. In some cases it may be preferable that the on-site monitor also be an SOI-qualified archaeologist, but for most projects the on-site monitor acts as the initial eyes and voice of the SOI-qualified archaeologist.

Thus, the on-site archaeological monitor must be *knowledgeable* and *alert* to successfully monitor a ground disturbing activity--*knowledgeable* in being able to recognize archaeological artifacts, features, or potential cultural-bearing sediments that may be exposed, and *alert* in being able to see these materials amid the potentially large amounts of soil being displaced by heavy equipment and to quickly act to halt operations so that these items/features can be positively identified.

Qualifications for Archaeological On-Site Field Monitors

An archaeological on-site field monitor must have extensive experience with the archaeological materials (artifacts, features, sites) and with the sediments and geomorphic setting of sites that may be expected in the vicinity of the monitored action. Monitors should have a bachelors or graduate degree in archaeology, anthropology, or closely related field, but this not a prerequisite if sufficient experience can be demonstrated. A monitor with a bachelor's degree (or less) should have a minimum of 24 months of active fieldwork experience in the geographic or cultural region of the monitored action and/or laboratory processing/analysis of materials from the geographic region. An advanced degree is NOT a substitute for needing field experience and such monitors should have a minimum requirement of 12 months direct experience with the archaeology of the region in which the monitored action occurs.

Qualifications for Supervision of Archaeological Field Monitors: SOI-qualified Archaeologists

36 CFR Part 61 states: "The minimum professional qualifications in archeology are a graduate degree in archeology, anthropology, or closely related field plus:

1. At least one year of full-time professional experience or equivalent specialized training in archeological research, administration or management;
2. At least four months of supervised field and analytic experience in general North American archeology, and
3. Demonstrated ability to carry research to completion.

In addition to these minimum qualifications, a professional in prehistoric archeology shall have at least one year of full-time professional experience at a supervisory level in the study of archeological resources of the prehistoric period. A professional in historic archeology shall have at least one year of full-time professional experience at a supervisory level in the study of archeological resources of the historic period."

In addition to these basic SOI requirements, it is *highly* recommended that an SOI-qualified archaeologist who is supervising archaeological monitors/monitoring have at least 3 years of direct supervisory archaeological field experience in the geographic region in which the monitored action occurs.

Monitoring Methodology

- Monitoring of excavations within a known archaeological site must be conducted under a monitoring plan developed in consultation with the Oregon SHPO. This consultation will determine whether an SOI-qualified archaeologist must be on-site during the monitored excavations (recommended) or whether archaeological monitors (as defined above) under direct supervision of the SOI-qualified archaeologist can be the on-site monitors (e.g., in situations where planned excavation is in an area of the site with known low artifact density based on previous archaeological test excavations, or at sites known to have discontinuous cultural deposits). Selection of the SOI-qualified archaeologist should be based upon the type of archaeological deposits anticipated to be encountered. If the site to be monitored is prehistoric, an experienced prehistoric archaeologist should be selected; for historical sites a historical archaeologist familiar with the area and with the type of site is needed. Furthermore, expertise in identifying historic vs. modern era artifacts, human vs. faunal remains, or intact vs. disturbed or redeposited soils can be essential in the identification and distinguishing of observed resources resulting in fewer delays and a cost savings to project proponents.. Selection of a prehistoric- or historic-qualified archaeologist should be based upon the type of archaeological deposits anticipated to be encountered. For example, expertise in identifying historic vs. modern era artifacts, human vs. faunal remains or intact vs. disturbed or redeposited soils can be essential in the identification and distinguishing of observed resources resulting in fewer delays and a cost savings to project proponents.

- An archaeological monitor, under the direct supervision of a SOI-qualified archaeologist, should be present for all excavations within high-site-probability areas. Excavations in low-site probability areas do not need to be continually monitored but must be regularly inspected as the excavation proceeds.
- In the event human remains are encountered during an archaeological monitoring project, work must stop immediately in the vicinity of the uncovered human remains. Immediate notice regarding the discovery should be made to the Oregon State Police. The state police shall assess the nature and age of the human skeletal remains and whether the remains are related to a crime scene. If the human skeletal remains are determined to not be part of a crime scene and are Native American, the Commission on Indian Services (CIS), Oregon SHPO, and the appropriate tribes should be contacted (ORS 97.745(4)). No remains should be removed until jurisdiction is established and, if the remains are Native American, until the appropriate tribe(s) have been consulted.
- Many federally recognized Indian tribes in Oregon request that a tribal monitor be on site during construction or excavations within a known site. Oregon SHPO acknowledges tribal concern and supports their right to request the presence of a tribal monitor. The presence of a tribal monitor, however, is not in lieu of having a professional SOI-qualified or archaeological monitor on site. The professional (as described above) is still required under all circumstances.
- At the discretion of the archaeological monitor, excavation or other ground-disturbing activities must be halted any time a suspected archaeological feature or deposit is encountered. Excavations in the area of the discovery must remain halted until the archaeologist can determine the nature, extent, and age of the archaeological deposit. Once it has been determined that the discovery represents an archaeological site, a state archaeological permit is needed before any additional investigation can occur to the site. If the initial examination determines the deposit may have sufficient integrity and content to be considered potentially eligible for nomination to the National Register, all further excavations in the vicinity of the deposit must be halted until a complete eligibility determination can be made. Concurrence is needed from SHPO for all eligibility determinations, whether recommended as not eligible or eligible. While an examination of the site is underway, further project excavations outside of the find location (i.e. with the placement of a 10 meter protective buffer) may proceed with continued monitoring.
- A monitoring report must be prepared that includes a map showing the locations of all excavations, surface structures, topography, and identified archaeological deposits within the portion(s) of the project area where archaeological monitoring is occurring. A description of observed soils and any noted disturbances should be included in the report.
- Circumstances that limit or prevent visual examination of project excavations must be described in the report and the unexamined or minimally examined areas delineated on a project area map.
- Representative profiles of all excavations should be recorded in the field by both photographs and illustrations. It is important to note that under Oregon state law (ORS358.920) no soil disturbance or collection of artifacts within an identified site can occur without first

obtaining a state archaeological permit. A state archaeological permit is also required prior to any probing or ground disturbing activities to locate the presence or absence of a site on public lands in Oregon (i.e., state, county, city lands). In some instances, it may be appropriate to apply for an archaeological permit in advance of monitoring based on a monitoring plan and the likelihood of sites being found.

Monitoring Plan

When monitoring is planned, a clear understanding between the archaeologist and construction excavation team (from the management level down to the equipment operator) is required prior to commencement of fieldwork. A protocol for construction work stoppages must be developed to enable archaeologists' time for recordation and for any archaeological data recovery that may be needed.

For projects in which monitoring is being proposed, a written protocol or monitoring plan should be prepared and agreed to by the consulting archaeologist, the review agency archaeologist, the undertaking agency representative, the developer (where applicable), and the construction contractor. The monitoring plan should include a number of essential elements:

- The authority of the archaeological monitor to halt excavations to allow for agreed upon investigations should be clearly stated. This authority should also be conveyed to all levels of the contractor's on-site excavation team, including the equipment operator(s).
- Identification of areas within the project that are archaeologically sensitive and need to be monitored. The amount of time during which construction excavations are to be made available for archaeological work should be clearly stated in the plan. This should be specific. A formula appropriate to the nature and size of the site should be developed (e.g., one monitor per piece of construction equipment; monitoring needed during ground disturbing activities up to reaching a particular depth, or monitor required only in specific areas under specific types of ground disturbing activities).
- The nature of the archaeological work within the contractor's excavations (e.g., photography, drawing of profiles, screening of removed soil for artifacts, taking of soil samples, hand excavation, etc.) should be clearly stated as well as the objectives of the archaeological work. The types of resources which may be encountered based on preliminary research or the results of prior excavations in the area should also be stated.
- The actions to be taken by archaeologists, should artifacts requiring further study be encountered during construction, must be explicitly stated. The protocol for consultation and decision making required in order to slow down or halt construction activities (e.g., consultations with construction, engineering and agency personnel), including identification of specific persons to be contacted, should also be stated. The amount of time that archaeologists will have to record and/or excavate such remains should also be agreed upon. This can be stated as an amount of time for each cultural resource encountered and/or a total amount of time for the entire project.

- The assumptions under which time estimates are made should be clearly stated, both relating to physical site conditions and to archaeological situations. For example, if the monitoring plan assumes warm weather conditions, the need to change the plan or schedule under winter conditions should be stated. The need for a change in scheduling due to unanticipated archaeological finds should also be spelled out.
- Assistance to be provided to the archaeological team by construction personnel (e.g., pumping of water from excavations, shoring of trenches, construction of shelters under winter conditions), including those actions mandated by OSHA regulations, should similarly be specified.
- Actual procedures should be specified in case construction plans are changed during the course of the construction work. These procedures must provide adequate time for the archaeologists to consider the sensitivity of the additional locations and/or depths of construction to be affected by the new plans and to enable all parties to consider and agree to any modification of the monitoring plan which may be necessary.
- As with any archaeological plan, treatment of artifacts, technical analysis of samples, curation, preparation of reports, etc. should be addressed in the monitoring plan.

General monitoring guidelines

1. If cultural resources are encountered:

- a. Halt any construction work that may impact the cultural remains. May be able to re-direct construction activities to another area (e.g., place 10 meter buffer around discovery);
- b. Consult with lead agency and SHPO regarding the significance of the discovery and further action to be taken. If a site is discovered during monitoring and it can not be avoided, a state archaeological permit may be required to evaluate the discovery before work can commence in the area of the find.
- c. Follow agency and SHPO recommendations regarding documentation and data recovery of the material.

2. If human remains are encountered:

- a. Halt any construction work that may impact the human remains. May be able to re-direct construction activities to another area;
- b. Contact the Oregon State Police, lead agency and land manager (if different), SHPO, CIS, and appropriate tribes;
- c. May need to have remains analyzed by a physical anthropologist to determine ethnicity;
- d. If human remains are on non-federal public land, need to follow state burial laws (ORS 97.740). If on federal land, follow NAGPRA procedures. Otherwise, follow recommendations of SHPO regarding reburial. SHPO will coordinate with appropriate tribes and State Historic Cemetery Commission as appropriate.

e. Consult Oregon Tribal position paper on *Treatment of Human Remains Discovered Inadvertently or Through Criminal Investigation on Private and Public, State Owned Lands in Oregon*(<http://egov.oregon.gov/OPRD/HCD/ARCH/docs>) so the tribal concerns over impacts to and relocation of discovered human remains can be considered.

3. Defining Archaeological Site Boundaries Discovered During Monitoring

a. If archaeological deposits are encountered and can not be avoided through project redesign, the boundaries and significance of the deposit (site) may need to be delineated. An Oregon State archaeological permit will be needed before any subsurface investigations takes place within the boundaries of an archaeological site (ORS 358.920(1)(a); 390.235(1)(a)).

b. If a site is identified during stripping, slab removal, or other surface exposure, delineation via shovel-tests to ascertain the limits is appropriate.

c. If a site is identified within a mechanically excavated trench and shovel testing is not practical, cores or augers should be used to define site limits to avoid substantial impact to the site through numerous trenches. If further mechanical excavation is necessary, it should be limited to the minimum number of trenches necessary to provide approximate site limits. Strategies for defining and refining a site's boundaries need to be discussed with SHPO and incorporated in the approved state archaeological permit.

d. Locations determined to be archaeological sites (10 or more cultural items or a cultural feature; 50 years old on federal land/75 years on non-federal) must be documented with completion of a State of Oregon Archaeological Site Record form. All required data, including UTM coordinates for location, must be included. This form should be included with the report on the monitoring investigations.

e. Locations of cultural materials that are at least 50 years old on federal land/75 years on non-federal public or private land, but do not meet other qualifications for being recorded as a site (i.e., fewer than ten items or a cultural feature) should be considered Isolated Finds and recorded on an Isolate Find Form that will be included in the report on the monitoring investigations.

f. At the completion of the monitoring, investigators must assess if an identified site is eligible, not eligible, or undetermined for nomination to the National Register of Historic Places. Documentation for these assessments should be provided in the report submitted to Oregon SHPO.

g. A site form or site update form must be filed for every site identified or revisited during a monitoring project where change is noted. If no change in a previously identified site has been noted (e.g., change in site size, integrity, composition) no update form is needed but the monitoring observations need to be included within the report.

4. Collection Standards

a. If backhoe trenches are employed, investigators must retain all diagnostic artifacts and a representative sample of non-diagnostic items recovered from disturbed contexts (backdirt piles, wall scrapings, etc.). All artifacts, including bulk materials, must be retained from undisturbed contexts (i.e., midden lenses or features exposed in trench walls). After counting or weighing in the field or lab, bulk materials such as brick, mortar, plaster, shell and gravel may be discarded except for a 10% representative sample or other approved amount (as referenced in the research design) per provenience. The collection and curation strategy must be included within the state archaeological permit.

b. If shovel tests are employed, collection standards are those as explained in the state archaeological permit.

Collection standards (i.e., recording provenience data, analysis, curation and reporting) for recovered artifacts during monitoring are the same as those found during formal excavations.

II. MONITORING OF KNOWN ARCHAEOLOGICAL SITES THROUGH PERIODIC INSPECTIONS (CONDITION ASSESSMENT)⁷

As noted at the beginning of these guidelines, Type 2 monitoring is an entirely different kind of monitoring from Type 1. The function and goal here is to detect changes in a known archaeological site over time, whether those changes are due to erosion, deposition, compaction, cryoturbation, bioturbation, looting, unauthorized vehicular traffic and other disturbances, or other on-going processes. Type 2 archaeological site monitoring of this type consists of periodic visitations and inspections to detect change in a site's condition and does not involve the use of heavy equipment (unlike construction monitoring). Archaeological resources are vulnerable to both intentional and inadvertent damage from many sources, and the level of risk to individual sites is not static. Changes in access (e.g., new roads or trails), pool levels in lakes and rivers, the nature or location of military training, agricultural practices, urban and suburban expansion, or recreational activities can expose archaeological resources to new risks.

Site monitoring is an important but neglected aspect of Cultural Resources Management (CRM). The laws, regulations, and policies that are the basis for national, state, and tribal historic preservation programs clearly specify requirements for identifying archaeological resources and evaluating their eligibility for the National Register of Historic Places (NRHP). A substantial body of professional literature, guidelines, and standardized practice has developed for these CRM activities. In contrast, the need for systematic monitoring of recorded sites is implied by requirements to protect historic properties, but is not discussed in detail. Site monitoring is thus often seen as an activity that is important but less critical than site discovery and evaluation. Given limited funding, many CRM programs focus their monitoring efforts on a very narrow range of highly sensitive and/or highly visible sites, such as rock shelters, rock art, mounds, cemeteries, and battlefields that are primarily threatened by looting and vandalism. Such efforts may (depending on field protocols and data management) be adequate for those sites, but highly selective monitoring is not sufficient for compliance with the intent of relevant historic preservation law.

Legal Requirements for Site Monitoring

The National Historic Preservation Act (NHPA) of 1966 (as amended) plays a central role in the nation's historic preservation and CRM programs. Section 110 of the NHPA requires agencies to "establish ... a preservation program for the identification, evaluation, and nomination to the National Register of Historic Places, and *protection* of historic properties" (Section 110, 16 U.S.C. 470h-2) (emphasis added). Little guidance is provided as to how this protection can be accomplished. Nevertheless, this mandate to protect historic properties clearly demands an awareness of potential threats and changes (i.e., deterioration) in a site's condition.

Archaeological sites are at risk of being adversely impacted even before they have been identified and evaluated by a Federal agency or other organization. Many sites are discovered

⁷ This section of the guidelines has been largely taken from the US Army Corps *Best Practices for Archaeological Site Monitoring* Public Works Technical Bulletin No. 200-1-60 (2009).

during the course of a field survey conducted in compliance with NHPA's Section 106, which require Federal agencies to "... take into account the effect of the undertaking on any district, site, building, structure, or object that is included in or eligible for inclusion in the National Register." Field surveys (supplemented by archival research) are designed to locate historic properties that may be impacted by planned or possible future undertakings. Available funds often permit the assessment of only a few sites per year, leaving many sites in the category of "potentially eligible." Both NRHP eligible and potentially eligible sites are vulnerable to a wide range of adverse impacts. Protecting historic properties (including archaeological resources) as mandated by NHPA clearly requires that sites be revisited periodically to ensure that they are not being damaged by natural processes or cultural activities.

Sources of Adverse Impacts to Archaeological Sites

Adverse impacts to archaeological resources can result from a wide variety of sources. Not all of these impact sources will be relevant to any particular site. Individuals who develop monitoring strategies should, however, be certain that their field protocols are designed to capture evidence for all potentially relevant threats.

Natural impacts

Over time, the condition of many sites is altered by natural processes. Of greater concern, however, are the relatively short-term, intense effects of natural processes that are exacerbated by human actions and/or climate change. For example, excessive rainfall can lead to the development of erosional gullies. Adverse effects associated with gullies (the horizontal and vertical displacement of artifacts, soils, and sediments) can become far more intense when new construction (e.g., large paved parking lots), fire, or vegetation clearing cause changes in local drainage patterns. Bank erosion can lead to severe damage to sites located near lakes or streams that see increases in commercial or recreational boating or changes in pool levels. Bank erosion can also make sites more vulnerable to looting if artifacts or features are exposed. Wind erosion is also a serious threat to archaeological deposits, and its adverse effects can be greatly increased by loss of vegetative cover caused by climate change or land use patterns (e.g., over-grazing). When strong winds cause trees to tip over, archaeological deposits near the trees' root systems can be displaced. Wind patterns can shift as a result of major changes in climate (e.g., an increased frequency of storms), but tree tips also become more common as a forest ages. Burrowing animals (e.g., badgers, gophers, ground squirrels) can damage stratigraphy and displace artifacts. They can become more destructive in some areas as human changes in land use (e.g., urbanization) force their populations to relocate. Site impacts caused by the hooves of herd animals can endanger previously undamaged sites when grazing patterns shift.

Cultural impacts

A far greater number of sites are seriously damaged or destroyed by human actions than by natural processes. Among the most destructive are land modifications (e.g., grading) associated with urban/suburban development (including the construction of both roads and buildings) and agriculture. Mechanized agriculture has homogenized the upper-most portions of many sites, whereas deep plowing and land leveling for agricultural purposes has resulted in the total

destruction of many others. Modifications to stream channels and the construction of lakes have impacted a disproportionately large number of sites because human occupation has long favored areas near water sources and travel routes. Military training and the construction and maintenance of associated infrastructure are major sources of site destruction. Heavy vehicle traffic can lead to a loss of vegetation, greater erosion, compaction or mixing of soil strata, fragmentation and displacement of artifacts, and destruction of architectural remains and other features. Recreational vehicle traffic is the source of similar impacts, albeit on a smaller scale. Commercial and recreational boating can increase bank erosion due to wave action.

Looting (unauthorized excavation) and vandalism are major problems, in part because they are strongly focused on particular site types, including cemeteries, caves and rock shelters, rock art, and rich habitation sites. Effects of looting range from the removal of diagnostic artifacts from the surface to large scale uncontrolled excavations, desecration of graves, removal of rock art, and the introduction of painted or etched graffiti. Motivations for looting are highly variable. Small-scale looting by hikers, hunters, and others may be entirely unpremeditated. Artifact collectors who damage sites are often seeking to build their own collections, whereas “professional” looters range from impoverished indigenous people with few alternatives to relatively educated, non-local individuals motivated by greed. A well-established international market for antiquities ranging from projectile points and ceramic vessels to the rarest religious and culturally significant objects provides a strong incentive for commercial looters.

Monitoring Plan

A site-monitoring strategy developed for the management of historic sites or “places” involves the repeated collection of a specific set or sets of information over time and analyzing the results to detect the changes that are occurring which may lead to management recommendations for treatment. All managed sites require some degree of monitoring to detect the nature and rate of site attrition, risk to certain sites or categories of sites, etc. The most important aspects of a monitoring strategy are ease of recording, repeatability, cost-effectiveness and the avoidance of subjective assessment.

An initial, baseline visit that involves the collection of detailed information is important to provide guidance on the type and amount of information to be collected during subsequent monitoring visits. Monitoring visits typically conform to a schedule, and if site condition is stable, may involve little more than an updating of records. The use of standard terminology and definitions for common terms describing quality of preservation (good, fair, poor, etc.) should be defined and agreed upon.

Photography plays a central role in monitoring strategies. Aerial photographs can be extremely useful, particularly for large sites and those covered in grass. Standard (ground-based) photographs taken during monitoring visits provide a basis for detecting changes in site condition. “Photo-points”—carefully chosen control locations from which photographs should be taken during successive monitoring visits provides an effective way to detect change. Photo points should be numbered and unobtrusively marked. A monitoring program should generate a substantial body of archive material including checklists, condition reports, and photographs.

Details as to how this can best be done can differ greatly between projects and should be developed and approved before initiating such a regime.

The examination in the field of photographs from previous monitoring visits is a basis for detecting recent changes. The goal is to identify the presence or absence of impacts and to determine if they have been “active” (worsened) since the last visit. Large impact areas such as those caused by erosion are delimited by taking multiple GPS readings and mapping the affected area. Photographs are taken from the same location and view during each monitoring visit, and a detailed photo log is maintained, including the requirement for a narrative description of each photograph’s subject, view (compass bearing), etc.

Verifying site locations is an important task in the initial monitoring visits. Prior to the ready availability of hand-held global positioning system (GPS) units, site locations were plotted onto aerial photographs and Universal Transverse Mercator (UTM) coordinates were later calculated in the laboratory. Use of GPS has demonstrated that site locations were sometimes substantially in error. Location errors of this kind are likely to occur throughout the United States. One way to integrate GPS into a site-monitoring strategy is to collect location data for not-likely-to-be-collected artifacts. Relocating these artifacts and comparing their location with previous readings during subsequent visits could yield important data on depositional changes at work (e.g., sheet erosion, etc.).

For example, monitoring visits within a reservoir scenario may document a range of impacts including surface erosion, gullyng, bank slumping, arroyo cutting, eolian (wind) activity, and site visitation (e.g., by hikers). When impacts are observed, monitoring individuals need to make recommendations about the treatment needed then consult with specialists (e.g., in vegetation, trail maintenance) in assessing the type of remedial action needed to prevent additional impacts.

Collection of Baseline Data

Initial (baseline) monitoring visits need to be conducted by individuals who meet SOI qualifications and should focus on updating the site form (including the acquisition of GPS data) and photography. The goal is to determine current site conditions and the relative level of disturbance. Baseline monitoring procedures include a general evaluation: walk the site, locate the boundaries, search for human and natural impacts, and take photographs from each corner of the site and elsewhere as needed. Erosion, agricultural, grazing, and construction impacts will be documented using GPS and photography: Photographs should be taken from the same position on the site, oriented in the same direction every year/visit to ensure comparability of results. Evidence of artifact collecting and looting will be recorded on the site form and documented with photographs. That information will be passed on to law enforcement personnel.

Routine monitoring can be conducted by individuals who do not meet SOI qualifications stipulated in 36 CFR Part 61. Such monitoring visits will focus on the collection of GPS and photographic data that can be compared with data from previous visits in order to detect the existence and magnitude of changes in site condition.

When developing a monitoring plan, however, each of the best practice features should be evaluated in terms of its costs and benefits, and the implications of its exclusion from the strategy.

Identify Goals

Collecting and managing information about the condition of a large number of sites is time consuming and expensive. Given the limited resources available to most CRM programs, every hour allocated to one effort detracts from another important effort (e.g., site survey, NRHP evaluation, curation, report preparation, public outreach). It is not a good use of limited resources to collect and manage detailed information that does not contribute directly to one's goals. Existing strategies should focus on several goals. All share the fundamental objective of detecting change in the condition of archaeological resources. More specifically, monitoring should focus on changes in the condition of those characteristics that make a site eligible for the NRHP. Typically those characteristics relate to two properties: (1) integrity and (2) meeting the requirements of one or more of the four NRHP eligibility criteria. For example, an archaeological site that is eligible for the NRHP based on its prehistoric deposits may also include the remains of an abandoned but recent historic structure that does not contribute to the site's eligibility. It would be useful to record during monitoring visits evidence that the building has recently been vandalized, since that would alert cultural resource managers to a possible threat to the prehistoric deposits. It would not be cost effective, however, to record highly detailed observations about the building's condition.

Identify Possible Impacts

The nature of factors that can result in adverse impacts to archaeological resources can vary greatly. The types of potential impacts to be included on monitoring forms should be selected by individuals who have visited many sites in the region, and who have done enough site excavation to have an understanding of how particular processes or actions can damage archaeological deposits. Table 1 provides an incomplete list of possible impacts that can be used as a point of departure.

Table 1: Partial list of natural and human impacts to archaeological resources.

Agricultural and Grazing Impacts

- Shallow plowing and disking
- Deep (chisel) plowing
- Land leveling, terracing
- Wheeled vehicle traffic
- Removal of trees
- Excavation of drainage ditches
- Installation of drainage tiles
- Discard or loss of equipment parts
- Artifact collecting
- Construction of fences
- Soil churning from animal hooves
- Vegetation loss and erosion from over-grazing

Infrastructure Construction and Maintenance

- Earth moving (grading, trenching)
- Removal of trees and vegetation
- Excavation of drainage ditches
- Paving and other changes to local drainage
- Excavation of cellars, utility lines
- Road construction

Lakes and Streams

- Bank erosion from wave action, changes in pool level
- Construction of check dams, etc.
- Construction of boat access ramps, piers, etc.

Recreation

- Construction of access roads, trails, fire breaks, parking areas, etc.
- Increased visitation (artifact collecting, erosion, vandalism)
- Wheeled vehicle traffic

Military Impacts

- Tracked vehicle ruts
- Wheeled vehicle ruts
- Vegetation damage, erosion
- Munitions impact craters
- Mechanized excavation (e.g., defilades)
- Hand excavation of fighting positions (i.e., “foxholes”)
- Bivouac impacts (trash discard, vegetation clearing)
- Artifact collecting
- Fuel, oil, or other spills
- Grading to remove remains of civilian architecture

Animal Impacts (other than livestock)

- Rodent burrows, tunnels, dens
- Wallows

Insect Impacts

- Earthworms, etc.

Wind Erosion

- “Normal” aeolian processes
- Storm surges

Cryo/bio-turbation, Earthquakes, Landslides, Hurricanes, Forest Fires

Develop Field Monitoring Forms

Field forms should require adequate information about site location (including accurate GPS data), site surface and vegetation conditions, and access. For those who design the field monitoring form, the goal is to prompt field personnel to make and record the observations needed to detect and measure changes in relevant aspects of site condition. At the same time, the form should not require field personnel to allocate time and enthusiasm to needless detail. Forms

should be well-organized; for example, location information should not be interspersed with aspects of site condition. All terms should be unambiguous. The form should be organized to maximize the specificity of observations.

Forms should use a “multiple choice” format when possible to minimize the amount of narrative writing. Short “essay” answers should be required, however, when it is important to elicit observations that are difficult to quantify or categorize. The form should be designed and updated as needed to ensure that no ambiguity or errors are introduced when data from the form are entered into an electronic database or other software tool. For example, a common difficulty encountered when querying a database is the use of multiple variants for a single term, requiring a potentially significant amount of data cleanup before data can be used. Newly developed monitoring field forms should be tested during visits to a wide variety of sites. The decision whether to use paper or digital field forms is a significant issue. Paper forms are immune from technology glitches but can, of course, be damaged or destroyed by moisture. Use of digital forms with a laptop computer or handheld “personal digital assistant” (PDA) offers advantages such as avoidance of transcription costs and errors.

Disadvantages may include the device’s initial cost, reliability, and eventual obsolescence. Revising digital forms and data management programs to ensure continued viability may be a minor task in some cases or a significant expenditure in others.

Detecting change, particularly when it concerns the subtle, initial stages of site deterioration, demands consistent observations through time and among different individuals. The only way to achieve such consistency is to develop detailed, written guidance.

Definitions of all key terms are absolutely essential, particularly when they involve commonly used but potentially ambiguous terms (good, many, etc.). Also essential are clear descriptions of the characteristics of various impact types. For example, many sites exhibit at least some evidence for erosion. If a monitoring form requires “erosion” to be marked as present or absent, it is critical to define how much erosion must be observed to be categorized as present. Ideally, the SOP should specify necessary and sufficient conditions to help monitoring personnel make consistent, useful observations.

Routine Monitoring

Several of the important issues relevant to routine monitoring have already been addressed: the need for a well-designed field form, a comprehensive suite of possible adverse impacts, and the need for accurate baseline data. The importance of consistent observations cannot be stressed too much. One way to ensure consistency would be for new monitoring personnel to be trained by experienced monitors (that is, jointly visiting a number of sites). A second practice that would increase consistency would be for site monitoring to occur on a regular basis throughout the year, not as intensive efforts a few times per year. Frequent monitoring would minimize “drift” (variation through time) in how monitoring personnel use relevant terms.

GPS Data

Collecting accurate GPS data should be a component of all baseline and standard monitoring. The SOP should include step-by-step instructions for the particular GPS instrument that will be

used by monitoring personnel. It should include a basic discussion of the factors that contribute to the accuracy of GPS data: instrument grade, number of satellites used, signal-to-noise ratio, and position dilution of precision. Such guidance is readily available on the Internet. Also important is the guidance on how GPS should be used (e.g., how many readings around the perimeter) to delimit the extent of site boundaries, impacted areas, etc.

Photography

Photography provides a solid basis for detecting change in site condition, and can be particularly important for establishing site condition for ARPA cases, etc. Given the importance of photography, it would be wise to include detailed instructions in camera use. The use of predetermined, well-marked photo-points is recommended as a means of ensuring consistency and comparability among photographs taken on successive monitoring visits. Digital photography is strongly recommended because photographs are easy to view in the field, store, and optimize using commercial software. The Monitoring Plan should specify how photographs should be identified and what information aids (e.g., use of a mug board, north arrow and scale in the image, renaming photo files, etc.) are needed. Where the subject of a photograph is an area (such as an area that has eroded), standard markers might be used to mark the edges of the area and the locations of GPS readings.

Recommendations for Treatment

Several of the existing monitoring programs require or allow monitoring personnel to make recommendations for treatment. This practice provides an opportunity to benefit from the first-hand input of individuals who have recently inspected the site. On the other hand, monitoring personnel may or may not have sufficient expertise in treatment options to make proper recommendations. A monitoring strategy needs to note that those who do baseline monitoring need to meet Department of Interior Standards, but those who do subsequent monitoring can have less experience. On balance, formal recommendations for treatment should be made by a qualified archaeologist.

Data Management

Although monitoring per se is not mentioned in the NHPA of 1966, (as amended), its implementing regulations (36 CFR 800), the NAGPRA, or the ARPA of 1979, monitoring is clearly an essential component of an effective cultural resource management program. Identifying an archaeological site and evaluating its eligibility for nomination to the NRHP does not, in and of itself, afford protection to the site. Archaeological sites are vulnerable to adverse impacts from a wide range of natural processes and human actions, and vulnerability can increase as a result of changes in accessibility, land use, vegetation, climate, and many other factors. Section 110 of the NHPA's mandate to protect historic properties clearly requires current, reliable information about changes in site condition.

Given the great range of variability in natural environment, human activities, and site characteristics, it is not feasible to develop a single monitoring strategy that would be appropriate for all situations. This review of existing strategies for monitoring the condition of archaeological sites has provided an empirical basis for identifying best practices for archaeological site monitoring.

Care should be taken to develop a field protocol and monitoring form that elicits essential observations about site condition but minimizes the need to collect information of marginal value. A detailed, written SOP should be developed, and an emphasis should be placed on a consistent use of well-defined terms and categories. An equal emphasis should be placed on the protocol for data management.

Sample Monitoring Forms

Department of Conservation Archaeological Monitoring Form		
Use baseline form and previous visit form for reference Use archaeological form guide for assistance		
Name of Site or Area	NZAA Site Number	
	Site Type	
Location of Site or Area	Metric Grid Reference Easting Northing	
Local Authority	Date:	
Name of Fieldworker(s)	Organization:	
Size of Site (m ²)	Area:	Height:

Indicator	Rating	Estimate (Tick appropriate box)	Notes (location of damage, particular species, etc.)
Current land use		<input type="checkbox"/> Grazing <input type="checkbox"/> Production forestry <input type="checkbox"/> Reserved or other protected public lands <input type="checkbox"/> Cultivation <input type="checkbox"/> Under development <input type="checkbox"/> Residential/commercial/industrial (specify) <input type="checkbox"/> Other (specify)	Specify whether indigenous or exotic species
Current land use adjacent to place or area		<input type="checkbox"/> Same <input type="checkbox"/> Different	
Type of vegetation surrounding place or area		<input type="checkbox"/> Pasture <input type="checkbox"/> Predominantly exotic weed or scrubland <input type="checkbox"/> Exotic or indigenous forest <input type="checkbox"/> No vegetation <input type="checkbox"/> Other (specify)	
Overall assessment of condition	1 2 3 4	<input type="checkbox"/> None or very few signs of disruption to site/area. <input type="checkbox"/> Small signs of disruption to site/area <input type="checkbox"/> Large area of disruption to site/area. <input type="checkbox"/> Site/area almost completely or completely disrupted.	
Extent of loss	1 2 3 4 5	<input type="checkbox"/> Site/area been added to <input type="checkbox"/> Site/area the same size as previous visit <input type="checkbox"/> 20% or less of site/area lost since previous visit. <input type="checkbox"/> 20% or more of site/area lost since previous visit <input type="checkbox"/> Site area completely destroyed or not located	Specify types of development
Speed of deterioration	1 2 3 4	<input type="checkbox"/> No deterioration visible since previous visit. <input type="checkbox"/> Slow, ongoing deterioration visible <input type="checkbox"/> Rapid, ongoing deterioration visible. <input type="checkbox"/> Severe, periodic/one-off deterioration visible.	Specify types of impact
Integrity of site/area	1 2 3 4	<input type="checkbox"/> Not modified or slightly modified (<20% of place or area) <input type="checkbox"/> Partially modified (20-50% of place or area) <input type="checkbox"/> Heavily modified (50-80% of place or area) <input type="checkbox"/> Almost completely destroyed or removed (>80% of place or area)	Specify purpose of and effects of fencing

Indicator	Rating	Estimate (Tick appropriate box)	Notes (location of damage, particular species, etc.)
Extent of vegetation cover over place or area	1 2 3 4	<input type="checkbox"/> Vegetation absent or very uncommon (<10% of place or area) <input type="checkbox"/> Vegetation over 10–20% of place or area <input type="checkbox"/> Vegetation over 20–50% of place or area <input type="checkbox"/> Abundant vegetation over 50% or more of place or area	Specify whether indigenous or exotic species
Effects of erosion or subsidence	1 2 3 4	<input type="checkbox"/> No signs of erosion or subsidence <input type="checkbox"/> Occasional signs of erosion or subsidence (<10% of area) <input type="checkbox"/> Common signs of erosion or subsidence (20–50% of area) <input type="checkbox"/> Abundant or extensive sign (stock on site) of stock/animal damage to site/area	
Effects of stock/animals	1 2 3 4	<input type="checkbox"/> No sign of stock/animal damage to site/area <input type="checkbox"/> Occasional or old sign of stock/animal damage to site/area <input type="checkbox"/> Common or fresh sign of stock/animal damage to site/area <input type="checkbox"/> Abundant or extensive sign (stock on site) of stock/animal damage to site/area	
Disasters	1 2 3 4	<input type="checkbox"/> No sign of any disaster (e.g., fire, landslide, earthquake) <input type="checkbox"/> Sign of an adjacent disaster since last visit to site or area, but site not damaged <input type="checkbox"/> Limited or localized damage to site or area as the result of a disaster since last visit <input type="checkbox"/> Severe or widespread damage to site or area from disaster since last visit	
Effects of Development	1 2 3 4	<input type="checkbox"/> No signs of construction, roading or other development activities <input type="checkbox"/> Occasional, localized signs of construction, roading or other development activities <input type="checkbox"/> Common signs of construction, roading or other development activities, but limited to certain areas. <input type="checkbox"/> Widespread signs of construction, roading or other development activities throughout the area.	Specify types of development
Effects of Visitors	1 2 3 4	<input type="checkbox"/> No signs of visitor impact upon place or area <input type="checkbox"/> Occasional localized signs of trampling, vehicular damage, rubbish, fossicking or other visitor impact <input type="checkbox"/> Common signs of trampling, vehicular damage, rubbish, fossicking or other visitor impact <input type="checkbox"/> Abundant signs of trampling, vehicular damage, rubbish, fossicking or other visitor damage	Specify types of impact
Fencing	1 2 3 4	<input type="checkbox"/> Secure, intact fencing around site <input type="checkbox"/> Most of site fences or secure site fence poorly maintained <input type="checkbox"/> Surrounding area fenced <input type="checkbox"/> No fencing or fencing through site	Specify purpose of and effects of fencing
Effects of Repair Work/ Management	1 2 3 4	<input type="checkbox"/> Repair work or management visible that has improved the condition and integrity of the place or area <input type="checkbox"/> No repair work or management impact visible <input type="checkbox"/> Repair work or management undertaken that has caused limited, localized damage to the place or area <input type="checkbox"/> Repair work or management work undertaken that has caused widespread damage or destroyed place or area	
Other effects upon place or area			Please specify

Recommended management actions	By whom	By when
Have management actions been undertaken as recommended by previous visit?		<input type="checkbox"/> Yes <input type="checkbox"/> No
Any resource consent or NZHPT authority applications concerning place or area since last visit?		<input type="checkbox"/> Yes <input type="checkbox"/> No
Change of ownership since last visit?		<input type="checkbox"/> Yes <input type="checkbox"/> No
Information entered and processed		<input type="checkbox"/> Yes <input type="checkbox"/> No
Date of next visit:		

Photopoint Data		
Number of Photopoints Established	Photographer:	Date Established

Photopoints:		
Photopoint Number	Description of photopoint (i.e. location of photopoint, description of object photo of, whether peg placed at photopoint, rid reference, bearing, distance to object, other reference points, etc.	Film & Photo No.

Sketch plan (include photopoint location and reference points, direction of photo, GPS Point location) and/or additional notes.	

Sample Monitoring Form #1: Archaeological site monitoring form developed for use in New Zealand (from Walton 2003:25-30).

3/00 Grand Canyon National Park and Glen Canyon National Recreation Area
RIVER CORRIDOR ARCHAEOLOGICAL SITE MONITORING FORM

MANAGEMENT

1. Site Number AZ _____
2. Monitor Session _____
3. River Mile _____ Bank (L/R/B) _____
4. Date _____
5. Property Type: _____
6. Monitor(s) _____
7. PA Signatories _____

PHYSICAL IMPACTS

Coding: 0 = Absent, 1 = Active, 2 = Inactive, 3 = NA (for items 8 - 14)

	Structures / Storage	Artifacts	Roasters / Hearths	Perishables / Midden	Rock Images	Other
8. Surface Erosion (0 - 10 cm)						
9. Gullyng (10 - 100 cm)						
10. Arroyo Cuttin (> 1 m)						
11. Bank Slump						
12. Eolian/Alluvial Erosion/Deposition						
13. Side Canyon Erosion						
14. Other Physical Impacts (animals spalling, roots)						

15. Drainage Type (river, terrace, or side canyon-based or no drainages): _____
16. Do any of the above impacts appear to have occurred since the last monitoring episode
 0 = No, 1 = Yes. If yes, explain in Question # 17. _____
17. Comments: _____

3/00 **Grand Canyon National Park and Glen Canyon National Recreation Area**
RIVER CORRIDOR ARCHAEOLOGICAL SITE MONITORING FORM

VISITOR-RELATED IMPACTS

Site Number: _____
 Monitor Session: _____

Coding: 0 = Absent, 1 = Present, 3 = NA (for items 18 - 2)

	Structures / Storage	Artifacts	Roasters / Hearths	Perishables / Midden	Rock Images	Other
18. Visitor Impacts						

19. Collection Piles: If present, explain in Question # 2 _____
20. Trails On-Site: If present, explain in Question # 26. Explain any off-site trails als _____
21. Camping On-Site: If present, explain in Question # 26 _____
22. Criminal vandalism/ARPA violations: If present, explain in Question # 2 _____
23. Other visitor impacts: If present, explain in Question # 2 _____
24. Visitor-related impacts since last monitoring: _____
25. Are any visitor-related impacts directly related to river fluctuations and/or dam operations, i.e. development of new trails to avoid high water, availability of new beaches in proximity of site
 0 = No, 1 = Yes. If yes, explain in Question # 26 _____
26. Comments: _____

RECOMMENDATIONS

27. Monitor Schedule: 1) Discontinue 2) Semiannual 3) Annual 4) Biennial
 5) Every three to five years 6) Inactive 7) Control Group _____
28. Preservation Options: 0 = No, 1 = Yes
 Trail Work _____ Plant vegetation _____ Other Preservation Options _____
 Install checkdams _____
29. Recovery Options: 0 = No, 1 = Yes
 Research _____ Data Recovery _____ Other Recovery Options _____
30. Comments: _____

Sample Monitoring Form #2: Field form used by the Colorado River Corridor Monitoring Program (from Dierker and Leap 2005).

SITE MONITORING FORM

MANAGEMENT:

1. Site Number: _____ 2. Monitor Session: _____ 3. Date: _____
 4. River Mile: RM 5. Bank (E/W/N/S): _____ 6. Access: _____
 7. Site Type/Monitoring Type: _____
 8. Monitor(s): _____ 9. Time to Monitor (hrs/people): _____
 10. Participants: _____

 11. UTM Points to Monitor

Feature Name: _____ m. Easting _____ m. Northing
 Feature Name: _____ m. Easting _____ m. Northing
 Feature Name: _____ m. Easting _____ m. Northing

PHYSICAL IMPACTS:

0 = Absent; 1 = Present; 2 = Increase; 3 = Decrease; 4 = NA (for table items)

Impact Type	Building /Structu res	Artifacts	Hearths / Ovens	Midden/ FCR Layer	House Pit	Other
Surface Erosion (0-10 cm)						
Gullying (10-100 cm)						
Channel Cutting (>1 m)						
Bank Slumpage						
Bank Loss						
Eolian/Alluvial Erosion/Deposition						
Animal Caused Erosion (trails/burrows)						
Other Natural Impacts						

12. If channels or gullies are present, do they drain to the river? (Note: some drainages die out in dune fields or on terraces before reaching the river.) 0 = no; 1 = yes; 2 = NA: _____

13. Do any of the above impacts appear to have occurred since the last monitoring episode? 0 = no; 1 = yes. If yes, explain in Number 14. _____

14. Comments:

Sample Monitoring Form #3: Field form used by the Omaha District Corps monitoring plan (Omaha District 2005).

Dierker, J. L., and L. M. Leap

2005. Archaeological site monitoring and management activities along the Colorado River in Grand Canyon National Park. Report submitted to the U.S. Bureau of Reclamation, Salt Lake City, UT. RCMP Report No. 90, Flagstaff, AZ.

Omaha District

2005. Cultural site monitoring and enforcement plan (draft, April 2005). U.S. Army Corps of Engineers, Omaha District.

U.S. Army Corps of Engineers

2009 Best Practices for Archaeological Site Monitoring. *Public Works Technical Bulletin* No. 200-1-60 (2009), US Army Corps, Washington, D.C.

Walton, T.

2003. *Methods for monitoring the condition of historic places*. Department of Conservation Technical Series 27, Wellington, New Zealand.

**APPENDIX F: VOLUMES – SQUARE, CYLINDER, CONE & TRUNCATED
CYLINDER**
Table Illustrating the Pro’s and Con’s of Using Various Excavation Sized Units

Volumes - Square, Cylinder, Cone & Truncated Cylinder

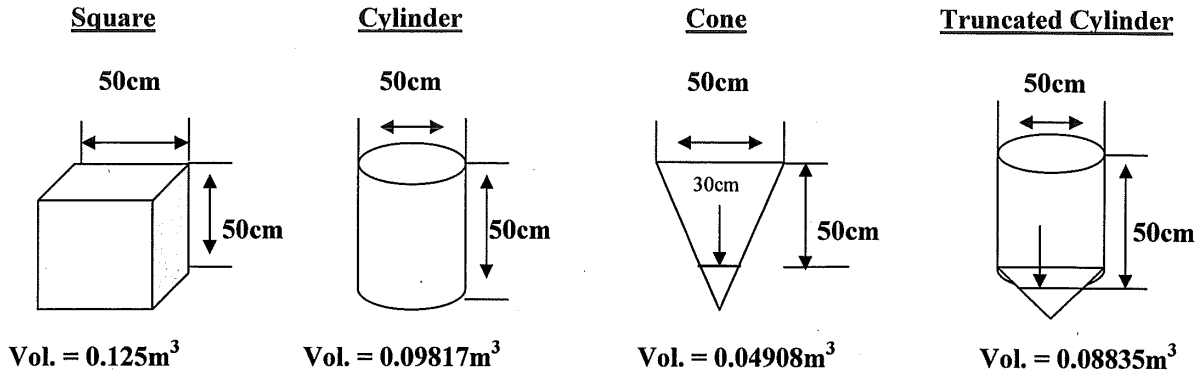

TESTING METHOD	PRO'S	CON'S
Square (Square Shovel)	<ol style="list-style-type: none"> 1. preferred testing method 2. easy to do soil profiles & soil samples 3. integrity of collected data is good 4. able to spot features & intrusions 5. able to provenience artifacts 6. accurate 10cm volume control 7. artifact to soil ratio easy to compute 8. Units are easily photographed & useful 	<ol style="list-style-type: none"> 1. setup & layout longer 2. excavation time moderate 3. moderate technique required
Cylinder (Round Shovel)	<ol style="list-style-type: none"> 1. good for presence/absence testing 2. quick excavation time 3. moderate volume control 4. possible to compute artifact to soil ratio 	<ol style="list-style-type: none"> 1. less preferred testing method 2. 10cm level accuracy difficult 3. soil profiling very difficult 4. photos almost useless 5. temporal mixing of data 6. can't provenience artifacts
Cone (Round Shovel)	<ol style="list-style-type: none"> 1. fair for presence/absence testing 2. quick excavation time 	<ol style="list-style-type: none"> 1. poor testing method 2. 10cm level accuracy impossible 3. soil profiling impossible 4. photos are useless 5. temporal mixing of data 6. skewed data sample 7. bottom of unit worthless 8. poor volume control 9. can't provenience artifacts 10. can't compute artifact to soil ratio
Truncated Cylinder (Round Shovel)	<ol style="list-style-type: none"> 1. good for presence/absence testing 2. quick excavation time 3. moderate volume control 4. possible to compute artifact to soil ratio 	<ol style="list-style-type: none"> 1. less preferred testing method 2. 10cm level accuracy difficult 3. soil profiling very difficult 4. photos almost useless 5. temporal mixing of data 6. can't provenience artifacts 7. bottom of unit worthless

APPENDIX G: GUIDELINES FOR UNDERWATER ARCHAEOLOGY

Underwater Research

Oregon possesses a diverse range of submerged cultural resources, ranging from canoes and pirogues to steamboats, schooners, ocean-going vessels, and aircraft, as well as precontact sites inundated through dam construction and coastal subsidence. These sites receive the same level of protection as do terrestrial sites. In addition to the aforementioned federal laws (e.g., NEPA, NHPA) governing terrestrial site protection and mitigation, additional legislation, such as the Abandoned Shipwreck Act of 1987, serve to further protect these important resources. Oregon state law (ORS 358.905(1)(c)) specifically notes that protection of archaeological sites is not limited to terrestrial environments but extends to submerged and submersible lands and the bed of the sea within the state's jurisdiction.

The following section provides some general guidance to underwater archaeological research in Oregon as well as briefly outlining Phase I, II, and III techniques and guidelines that should assist archaeologists and agency administrators in developing research designs capable of retrieving sufficient amounts of data in order to identify and evaluate submerged cultural resources, primarily sunken vessels. Each phase should be approached within the context of a research design with project results contributing to a better knowledge and understanding of Oregon's past.

General Guidance

1. First and foremost, Oregon does not permit or authorize commercial salvage or removal of artifacts from potentially historic shipwrecks or submerged sites in any form. Doing so is a violation of state law (ORS 358.920). Persons or institutions who apply for a survey or excavation permit on state regulated lands will need to comply with all conditions and requirements established for sites or surveys conducted on land and administered through the SHPO.

A permit is not required to inspect, explore, photograph, or conduct a reconnaissance survey if the use or activity does not: 1) remove any artifacts, 2) involve excavation, destruction, or substantive injury of the historic property or its immediate environment; 3) endanger other persons or property; or 5) violate other regulations or provisions of federal, State, or local law. Any other activities may require a permit.

2. Survey and Excavation Permits may be issued by the SHPO to professional archaeologists for the survey and evaluation of submerged cultural resources in State waters, however, the Principal Investigator (PI) needs to be a professional archaeologist and be suitably qualified as evidenced by training, education, and experience, and possess demonstrable competence in archaeological theory and method, and in collecting, handling, analyzing, evaluating, and reporting marine archaeological data, relative to the type and scope of the work proposed.

Underwater archaeology is very different from terrestrial archaeology. As such, the PI should have: 1) a graduate degree in maritime archaeology, maritime history, or a closely related field, or equivalent training and experience; 2) demonstrated the ability to plan, equip, staff, organize, and supervise the type and scope of activity proposed; 3) have at least 16 months of full-time professional field experience at a supervisory level in the study of historic or prehistoric

maritime archaeological resources, to include at least four months of supervisory field and analytic experience in the specific time period or subject matter of the work proposed; and 4) have demonstrated ability to carry research to completion as evidenced by the timely submission of reports. If the proposed project involves use of diving archaeologists, additional diving certifications are required for diving archaeologists as is project adherence to safety standards such as those developed by the American Academy of Underwater Scientists (AAUS).

3. A project's Area of Potential Effects (APE) should be determined in consultation with the SHPO. Once the APE is determined, a site-specific survey methodology should be developed, in consultation with the SHPO, which focuses on the types of potential resources that may be present.

4. All surveys should utilize techniques including advanced marine remote sensing such as multi-beam sonar, side-scan sonar and/or a magnetometer if appropriate, as well as in-water surveys by qualified archaeologists if feasible. In some cases, remote sensing data acquired for other purposes such as marine habitat mapping may exist and be sufficient to provide enough data to determine the presence or absence of submerged cultural resources.

Each site or survey area will have a unique set of environmental and human factors such as depth, currents, sediments, submerged bottom topography, recorded sites and proximity of past activity that should dictate the type of methodology to be employed. Expected site types will also dictate appropriate methodology. The use of 3-D multi-beam sonar for example, has been highly effective in the Columbia River to search for man-made rock formations and pier foundations, while side scan sonar and magnetometry are more effective for offshore shipwreck searches.

Side-scan sonar is a very effective tool for wide area assessment and is appropriate for large search areas for developing two-dimensional images and evaluation of shadows from features projecting above the seafloor that warrant further investigation. Depending on water depth, high resolution multi beam bathymetric sonar can provide precise three dimensional details and is appropriate for detailed investigations in depths generally less than 300 feet. Deep towed bathymetric sonars or bottom mount scanning bathymetric sonars are beneficial at deeper depths.

Magnetometers and electro magnetic sensors (EM) are beneficial in differentiation of sonar contacts that are ferrous, such as steel hulls and ship anchors or conductive.

In addition to remote sensing, an appropriate underwater survey transect width for diving archaeologists should be determined in consultation with SHPO as well as the method of excavating and number of test units. At a minimum, for shore-based APEs, systematic survey transects should be conducted by two qualified and certified diving archaeologists, with a required safety diver and vessel captain on the support vessel (required minimum personnel).

5. Measured transects should occur across the entire APE, either parallel to the shore or using overlapping controlled arcs from the shore. Any artifacts encountered should be recorded *in situ* and mapped using a buoy and GPS mark, or using bearings and distance to an established underwater datum. Scatters of artifacts and features should also be mapped and recorded to produce an overall site plan. To ground truth or visually inspect potential sites in larger or

deeper areas where remote sensing has located potential resources, use of a Remotely Operated Vehicle (ROV) is an acceptable means of visually identifying objects or features.

6. Methods for subsurface testing can consist of a number of proven methods such as coring, trenching and/or test units using a water suction dredge, or airlift. Evaluating archaeological sites that are underwater, or those sites that may have been inundated following human use and occupation are subject to the same process as those on land. A context and site expectation model needs to be developed and submitted with the permit application. Potential resources discovered will be evaluated based on significance criteria or research questions developed within the site specific context. Each submerged and visible watercraft, as well as other cultural resources (e.g., bridges, structures) identified in the project's area of potential effects, should be recorded and preliminarily evaluated as to its National Register eligibility.

Phase I: Submerged Cultural Resources Survey

The overall goal of a Phase I submerged cultural resources survey is to locate and evaluate resources within the project's area of potential effects. During this phase of research, archaeologists need to recover sufficient information to determine whether further investigations at the site/s are necessary to address National Register eligibility. Specific objectives of the Phase I submerged cultural resources survey include: 1) a review and search of the historical records pertaining to the general project area; 2) a field inspection and complete Phase I survey to determine the presence, nature and degree of integrity, if possible, of remains within the project's area of potential effect; and 3) an evaluation of the potential impact of the project on the identified resources.

Like sites found on land, submerged sites cover a broad spectrum of human activity. In general, they can be grouped into the same two basic categories: Prehistoric (prior to European contact) and Historic Period sites. Prehistoric site types can include: habitation sites, burials, submerged prehistoric features such as fish traps, and even watercraft such as canoes. Historic period submerged sites are most often associated with shipwrecks or intentionally scuttled vessels.

In addition to Oregon's scores of sunken vessels, the scope of the state's submerged cultural resources includes settlement remains, and shoreline facilities associated with all human activities that occurred at the shoreline or on the water. Site types can range from docks, and harbor works to refuse dumped from shoreside settlements. Although less glamorous, these remains help establish a bigger picture of historic events. The tie between shoreside activity and aquatic activity is usually interdependent, and corresponding contexts should take this into consideration.

Modern development poses the primary threat to these resources as, in times past, these locales are commercially and aesthetically preferred.

Guidelines for Offshore Archaeological Field Surveys

Oregon is poised to become a West Coast leader in the development of offshore renewable energy from wind, wave and tidal forces. Some of this development will occur within Oregon's 3-mile jurisdiction. In addition to offshore energy, pipelines, submerged transmission lines and communication lines such as fiber optic cable deployment have the potential to affect submerged resources. To eliminate conflicting standards, and to ensure near shore survey data matches survey data acquired beyond the 3-mile limit, Oregon SHPO is recommending similar requirements for offshore archaeological survey methodology as those required by the federal Bureau of Ocean Energy Management (BOEM - formerly the Minerals Management Service). The guidelines below have been adapted from standards developed by BOEM.

Field surveys generally consist of vessel deployed remote sensing equipment run in a survey pattern with predetermined line spacing depending on the depth of water, type and sensitivity of equipment used. The project APE and line spacing should be determined in consultation with the SHPO. Precise navigation systems are key to being able to relocate and examine submerged targets.

Archaeological Survey Data Acquisition Instrumentation & Recordation

Deployment of remote sensing equipment in an offshore environment is a highly specialized field. Due to varying levels of survey complexity often associated with riverine and marine environments, such as water depths and poor visibility, remote-sensing technologies should be used. Remote-sensing technologies should include, but not be limited to, systematic magnetometer survey, bathymetric or fathometer survey, and side-scan sonar. All instrument data should be recorded in concert with a Differential Global Positioning System (GPS).

Because equipment is often quirky, it is recommended that trained operators familiar with the specific systems to be used conduct these surveys. Although multi-beam sonar has proven effective in many offshore situations, locating older shipwrecks, for example, requires both a magnetometer, side-scan sonar and possibly a subbottom profiler to elucidate the potential for resources. Permittees should consult with the SHPO on the types of remote sensing to be used.

Prior to conducting field surveys, it is recommended that existing databases be consulted. Most of Oregon's coast has been subject to recent remote sensing surveys at varying levels of resolution (detail). Qualified maritime archaeologists can analyze these surveys for potential resources such as shipwrecks. If coverage of your project area is determined adequate by the SHPO, and review of the data does not reveal potentially sensitive areas or shipwrecks, additional fieldwork may not be necessary.

If data does not exist or is insufficient for the APE, the following summarizes equipment and guidelines:

Magnetometer

A magnetometer survey will detect most anomalies in the project's area of potential effects. Archaeologists will need to conduct more detailed systematic magnetic surveys for all anomalies thought to be potentially significant. Analyses of the initial and more detailed magnetic surveys

should provide the principal investigator with enough information to determine the identity of the anomaly and the potential for further testing.

In water depths less than 200 meters (656feet), use a proton precession or cesium total field magnetometer to detect ferrous and other magnetically susceptible metals. Tow the magnetometer sensor as near as possible (but no more than 6 meters (20 feet) above the seafloor) and in a way that minimizes interference from the vessel hull and the other survey instruments.

Attach a depth sensor to the magnetometer sensor and annotate each survey line with tow sensor height off seafloor and with start of the line (SOL) and end of the line (EOL) times. Ensure that magnetometer sensitivity is one gamma (γ) or one nanoTesla (nT) or less, and that the data sampling interval does not exceed one (1) second. Ensure also that the background noise level does not exceed a total of 3 gammas peak to peak.

Record all data in such a way that it can be directly linked to the positioning data. Make sure that the recording scales are set no higher than 1,000-gamma and 100-gamma full scale, respectively. Annotate shot points and recorder speed.

If it is determined that additional testing of an anomaly is needed/required, then side-scan sonar should be employed to enable the principal investigator to make a more precise determination regarding the anomaly's National Register potential. Side-scan sonar may be excluded from use when field conditions prohibit or dictate otherwise. In these instances, a justification for not using side-scan sonar must be discussed in the report. It is important that all generated data (side-scan sonar, magnetometer, etc.) be correlated in order to produce as accurate a survey result as possible.

Dual Channel Side-scan Sonar

Use a towed, dual-channel, dual-frequency, side-scan sonar system to provide continuous planimetric images of the seafloor with sufficient resolution to allow object identification. For archaeological resource surveys in deeper water, we suggest running not more than a 100 meter range for a 200 meter swath. To allow tolerance for the vessel to be off line, we suggest running at 180 meter line spacing when using a 100 meter range to allow for 10 meter off line jogs in either direction.

For archaeological resource surveys at a 50 meter range, run at 80 meter line spacing for 100% coverage. NOAA requires 200% coverage so nadir data is overlapped with good outer range data. 200% coverage is run with 40 meter line spacing at a 50 meter range. Speeds are restricted to allow for 3 pings per meter.

Design the line spacing and display range to ensure at least 100 percent of the proposed survey area in your survey line direction is covered. Tow the side-scan sonar sensor above the seafloor at a distance that is 10 to 20 percent of the range of the instrument. As needed, run extra lines with the side-scan sonar operating at a frequency of 500 kHz or greater for detailed inspection of seafloor contacts. Ensure that the line spacing and display range you use are appropriate for the depth of water.

Display the side-scan sonar data on a graphic recorder capable of adjusting the data for slant-

range effects and variable speed along the line to give a true plan view of the seabed conditions as the survey progresses. Record the data digitally to allow signal processing to improve data quality further and allow export to a workstation for integrated interpretation and mapping of the data. For all right-of-way pipeline/cable surveys, image process and output the recorded data in mosaic form. Output such mosaics as a geo-referenced digital model of the seabed for use in interpretation and reporting. Confidence checks should be documented on both channels at outer ranges during the survey to ensure target detection ability to full range. Features such as drag marks and sediment waves work well for confidence checks.

Subbottom Profiler

Use a very high-frequency subbottom acoustic profiler operating within the 1.5- to 4.5-kHz bandwidth to provide continuous and very high-resolution information of near surface geological features within the uppermost 15 meters (50 feet) of unconsolidated sediment. Run the subbottom profiler system to provide penetration that exceeds the depth of disturbance.

Make sure that the subbottom profiler system is capable of achieving a resolution of vertical bed separation of at least one (1) foot in the uppermost 15 meters (50 feet) below the mud line. Record the data digitally to allow signal processing to improve data quality further and allow export to a workstation for integrated interpretation and mapping of the data.

Depth Sounder

Use a hull mounted, high frequency, narrow beam hydrographic echo sounder to obtain bathymetric data. Display the data on a graphic recorder and log it digitally and continuously. Set up the depth sounder system to record with a sweep appropriate to the range of water depths expected in the survey area. Use a heave compensator in conjunction with the system to remove the effects of vessel movement from the data.

Calibrate water column sound velocity at the start and end of the survey by using a conductivity temperature depth (CTD) sensor or velocity probe capable of recording in the maximum water depth expected in the survey area.

Apply tide correctors to reduce bathymetric data to an appropriate datum such as Mean Lower Low Water.

Remotely Operated Vehicles

If possible, video images of anomalies taken during survey may assist in interpretation of objects detected by the remote sensing equipment.

Survey Navigation

Use a state-of-the-art navigation system that can continuously determine the surface position of the survey vessel. Ensure that the precision of the navigation system is ± 5 meters for surveys in water depths less than 200 meters (656 feet) and ± 15 meters for surveys in water depths 200 meters or greater. Log position fixes digitally at least every 12.5 meters (41 feet) along the vessel track and annotate them on all records at intervals no greater than 152 meters (500 feet).

Show fixes on the final shot point chart at intervals no greater than 152 meters. Use acoustic

positioning of towed sensors for archaeological resource surveys conducted in water depths greater than 91 meters (300 feet) to facilitate sufficiently accurate mapping of any recorded contacts.

Survey Design for Remote Sensing Equipment

For areas that have a high probability for containing historic resources in water depths 200 meters or less, the survey line-spacing interval should be no more than 30 meters. In areas that have a high probability for containing prehistoric archaeological resources, or historic resources in water depths greater than 200 meters (656 feet), the survey line-spacing interval is no more than 300 meters.

Right-of-way Pipeline or Cable Surveys

The survey pattern for all right-of-way pipelines or cables consists of a line run along the proposed pipeline/cable route (centerline), an offset parallel line on one side of the centerline (for 300-meter line spacing surveys only) located approximately 50 meters (152 feet) from the centerline, and a minimum of two additional offset parallel lines (on either side of the centerline) spaced at a maximum of 50 or 300 meters (164 or 984 feet). The number of offset parallel lines must be sufficient to provide coverage of the entire area that could be physically disturbed by pipeline or cable construction activities. The area of physical disturbances includes, but is not limited to the area where pipeline/cable lay barge anchors will be placed.

Positioning Systems

1. A positioning system should be incorporated into all submerged cultural resources surveys, so archaeologists can easily map and relocate any targets encountered. To ensure precision during the remote sensing survey a ± 5 meter variance in positioning data is suggested. In order to achieve this accuracy, the archaeologist should use either an on-shore total station or a Differential (or carrier phase corrected) Global Positioning System (GPS). The on-shore total station may be more practical and feasible if: the survey area is limited in scope, the line of sight between shore and survey vessel is good, and/or there is a single target involved.

Recording of Submerged Features

Systematic water jet probing from the deck of the survey boat or adjacent bank-lines should be conducted to determine the location and extent of all identified submerged watercraft and other potentially significant underwater resources. All exposed watercraft elements should be fully recorded to the extent possible with a detailed discussion provided in the report. Survey and site/s locations must be depicted on 7.5' USGS topographic maps.

Phase II: Submerged Cultural Resource Testing and Evaluation

The primary objective of the Phase II investigation is to determine if the site in question is eligible for inclusion in the National Register of Historic Places (note: Phase I and II underwater investigations are sometimes combined into a single activity. The governing/contracting agency is responsible for ensuring that a scope of work exists in which the specific tasks are outlined and that the proper officials are notified). Unlike terrestrial sites, National Register eligibility for most submerged cultural resources will be determined using most of the established Criterion, as

opposed to just Criterion D (see National Register Bulletin 36). However, as with terrestrial sites, “In order to determine the significance of a site [under Criterion D], enough subsurface investigation must be done to establish the potential for information that can be used to formulate and answer research questions” in regard to a regional context (Bense et al. 1986:56). Investigation objectives include, but are not limited to: 1) the vertical and horizontal extent of intact deposits within each site; 2) the density and distribution of the deposits within each site; 3) the cultural affiliation of the components represented at each site; 4) the presence of undisturbed submerged features or buried stratified deposits at each site; 5) the classes of remains retrievable; and 6) whether the site is eligible for inclusion in the National Register. Phase II investigations should not be initiated without consultation with SHPO.

Supplemental Guidelines for Reports

In addition to meeting the Oregon SHPO requirements for submission of archaeological reports, submerged cultural resources surveys should include enough detail on how the data was acquired to facilitate relocating sites for additional analysis or evaluation. Below are additional guidelines adapted from BOEM to be included in submerged cultural resource reports when appropriate:

Supplemental Contents of Submerged Archaeology Reports

1. A list of the individuals involved in survey planning, fieldwork, and report preparation, and a description of their duties.
2. A discussion of the archaeological resource field survey, including the following:
 - A brief description of the navigation system, including a statement of its estimated accuracy for the area surveyed.
 - A brief description of survey instrumentation, including scale, sensitivity settings, sampling rates, and tow heights off seafloor, as appropriate for each instrument.
 - A description of the survey vessel, including its size, sensor configuration, instrument setbacks, and navigation antennae locations.
 - Vessel speed and course changes.
 - Sea state and weather conditions.
 - A copy of the original daily survey operations log. Include sensor height off seafloor for the magnetometer and side-scan sonar for the beginning and end of each survey line.
 - A description of survey procedures, including a statement of survey and record quality, a comparison of survey line crossings, and discussion of any problem that may affect the ability of the report preparers to determine the potential for archaeological resources in the survey area.
 - An explanation of the problem(s) if you were unable to meet the survey line spacing or instrumentation guidelines.
3. A navigation postplot map of the survey area at a scale of 1:12,000 showing survey lines, shot points at 152-meter (500-foot) intervals, line direction (e.g., UTM, Lambert, or geographic coordinates) with tics placed every five inches thereon, and with geodetic graticules every 60 seconds.

For each copy of the report, submit one hardcopy and two digital copies (one in PDF format and one DWG format) of this map. Orient this map, or separate maps at the same scale that also show survey lines, shot points, and line direction, to true north and delineate the following, as appropriate:

- The horizontal and vertical extent of all relict geomorphic features having potential for associated prehistoric sites. Such areas include, but are not limited to, tidal estuaries, embayments, barrier islands, beach ridge sequences, spits, alluvial terraces, and stream channels.
- When relict fluvial systems are recorded, make sure that the map:
 - Differentiates between generations of channeling when more than one generation is present;
 - Shows any internal channel features such as point bar deposits and terraces;
 - Delineates any channel margin features such as natural levee ridges;
 - Indicates all depths of channel banks and channel axes (thalwegs); and
 - Delineates all areas recommended by your archaeologist for avoidance for potential archaeological resources.
 - Note: An isopach map of channel fill sediments is often the most efficient means of conveying the above information, but this method alone will not allow differentiation between more than one generation of channeling.

4. All magnetic anomalies and seafloor side-scan sonar contacts of unknown source (for magnetic anomalies use map symbol: ▲; for side-scan sonar contacts use map symbol: ☒). Identify these magnetic anomalies and side-scan sonar contacts using only the aforementioned symbols and a unique number keyed to the listings in the unidentified magnetic anomaly and side-scan sonar tables in the text. In congested areas with numerous unidentified magnetic anomalies, you may use a map(s) at a scale of 1:6,000 to depict the anomalies. If you do, tie this congested area map(s) into the 1:12,000 survey area maps. Plot all recommended potential archaeological avoidance areas on the survey area map.

5. Plot all areas of proposed project disturbance.

6. An analysis of the potential for prehistoric sites within the survey area that includes:

- A review of current literature on late Pleistocene and Holocene geology, paleogeography, and sea level change in the area; marine and coastal prehistory; and previous archaeological resource reports in the area, if available.
- A discussion of relict geomorphic features and their archaeological potential that includes the type, age, and association of the mapped features; the acoustic characteristics of channels and their fill material; evidence for preservation or erosion of channel margins; evidence for more than one generation of fluvial downcutting; and the sea level curves you used in the assessment.
- A discussion, based on the capabilities of current technology in relation to the thickness and composition of sediments overlying the area of a potential site, of the potential for identification and evaluation of buried prehistoric sites.

7. All reports should include a current review of existing records for reported shipwreck locations in the survey area and adjacent areas, and the following, as appropriate:

- A table of the unidentified magnetic anomalies within the APE, shot point, and survey line location (corrected for sensor offset); gamma intensity; lateral extent (duration); whether the anomaly is characterized by a dipolar, monopolar, or complex signature; the magnetometer sensor tow height off seafloor; the NAD 27 decimal degree coordinates of the center of each unidentified anomaly; and the recommended avoidance zone.
 - A table of side-scan sonar contacts within the APE, shot point, and survey line location (corrected for sensor offset); size; shape; height of protrusion above the seafloor; the NAD 27 decimal degree coordinates; and recommended avoidance distance of each.
 - A discussion of any magnetic anomalies and side-scan sonar contacts of unknown source in terms of their potential as historic shipwrecks (include an analysis of reported nearby wrecks and their potential association with these contacts on the basis of vessel size and anomaly characterization);
 - A discussion of any correlation between magnetic anomalies or side-scan sonar contacts and known or probable sources;
 - For any archaeological resources that can be positively identified from remote sensing records, an analysis of their possible significance and recommendations for any further research or special precautions that may be necessary;
 - A discussion of the potential for shipwreck preservation in terms of bottom sediment type and thickness, and the effects of past and present marine processes in the survey area; and
 - A discussion of the potential for identification and evaluation of potential shipwrecks considering the capabilities of current technology in relation to the water depth, probable thickness and composition of sediments overlying the potential shipwreck location, and the preservation potential.
8. Be sure to include representative data samples from each survey instrument to demonstrate the quality of the records. If appropriate, include the following data samples, which you may use in lieu of the representative data samples:
- A sample of subbottom profiler data for each type of relict landform that you identify. When more than one generation of fluvial channeling is evident, include a sample that depicts each generation. Make sure that each sample is readable and includes horizontal and vertical scales. If you want to provide any interpretive highlighting or annotation of the sample data, do so on either a separate overlay or a copy of the sample data. Do not highlight original survey data.
 - Copies of all side-scan sonar data where contacts representing unidentified objects are recorded. Make sure that the copies are readable and include the scale. If you want to provide any interpretive highlighting or annotation of the sample side-scan sonar data, do so on either a separate overlay or a copy of the sample data. Do not highlight original survey data. For all right-of-way pipeline surveys, include a digital copy of the computer-generated mosaics as a geo-referenced Tagged Image Format (TIF) file.
9. A summary of conclusions and recommendations supported by the archaeological resource field survey data and archaeological analyses including:
- A discussion of known or potential archaeological resources; and
 - Recommendations for avoidance or for further archaeological investigations.

**APPENDIX H: PROTOCOL FOR COLLECTION OF COPROLITES FOR DNA
ANALYSIS**

Protocol for Collection of Coprolites for DNA Analysis⁸

The recovery of ancient DNA from coprolites requires us to protect the samples from modern DNA contamination. Each of us is a DNA volcano, spewing out vapors and sloughing off cells containing our DNA. Anything we touch or get close to for any period of time is probably contaminated with our DNA. The following protocols must be followed to restrict the amount of this contamination to acceptable levels. Ideally we would all be wearing white suits, face masks, booties, gloves and hoods as we excavate. However, that is not possible under normal field conditions in the Great Basin or other hot and dry locations like the Columbia Plateau due to the heat that these non-permeable clothes generate. Closely following the procedures below is the next best thing.

Collect 4 hairs with roots on from each crew member. If people are concerned about privacy issues you may assign personal identification numbers (PIN) rather than give the person's actual name to the DNA laboratory. Only the Project Director need know the person's name and corresponding PIN. Freeze the hair and send with coprolite samples to DNA lab. This is a tracking measure used only if modern contamination is later detected.

Excavators:

1) Each person will excavate in their assigned unit exclusively, do not change units with your partner or anyone else unless the supervisor approves it. Any variation from this pattern should be clearly noted on your paperwork and in your notebook along with the Unit, quad, and level that the change occurred.

2) When excavating, try to uncover coprolites or other specimens which could be tested for ancient DNA (chewed fibers [quids], menstrual pads, etc.) *in situ*. Do not touch it with your trowel if at all possible. Your trowel is contaminated with your DNA whether you are wearing work gloves or not, because you have handled both the gloves and the trowel. When you identify a coprolite large enough to be human in your excavation stop digging and get away from it immediately, placing your trowel pointing at the coprolite—but not touching it—so that the Coprolite Collector can identify it easily. If you do not recognize something you have found, back off and call in a supervisor. While they are determining what it is write a note that they entered your quad to look at something. If it is a coprolite or something to be collected for DNA analysis you will be the Collector's assistant while they work in your unit.

Coprolite Collector:

1) The Coprolite Collector should carefully put on a pair of latex lab gloves first, trying to avoid touching the fingers and palm as much as possible, then pull on the Tyvek hazmat coveralls. Next, put on your face mask, then cover your head with the hood. The assistant, usually the excavator, rips open the paper container holding the sterile surgeon's gloves and, being careful not to touch the gloves, holds them out to the Collector who removes them—L for left, R for

⁸ Appendix H Protocol by Dr. Dennis Jenkins, University of Oregon Museum of Natural and Cultural History, Eugene.

right—from the sealed packet. Touching only the inside of the sleeves, pull them on carefully over the latex lab gloves. The assistant should then peel back the disposable sterile forceps package exposing the conjoined end for the Collector to grasp and remove from the package. Next, the assistant should carefully peel-back the clear plastic wrapper of a sterile lab cup exposing the top to the Collector who can grasp it with sterile gloved fingers. Avoid touching the cup or breathing on it. It is best for the assistant to wear a face mask to contain their breath.

4) The Collector walks to the specimen careful to avoid raising dust as much as possible, bends and, opening the cup just before, picks up the specimen with the disposable forceps and places it in the cup, closing it immediately thereafter. The Assistant tapes the press-on top shut with masking tape or duct tape and writes all the provenience data on the cup with a Sharpie. Dispose of the forceps and gloves and use new ones for each coprolite collection. Do not put more than one coprolite in a single specimen cup even if there are multiple fragments that look like they could be the same bowel movement. Each gets its own container because you do not know for a fact that they are the same.

5) Next, collect about 1/2 cup of sediment from under the coprolite employing a trowel previously soaked in bleach for 2 minutes. Again, at the end of each collection phase the forceps are contaminated with DNA and should be disposed of. Gloves are thrown away at the end of the collection procedure.

6) Record the precise location and elevation of the *in situ* specimen on your paperwork in the collected specimen column and on the grid area on the paperwork. This must be done for all specimens and each must have a unique number. If you think you may have contaminated the specimen somehow please note what and how the possible contamination occurred.

Screeners:

- 1) If you see a coprolite in the screen stop immediately and carefully set the screen down. You need not suit up since the coprolite may well have already been contaminated. At this stage we simply want to avoid any further contamination if possible.
- 2) Put on a mask, prepare a specimen cup and then, following the procedures noted above, pull on a glove or gloves, pick up the specimen with the disposable forceps and place it in a sample cup. Carefully close and tape the cup as quickly as possible.
- 3) Note on your sample cups the site, unit, quad, level, date, your name, and fact that the coprolite was recovered from the screen. Dispose of the gloves and forceps, they are contaminated.

Materials needed for Sterile Coprolite Collections

- 1) Disposable Paper Tyvek coveralls (large or x large best)
- 2) 125 or 250 ml sterile plastic (see through) specimen cups
- 3) Disposable forceps
- 4) Sterile face masks

- 5) Sterile surgeons gloves (8 or 8.5 most common sizes)
- 6) Purple nitrile lab gloves (medium or large best)

**APPENDIX I: EXAMPLES OF MEMORANDUM OF AGREEMENTS &
PROGRAMMATIC AGREEMENTS**

Examples have been borrowed and modified from the Florida SHPO Guidelines for Use By
Historic Professionals

EXHIBIT A: THREE PARTY MEMORANDUM OF AGREEMENT

**MEMORANDUM OF AGREEMENT
AMONG THE U.S. BUREAU OF BURRO MANAGEMENT,
THE WASHAFORNIA STATE HISTORIC PRESERVATION OFFICE
AND THE
ADVISORY COUNCIL ON HISTORIC PRESERVATION
REGARDING THE SOUTH FIELDSTONE FODDER IMPROVEMENT PROJECT**

WHEREAS the U.S. Bureau of Burro Management (Bureau) proposes to undertake the South Fieldstone Fodder Improvement Project (the Project), described as the preferred alternative on pages 12-17 of the draft Environmental Assessment titled "Draft Environmental Assessment: South Fieldstone Fodder Improvement Project" and dated December 4, 2003 (Draft EA); and

Identifies undertaking subject to review.

WHEREAS the Bureau has established the Project's area of potential effects (APE), as defined at 36 CFR 15 800.16(d), to be the watershed of South Fieldstone Creek as shown in Figure 2B of the Draft EA; and

Identifies APE.

WHEREAS the Bureau has determined that the Project may have adverse effects on archaeological site WFSF342 as described in the Washafornia State Historic Properties Inventory, on Big Rock Ridge, a place of cultural importance to the Motomak Tribe, and possibly to unidentified subsurface archaeological resources; and

Identifies properties known to be subject to adverse effect, with allowance for undiscovered properties.

WHEREAS the Bureau has consulted with the Washafornia State Historic Preservation Office (SHPO), the Motomak Tribe, Burros, Incorporated, the Eastern Washafornia Society, and the Advisory Council on Historic Preservation (Council) in accordance with Section 106 of the National Historic Preservation Act, 16 U.S.C. § (NHPA), and its implementing regulations (36 CFR Part 800.6(b)(2)) to resolve the adverse effects of the Project on historic properties; and

Identifies all consulting parties.

WHEREAS pursuant to 36 CFR 800.6(c)(2) the Bureau has invited the Motomak Tribe and Burros, Incorporated to sign this Memorandum of Agreement (MOA); and

Identifies invited signatory.

WHEREAS pursuant to 36 CFR 800.6(c)(3) the Bureau has invited the Eastern Washafornia Society to concur in this MOA; and

Identifies invited concurring party.

WHEREAS the Bureau intends to use the provisions of this MOA to address applicable requirements of Sections 110(a)(1) and 110(b) of NHPA; and

Use only where MOA actually will be used to address such requirements. Adapt as needed regarding other NHPA requirements or the requirements of other cultural resource laws, but document how each other law is satisfied separately from the MOA, to avoid implying that the ACHP or SHPO are involving themselves in matters beyond their authorities under Section 106.

WHEREAS the Bureau has coordinated preparation of this MOA with development of its Plan of Action under the Native American Graves Protection and Repatriation Act (NAGPRA) in accordance with 43 CFR 10;

Use only where NAGPRA applies, and where coordination has occurred (as it should). Make sure the Plan of Action (POA) is a separate document developed by the agency and tribe(s), but that it is consistent with the terms of the MOA and vice-versa.

NOW, THEREFORE, the Bureau, the SHPO, and the Council agree that upon the Bureau's decision to proceed with the Project, the Bureau shall ensure that the following stipulations are implemented in order to take into account the effects of the Project on historic properties, and that these stipulations shall govern the Project and all of its parts until this MOA expires or is terminated.

Note that this clause is conditioned upon the agency's decision to proceed with whatever it is considering vis-à-vis the undertaking (constructing it, implementing it, permitting it, assisting it, etc.). This is to make it clear that the consulting parties are not pre-empting the agency's final decision on the project under other pertinent authorities, including the National Environmental Policy Act (NEPA). Note that it also includes the language of NHPA Section 110(l), specifying the "governing" (contractual) authority of the MOA.

Stipulations

The Bureau shall ensure that the following stipulations are implemented:

(Insert stipulations. Always include a "sunset" stipulation)

Execution of this MOA by the Bureau, the SHPO, and the Council, and implementation of its terms, evidence that the Bureau has afforded the Council an opportunity to comment on the Project and its effects on historic properties, and that the Bureau has taken into account the effects of the Project on historic properties.

This ultimate clause is the assertion of the signatories that the agency has -- assuming it carries out the terms of the MOA -- complied with the two requirements of Section 106: to take into account the effects of the undertaking on historic properties, and to afford the Council a reasonable opportunity to comment.

BUREAU OF BURRO MANAGEMENT

By: _____ Date: _____

WASHAFORNIA STATE HISTORIC PRESERVATION OFFICE

By: _____ Date: _____

MOTOMAK TRIBE

By: _____ Date: _____

ADVISORY COUNCIL ON HISTORIC PRESERVATION

By: _____ Date: _____

CONCUR:

EASTERN WASHAFORNIA SOCIETY

By: _____ Date: _____

EXHIBIT B: TWO PARTY MEMORANDUM OF AGREEMENT

MEMORANDUM OF AGREEMENT BETWEEN THE U.S. GOVERNMENT SERVICES BUREAU AND THE MOTOMAK TRIBAL HISTORIC PRESERVATION OFFICE REGARDING THE BIG BROWN BANK REHABILITATION AND REUSE PROJECT

WHEREAS the U.S. Government Services Bureau (GSB) proposes to rehabilitate the Big Brown Bank Building at 75-25 East Peltier Street, Town of Motomak, in accordance with the documents entitled "Conceptual Plans for Big Brown Bank Rehabilitation" dated October 7, 2003 (the Undertaking); and

Identifies undertaking subject to review. For purposes of the example, assume that the Town of Motomak is within the boundaries of the Motomak Reservation, and the Motomak THPO has assumed the SHPO's responsibilities under 36 CFR 800.

WHEREAS GSB has established the Undertaking's area of potential effects (APE), as defined at 36 CFR 15 800.16(d), to be the Big Brown Bank Building itself, together with the streetscapes on Peltier, Banks, and Means Streets and the buildings facing the Big Brown Bank Building across all three of the above-named streets; and

Identifies APE.

WHEREAS GSB has determined that the Undertaking may have adverse effects on the Big Brown Bank Building and on the Deloria District as described in the report entitled "Historic Properties Survey, Big Brown Bank Rehabilitation Project", prepared by Architrave Associates and dated December 4, 2003, which GSB and the Motomak Tribal Historic Preservation Officer (THPO) have agreed meets the criteria for inclusion in the National Register of Historic Places, and possibly on archaeological resources lying beneath the Big Brown Bank Building and the surrounding streets; and

Identifies properties known to be subject to adverse effect, with allowance for undiscovered properties.

WHEREAS GSB has consulted with the Motomak THPO, the Town of Motomak, and the Washafornia Chapter of the American Institute of Architects (AIA) in accordance with Section 106 of the National Historic Preservation Act, 16 U.S.C. § 470 (NHPA), and its implementing regulations (36 CFR Part 800.6(b)(1)) to resolve the adverse effects of the Project on historic properties; and

Identifies all consulting parties.

WHEREAS pursuant to 36 CFR 800.6(c)(2) GSB has invited the Town of Motomak to sign this Memorandum of Agreement (MOA); and

Identifies invited signatory.

WHEREAS pursuant to 36 CFR 800.6(c)(3) GSB has invited the AIA to concur in this MOA; and

Identifies invited concurring party.

WHEREAS GSB intends to use the provisions of this MOA to address applicable requirements of Sections 110(b) and 111 of NHPA; and

Use only where MOA actually will be used to address such requirements. Adapt as needed regarding other NHPA requirements or the requirements of other cultural resource laws, but document how each other law is satisfied separately from the MOA, to avoid implying that the ACHP or THPO are involving themselves in matters beyond their authorities under Section 106.

WHEREAS GSB has coordinated preparation of this MOA with development of its Plan of Action under the Native American Graves Protection and Repatriation Act (NAGPRA) in accordance with 43 CFR 10;

Use only where NAGPRA applies, and where coordination has occurred (as it should). Make sure the Plan of Action (POA) is a separate document developed by the agency and tribe(s), but that it is consistent with the terms of the MOA and vice-versa.

NOW, THEREFORE, GSB and the THPO agree that upon GSB's decision to proceed with the Undertaking, GSB shall ensure that the following stipulations are implemented in order to take into account the effects of the Project on historic properties, and that these stipulations shall govern the Project and all of its parts until this MOA expires or is terminated.

Note that this clause is conditioned upon the agency's decision to proceed with whatever it is considering vis-à-vis the undertaking (constructing it, implementing it, permitting it, assisting it, etc.). This is to make it clear that the consulting parties are not pre-empting the agency's final decision on the project under other pertinent authorities, including the National Environmental Policy Act (NEPA). Note that it also includes the language of NHPA Section 110(l), specifying the "governing" (contractual) authority of the MOA.

Stipulations

GSB shall ensure that the following stipulations are implemented:

(Insert stipulations. Always include a "sunset" stipulation)

Execution of this MOA by GSB and the THPO, and its submission to the Advisory Council on Historic Preservation (Council) in accordance with 36 CFR 800.6(b)(1)(iv), shall, pursuant to 36

CFR 800.6(c), be considered to be an agreement with the Council for the purposes of Section 110(l) of NHPA. Execution and submission of this MOA, and implementation of its terms evidence that GSB has afforded the Council an opportunity to comment on the Project and its effects on historic properties, and that GSB has taken into account the effects of the Project on historic properties.

Note that this ultimate clause is a little different from the one used where the Council participates in consultation, reflecting the language of the regulations with regard to this kind of MOA.

GOVERNMENT SERVICES BUREAU

By:_____ Date:_____

MOTOMAK TRIBAL HISTORIC PRESERVATION OFFICER

By:_____ Date:_____

TOWN OF MOTOMAK

By:_____ Date:_____

CONCUR:

WASHAFORNIA CHAPTER, AMERICAN INSTITUTE OF
ARCHITECTS

By:_____ Date:_____

EXHIBIT C: PROGRAMMATIC AGREEMENT

PROGRAMMATIC AGREEMENT AMONG

THE [NAME OF AGENCY],
THE ADVISORY COUNCIL ON HISTORIC PRESERVATION,
[AND] **THE [designate SHPO, SHPOs, THPOs; National Conference of SHPOs; National Conference of THPOs; other parties] REGARDING IMPLEMENTATION OF THE [identify program, etc.]**

WHEREAS, the [name of agency] proposes to administer the [name of program or project] authorized by [cite statutory authority]; and

WHEREAS, the [name of agency] has determined that the [program/project] may have an effect upon properties included in or eligible for inclusion in the National Register of Historic Places and has consulted with the Advisory Council on Historic Preservation (Council) and the [Oregon State Historic Preservation Officer (SHPO)/National Conference of State Historic Preservation Officers (NCSHPO)/others] pursuant to Section 800.14 of the regulations (36 CFR Part 800) implementing Section 106 of the National Historic Preservation Act; (16 U.S.C. 470f), [and Section 110(f) of the same Act (16 U.S.C. 470h-2(f)); and

WHEREAS, [names of other consulting party/parties, if any] participated in the consultation and [has/have] been invited to [execute/concur in] this Programmatic Agreement; and

WHEREAS, the definitions given in Appendix ___ are applicable throughout this Programmatic Agreement;

NOW, THEREFORE, [name of agency], the Council, and the [SHPO/NCSHPO/other] agree that the [program/project] shall be administered in accordance with the following stipulations to satisfy [name of agency]'s Section 106 responsibility for all individual [undertakings of the program/aspects of the program].

Stipulations

[Name of agency] will ensure that the following measures are carried out:

[Insert stipulations here.]

() The Council and the [SHPO/NCSHPO/other] may monitor activities carried out pursuant to this Programmatic Agreement, and the Council will review such activities if so requested .The [name of agency] will cooperate with the Council and the [SHPO/NCSHPO/other] in carrying out their monitoring and review responsibilities.

() *Any party to this Programmatic Agreement may request that it be amended, whereupon the parties will consult in accordance with 36 CFR 800.13 to consider such amendment.*

() *Any party to this Programmatic Agreement may terminate it by providing thirty (30) days notice to the other parties, provided that the parties will consult during the period prior to termination to seek agreement on amendments or other actions that would avoid termination. In the event of termination, the [name of agency] will comply with 36 CFR 800.4 through 800.6 with regard to individual undertakings covered by this Programmatic Agreement.*

() *In the event the [name of agency] does not carry out the terms of this Programmatic Agreement, the [name of agency] will comply with 36 CFR 800.4 through 800.6 with regard to individual undertakings covered by this Programmatic Agreement.*

Execution and implementation of this Programmatic Agreement evidences that [name of agency] has satisfied its Section 106 responsibilities for all individual undertakings of the program.

ADVISORY COUNCIL ON HISTORIC PRESERVATION

By: _____ Date: _____
(Name and title of signer)

[NAME OF AGENCY]

By: _____ Date: _____
(Name and title of signer)

OREGON STATE HISTORIC PRESERVATION OFFICER

By: _____ Date: _____
(Name and title of signer)

[OTHER SIGNATORIES, IF ANY]