

The following is a summary of significant changes in the 2021 Oregon Residential Specialty Code (ORSC) from the previous edition. The 2021 ORSC is based on the 2018 International Residential Code (IRC). This summary is intended to help with the transition from the previous edition and does not include all changes adopted in the 2021 ORSC.

Part I of this summary is a matrix identifying the sections with significant changes and a summary of each change. Part II is the code language for each of the sections included in Part I as it will appear in the 2021 ORSC.

## Part I – Summary Matrix

Section	Topic / Summary of change
<b>R101.2</b>	<b>Application of the 2021 ORSC.</b> Updated Chapter 1 to accurately reflect scoping policy, delegated authority, local allowances and applicable construction standards.
<b>R102.7.2</b>	<b>Repairs.</b> Clarified requirements for existing buildings; provisions specific to repairs have been separated from the alteration and addition provisions.
<b>R105.1.1</b>	<b>New spaces.</b> Added clarifying language for building permit requirements for new habitable spaces, new toilet rooms, or new bathrooms.
<b>R105.2</b>	<b>Work exempt from permit.</b> Updated this section to clarify the application and scope of this code, and the popular detached one story nonhabitable accessory structure exemption height threshold has been adjusted for alignment purposes.
<b>R106.1</b>	<b>Submittal documents.</b> Updated language regarding the design of “exempt structures” and the associated construction document requirements.
<b>R301.1.3</b>	<b>Engineered design.</b> Added new language that properly identifies the associated design values where the prescriptive code is exceeded, and where a design in accordance with accepted engineering practice is provided. This is not a technical change.
<b>R301.2</b>	<b>Climatic and geographic design criteria.</b> Updated and revised the wind, snow and seismic provisions throughout Chapter 3 in alignment with the Oregon Structural Specialty Code (OSSC) and to provide a more streamlined approach to load determinations.  Updated the Oregon-specific Table R301.2(1) to incorporate those revisions.
<b>R301.2.1</b>	<b>Wind design criteria.</b> Replaced the Oregon-specific design wind speed map, Figure R301.2.1, with an Oregon special wind regions map that is based on the latest data (ASCE 7-16). These revisions align with the OSSC.

Section	Topic / Summary of change
<b>R301.2.1</b>	<p><b>Wind design – component and cladding.</b></p> <p>Adopted model code provisions for component and cladding provisions and the following:</p> <ul style="list-style-type: none"> <li>• Table R301.2.1(1) <i>Component and Cladding Loads for a Building with a Mean Roof Height of 30 Feet Located in Exposure B</i></li> <li>• Table R301.2.1(2) <i>Height and Exposure Adjustment Coefficients for Table R301.2.1(1)</i></li> <li>• Figure R301.2.1(1) <i>Component and Cladding Pressure Zones</i></li> </ul>
<b>R301.2.2</b>	<p><b>Determination of seismic design category (SDC).</b></p> <p>Adopted model code site-specific seismic design criteria provisions and amended only for clarity and to streamline the approach. The values are based on the National Seismic Hazard Model (NSHM) maps.</p>
<b>R301.2.2.6</b>	<p><b>Irregular buildings.</b></p> <p>Added new figures to help illustrate the various irregularities that require design in accordance with accepted engineering practice. This is not a technical change.</p>
<b>R301.2.3</b>	<p><b>Snow loads.</b></p> <p>Updated snow load provisions to reflect a more accurate path for obtaining site-specific ground snow loads. This compliance path refers to the Oregon State University / Structural Engineer’s Association of Oregon online lookup mapping tool. <a href="http://Snowload.seao.org/lookup.html">Snowload.seao.org/lookup.html</a></p>
<b>R302.1</b>	<p><b>Exterior walls. (fire separation distance)</b></p> <p>Added the following clarifications for the application of Section R302.1:</p> <ul style="list-style-type: none"> <li>• Added a clarification for the minimum fire separation distance where multiple detached dwellings are permitted by land-use to be on a single lot.</li> <li>• Added a clarification that all attached decks, other than those exempted by Section R105.2, are considered projections and shall comply with Table R302.1. This clarification has also been added as footnote c to Table R302.1.</li> <li>• Added clarification that fireblocking needs to be at least two-layers of two-inch nominal lumber.</li> </ul>
<b>R302.2</b>	<p><b>Townhouses.</b></p> <p>Updated the Oregon-specific townhouse provisions and figures for clarity and reintroduced the longstanding townhouse utility separation provisions.</p>
<b>R302.3.2</b>	<p><b>Two-family dwellings.</b></p> <p>Added new language to provide compliance options where a two-family dwelling is separated by a real property line.</p>
<b>R303.4</b>	<p><b>Mechanical ventilation.</b></p> <p>Adopted model code language and revised to require that <b>all</b> dwelling units be provided with whole-house ventilation.</p>
<b>R310.1</b>	<p><b>Emergency escape and rescue opening required.</b></p> <p>Adopted new model code allowances where the dwelling or townhouse is equipped with an automatic sprinkler system and other conditions are met.</p>
<b>R310.2.5</b>	<p><b>Emergency escape and rescue openings above lower roof surfaces.</b></p> <p>Added provisions for a path on roof surfaces located below emergency escape and rescue openings intended to avoid obstructions that could hinder escape and rescue.</p>
<b>R310.2.6</b>	<p><b>Replacement windows.</b></p> <p>Adopted new model code provisions exempting replacement windows from the requirements of Section R310.2.1, Minimum opening area, and Section R310.2.2, Window sill height, where specific conditions are met. This aligns with Statewide Code Interpretation 92-01, Replacement of Existing Glazing.</p>

Section	Topic / Summary of change
<b>R310.3.2</b>	<p><b>Area wells.</b></p> <p>Adopted new model code provisions replacing the terminology for “bulkhead enclosures” to “area wells” and adding provisions for ladders and steps for area wells.</p>
<b>R311.7</b>	<p><b>Stairways.</b></p> <p>Added new language to clarify that all stairways serving the dwelling (deck/porch stairways) are intended to comply with the R311 requirements and not just those serving as an element of the egress system.</p>
<b>R311.8</b>	<p><b>Ramps.</b></p> <p>Added new language to clarify that all ramps serving the dwelling (deck/porch stairways) are intended to comply with the R311 requirements and not just those serving as an element of the egress system.</p>
<b>R312.2.1</b>	<p><b>Window sills.</b></p> <p>Added provisions to specify that, for the application purposes of the “greater than 72 inches” vertical distance threshold, the surface other than grade must be flat and must provide not less than 36 inches in width to qualify as a measuring point.</p>
<b>R318.1</b>	<p><b>Vapor retarders.</b></p> <p>Added allowances to use Class III vapor retarders for framed walls where vented cladding is installed over wood structural panels or continuous air impermeable insulation is applied on exterior above-grade wall surfaces.</p>
<b>R324</b>	<p><b>Solar energy systems.</b></p> <p>Adopted the model code solar energy system installation provisions and modified the amendment path to Chapter 23 of the ORSC and Section 3111 of the OSSC. Also aligns with the provisions for allowances of building integrated photovoltaic (BIPV) components and photovoltaic shingles in Chapter 9.</p>
<b>R326</b>	<p><b>Habitable attic.</b></p> <p>Added new provisions establishing habitable attic criteria, introducing additional design flexibility for “attic storage truss” designs without consideration of additional story.</p>
<b>R329</b>	<p><b>Swimming pools, spas and hot tubs / Oregon Appendix G.</b></p> <p>Adopted the model code swimming pools, spas, and hot tub provisions referencing the International Swimming Pool and Spa Code (ISPSC) and rescinded the former Oregon Appendix G.</p> <p>The ISPSC provides an updated national approach to pools and hot tubs, including flexible design allowances to consider and is available for free viewing online through ICC.</p>
<b>R403.1</b>	<p><b>Footings.</b></p> <p>Retained and updated the simplified Table R403.1, <i>Minimum width of concrete, precast or masonry footings</i>, with the 2012 IRC values and included values for 1,000 pounds per square foot soil bearing based on interpolation.</p>
<b>R404.1.2</b>	<p><b>Foundation walls reinforcement.</b></p> <p>Retained and integrated existing clarifications to the minimum reinforcement requirements for stem walls located in Seismic Design Categories B and C.</p>
<b>R408.3</b>	<p><b>Unvented crawl space.</b></p> <p>Retained the Oregon-specific unvented crawl space provisions for counties subject to mandatory radon mitigation and added a new option for a building official to approve continuous mechanical exhaust systems designed to operate in parallel with mandatory radon mitigation.</p>

Section	Topic / Summary of change
<b>R507</b>	<p><b>Decks.</b></p> <p>Adopted new model code provisions expanding on permissible materials, required footings, and deck posts. Also, new language was added to incorporate deck guard requirements from the guard provisions of R312 of Chapter 3. <a href="#">See American Wood Council’s Design for Code Acceptance (DCA) 6.</a></p>
<b>R602.9</b>	<p><b>Cripple walls.</b></p> <p>Added language to establish a differentiation between interior cripple walls used to support floor systems, and exterior cripple walls constructed on continuous exterior footing/stemwalls.</p>
<b>R602.10.1.2</b>	<p><b>Wall bracing offsets.</b></p> <p>Added language to clarify the requirements where all the braced wall panels along a braced wall line occur within a single line.</p>
<b>R602.10.1.4</b>	<p><b>Mixing wall bracing methods.</b></p> <p>Moved the provisions allowing mixing of intermittent bracing and continuous sheathing methods to its own item for clarity.</p>
<b>R602.10.4.4</b>	<p><b>Braced wall panel joints.</b></p> <p>Adopted new model code language clarifying that blocking at all horizontal panel joints for a continuously sheathed structure is not required, it’s only required at the qualifying/designated braced wall panels.</p>
<b>R703.1.1</b>	<p><b>Exterior wall envelope.</b></p> <p>Retained the Oregon amendments for creating a drainage plane and added a clarification for the available exceptions.</p>
<b>R905.16/17</b>	<p><b>Photovoltaic (PV) shingles and building integrated photovoltaic (BIPV) panels.</b></p> <p>Adopted new model code provisions that address PV shingles and BIPV panels. This newer technology is becoming more common in residential construction.</p>
<b>R908.3.1</b>	<p><b>Roof recover (Reroofing).</b></p> <p>Rescinded the existing amendment allowing three layers of roofing to be installed on an existing dwelling. Adopted the model code requirement that allows for only two layers.</p>
<b>N1101.1</b>	<p><b>Scope and additional measures.</b></p> <ul style="list-style-type: none"> <li>• Revised to require that all conditioned spaces within residential buildings comply with Table N1101.1(1) and <b>one</b> additional measure from Table N1101.1(2).</li> <li>• Reduced the required fenestration <i>U</i>-factor in Table N1101.1(1) from <i>U</i>-0.30 to <i>U</i>-0.27.</li> <li>• Revised Table N1101.1(2) into eight additional measures to choose for compliance.</li> </ul>
<b>N1101.3</b>	<p><b>Large and small additions.</b></p> <ul style="list-style-type: none"> <li>• Revised to clarify the difference between large and small additions by removing the reference to a percent of the existing building heated floor area.</li> <li>• Increased the small addition exception to represent a 15 ft. x 15 ft. room addition.</li> <li>• Aligned Table N1101.3 with the associated changes and deleted the path for ductwork sealing.</li> </ul>
<b>N1104.5</b>	<p><b>Advanced and intermediate framing.</b></p> <p>Revised Sections N1104.5.1 and N1104.5.2 to specify R-10 insulation for voids in headers 2 inches or greater.</p>

Section	Topic / Summary of change
<b>N1104.8</b>	<p><b>Air sealing requirements.</b></p> <ul style="list-style-type: none"> <li>• Revised Section N1104.8.1 to incorporate the former additional measure #5 into the prescriptive language, so, a continuous air barrier is required.</li> <li>• Revised Section N1104.8.2 to require that top plates be sealed or that the dwelling be tested to demonstrate a blower door result not less than 4.0 ACH50</li> <li>• Added a new Table N1104.8 to align the requirements.</li> </ul>
<b>N1105.2</b>	<p><b>N1105.2 Insulation of ducts.</b></p> <ul style="list-style-type: none"> <li>• Revised to require that HVAC ducts be located inside the thermal envelope.</li> <li>• Added an exception for ductwork buried deep within insulation. Up to 5% of total duct length may be located outside envelope.</li> </ul>
<b>N1105.3</b>	<p><b>Installation of ducts.</b></p> <p>Added a section requiring all new duct systems and air handling equipment and appliances to be located fully within the building thermal envelope.</p>
<b>N1105.6</b>	<p><b>Ventilation fan efficiency.</b></p> <p>Revised to require that intake fans, in addition to exhaust fans, be Energy Star certified.</p>
<b>N1105.7</b>	<p><b>Furnace fan efficiency.</b></p> <p>Added language requiring that new furnaces have electrically commutated motors meeting federal efficiency standards.</p>
<b>N1106.2</b>	<p><b>Service hot water pipe insulation.</b></p> <p>Added language requiring that the first 8 feet of pipe into and out of the water heater be insulated.</p>
<b>N1107</b>	<p><b>High-efficiency lighting sources.</b></p> <ul style="list-style-type: none"> <li>• Added language establishing new lumens per watt levels and requiring that the two fixture exceptions be on a dimmer or automatic control.</li> <li>• Also, revised the definition of high-efficiency lighting sources using the technical definition approved for 2021 IECC/IRC.</li> </ul>
<b>N1107.4</b>	<p><b>Solar-ready provisions</b></p> <p>Retained the solar-ready provision amendments adopted in October 2020.</p>
<b>M1307.3.1</b>	<p><b>Impact protection.</b></p> <p>Replaced Figure M1307.3.1 with a more detailed figure.</p>
<b>M1502.4.2</b>	<p><b>Duct installation.</b></p> <ul style="list-style-type: none"> <li>• Retained the existing amendment requiring support in 4 foot or fewer intervals.</li> <li>• Added provisions that require exhaust duct joints be sealed with listed tape.</li> <li>• Adopted new model code provisions requiring enough space to ensure that dryer exhaust ducts enclosed in a wall or a ceiling space are not deformed.</li> </ul>
<b>M1503.1/2</b>	<p><b>Domestic cooking equipment.</b></p> <p>Adopted new model code provisions requiring domestic cooking exhaust equipment to comply with four options.</p>
<b>M1503.3</b>	<p><b>Exhaust discharge.</b></p> <p>Added an exception allowance for listed recirculating hoods where continuous mechanical exhaust of 20 cfm or more is provided, and a natural ventilation opening is provided.</p>

Section	Topic / Summary of change
M1503.6.2	<p><b>Makeup air dampers.</b></p> <p>Adopted new model code requirements for makeup air dampers to be a gravity damper or an electrically operated damper that automatically opens when the exhaust system operates. Dampers shall also be located to allow access.</p>
M1505.4.1	<p><b>Whole-house mechanical ventilation.</b></p> <p>Added provisions in Section M1505.4.1 requiring that the whole-house mechanical ventilation system required by Section R303.4 provide balanced ventilation. See the new Chapter 2 definition for whole-house-mechanical ventilation and balanced ventilation.</p>
M1505.6	<p><b>Rooms with water closets, bathing facilities, or spa facilities.</b></p> <p>Retained the existing amendments for rooms with water closets, bathing facilities or spa facilities and revised them to require a mechanical ventilation system controlled by a dehumidistat, timer or similar means of automatic control.</p>
M1601.4.1	<p><b>Joints, seams, and connections.</b></p> <p>Revised to clarify that tape shall not be used to seal metal ductwork except under limited conditions.</p>
M1601.4.11	<p><b>Ductwork installation location.</b></p> <p>Added a new section requiring that supply and return ductwork be installed within the thermal envelope in accordance with Chapter 11, including the exception for ductwork deeply buried in insulation.</p>
M2301	<p><b>Solar thermal energy systems.</b></p> <p>Adopted new model code requirements for access to equipment and protection from freezing.</p>
M2427.5.10	<p><b>Insulation shield.</b></p> <p>Adopted new model code requiring that insulation shields be installed for factory-built chimneys. This new language matches the existing language for vents.</p>
Appendix F	<p><b>Radon control methods.</b></p> <p>New language and figures have been added to clarify the longstanding intent. The building tightness crawlspace path has been deleted due to superseding requirements.</p>

## PART II – SIGNIFICANT CHANGES CODE LANGUAGE

The text formatting represents the following:

- Blue/Underlined = New Oregon amendment
- Blue = Existing Oregon amendment
- Red = New model code language



# CHAPTER 1 SCOPE AND ADMINISTRATION

## Scope.

**R101.2 Scope.** The *Oregon Residential Specialty Code*, as adopted by the State of Oregon, Building Codes Division, includes portions of the *International Residential Code* and the *International Fire Code* pertaining to any construction, reconstruction, alteration, repair and installation of materials and equipment in or part of buildings and structures covered under the *state building code*.

**R101.2.1 Application.** The provisions of this code shall apply to the construction, *alteration*, movement, enlargement, replacement, *repair, equipment*, use, occupancy and location of the following:

1. Detached one- and two-family *dwellings* and *townhouses* classified as Group R-3, not more than three stories above *grade plane* in height, and their *accessory structures*.
2. Detached owner-occupied *lodging houses* containing not more than five guest rooms.
3. Residential aircraft hangars as defined in Section R202.
4. Live/work units located in detached one- and two-family *dwellings* and *townhouses* and complying with the requirements of Section 419 of the *Building Code*.

The following uses shall comply with the *Building Code*:

1. New “family childcare” uses and new “foster care” uses identified in ORS Chapters 418, 443 and 329A, located within detached one-family *dwellings*, shall be classified as Group R-3 occupancies.
2. Congregate living facilities.

Consistent with discretionary decision-making powers granted to *building officials*, a *building official* may take any action including but not limited to waiving a requirement, modifying a requirement and/or accepting an alternate method to the requirements of the *state building code*. When waiving or accepting a modification, a *building official* shall not allow a provision that would create an unsafe or dangerous condition regarding fire and life safety, and may not enforce requirements that are in addition to the *state building code* except where additional code requirements are specified by the terms of an alternate method approval.

**R101.2.2 Optional local adoption.** In addition to the work exempt from *building permit* in Section R105, the following items are exempt from *building permits* unless specifically required by a *municipality's* local ordinance. If a *municipality* adopts an ordinance to require a *permit* for any of these items, the construction standards of this code shall be applicable:

1. Fences, other than required *swimming pool* barriers, constructed of wood, wire mesh or chain link. Statewide, fences serving as a *swimming pool* barrier, or as a portion of a *swimming pool* barrier, shall require a *building permit*. A *municipality* may adopt an ordinance to regulate the construction of other fences constructed of wood, wire mesh or chain link, provided that the threshold established for requiring a *building permit*

does not include fences that are 7 feet (2134 mm) or less in height. A *municipality* may adopt an ordinance to regulate fences constructed of materials other than wood, wire mesh or chain link, regardless of height. A local height threshold greater than 7 feet (2134 mm) is allowed, regardless of which materials are used.

2. Retaining walls. Statewide, retaining walls that provide safeguards for the users of the buildings, support a regulated building or retain material that, if not restrained, could impact a regulated building shall require a *building permit*. A *municipality* may adopt an ordinance to regulate other retaining walls, provided that the threshold established for requiring a *permit* does not include retaining walls 4 feet (1219 mm) or less in height, when measured from the bottom of the footing to the top of the wall except where the retaining wall supports ascending slope exceeding 3:1 or where the retaining wall supports a nonsoil surcharge. A local height threshold greater than 4 feet (1219 mm) is allowed.
3. Freestanding radio television and other telecommunication antennae and towers not attached to or supported by a regulated building. A local *municipality* may adopt an ordinance to require a *building permit* for these structures.
4. Ground-mounted photovoltaic systems. A local *municipality* may adopt an ordinance to require a *building permit* for these structures, provided that a *permit* is not required for these structures that are 10 feet (3048 mm) or less in height, measured to the highest point of the installation, provided that no public access is permitted beneath the structures. A local height threshold greater than 10 feet (3048 mm) is allowed.
5. Tanks that are located exterior to and not attached to or supported by a regulated building.
6. Fixed docks not supporting a superstructure.
7. The design and construction of in-ground *swimming pools* accessory to detached one- and two-family *dwellings*, and individual *townhouse dwelling units*.

## Repairs.

**R102.7 Existing structures.** The legal occupancy of any structure existing on the date of adoption of this code shall be permitted to continue without change, except as is specifically covered in this code.

**R102.7.1 Additions and alterations.** *Additions and alterations* to any structure shall conform to the requirements for a new structure without requiring the existing structure to comply with the requirements of this code, unless otherwise stated. *Additions* and *alterations* shall not cause an existing structure to become unsafe or adversely affect the performance of the building.

An unsafe condition shall be deemed to have been created if an addition or alteration will cause the existing building or structure to become structurally unsafe or overloaded; will not

provide adequate egress in compliance with the provisions of this code or will obstruct existing egress; will create a fire hazard; will reduce required fire resistance; or will otherwise create conditions dangerous to human life. Any building plus new additions shall not exceed the height and stories specified for new buildings in Section R101.2.

**Exception:** Structural changes which improve the resistance of the building to seismic forces may be made without complying with the current code requirements provided that:

1. The strength of the existing structural elements is not reduced; and
2. An unsafe condition is not created.

**R102.7.2 Repairs.** Repairs shall not make the building any less conforming with the provisions of this code than the building was before the repair was undertaken. Repairs for the purposes of building maintenance shall comply with Section R105.2.2. Repairs for the purposes of correcting damage shall be permitted to conform with the code edition in effect at the time of original construction, where the requirements of this section are met.

Where it becomes necessary to repair all or a portion of a legally existing building that has been damaged by, including but not limited to fire, wind, flood, earthquake or other similar damage, and where prior to the damage the legally existing building did not contain unsafe conditions, the building may be reconstructed exactly as it existed prior to the damage. The following requirements from the currently effective code shall be included in the reconstruction, where applicable:

1. Repaired structural elements in accordance with the design criteria and loading requirements of Chapter 3, or to the maximum extent practical as approved by the building official.
2. Smoke alarms in accordance with Section R314.
3. Carbon monoxide alarms in accordance with Section R315.
4. Guards and fall protection in accordance with Section R312.
5. Hazardous glazing locations in accordance with Section R308.
6. Emergency escape and rescue openings in accordance with Section R310.
7. Table N1101.2, to the maximum extent practical.
8. Floodplain construction requirements, where applicable, as determined by the flood plain administrator.

Such repairs for the purposes of correcting damage are not required to meet other current code requirements for new construction. Where unsafe conditions existed prior to the damage occurring, the building may be reconstructed in accordance with this section provided that the unsafe conditions are corrected, as determined by the building official.

## New spaces

**R105.1.1 New spaces.** The creation of new *habitable spaces*, new toilet rooms, or new bathrooms shall require a building permit.

## Work exempt from permit.

**R105.2 Work exempt from permit.** Exemption from *permit* requirements of this code shall not be deemed to grant authorization for any work to be done in any manner in violation of the provisions of this code or any other laws. Nothing in this code limits a local municipality's ability to require application of its ordinances, or to enforce its own ordinances. See Section R101 for the application and scope of this code. Permits shall not be required for the following:

### Building:

1. Nonhabitable one-story detached *accessory structures*, provided that the floor area does not exceed 200 square feet (18.58 m<sup>2</sup>) and does not exceed a height of 15 feet (4572 mm) measured from grade plane to the average height of the highest roof surface.

**Exception:** Where the structure is located on a parcel of 2.0 acres or greater in area, and the structure is located a minimum of 20 feet (6096 mm) from all property lines and regulated structures, the floor area may be increased to 400 square feet (37.16 m<sup>2</sup>).

2. Concrete sidewalks, slabs, platforms, driveways and similar work.
3. Painting, papering, tiling, carpeting, cabinets, counter tops, interior wall, floor or ceiling covering, shelving and similar work.
4. Above-grade and on-ground swimming pools.
5. Swings, other playground equipment and similar work.
6. Patio covers, as defined in Section AH102, and porch covers not over 200 square feet (11 m<sup>2</sup>) and supported by an exterior building wall.
7. Window awnings supported by an exterior wall that do not project more than 54 inches (1372 mm) from the exterior wall and do not require additional support.
8. Nonbearing partitions, except when such partitions create *habitable space*.
9. Replacement or repair of siding not required to be fire resistive.
10. Retrofitted insulation.
11. Masonry repair.
12. Porches and decks where the floor or deck is not more than 30 inches (762 mm) above adjacent *grade* measured at any point within 3 feet (914 mm) horizontally of the floor or deck, and where in the case of a covered porch the covered portion of the porch does not come closer than 3 feet (914 mm) to *lot* lines.
13. Gutters and downspouts.
14. Door and window replacements (where no structural member is changed).
15. Re-roofing, where replacement or repair of roofing and sheathing does not exceed 30 percent of the required live load design capacity.

**Exceptions:** Permits for re-roofing are required for the following:

1. Structures in wildfire hazard zones as provided in Section R327.
2. Townhouses.
3. Installation of building-integrated photovoltaic roof panels or other photovoltaic roof coverings.



16. Framed-covered nonhabitable *accessory structures* not more than 500 square feet (46.45 m<sup>2</sup>) in area, one story in height and not closer than 3 feet (914 mm) to a property line, where the structure is composed of a rigid framework that supports a fabric membrane.

Unless otherwise exempted, separate plumbing, electrical and mechanical *permits* may be required for the above exempted items.

**Electrical:** See the *Electrical Code*.

**Mechanical:**

1. Portable heating *appliances*, cooking or clothes drying appliances.
2. Portable ventilation *appliances*.
3. Portable cooling units.
4. Steam, hot- or chilled-water piping within any heating or cooling *equipment* regulated by this code.
5. Replacement of any minor part that does not alter approval of *equipment* or make such *equipment* unsafe.
6. Portable evaporative coolers.
7. Self-contained refrigeration systems containing 10 pounds (4.54 kg) or less of refrigerant or that are actuated by motors of 1 horsepower (746 W) or less.
8. Portable-fuel-cell *appliances* that are not connected to a fixed piping system and are not interconnected to a power grid.

**Plumbing:** See the *Plumbing Code*.

2.3. Alterations or repairs that do not involve structural parts of the building.

## Submittal documents.

**R106.1 Submittal documents.** Submittal documents consisting of *construction documents*, and other data shall be submitted in two or more sets with each application for a *permit*. The *construction documents* shall be prepared by a registered *design professional* where required by state law. Where special conditions exist, the *building official* is authorized to require additional *construction documents* to be prepared by a registered *design professional*.

**Exception:**

1. The *building official* is authorized to waive the submission of *construction documents* and other data not required to be prepared by a registered *design professional* if it is found that the nature of the work applied for is such that reviewing of *construction documents* is not necessary to obtain compliance with this code.
2. Plans, calculations, specifications, diagrams and other data prepared and designed by an architect or an engineer licensed by the state to practice as such are not required for the following work:
  - 2.1. The erection, enlargement or alteration of any building, or any appurtenance thereto, where the resulting building has a ground area of 4,000 square feet (372 m<sup>2</sup>) or less and is not more than 20 feet (6096 mm) in height from the top surface of the lowest floor to the highest interior overhead finish (ORS 671.030).
  - 2.2. A detached single-family dwelling, a farm agricultural building, nonfarm agricultural building, or accessory building to a single-family dwelling.

## CHAPTER 2 DEFINITIONS

**ACCESS (TO).** That which enables a device, an appliance or equipment to be reached by ready access or by a means that first requires the removal or movement of a panel, door or similar obstruction.

**ATTIC, HABITABLE.** A finished or unfinished habitable space within an attic.

**BALANCED VENTILATION.** Any combination of concurrently operating mechanical exhaust and mechanical supply whereby the total mechanical exhaust airflow rate is within 10 percent of the total mechanical supply airflow rate.

**BATTERY SYSTEM, STATIONARY STORAGE.** A rechargeable energy storage system consisting of electrochemical storage batteries, battery chargers, controls and associated electrical *equipment* designed to provide electrical power to a building. The system is typically used to provide standby or emergency power, an uninterruptible power supply, load shedding, load sharing or similar capabilities.

**BUILDING-INTEGRATED PHOTOVOLTAIC PRODUCT.** A building product that incorporates photovoltaic modules and functions as a component of the building envelope.

**BUILDING-INTEGRATED PHOTOVOLTAIC ROOF PANEL (BIPV Roof Panel).** A *photovoltaic panel* that functions as a component of the building envelope.

**CARBON MONOXIDE ALARM.** A single- or multiple-station alarm intended to detect carbon monoxide gas and alert occupants by a distinct audible signal. It incorporates a sensor, control components and an alarm notification appliance in a single unit.

**CARBON MONOXIDE DETECTOR.** A device with an integral sensor to detect carbon monoxide gas and transmit an alarm signal to a connected alarm control unit.

**CHANGE OF OCCUPANCY.** A change in the use of a building or portion of a building that involves a change in the application of the requirements of this code.

**COLLAPSIBLE SOILS.** Soils that exhibit volumetric reduction in response to partial or full wetting under load.

**COMPRESSIBLE SOILS.** Soils that exhibit volumetric reduction in response to the application of load even in the absence of wetting or drying.

**CONGREGATE LIVING FACILITIES.** These facilities will be in accordance with the Building Code. See Chapter 1, Scope of application.

**CRAWL SPACE.** An underfloor space that is not a basement.

**DECK, ATTACHED.** An exterior floor system supported on at least one side by the exterior wall of the adjoining structure and supported on the opposing side by posts, piers or other support methods.

**DECK, DETACHED.** An exterior floor system not anchored to a structure and is provided with its own independent support system.

**EXPANSIVE SOILS.** Soils that exhibit volumetric increase or decrease (swelling or shrinking) in response to partial or full wetting or drying under load.

**FENESTRATION.** Products classified as either vertical fenestration or skylights and sloped glazing, installed in such a manner as to preserve the weather-resistant barrier of the wall or roof in which they are installed. Fenestration includes products with glass or other transparent or translucent materials.

**FENESTRATION, VERTICAL.** Windows that are fixed or movable, opaque doors, glazed doors, glazed block and combination opaque and glazed doors installed in a wall at less than 15 degrees from vertical.

**GABLE.** The triangular portion of a wall beneath the end of a dual-slope, pitched, or mono-slope roof or portion thereof and above the top plates of the story or level of the ceiling below.

**GROUND SNOW LOAD, *p<sub>g</sub>*.** The site-specific weight of the accumulated snow at the ground level. It generally has a 50-year mean recurrence interval.

**HEIGHT, STORY.** For the topmost story, the vertical distance measured along the exterior face of exterior wall at the tallest roof eave, from the top of the floor finish to the top of the ceiling joists, or where there are no ceiling joists (vaulted ceiling) to the top of the roof rafters. For stories below the topmost story, the vertical distance from top to top of finished floor surfaces.

**HISTORIC BUILDING.** A building or structure that is one or more of the following:

1. Listed, or certified as eligible for listing, by the State Historic Preservation Officer or the Keeper of the National Register of Historic Places in the National Register of Historic Places.
2. Designated as historic under an applicable state or local law.
3. Certified as a contributing resource within a National Register-listed, or a state-designated or locally designated historic district.

**IMPACT PROTECTIVE SYSTEM.** Construction that has been shown by testing to withstand the impact of test missiles and that is applied, attached, or locked over exterior glazing.

**LOCKING-TYPE TAMPER-RESISTANT CAP.** A cap designed to be unlocked by a specially designed tool or key to prevent removal of the cap by means of hand-loosening or by commonly available tools.

**LODGING HOUSE.** A detached one-family dwelling where one or more occupants are primarily permanent in nature, and containing not more than five guest rooms, where rent is paid in money, goods, labor or otherwise. The total number of guests shall not exceed 16. Lodging houses include “bed and breakfast” and similar use.

**ROOF ASSEMBLY.** A system designed to provide weather protection and resistance to design loads. The system consists of a roof covering and roof deck or a single component serving as both the roof covering and the roof deck. A roof assembly includes the roof deck, *underlayment and roof covering*, and can also include a thermal barrier, ignition barrier, insulation or a vapor retarder.

**ROOF COATING.** A fluid-applied, adhered coating used for roof maintenance or *roof repair*, or as a component of a *roof covering system* or *roof assembly*.

**SOLAR ENERGY SYSTEM.** A system that converts solar radiation to usable energy, including *photovoltaic panel systems* and *solar thermal systems*.

**SOLAR THERMAL COLLECTOR.** Components in a *solar thermal system* that collect and convert solar radiation to thermal energy.

**SWIMMING POOL.** Any structure intended for swimming or recreational bathing that contains water over 24 inches (610 mm) deep. This includes in-ground, above-ground and on-ground swimming pools, hot tubs and spas.

**VAPOR RETARDER.** A vapor-resistant material, membrane or covering such as foil, plastic sheeting, or insulation that limits the amount of moisture vapor that passes through a material.

**WHOLE-HOUSE MECHANICAL VENTILATION SYSTEM.** A combination of supply fan systems and exhaust fan systems designed to mechanically exchange indoor air for outdoor air where operating continuously or through a programmed intermittent schedule to provide a balanced ventilation system that satisfies the whole-house ventilation requirements of Chapter 15.

**WIND SPEED,  $V$ .** Basic design wind speeds.

**WIND SPEED,  $V_{asd}$ .** Allowable stress design wind speeds.

# CHAPTER 3 BUILDING PLANNING

## Engineered design criteria.

**R301.1.3 Engineered design.** Where a building of otherwise conventional construction contains structural elements exceeding the limits of Section R301 or otherwise not conforming to this code, these elements shall be designed in accordance with accepted engineering practice. The extent of such design need only demonstrate compliance of nonconventional elements with other applicable provisions and shall be compatible with the performance of the conventional framed system. Engineered design in accordance with the *Building Code* is permitted. Where a design, in accordance with accepted engineering practice, is provided for a structure, or portion thereof, the design values and limitations of Sections R301.5, R301.6, and R301.7 shall apply. All other structural design requirements shall be in accordance with Chapter 16 of the *Building Code*, as applicable.

## Climatic and geographic design criteria.

**R301.2 Climatic and geographic design criteria.** Buildings shall be constructed in accordance with the provisions of this code as limited by the provisions of this section. Additional criteria shall be as set forth in Table R301.2(1).

**R301.2.1 Wind design criteria.** Buildings and portions thereof shall be constructed in accordance with the wind provisions of this code using the basic design wind speed,  $V$ , in Table R301.2(1). Where different construction methods and structural materials are used for various portions of a building, the applicable requirements of this section for each portion shall apply. Where not otherwise specified, the wind loads listed in Table R301.2.1(1) adjusted for height and exposure using Table R301.2.1(2) shall be used to determine design load performance requirements for wall coverings, curtain walls, roof coverings, exterior windows, skylights, garage doors and exterior doors. Asphalt shingles shall be designed for wind speeds in accordance with Section R905.2.4. A continuous load path shall be provided to transmit the applicable uplift forces in Section R802.11.1 from the roof assembly to the foundation.

**R301.2.1.2 Wind speed conversion.** Where referenced documents are based on allowable stress design wind speeds,  $V_{asd}$ , and do not provide the means for conversion between basic design wind speeds,  $V$ , and allowable stress design wind speeds,  $V_{asd}$ , the basic design wind speeds,  $V$ , shall be converted to allowable stress design wind speeds,  $V_{asd}$ , using Table R301.2.1.2.

TABLE R301.2.1.2  
WIND SPEED CONVERSIONS<sup>a</sup>

$V$ (mph)	90	95	100	105	110	115	120	125	130	135
$V_{asd}$	70	74	77	81	85	89	93	97	101	105

For SI: 1 mile per hour = 0.447 m/s.  
a. Linear interpolation is permitted.

**R301.2.1.3 Exposure category.** For each wind direction considered, an exposure category that adequately reflects the characteristics of ground surface irregularities shall be determined for the site at which the building or structure is to be constructed. For a site located in the transition zone between categories, the category resulting in the largest wind forces shall apply. Account shall be taken of variations in ground surface roughness that arise from natural topography and vegetation as well as from constructed features.

**R301.2.1.3.1 Wind directions and sectors.** For each selected wind direction at which the wind loads are to be evaluated, the exposure of the building or structure shall be determined for the two upwind sectors extending 45 degrees (0.79 rad) either side of the selected wind direction. The exposures in these two sectors shall be determined in accordance with Sections R301.2.1.3.2 and R301.2.1.3.3 and the exposure resulting in the highest wind loads shall be used to represent winds from that direction.

**R301.2.1.3.2 Surface roughness categories.** A ground surface roughness within each 45-degree (0.79 rad) sector shall be determined for a distance upwind of the site as defined in Section R301.2.1.3.3 from the following categories, for the purpose of assigning an exposure category as defined in Section R301.2.1.3.3.

**Surface Roughness B.** Urban and suburban areas, wooded areas or other terrain with numerous closely spaced obstructions having the size of single-family dwellings or larger.

**Surface Roughness C.** Open terrain with scattered obstructions having heights generally less than 30 feet (9144 mm). This category includes flat open country, and grasslands.

**Surface Roughness D.** Flat, unobstructed areas and water surfaces. This category includes smooth mud flats, salt flats and unbroken ice.

**R301.2.1.3.3 Exposure Categories.** An exposure category shall be determined in accordance with the following:

**Exposure B.** Exposure B shall apply where the ground surface roughness, as defined by Surface Roughness B, prevails in the upwind direction for a distance of not less than 1,500 feet (457 m).

**Exposure C.** Exposure C shall apply for all cases where Exposure B or D does not apply.

**Exposure D.** Exposure D shall apply where the ground surface roughness, as defined by Surface Roughness D, prevails in the upwind direction for a distance of not less than 5,000 feet (1524 m) or 20 times the height of the building, whichever is greater. Exposure D shall apply where the ground surface roughness immediately upwind of the site is B or C, and the site is within a distance of 600 feet (183 m) or 20 times the building height, whichever is greater, from an Exposure D condition as defined in the previous sentence.

**TABLE R301.2(1)  
CLIMATIC AND GEOGRAPHIC DESIGN CRITERIA<sup>1, a</sup>**

COUNTY	GROUND SNOW LOAD, $p_g$	BASIC DESIGN WIND SPEED, $V$ (mph) <sup>b</sup>	SPECIAL WIND REGION BASIC DESIGN WIND SPEED, $V$ (mph) <sup>b</sup>	SEISMIC DESIGN CATEGORY	SUBJECT TO DAMAGE			AIR FREEZING INDEX
					Weathering <sup>d</sup>	Frost line depth (inches)	Decay	
Baker	<a href="#">Note a</a>	103	-	Note c	Severe	24	Slight	<u>2,000</u>
Benton	<a href="#">Note a</a>	96	-	Note c	Moderate	12	Moderate	<u>&lt; 1,500</u>
Clackamas	<a href="#">Note a</a>	98	<u>120</u>	Note c	Moderate	12	Moderate	<u>&lt; 1,500</u>
Clatsop	<a href="#">Note a</a>	97	<u>135</u>	Note c	Moderate	12	Moderate	<u>&lt; 1,500</u>
Columbia	<a href="#">Note a</a>	97	<u>120</u>	Note c	Moderate	12	Moderate	<u>&lt; 1,500</u>
Coos	<a href="#">Note a</a>	95	<u>120<sup>h</sup></u>	Note c	Moderate	12	Moderate	<u>&lt; 1,500</u>
Crook	<a href="#">Note a</a>	98	<u>110</u>	Note c	Severe	18	Slight	<u>2,000</u>
Curry	<a href="#">Note a</a>	95	<u>135</u>	Note c	Moderate	12	Moderate	<u>&lt; 1,500</u>
Deschutes	<a href="#">Note a</a>	98	<u>110</u>	Note c	Severe	18	Slight	<u>&lt; 1,500</u>
Douglas	<a href="#">Note a</a>	97	<u>120<sup>h</sup></u>	Note c	Moderate	18	Moderate	<u>&lt; 1,500</u>
Gilliam	<a href="#">Note a</a>	<u>100<sup>j</sup></u>	-	Note c	Severe	24	Moderate	<u>&lt; 1,500</u>
Grant	<a href="#">Note a</a>	101	-	Note c	Severe	24	Slight	<u>2,000</u>
Harney	<a href="#">Note a</a>	101	-	Note c	Severe	24	Moderate	<u>2,000</u>
Hood River	<a href="#">Note a</a>	<u>98<sup>i</sup></u>	-	Note c	Severe	24	Moderate	<u>&lt; 1,500</u>
N.45.5°N	-	-	<u>120<sup>i</sup></u>	-	-	-	-	-
S.45.5°N	-	-	<u>110</u>	-	-	-	-	-
Jackson	<a href="#">Note a</a>	96	-	Note c	Moderate	18 <sup>e</sup>	Slight	<u>&lt; 1,500</u>
Jefferson	<a href="#">Note a</a>	99	<u>110</u>	Note c	Severe	18	Moderate	<u>&lt; 1,500</u>
Josephine	<a href="#">Note a</a>	95	-	Note c	Moderate	18 <sup>e</sup>	Moderate	<u>&lt; 1,500</u>
Klamath	<a href="#">Note a</a>	98	<u>120</u>	Note c	Severe	24	Moderate	<u>&lt; 1,500</u>
Lake	<a href="#">Note a</a>	99	-	Note c	Severe	24	Slight	<u>&lt; 1,500</u>
Lane	<a href="#">Note a</a>	98	<u>120<sup>h</sup></u>	Note c	Moderate	12	Moderate	<u>&lt; 1,500</u>
Lincoln	<a href="#">Note a</a>	96	<u>135</u>	Note c	Moderate	12	Moderate	<u>&lt; 1,500</u>
Linn	<a href="#">Note a</a>	98	-	Note c	Moderate	12	Moderate	<u>&lt; 1,500</u>
Malheur	<a href="#">Note a</a>	102	-	Note c	Severe	24	Slight	<u>&lt; 1,500</u>
Marion	<a href="#">Note a</a>	98	-	Note c	Moderate	12	Moderate	<u>&lt; 1,500</u>
Morrow	<a href="#">Note a</a>	101 <sup>i</sup>	-	Note c	Severe	24	Slight	<u>&lt; 1,500</u>
Multnomah	<a href="#">Note a</a>	98 <sup>i</sup>	<u>120<sup>j</sup></u>	Note c	Moderate	<u>18<sup>e</sup></u>	Moderate	<u>&lt; 1,500</u>
Polk	<a href="#">Note a</a>	97	-	Note c	Moderate	12	Moderate	<u>&lt; 1,500</u>
Sherman	<a href="#">Note a</a>	99 <sup>j</sup>	-	Note c	Severe	24	Slight	<u>&lt; 1,500</u>
Tillamook	<a href="#">Note a</a>	96	<u>135</u>	Note c	Moderate	12	Moderate	<u>&lt; 1,500</u>
Umatilla	<a href="#">Note a</a>	102 <sup>i</sup>	-	Note c	Severe	24	Slight	<u>&lt; 1,500</u>
Union	<a href="#">Note a</a>	102	-	Note c	Severe	24	Slight	<u>&lt; 1,500</u>
Wallowa	<a href="#">Note a</a>	103	-	Note c	Severe	24	Slight	<u>&lt; 1,500</u>
Wasco	<a href="#">Note a</a>	99	<u>110<sup>j</sup></u>	Note c	Severe	24	Slight	<u>&lt; 1,500</u>
Washington	<a href="#">Note a</a>	97	-	Note c	Moderate	12	Moderate	<u>&lt; 1,500</u>
Wheeler	<a href="#">Note a</a>	100	-	Note c	Severe	24	Slight	<u>&lt; 1,500</u>
Yamhill	<a href="#">Note a</a>	97	-	Note c	Moderate	12	Moderate	<u>&lt; 1,500</u>

For SI: 1 inch = 25.4 mm

- a. The ground snow load,  $p_g$  shall be determined in accordance with Section R301.2.3.1.
- b. Sites located within a special wind region as determined from Figure R301.2.1 shall use the special wind region basic design wind speeds provided herein.
- c. The seismic design category shall be determined in accordance with Section R301.2.2.1.
- d. A “severe” classification is where weather conditions result in significant snowfall combined with extended periods during which there is little or no natural thawing, causing de-icing salts to be used extensively.
- e. The frost line depth below 2,500 feet in Jackson, Josephine and Multnomah Counties is 12 inches.
- f. See Sections R301.2.4 and R322 for flood plain administrator determinations and flood hazard design criteria.
- g. See Section R327 for establishment of wildfire hazard mitigation design criteria.
- h. The basic design wind speed,  $V$ , for buildings and structures in this region with full exposure (wind Exposure Category D) to Pacific Ocean winds shall 135 mph.
- i. The basic design wind speed,  $V$ , for buildings and structures in this region with full exposure (wind Exposure Category D) to Columbia River Gorge winds shall be 135 mph.
- j. The basic design wind speed,  $V$ , for buildings and structures in this region with full exposure (wind Exposure Category D) to Columbia River Gorge winds shall be 120 mph.

**TABLE R301.2.1(1)**  
**COMPONENT AND CLADDING LOADS FOR A BUILDING WITH**  
**A MEAN ROOF HEIGHT OF 30 FEET LOCATED IN EXPOSURE B (ASD) (psf)<sup>a, b, c, d, e</sup>**

	ZONE	EFFECTIVE WIND AREA (feet <sup>2</sup> )	BASIC WIND SPEED, V (mph)									
			110		115		120		130		135	
Roof 0 to 7 degrees	1	10	10.0	-13.0	10.0	-14.0	10.0	-15.0	10.0	-18.0	<u>10.0</u>	<u>-19.5</u>
	1	20	10.0	-12.0	10.0	-13.0	10.0	-15.0	10.0	-17.0	<u>10.0</u>	<u>-18.5</u>
	1	50	10.0	-12.0	10.0	-13.0	10.0	-14.0	10.0	-17.0	<u>10.0</u>	<u>-18.0</u>
	1	100	10.0	-11.0	10.0	-13.0	10.0	-14.0	10.0	-16.0	<u>10.0</u>	<u>-17.5</u>
	2	10	10.0	-21.0	10.0	-23.0	10.0	-26.0	10.0	-30.0	<u>10.0</u>	<u>-32.5</u>
	2	20	10.0	-19.0	10.0	-21.0	10.0	-23.0	10.0	-27.0	<u>10.0</u>	<u>-29.0</u>
	2	50	10.0	-16.0	10.0	-18.0	10.0	-19.0	10.0	-23.0	<u>10.0</u>	<u>-24.5</u>
	2	100	10.0	-14.0	10.0	-15.0	10.0	-16.0	10.0	-19.0	<u>10.0</u>	<u>-20.5</u>
	3	10	10.0	-33.0	10.0	-36.0	10.0	-39.0	10.0	-46.0	<u>10.0</u>	<u>-49.5</u>
	3	20	10.0	-27.0	10.0	-29.0	10.0	-32.0	10.0	-38.0	<u>10.0</u>	<u>-41.0</u>
	3	50	10.0	-19.0	10.0	-21.0	10.0	-23.0	10.0	-27.0	<u>10.0</u>	<u>-29.5</u>
	3	100	10.0	-14.0	10.0	-15.0	10.0	-16.0	10.0	-19.0	<u>10.0</u>	<u>-20.5</u>
Roof > 7 to 27 degrees	1	10	10.0	-11.0	10.0	-13.0	10.0	-14.0	10.5	-16.0	<u>11.4</u>	<u>-17.5</u>
	1	20	10.0	-11.0	10.0	-12.0	10.0	-13.0	10.0	-16.0	<u>10.6</u>	<u>-17.0</u>
	1	50	10.0	-11.0	10.0	-12.0	10.0	-13.0	10.0	-15.0	<u>10.0</u>	<u>-16.5</u>
	1	100	10.0	-10.0	10.0	-11.0	10.0	-12.0	10.0	-15.0	<u>10.0</u>	<u>-16.0</u>
	2	10	10.0	-20.0	10.0	-22.0	10.0	-24.0	10.5	-29.0	<u>11.4</u>	<u>-31.0</u>
	2	20	10.0	-19.0	10.0	-20.0	10.0	-22.0	10.0	-26.0	<u>10.6</u>	<u>-28.5</u>
	2	50	10.0	-16.0	10.0	-18.0	10.0	-20.0	10.0	-23.0	<u>10.0</u>	<u>-25.0</u>
	2	100	10.0	-15.0	10.0	-16.0	10.0	-18.0	10.0	-21.0	<u>10.0</u>	<u>-22.5</u>
	3	10	10.0	-30.0	10.0	-33.0	10.0	-36.0	10.5	-43.0	<u>11.4</u>	<u>-46.0</u>
	3	20	10.0	-28.0	10.0	-31.0	10.0	-34.0	10.0	-40.0	<u>10.6</u>	<u>-43.0</u>
	3	50	10.0	-26.0	10.0	-28.0	10.0	-31.0	10.0	-36.0	<u>10.0</u>	<u>-39.0</u>
	3	100	10.0	-24.0	10.0	-26.0	10.0	-28.0	10.0	-33.0	<u>10.0</u>	<u>-36.0</u>
Roof > 27 to 45 degrees	1	10	11.9	-13.0	13.1	-14.0	14.2	-15.0	16.7	-18.0	<u>18.1</u>	<u>-19.5</u>
	1	20	11.6	-12.0	12.7	-13.0	13.8	-14.0	16.2	-17.0	<u>17.5</u>	<u>-18.5</u>
	1	50	11.2	-11.0	12.2	-12.0	13.3	-13.0	15.6	-16.0	<u>16.9</u>	<u>-17.0</u>
	1	100	10.9	-10.0	11.9	-11.0	12.9	-12.0	15.1	-15.0	<u>16.4</u>	<u>-16.0</u>
	2	10	11.9	-15.0	13.1	-16.0	14.2	-18.0	16.7	-21.0	<u>18.1</u>	<u>-22.5</u>
	2	20	11.6	-14.0	12.7	-16.0	13.8	-17.0	16.2	-20.0	<u>17.5</u>	<u>-21.5</u>
	2	50	11.2	-13.0	12.2	-15.0	13.3	-16.0	15.6	-19.0	<u>16.9</u>	<u>-20.5</u>
	2	100	10.9	-13.0	11.9	-14.0	12.9	-15.0	15.1	-18.0	<u>16.4</u>	<u>-19.5</u>
	3	10	11.9	-15.0	13.1	-16.0	14.2	-18.0	16.7	-21.0	<u>18.1</u>	<u>-22.5</u>
	3	20	11.6	-14.0	12.7	-16.0	13.8	-17.0	16.2	-20.0	<u>17.5</u>	<u>-21.5</u>
	3	50	11.2	-13.0	12.2	-15.0	13.3	-16.0	15.6	-19.0	<u>16.9</u>	<u>-20.5</u>
	3	100	10.9	-13.0	11.9	-14.0	12.9	-15.0	15.1	-18.0	<u>16.4</u>	<u>-19.5</u>
Wall	4	10	13.1	-14.0	14.3	-15.0	15.5	-16.0	18.2	-19.0	<u>19.7</u>	<u>-20.5</u>
	4	20	12.5	-13.0	13.6	-14.0	14.8	-16.0	17.4	-19.0	<u>18.8</u>	<u>-20.5</u>
	4	50	11.7	-12.0	12.8	-14.0	13.9	-15.0	16.3	-17.0	<u>17.7</u>	<u>-18.5</u>
	4	100	11.1	-12.0	12.1	-13.0	13.2	-14.0	15.5	-17.0	<u>16.8</u>	<u>-18.0</u>
	4	500	10.0	-10.0	10.6	-11.0	11.6	-12.0	13.6	-15.0	<u>14.7</u>	<u>-16.0</u>
	5	10	13.1	-17.0	14.3	-19.0	15.5	-20.0	18.2	-24.0	<u>19.7</u>	<u>-26.0</u>
	5	20	12.5	-16.0	13.6	-17.0	14.8	-19.0	17.4	-22.0	<u>18.8</u>	<u>-24.0</u>
	5	50	11.7	-14.0	12.8	-16.0	13.9	-17.0	16.3	-20.0	<u>17.7</u>	<u>-21.5</u>
	5	100	11.1	-13.0	12.1	-14.0	13.2	-16.0	15.5	-19.0	<u>16.8</u>	<u>-20.5</u>
	5	500	10.0	-10.0	10.6	-11.0	11.6	-12.0	13.6	-15.0	<u>14.7</u>	<u>-16.0</u>

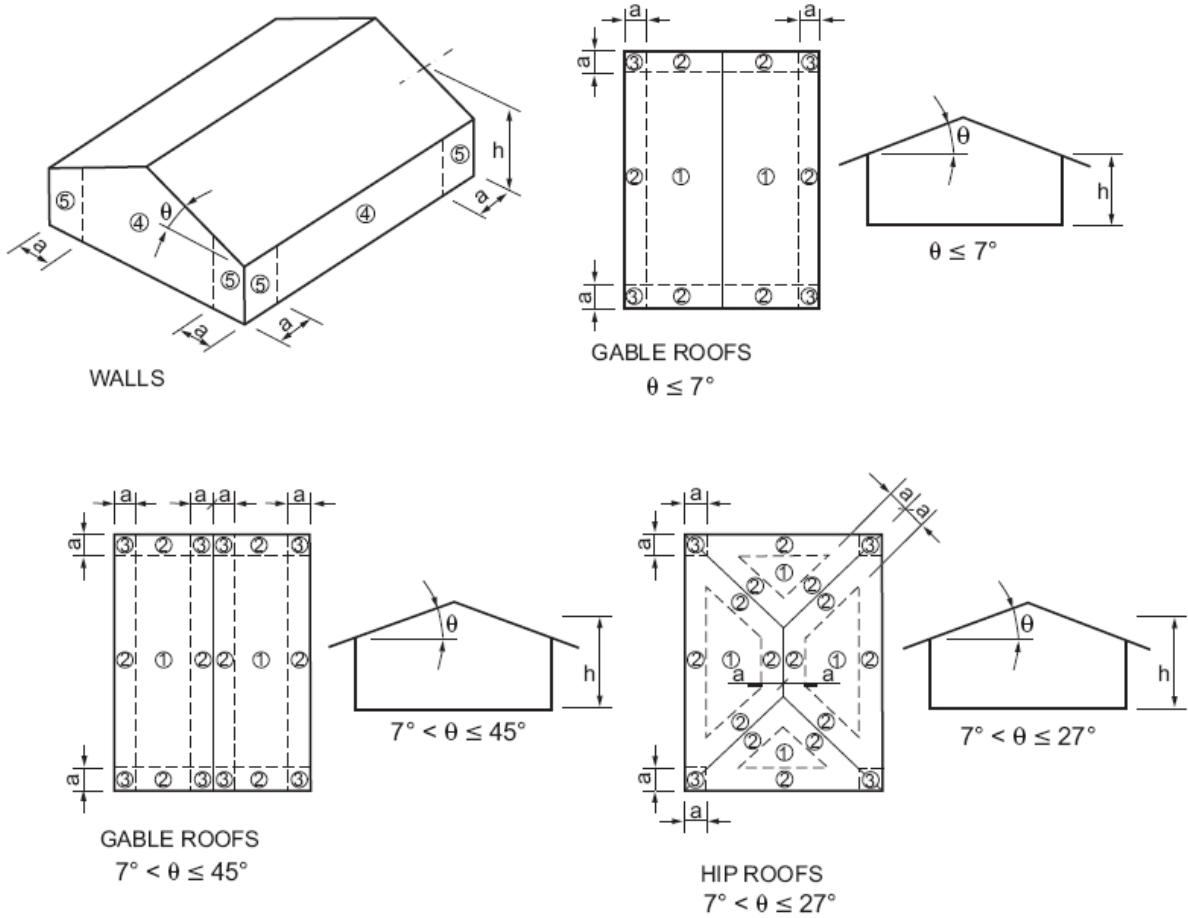
For SI: 1 foot = 304.8 mm, 1 square foot = 0.0929 m<sup>2</sup>, 1 mile per hour = 0.447 m/s, 1 pound per square foot = 0.0479 kPa.

- The effective wind area shall be equal to the span length multiplied by an effective width. This width shall be permitted to be not less than one-third the span length. For cladding fasteners, the effective wind area shall not be greater than the area that is tributary to an individual fastener.
- For effective areas between those given, the load shall be interpolated or the load associated with the lower effective area shall be used.
- Table values shall be adjusted for height and exposure by multiplying by the adjustment coefficient in Table R301.2.1(2).
- See Figure R301.2.1(1) for location of zones.
- Plus and minus signs signify pressures acting toward and away from the building surfaces.



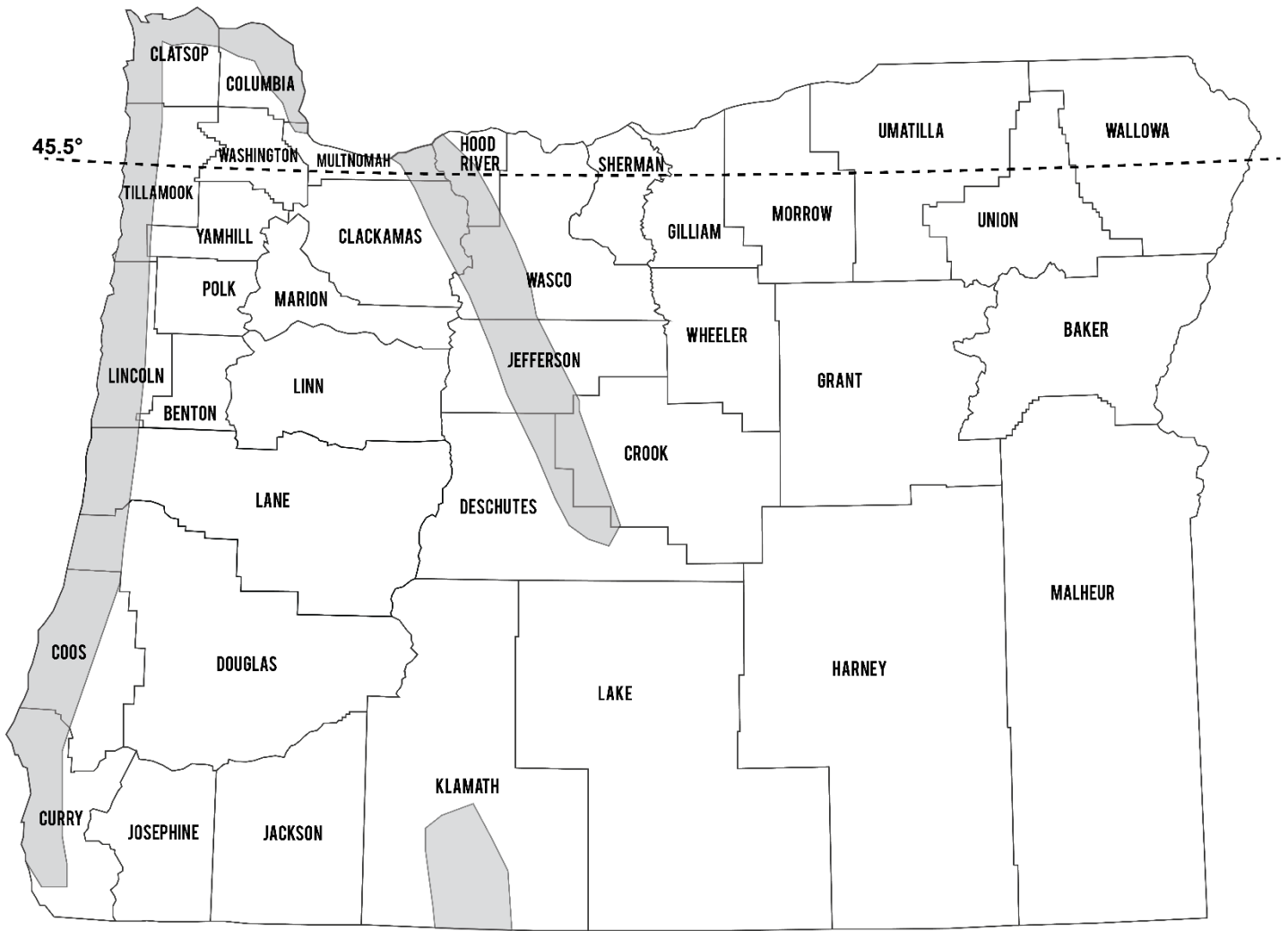
**TABLE R301.2.1(2)**  
**HEIGHT AND EXPOSURE ADJUSTMENT COEFFICIENTS FOR TABLE R301.2.1(1)**

MEAN ROOF HEIGHT	EXPOSURE		
	B	C	D
15	1.00	1.21	1.47
20	1.00	1.29	1.55
25	1.00	1.35	1.61
30	1.00	1.40	1.66
35	1.05	1.45	1.70
40	1.09	1.49	1.74
45	1.12	1.53	1.78
50	1.16	1.56	1.81
55	1.19	1.59	1.84
60	1.22	1.62	1.87



For SI: 1 foot = 304.8 mm, 1 degree = 0.0175 rad.  
 Note:  $a = 4$  feet in all cases.

**FIGURE R301.2.1(1)**  
**COMPONENT AND CLADDING PRESSURE ZONES**



 Special wind regions

**FIGURE R301.2.1**  
**SPECIAL WIND REGIONS – OREGON<sup>a, b</sup>**

- a. Sites on the perimeter of the identified special wind regions shall be verified using [Hazards.atcouncil.org](http://Hazards.atcouncil.org).
- b. Basic design wind speeds shall be obtained from Table R301.2.1(1); see table footnotes for buildings and structures with full exposure (wind exposure category D) to Pacific Ocean or Columbia River Gorge winds.

## Seismic design criteria.

**R301.2.2 Seismic provisions.** Buildings in Seismic Design Categories C, D<sub>0</sub>, D<sub>1</sub>, and D<sub>2</sub> shall be constructed in accordance with the requirements of this section and other seismic requirements of this code. The seismic provisions of this code shall apply as follows:

1. Townhouses in Seismic Design Categories C, D<sub>0</sub>, D<sub>1</sub> and D<sub>2</sub>.
2. Detached one- and two-family dwellings in Seismic Design Categories D<sub>0</sub>, D<sub>1</sub> and D<sub>2</sub>.

Buildings in Seismic Design Category E shall be designed to resist seismic loads in accordance with the *Building Code*, except where the seismic design category is reclassified to Seismic Design Category D<sub>2</sub> in accordance with Section R301.2.2.1. Components of buildings not required to be designed to resist seismic loads shall be constructed in accordance with the provisions of this code.

**R301.2.2.1 Determination of seismic design category.** Buildings shall be assigned a seismic design category in accordance with [Figure R301.2.2.1](#).

**R301.2.2.1.1 Alternate determination of seismic design category.** The value of  $S_{DS}$  determined in accordance with Section 1613.2 of the *Building Code* is permitted to be used to set the seismic design category in accordance with Table R301.2.2.1.1.

**TABLE R301.2.2.1.1  
SEISMIC DESIGN CATEGORY DETERMINATION**

CALCULATED $S_{DS}$	SEISMIC DESIGN CATEGORY
$S_{DS} \leq 0.17g$	A
$0.17g < S_{DS} \leq 0.33g$	B
$0.33g < S_{DS} \leq 0.50g$	C
$0.50g < S_{ps} \leq 0.67g$	D <sub>0</sub>
$0.67g < S_{DS} \leq 0.83g$	D <sub>1</sub>
$0.83g < S_{DS} \leq 1.25g$	D <sub>2</sub>
$1.25g < S_{DS}$	E

**R301.2.2.1.2 Alternative determination of Seismic Design Category E.** Buildings located in Seismic Design Category E in accordance with [Figure R301.2.2.1](#) are permitted to be reclassified as being in Seismic Design Category D<sub>2</sub> provided that one of the following is done:

1. A more detailed evaluation of the seismic design category is made in accordance with the provisions and maps of the *Building Code*. Buildings located in Seismic Design Category E in accordance with Table R301.2.2.1.1 but located in Seismic Design Category D in accordance with the *Building Code*, shall be permitted to be designed using the Seismic Design Category D<sub>2</sub> requirements of this code.
2. Buildings located in Seismic Design Category E that conform to the following additional restrictions are permitted to be constructed in accordance with the provisions for Seismic Design Category D<sub>2</sub> of this code:

- 2.1. All exterior shear wall lines or *braced wall panels* are in one plane vertically from the foundation to the uppermost story.
- 2.2. Floors shall not cantilever past the *exterior walls*.
- 2.3. The building is within the requirements of Section R301.2.2.2.6 for being considered as regular.

**R301.2.2.2 Weights of materials.** Average dead loads shall not exceed 15 pounds per square foot (720 Pa) for the combined roof and ceiling assemblies (on a horizontal projection) or 15 pounds per square foot (720 Pa) for floor assemblies, except as further limited by Section R301.2.2. Dead loads for walls above *grade* shall not exceed:

1. Fifteen pounds per square foot (720 Pa) for exterior light-frame wood walls.
2. Fourteen pounds per square foot (670 Pa) for exterior light-frame cold-formed steel walls.
3. Ten pounds per square foot (480 Pa) for interior light-frame wood walls.
4. Five pounds per square foot (240 Pa) for interior light-frame cold-formed steel walls.
5. Eighty pounds per square foot (3830 Pa) for 8-inch-thick (203 mm) masonry walls.
6. Eighty-five pounds per square foot (4070 Pa) for 6-inch-thick (152 mm) concrete walls.
7. Ten pounds per square foot (480 Pa) for SIP walls.

**Exceptions:**

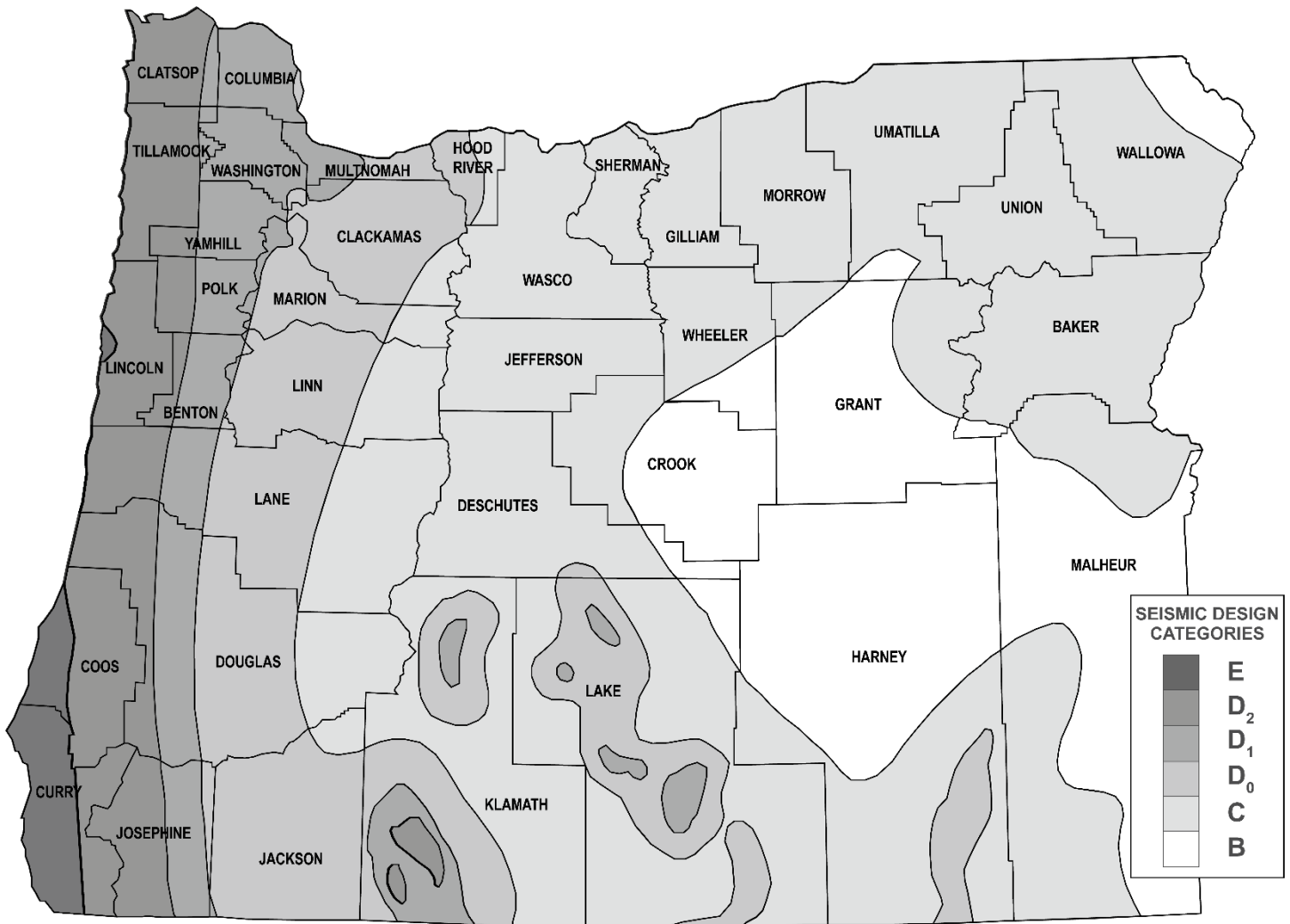
1. Roof and ceiling dead loads **greater than 15 pounds per square foot (720 Pa)**, but not exceeding 25 pounds per square foot (1190 Pa) shall be permitted provided that the wall bracing amounts in Section R602.10.3 are increased in accordance with Table R602.10.3(4).
2. Light-frame walls with stone or masonry veneer shall be permitted in accordance with the provisions of Sections R702.1 and R703.
3. Fireplaces and chimneys shall be permitted in accordance with Chapter 10.

**R301.2.2.3 Stone and masonry veneer.** Anchored stone and masonry veneer shall comply with the requirements of Sections R702.1 and R703.

**R301.2.2.4 Masonry construction.** Masonry construction in Seismic Design Categories D<sub>0</sub> and D<sub>1</sub> shall comply with the requirements of Section R606.12.1. **Masonry construction in Seismic Design Category D<sub>2</sub> shall comply with the requirements of Section R606.12.4.**

**R301.2.2.5 Concrete construction.** Buildings with exterior above-*grade* concrete walls shall comply with PCA 100 or shall be designed in accordance with ACI 318.

**Exception:** Detached one- and two-family dwellings in Seismic Design Category C with exterior above-*grade* concrete walls are allowed to comply with the requirements of Section R608.



**Note:**

Sites on the perimeter of identified seismic design categories shall be verified using the Applied Technology Council (ATC) hazards by location tool at Hazards.atcouncil.org with the following selected information:

- Reference document: ASCE 7-16
- Risk category: II
- Site class: D – Default

The reported value of the short-period design spectral acceleration, SDS, shall be used in conjunction with Table R301.2.2.1.1 for determination of the seismic design category

**FIGURE R301.2.2.1  
SEISMIC DESIGN CATEGORIES**

**Irregular buildings seismic design.**

**R301.2.2.6 Irregular buildings.** The seismic provisions of this code shall not be used for structures, or portions thereof, located in Seismic Design Categories C, D<sub>0</sub>, D<sub>1</sub> and D<sub>2</sub> and considered to be irregular in accordance with this section. A building or portion of a building shall be considered to be irregular where one or more of the conditions defined in Items 1 through 7 occur. Irregular structures, or irregular portions of structures, shall be designed in accordance with accepted engineering practice to the extent the irregular features affect the performance of the remaining structural system. Where the forces associated with the irregularity are resisted by a structural system designed in accordance with accepted engineering practice, the remainder of the building shall be permitted to be designed using the prescriptive

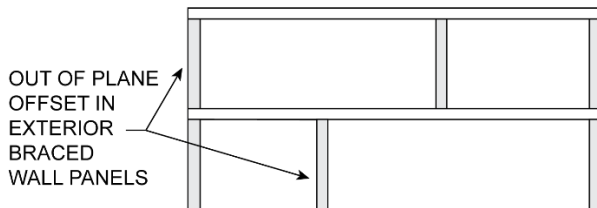
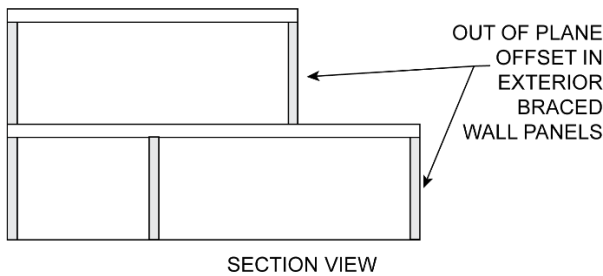
provisions of this code.

1. **Shear wall or braced wall offsets out of plane.** Conditions where exterior shear wall lines or *braced wall panels* are not in one plane vertically from the foundation to the uppermost *story* in which they are required. See Figure R301.2.2.6(1).

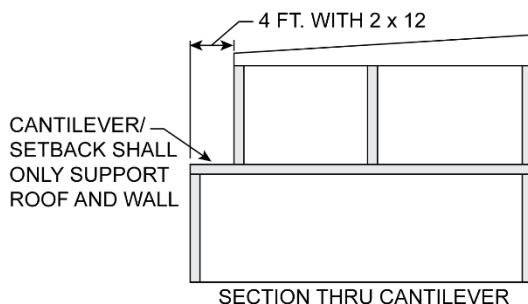
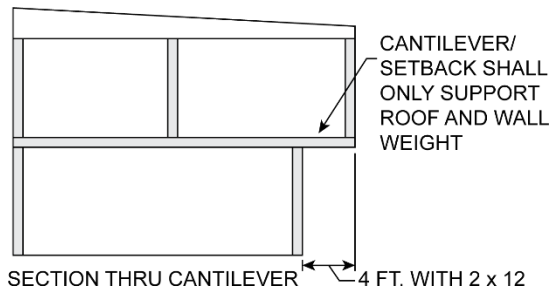
**Exception:** For wood light-frame construction, floors with cantilevers or setbacks not exceeding four times the nominal depth of the wood floor joists [see Figure R301.2.2.6(2)] are permitted to support *braced wall panels* that are out of plane with *braced wall panels* below provided that all of the following are satisfied:

1. Floor joists are nominal 2 inches by 10 inches (51 mm by 254 mm) or larger and spaced not more than 16 inches (406 mm) on center.

2. The ratio of the back span to the cantilever is not less than 2 to 1.
3. Floor joists at ends of *braced wall panels* are doubled.
4. For wood-frame construction, a continuous rim joist is connected to ends of cantilever joists. Where spliced, the rim joists shall be spliced using a galvanized metal tie not less than 0.058 inch (1.5 mm) (16 gage) and 1½ inches (38 mm) wide fastened with six 16d nails on each side of the splice; or a block of the same size as the rim joist and of sufficient length to fit securely between the joist space at which the splice occurs, fastened with eight 16d nails on each side of the splice.
5. Gravity loads carried at the end of cantilevered joists are limited to uniform wall and roof loads and the reactions from headers having a span of 8 feet (2438 mm) or less.



**FIGURE R301.2.2.6(1)**  
**BRACED WALL PANELS OUT OF PLANE**

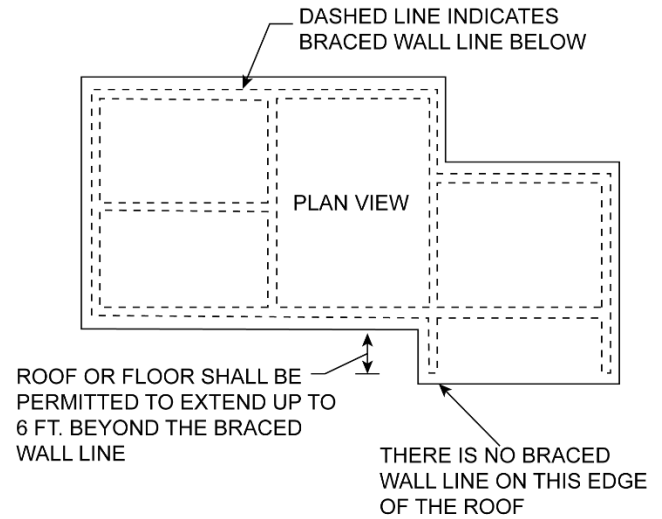


For SI: 1 foot = 304.8 mm.

**FIGURE R301.2.2.6(2)**  
**BRACED WALL PANELS SUPPORTED BY CANTILEVER OR SETBACK**

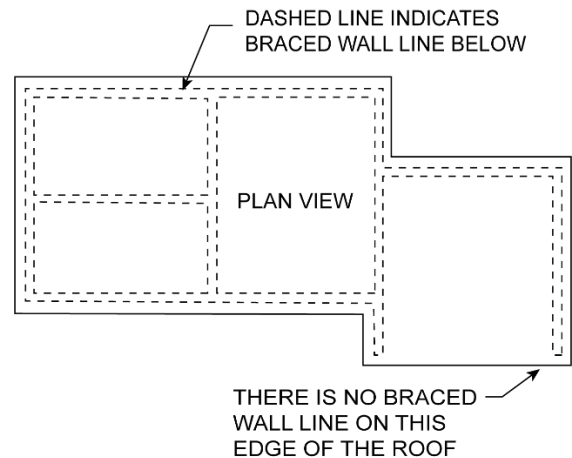
2. **Lateral support of roofs and floors.** Conditions where a section of floor or roof is not laterally supported by shear walls or *braced wall lines* on all edges. [See Figure R301.2.2.6\(3\).](#)

**Exception:** Portions of floors that do not support shear walls, *braced wall panels* above, or roofs shall be permitted to extend not more than 6 feet (1829 mm) beyond a shear wall or *braced wall line*. [See Figure R301.2.2.6\(4\).](#)



For SI: 1 foot = 304.8 mm.

**FIGURE R301.2.2.6(3)**  
**FLOOR OR ROOF NOT SUPPORTED AT ALL EDGES**



For SI: 1 foot = 304.8 mm.

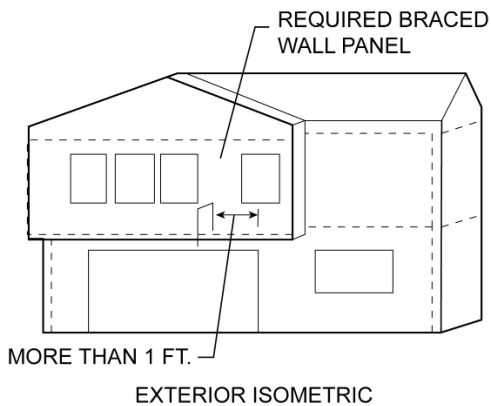
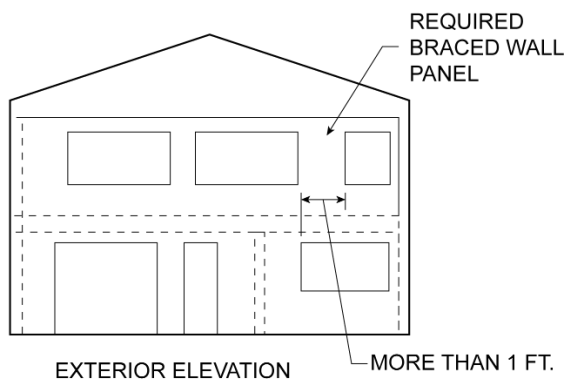
**FIGURE R301.2.2.6(4)**  
**ROOF OR FLOOR EXTENSION BEYOND BRACED WALL LINE**

3. **Shear wall or braced wall offsets in plane.** Conditions where the end of a *braced wall panel* occurs over an opening in the wall below and extends more than 1 foot (305 mm) horizontally past the edge of the opening. This provision is applicable to shear walls and *braced wall panels* offset in plane and to *braced wall panels* offset out of plane in accordance with the exception to Item 1. [See Figure R301.2.2.6\(5\).](#)

**Exception:** For wood light-frame wall construction, one end of a *braced wall panel* shall be permitted to extend more than 1 foot (305 mm) over an opening not more than

8 feet (2438 mm) in width in the wall below provided that the opening includes a header in accordance with all of the following:

1. The building width, loading condition and framing member species limitations of Table R602.7(1) shall apply.
2. The header is composed of:
  - 2.1. Not less than one  $2 \times 12$  or two  $2 \times 10$  for an opening not more than 4 feet (1219 mm) wide.
  - 2.2. Not less than two  $2 \times 12$  or three  $2 \times 10$  for an opening not more than 6 feet (1829 mm) in width.
  - 2.3. Not less than three  $2 \times 12$  or four  $2 \times 10$  for an opening not more than 8 feet (2438 mm) in width.
3. The entire length of the *braced wall panel* does not occur over an opening in the wall below.



For SI: 1 foot = 304.8 mm.

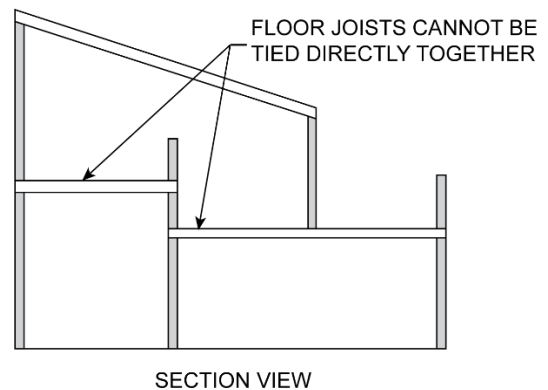
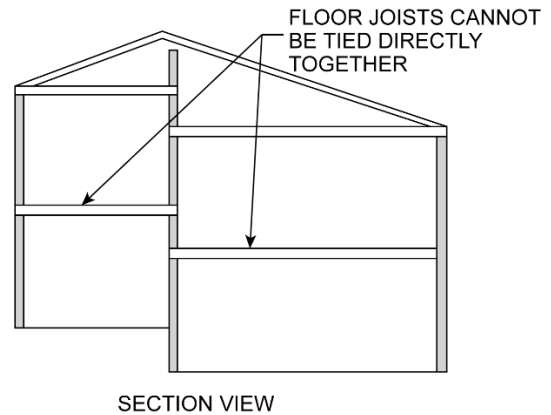
**FIGURE R301.2.2.6(5)**  
**BRACED WALL PANEL EXTENSION OVER OPENING**

4. **Floor and roof opening.** Conditions where an opening in a floor or roof exceeds the lesser of 12 feet (3658 mm) or 50 percent of the least floor or roof dimension between adjacent braced wall lines. See Figure R301.2.2.6(6).
5. **Floor level offset.** Conditions where portions of a floor level are vertically offset.

**Exceptions:**

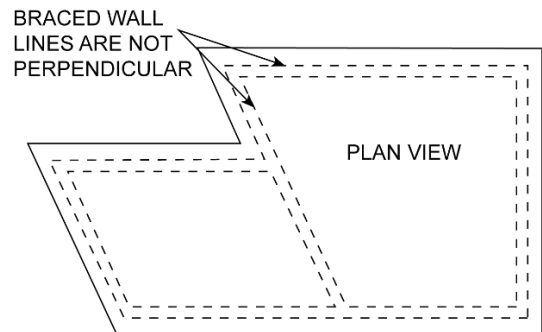
1. Framing supported directly by continuous foundations at the perimeter of the building.

2. For wood light-frame construction, floors shall be permitted to be vertically offset where the floor framing is lapped or tied together as required by Section R502.6.1. See Figure R301.2.2.6(7).



**FIGURE R301.2.2.6(7)**  
**PORTIONS OF FLOOR LEVEL OFFSET VERTICALLY**

6. **Perpendicular shear wall and wall bracing.** Conditions where shear walls and *braced wall lines* do not occur in two perpendicular directions. See Figure R301.2.2.6(8).

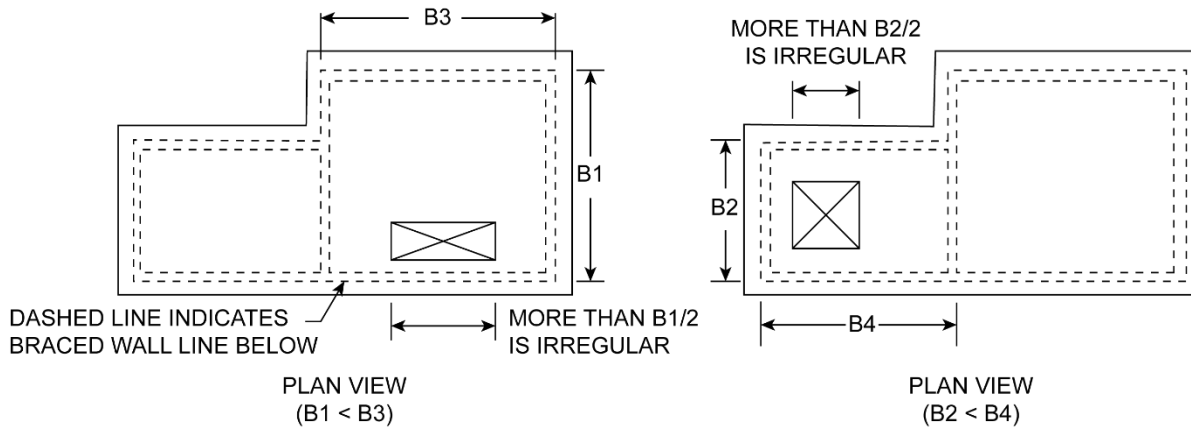


**FIGURE R301.2.2.6(8)**  
**BRACED WALL LINES NOT PERPENDICULAR**

7. **Wall bracing in stories containing masonry or concrete construction.** Conditions where stories above *grade plane* are partially or completely braced by wood wall framing in accordance with Section R602 or cold-formed steel wall framing in accordance with Section R603 include masonry or concrete construction. Where this irregularity applies, the entire story shall be designed in accordance with accepted engineering practice.

**Exceptions:** Fireplaces, chimneys and masonry veneer in accordance with this code.





**FIGURE R301.2.2.6(6)**  
**OPENING LIMITATIONS FOR FLOOR AND ROOF DIAPHRAGMS**

**R301.2.2.7 Height limitations.** Wood-framed buildings shall be limited to three stories above *grade plane* or the limits given in Table R602.10.3(3). Cold-formed steel-framed buildings shall be limited to less than or equal to three stories above *grade plane* in accordance with AISI S230. Mezzanines as defined in Section R202 that comply with Section R325 shall not be considered as stories. Structural insulated panel buildings shall be limited to two stories above *grade plane*.

**R301.2.2.8 Cold-formed steel framing in Seismic Design Categories D<sub>0</sub>, D<sub>1</sub> and D<sub>2</sub>.** In Seismic Design Categories D<sub>0</sub>, D<sub>1</sub> and D<sub>2</sub> in addition to the requirements of this code, cold-formed steel framing shall comply with the requirements of AISI S230.

**R301.2.2.9 Masonry chimneys.** In Seismic Design Categories D<sub>0</sub>, D<sub>1</sub> and D<sub>2</sub>, Masonry chimneys shall be reinforced and anchored to the building in accordance with Sections R1003.3 and R1003.4.

**R301.2.2.10 Anchorage of water heaters.** In Seismic Design Categories D<sub>0</sub>, D<sub>1</sub> and D<sub>2</sub>, Water heaters shall be anchored against movement and overturning in accordance with Section M1307.2.

## Snow loads.

**R301.2.3 Snow loads.** Wood-framed construction, cold-formed, steel-framed construction and masonry and concrete construction, and structural insulated panel construction in regions with ground snow loads 70 pounds per square foot (3.35 kPa) or less, shall be in accordance with Chapters 5, 6 and 8. Buildings in regions with ground snow loads greater than 70 pounds per square foot (3.35 kPa) shall be designed in accordance with accepted engineering practice.

**R301.2.3.1 Ground Snow Load Determination.** Site-specific ground snow loads,  $p_g$ , shall be those set forth in the online lookup tool at [Snowload.seao.org/lookup.html](http://Snowload.seao.org/lookup.html). Where the site elevation is higher than the modeled elevation reported by the online lookup tool, the reported ground snow load values shall be adjusted by adding the specified loads from Table R301.2.3.1. The minimum ground snow load for prescriptive design is 36 psf (1.724 kN/m<sup>2</sup>). The minimum roof snow load for engineered design is 25 psf (1.197 kN/m<sup>2</sup>).

**TABLE R301.2.3.1  
GROUND SNOW LOAD ADJUSTMENT**

<u>REGION</u>	<u>GROUND SNOW ADJUSTMENT LOADS (psf per foot of elevation gain)</u>
<u>Oregon Coast Mountains</u>	<u>0.07</u>
<u>Interior and Willamette Valleys</u>	<u>0.04</u>
<u>Cascade Mountains</u>	<u>0.07</u>
<u>Siskiyou and Kalmiopsis Mountains</u>	<u>0.04</u>
<u>Plains east of the Cascades</u>	<u>0.007</u>
<u>Klamath Basin</u>	<u>0.008</u>
<u>Eastern Oregon Mountains</u>	<u>0.04</u>

## Minimum live load.

**R301.5 Live load.** The minimum live loads shall be as provided in Table R301.5.

**TABLE R301.5  
MINIMUM LIVE LOADS**

<u>USE</u>	<u>UNIFORM LOAD</u>	<u>CONCENTRATED LOAD (pounds)</u>
Uninhabitable attics without storage <sup>b</sup>	10	--
Uninhabitable attics with limited storage <sup>b, g</sup>	20	--
<u>Habitable</u> attics served with fixed stairs	30	--
Balconies (exterior) and decks <sup>e</sup>	40	--
Fire escapes	40	--
Guards <sup>i</sup> and handrails <sup>d</sup>	--	<u>200<sup>h</sup></u>
Guard in-fill components <sup>f</sup>	--	<u>50<sup>h</sup></u>
Passenger vehicle garages <sup>a</sup>	50 <sup>a</sup>	<u>2000<sup>a</sup></u>
Rooms other than sleeping rooms	40	--
Sleeping rooms	30	--
Stairs	40 <sup>c</sup>	<u>300<sup>c</sup></u>

For SI: 1 inch = 25.4 mm, 1 foot = 304.8 mm, 1 pound per square foot = 0.0479 kPa, 1 square inch = 645 mm<sup>2</sup>, 1 pound = 4.45 N.

- a. Independent of the 50 psf uniform load case, elevated garage floors shall also be capable of supporting two 2,000-pound loads each applied over 4.5-inch by 4.5-inch areas centered 5 feet apart perpendicular to the direction of vehicle entry and a second pair of 2,000-pound loads 9 feet from the first pair of 2,000-pound loads parallel to the direction of vehicle entry. This combination of concentrated loads shall be applied where they cause the maximum bending moment and deflection, and separately where they cause the maximum shear and bearing stress of the supporting framing members, but need not be applied closer than 2 feet from the interior end wall nor closer than 1 foot from interior sidewalls.
- b. Uninhabitable *attics* without storage are those where the clear height between joists and rafters is not more than 42 inches, or where there are not two or more adjacent trusses with web configurations capable of accommodating an assumed rectangle 42 inches in height by 24 inches in width, or greater, within the plane of the trusses. This live load need not be assumed to act concurrently with any other live load requirements.
- c. Individual stair treads shall be designed for the uniformly distributed live load or a 300-pound concentrated load acting over an area of 4 square inches, whichever produces the greater stresses.
- d. A single concentrated load applied in any direction at any point along the top.
- e. See Section R507.1 for decks attached to *exterior walls*.
- f. *Guard* in-fill components (all those except the handrail), balusters and panel fillers shall be designed to withstand a horizontally applied normal load of 50 pounds on an area equal to 1 square foot. This load need not be assumed to act concurrently with any other live load requirement.
- g. Uninhabitable *attics* with limited storage are those where the clear height between joists and rafters is 42 inches or greater, or where there are two or more adjacent trusses with web configurations capable of accommodating an assumed rectangle 42 inches in height by 24 inches in width, or greater, within the plane of the trusses.  
The live load need only be applied to those portions of the joists or truss bottom chords where all of the following conditions are met:
  1. The *attic* area is accessed from an opening not less than 20 inches in width by 30 inches in length that is located where the clear height in the *attic* is not less than 30 inches.
  2. The slopes of the joists or truss bottom chords are not greater than 2 units vertical to 12 units horizontal.
  3. Required insulation depth is less than the joist or truss bottom chord member depth.
The remaining portions of the joists or truss bottom chords shall be designed for a uniformly distributed concurrent live load of not less than 10 pounds per square foot.
- h. Glazing used in handrail assemblies and *guards* shall be designed with a safety factor of 4. The safety factor shall be applied to each of the concentrated loads applied to the top of the rail, and to the load on the infill components. These loads shall be determined independent of one another, and loads are assumed not to occur with any other live load.
- i. Where the top of a guard is not required to serve as a handrail, the single concentrated load shall be applied at any point along the top, in the vertical downward direction and in the horizontal direction away from the walking surface. Concentrated loads shall not be applied concurrently.

## Fire separation distance.

**R302.1 Exterior walls.** Construction, projections, openings and penetrations of *exterior walls* of *dwelling*s and *accessory structures* shall comply with Table R302.1. Where multiple detached dwellings are located on a single lot, each detached dwelling shall comply independently with Table R302.1.

### Exceptions:

1. Walls, projections, openings or penetrations in walls perpendicular to the line used to determine the *fire separation distance*.
2. Walls of *individual dwelling units* and their *accessory structures* located on the same *lot*.
3. Detached nonhabitable accessory structures exempted from permits are not required to provide wall protection based on location on the *lot*. Projections beyond the *exterior wall* shall not extend over the *lot line*.
4. Detached garages accessory to a *dwelling* located within 2 feet (610 mm) of a *lot line* are permitted to have roof eave projections not exceeding 4 inches (102 mm).
5. Foundation vents installed in compliance with this code are permitted.
6. Attached decks that are exempt from permitting by Section R105.2. All other attached decks shall be considered projections for compliance with Table R302.1.

**TABLE R302.1  
EXTERIOR WALLS**

EXTERIOR WALL ELEMENT		MINIMUM FIRE-RESISTANCE RATING	FIRE SEPARATION DISTANCE <u>PROVIDED</u>
Walls	Fire-resistance rated	1 hour—tested in accordance with ASTM E119 or UL 263 with exposure from both sides	< 3 feet
	Not fire-resistance rated	0 hours	≥ 3 feet
Projections <sup>c</sup>	Not allowed	N/A	< 2 feet
	Fire-resistance rated	1 hour on the underside <sup>a, b</sup>	≥ 2 feet to < 3 feet
	Not fire-resistance rated	0 hours	≥ 3 feet
Openings in walls	Not allowed	N/A	< 3 feet
	Unlimited	0 hours	≥ 3 feet
Penetrations	All	Comply with Section R302.4	< 3 feet
		None required	≥ 3 feet

For SI: 1 foot = 304.8 mm. NA = Not Applicable.

- a. The fire-resistance rating shall be permitted to be reduced to 0 hours on the underside of the eave overhang if fireblocking is provided from the wall top plate to the underside of the roof sheathing. Fireblocking shall consist of not less than two layers of two-inch (51 mm) nominal lumber.
- b. The fire-resistance rating shall be permitted to be reduced to 0 hours on the underside of the rake overhang where gable vent openings are not installed.
- c. For the purposes of this table, attached decks that are not exempted by Section R105.2 shall be considered projections.

## Townhouses.

**R302.2 Townhouses.** Each *townhouse* shall be considered a separate building and shall adjoin or have access to a yard, street, alley or public way on not less than two sides. The centerline of an adjoining public way shall be considered an adjacent property line. Each *townhouse* shall be constructed in accordance with Sections R302.2.1 through R302.2.11.

### **R302.2.1 Townhouse separation wall assemblies.**

*Townhouses* shall be separated by 2-hour fire-resistance-rated wall assemblies in accordance with one of the following requirements:

1. Two 1-hour fire-resistance-rated firewalls, one on each side of the common property line as shown in Figures R302.2.1(1) and R302.2.1(2).
2. A common “modified” 2-hour fire-resistance-rated firewall centered over the common property line as shown in Figures R302.2.1(3) and R302.2.1(4). Plumbing or mechanical equipment ducts or vents are not permitted in the cavity of the “modified” 2-hour wall, except as specifically detailed in Section R302.4.2.1. Electrical installations shall be installed in accordance with the *Electrical Code*. Penetrations of electrical outlet boxes shall be in accordance with Section R302.4.
3. A common 2-hour fire-resistance-rated wall. Plumbing or mechanical equipment ducts or vents are not permitted in the cavity of the common 2-hour fire-resistance-rated wall. Electrical installations shall be installed in accordance with the *Electrical Code*. Penetrations of electrical outlet boxes shall be in accordance with Section R302.4.

**Exception:** A common 2-hour fire-resistance-rated wall is not permitted in *townhouses* that are separated by a real property line.

4. Other *listed* and tested assemblies that provide an equivalent fire-protection rating.

**Exception:** Privacy walls may be constructed of heavy timber construction.

*Townhouse* separation wall assemblies shall be permitted to be reduced to 1-hour fire-resistance-rated wall assemblies where an automatic fire sprinkler system is installed in accordance with NFPA 13D.

**R302.2.2 Mixed occupancies.** Mixed occupancies are not permitted in *townhouses*. Such buildings shall be designed and constructed in accordance with the requirements set forth for mixed occupancies or live/work units in the *Building Code*.

**Exception:** Private garages and carports attached to *townhouses* and totaling not more than 1,000 square feet (92.9m<sup>2</sup>) in area per individual *townhouse*.

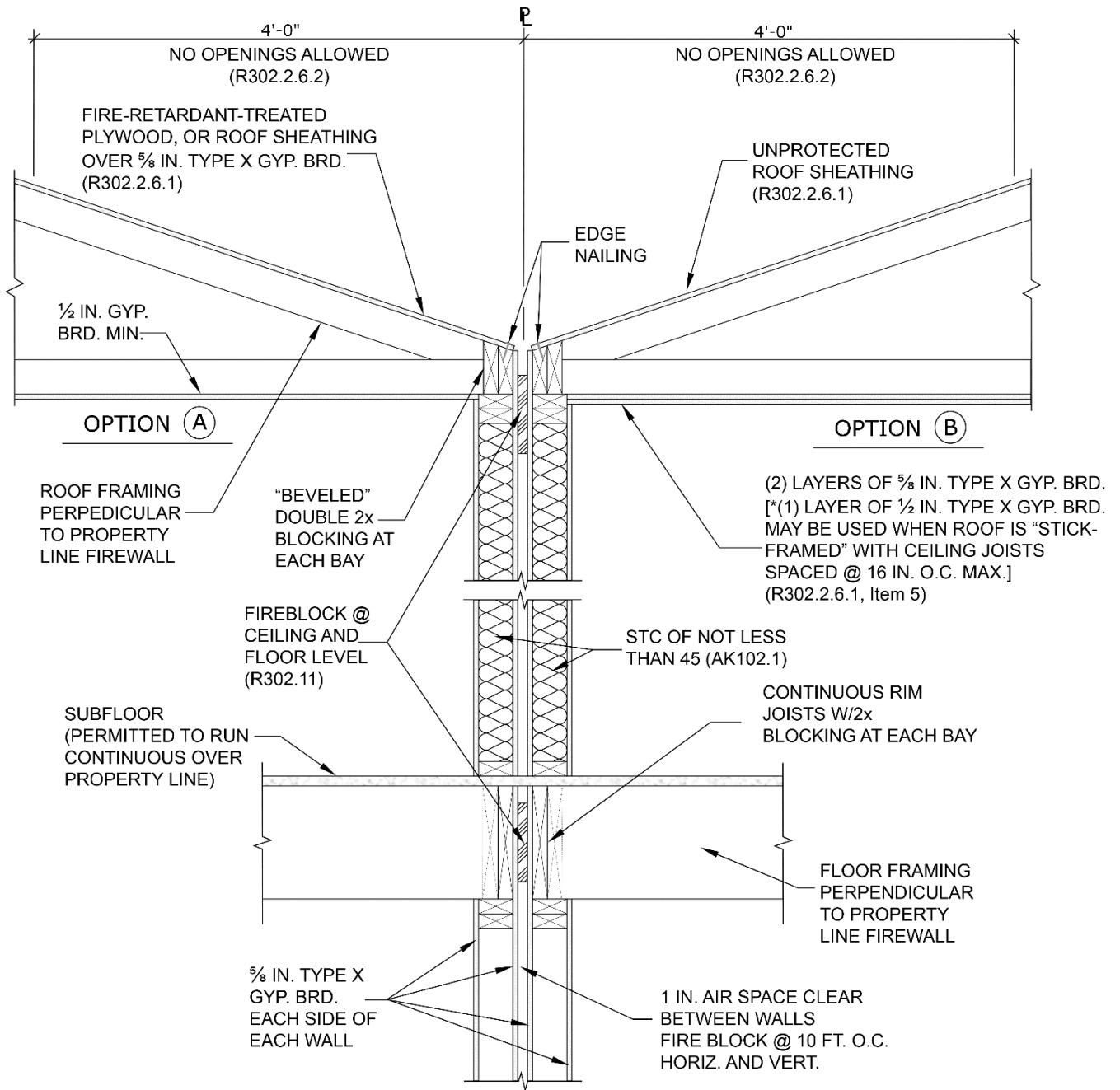
**R302.2.3 Utilities for townhouses.** Shared or common-use utilities shall not run beneath a *townhouse*. Separate utility services shall be supplied to each individual *townhouse*. Utilities serving an individual *townhouse* shall not run beneath another separate *townhouse*, and shall not run through the *attic* of another separate *townhouse*.

**R302.2.4 Fire-resistance-rated wall continuity.** The fire-resistance-rated wall or assembly separating *townhouses* shall be continuous from the foundation to the underside of the roof sheathing, deck or slab. The fire-resistance rating shall extend the full length of the wall or assembly, including wall extensions through and separating attached enclosed *accessory structures*. The fire-resistance-rated walls shall be in accordance with the following:

1. *Exterior walls* and common *townhouse* separation walls shall be continuous from the foundation to the underside of the roof sheathing where the roof/ceiling assembly is constructed in accordance with Section R302.2.6.1 The common *townhouse* separation wall shall extend to completely separate adjacent *townhouses* and any attached *accessory structures*.
2. Privacy walls separating porches and decks without a cover shall be continuous from the foundation to the top of the *guard* and have a height of not less than 3 feet (914 mm) above the porch or deck finish floor elevation. The privacy wall shall extend to the furthest point of the porch or deck.
3. Privacy walls separating porch and deck coverings shall be continuous from the foundation to the underside of the roof sheathing when the roof/ceiling assembly is constructed in accordance with Section R302.2.6.1 The privacy wall shall extend to the furthest point of the porch covering.
4. Fire-resistance-rated gypsum wallboard used in *exterior walls*, privacy walls and common *townhouse* separation walls shall be continuous behind building elements such as showers, bathtubs, cabinets, chases, soffits, electrical panels and stair stringers.

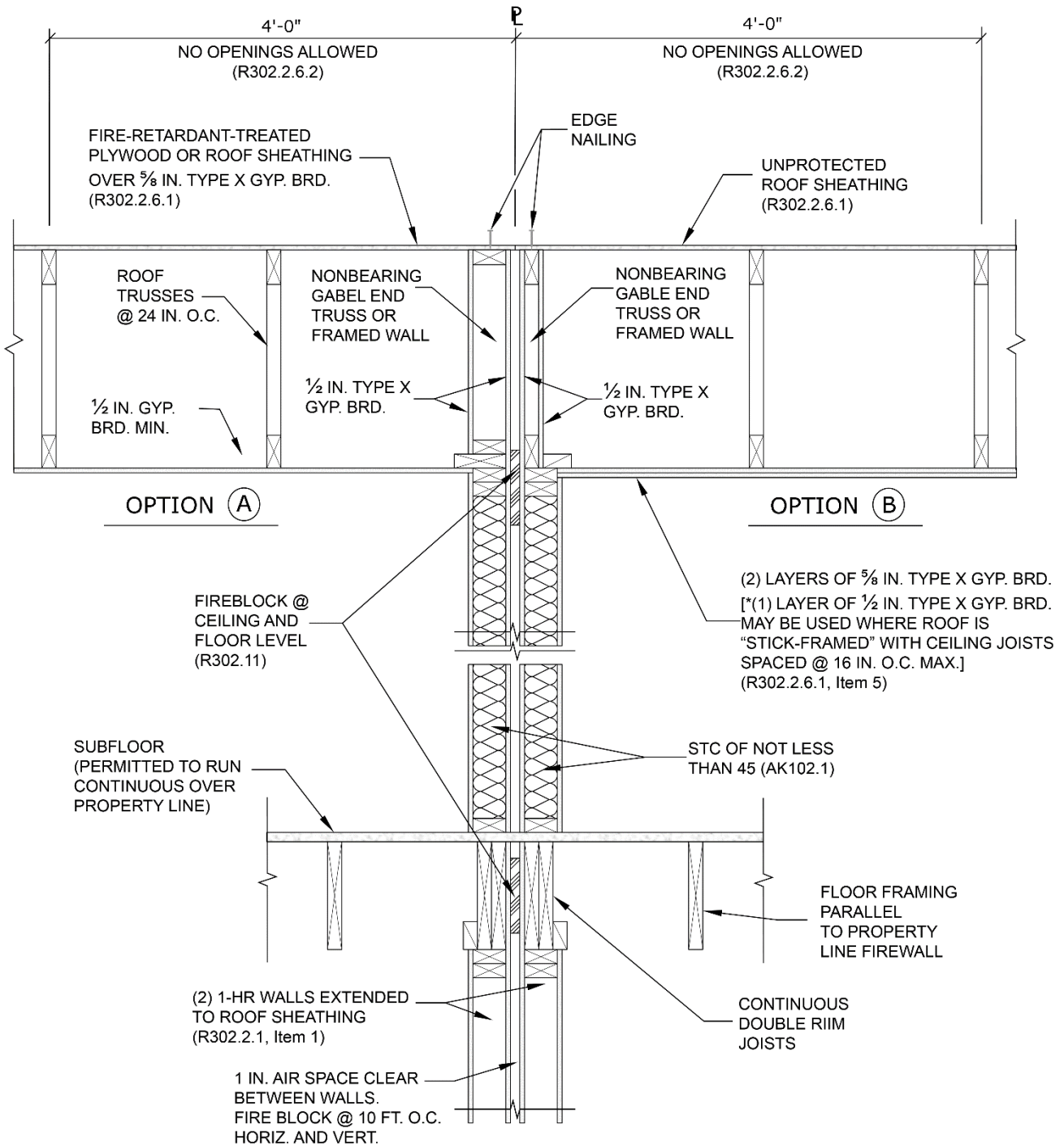
**Exception:** Gypsum board may be omitted behind stair stringers, provided that the stringers are constructed of one of the following:

1. Solid sawn dimensional lumber of not less than 3 inches (76 mm) nominal thickness when used in conjunction with two 1-hour fire-resistance-rated wall assemblies as shown in Figure R302.2.4 (Detail A).
2. Solid sawn dimensional lumber of not less than 4.5 inches (114 mm) nominal thickness when used in conjunction with a 2-hour fire-resistance-rated wall assembly as shown in Figure R302.2.4 (Detail B).
3. Engineered wood systems that have been tested and listed for equivalent burning characteristics.



For SI: 1 inch = 25.4 mm.

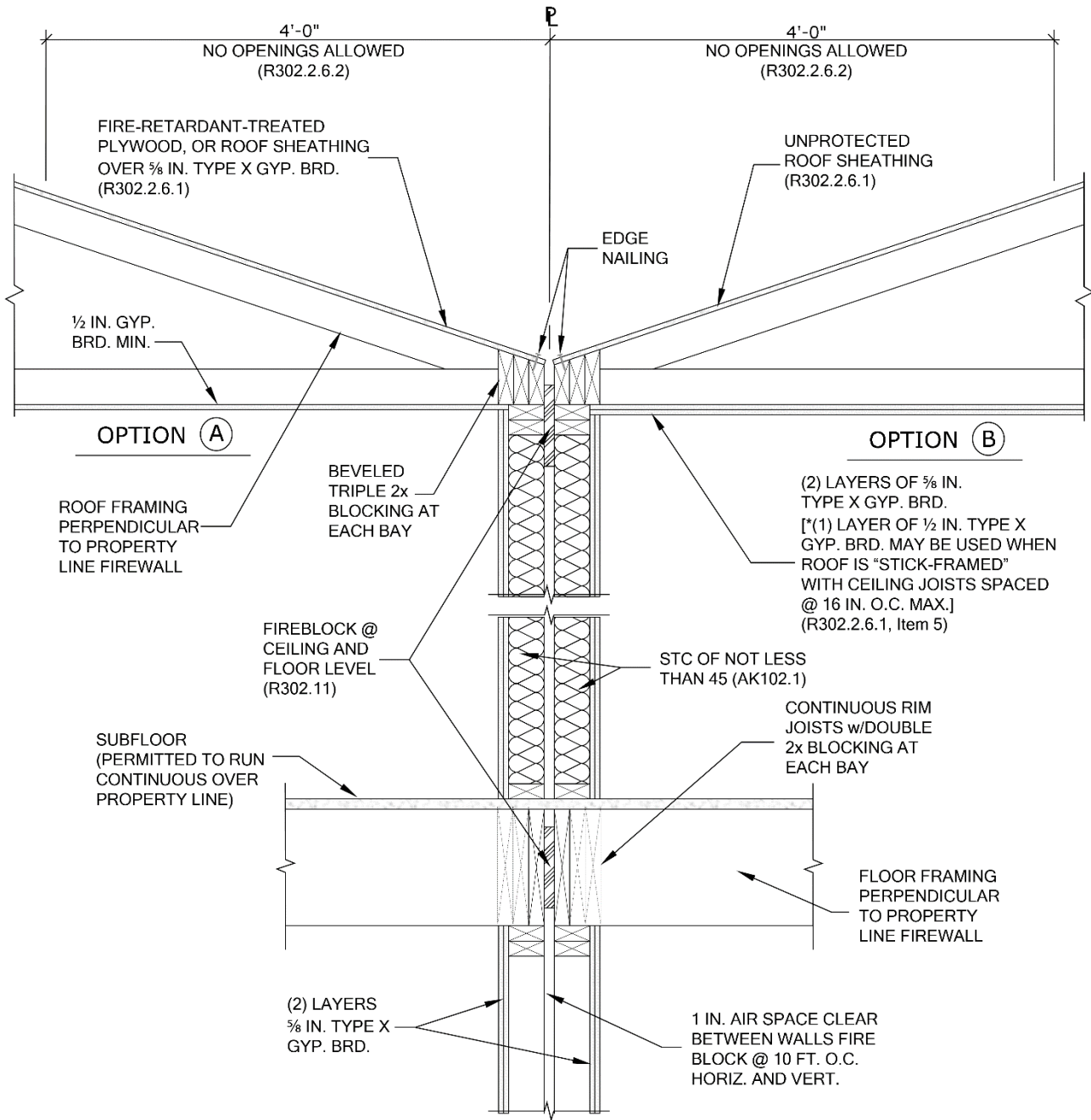
**FIGURE R302.2.1(1)**  
**TWO 1-HOUR FIREWALLS PERPENDICULAR TO COMMON PROPERTY LINE**



For SI: 1 inch = 25.4 mm.

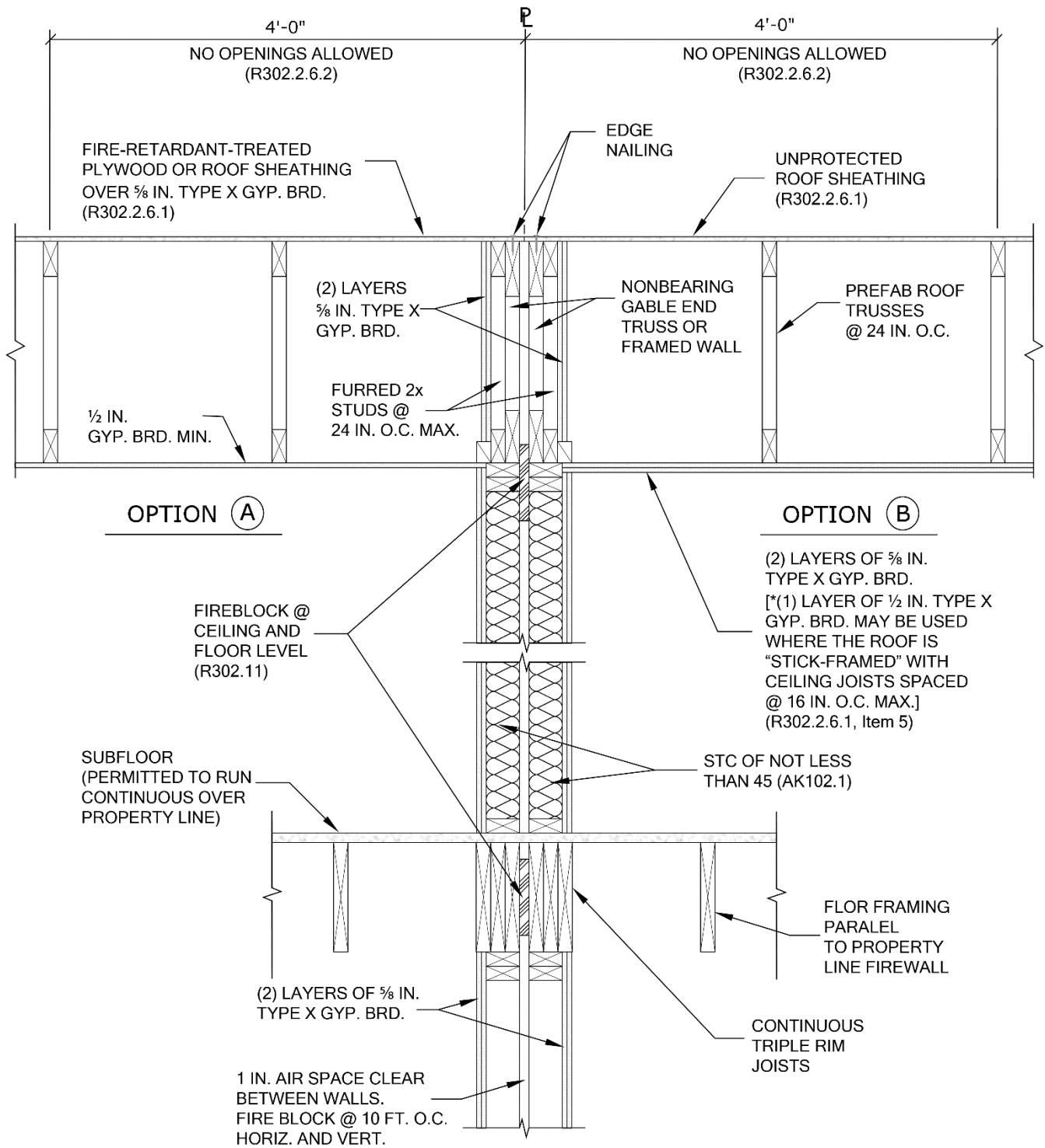
**FIGURE R302.2.1(2)**  
**TWO 1-HOUR FIREWALL PARALLEL TO COMMON PROPERTY LINE**





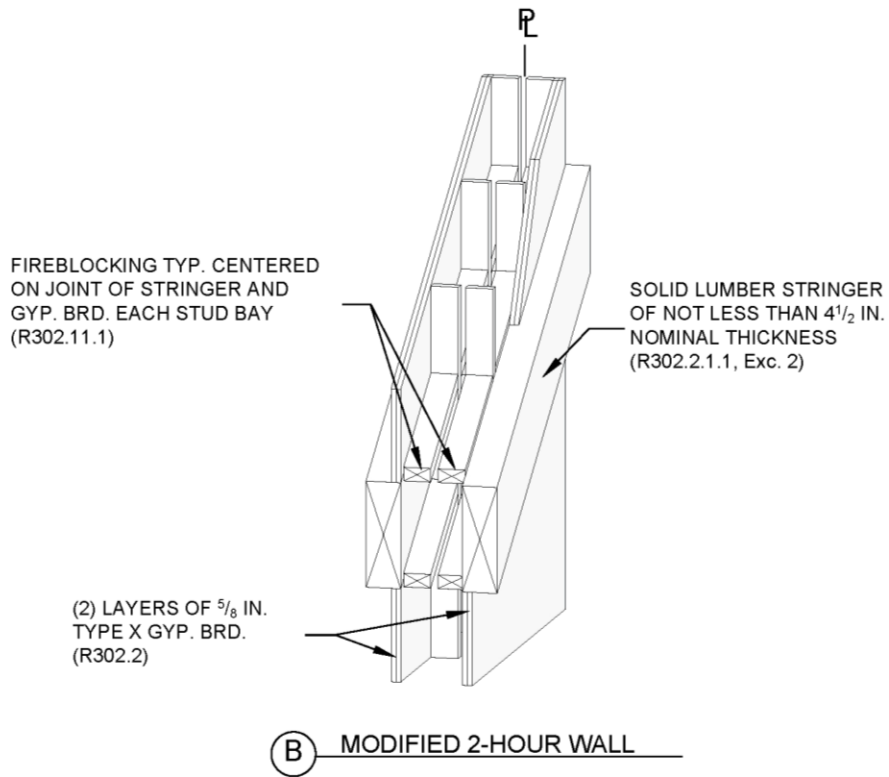
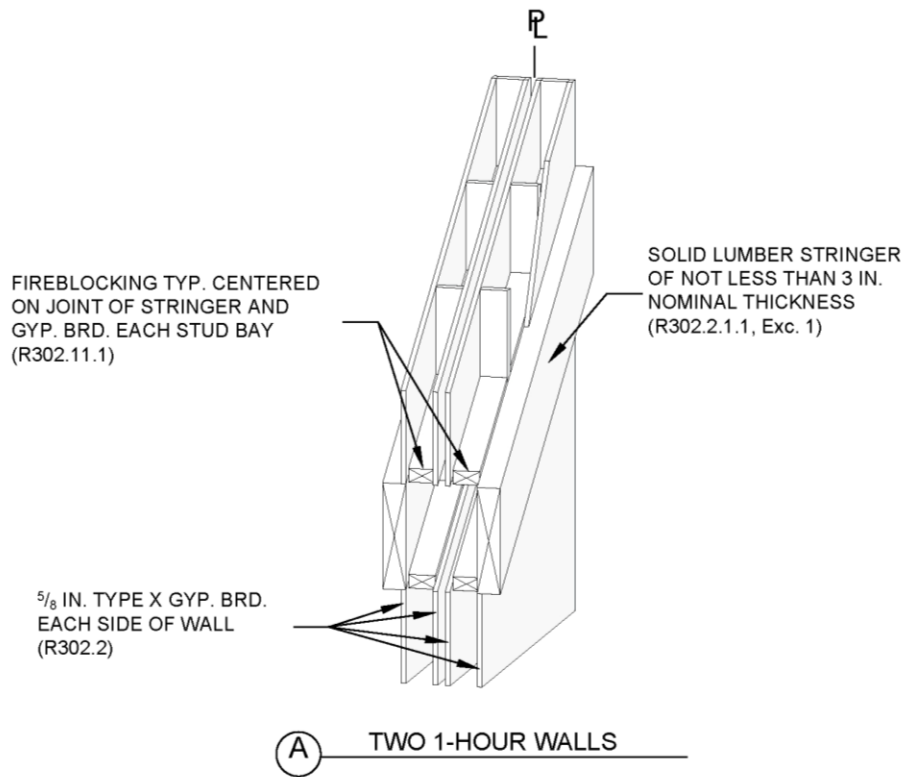
For SI: 1 inch = 25.4 mm.

**FIGURE R302.2.1(3)**  
**"MODIFIED" 2-HOUR FIREWALL PERPENDICULAR TO COMMON PROPERTY LINE**



For SI: 1 inch = 25.4 mm.

**FIGURE R302.2.1(4)**  
**"MODIFIED" 2-HOUR FIREWALL PARALLEL TO COMMON PROPERTY LINE**



For SI: 1 inch = 25.4 mm.

**FIGURE R302.2.4**  
**STRINGER PENETRATIONS OF FIREWALL AT COMMON PROPERTY LINE**

**R302.2.4.1 Porches and decks without a cover.** Fire-resistance-rated protection shall be provided for porches and decks without a cover in accordance with the following methods:

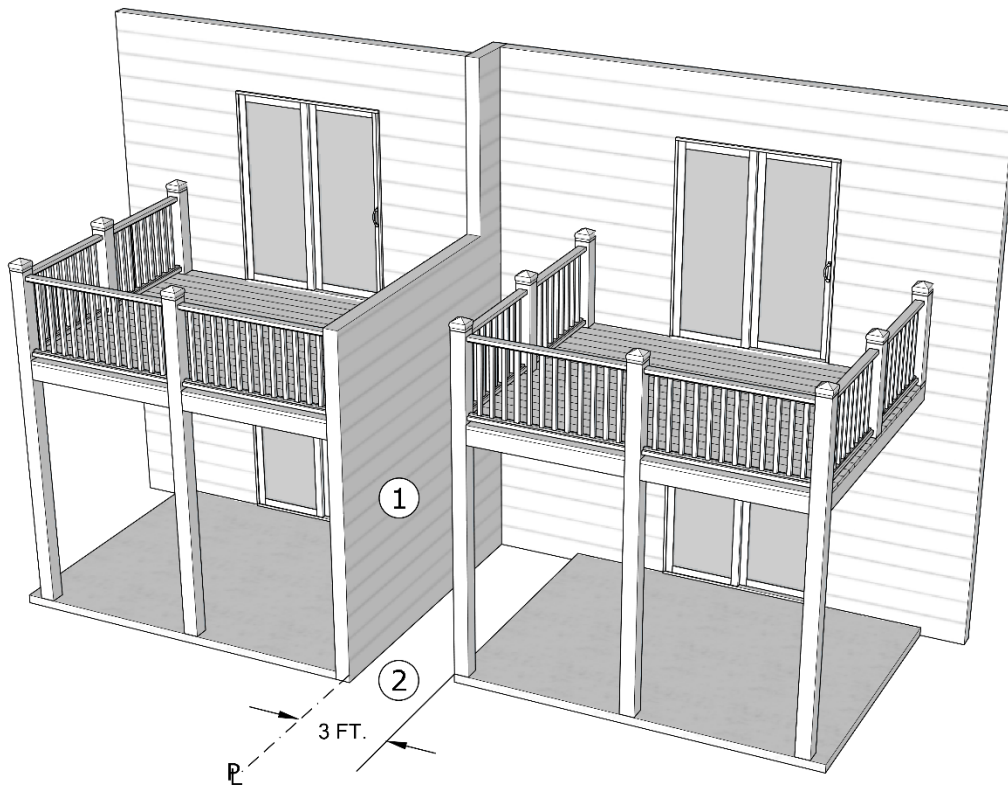
1. Where one porch or deck is adjacent to another porch or deck, and both are less than 3 feet (914 mm) from a common property line, a single 1-hour fire-resistance-rated privacy wall shall be provided for each porch or deck. The privacy wall shall extend to the furthest point where the porches or decks are adjacent.
2. Where one porch or deck abuts another adjacent porch or deck at a common property line, either two 1-hour fire-resistance-rated walls or one “modified” 2-hour fire-resistance-rated common *townhouse* separation wall shall be provided. The *townhouse* separation wall shall extend to the furthest point where the porches or decks are adjacent.
3. Where a porch or deck is less than 3 feet (914 mm) from a common property line and there is no adjacent porch or deck less than 3 feet (914 mm) from the common property line, the porch or deck shall be of either

noncombustible or heavy timber construction (see Figure R302.2.4). Heavy timber porch components supporting only the dead load of the porch or deck and the live load listed in Table R301.5 shall be constructed in accordance with the following:

- 3.1 Supporting posts for porches and decks shall be not less than 6 inches (153 mm) in nominal thickness.
- 3.2 Joists or beams supporting porches and decks shall be not less than 4 inches (102 mm) in nominal thickness.
- 3.3 Decking on porches and decks shall be not less than 2 inches (51 mm) in nominal thickness.

Porches and decks that extend beyond the privacy wall on only one side need not be protected past the privacy wall unless they are less than 3 feet (914 mm) from a common property line.

**Exception:** Porches and decks without a cover and located less than 3 feet (914 mm) from a common property line need not be fire-resistance-rated when the finished floor of the deck or porch is less than 30 inches (762 mm) above *grade*.



- ① DECK LOCATED LESS THAN 3 FEET FROM A PROPERTY LINE SHALL BE PROTECTED AT THE PROPERTY LINE WITH ONE-HOUR WALLS THAT EXTEND FROM GRADE LEVEL TO A MINIMUM HEIGHT OF 36 INCHES ABOVE THE DECK, OR THE HEIGHT OF THE GUARDRAIL, WHICHEVER IS GREATER.
- ② DECKS LOCATED 3 FEET OR GREATER FROM THE PROPERTY LINE MAY BE NONRATED CONSTRUCTION. DECKS LOCATED LESS THAN 3 FEET FROM THE PROPERTY LINE SHALL BE OF NONCOMBUSTIBLE OR MODIFIED HEAVY TIMBER CONSTRUCTION.

For SI: 1 inch = 25.4 mm.

**FIGURE R302.2.4.1**  
**DECK CONSTRUCTION LESS THAN THREE FEET FROM COMMON PROPERTY LINES**

**R302.2.4.2 Porch covers.** Fire-resistance-rated protection shall be provided for porch covers in accordance with the following:

1. Where one porch cover is adjacent to another porch cover and both are less than 3 feet (914 mm) from the common property line, a single 1-hour fire-resistance-rated privacy wall shall be provided for each porch cover. The privacy wall shall extend out to the furthest point where the porch covers are adjacent.
2. Where one porch cover abuts another adjacent porch cover at a common property line, either two 1-hour fire-resistance-rated walls or one “modified” 2-hour fire-resistance-rated common *townhouse* separation wall shall be provided. The *townhouse* separation wall or two individual walls shall extend out to the furthest point where both porch covers are adjacent. Abutting porch covers attached to structurally independent or dependent *townhouses* may share building elements as permitted by Section R302.2.7.
3. Where a porch cover is less than 3 feet (914 mm) from the common property line and there is no adjacent porch cover, a 1-hour fire-resistance-rated *exterior wall* shall be provided. The *exterior wall* shall extend to the furthest point of the porch cover.

The fire-resistance-rated walls required in Items 1 through 3 shall be continuous from the foundation to the roof sheathing where the roof/ceiling assembly is constructed in accordance with Section R302.2.6.1. Where the roof/ceiling assembly is not constructed in accordance with Section R302.1.6.1, the walls shall terminate in a parapet constructed in accordance with Section R302.2.5. Porch covers separated by a fire-resistance-rated privacy or *dwelling unit* separation wall need not be fire-resistance-rated.

**Exceptions:**

1. A privacy wall need not protect porch covers and the porch covers need not be fire-resistance-rated where each individual *townhouse* is provided with an automatic fire sprinkler system in accordance with NFPA 13D. Porch covers may be open construction or may be fully enclosed where ceilings are not less than 1-hour fire-resistance-rated construction.
2. A privacy wall need not protect a porch cover when the cover is constructed entirely of heavy timber construction. The heavy timber porch cover shall be open construction unless enclosed at the ceiling by not less than 1-hour fire-resistance-rated construction. Heavy timber porch cover components shall be provided according to the following:
  - 2.1. Supporting post for porch coverings shall be not less than 6 inches (153 mm) in nominal thickness.
  - 2.2. Joists or beams supporting porch coverings shall be not less than 4 inches (102 mm) in nominal thickness.
  - 2.3. Roof sheathing shall be not less than 2 inches (51 mm) in nominal thickness.
3. A privacy wall need not protect porch covers and the porch cover may be of nonfire-resistance-rated construction where they project not more than 2 feet (610 mm) from the face of the building.

4. A privacy wall need not protect porch covers and the porch cover may be of nonfire-resistance-rated construction where:

- 4.1. The *exterior wall* of the building perpendicular to the common property line is 1-hour fire-resistance-rated construction for a distance of not less than 4 feet (1220 mm) on each side of the common property line and there are no openings from the foundation to the underside of the porch roof sheathing. Where individual *townhouses* are stepped, no openings shall be allowed in the foundation less than 4 feet (1220 mm) from the property line.
- 4.2. A porch cover projects less than 4 feet (1220 mm) from the face of the building, the adjacent building walls and porch roof may be protected for a distance equal to the distance the porch cover projects.
- 4.3. The porch cover may be open-frame construction. When fully enclosed, the ceiling shall be of not less than 1-hour fire-resistance-rated construction (see Figure R302.2.4.2).
- 4.4. Enclosed *attic* space shall be separated at the common property line with either two 1-hour separation walls or one common “modified” 2-hour *townhouse* separation wall.
- 4.5. The parapet may be omitted on both open-framed and enclosed porch covers when the roof is sheathed with fire-retardant-treated plywood or <sup>5</sup>/<sub>8</sub>-inch (9.6 mm) Type X gypsum sheathing for a horizontal distance of not less than 4 feet (1220 mm) measured perpendicular to the common property line.

**R302.2.4.3 Exterior stairways.** Exterior stairs located less than 3 feet (914 mm) from a common property line shall be of fire-resistance-rated construction in accordance with the following, see Figure R302.2.4.3:

1. Structurally independent stairs may be connected at the common property line with common treads not less than 6 feet (1829 mm) in width of noncombustible or heavy timber construction.
2. Stairs serving an uncovered porch that serves not more than two individual *townhouses* may cross the common property line. Such stairs shall be not less than 44 inches (1118 mm) in width and shall be of noncombustible or heavy timber construction.
3. Stairs constructed using heavy timbers shall comply with this section and Figure R302.2.4.3. Heavy timber stair components supporting only the stair or landing dead load and the live load listed in Table R301.5 shall be constructed using the following minimum material thicknesses:
  - 3.1. Supporting posts for stairs shall be not less than 6 inches (153 mm) in nominal thickness.
  - 3.2. Stair stringers shall be not less than 4 inches (102 mm) in nominal thickness.
  - 3.3. Joists or beams supporting landings shall be not less than 4 inches (102 mm) in nominal thickness.



- 3.4. Stair treads and landing decking shall be not less than 6 inches (153 mm) in nominal thickness.

**Exceptions:**

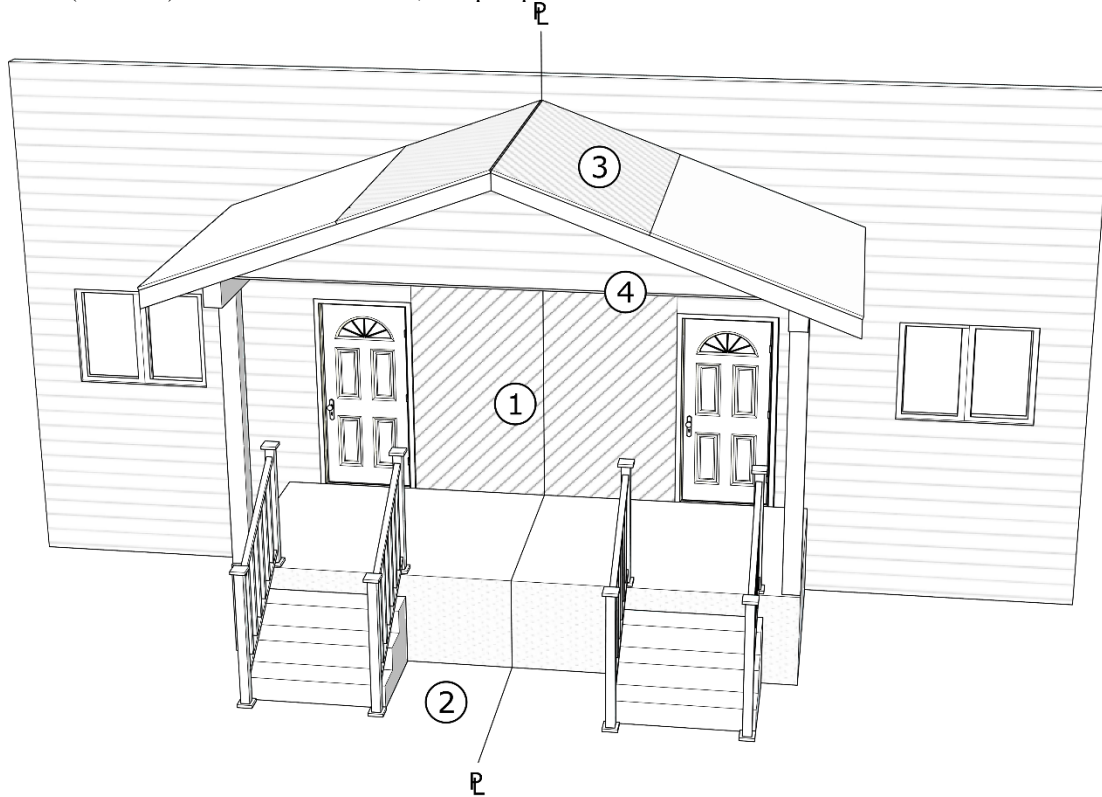
1. Stairs located less than 3 feet (914 mm) from a common property line need not be fire-resistance-rated when they are not under cover and not more than 30 inches (762 mm) above *grade*.
2. Stairs may be located less than 3 feet (914 mm) from a common property line when constructed using noncombustible materials.

**R302.2.5 Parapets for townhouses.** Where required, parapets shall be constructed for *townhouses* as an extension of *exterior walls* or common walls in accordance with the following:

1. Where roof surfaces adjacent to the wall or walls are at the same elevation, the parapet shall extend not less than 30 inches (762 mm) above the roof surfaces.
2. Where roof surfaces adjacent to the wall or walls are at different elevations and the higher roof is not more than 30 inches (762 mm) above the lower roof, the parapet

shall extend not less than 30 inches (762 mm) above the lower roof surface.

**Exception:** A parapet is not required in the preceding two cases where the *roof covering* complies with a minimum Class C rating as tested in accordance with ASTM E108 or UL 790 and the roof decking or sheathing is of noncombustible materials or fire-retardant-treated wood for a distance of 4 feet (1219 mm) on each side of the wall or walls, or one layer of 5/8-inch (15.9 mm) Type X gypsum board is installed directly beneath the roof decking or sheathing, supported by not less than nominal 2-inch (51 mm) ledgers attached to the sides of the roof framing members, for a distance of not less than 4 feet (1219 mm) on each side of the wall or walls and any openings or penetrations in the roof are not within 4 feet (1219 mm) of the common walls. Fire-retardant-treated wood shall meet the requirements of Sections R802.1.5 and R803.2.1.2.



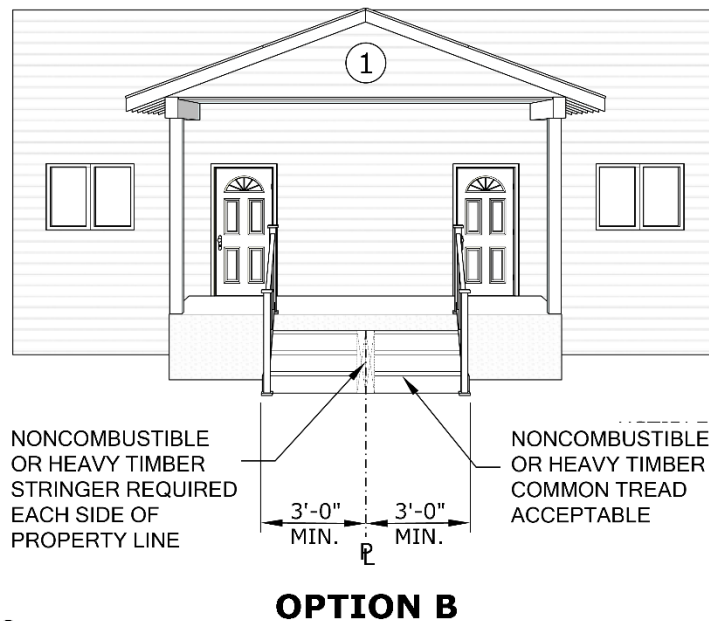
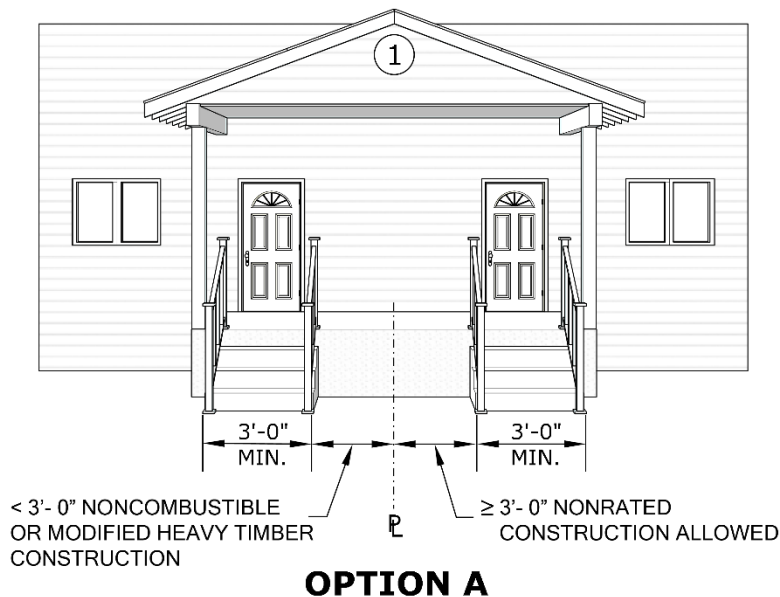
**NOTES**

- ① ONE-HOUR WALL, WITHOUT OPENINGS, CONTINUING FROM COMMON PROPERTY LINE, EXTENDING NOT LESS THAN 4 FEET PERPENDICULARLY FROM THE PROPERTY LINE, ACROSS THE FRONT OF THE DWELLING UNIT. THIS WALL IS TO EXTEND FROM THE FOUNDATION OF THE DWELLING UNIT TO THE UPPERMOST ROOF SHEATHING OF THE PORCH.
- ② STAIRWAYS THAT ARE LESS THAN 3 FEET FROM THE PROPERTY LINE SHALL BE OF ONE-HOUR, MODIFIED HEAVY TIMBER, OR NONCOMBUSTIBLE CONSTRUCTION (SEE FIGURE R302.2.4.3).
- ③ ROOF CONSTRUCTION SHALL BE AS PROPERTY LINE CONSTRUCTION.
- ④ IF A PORCH SOFFIT IS PROVIDED, THE SOFFIT SHALL BE OF 5/8 INCH TYPE X GYPSUM BOARD SHEATHING WITHOUT OPENINGS, FOR ITS FULL DEPTH AND WIDTH.

For SI: 1 inch = 25.4 mm.

**FIGURE R302.2.4.2**  
**COVERED PORCH AT COMMON PROPERTY LINE**





NOTES:

- ① FOR UNCOVERED PORCHES SERVING NOT MORE THAN TWO UNITS, A COMMON STAIR MAY BE PROVIDED WITH A WIDTH OF NOT LESS THAN 44 INCHES AND SHALL BE OF NONCOMBUSTIBLE OR HEAVY TIMBER CONSTRUCTION

For SI: 1 inch = 25.4 mm.

**FIGURE R302.2.4.3**  
**EXTERIOR STAIRWAY**

3. A parapet is not required where roof surfaces adjacent to the wall or walls are at different elevations and the higher roof is more than 30 inches (762 mm) above the lower roof. The common wall construction from the lower roof to the underside of the higher roof deck shall have not less than a 1-hour fire-resistance rating. The wall shall be rated for exposure from both sides. A parapet is not required for roofs that comply with Section R302.2.6.

**R302.2.5.1 Parapet construction.** Parapets shall have the same fire-resistance rating as that required for the supporting wall or walls. On any side adjacent to a roof surface, the parapet shall have noncombustible faces for the uppermost 18

inches (457 mm), to include counterflashing and coping materials. Where the roof slopes toward a parapet at slopes greater than 2 units vertical in 12 units horizontal (16.7-percent slope), the parapet shall extend to the same height as any portion of the roof within a distance of 3 feet (914 mm), and the height shall be not less than 30 inches (762 mm).

**R302.2.6 Townhouse roof construction.** In addition to the requirements of Chapter 8 of this code, townhouses shall comply with this section for fire-resistance-rated roof/ceiling construction, roof/ceiling penetrations, and cricket construction. Projections of eaves, cornices, and similar components shall comply with Section R302.2.6.4.

**R302.2.6.1 Roof/ceiling assemblies.** Roof/ceiling assemblies intersecting fire-resistance-rated *exterior walls* may be of nonrated construction. Roof/ceiling assemblies intersecting common fire-resistance-rated individual *townhouse* unit separation walls and privacy walls associated with porch covers and decks shall comply with Section R302.2.5 or be constructed in accordance with the following:

1. A roof/ceiling assembly with framing oriented perpendicular to a 1-hour wall shall be constructed in accordance with Figure R302.2.1(1). The roof sheathing shall be either fire-retardant-treated plywood or have not less than  $\frac{5}{8}$ -inch (15.9 mm) Type X gypsum board installed under the standard plywood sheathing for a horizontal distance of not less than 4 feet (1220 mm) from the common property line.
2. A roof/ceiling assembly with framing oriented parallel to a 1-hour wall shall be constructed in accordance with Figure R302.2.1(2).
3. A roof/ceiling assembly with framing oriented perpendicular to a “modified” 2-hour common wall shall be constructed in accordance with Figure R302.2.1(3). The roof sheathing shall be either fire-retardant-treated plywood or have not less than  $\frac{5}{8}$ -inch (15.9 mm) Type X gypsum board installed under the standard plywood roof sheathing for a horizontal distance of not less than 4 feet (1220 mm) from the common property line.
4. A roof/ceiling assembly with framing oriented parallel to a “modified” 2-hour common wall shall be constructed in accordance with Figure R302.2.1(4).
5. As an alternate to Items 1 through 4, the entire ceiling of the upper story shall be protected throughout with two layers of  $\frac{5}{8}$ -inch (15.9 mm) Type X gypsum board as required for a 1-hour fire-resistance-rated roof/ceiling assembly. Where roof framing is parallel to a common *townhouse* separation wall, a 1-hour attic enclosure “mushroom” may be constructed according to Figure R302.2.6.1 and the two layers of  $\frac{5}{8}$ -inch (15.9 mm) Type X gypsum board on the ceiling may terminate at the outside vertical edge of the “mushroom.”

**R302.2.6.2 Roof/ceiling penetrations.** Membrane penetrations of the fire-resistance-rated ceiling required by Section R302.2.6.1 shall be protected by an *approved* penetration firestop system in accordance with Sections R302.4.1.1 and R302.4.1.2. Through-penetrating items shall be enclosed within a shaft constructed in accordance with the *Building Code*.

Skylights, mechanical and plumbing vents, attic vents, solar collectors and similar penetrations of the roof are not permitted within 4 feet (1220 mm) of the common property line.

**Exceptions:**

1. Chimneys may penetrate roofs less than 4 feet (1220 mm) from a common property line when a spark arrestor is installed at the terminus. Where factory-built chimneys are located less than 4 feet (1220 mm) from a common property line, they shall be enclosed within 1-hour fire-resistance-rated shafts

constructed in accordance with the *Building Code*. Such shafts shall extend from where the factory-built chimney first penetrates a fire-resistance-rated wall or ceiling and shall continue to the uppermost termination of the chimney.

2. Unprotected factory-built chimneys and other unprotected penetrations are allowed less than 4 feet (1220 mm) from common property lines when parapets are provided in accordance with Section R302.2.5.

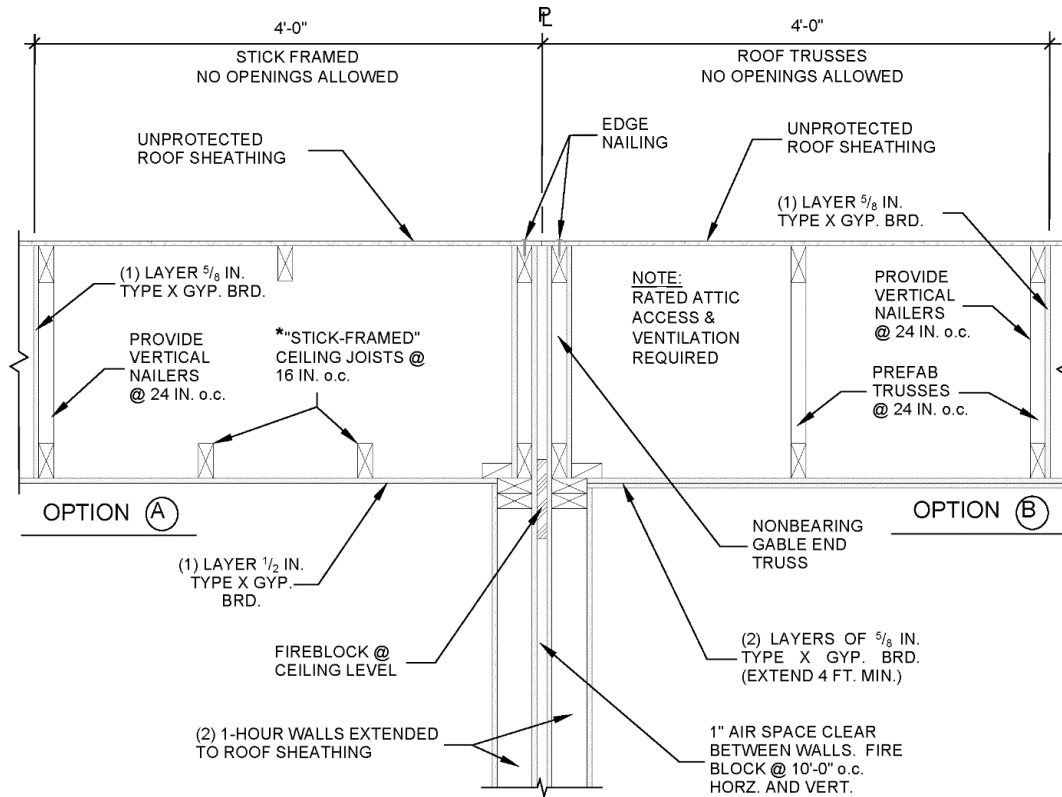
**R302.2.6.3 Cricket construction.** Where crickets are installed, one of the following methods of construction shall be used.

1. Where crickets are 30 inches or less in height, the common fire-resistant *townhouse* separation wall may terminate at the underlying roof sheathing. The underlying roof sheathing shall be protected with either fire-retardant-treated plywood or have not less than  $\frac{5}{8}$ -inch (15.9 mm) Type X gypsum board installed under the standard plywood roof sheathing for the full extent of the cricket, but not less than 4 feet measured horizontally from the common property line. There shall be no openings in the roof sheathing under the cricket [see Figures R302.2.6.3(1) and R302.2.6.3(2)].
2. Where crickets greater than 30 inches in height are provided, the common fire-resistant *townhouse* separation wall shall extend to the cricket roof sheathing, and the cricket roof sheathing shall be protected with either fire-retardant-treated plywood or have not less than  $\frac{5}{8}$ -inch (15.9 mm) Type X gypsum board installed under the standard plywood roof sheathing for a horizontal distance of not less than 4 feet (1220 mm) on each side of common property line. There shall be no openings in the cricket sheathing [see Figure R302.2.6.3(3)].

**R302.2.6.4 Eaves, cornices and similar projections.** Projections located less than 3 feet (914 mm) from a common property line shall be in accordance with this section. Structural projections such as enclosed eaves and cornices located less than 3 feet (914 mm) from a common property line shall be constructed in accordance with Table R302.2.6.4. Projections within 3 feet (914 mm) of an exterior common property line shall be in accordance with Section R302.1.

**R302.2.7 Structural design approach.** *Townhouse* structures shall be permitted to be designed as structurally dependent structures, structurally independent structures or a combination of both. See Figure R302.2.7.

**R302.2.7.1 Lateral force analysis.** A lateral force analysis shall be submitted at the time of application when *townhouses* or the portions of *townhouses* are designed in accordance with accepted engineering practice as either structurally independent or structurally dependent. *Townhouses* designed using only the prescriptive provisions of this code are exempt from this requirement. Building components providing lateral resistance shall be identified and detailed in the *construction documents*.

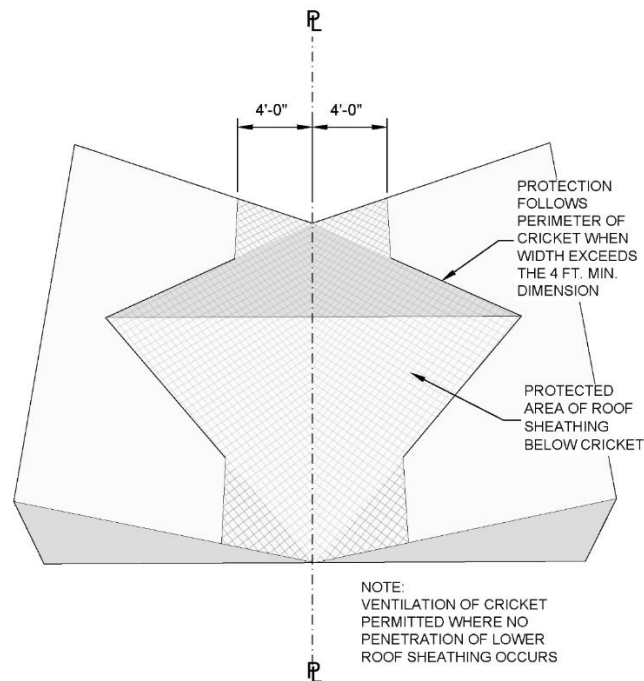


\* "STICK-FRAMED" ROOFS WITH CEILING JOISTS @ 24 IN. o.c. SHALL HAVE (2) LAYERS OF 5/8 IN. TYPE X GYP. BRD. AT CEILING

NOTE: DETAIL SIMILAR AT "MODIFIED" 2-HR PROPERTY LINE FIREWALL SEE FIGURE R302.2.1(4) FOR ADDITIONAL INFORMATION

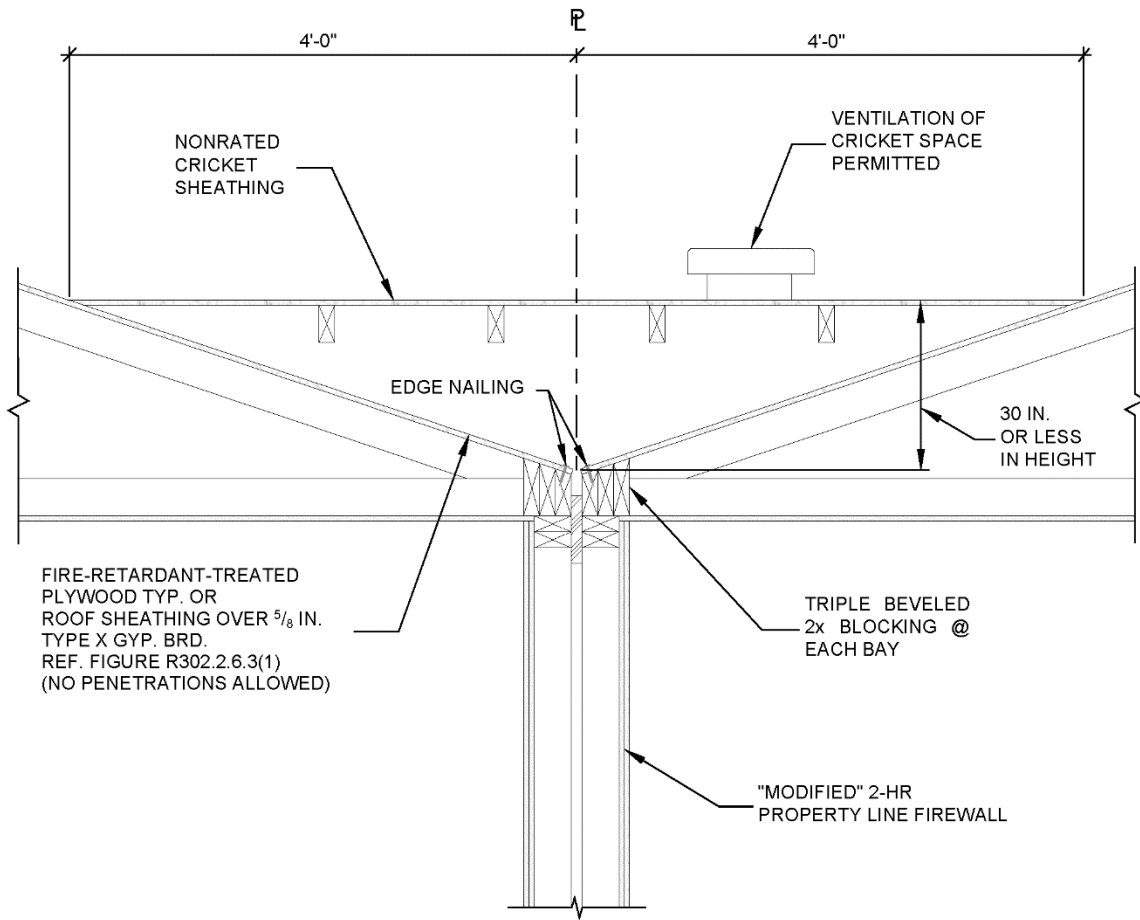
For SI: 1 inch = 25.4 mm.

**FIGURE R302.2.6.1**  
**FIRE-RESISTANCE RATED ROOF/CEILING CONSTRUCTION-"MUSHROOM" ATTIC ENCLOSURE FRAMING PARALLEL TO COMMON PROPERTY LINE**



For SI: 1 inch = 25.4 mm.

**FIGURE R302.2.6.3(1)**  
**UNRATED CRICKET LESS OR EQUAL TO 30 INCHES**



- NOTES:**
1. DETAIL IS SIMILAR FOR (2) 1-HR FIREWALL OPTION
  2. SEE FIGURE R302.2.1(3) FOR ADDITIONAL INFORMATION

For SI: 1 inch = 25.4 mm.

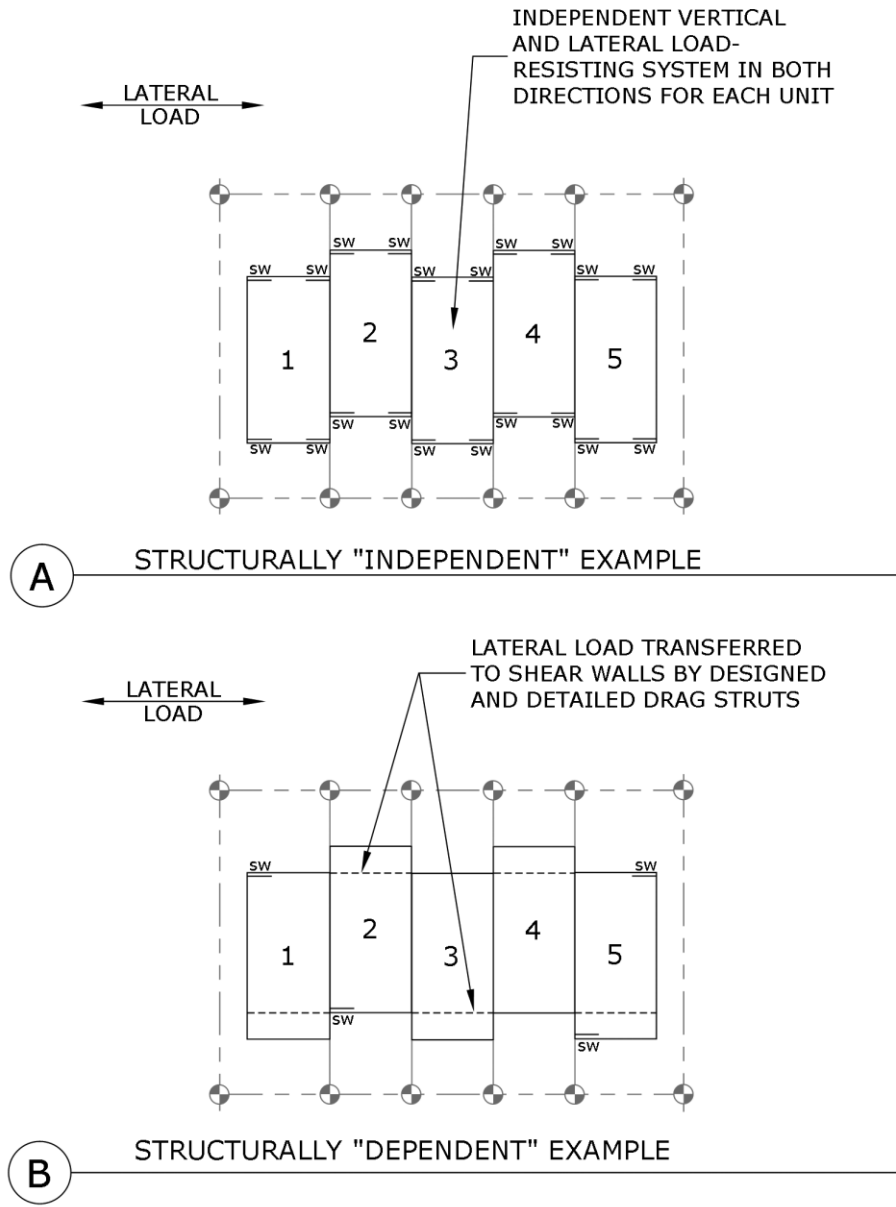
**FIGURE R302.2.6.3(2)**  
**UNRATED CRICKET LESS THAN OR EQUAL TO 30 INCHES**

**TABLE R302.2.6.4**  
**STRUCTURAL PROJECTIONS LOCATED LESS THAN 3 FEET OF ANY PROPERTY LINE**

EAVES, RAKES, CORNICES & SIMILAR PROJECTIONS <sup>a</sup>	RELATIONSHIP OF FASCIA/BARGE TO PROPERTY LINE	EAVE VENTILATION PERMITTED	MAXIMUM LENGTH OF PROJECTION	PARAPET OR ROOF PROTECTION REQUIRED	MAXIMUM PROJECTION LENGTH BEYOND PROPERTY LINE	1-HOUR-RATED PROTECTION REQUIRED
Enclosed with roof framing perpendicular to property line	Parallel	No	12" maximum	Yes	12" maximum	Yes
Unenclosed with roof framing perpendicular to property line	Parallel	No	12" maximum	Yes	12" maximum	No
Enclosed with roof framing parallel to property line	Perpendicular	No	24" maximum	No	12" maximum	Yes
Unenclosed with roof framing parallel to property line	Perpendicular	Yes	24" maximum	No	12" maximum	No

For SI: 1 inch = 25.4 mm.

- a. Does not apply to exterior balconies.



SW = Possible shear wall location

For SI: 1 inch = 25.4 mm.

**FIGURE R302.2.7  
STRUCTURAL DESIGN APPROACH**

**R302.2.7.2 Structural independence.** Townhouses designed and constructed as structurally independent in accordance with the prescriptive provisions of this code shall be permitted to share the following elements:

**Exceptions:**

1. Foundations supporting exterior walls or common walls and monolithic grade beam footings.
2. Structural roof and wall sheathing from each unit fastened to the common wall framing. These elements shall be edge fastened at each side of the common property line.
3. Nonstructural wall and roof coverings.
4. Flashing at the termination of roof coverings over common wall.
5. Modified 2-hour or a common 2-hour fire-

resistance-rated wall as provided in Section R302.2.

6. Soffit enclosures.
7. Cricket framing.
8. Roof covering
9. Gutters and downspouts.
10. Porches and stairs.
11. Porch coverings.

Portions of structurally independent townhouses designed in accordance with accepted engineering practice shall provide independent vertical and lateral load-resisting systems for such designed portions.

**R302.2.7.3 Structural dependence.** Structurally dependent townhouses shall be designed in accordance with Section R301.1.3.



## R302.2.8 Fire-resistance-rated walls and cantilevers.

**R302.2.8.1 Location on property.** *Townhouse exterior walls*, privacy walls, common *townhouse* separation walls, exterior *stairways*, porches, porch coverings, decks, roofs and projections located less than 3 feet (914 mm) from a common or exterior property line shall be fire-resistance-rated and constructed in accordance with this section.

**Exception:** Walls oriented perpendicular to a common property line need not be fire-resistance-rated construction and may have unprotected openings.

**R302.2.8.1.1 Townhouse wall construction.** *Exterior walls*, privacy walls, and common *townhouse* separation walls shall be parallel to the common property line and be of fire-resistance-rated construction. Such walls shall be of the types listed in Section R302.2 or other *listed*, tested assemblies that provide an equivalent fire-resistance rating.

**R302.2.8.2 Cantilevered living areas.** Cantilevered living areas shall be protected by one of the following methods:

1. Where one cantilever is adjacent to another cantilever, and both are less than 3 feet (914 mm) from the common property line, a single 1-hour fire-resistance-rated *townhouse* separation wall shall be provided for each cantilever. The *townhouse* separation walls shall extend to the furthest point where the cantilevers are adjacent.
2. Where one cantilever abuts another adjacent cantilever at a common property line, either two 1-hour fire-resistance-rated walls or one "modified" 2-hour fire-resistance-rated common *townhouse* separation wall shall be provided. The *townhouse* separation wall shall extend to the furthest point where both cantilevers are adjacent.
3. Where there is one cantilever within 3 feet of the common property line and no adjacent cantilever less than 3 feet (914 mm) from the common property line, a 1-hour fire-resistance-rated *exterior wall* shall be provided. The *exterior wall* shall extend to the furthest point of the cantilever.

The fire-resistance-rated walls required in Items 1 through 3 shall be continuous from the foundation to the roof sheathing when the roof/ceiling assembly is constructed in accordance with Section R302.2.6.1. When the roof/ceiling assembly is not constructed in accordance with Section R302.2.6.1, the wall shall terminate in a parapet constructed in accordance with Section R302.2.5.

### Exceptions:

1. Cantilevers may be unprotected when each individual *townhouse* is provided with a fire suppression system in accordance with NFPA 13D.
2. The extension of fire-resistance-rated walls beneath the cantilever may be omitted, provided that the *exterior wall* perpendicular to the common property line is 1-hour fire-resistance-rated construction for a distance of 4 feet (1240 mm) on each side of the common property line from the foundation to the bottom of the cantilever. Foundation vents shall not be located less than 4 feet (1240 mm) from the common property line. The soffit area under the

cantilever shall have not less than 1-hour fire-resistance-rated protection for a distance of not less than 4 feet (1240 mm) on each side of the common property line. Where the cantilever projects less than 4 feet (1240 mm) from the face of the building, the prohibition of openings and the fire-resistance-rated wall and soffit construction perpendicular to the common property line need only extend for a distance equal to the projection of the cantilever.

**R302.2.8.3 Openings.** Openings in fire-resistant *exterior walls*, privacy walls and individual *townhouse* separation walls are not permitted.

**R302.2.9 Townhouse dwelling unit and garage separations.** *Townhouses* shall be separated from attached garages in accordance with Section R302.6.

**R302.2.10 Townhouse interior duct and vent chase penetrations of floor/ceiling assemblies.** Gas vents, ducts, piping and factory-built chimneys that extend through not more than two floors need not be enclosed, provided the openings around the penetrations are fire-stopped at each floor.

**Exception:** Type BW gas vents installed in accordance with their listing.

**R302.2.11 Townhouse foundation and footing construction.** A single footing and foundation wall may be designed and constructed for common property line walls in accordance with this section, Figure R302.2.11 and Chapter 4. Through penetrations of the foundation across a common property line are not permitted. If required by local conditions, footing drains, rain drains and low point under-floor drainage shall be provided and drained to an *approved* location.

**R302.2.12 Townhouse roof coverings.** In addition to the requirements of Chapter 9, structurally independent *townhouses* shall be provided with a minimum Class C *roof covering* and structurally dependent *townhouses* shall be provided with a minimum Class B *roof covering*.

### Exceptions:

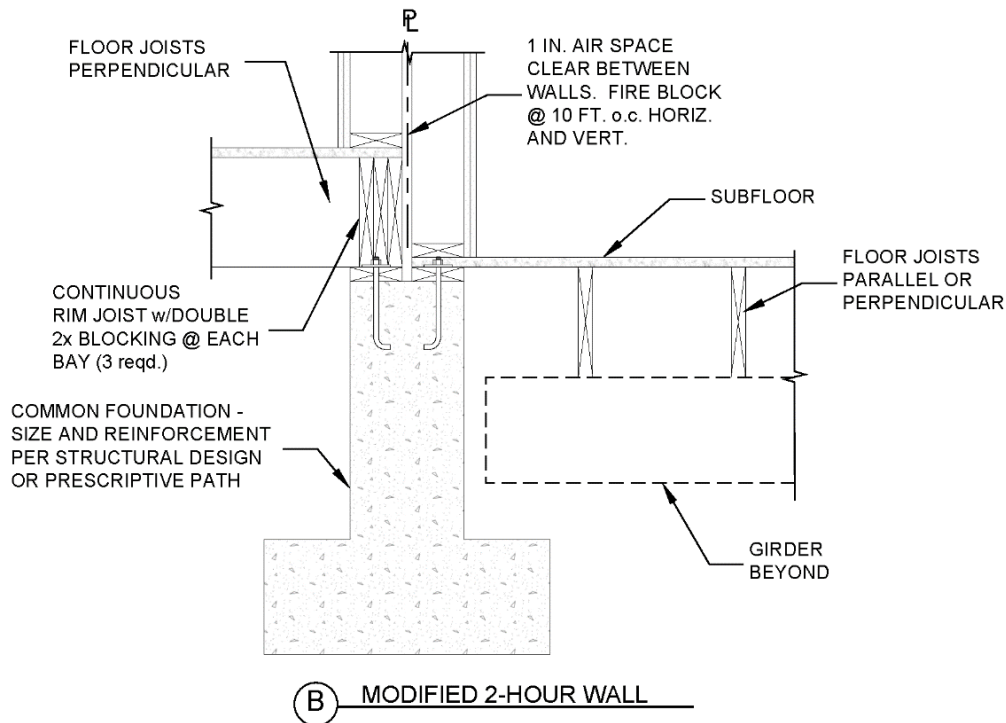
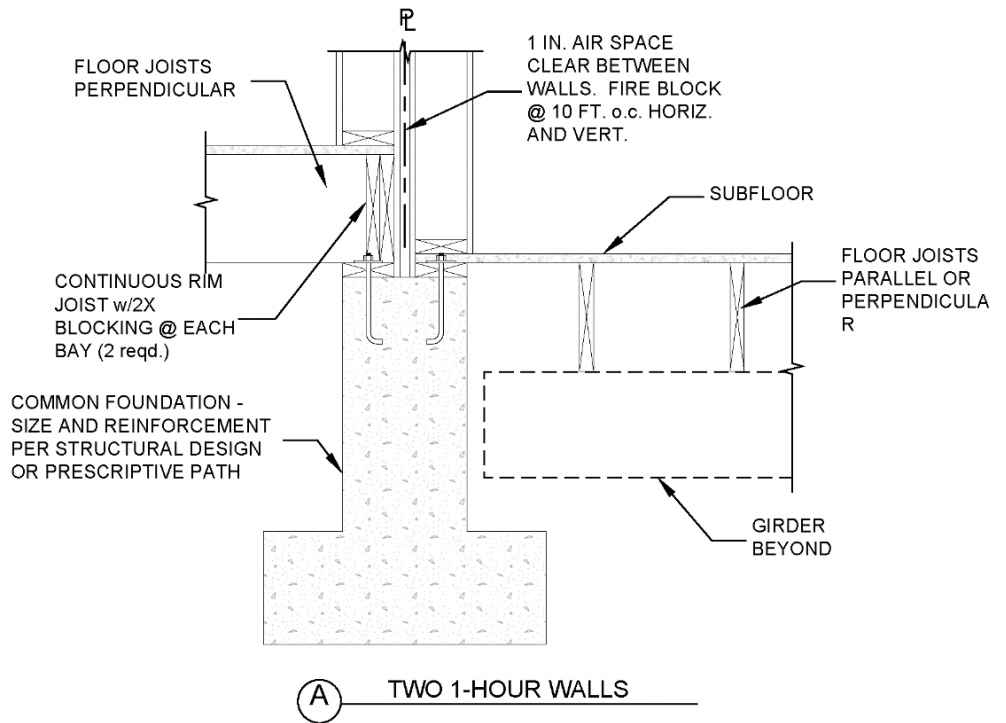
1. Structurally dependent *townhouses* may use Class C *roof coverings* when all of the following conditions are met:
  - 1.1. The *townhouses* are not more than two stories in height.
  - 1.2. The *townhouses* do not have more than 6,000 square feet (557 m<sup>2</sup>) of projected roof area.
  - 1.3. There is not less than 3 feet (914 mm) from the extremity of the roof to the exterior property line or an assumed property line on all sides except for street fronts.
2. *Roof coverings* for *townhouses* located in areas determined by the *municipality* to be "Wildfire Hazard Zones," shall be in accordance with Section R327.

**R302.2.13 Townhouse dwelling unit egress.** Each individual *townhouse* shall have a means of egress system in accordance with Section R311. Such means of egress system shall be a structurally independent exit way, having a clear width of not less than 3 feet.



**R302.2.14 Townhouse adaptability/accessibility.** Where the project includes four or more contiguous individual townhouses, one or more of which is single story, the requirements of the Fair Housing Act and Chapter 11 of the *Building Code* apply. Ground-level, single-story townhouses

shall be made *accessible* in accordance with the requirements for Group R-3 occupancies in Chapter 11 of the *Building Code*. Any common-use facilities such as a clubhouse or management office shall be made accessible in accordance with Chapter 11 of the *Building Code*.



**FIGURE R302.2.11**  
**FOUNDATION AND FOOTING CONSTRUCTION**

## Two-family dwellings.

**R302.3.2 Property line separation.** Where a two-family dwelling is separated by a real property line, dwelling unit separation shall be provided in accordance with one of the following:

1. Townhouse provisions of Section R302.2, as applicable.
2. Two individual wall assemblies having not less than a 1-hour fire-resistance rating where tested in accordance with ASTM E119 or UL 263.
3. Other approved methods of equivalent fire resistance.

## Dwelling unit rated penetrations.

**R302.4 Dwelling unit rated penetrations.** Penetrations of wall or floor-ceiling assemblies required to be fire-resistance rated in accordance with Section R302.2 or R302.3 shall be protected in accordance with this section.

**R302.4.1 Through-penetrations.** Through-penetrations in fire-resistant exterior walls, privacy walls and individual or common townhouse separation walls are not permitted in townhouses. In other than townhouses, through penetrations of fire-resistance-rated wall or floor assemblies shall comply with Section R302.4.1.1 or R302.4.1.2.

**Exception:** In other than townhouses, where the penetrating items are steel, ferrous or copper pipes, tubes or conduits, the annular space shall be protected as follows:

- In concrete or masonry wall or floor assemblies, concrete, grout or mortar shall be permitted where installed to the full thickness of the wall or floor assembly or the thickness required to maintain the fire-resistance rating, provided that both of the following are complied with:
  - The nominal diameter of the penetrating item is not more than 6 inches (152 mm).
  - The area of the opening through the wall does not exceed 144 square inches (92 900 mm<sup>2</sup>).
- The material used to fill the annular space shall prevent the passage of flame and hot gases sufficient to ignite cotton waste where subjected to ASTM E119 or UL 263 time temperature fire conditions under a positive pressure differential of not less than 0.01 inch of water (3 Pa) at the location of the penetration for the time period equivalent to the fire-resistance rating of the construction penetrated.

**R302.4.1.1 Fire-resistance-rated assembly.** Penetrations shall be installed as tested in the approved fire-resistance-rated assembly.

**R302.4.1.2 Penetration firestop system.** Penetrations shall be protected by an approved penetration firestop system installed as tested in accordance with ASTM E814 or UL 1479, with a positive pressure differential of not less than 0.01 inch of water (3 Pa) and shall have an F rating of not less than the required fire-resistance rating of the wall or floor-ceiling assembly penetrated.

**R302.4.2 Membrane penetrations.** Membrane penetrations in townhouses shall comply with this section and Section R302.4.2.1. Membrane penetrations shall comply with Section R302.4.1. Where walls are required to have a fire-resistance rating, recessed fixtures shall be installed so that the required fire-resistance rating will not be reduced.

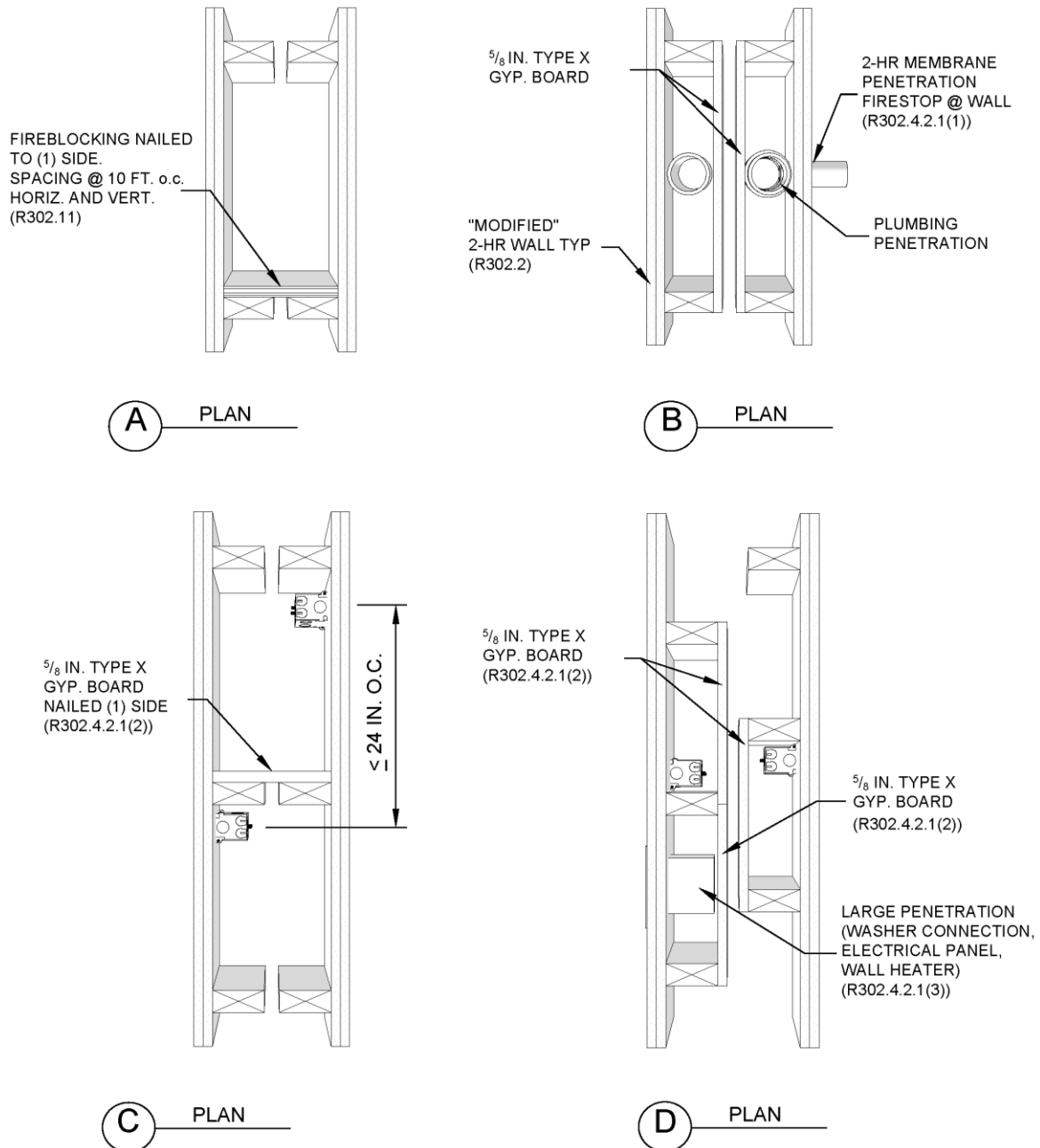
### Exceptions:

- Membrane penetrations of not more than 2-hour fire-resistance-rated walls and partitions by steel electrical boxes that do not exceed 16 square inches (0.0103 m<sup>2</sup>) in area provided that the aggregate area of the openings through the membrane does not exceed 100 square inches (0.0645 m<sup>2</sup>) in any 100 square feet (9.29 m<sup>2</sup>) of wall area. The annular space between the wall membrane and the box shall not exceed 1/8 inch (3.1 mm). Such boxes on opposite sides of the wall shall be separated by one of the following:
  - By a horizontal distance of not less than 24 inches (610 mm) where the wall or partition is constructed with individual noncommunicating stud cavities.
  - By a horizontal distance of not less than the depth of the wall cavity where the wall cavity is filled with cellulose loosefill, rockwool or slag mineral wool insulation.
  - By solid fireblocking in accordance with Section R302.11.
  - By protecting both boxes with listed putty pads.
  - By other listed materials and methods.
- Membrane penetrations by listed electrical boxes of any materials provided that the boxes have been tested for use in fire-resistance-rated assemblies and are installed in accordance with the instructions included in the listing. The annular space between the wall membrane and the box shall not exceed 1/8 inch (3.1 mm) unless listed otherwise. Such boxes on opposite sides of the wall shall be separated by one of the following:
  - By the horizontal distance specified in the listing of the electrical boxes.
  - By solid fireblocking in accordance with Section R302.11.
  - By protecting both boxes with listed putty pads.
  - By other listed materials and methods.
- The annular space created by the penetration of a fire sprinkler provided that it is covered by a metal escutcheon plate.
- Ceiling Membrane penetrations by listed luminaires or by luminaires protected with listed materials that have been tested for use in fire-resistance-rated assemblies and are installed in accordance with the instructions included in the listing.

**R302.4.2.1 Additional townhouse membrane penetration requirements.** Membrane penetrations in townhouse fire-resistance-rated exterior walls, privacy walls and individual townhouse separation walls are allowed as provided in Section R302.2.

**Exceptions:** Membrane penetrations in townhouse fire-resistance-rated walls:

1. Shall be protected with a listed penetration firestop system rated for not less than 2 hours when the penetration is in a common "modified" 2-hour fire-resistance-rated wall.
2. May have the minimum separation distance of 24 inches (610 mm) between electrical boxes reduced when installed in accordance with Figure R302.4.2.1, Details C and D.
3. For large boxes such as washer connections, electrical panels and wall heaters may be installed where the fire protection extends behind the box in accordance with Figure R302.4.2.1, Details B and D.
4. Stair stringers shall be in accordance with Section R302.2.4.



**NOTE:** THROUGH-PENETRATIONS ARE PROHIBITED IN TOWNHOUSE STRUCTURES BY SECTION R302.4.1. TOWNHOUSE MEMBRANE PENETRATIONS SHALL COMPLY WITH SECTIONS R302.4.2, R302.4.2.1 AND FIGURE R302.4.2.1, AS APPLICABLE.

**FIGURE R302.4.2.1**  
**MEMBRANE PENETRATIONS FOR MODIFIED 2-HOUR WALLS**

## Toilet and bathing facilities

### R303.3 Toilet and bathing facilities ventilation.

**R303.3.1 Rooms with bathing or spa facilities.** Any room with a bathtub, shower or spa facility shall be provided with mechanical ventilation designed and installed in accordance with Section M1505.5.

**R303.3.2 Rooms without bathing or spa facilities.** Water closet compartments or toilet rooms without bathtub, shower or spa facilities shall be provided with an aggregate glazing area of not less than 3 square feet (0.3 m<sup>2</sup>), one-half of which shall be openable.

**Exception:** The glazed areas shall not be required where artificial light and a mechanical ventilation system are provided. The minimum ventilation rates shall be in accordance with Table M1505.5.

## Mechanical ventilation.

**R303.4 Mechanical ventilation.** Each dwelling unit shall be provided with whole-house mechanical ventilation in accordance with Section M1505.4.

## Emergency escape and rescue openings (EERO).

**R310.1 Emergency escape and rescue opening required.** Basements, habitable attics and every sleeping room shall have not less than one operable emergency escape and rescue opening. Where basements contain one or more sleeping rooms, an emergency escape and rescue opening shall be required in each sleeping room. Emergency escape and rescue openings shall open directly into a public way, or to a yard or court that opens to a public way.

### Exceptions:

1. Storm shelters and basements used only to house mechanical equipment not exceeding a total floor area of 200 square feet (18.58 m<sup>2</sup>).
2. Where the dwelling or townhouse is equipped with an automatic sprinkler system installed in accordance with NFPA 13D, sleeping rooms in basements shall not be required to have emergency escape and rescue openings provided that the basement has one of the following:
  - 2.1. One means of egress complying with Section R311 and one emergency escape and rescue opening.
  - 2.2. Two means of egress complying with Section R311.

**R310.1.1 Operational constraints and opening control devices.** Emergency escape and rescue openings shall be operational from the inside of the room without the use of keys, tools or special knowledge. Window opening control devices on windows serving as a required emergency escape and rescue opening shall comply with ASTM F2090.

**R310.2 Emergency escape and rescue openings.** Emergency escape and rescue openings shall have minimum dimensions as specified in this section.

**R310.2.1 Minimum opening area.** Emergency escape and rescue openings shall have a net clear opening of not less than 5.7 square feet (0.530 m<sup>2</sup>). The net clear opening dimensions required by this section shall be obtained by the normal operation of the emergency escape and rescue opening from the inside. The net clear height of the opening shall be not less than 24 inches (610 mm) and the net clear width shall be not less than 20 inches (508 mm).

**Exception:** Grade floor openings or below-grade openings shall have a net clear opening area of not less than 5 square feet (0.465 m<sup>2</sup>).

**R310.2.2 Window sill height.** Where a window is provided as the emergency escape and rescue opening, it shall have a sill height of not more than 44 inches (1118 mm) measured from the finished floor to the bottom of the clear opening. Where the sill height is below grade, it shall be provided with a window well in accordance with Section R310.2.3.

**R310.2.3 Window wells.** The horizontal area of the window well shall be not less than 9 square feet (0.9 m<sup>2</sup>), with a horizontal projection and width of not less than 36 inches (914 mm). The area of the window well shall allow the emergency escape and rescue opening to be fully opened.

**Exception:** The ladder or steps required by Section R310.2.3.1 shall be permitted to encroach not more than 6 inches (152 mm) into the required dimensions of the window well.

**R310.2.3.1 Ladder and steps.** Window wells with a vertical depth greater than 44 inches (1118 mm) shall be equipped with a permanently affixed ladder or steps usable with the window in the fully open position. Ladders or steps required by this section shall not be required to comply with Section R311.7. Ladders or rungs shall have an inside width of not less than 12 inches (305 mm), shall project not less than 3 inches (76 mm) from the wall and shall be spaced not more than 18 inches (457 mm) on center vertically for the full height of the window well.

**R310.2.3.2 Drainage.** Window wells shall be designed for proper drainage by connecting to the building's foundation drainage system required by Section R405.1 or by an approved alternative method.

**Exception:** A drainage system for window wells is not required where the foundation is on well-drained soil or sand-gravel mixture soils in accordance with the United Soil Classification System, Group I Soils, as detailed in Table R405.1.

**R310.2.4 Emergency escape and rescue openings under decks, porches and similar projections.** Emergency escape and rescue openings shall be permitted to be installed under decks, porches and similar projections, provided that the location of the projection allows the emergency escape and rescue openings to be fully opened and provides a path not less than 36 inches (914 mm) in height to a yard or court.

**R310.2.5 Emergency escape and rescue openings above lower roof surfaces.** Emergency escape and rescue openings located above a portion of roof surface below shall be provided with an unobstructed path, not less than 36 inches (914 mm) in width, from the vertical plane of the opening to the nearest edge of the lower roof, as practicable.



**R310.2.6 Replacement windows.** Replacement windows installed in buildings meeting the scope of this code shall be exempt from the maximum sill height requirements of Section R310.2.2 and the requirements of Section R310.2.1, provided that the replacement window meets the following conditions:

1. The replacement window is the manufacturer's largest standard size window that will fit within the existing frame or existing rough opening. The replacement window is of the same operating style as the existing window or a style that provides for an equal or greater window opening area than the existing window.
2. The replacement window is not part of a change of occupancy [or use](#).

**R310.3 Emergency escape and rescue doors.** Where a door is provided as the required emergency escape and rescue opening, it shall be a side-hinged door or a slider. Where the opening is below the adjacent grade, it shall be provided with an area well.

**R310.3.1 Minimum door opening size.** The minimum net clear height opening for any door that serves as an emergency and escape rescue opening shall be in accordance with Section R310.2.1.

**R310.3.2 Area wells.** Area wells shall have a width of not less than 36 inches (914 mm). The area well shall be sized to allow the emergency escape and rescue door to be fully opened.

**R310.3.2.1 Ladder and steps.** Area wells with a vertical depth greater than 44 inches (1118 mm) shall be equipped with a permanently affixed ladder or steps usable with the door in the fully open position. Ladders or steps required by this section shall not be required to comply with Section R311.7. Ladders or rungs shall have an inside width of not less than 12 inches (305 mm), shall project not less than 3 inches (76 mm) from the wall and shall be spaced not more than 18 inches (457 mm) on center vertically for the full height of the exterior stairwell.

**R310.3.2.2 Drainage.** Area wells shall be designed for proper drainage by connecting to the building's foundation drainage system required by Section R405.1 or by an *approved* alternative method.

**Exception:** A drainage system for area wells is not required where the foundation is on well-drained soil or sand-gravel mixture soils in accordance with the United Soil Classification System, Group I Soils, as detailed in Table R405.1.

## Stairways.

**R311.7 Stairways.** [Where required by this code or otherwise provided, stairways shall comply with this section.](#)

**Exception:** [Stairways not within or directly serving a regulated building, patio, porch or deck.](#)

## Ramps.

**R311.8 Ramps.** [Where required by this code or otherwise provided, ramps shall comply with this section.](#)

**Exception:** [Ramps not within or directly serving a regulated building, patio, porch or deck.](#)

## Window fall protection.

**R312.2.1 Window sills.** In *dwelling units*, where the top of the sill of an operable window opening is located less than 24 inches (610 mm) above the finished floor and greater than 72 inches (1829 mm) above the finished *grade* or *flat surface* [not less than 36 inches \(914 mm\) in width](#) below on the exterior of the building, the operable window shall comply with one of the following:

1. Operable window openings will not allow a 4-inch diameter (102 mm) sphere to pass through where the openings are in their largest opened position.
2. Operable windows are provided with window fall prevention devices that comply with ASTM F2090.
3. Operable windows are provided with window opening control devices that comply with Section R312.2.2.

## Moisture control.

**R318.1 Vapor retarders.** In all framed walls, floors and roof/ceilings that are elements of the building thermal envelope, a Class II vapor retarder shall be installed on the warm-in-winter side of the insulation.

### Exceptions:

1. In construction where moisture or freezing will not damage the materials.
2. Where the framed cavity or space is ventilated to allow moisture to escape.
3. [Class III vapor retarders shall be permitted for framed walls where either of the following conditions apply:](#)
  - 3.1. [Vented cladding is installed over wood structural panels.](#)
  - 3.2. [Continuous air impermeable insulation is applied on exterior above-grade wall surfaces.](#)

**R318.2 Moisture content.** Prior to the installation of interior finishes, the *building official* shall be notified in writing by the general contractor that all moisture-sensitive wood framing members used in construction have a moisture content of not more than 19 percent of the weight of dry wood framing members.

## Solar energy systems.

**R324.1 General.** Solar energy systems shall comply with the provisions of this section.

**R324.2 Solar thermal systems.** Solar thermal systems shall be designed and installed in accordance with Chapter 23.

**R324.3 Photovoltaic systems.** Photovoltaic systems shall be designed and installed in accordance with [Section 3111 of the Building Code](#). All photovoltaic electrical installations shall comply with the *Electrical Code*.

## Habitable attic.

**R326.1 General.** *Habitable attics* shall comply with this section.

**R326.2 Minimum dimensions.** *A habitable attic shall have a floor area in accordance with Section R304 and a ceiling height in accordance with Section R305.*

**R326.3 Story above grade plane.** *A habitable attic shall be considered a story above grade plane.*

**Exception:** *A habitable attic shall not be considered to be a story above grade plane where the space meets all of the following:*

- 1. The aggregate area of the habitable attic is not greater than one-third of the floor area of the story below or, where located in dwelling units equipped throughout with an automatic fire sprinkler system in accordance with NFPA 13D, the habitable attic is not greater than one-half of the floor area of the story below.*
- 2. The occupiable space is enclosed by the roof assembly above; knee walls, if applicable, on the sides; and the floor-ceiling assembly below.*
- 3. The floor of the habitable attic does not extend beyond the exterior walls of the story below.*
- 4. Where the habitable attic is located above a third story, the dwelling unit or townhouse shall be equipped throughout with an automatic fire sprinkler system in accordance with NFPA 13D.*

## Swimming pools, spas and hot tubs.

**R329.1 General.** The design and construction of barriers for residential swimming pools which are accessory to four or fewer dwelling units shall comply with the applicable provisions of the International Swimming Pool and Spa Code.



# CHAPTER 4 FOUNDATIONS

## Footings.

**R403.1 General.** All exterior walls shall be supported on continuous solid or fully grouted masonry or concrete footings, crushed stone footings, wood foundations, or other *approved* structural systems that shall be of sufficient design to accommodate all loads according to Section R301 and to transmit the resulting loads to the soil within the limitations as determined from the character of the soil. Footings shall be supported on undisturbed natural soils or engineered fill. Concrete footing shall be designed and constructed in accordance with the provisions of Section R403 or in accordance with ACI 332.

**R403.1.1 Minimum size.** Concrete and masonry footings shall be in accordance with Table R403.1 and Figure R403.1(1) or R403.1.3, as applicable. The footing width shall be based on the load-bearing value of the soil in accordance with Table R401.4.1. Spread footings shall be not less than 6 inches (152 mm) in thickness for foundation walls supporting one floor, 7 inches (178 mm) in thickness for foundation walls supporting two floors, and 8 inches (203 mm) in thickness for foundation walls supporting three floors. Footing projections, P, shall be not less than 2 inches (51 mm) and shall not exceed the thickness of the footing. Footing thickness and projection for fireplaces shall be in accordance with Section R1001.2. The size of footings supporting piers and columns shall be based on the tributary load and allowable soil pressure in accordance with Table R401.4.1. For isolated footings, see Section R403.1.7. Footings for wood foundations shall be in accordance with the details set forth in Section R403.2, and Figures R403.1(2) and R403.1(3). Footings for precast foundations shall be in accordance with the details set forth in Section R403.4, Table R403.4, and Figures R403.4(1) and R403.4(2).

**TABLE R403.1**  
**MINIMUM WIDTH OF CONCRETE, PRECAST OR MASONRY**  
**FOOTINGS (inches)<sup>a</sup>**

	LOAD-BEARING VALUE OF SOIL (psf)			
	1,000	1,500	2,000	≥ 3,000
<b>Conventional light-frame construction</b>				
1 story	18	12	12	12
2 story	23	15	12	12
3 story	<u>35</u>	<u>23</u>	<u>17</u>	<u>12</u>
<b>4-inch brick veneer over light frame or 8-inch hollow concrete masonry</b>				
1 story	<u>18</u>	<u>12</u>	12	12
2 story	<u>32</u>	<u>21</u>	<u>16</u>	12
3 story	<u>48</u>	<u>32</u>	<u>24</u>	<u>16</u>
<b>8-inch solid concrete or masonry, or fully grouted masonry</b>				
1 story	<u>24</u>	<u>16</u>	<u>12</u>	12
2 story	<u>44</u>	<u>29</u>	<u>21</u>	14
3 story	<u>63</u>	<u>42</u>	<u>32</u>	<u>21</u>

For SI: 1 inch = 25.4 mm, 1 pound per square foot = 0.0479 kPa.

a. Where minimum footing width is 12 inches, use of a single wythe of solid or fully grouted 12-inch nominal concrete masonry units is permitted.

## Underfloor spaces.

**R408.1 Ventilation.** The under-floor space between the bottom of the floor joists and the earth under any building (except space occupied by a *basement*) shall have ventilation openings through foundation walls or exterior walls.

The ground surface of the under-floor space shall be covered by a Class I vapor retarder, or other approved material, lapped not less than 12 inches (305 mm) at the joints and extended not less than 12 inches (305 mm) up perimeter foundation walls.

The minimum net area of ventilation openings shall be not less than 1 square foot (0.0929 m<sup>2</sup>) for each 150 square feet (14 m<sup>2</sup>) of under-floor space area.

The minimum net area of ventilation openings may be reduced to 1 square foot (0.0929 m<sup>2</sup>) for each 1,500 square feet (140 m<sup>2</sup>) of under-floor space area where the ground surface is covered by the required Class I vapor retarder.

The minimum net area of ventilation openings is not permitted for naturally ventilated crawl spaces in new construction in Baker, Clackamas, Hood River, Multnomah, Polk, Washington and Yamhill counties where radon-mitigating construction is required.

The required ventilation openings shall be placed to provide cross ventilation of the space. One such ventilation opening shall be within 3 feet (914 mm) of each corner of the building.

### Exceptions:

1. Ventilation openings shall be permitted to be omitted on one side.
2. Ventilation openings are not required where a continuously operated mechanical ventilation system is installed. The system shall be designed to have the capacity to exhaust a minimum of 1.0 CFM (0.5 L/s) for each 50 square feet (4.6 L/s) of under-floor area. The ground surface shall be covered with a Class I vapor retarder, or other approved material.
3. Ventilation openings in townhouses shall be permitted to be omitted on two sides when adjoining adjacent townhouses.

**R408.2 Openings for under-floor ventilation.** Ventilation openings shall be covered for their height and width with any of the following materials provided that the least dimension of the covering shall not exceed 1/4 inch (6.4 mm):

1. Perforated sheet metal plates not less than 0.070 inch (1.8 mm) thick.
2. Expanded sheet metal plates not less than 0.047 inch (1.2 mm) thick.
3. Cast-iron grill or grating.
4. Extruded load-bearing brick vents.
5. Hardware cloth of 0.035-inch (0.89 mm) wire or heavier.
6. Corrosion-resistant wire mesh, with the least dimension being 1/8 inch (3.2 mm) thick.

The installation of operable louvers shall not be prohibited.

**R408.3 Unvented crawl space.** Ventilation openings in under-floor spaces specified in Sections R408.1 and R408.2 shall not be required where the following items are provided:

1. Exposed earth is covered with a continuous Class I vapor retarder. Joints of the vapor retarder shall overlap by 6 inches (152 mm) and shall be sealed or taped, or overlapped a minimum of 12 inches (305 mm) when joints are not sealed or taped. The edges of the vapor retarder shall extend not less than 12 inches (305 mm) up the stem wall and shall be attached and sealed to the stem wall or insulation.
2. One of the following is provided for the under-floor space:
  - 2.1. Continuously operated mechanical exhaust ventilation at a rate equal to 1 cubic foot per minute (0.47 L/s) for each 50 square feet (4.7 m<sup>2</sup>) of crawl space floor area, including an air pathway to the common area (such as a duct or transfer grille), and perimeter walls insulated in accordance with Section N1104.2.7 of this code.
  - 2.2. *Conditioned air* supply sized to deliver at a rate equal to 1 cubic foot per minute (0.47 L/s) for each 50 square feet (4.7 m<sup>2</sup>) of under-floor area, including a return air pathway to the common area (such as a duct or transfer grille), and perimeter walls insulated in accordance with Section N1104.2.7 of this code.
  - 2.3. Dehumidification sized to provide 70 pints (33 liters) of moisture removal per day for every 1,000 square feet (93 m<sup>2</sup>) of *crawl space* floor area.

**Exception:** Unvented crawl spaces are not allowed in new construction in Baker, Clackamas, Hood River, Multnomah, Polk, Washington and Yamhill counties where radon-mitigating construction is required, unless an approved mechanical ventilation system is provided in accordance with the exception in Section AF103.5 and the requirements of R408.3 are met.

## Reinforcement for foundation walls.

TABLE R404.1.2(1)  
MINIMUM HORIZONTAL REINFORCEMENT FOR CONCRETE FOUNDATION WALLS<sup>a, b</sup>

MAXIMUM UNSUPPORTED HEIGHT OF FOUNDATION WALL (feet)	LOCATION OF HORIZONTAL REINFORCEMENT
≤ 5	One No. 4 bar within 12 inches of the top of the wall
> 5 to ≤ 8	One No. 4 bar within 12 inches of the top of the wall and one No. 4 bar near mid-height of the wall
> 8	One No. 4 bar within 12 inches of the top of the wall and one No. 4 bar near third points in the wall

For SI: 1 inch = 25.4 mm, 1 foot = 304.8 mm, 1 pound per square inch = 6.895 kPa.

- a. Horizontal reinforcement requirements are for reinforcing bars with a minimum yield strength of 40,000 psi and concrete with a minimum concrete compressive strength of 2,500 psi.
- b. See Section R404.1.3.2 for minimum reinforcement required for foundation walls supporting above-grade concrete walls.

# CHAPTER 5 FLOORS

## Exterior decks.

**R507.1 Decks.** Wood-framed decks shall be in accordance with this section. For decks using materials and conditions not prescribed in this section, refer to Section R301.

**R507.2 Materials.** Materials used for the construction of decks shall comply with this section.

**R507.2.1 Wood materials.** Wood materials shall be No. 2 grade or better lumber, preservative-treated in accordance with Section R317, or *approved*, naturally durable lumber. Where design in accordance with Section R301 is provided, wood structural members shall be designed using the wet service factor defined in AWC NDS. Cuts, notches and drilled holes of preservative-treated wood members shall be treated in accordance with Section R317.1.1. All preservative-treated wood products in contact with the ground shall be labeled for such usage.

**R507.2.1.1 Engineered wood products.** Engineered wood products shall be in accordance with Section R502.

**R507.2.2 Plastic composite deck boards, stair treads, guards, or handrails.** Plastic composite exterior deck boards, stair treads, guards and handrails shall comply with the requirements of ASTM D7032 and this section.

**R507.2.2.1 Labeling.** Plastic composite deck boards and stair treads, or their packaging, shall bear a label that indicates compliance with ASTM D7032 and includes the allowable load and maximum allowable span determined in accordance with ASTM D7032. Plastic or composite handrails and guards, or their packaging, shall bear a label that indicates compliance with ASTM D7032 and includes the maximum allowable span determined in accordance with ASTM D7032.

**R507.2.2.2 Flame spread index.** Plastic composite deck boards, stair treads, guards, and handrails shall exhibit a flame spread index not exceeding 200 when tested in accordance with ASTM E84 or UL 723 with the test specimen remaining in place during the test.

**Exception:** Plastic composites determined to be noncombustible.

**R507.2.2.3 Decay resistance.** Plastic composite deck boards, stair treads, guards and handrails containing wood, cellulosic or other biodegradable materials shall be decay resistant in accordance with ASTM D7032.

**R507.2.2.4 Installation of plastic composites.** Plastic composite deck boards, stair treads, guards and handrails shall be installed in accordance with this code and the manufacturer's instructions.

**R507.2.3 Fasteners and connectors.** Metal fasteners and connectors used for all decks shall be in accordance with Section R317.3 and Table R507.2.3.

**R507.2.4 Flashing.** Flashing shall be corrosion-resistant metal of nominal thickness not less than 0.019 inch (0.48 mm) or *approved* nonmetallic material that is compatible with the substrate of the structure and the decking materials.

**R507.2.5 Alternate materials.** Alternative materials, including glass and metals, shall be permitted.

**R507.3 Footings.** Decks shall be supported on concrete footings or other approved structural systems designed to accommodate all loads in accordance with Section R301. Deck footings shall be sized to carry the imposed loads from the deck structure to the ground as shown in Figure R507.3. The footing depth shall be in accordance with Section R403.1.4.

**Exception:** Free-standing decks consisting of joists directly supported on grade over their entire length.

**R507.3.1 Minimum size.** The minimum size of concrete footings shall be in accordance with Table R507.3.1, based on the tributary area and allowable soil-bearing pressure in accordance with Table R401.4.1.

**R507.3.2 Minimum depth.** Deck footings shall extend below the frost line specified in Table R301.2(1) in accordance with Section R403.1.4.1.

**Exception:** Free-standing decks need not be provided with footings that extend below the frost line.

**R507.4 Deck posts.** For single-level wood-framed decks with beams sized in accordance with Table R507.5, deck post size shall be in accordance with Table R507.4.

**TABLE R507.4  
DECK POST HEIGHT<sup>a, b</sup>**

DECK POST SIZE	MAXIMUM HEIGHT <sup>a, b</sup> (feet-inches)
4 × 4	6-9 <sup>c</sup>
4 × 6	8
6 × 6	14
8 × 8	14

For SI: 1 inch = 25.4 mm, 1 foot = 304.8 mm, 1 pound per square foot = 0.0479 kPa.

a. Measured to the underside of the beam.

b. Based on 40 psf live load.

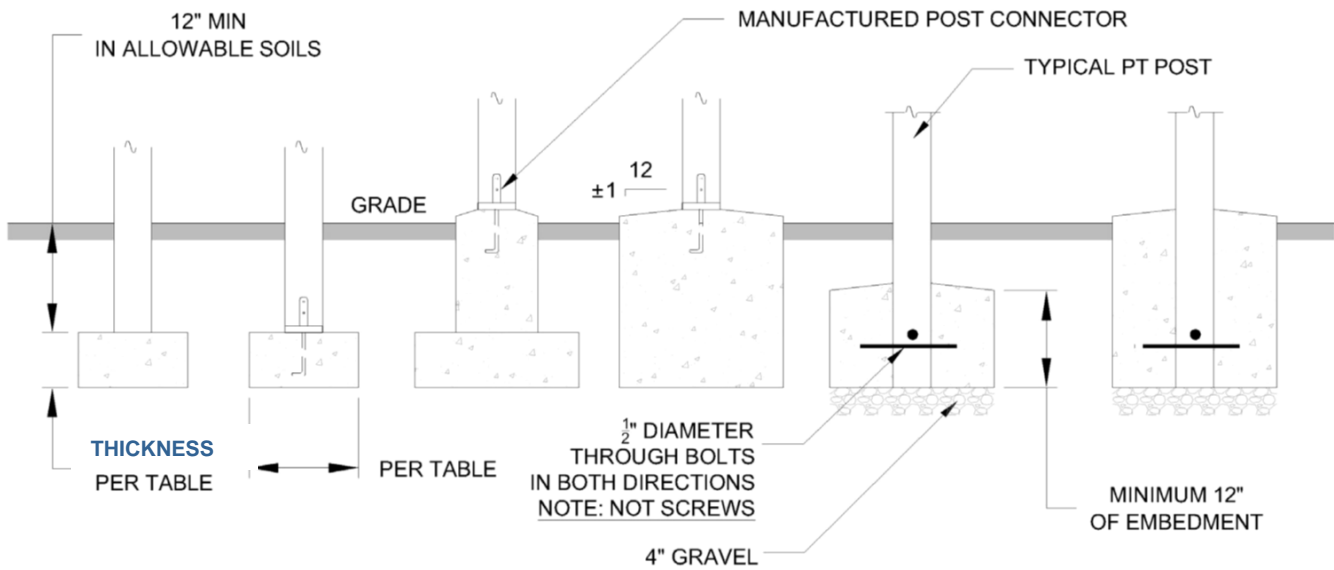
c. The maximum permitted height is 8 feet for one-ply and two-ply beams. The maximum permitted height for three-ply beams on post cap is 6 feet 9 inches.

**TABLE R507.2.3  
FASTENER AND CONNECTOR SPECIFICATIONS FOR DECKS<sup>a, b</sup>**

ITEM	MATERIAL	MINIMUM FINISH/COATING	ALTERNATE FINISH/COATING <sup>e</sup>
Nails and timber rivets	In accordance with ASTM F1667	Hot-dipped galvanized per ASTM A153	Stainless steel, silicon bronze or copper
Bolts <sup>c</sup> Lag screws <sup>d</sup> (including nuts and washers)	In accordance with ASTM A307 (bolts), ASTM A563 (nuts), ASTM F844 (washers)	Hot-dipped galvanized per ASTM A153, Class C (Class D for 3/8-inch diameter and less) or mechanically galvanized per ASTM B695, Class 55 or 410 stainless steel	Stainless steel, silicon bronze or copper
Metal connectors	Per manufacturer's specification	ASTM A653 type G185 zinc coated galvanized steel or post hot-dipped galvanized per ASTM A123 providing a minimum average coating weight of 2.0 oz./ft <sup>2</sup> (total both sides)	Stainless steel

For SI: 1 inch = 25.4 mm, 1 foot = 304.8 mm.

- a. Equivalent materials, coatings and finishes shall be permitted.
- b. Fasteners and connectors exposed to salt water or located within 300 feet of a salt water shoreline shall be stainless steel.
- c. Holes for bolts shall be drilled a minimum 1/32 inch and a maximum 1/16 inch larger than the bolt.
- d. Lag screws 1/2 inch and larger shall be predrilled to avoid wood splitting per the National Design Specification (NDS) for Wood Construction.
- e. Stainless-steel-driven fasteners shall be in accordance with ASTM F1667.



NOTE:  
POSTS MUST BE CENTERED ON OR IN FOOTING

**FIGURE R507.3  
DECK POSTS TO DECK FOOTING CONNECTION**

**TABLE R507.3.1  
MINIMUM FOOTING SIZE FOR DECKS**

LIVE OR GROUND SNOW LOAD <sup>b</sup> (psf)	TRIBUTARY AREA <sup>e</sup> (sq. ft.)	LOAD BEARING VALUE OF SOILS <sup>a, c, d</sup> (psf)											
		1500			2000			2500			≥ 3000		
		Side of a square footing (inches)	Diameter of a round footing (inches)	Thickness (inches)	Side of a square footing (inches)	Diameter of a round footing (inches)	Thickness (inches)	Side of a square footing (inches)	Diameter of a round footing (inches)	Thickness (inches)	Side of a square footing (inches)	Diameter of a round footing (inches)	Thickness (inches)
40	20	12	14	6	12	14	6	12	14	6	12	14	6
	40	14	16	6	12	14	6	12	14	6	12	14	6
	60	17	19	6	15	17	6	13	15	6	12	14	6
	80	20	22	7	17	19	6	15	17	6	14	16	6
	100	22	25	8	19	21	6	17	19	6	15	17	6
	120	24	27	9	21	23	7	19	21	6	17	19	6
	140	26	29	10	22	25	8	20	23	7	18	21	6
	160	28	31	11	24	27	9	21	24	8	20	22	7
50	20	12	14	6	12	14	6	12	14	6	12	14	6
	40	15	17	6	13	15	6	12	14	6	12	14	6
	60	19	21	6	16	18	6	14	16	6	13	15	6
	80	21	24	8	19	21	6	17	19	6	15	17	6
	100	24	27	9	21	23	7	19	21	6	17	19	6
	120	26	30	10	23	26	8	20	23	7	19	21	6
	140	28	32	11	25	28	9	22	25	8	20	23	7
	160	30	34	12	26	30	10	24	27	9	21	24	8
60	20	12	14	6	12	14	6	12	14	6	12	14	6
	40	16	19	6	14	16	6	13	14	6	12	14	6
	60	20	23	7	17	20	6	16	18	6	14	16	6
	80	23	26	9	20	23	7	18	20	6	16	19	6
	100	26	29	10	22	25	8	20	23	7	18	21	6
	120	28	32	11	25	28	9	22	25	8	20	23	7
	140	31	35	12	27	30	10	24	27	9	22	24	8
	160	33	37	13	28	32	11	25	29	10	23	26	9
70	20	12	14	6	12	14	6	12	14	6	12	14	6
	40	18	20	6	15	17	6	14	15	6	12	14	6
	60	21	24	8	19	21	6	17	19	6	15	17	6
	80	25	28	9	21	24	8	19	22	7	18	20	6
	100	28	31	11	24	27	9	21	24	8	20	22	7
	120	30	34	12	26	30	10	24	27	9	21	24	8
	140	33	37	13	28	32	11	25	29	10	23	26	9
	160	35	40	15	30	34	12	27	31	11	25	28	9

For SI: 1 inch = 25.4 mm, 1 square foot = 0.0929 m<sup>2</sup>, 1 pound per square foot = 0.0479 kPa.

- Interpolation permitted, extrapolation not permitted.
- Based on highest load case: Dead + Live or Dead + Snow.
- Assumes minimum square footing to be 12 inches x 12 inches x 6 inches for 6 x 6 post.
- If the support is a brick or CMU pier, the footing shall have a minimum 2-inch projection on all sides.
- Area, in square feet, of deck surface supported by post and footings.



**R507.4.1 Deck post to deck footing connection.** Where posts bear on concrete footings in accordance with Section R403 and Figure R507.4.1, lateral restraint shall be provided by manufactured connectors or a minimum post embedment of 12 inches (305 mm) in surrounding soils or concrete piers. Other footing systems shall be permitted.

**Exception:** Where expansive, compressible, shifting or other questionable soils are present, surrounding soils shall not be relied on for lateral support.

**R507.5 Deck Beams.** Maximum allowable spans for wood deck beams, as shown in Figure R507.5, shall be in accordance with Table R507.5. Beam plies shall be fastened with two rows of 10d (3-inch × 0.128-inch) nails minimum at 16 inches (406 mm) on center along each edge. Beams shall be permitted to cantilever at each end up to one-fourth of the allowable beam span. Deck beams of other materials shall be permitted where designed in accordance with accepted engineering practices.

**R507.5.1 Deck beam bearing.** The ends of beams shall have not less than 1½ inches (38 mm) of bearing on wood or metal and not less than 3 inches (76 mm) of bearing on concrete or masonry for the entire width of the beam. Where multiple-span beams bear on intermediate posts, each ply must have full bearing on the post in accordance with Figures R507.5.1(1) and R507.5.1(2).

**R507.5.2 Deck beam connection to supports.** Deck beams shall be attached to supports in a manner capable of transferring vertical loads and resisting horizontal displacement. Deck beam connections to wood posts shall be in accordance with Figures R507.5.1(1) and R507.5.1(2). Manufactured post-to-beam connectors shall be sized for the post and beam sizes. Bolts shall have washers under the head and nut.

**R507.6 Deck joists.** Maximum allowable spans for wood deck joists, as shown in Figure R507.6, shall be in accordance with Table R507.6. The maximum joist spacing shall be limited by the decking materials in accordance with Table R507.7. The maximum joist cantilever shall be limited to one-fourth of the joist span or the maximum cantilever length specified in Table R507.6, whichever is less.

**R507.6.1 Deck joist bearing.** The ends of joists shall have not less than 1½ inches (38 mm) of bearing on wood or metal and not less than 3 inches (76 mm) of bearing on concrete or masonry over its entire width. Joists bearing on top of a multiple-ply beam or ledger shall be fastened in accordance with Table R602.3(1). Joists bearing on top of a single-ply beam or ledger shall be attached by a mechanical connector. Joist framing into the side of a beam or ledger board shall be supported by approved joist hangers.

**R507.6.2 Deck joist lateral restraint.** Joist ends and bearing locations shall be provided with lateral resistance to prevent rotation. Where lateral restraint is provided by joist hangers or blocking between joists, their depth shall equal not less than 60 percent of the joist depth. Where lateral restraint is provided by rim joists, they shall be secured to the end of each joist with not fewer than three 10d (3-inch by 0.128-inch) (76 mm by 3.3 mm) nails or three No. 10 x 3-inch (76 mm) long wood screws.

**R507.7 Decking.** Maximum allowable spacing for joists supporting decking shall be in accordance with Table R507.7. Wood decking shall be attached to each supporting member with not less than two 8d threaded nails or two No. 8 wood screws. Other approved decking or fastener systems shall be installed in accordance with the manufacturer's installation requirements.

**R507.8 Vertical and lateral supports.** Where supported by attachment to an exterior wall, decks shall be positively anchored to the primary structure and designed for both vertical and lateral loads. Such attachment shall not be accomplished by the use of toenails or nails subject to withdrawal. For decks with cantilevered framing members, connection to exterior walls or other framing members shall be designed and constructed to resist uplift resulting from the full live load specified in Table R301.5 acting on the cantilevered portion of the deck. Where positive connection to the primary building structure cannot be verified during inspection, decks shall be self-supporting.

**R507.9 Vertical and lateral supports at band joist.** Vertical and lateral supports for decks shall comply with this section.

**R507.9.1 Vertical supports.** Vertical loads shall be transferred to band joists with ledgers in accordance with this section.

**R507.9.1.1 Ledger details.** Deck ledgers shall be a minimum 2-inch by 8-inch (51 mm by 203 mm) nominal, pressure-preservative-treated Southern pine, incised pressure-preservative-treated hem-fir, or approved, naturally durable, No. 2 grade or better lumber. Deck ledgers shall not support concentrated loads from beams or girders. Deck ledgers shall not be supported on stone or masonry veneer.

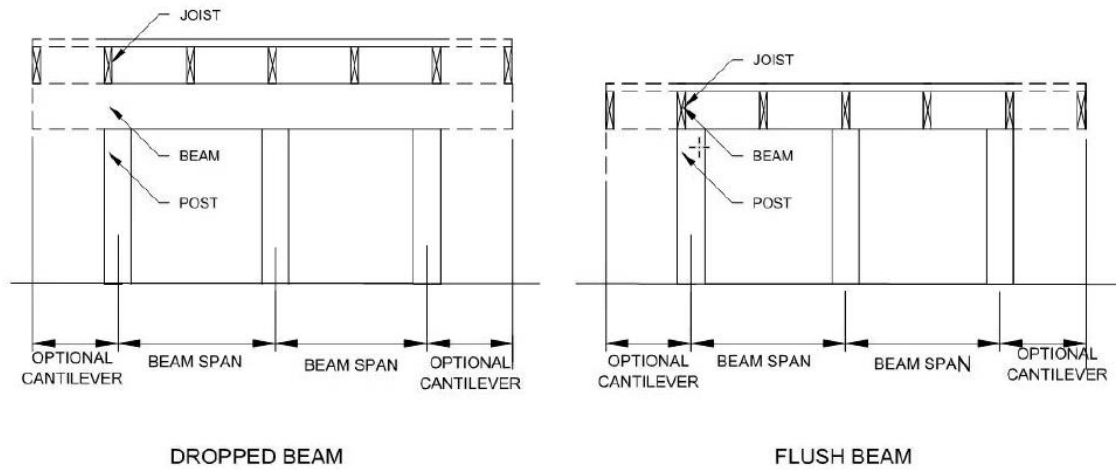
**R507.9.1.2 Band joist details.** Band joists supporting a ledger shall be a minimum 2-inch-nominal (51 mm), solid-sawn, spruce-pine-fir or better lumber or a minimum 1-inch by 9½-inch (25 mm × 241 mm) dimensional, Douglas fir or better, laminated veneer lumber. Band joists shall bear fully on the primary structure capable of supporting all required loads.

**R507.9.1.3 Ledger to band joist details.** Fasteners used in deck ledger connections in accordance with Table R507.9.1.3(1) shall be hot-dipped galvanized or stainless steel and shall be installed in accordance with Table R507.9.1.3(2) and Figures R507.9.1.3(1) and R507.9.1.3(2).

**R507.9.1.4 Alternate ledger details.** Alternate framing configurations supporting a ledger constructed to meet the load requirements of Section R301.5 shall be permitted.

**R507.9.2 Lateral connection.** Lateral loads shall be transferred to the ground or to a structure capable of transmitting them to the ground. Where the lateral load connection is provided in accordance with Figure R507.9.2(1), hold-down tension devices shall be installed in not less than two locations per deck, within 24 inches (610 mm) of each end of the deck. Each device shall have an allowable stress design capacity of not less than 1,500 pounds (6672 N). Where the lateral load connections are provided in accordance with Figure R507.9.2(2), the hold-down tension devices shall be installed in not less than four locations per deck, and each device shall have an allowable stress design capacity of not less than 750 pounds (3336N).





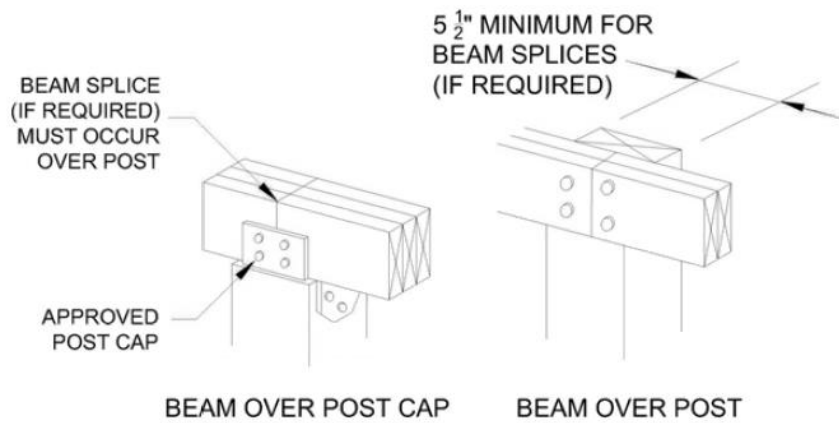
**FIGURE R507.5  
TYPICAL DECK JOIST SPANS**

**TABLE R507.5  
DECK BEAM SPAN LENGTHS<sup>a, b, g</sup> (feet - inches)**

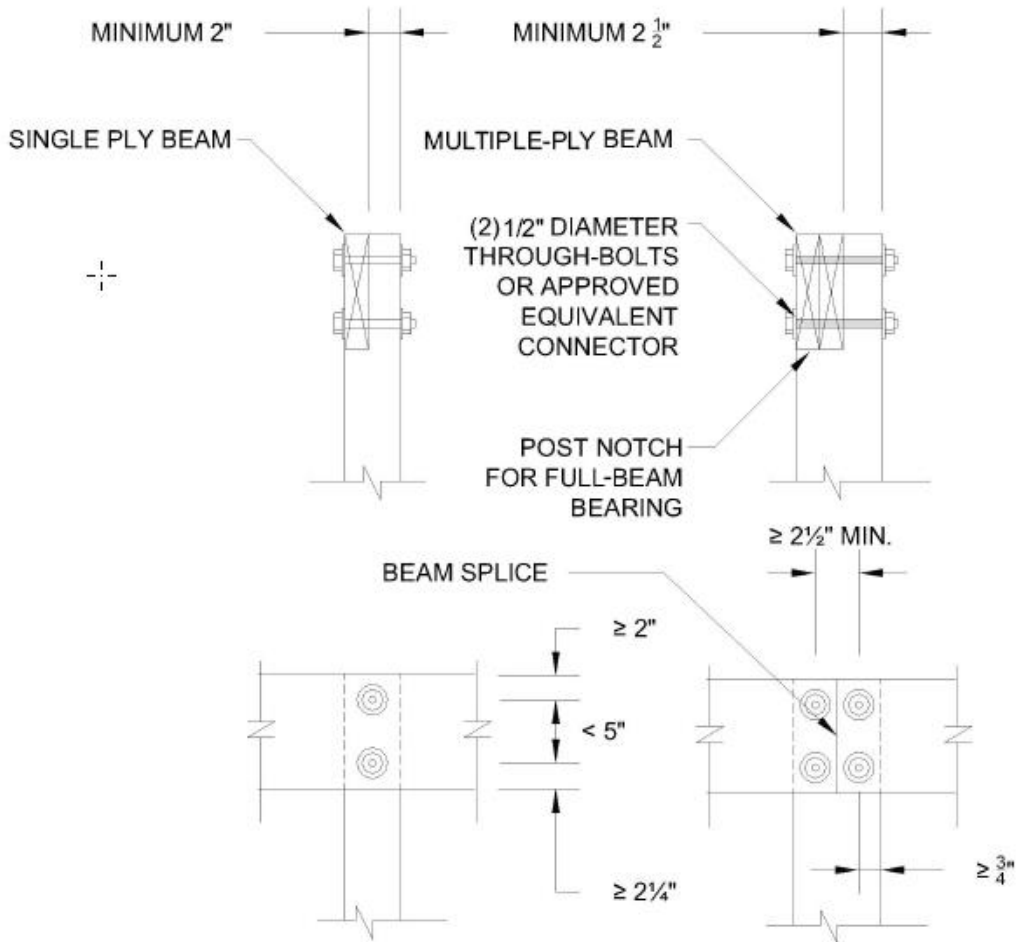
SPECIES <sup>c</sup>	SIZE <sup>d</sup>	DECK JOIST SPAN LESS THAN OR EQUAL TO: (feet)						
		6	8	10	12	14	16	18
Southern pine	1 – 2 × 6	4-11	4-0	3-7	3-3	3-0	2-10	2-8
	1 – 2 × 8	5-11	5-1	4-7	4-2	2-10	3-7	3-5
	1 – 2 × 10	7-0	6-0	5-5	4-11	4-7	4-3	4-0
	1 – 2 × 12	8-3	7-1	6-4	5-10	5-5	5-0	4-9
	2 – 2 × 6	6-11	5-11	5-4	4-10	4-6	4-3	4-0
	2 – 2 × 8	8-9	7-7	6-9	6-2	5-9	5-4	5-0
	2 – 2 × 10	10-4	9-0	8-0	7-4	6-9	6-4	6-0
	2 – 2 × 12	12-2	10-7	9-5	8-7	8-0	7-6	7-0
	3 – 2 × 6	8-2	7-5	6-8	6-1	5-8	5-3	5-0
	3 – 2 × 8	10-10	9-6	8-6	7-9	7-2	6-8	6-4
	3 – 2 × 10	13-0	11-3	10-0	9-2	8-6	7-11	7-6
3 – 2 × 12	15-3	13-3	11-10	10-9	10-0	9-4	8-10	
Douglas fir-larch <sup>e</sup> , hem-fir <sup>e</sup> , spruce-pine-fir <sup>e</sup> , redwood, western cedars, ponderosa pine <sup>f</sup> , red pine <sup>f</sup>	3 × 6 or 2 – 2 × 6	5-5	4-8	4-2	3-10	3-6	3-1	2-9
	3 × 8 or 2 – 2 × 8	6-10	5-11	5-4	4-10	4-6	4-1	3-8
	3 × 10 or 2 – 2 × 10	8-4	7-3	6-6	5-11	5-6	5-1	4-8
	3 × 12 or 2 – 2 × 12	9-8	8-5	7-6	6-10	6-4	5-11	5-7
	4 × 6	6-5	5-6	4-11	4-6	4-2	3-11	3-8
	4 × 8	8-5	7-3	6-6	5-11	5-6	5-2	4-10
	4 × 10	9-11	8-7	7-8	7-0	6-6	6-1	5-8
	4 × 12	11-5	9-11	8-10	8-1	7-6	7-0	6-7
	3 – 2 × 6	7-4	6-8	6-0	5-6	5-1	4-9	4-6
	3 – 2 × 8	9-8	8-6	7-7	6-11	6-5	6-0	5-8
	3 – 2 × 10	12-0	10-5	9-4	8-6	7-10	7-4	6-11
	3 – 2 × 12	13-11	12-1	10-9	9-10	9-1	8-6	8-1

For SI: 1 inch = 25.4 mm, 1 foot = 304.8 mm, 1 pound per square foot = 0.0479 kPa, 1 pound = 0.454 kg.

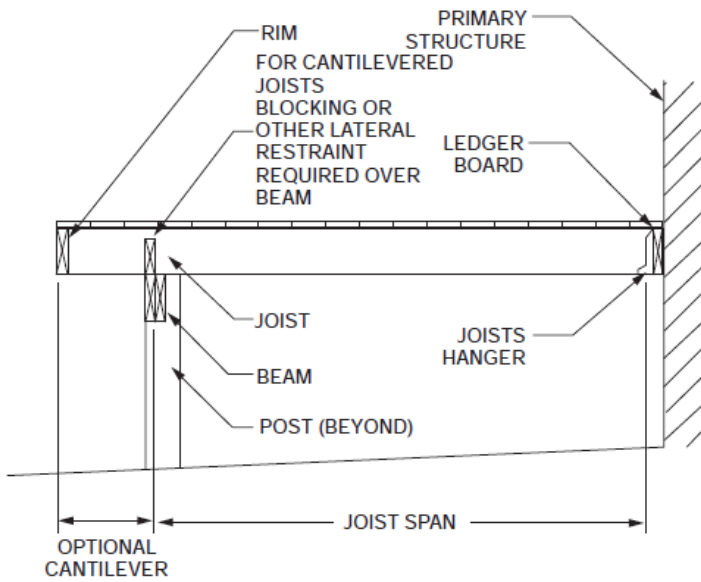
- Ground snow load, live load = 40 psf, dead load = 10 psf,  $L/\Delta = 360$  at main span,  $L/\Delta = 180$  at cantilever with a 220-pound point load applied at the end.
- Beams supporting deck joists from one side only.
- No. 2 grade, wet service factor.
- Beam depth shall be greater than or equal to depth of joists with a flush beam condition.
- Includes incising factor.
- Northern species. Incising factor not included.
- Beam cantilevers are limited to the adjacent beam's span divided by 4.



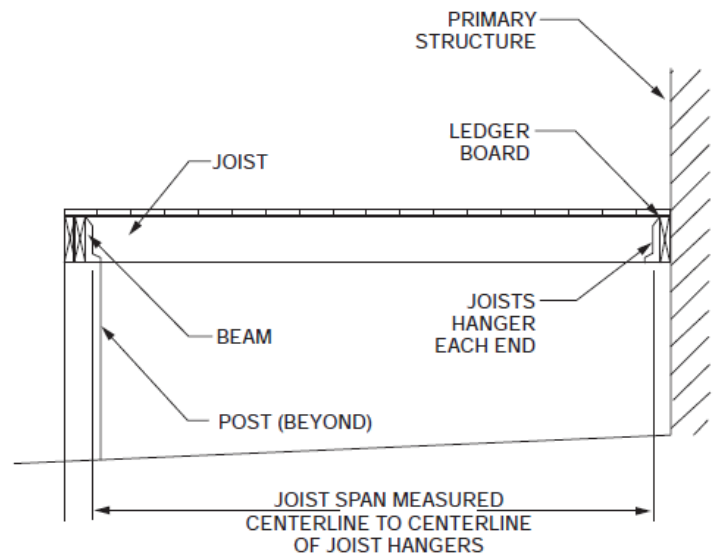
**FIGURE R507.5.1(1)  
DECK BEAM TO DECK POST**



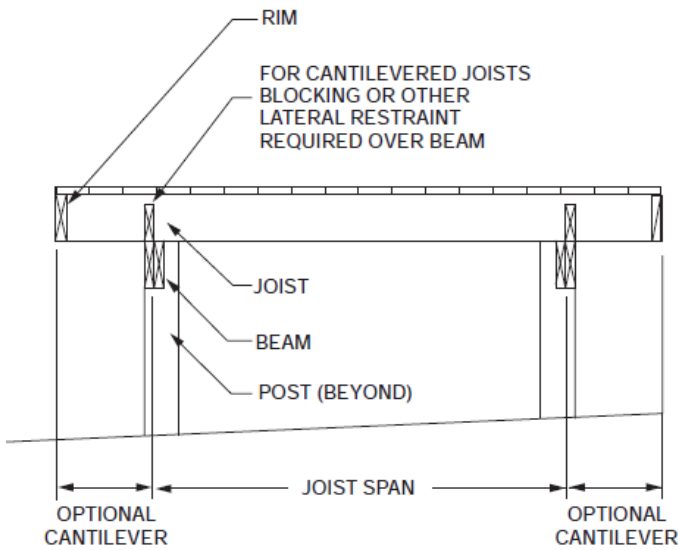
**FIGURE R507.5.1(2)  
NOTCHED POST-TO-BEAM CONNECTION**



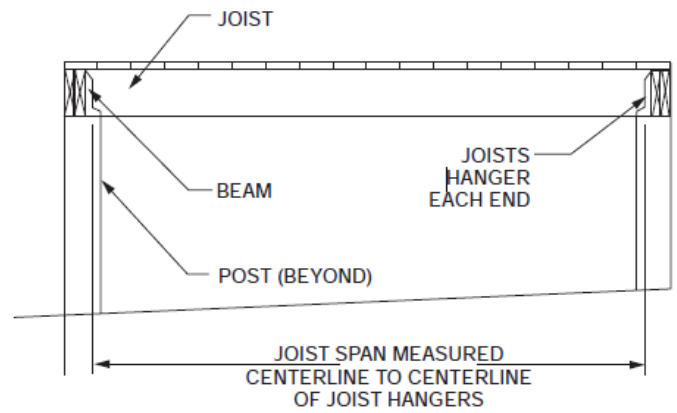
CANTILEVERED JOISTS WITH DROPPED BEAM



JOISTS WITH FLUSH BEAM



JOISTS ON FREE-STANDING DECK WITH DROPPED BEAM



JOISTS ON FREE-STANDING DECK WITH FLUSH BEAM

FIGURE R507.6  
TYPICAL DECK JOIST SPANS

**TABLE R507.6  
ECK JOIST SPANS FOR COMMON LUMBER SPECIES (ft. - in.)**

SPECIES <sup>a</sup>	SIZE	ALLOWABLE JOIST SPAN <sup>b</sup>			MAXIMUM CANTILEVER <sup>c, f</sup>		
		SPACING OF DECK JOISTS (inches)			SPACING OF DECK JOISTS WITH CANTILEVERS <sup>c</sup> (inches)		
		12	16	24	12	16	24
Southern pine	2 × 6	9-11	9-0	7-7	1-3	1-4	1-6
	2 × 8	13-1	11-10	9-8	2-1	2-3	2-5
	2 × 10	16-2	14-0	11-5	3-4	3-6	2-10
	2 × 12	18-0	16-6	13-6	4-6	4-2	3-4
Douglas fir-larch <sup>d</sup> , hem-fir <sup>d</sup> , spruce-pine-fir <sup>d</sup> ,	2 × 6	9-6	8-8	7-2	1-2	1-3	1-5
	2 × 8	12-6	11-1	9-1	1-11	2-1	2-3
	2 × 10	15-8	13-7	11-1	3-1	3-5	2-9
	2 × 12	18-0	15-9	12-10	4-6	3-11	3-3
Redwood, western cedars, ponderosa pine <sup>e</sup> , red pine <sup>e</sup>	2 × 6	8-10	8-0	7-0	1-0	1-1	1-2
	2 × 8	11-8	10-7	8-8	1-8	1-10	2-0
	2 × 10	14-11	13-0	10-7	2-8	2-10	2-8
	2 × 12	17-5	15-1	12-4	3-10	3-9	3-1

For SI: 1 inch = 25.4 mm, 1 foot = 304.8 mm, 1 pound per square foot = 0.0479 kPa, 1 pound = 0.454 kg.

- No. 2 grade with wet service factor.
- Ground snow load, live load = 40 psf, dead load = 10 psf, L/Δ = 360.
- Ground snow load, live load = 40 psf, dead load = 10 psf, L/Δ = 360 at main span, L/Δ = 180 at cantilever with a 220-pound point load applied to end.
- Includes incising factor.
- Northern species with no incising factor.
- Cantilevered spans not exceeding the nominal depth of the joist are permitted.

**TABLE R507.7  
MAXIMUM JOIST SPACING FOR DECKING**

DECKING MATERIAL TYPE AND NOMINAL SIZE	MAXIMUM ON-CENTER JOIST SPACING	
	Decking perpendicular to joist	Decking diagonal to joist <sup>a</sup>
1 1/4-inch-thick wood	16 inches	12 inches
2-inch-thick wood	24 inches	16 inches
Plastic composite	In accordance with Section R507.2	In accordance with Section R507.2

For SI: 1 inch = 25.4 mm, 1 foot = 304.8 mm, 1 degree = 0.01745 rad.

- Maximum angle of 45 degrees from perpendicular for wood deck boards.

**TABLE R507.9.1.3(1)  
DECK LEDGER CONNECTION TO BAND JOIST<sup>a, b</sup>  
(Deck live load = 40 psf, deck dead load = 10 psf, snow load ≤ 40 psf)**

CONNECTION DETAILS	JOIST SPAN						
	6' and less	6'1" to 8'	8'1" to 10'	10'1" to 12'	12'1" to 14'	14'1" to 16'	16'1" to 18'
	On-center spacing of fasteners						
1/2-inch diameter lag screw with 1/2-inch maximum sheathing <sup>c, d</sup>	30	23	18	15	13	11	10
1/2-inch diameter bolt with 1/2-inch maximum sheathing <sup>d</sup>	36	36	34	29	24	21	19
1/2-inch diameter bolt with 1-inch maximum sheathing <sup>e</sup>	36	36	29	24	21	18	16

For SI: 1 inch = 25.4 mm, 1 foot = 304.8 mm, 1 pound per square foot = 0.0479 kPa.

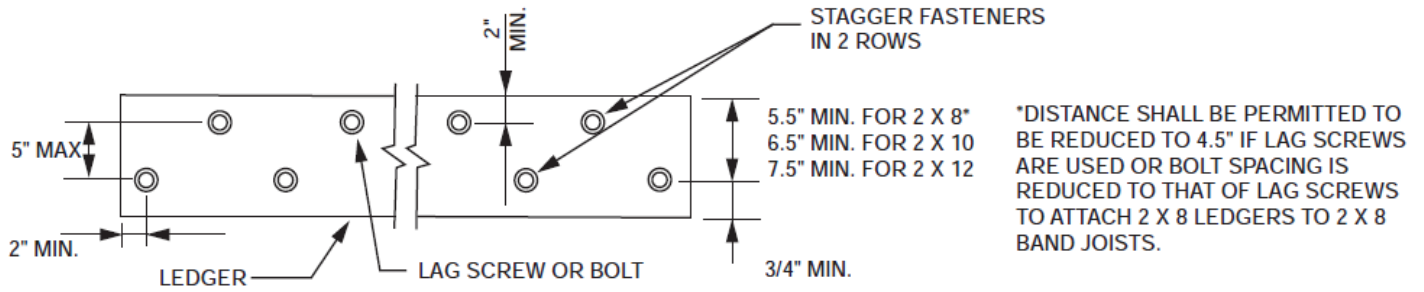
- Ledgers shall be flashed in accordance with Section R703.4 to prevent water from contacting the house band joist.
- Snow load shall not be assumed to act concurrently with live load.
- The tip of the lag screw shall fully extend beyond the inside face of the band joist.
- Sheathing shall be wood structural panel or solid sawn lumber.
- Sheathing shall be permitted to be wood structural panel, gypsum board, fiberboard, lumber or foam sheathing. Up to 1/2-inch thickness of stacked washers shall be permitted to substitute for up to 1/2 inch of allowable sheathing thickness where combined with wood structural panel or lumbersheathing.

**TABLE R507.9.1.3(2)  
PLACEMENT OF LAG SCREWS AND BOLTS IN DECK LEDGERS AND BAND JOISTS**

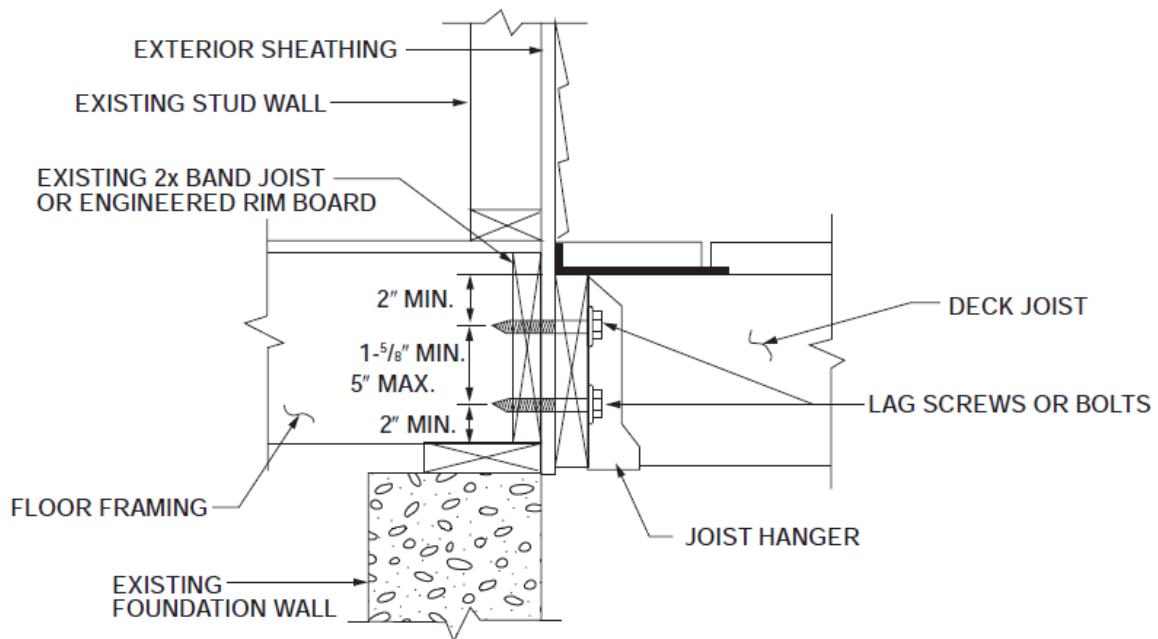
MINIMUM END AND EDGE DISTANCES AND SPACING BETWEEN ROWS				
	TOP EDGE	BOTTOM EDGE	ENDS	ROW SPACING
Ledger <sup>a</sup>	2 inches <sup>d</sup>	<sup>3</sup> / <sub>4</sub> inch	2 inches <sup>b</sup>	1 <sup>5</sup> / <sub>8</sub> inches <sup>b</sup>
Band Joist <sup>c</sup>	<sup>3</sup> / <sub>4</sub> inch	2 inches	2 inches <sup>b</sup>	1 <sup>5</sup> / <sub>8</sub> inches <sup>b</sup>

For SI: 1 inch = 25.4 mm.

- Lag screws or bolts shall be staggered from the top to the bottom along the horizontal run of the deck ledger in accordance with Figure R507.9.1.3(1).
- Maximum 5 inches.
- For engineered rim joists, the manufacturer's recommendations shall govern.
- The minimum distance from bottom row of lag screws or bolts to the top edge of the ledger shall be in accordance with Figure R507.9.1.3(1).

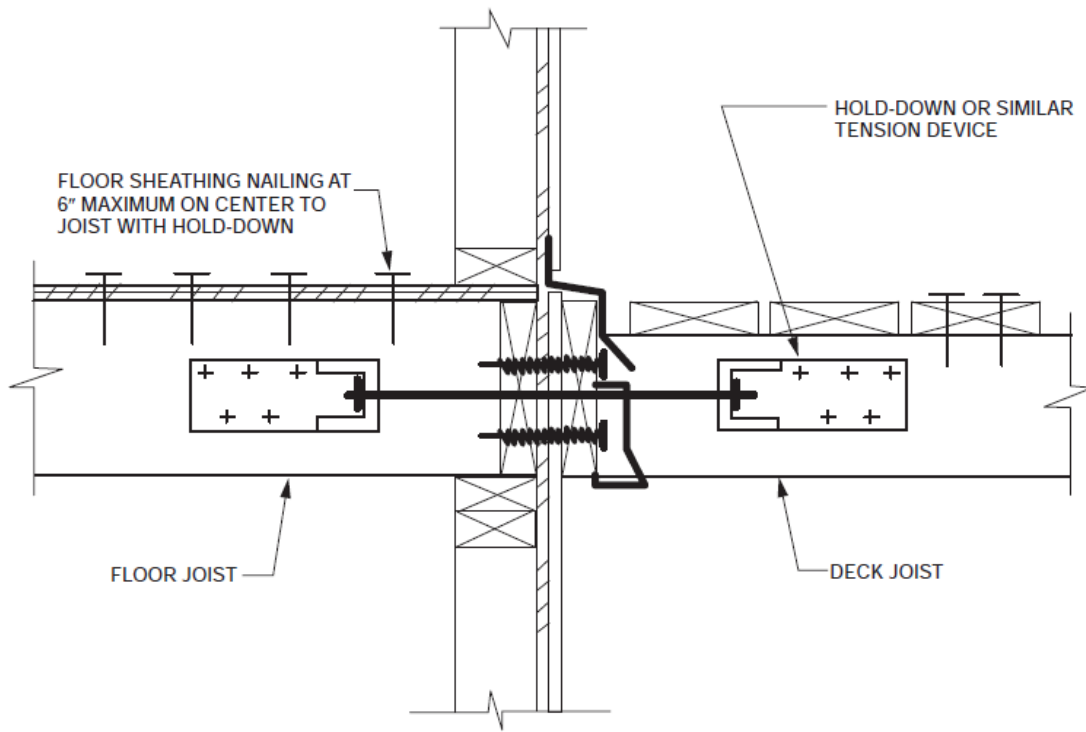


**FIGURE R507.9.1.3(1)**  
**PLACEMENT OF LAG SCREWS AND BOLTS IN LEDGERS**

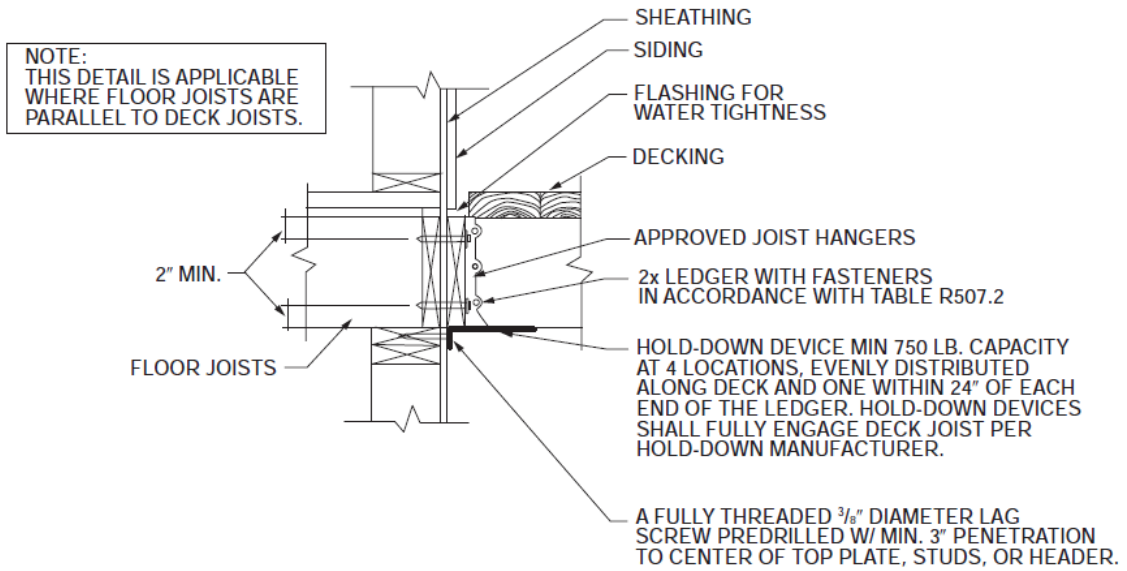


**FIGURE R507.9.1.3(2)**  
**PLACEMENT OF LAG SCREWS AND BOLTS IN BAND JOISTS**





**FIGURE R507.9.2(1)**  
**DECK ATTACHMENT FOR LATERAL LOADS**



**FIGURE R507.9.2(2)**  
**DECK ATTACHMENT FOR LATERAL LOADS**

## CHAPTER 6 WALL CONSTRUCTION

### Cripple walls.

**R602.9 Cripple walls.** Foundation cripple walls shall be framed of studs not smaller than the studding above. Where exceeding 4 feet (1219 mm) in height, such walls shall be framed of studs having the size required for an additional *story*.

Exterior cripple walls with a stud height less than 14 inches (356 mm) shall be continuously sheathed on one side with wood structural panels fastened to both the top and bottom plates in accordance with Table R602.3(1), or the cripple walls shall be constructed of solid blocking.

Cripple walls shall be supported on continuous foundations.

### Wall bracing offsets.

**R602.10.1.2 Offsets along a braced wall line.** Exterior walls parallel to a *braced wall line* shall be offset not more than 4 feet (1219 mm) from the designated *braced wall line* location as shown in Figure R602.10.1.1. Interior walls used as bracing shall be offset not more than 4 feet (1219 mm) from a *braced wall line* through the interior of the building as shown in Figure R602.10.1.1. Where all of the braced wall panels along a braced wall line occur within a single line, the braced wall line shall be located at the aligned braced wall panels, and an offset of the braced wall line is not permitted.

### Mixing wall bracing methods.

**R602.10.4.1 Mixing methods.** Mixing of bracing methods shall be permitted as follows:

1. Mixing intermittent bracing and continuous sheathing methods from story to story shall be permitted.
2. Mixing intermittent bracing methods from *braced wall line* to *braced wall line* within a story shall be permitted.
3. Mixing intermittent bracing and continuous sheathing methods from braced wall line to braced wall line within a story shall be permitted in regions within Seismic Design Categories A, B and C where the basic design wind speed is less than or equal to 130 mph (58m/s).
4. Mixing intermittent bracing methods along a *braced wall line* shall be permitted in Seismic Design Categories A and B, and detached dwellings in Seismic Design Category C, provided that the length of required bracing in accordance with Table R602.10.3(1) or R602.10.3(3) is the highest value of all intermittent bracing methods used.

5. Mixing of continuous sheathing methods CSWSP, CS-G and CS-PF along a *braced wall line* shall be permitted. Intermittent methods ABW, PFH and PFG shall be permitted to be used along a *braced wall line* with continuous sheathed methods, provided that the length of required bracing for that braced wall line is determined in accordance with Table R602.10.3(1) or R602.10.3(3) using the highest value of the bracing methods used.
6. In Seismic Design Categories A and B, and for detached one- and two-family dwellings in Seismic Design Category C, mixing of intermittent bracing methods along the interior portion of a *braced wall line* with continuous sheathing methods CS-WSP, CS-G and CS-PF along the exterior portion of the same braced wall line shall be permitted. The length of required bracing shall be the highest value of all intermittent bracing methods used in accordance with Table R602.10.3(1) or R602.10.3(3) as adjusted by Tables R602.10.3(2) and R602.10.3(4), respectively. The requirements of Section R602.10.7 shall apply to each end of the continuously sheathed portion of the braced wall line.

### Braced wall panel joints.

**R602.10.4.4 Panel joints.** Vertical joints of panel sheathing shall occur over and be fastened to common studs. Horizontal joints of panel sheathing in *braced wall panels* shall occur over and be fastened to common blocking of a thickness of 1 1/2 inches (38 mm) or greater.

#### Exceptions:

1. For methods WSP and CS-WSP, blocking of horizontal joints is permitted to be omitted when adjustment factor No. 8 of Table R602.10.3(2) or No. 9 of Table R602.10.3(4) is applied.
2. Vertical joints of panel sheathing shall be permitted to occur over double studs, where adjoining panel edges are attached to separate studs with the required panel edge fastening schedule, and the adjacent studs are attached together with two rows of 10d box nails [3 inches by 0.128 inch (76.2 mm by 3.25 mm)] at 10 inches o.c. (254 mm).
3. Blocking at horizontal joints shall not be required in wall segments that are not counted as *braced wall panels*.
4. Where Method GB panels are installed horizontally, blocking of horizontal joints is not required.

## CHAPTER 7 WALL COVERING

### Exterior wall envelope.

**R703.1 General.** Exterior walls shall provide the building with a weather-resistant exterior wall envelope. The exterior wall envelope shall include flashing as described in Section R703.4.

**Exception:** Log walls designed and constructed in accordance with the provisions of ICC 400.

**R703.1.1 Exterior wall envelope.** The exterior wall envelope shall be installed in a manner such that water entering the assembly can drain to the exterior. The envelope shall consist of: an exterior veneer and a water-resistant barrier as required by Section R703.2; a space not less than  $\frac{1}{8}$  inch (3 mm) between the *water-resistive barrier* and the exterior veneer, and integrated flashings as required by Section R703.4. The required space shall be formed by the use of any noncorrosive furring strip, drainage mat or drainage board. The envelope shall provide proper integration of flashings with the *water-resistive barrier*, the drainage space provided and the exterior veneer or wall covering. These components combined shall provide a means of draining water entering the assembly to the exterior.

#### Exceptions:

1. A space is not required where the exterior wall covering is installed over a water-resistive barrier complying with Section R703.2 that is manufactured in a manner to enhance drainage and meets the 75-percent drainage efficiency requirement of ASTM E2273 or other recognized national standard.
2. A space is not required where windowsills are equipped with pan flashings that drain to the exterior surface of the wall covering in a through-wall fashion. All pan flashings shall be detailed within the construction documents and shall be of either a self-adhering membrane complying with AMAMA 711 or of an approved corrosion-resistant material or a combination thereof. Self-adhering membranes extending to the exterior surface of the wall covering shall be concealed with trims or other measures to protect from sunlight.
3. A space is not required for detached *accessory structures*.
4. A space is not required for additions, alterations or repairs where the new exterior wall covering is all of the following:
  - 4.1. Matching the existing exterior wall covering.
  - 4.2. Installed in the same plane as the existing wall covering without a change in direction or use of a control joint.
  - 4.3. Installed over a *water-resistive barrier* complying with Section R703.2.
5. The requirements of Section R703.1.1 shall not be required over concrete or masonry walls designed in accordance with Chapter 6 and flashed in accordance with Section R703.4 or R703.8.
6. Compliance with the requirements for a means of drainage, and the requirements of Sections R703.2 and R703.4, shall not be required for an exterior wall envelope that has been demonstrated to resist wind-driven rain through testing of the exterior wall envelope assembly, including joints, trim, exterior covering, penetrations, window and door openings and intersections with dissimilar materials, in accordance with ASTM E331 under the following conditions:
  - 6.1. Exterior wall envelope test assemblies shall include at least one opening, one control joint, one wall/eave interface and one wall sill. All tested openings and penetrations shall be representative of the intended end-use configuration.
  - 6.2. Exterior wall envelope test assemblies shall be at least 4 feet by 8 feet (1219 mm by 2438 mm) in size.
  - 6.3. Exterior wall assemblies shall be tested at a minimum differential pressure of 6.24 pounds per square foot (299 Pa).
  - 6.4. Exterior wall envelope assemblies shall be subjected to the minimum test exposure for a minimum of 2 hours.

The exterior wall envelope design shall be considered to resist wind-driven rain where the results of testing indicate that water did not penetrate control joints in the exterior wall envelope, joints at the perimeter of openings penetration or intersections of terminations with dissimilar materials.

## CHAPTER 9 ROOF ASSEMBLIES

### Photovoltaic shingles

**R905.16 Photovoltaic shingles.** The installation of *photovoltaic shingles* shall comply with the provisions of this section, Section R324 and *Electrical Code*.

**R905.16.1 Deck requirements.** *Photovoltaic shingles* shall be applied to a solid or closely fitted deck, except where the roof covering is specifically designed to be applied over spaced sheathing.

**R905.16.2 Deck slope.** *Photovoltaic shingles* shall be used only on roof slopes of two units vertical in 12 units horizontal (2:12) or greater.

**R905.16.3 Underlayment.** *Underlayment* shall comply with Section R905.1.1.

**R905.16.3.1 Ice barrier.** Where required, ice barriers shall comply with Section R905.1.2.

**R905.16.4 Material standards.** *Photovoltaic shingles* shall be listed and labeled in accordance with UL 1703.

**R905.16.5 Attachment.** *Photovoltaic shingles* shall be attached in accordance with the manufacturer's installation instructions.

**R905.16.6 Wind resistance.** *Photovoltaic shingles* shall be tested in accordance with procedures and acceptance criteria in ASTM D3161. *Photovoltaic shingles* shall comply with the classification requirements of Table R905.2.4.1 for the appropriate maximum basic wind speed. *Photovoltaic shingle* packaging shall bear a label to indicate compliance with the procedures in ASTM D3161 and the required classification from Table R905.2.4.1.

### Building-integrated photovoltaic panels

**R905.17 Building-integrated photovoltaic (BIPV) roof panels applied directly to the roof deck.** The installation of *BIPV roof panels* shall comply with the provisions of this section, Section R324 and *Electrical Code*.

**R905.17.1 Deck requirements.** *BIPV roof panels* shall be applied to a solid or closely fitted deck, except where the roof covering is specifically designed to be applied over spaced sheathing.

**R905.17.2 Deck slope.** *BIPV roof panels* shall be used only on roof slopes of two units vertical in 12 units horizontal (17-percent slope) or greater.

**R905.17.3 Underlayment.** *Underlayment* shall comply with Section 905.1.1.

**R905.17.3.1 Ice barrier.** Where required, an ice barrier shall comply with Section R905.1.2.

**R905.17.4 Ice barrier.** In areas where there has been a history of ice forming along the eaves causing a backup of water, as designated in Table R301.2(1), an ice barrier that consists of not less than two layers of *underlayment* cemented together or of a self-adhering polymer-modified bitumen sheet shall be used in lieu of normal *underlayment* and extend from the lowest edges of all roof surfaces to a point not less than 24 inches (610 mm) inside the exterior wall line of the building.

**Exception:** Detached accessory structures that do not contain conditioned floor area.

**R905.17.5 Material standards.** *BIPV roof panels* shall be listed and labeled in accordance with UL 1703.

**R905.17.6 Attachment.** *BIPV roof panels* shall be attached in accordance with the manufacturer's installation instructions.

**R905.17.7 Wind resistance.** *BIPV roof panels* shall be tested in accordance with UL 1897. *BIPV roof panel* packaging shall bear a label to indicate compliance with UL 1897.

### Roof recovering

**R908.3 Roof replacement.** Roof replacement shall include the removal of existing layers of roof coverings down to the roof deck.

**Exception:** Where the existing *roof assembly* includes an ice barrier membrane that is adhered to the roof deck, the existing ice barrier membrane shall be permitted to remain in place and covered with an additional layer of ice barrier membrane in accordance with Section R905.

**R908.3.1 Roof recover.** The installation of a new roof covering over an existing roof covering shall be permitted where any of the following conditions occur:

1. Where the new roof covering is installed in accordance with the roof covering manufacturer's approved instructions
2. Complete and separate roofing systems, such as standing-seam metal roof systems, that are designed to transmit the roof loads directly to the building's structural system and do not rely on existing roofs and roof coverings for support, shall not require the removal of existing roof coverings.
3. Metal panel, metal shingle and concrete and clay tile roof coverings shall be permitted to be installed over existing wood shake roofs where applied in accordance with Section R908.4.
4. The application of a new protective *roof coating* over an existing *protective roof coating*, metal roof panel, metal roof shingle, mineral surfaced roll roofing, built-up roof, modified bitumen roofing, thermoset and thermoplastic single-ply roofing and spray polyurethane foam roofing system shall be permitted without tear-off of existing roof coverings.

**R908.3.1.1 Roof recover not allowed.** A *roof recover* shall not be permitted where any of the following conditions occur:

1. Where the existing roof or roof covering is water soaked or has deteriorated to the point that the existing roof or roof covering is not adequate as a base for additional roofing.
2. Where the existing roof covering is slate, clay, cement or asbestos-cement tile.
3. Where the existing roof has **two** or more applications of any type of roof covering.

# CHAPTER 11 ENERGY EFFICIENCY

## Scope and additional measures.

### SECTION N1101 SCOPE

**N1101.1 General.** The provisions of this chapter regulate the exterior envelope, as well as the design, construction and selection of heating, ventilating and air-conditioning systems, lighting and piping insulation required for the purpose of effective conservation of energy within a building or structure governed by this code.

All conditioned spaces within residential buildings shall comply with Table N1101.1(1) and one additional measure from Table N1101.1(2).

#### Exceptions:

1. Application to existing buildings shall comply with Section N1101.2.
2. Application to additions shall comply with Section N1101.3.
3. Heated or cooled detached *accessory structures* that are not habitable shall meet the following envelope requirements without any additional measures: Walls: R-21/U-0.064; Roofs: R-38/U-0.027 (attic) or R-20 continuous insulation/U-0.048 (above deck); Windows: U-0.35; Opaque doors: U-0.70; Roll-up doors: U-0.50.

## Existing buildings.

**N1101.2 Application to existing buildings.** Alteration and repairs, historic buildings and change of use or occupancy to buildings, structures or portions thereof shall comply with the requirements in Sections N1101.2.1 through N1101.2.3.

**N1101.2.1 Alteration and repair.** Alterations and repairs affecting energy conservation measures shall conform to the requirements specified in this chapter.

Alterations or repairs which affect components of existing conditioned spaces regulated in this chapter, those components shall comply with this chapter.

**Exception:** The minimum component requirements as specified in Table N1101.2 may be used to the maximum extent practical.

**N1101.2.2 Historic buildings.** The building official may modify the specific requirements of this chapter for historic buildings and require in lieu thereof alternative requirements that will result in a reasonable degree of energy efficiency. This modification may be allowed for those buildings specifically designated as historically significant by the state historic preservation office(r) or by official action of a local government.

**N1101.2.3 Change of occupancy or use.** Definition of “change of use” for purposes of Section N1101.2.3 is a change of use in an existing residential building and shall include any of the following: any unconditioned spaces such as an attached garage, basement, porch, or canopy that are to become conditioned spaces; any unconditioned, inhabitable space that is to become conditioned space, such as a large attic.

**N1101.2.3.1 Change of use.** A building that changes use, without any changes to the components regulated in this chapter, is required to comply with Table N1101.2 to the greatest extent practical. Changes of use that are greater than 30 percent of the existing building heated floor area or more than 400 square feet (37 m<sup>2</sup>) in area, whichever is less, shall be required to select one measure from Table N1101.3.

**N1101.2.3.2 Change of occupancy.** Alteration and repair of conditioned nonresidential buildings, such as a small church or school, that are changing occupancy to residential *dwelling*s shall use Table N1101.2 to the greatest extent practical and select one measure from Table N1101.1(2), or Table N1101.3.

**Exception:** The minimum component requirements shall be disregarded when thermal performance calculations are completed for change of use to Group R-3 occupancy, when such calculations demonstrate similar performance to the requirements of Table N1101.2.

TABLE N1101.2  
EXISTING BUILDING COMPONENT REQUIREMENTS

BUILDING COMPONENTS	REQUIRED PERFORMANCE	EQUIV. VALUE
Wall insulation	U-0.083	R-15
Flat ceiling	U-0.025	R-49
Vaulted ceiling > 10 inches nominal rafter depth	U-0.040	R-25
Vaulted ceiling > 8 inches nominal rafter depth	U-0.047	R-21
Underfloor > 10 inches nominal joist depth	U-0.028	R-30
Underfloor > 8 inches nominal joist depth	U-0.039	R-25
Slab-edge perimeter	F-0.52	R-15
Windows	U-0.30	U-0.30
Skylights	<u>U-0.50</u>	<u>U-0.50</u>
Exterior doors	U-0.20	R-5
Exterior doors with > 2.5 ft <sup>2</sup> glazing	U-0.40	R-2.5
Forced air ducts	n/a	R-8

For SI: inch = 25.4 mm, 1 square foot = 0.0929 m<sup>2</sup>.



**TABLE N1101.1(1)  
PRESCRIPTIVE ENVELOPE REQUIREMENTS<sup>a</sup>**

BUILDING COMPONENT	STANDARD BASE CASE		LOG HOMES ONLY	
	Required Performance	Equiv. Value <sup>b</sup>	Required Performance	Equiv. Value <sup>b</sup>
Wall insulation—above grade	U-0.059 <sup>c</sup>	R-21 Intermediate <sup>c</sup>	Note d	Note d
Wall insulation—below grade <sup>e</sup>	C-0.063	R-15 <u>c.i.</u> /R-21	C-0.063	R-15/R-21
Flat ceilings <sup>f</sup>	U-0.021	R-49	U-0.020	R-49 A <sup>h</sup>
Vaulted ceilings <sup>g</sup>	U-0.033	R-30 Rafter or R-30A <sup>g, h</sup> Scissor Truss	U-0.027	R-38A <sup>h</sup>
Underfloors	U-0.033	R-30	U-0.033	R-30
Slab-edge perimeter <sup>m</sup>	F-0.520	R-15	F-0.520	R-15
Heated slab interior <sup>i</sup>	n/a	R-10	n/a	R-10
Windows <sup>j</sup>	<u>U-0.27</u>	<u>U-0.27</u>	<u>U-0.27</u>	<u>U-0.27</u>
Skylights	U-0.50	U-0.50	U-0.50	U-0.50
Exterior doors <sup>k</sup>	U-0.20	U-0.20	U-0.54	U-0.54
Exterior doors with > 2.5 ft <sup>2</sup> glazing <sup>l</sup>	U-0.40	U-0.40	U-0.40	U-0.40

For SI: 1 inch = 25.4 mm, 1 square foot = 0.0929 m<sup>2</sup>, 1 degree = 0.0175 rad, n/a = not applicable.

- a. As allowed in Section N1104.1, thermal performance of a component may be adjusted provided that overall heat loss does not exceed the total resulting from conformance to the required U-factor standards. Calculations to document equivalent heat loss shall be performed using the procedure and approved U-factors contained in Table N1104.1(1).
- b. R-values used in this table are nominal for the insulation only in standard wood-framed construction and not for the entire assembly.
- c. Wall insulation requirements apply to all exterior wood-framed, concrete or masonry walls that are above grade. This includes cripple walls and rim joist areas. Nominal compliance with R-21 insulation and Intermediate Framing (N1104.5.2) with insulated headers.
- d. The wall component shall be a minimum solid log or timber wall thickness of 3.5 inches.
- e. Below-grade wood, concrete or masonry walls include all walls that are below grade and do not include those portions of such wall that extend more than 24 inches above grade. R-21 for insulation in framed cavity; R-15 continuous insulation.
- f. Insulation levels for ceilings that have limited attic/rafter depth such as dormers, bay windows or similar architectural features totaling not more than 150 square feet in area may be reduced to not less than R-21. When reduced, the cavity shall be filled (except for required ventilation spaces). R-49 insulation installed to minimum 6-inches depth at top plate at exterior of structure to achieve U-factor.
- g. Vaulted ceiling surface area exceeding 50 percent of the total heated space floor area shall have a U-factor no greater than U-0.026 (equivalent to R-38 rafter or scissor truss with R-38 advanced framing).
- h. A = Advanced frame construction. See Section N1104.6.
- i. Heated slab interior applies to concrete slab floors (both on and below grade) that incorporate a radiant heating system within the slab. Insulation shall be installed underneath the entire slab.
- j. Sliding glass doors shall comply with window performance requirements. Windows exempt from testing in accordance with Section NF1111.2, Item 3 shall comply with window performance requirements if constructed with thermal break aluminum or wood, or vinyl, or fiberglass frames and double-pane glazing with low-emissivity coatings of 0.10 or less. Buildings designed to incorporate passive solar elements may include glazing with a U-factor greater than 0.35 by using Table N1104.1(1) to demonstrate equivalence to building thermal envelope requirements.
- k. A maximum of 28 square feet of exterior door area per dwelling unit can have a U-factor of 0.54 or less.
- l. Glazing that is either double pane with low-e coating on one surface, or triple pane shall be deemed to comply with this requirement.
- m. Minimum 24-inch horizontal or vertical below-grade.

**TABLE N1101.1(2)  
ADDITIONAL MEASURES**

1	<b>HIGH EFFICIENCY HVAC SYSTEM<sup>a</sup></b> a. Gas-fired furnace or boiler AFUE 94 percent, or b. Air source heat pump HSPF 10.0/14.0 SEER cooling, or c. Ground source heat pump COP 3.5 or Energy Star rated
2	<b>HIGH EFFICIENCY WATER HEATING SYSTEM</b> a. Natural gas/propane water heater with minimum UEF 0.90, or b. Electric heat pump water heater with minimum 2.0 COP, or c. Natural gas/propane tankless/instantaneous heater with minimum 0.80 UEF and Drain Water Heat Recovery Unit installed on minimum of one shower/tub-shower
3	<b>WALL INSULATION UPGRADE</b> Exterior walls—U-0.045/R-21 conventional framing with R-5.0 continuous insulation
4	<b>ADVANCED ENVELOPE</b> Windows—U-0.21 (Area weighted average), and Flat ceiling <sup>b</sup> —U-0.017/R-60, and Framed floors—U-0.026/R-38 or slab edge insulation to F-0.48 or less (R-10 for 48"; R-15 for 36" or R-5 fully insulated slab)
5	<b>DUCTLESS HEAT PUMP</b> For dwelling units with all-electric heat provide: Ductless heat pump of minimum HSPF 10 in primary zone replaces zonal electric heat sources, and Programmable thermostat for all heaters in bedrooms
6	<b>HIGH EFFICIENCY THERMAL ENVELOPE UA<sup>c</sup></b> Proposed UA is 8 percent lower than the code UA
7	<b>GLAZING AREA</b> Glazing area, measured as the total of framed openings is less than 12 percent of conditioned floor area
8	<b>3 ACH AIR LEAKAGE CONTROL AND EFFICIENT VENTILATION</b> Achieve a maximum of 3.0 ACH50 whole-house air leakage when third-party tested and provide a whole-house ventilation system including heat recovery with a minimum sensible heat recovery efficiency of not less than 66 percent.

For SI: 1 square foot = 0.093 m<sup>2</sup>, 1 watt per square foot = 10.8 W/m<sup>2</sup>.

- Appliances located within the building thermal envelope shall have sealed combustion air installed. Combustion air shall be ducted directly from the outdoors.
- The maximum vaulted ceiling surface area shall not be greater than 50 percent of the total heated space floor area unless vaulted area has a U-factor no greater than U-0.026.
- In accordance with Table N1104.1(1), the Proposed UA total of the Proposed Alternative Design shall be a minimum of 8 percent less than the Code UA total of the Standard Base Case.

## Large and small additions.

**N1101.3 Additions.** Additions to existing buildings or structures may be made without making the entire building or structure comply if the new additions comply with the requirements of this chapter.

**N1101.3.1 Large additions.** Additions that are equal to or more than 600 square feet (55 m<sup>2</sup>) in area shall be required to comply with Table N1101.1(2).

**N1101.3.2 Small additions.** Additions that are less than 600 square feet (55 m<sup>2</sup>) in area shall be required to select one measure from Table N1101.1(2) or comply with Table N1101.3.

**Exception:** Additions that are less than **225** square feet (**20.9** m<sup>2</sup>) in area shall not be required to comply with Table N1101.1(2) or Table N1101.3.

**N1101.4 Information on plans and specifications.** Plans and specifications shall show in sufficient detail all pertinent data and features of the building and the equipment and systems as herein governed, including, but not limited to: exterior envelope component materials; R-values of insulating materials; fenestration U-factors; HVAC equipment efficiency performance and system controls; lighting; an additional measure from Table N1101.1(2); and the other pertinent data to indicate compliance with the requirements of the chapter.

**TABLE N1101.3  
SMALL ADDITION ADDITIONAL MEASURES (select one)**

1	Increase the ceiling insulation of the existing portion of the home as specified in Table N1101.2.
2	Replace all existing single-pane wood or aluminum windows to the U-factor as specified in Table N1101.2
3	Insulate the <u>existing</u> floor, <u>crawl space</u> or <u>basement wall</u> systems as specified in Table N1101.2 and install 100 percent of permanently installed lighting fixtures as CFL, LED or linear fluorescent, or a minimum efficacy of 40 lumens per watt as specified in Section N1107.2.
4	Test the entire dwelling with a blower door and exhibit no more than <u>4.5</u> air changes per hour @ 50 Pascals.
5	Seal and performance test the duct system.
6	Replace existing <u>80</u> -percent AFUE or less gas furnace with a 92-percent AFUE or greater system.
7	Replace existing electric radiant space heaters with a ductless mini split system with a minimum HSPF of 10.0.
8	Replace existing electric forced air furnace with an air source heat pump with a minimum HSPF of 9.5.
9	Replace existing water heater with a water heater meeting: <u>Natural gas/propane water heater with minimum UEF 0.90, or</u> <u>Electric heat pump water heater with minimum 2.0 COP.</u>

## Definitions.

**BUILDING THERMAL ENVELOPE.** That element of a building which encloses conditioned spaces through which thermal energy may be transmitted to or from the exterior or to or from unconditioned spaces.

**CONDITIONED SPACE.** A space within the building, separated from unconditioned space by the [building thermal envelope](#), which by introduction of conditioned air, by heated and/or cooled surfaces, or by air or heat transfer from directly conditioned spaces is maintained at temperatures of 55°F (13°C) or higher for heating and/or 85°F (29.4°C) or below for cooling. (Enclosed corridors between conditioned spaces shall be considered as conditioned space. Spaces where temperatures fall between this range by virtue of ambient conditions shall not be considered as conditioned space.)

**EXTERIOR ENVELOPE.** See “Building [thermal envelope](#).”

**HIGH-EFFICIENCY LIGHT SOURCE.** Compact fluorescent lamps, T-8 or smaller diameter linear fluorescent lamps, LED lamps, fixture-integrated illumination [devices, or lamps with an efficacy not less than 65 lumens per watt for each lamp or luminaires with an efficacy not less than 45 lumens per watt per each luminaire](#).

## Exterior envelope requirements.

### SECTION N1104 EXTERIOR ENVELOPE REQUIREMENTS

**N1104.1 General.** This section provides, minimum requirements for exterior envelope construction.

The exterior building envelope shall comply with Table N1101.1(1) or shall be demonstrated using Table N1104.1(1). The requirements specified in Table N1101.1(2) shall apply to both Tables N1101.1(1) and N1104.1(1).

Buildings designed to incorporate passive solar elements may use Table N1104.1(1) to demonstrate building [thermal envelope](#) requirements in this code, in addition to requirements specified in Table N1101.1(2).

**N1104.2 Insulation materials.** Insulation materials shall be installed in accordance with manufacturer’s listing and installation instructions and this code. Insulation *R*-values shall be specified as required in 16 CFR Ch. I (1-1-91 Edition) Part 460—Labeling and Advertising of Home Insulation. Cellulose insulation shall conform to Interim Safety Standard for Cellulose Insulation (16 CFR Part 1209) issued by the Consumer Product Safety Commission July 6, 1979 (44FR 39938). Foam plastic shall be as specified in Section R316.

**N1104.2.1 Insulation clearance restriction.** Blown, poured, batt and spray-on type insulation applied from above the ceiling level shall be limited to vented attic spaces where the roof slope is 4 units vertical in 12 units horizontal (33.3-percent slope) or greater and there is at least 44 inches (1118 mm) of headroom at the roof ridge. (Clear headroom is defined as the distance from the top of the bottom chord of the truss or ceiling joists to the underside of the roof sheathing.) Netted or other applications that allow for verification of insulation application shall be allowed for low-slope roofs.

**N1104.2.2 Batt-type insulation.** Batt-type insulation shall be installed flush against the warm side of the cavity insofar as practicable.

**N1104.2.3 Insulation protection.** Insulation exposed to the exterior shall be protected from physical and solar damage.

**N1104.2.4 Clearances.** Recessed light fixtures shall be IC-labeled for direct insulation contact.

Thermal insulation shall not be installed within 3 inches (76 mm) of any metal chimney or gas vent that is not listed for insulation clearances.

A permanent sleeve of fine wire mesh screen, sheet metal or other noncombustible material shall be installed to maintain the required clearances.

**N1104.2.5 Baffles.** Baffles of a durable rigid material shall be provided to prevent obstruction of vent openings and to deflect incoming air above the surface of porous insulation so as to prevent wind-washing and blowing of loose material. Thermal insulation shall not be installed in a manner that would obstruct openings required for attic ventilation.

**N1104.2.6 Below-grade exterior insulation.** Below-grade exterior insulation shall meet the following conditions:

1. The insulation shall be a material that is approved for below-grade applications in wet environments.
2. Insulation shall be installed from the top of the footing to the top of the concrete basement wall.
3. Insulation shall be adequately protected from the elements (ultraviolet and mechanical) in accordance with manufacturer’s specifications.
4. The top of the insulation shall be installed in a manner to allow water runoff and prevent pooling.

**N1104.2.7 Recessed lighting fixtures.** Recessed lighting fixtures installed within the building [thermal envelope](#) shall meet one of the following requirements.

1. Type IC-rated, manufactured with no penetrations between the inside of the recessed fixture and ceiling cavity, and the annular space between the ceiling cutout and lighting fixture shall be sealed.
2. Type IC-rated in accordance with ASTM E283 with no more than 2.0 cubic feet per minute (cfm) (0.944 L/s) air movement from the conditioned space to the ceiling cavity at 1.57 psi pressure (75 Pa) difference shall be labeled and the annular space between the ceiling cutout and lighting fixture shall be sealed.
3. Type IC-rated installed inside a sealed box constructed from a minimum 0.5-inch-thick (12.7 mm) gypsum wallboard or constructed from a preformed polymeric vapor retarder or other air-tight assembly manufactured for this purpose.

**N1104.2.8 Doors and pull-down stairs to unconditioned spaces.** Service doors between unconditioned and conditioned spaces shall meet the thermal requirements of Sections N1104.2.9.1 and N1104.2.9.2.

**N1104.2.8.1 Vertical doors.** *U*-factors for vertical doors providing access from conditioned to unconditioned spaces shall comply with the exterior door provisions of Table N1101.1(1).

**N1104.2.8.2 Pull-down stairs.** Horizontal pull-down stair-type access hatches in ceiling assemblies that provide access from conditioned to unconditioned spaces shall have a maximum average  $U$ -factor of  $U-0.10$  or an  $R$ -value of not less than  $R-10$ , have a net area of the framed opening not exceeding 13.5 square feet, and have the perimeter of the hatch weatherstripped.

**N1104.3 Exterior doors.** Doors shall be tested according to the requirements of Section N1104.4. When calculating the energy performance of the exterior envelope, the area of doors shall be the actual unit size.

**Exceptions:**

1. Unglazed doors that are not tested according to the requirements of Section N1104.4 shall be assigned a default  $U$ -value of 0.54.
2. Sliding glass doors and swinging glass doors shall meet the specifications for windows and shall be treated as such.
3. Doors that incorporate glazed areas more than 2.5 square feet ( $0.23 \text{ m}^2$ ) in area shall be considered exterior doors with greater than or equal to 2.5 square feet ( $0.23 \text{ m}^2$ ) glazing. Doors shall meet the air leakage requirements of Section N1104.8.

**N1104.4 Windows.** All windows installed in Oregon shall meet the requirements of Part III, Fenestration Standard.

1. Decorative or unique architectural feature glazing not exceeding 1 percent of the heated space floor area is exempt from thermal performance requirements and does not need to be included in Table N1104.1(1) calculations.
2. Glass block assemblies may use a  $U$ -factor of 0.51.
3. The  $U$ -factor for windows may be a weighted average of total window area when all other building [thermal](#) envelope measures are in compliance with performance requirements specified in this code. This calculation shall be provided to the building official and the windows that are less than required for prescriptive compliance shall be identified on the plans.

**N1104.4.1 Thermal performance labeling.** All fenestrations shall have labels. The labels shall be a National Fenestration Rating Council (NFRC) certified product or a state-approved label for windows produced in low volume. All labeling shall conform to the following requirements:

1. Be imprinted and not handwritten.
2. Face the interior of the room.
3. List the  $U$ -factor.
4. Be attached to the window until the building inspector inspects and verifies the labeling.

**Exceptions:**

1. Labeling is not required for decorative or unique architectural feature glazing not exceeding 1 percent of the heated space floor area.
2. Portions of labels for windows produced in low volume may be handwritten.

**N1104.4.2 Combined products.** When different window types are combined, mullered together by the manufacturer or manufactured to fit a framed rough opening, a single label may be used.

**Exception:** A solarium shall have one label providing a description of each of the glazed surfaces, such as the front, overhead and each side.

**TABLE N1104.1(1)  
RESIDENTIAL THERMAL PERFORMANCE CALCULATIONS**

BUILDING COMPONENTS <sup>b</sup>	STANDARD BASE CASE <sup>a</sup>			PROPOSED A		ALTERNATIVE	
	Areas <sup>c</sup>	<i>U</i> -factor	Areas x <i>U</i>	<i>R</i> -value <sup>d</sup>	Areas <sup>c</sup>	<i>U</i> -factor <sup>e</sup>	Areas x <i>U</i>
Flat ceilings		0.021					
Vaulted ceilings <sup>f</sup>		0.033					
Conventional wood-framed walls		0.059					
Underfloor		0.033					
Slab edge		F = 0.52 <sup>g</sup>					
Below-grade walls		C = 0.063 <sup>g</sup>					
Windows		<u>0.27</u>					
Skylights		0.50					
Exterior doors <sup>h</sup>		0.2					
Doors with > 2.5 ft <sup>2</sup> glazing		0.4					
CODE UA =				Proposed UA <sup>i</sup> =			

- a. Base path 1 represents Standard Base Case from Table N1101.1(1). *U*-factors shall be adjusted to match selected Envelope Measure [Table N1101.1(2)].
- b. Performance trade-offs are limited to those listed in Column 1. Heat plant efficiency, duct insulation levels, passive and active solar heating, air infiltration and similar measures including those not regulated by code must not be considered in this method of calculation.
- c. Areas from plan take-offs. All areas must be the same for both Standard Base Case and Proposed Alternate. The vaulted ceiling surface area for Standard Base Case must be the actual surface area from the plan take-off not to exceed 50 percent of the total heated space floor area. Any roof areas in excess of 50 percent for Base Case must be entered at U-0.021 (R-49) with "Flat ceilings" area.
- d. Minimum component requirements insofar as practicable: Walls R-15/U-0.080; Floors R-21/U-0.047; Flat Ceilings R-38/U-0.031; Vaults R-21/U-0.055; Below-Grade Wood, Concrete or Masonry Walls R-15/C-0.069; Slab Edge R-10/F-0.52; Duct Insulation R-8. *R*-values used in this table are nominal, for the insulation only and not for the entire assembly. Window and skylight *U*-values shall not exceed 0.65 (CL65). A single door not to exceed 28 square feet (2.6 m<sup>2</sup>) per dwelling unit is permitted to be excluded from the thermal performance calculations. All other Door-values shall not exceed 0.54 (Nominal R-2).
- e. *U*-factors for wood-framed ceilings, walls and floor assemblies shall be as specified in Table N1104.1(2). *U*-factors for other assemblies, which include steel framing, brick or other masonry, stucco, etc., shall be calculated using ASHRAE *Handbook of Fundamentals* procedures.
- f. Vaulted area, unless insulated to R-38, 0.027, shall not exceed 50 percent of the total heated space floor area.
- g. F = The heat loss coefficient, Btu/hr\*ft<sup>2</sup>\*°F per foot of perimeter. C = the heat loss coefficient Btu/hr\*ft<sup>2</sup>\*°F per square foot of underground wall.
- h. A maximum of 28 square feet of exterior door area per dwelling unit can have a *U*-factor of 0.54 or less. Default *U*-factor for an unglazed wood door is 0.54.
- i. Proposed UA must be less than or equal to CODE UA. For compliance with Envelope Measure 6, the Proposed UA must be a minimum of 8 percent less than the CODE UA.



**TABLE N1104.1(2)  
APPROVED DEFAULT U-FACTORS**

FLAT CEILING <sup>a</sup>			EXTERIOR WALLS <sup>a</sup>			
Insulation	Type	U-Factor	Insulation	Insulation Sheathing	Framing	U-Factor
R-38	Conventional framing	0.027	R-15	0	Conventional framing	0.083
R-38	Advanced framing <sup>c</sup>	0.026	R-15	0	Intermediate framing <sup>b</sup>	0.078
R-49	Conventional framing	0.021	R-19	0	Conventional framing	0.067
R-49	Advanced framing <sup>c</sup>	0.020	R-19	0	Intermediate framing <sup>b</sup>	0.063
R-60	Conventional framing	0.017	R-19	0	Advanced framing <sup>d</sup>	0.062
VAULTED CEILING <sup>a</sup>			R-21	0	Conventional framing	0.063
Insulation	Type	U-Factor	R-21	0	Intermediate framing <sup>b</sup>	0.059
R-21	Rafter framing	0.050	R-21	0	Advanced framing <sup>d</sup>	0.057
R-30	Rafter framing	0.032	R-13	3.5 <sup>e</sup>	Conventional framing	0.065
R-38	Rafter framing	0.026	R-13	5 <sup>e</sup>	Conventional framing	0.059
R-21	Scissors truss	0.052	R-13	7 <sup>e</sup>	Conventional framing	0.053
R-30	Scissors truss	0.034	R-13	3.5 <sup>e</sup>	Advanced framing <sup>d</sup>	0.062
R-38	Scissors truss	0.027	R-13	5 <sup>e</sup>	Advanced framing <sup>d</sup>	0.056
R-49	Scissors truss	0.021	R-13	7 <sup>e</sup>	Advanced framing <sup>d</sup>	0.050
R-30	Advanced scissors truss <sup>c</sup>	0.032	R-15	3.5 <sup>e</sup>	Conventional framing	0.062
R-38	Advanced scissors truss <sup>c</sup>	0.026	R-15	5 <sup>e</sup>	Conventional framing	0.056
R-49	Advanced scissors truss <sup>c</sup>	0.020	R-15	7 <sup>e</sup>	Conventional framing	0.050
EPS FOAM CORE PANEL VAULTED CEILING <sup>a</sup>			R-15	3.5 <sup>e</sup>	Advanced framing <sup>d</sup>	0.057
Insulation	Type	U-Factor	R-15	5 <sup>e</sup>	Advanced framing <sup>d</sup>	0.052
R-29	8 <sup>1</sup> / <sub>4</sub> " EPS foam core panel	0.034	R-15	7 <sup>e</sup>	Advanced framing <sup>d</sup>	0.047
R-37	10 <sup>1</sup> / <sub>4</sub> " EPS foam core panel	0.027	R-19	3.5 <sup>e</sup>	Conventional framing	0.052
R-44	12 <sup>1</sup> / <sub>4</sub> " EPS foam core panel	0.023	R-19	5 <sup>e</sup>	Conventional framing	0.048
FLOORS <sup>a</sup>			R-19	7 <sup>e</sup>	Conventional framing	0.044
Insulation	Type	U-Factor	R-19	3.5 <sup>e</sup>	Advanced framing <sup>d</sup>	0.049
R-21	Underfloor	0.046	R-19	5 <sup>e</sup>	Advanced framing <sup>d</sup>	0.046
R-25	Underfloor	0.039	R-19	7 <sup>e</sup>	Advanced framing <sup>d</sup>	0.042
R-30	Underfloor	0.033	R-21	3.5 <sup>e</sup>	Conventional framing	0.049
R-38	Underfloor	0.026	R-21	5 <sup>e</sup>	Conventional framing	0.045
SLAB-ON-GRADE			R-21	7 <sup>e</sup>	Conventional framing	0.041
Insulation	Type	F-Factor <sup>f</sup>	R-21	3.5 <sup>e</sup>	Advanced framing <sup>d</sup>	0.046
R-10	Slab edge 24"	0.54	R-21	5 <sup>e</sup>	Advanced framing <sup>d</sup>	0.043
R-15	Slab edge 24"	0.52	R-21	7 <sup>e</sup>	Advanced framing <sup>d</sup>	0.039
EPS FOAM CORE PANEL EXTERIOR WALLS			R-14.88	4 <sup>1</sup> / <sub>2</sub> " EPS foam core panel	0.059	
Insulation	Type	U-Factor	R-22.58	6 <sup>1</sup> / <sub>4</sub> " EPS foam core panel	0.040	
R-14.88	4 <sup>1</sup> / <sub>2</sub> " EPS foam core panel	0.059	R-29.31	8 <sup>1</sup> / <sub>4</sub> " EPS foam core panel	0.031	
R-22.58	6 <sup>1</sup> / <sub>4</sub> " EPS foam core panel	0.040				
R-29.31	8 <sup>1</sup> / <sub>4</sub> " EPS foam core panel	0.031				
BELOW GRADE WALLS						
Insulation	Type	C-Factor				
R-10 c.i.	R-10 continuous insulation	0.085				
R-15 c.i.	R-15 continuous insulation	0.063				
R-13	R-13 cavity and air space	0.080				
R-21	R-21 cavity and air space	0.063				

For SI: 1 inch = 25.4 mm.

- U-factors are for wood-framed construction. U-factors for other assemblies which include steel framing, brick or other masonry, stucco, etc., shall be calculated using standard ASHRAE *Handbook of Fundamentals* procedures.
- Intermediate framing consists of wall studs placed at a minimum 16 inches on center with insulated headers. Voids in headers shall be insulated with rigid insulation having a minimum R-value of 4 per 1-inch (25.4 mm) (W/m<sup>3</sup>-k) thickness.
- Advanced framing construction for ceilings as defined in Section N1104.6.
- Advanced framing construction for walls as defined in Section N1104.5.1
- Insulation sheathing shall be rigid insulation material, installed continuously over entire exterior or interior of wall (excluding partition walls).
- F-factor is heat loss coefficient in Btu/hr\*ft<sup>2</sup>\*°F per lineal foot of concrete slab perimeter for 24 inches below-grade.

**N1104.4.3 Air leakage requirements.** Air infiltration rates for all exterior windows, swinging doors and sliding glass doors shall be certified in accordance with ASTM E283, *Standard Test Methods for Rate of Air Leakage through Exterior Windows, Curtain Walls and Doors Under Specified Pressure Differences Across the Specimen*. Tests shall be conducted at a differential pressure of 1.57 pounds per square foot (75 Pa) [equivalent to 25 mph (40 km/h) wind condition].

1. Windows—0.37 cubic feet per minute (cfm) per foot (0.17 L/s per m) of sash crack.
2. Swinging doors—0.37 cfm per square foot (0.17 L/s per m<sup>2</sup>) of door area.
3. Sliding doors—0.37 cfm per square foot (0.17 L/s per m<sup>2</sup>) of door area.

**Exception:** Site-built windows.

**N1104.4.4 Alterations.** New windows shall have a maximum *U*-factor as required by Table N1101.1(1).

**Exceptions:**

1. Decorative or unique architectural feature glazing not exceeding 1 percent of the heated space floor area may be exempt from thermal performance requirements and Table N1104.1(1) calculations.
2. Where necessary to retain architectural consistency with remaining windows in the building, new windows shall have a maximum *U*-value of 0.65.

## Advanced and intermediate framing.

### N1104.5 Walls.

**N1104.5.1 Advanced framing for walls.** Advanced framing for walls is an optional construction method. Advanced framing, when used to qualify a design under the requirements of Table N1104.1(1), shall meet the following requirements:

1. Walls. Walls shall be framed with 2 × studs at 24 inches (610 mm) on center and shall include the following, as detailed in Items 2 and 3.
2. Corners and intersections. Exterior wall and ceiling corners shall be fully insulated through the use of three-stud corners configured to allow full insulation into the corner, or two-stud corners and drywall backup clips or other *approved* technique. Intersections of interior partition walls with exterior walls shall be fully insulated through the use of single backer boards, mid-height blocking with drywall clips or other approved technique.
3. Headers. Voids in headers 1 inch (25.4 mm) to 2 inches (51 mm) in thickness shall be insulated with insulation that has a value of R-4 or greater per 1-inch (25.4 mm) thickness. Voids in headers greater than 2 inches (51 mm) in depth shall be insulated to a minimum level of R-10. Nonstructural headers (such as in gable-end walls) shall be eliminated and replaced with insulation to achieve thermal performance levels equivalent to the surrounding area

**N1104.5.2 Intermediate framing for walls.** Intermediate framing for walls is an optional construction method. Intermediate framing, when used to achieve improved wall performance under the requirements of Table 1101.1(1) or Table N1104.1(2), shall meet the following requirements:

1. Walls. Walls shall be framed with 2 × studs at 16 inches (406 mm) on center and shall include the following, as detailed in Items 2 and 3.
2. Corners and intersections. Exterior wall and ceiling corners shall be fully insulated through the use of three-stud corners configured to allow full insulation into the corner, or two-stud corners and drywall backup clips or other approved technique. Intersections of interior partition walls with exterior walls shall be fully insulated through the use of single backer boards, mid-height blocking with drywall clips or other approved technique.
3. Headers. Voids in headers 1 inch (25.4 mm) to 2 inches (51 mm) in thickness shall be insulated with insulation that has a value of R-4 or greater per 1 inch (25.4 mm) thickness. Voids in headers greater than 2 inches (51 mm) in depth shall be insulated to a minimum level of R-10. Nonstructural headers (such as in gable-end walls) shall be eliminated and replaced with insulation to achieve thermal performance levels equivalent to the surrounding area.

**N1104.5.3 Below-grade walls.** Walls enclosing heated spaces below grade shall be insulated from the bottom of the above-grade subfloor downward to the top of the below-grade finished floor.

**N1104.6 Roof/ceiling: advanced framing for ceilings.** Advanced framing for ceilings is an optional construction method. Advanced framing, when used to qualify a design under the requirements of Section N1104.1, shall meet the following requirements.

Framing techniques shall be used in attics and ceilings to provide full insulating value to the outside of exterior walls. This shall be accomplished through the use of extra-depth or oversized trusses, double rafters, special insulation components installed at the edge of the wall, or other approved combinations of framing and insulation. The entire surface of the exterior ceiling shall be insulated to the required value including attic hatches, structural members, electrical fixtures (where allowed by the code) and plumbing penetrations.

**N1104.7 Slab-on-grade floors.** For slab-on-grade floors, the perimeter of the floor shall be insulated.

The insulation shall extend downward from the top of the slab for a minimum of 24 inches (610 mm) or downward to the bottom of the slab, then horizontally beneath the slab for a minimum total distance of 24 inches (610 mm).

**Exception:** For monolithic slabs, the insulation shall extend downward from the top of the slab to the bottom of the thickened edge.

**N1104.7.1 Slab-on-grade floors with hydronic heat.** For slab-on-grade floors that incorporate hydronic heating, in addition to perimeter insulation, the entire underside of slab shall be insulated to R-10.

## Air sealing requirements.

**N1104.8 Air leakage.** The building thermal envelope shall be constructed to limit air leakage in accordance with this section.

**N1104.8.1 Air barriers.** A continuous air barrier shall be installed and fully aligned with the building thermal envelope on every vertical portion of air-permeable insulation and on the warm side of horizontal, air-permeable insulation. Air-permeable insulation shall not be used as a sealing material.

**Exception:** Unvented attics, continuous insulation walls and similar conditions where an impermeable insulation layer forms an air barrier.

**N1104.8.2 Sealing required.** Exterior joints around window and door frames, between wall cavities and window or door frames, between walls and foundation, between walls and roof, between wall panels, at penetrations or utility services through walls, floors and roofs and all other openings in the exterior envelope shall be sealed in a manner approved by the *building official*.

Sealing for the purpose of creating a continuous air barrier shall be in accordance with the applicable requirements of Table N1104.8, or the dwelling shall be tested to demonstrate a blower door result not greater than 4.0 ACH50.

**N1104.8.2.1 Top plate sealing.** At all walls in contact with vented attics, the wall covering (gypsum board or other) shall be sealed to the top plate with caulk, sealant, gasket or other approved material.

**N1104.9 Moisture control.** To ensure the effectiveness of insulation materials and reduce the hazard of decay and other degradation due to condensation within the structure, moisture-control measures shall be included in all buildings and structures or portions thereof regulated by this chapter.

**N1104.9.1 Vapor retarders.** Vapor retarders shall be installed in accordance with Section R318.

**N1104.9.2 Ground cover.** A ground cover shall be installed in the crawl space for both new and existing buildings when insulation is installed. Ground cover shall be installed in accordance with Chapter 4.

**TABLE N1104.8  
AIR BARRIER INSTALLATION AND AIR SEALING REQUIREMENTS**

COMPONENT	AIR BARRIER CRITERIA
General requirements	A continuous air barrier shall be installed in alignment with the building thermal envelope.
	Breaks or joints in the air barrier shall be sealed.
Ceiling/attic	The air barrier in any dropped ceiling or soffit shall be aligned with the insulation and any gaps in the air barrier shall be sealed.
	Access openings, drop-down stairs, or knee wall doors to unconditioned attic spaces shall be gasketed and sealed.
Walls	The junction of the foundation and sill plate shall be sealed.
	The junction of the top plate and the top of interior walls shall be sealed between wall cavities and windows or door frames.
	All penetrations or utility services through the top and bottom plates shall be sealed.
	Knee walls shall be sealed.
Windows, skylights and doors	The space between framing and skylights, and the jambs of windows and doors shall be sealed.
Rim/band joists	Rim/band joists shall be a part of the thermal envelope and have a continuous air barrier.
Floors Including cantilevered floors and floors above garages	The air barrier shall be installed at any exposed edge of insulation.
Crawl space walls	Exposed earth in unvented crawl spaces shall be covered with a Class I vapor retarder with overlapping joints taped.
Shafts, penetrations	Duct shafts, utility penetrations and flue shafts opening to exterior or unconditioned space shall be sealed.
Garage separation	Air sealing shall be provided between the garage and conditioned spaces.
Recessed lighting	Recessed light fixtures installed in the building thermal envelope shall be sealed to the finished surface.
Shower/tub on exterior walls	The air barrier installed at exterior walls adjacent to showers and tubs shall separate the wall from the shower or tub.
Electrical/phone box on exterior walls	The air barrier shall be installed behind electrical and communication boxes. Alternatively, air-sealed boxes shall be installed.
HVAC register boots	HVAC supply and return register boots that penetrate building thermal envelope shall be sealed to the subfloor, wall covering or ceiling penetrated by the boot.

## Insulation and installation of ducts.

### SECTION N1105 HEATING, VENTILATING AND AIR-CONDITIONING SYSTEMS

**N1105.1 General.** This section provides minimum requirements for heating, ventilating and air-conditioning systems.

**N1105.2 Insulation of ducts.** All new duct systems or new portions of duct systems exposed to unconditioned spaces, and buried ductwork within insulation that meets the exception to Section N1105.3, shall be insulated to minimum R-8.

#### Exceptions:

1. The replacement or addition of a furnace, air conditioner or heat pump shall not require existing ducts to be insulated to current code.
2. Exhaust and intake ductwork.

**N1105.3 Installation of ducts.** All new duct systems and air handling equipment and appliances shall be located fully within the building thermal envelope.

#### Exceptions:

1. Ventilation intake ductwork and exhaust ductwork.
2. Up to 5 percent of the length of an HVAC system ductwork shall be permitted to be located outside of the thermal envelope.
3. Ducts deeply buried in insulation in accordance all of the following:
  - 3.1. Insulation shall be installed to fill gaps and voids between the duct and the ceiling, and a minimum of R-19 insulation shall be installed above the duct between the duct and unconditioned attic.
  - 3.2. Insulation depth marker flags shall be installed on the ducts every 10 feet (3048 mm) or as approved by the building official.

**N1105.4 HVAC controls.** All heating, ventilating and air-conditioning systems shall be provided controls as specified herein.

**N1105.4.1 Temperature.** Each heating, ventilating and air-conditioning system shall be provided with at least one thermostat for the regulation of temperature. Each thermostat shall be capable of being set from 55°F to 75°F (13°C to 24°C) where used to control heating only and from 70°F to 85°F (21°C to 29°C) where used to control cooling only. Where used to control both heating and cooling, it shall be capable of being set from 55°F to 85°F (13°C to 29°C) and shall be capable of operating the system heating and cooling in sequence. It shall be capable of providing a temperature range of at least 5°F (-15°C) within which the supply of heating and cooling energy to the zone is shut off or reduced to a minimum.

**N1105.4.2 Humidity.** If a heating, ventilating and air-conditioning system is equipped with a means for adding moisture to maintain specific selected relative humidity in spaces or zones, a humidistat shall be provided. This device shall be capable of being set to prevent new energy from being used to produce space relative humidity above 30 percent. Where a humidistat is used in a heating, ventilating and air-conditioning system for controlling moisture removal to maintain

specific selected relative humidity in spaces or zones, it shall be capable of being set to prevent new energy from being used to produce a space-relative humidity below 60 percent.

**N1105.4.3 Temperature zoning.** Each separate heating, ventilating and air-conditioning system shall be provided at least one thermostat for regulation of space temperature. In addition, a readily accessible manual or automatic means shall be provided to partially restrict or shut off the heating or cooling input to each zone or floor, excluding unheated or noncooled basements and garages.

**N1105.4.4 Setback and shutoff.** The thermostat, or an alternative means such as switch or clock, shall provide a readily accessible manual or automatic means for reducing the energy required for heating and cooling during periods of nonuse or reduced need.

#### Exceptions:

1. Where it can be shown that setback or shutdown will not result in a decrease in overall building energy.
2. Equipment with full-load demand of 2 kilowatts (6.826 Btu/h) or less may be controlled by readily accessible off-hour controls.

Lowering thermostat setpoints to reduce energy consumption of heating system shall not cause energy to be expended to reach the reduced setting.

**N1105.4.4.1 Heat pump controls.** All heat pump system thermostats shall be capable of manual setback and limiting the use of supplemental heat during warm-up periods.

**N1105.4.4.1.1 Outdoor thermostat required.** An outdoor thermostat or factory installed temperature sensor with electronic controls shall be used to lock out supplemental heat based on outdoor air temperature. The lock-out temperature shall be set at 4°F (40°C). There shall be no compressor lock-out temperature.

**N1105.5 Outside combustion air.** See Section R1006 for required outside combustion air for masonry fireplaces, factory-built fireplace and factory-built stoves.

## Ventilation and furnace fac efficiency.

**N1105.6 Ventilation fan efficiency.** Bathroom exhaust fans and outdoor ventilation air supply fans shall be Energy Star certified.

**N1105.7 Furnace fan efficiency.** New central furnaces shall have electronically commutated fan motors with a fan efficiency rating meeting 10 CFR 430.32(y).



## Pipe insulation.

### SECTION N1106 PIPING INSULATION

**N1106.1 Mechanical system piping insulation.** Mechanical system piping capable of carrying fluids above 105°F (40.5°C) or below 55°F (13°C) shall be insulated to a minimum of R-3.

**N1106.2 Domestic and service hot water systems.** Domestic hot water piping shall be insulated to a minimum of R-3 at the following locations:

1. Pipe located outside the building thermal envelope.
2. The first 8 feet (2438 mm) of pipe into and out of a water heater.
3. Recirculating water piping.

## Lighting efficiency.

### SECTION N1107 LIGHTING

**N1107.1 General.** The provisions of this section apply to lighting equipment, related controls and electric circuits serving all conditioned and unconditioned interior floor space and exterior building facades of all dwelling units and guest rooms within residential buildings and structures, or portions thereof.

**N1107.2 High-efficiency interior lighting.** All permanently installed lighting fixtures shall be high efficiency light sources.

The building official shall be notified in writing at the final inspection that the permanently installed lighting fixtures have met this requirement.

**Exception:** Two permanently installed lighting fixtures are not required to be high-efficiency light sources when controlled by a dimmer or automatic control.

**N1107.3 High-efficiency exterior lighting.** All exterior lighting fixtures affixed to the exterior of the building shall be high-efficiency light sources.

**Exception:** Two permanently installed lighting fixtures are not required to be high-efficiency light sources when controlled by automatic control.

## Solar ready provisions.

**N1107.4 Solar interconnection pathway.** A square metal junction box not less than 4 inches by 4 inches (102 mm by 102 mm) with a metal box cover shall be provided within 24 inches (610 mm) horizontally or vertically of the main electrical panel. A minimum ¾-inch (19 mm) nonflexible metal raceway shall extend from the junction box to a capped roof termination or to an accessible location in the attic with a vertical clearance of not less than 36 inches (914 mm).

Where the raceway terminates in the attic, the termination shall be located not less than 6 inches (152 mm) above the insulation. The end of the raceway shall be marked as "RESERVED FOR SOLAR."

**Exception:** In lieu of ¾-inch (19 mm) nonflexible metal raceway, a minimum No. 10 copper 3-wire MC cable installed from the junction box to the termination point including 6 inches (152 mm) additional wire is permitted.

## Plumbing fixture efficiency.

### SECTION N1108 PLUMBING FIXTURE EFFICIENCY

**N1108.1 General.** This section shall apply to plumbing fixture efficiency.

**N1108.1.1 Fixture efficiency.** Fixture efficiency shall be per the Plumbing Code.

## PART II—ALTERNATIVE SYSTEMS ANALYSIS

### SECTION NA1109 ALTERNATIVE SYSTEMS ANALYSIS

*This section provides an alternative method of demonstrating code compliance with this chapter by demonstrating that such deviation will result in an annual energy consumption equal to or less than a building that is in compliance with this chapter.*

**NA1109.1 Annual energy consumption.** The baseline design, conforming to requirements specified in this Chapter and the proposed design shall be analyzed using the same procedures. The analyses shall use equal floor area and equal environmental requirements. The comparison shall be expressed in Btu input per gross building square foot of conditioned space per year (MJ/m<sup>2</sup> per year). The annual energy use of the proposed building shall be 8 percent less than the code baseline prescriptive requirements without the application of additional measures in accordance with Table N1101.1(2).

**NA1109.2 Basis for comparison.** Both baseline and proposed alternative designs shall include parameters as specified in Table NA1109.2.

**NA1109.2.1 Internal heat gain.** The total internal heat gain shall be calculated by Equation NA1109.2.1(1). For single-zone calculations, the daily total sensible internal gains (Btu/day) shall be determined by Equation NA1109.2.1(2). For multiple-zone HVAC systems, the daily total sensible internal gains (Btu/day) shall be determined by Equation NA1109.2.1(2) for the living zone and Equation NA1109.2.1(3) for the sleeping zone. The daily total latent load for each zone shall be determined using Equation NA1109.2.1(4).

Internal heat gains shall be distributed over the day according to the profile in Table NA1109.2.

Where multiple-zone space conditioning is modeled, the profile shown for Zone 2 shall be used for bedrooms and bathrooms; the profile shown for Zone 1 shall be used for all other conditioned rooms. Where single-zone space conditioning is modeled, the hourly profile for single-zone designs shall be used.

**Equation NA1109.2.1(1)**

Total Heat Gains = Sensible Heat Gains + Latent Heat Gains

**Equation NA1109.2.1(2)**

Single-Zone or Living Zone: Sensible Heat Gains = (Floor Area of Zone 15 Btu/day ft<sup>2</sup>) + (Number of living units 20,000 Btu/day)

**Equation NA1109.2.1(3)**

Sleeping Zone: Sensible Heat Gains = Floor Area of Zone 15 Btu/day ft<sup>2</sup>

**Equation NA1109.2.1(4)**

Latent Heat Gains = 0.2 Sensible Heat Gains

**NA1109.2.2 Thermostat setpoints.** In the analysis for both the baseline and proposed designs, all conditioned spaces shall be maintained at the specified thermostat setpoints at all times except for minor deviations at thermostat setback and setup and when outdoor conditions exceed normal design conditions.

If the specified equipment in the proposed design is too small to meet the load, its capacity shall be increased in the calculations. If equipment to meet a load is not included in the design, such equipment shall be assumed in the calculations and its energy use included. In no case shall the energy use of proposed design be reduced by not conditioning its spaces.

For central space conditioning systems without zonal control, the entire conditioned floor area shall be on thermostatically controlled zone. The thermostat settings shall be those listed for a single-zone in Table NA1109.2.2. For multiple-zone designs, the multiple-zone thermostat settings in Table NA1109.2.2 shall be used. Zone 1 represents all conditioned spaces other than Zone 2 (bedrooms and bathrooms). The effect of heat transfer between zones, including nonclosable openings shall be included in the calculation

**TABLE NA1109.2  
BASIS FOR COMPARISON**

INPUT PARAMETERS FOR ANALYSIS		
Parameter	Proposed Building	Code Baseline
<b>Building Thermal Envelope</b>		
Opaque construction materials	As designed	Code minimum
Fenestration performance	As designed	Code minimum
Shading devices	As designed	Same as proposed
Window area	As designed	Same as proposed
Skylight area	As designed	Same as proposed <sup>a</sup>
Building orientation	As designed	Same as proposed
Solar gain	As designed	Same as proposed
Building infiltration	0.3 ACH Natural	Same as proposed
<b>HVAC Systems</b>		
HVAC system type(s)	As designed	Same as proposed
HVAC efficiency	Code efficiencies <sup>b</sup>	Same as proposed <sup>b</sup>
Heating fuel	As designed	Same as proposed
Cooling fuel	As designed	Same as proposed
Temperature setpoints	As designed	Same as proposed
Equipment capacity	As designed	Same as proposed
Mechanical ventilation	As designed	Same as proposed
<b>Lighting</b>		
Artificial lighting	As designed	Code required
Daylighting	As designed	Same as proposed
<b>Design Conditions</b>		
Building occupancy	As designed	Same as proposed
Building operational schedules	As designed	Same as proposed
Climatic data	As designed	Same as proposed
Internal loads	As designed	Same as proposed
Cooking fuel	As designed	Same as proposed

<sup>a</sup>. Code baseline skylight area shall be same as proposed up to a maximum of two percent of the heated space floor area.

<sup>b</sup>. Systems not regulated by code, such as electric heat, shall comply with standard equipment efficiency for such equipment.

**NA1109.3 Analysis procedure.** The analysis of the annual energy usage of the standard and the proposed alternative building and system designs shall meet the following criteria:

**TABLE NA1109.2.2  
THERMOSTAT SETTINGS (°F)**

TIME OF DAY	SINGLE ZONE		MULTIPLE ZONE			
	Heat	Cool	Zone 1 Living		Zone 2 Sleeping	
			Heat	Cool	Heat	Cool
6 – 9 a.m.	68	78	68	78	68	78
9 a.m. – 5 p.m.	68	78	68	78	60	85
5 – 11 p.m.	68	78	68	78	68	78
11 p.m. – 6 a.m.	60	78	60	85	60	78

**NA1109.3.1** The building heating/cooling load calculation procedure used for annual energy consumption analysis shall be of sufficient detail to permit the evaluation of effect of building data (such as orientation, size and shape, and transfer characteristics of mass, air, moisture and heat) and hourly climatic data.

**NA1109.3.2** The calculation procedure used to simulate the operation of the building and its service systems through a full-year operating period shall be of sufficient detail to permit the evaluation of the effect of system design, climatic factors, operational characteristics and mechanical equipment on annual energy usage. Manufacturer’s data or comparable field test data shall be used when available in the simulation of all systems and equipment. The calculation procedure shall be based on 8,760 hours of operation of the building and its service systems and shall utilize techniques recommended in the appropriate ASHRAE publications or produce results consistent with such recommended procedures.

**NA1109.3.2.1** The calculation procedure shall explicitly cover the following items:

1. Climatic data: coincident hourly data for temperatures, solar radiation, wind and humidity of typical days in the year representing seasonal variation.
2. Building data: orientation, size, shape, mass, air, moisture and heat transfer characteristics.
3. Operational characteristics: temperature, humidity, ventilation, illumination, control mode for occupied and nonoccupied hours.
4. Mechanical equipment: design capacity, part load profile.
5. Internal heat generation: lighting, equipment, number of people during occupied and nonoccupied periods.

**NA1109.4 Documentation.** Proposed alternative designs, submitted as requests for exceptions to the standard design criteria, shall be accompanied by an energy analysis comparison report prepared by a registered engineer. The report shall provide sufficient technical detail describing the differences between the two building and systems designs and on the data used in and resulting from the comparative analysis.

**NA1109.4.1** The documentation shall demonstrate that the analysis used is consistent with the techniques and procedures specified in this section and the following ASHRAE documents:

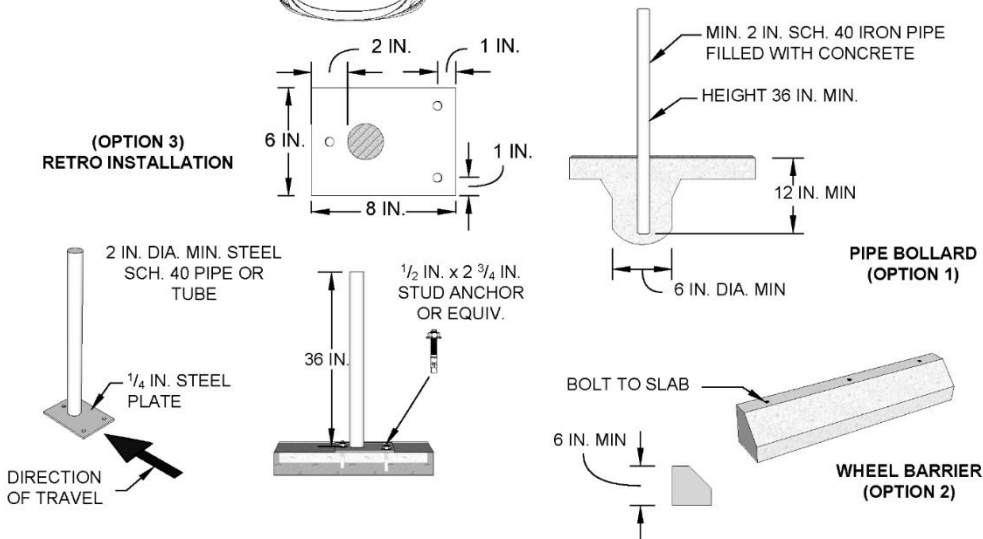
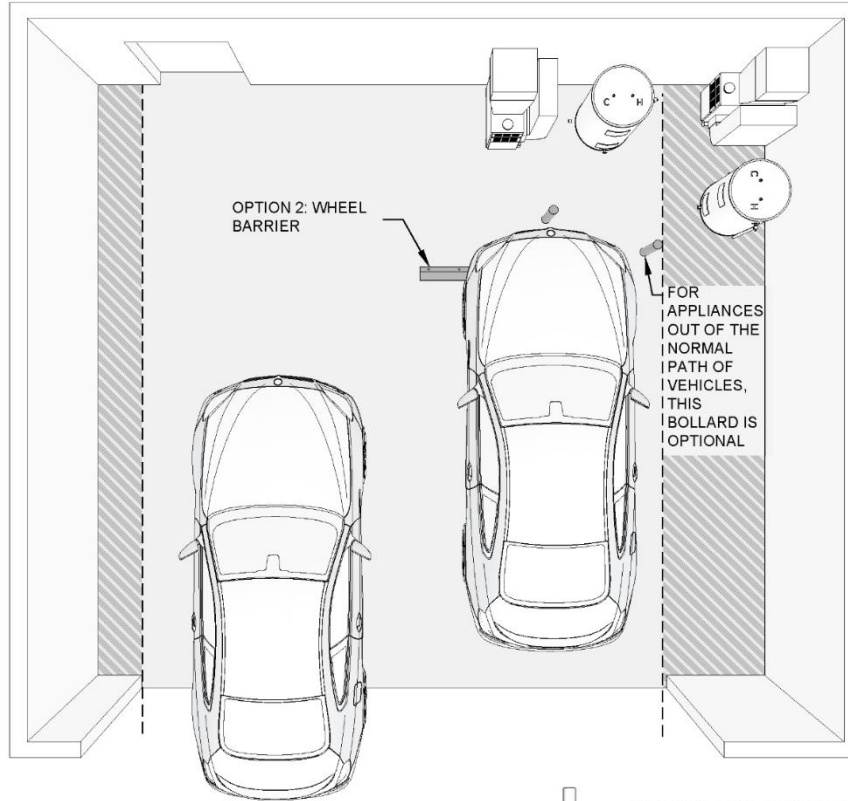
1. 2001 ASHRAE *Handbook of Fundamentals*.
2. 2000 ASHRAE *Handbook of HVAC Systems and Equipment*.
3. ASHRAE *Principles of Heating, Ventilating and Air Conditioning*.



# CHAPTER 13 GENERAL MECHANICAL SYSTEM REQUIREMENTS

## Impact protection.

BARRIER LOCATIONS WHEN APPLIANCES ARE IN THE NORMAL PATH OF VEHICLES



**FIGURE M1307.3.1**  
**TYPICAL MOTOR VEHICLE IMPACT PROTECTION**

## CHAPTER 14 HEATING AND COOLING EQUIPMENT AND APPLIANCES

### Condensate drain pipe.

**M1411.3.2 Drain pipe materials and sizes.** Components of the condensate disposal system shall be ABS, cast iron, copper, cross-linked polyethylene, CPVC, galvanized steel, PE-RT, polyethylene, polypropylene or PVC pipe or tubing. Components shall be selected for the pressure and temperature rating of the installation. Material for gravity drains shall be smooth and rigid to maintain the slope to the discharge point. Condensate waste and drain line size shall be not less than  $\frac{3}{4}$ -inch (19 mm) nominal diameter from the drain pan connection to the place of condensate disposal. Where the drain pipes from more than one unit are manifolded together for condensate drainage, the pipe or tubing shall be sized in accordance with an *approved* method.

### Insulation of refrigerant piping.

**M1411.6 Insulation of refrigerant piping.** Piping and fittings for refrigerant vapor (suction) lines shall be insulated with insulation having a thermal resistivity of not less than R-4 and having external surface permeance not exceeding 0.05 perm [2.87 ng/(s · m<sup>2</sup> · Pa)] when tested in accordance with ASTM E96.

# CHAPTER 15 EXHAUST SYSTEMS

## Dryer duct termination.

**M1502.3 Duct termination.** Exhaust ducts shall terminate on the outside of the building. Exhaust duct terminations shall be made with a full opening exhaust outlet or in accordance with the dryer manufacturer's installation instructions. If the manufacturer's instructions do not specify a termination location, the exhaust duct shall terminate not less than 3 feet (914 mm) in any direction from openings into buildings. Exhaust duct terminations shall be equipped with a backdraft damper. Screens shall not be installed at the duct termination.

### **M1502.3.1 Exhaust termination outlet and passageway size.**

The passageway of dryer exhaust duct terminals shall be undiminished in size and shall provide an open area of not less than 12.5 square inches (8065 mm<sup>2</sup>).

## Dryer duct installation.

**M1502.4 Dryer exhaust ducts.** Dryer exhaust ducts shall conform to the requirements of Sections M1502.4.1 through M1502.4.7.

**M1502.4.1 Material and size.** Exhaust ducts shall have a smooth interior finish and shall be constructed of metal not less than 0.0157 inch (0.3950 mm) in thickness (No. 28 gage). The duct shall be 4 inches (102 mm) nominal in diameter.

**M1502.4.2 Duct installation.** Exhaust ducts shall be supported at intervals not to exceed 4 feet (1219 mm) and shall be secured in place. The insert end of the duct shall extend into the adjoining duct or fitting in the direction of airflow. Exhaust duct joints shall be sealed with listed tape. Ducts shall not be joined with screws or similar fasteners that protrude into the inside of the duct. Where dryer exhaust ducts are enclosed in wall or ceiling cavities, such cavities shall allow the installation of the duct without deformation.

## Dryer exhaust ducts.

**M1502.4.2 Duct installation.** Exhaust ducts shall be supported at intervals not to exceed 4 feet (1219 mm) and shall be secured in place. The insert end of the duct shall extend into the adjoining duct or fitting in the direction of airflow. Exhaust duct joints shall be sealed with listed tape. Ducts shall not be joined with screws or similar fasteners that protrude into the inside of the duct. Where dryer exhaust ducts are enclosed in wall or ceiling cavities, such cavities shall allow the installation of the duct without deformation.

## Domestic cooking exhaust equipment.

**M1503.1 General.** Domestic cooking equipment shall be provided with exhaust equipment.

**M1503.2 Domestic cooking exhaust.** Domestic cooking exhaust equipment shall comply with one of the following:

1. The fan for overhead range hoods and downdraft exhaust equipment not integral with the cooking appliance shall be listed and labeled in accordance with UL 507.
2. Overhead range hoods and downdraft exhaust equipment with integral fans shall comply with UL 507.
3. Domestic cooking appliances with integral downdraft exhaust equipment shall be listed and labeled in accordance with ANSI Z21.1 or UL 858.
4. Microwave ovens with integral exhaust for installation over the cooking surface shall be listed and labeled in accordance with UL 923.

**M1503.3 Exhaust discharge.** Domestic cooking exhaust equipment shall discharge to the outdoors through a duct. The duct shall have a smooth interior surface, shall be airtight, shall be equipped with a backdraft damper and shall be independent of all other exhaust systems. Ducts serving domestic cooking exhaust equipment shall not terminate in an attic or crawl space or areas inside the building.

**Exception:** Where installed in accordance with the manufacturer's instructions listed and labeled ductless range hoods shall not be required to discharge to the outdoors where all the following conditions are met:

1. Where continuous mechanical exhaust of not less than 20 cubic feet per minute (0.0094 m<sup>3</sup>/s) is provided in the space.
2. Natural ventilation is provided in accordance with Section R303.1, without exception, for the kitchen.

## Makeup air.

**M1503.6.2 Makeup air dampers.** Where makeup air is required by Section M1503.6, makeup air dampers shall comply with this section. Each damper shall be a gravity damper or an electrically operated damper that automatically opens when the exhaust system operates. Dampers shall be located to allow access for inspection, service, repair and replacement without removing permanent construction or any other ducts not connected to the damper being inspected, serviced, repaired or replaced. Gravity or barometric dampers shall not be used in passive makeup air systems except where the dampers are rated to provide the design makeup airflow at a pressure differential of 0.01 in. w.c. (3 Pa) or less.

## Mechanical ventilation.

**M1505.1 General.** Where Section R303.3 requires toilet rooms, bathrooms, and rooms with bathing or spa facilities to be mechanically ventilated, the ventilation equipment shall be installed in accordance with this section. Where local exhaust or whole-house mechanical ventilation is provided, the equipment shall be designed in accordance with this section and the applicable provisions of Chapter 11.

**M1505.2 Recirculation of air.** Exhaust air from range hoods, bathrooms, toilet rooms and rooms with bathing or spa facilities shall not be recirculated within a residence or **circulated** to another *dwelling unit* and shall be exhausted directly to the outdoors. Exhaust air from bathrooms, toilet rooms **and kitchens** shall not discharge into an *attic*, crawl space or other areas inside the building. **This section shall not prohibit the installation of ductless range hoods in accordance with the exception to Section M1503.3.**

**M1505.3 Exhaust equipment.** Exhaust equipment serving single *dwelling units* shall be *listed and labeled* as providing the minimum required airflow in accordance with ANSI/ AMCA 210-ANSI/ASHRAE 51.

**M1505.4 Whole-house mechanical ventilation system.** *Whole-house mechanical ventilation systems* shall be designed in accordance with Sections M1505.4.1 through M1505.4.4.

**M1505.4.1 System design.** The *whole-house mechanical ventilation system* shall *provide balanced ventilation*. Local exhaust or supply fans are permitted to serve as part of such a system. Outdoor air ventilation provided by a supply fan ducted to the return side of an air handler shall be considered as providing supply ventilation for the balanced system.

**M1505.4.2 System controls.** The *whole-house mechanical ventilation system* shall be provided with controls that enable manual override.

**M1505.4.3 Mechanical ventilation rate.** The whole-house mechanical ventilation system shall provide outdoor air at a continuous rate as determined in accordance with Table M1505.4.3(1) or Equation 15-1.

Ventilation rate in cubic feet per minute =  $(0.01 \times \text{total square foot area of house}) + [7.5 \times (\text{number of bedrooms} + 1)]$

### Equation 15-1

**Exception:** The *whole-house mechanical ventilation system* is permitted to operate intermittently where the system has controls that enable operation for not less than 25 percent of each 4-hour segment and the ventilation rate prescribed in Table M1505.4.3(1) is multiplied by the factor determined in accordance with Table M1505.4.3(2).

## Exhaust ventilation rate

**M1505.5 Exhaust ventilation rate.** Ventilation systems shall be designed to have the capacity to exhaust the minimum air flow rate determined in accordance with Table M1505.5. Exhaust flow ratings shall be source specific ventilation systems shall be in accordance with the Home Ventilating Institute (HVI) or Air Movement and Control Association (AMCA) residential ventilation standards. Fans shall be Energy Star certified in accordance with Section N1105.5.

### M1505.5.1 Sound ratings for fans in rooms with bathing or spa facilities.

**M1505.5.1.1 Continuous ventilation fans.** Continuous ventilation fans shall be rated for sound at a maximum of 1.0 sone.

**M1505.5.1.2 Intermittent fans.** Intermittent fans shall be rated for sound at a maximum of 3 sones, unless the maximum rated airflow exceeds 400 cubic feet per minute (200 L/s).

**M1505.5.1.3 Remote fans.** Remotely installed fans that are at least 4 feet (1220 mm) away from the inlet grill are exempt from the sone rating requirements of Sections M1505.5.1.1 and M1505.5.1.2.

TABLE M1505.5  
EXHAUST RATES FOR RESIDENTIAL DWELLINGS

DOMESTIC KITCHENS	
Range hoods/downdraft exhaust.	Min. 150 cfm intermittent
BATHROOMS/TOILET ROOMS	
Rooms containing bathing and spa facilities. (Static pressure shall be rated @ 0.10-inch water gauge for intermittent fans.)	Min. 80 cfm intermittent or 20 cfm continuous
Toilet rooms without bathing or spa facilities, when not provided with natural ventilation in accordance with Section R303.3.2.	Min. 50 cfm

For SI: 1 cubic foot per minute = 0.0004719 m<sup>3</sup>/s.

## Mechanical ventilation for rooms with water closets, bathing facilities or spa facilities.

**M1505.6 Rooms with water closets, bathing facilities or spa facilities.** Rooms containing water closets, bathing facilities or spa facilities shall be provided with a mechanical ventilation system controlled by a dehumidistat, timer or similar means of automatic control.

# CHAPTER 16 DUCT SYSTEMS

## Duct construction.

**M1601.1.1 Above-ground duct systems.** Above-ground *duct systems* shall conform to the following:

1. *Equipment* connected to *duct systems* shall be designed to limit discharge air temperature to not greater than 250°F (121°C).
2. Factory-made ducts shall be listed and labeled in accordance with UL 181 and installed in accordance with the manufacturer's instructions.
3. Fibrous glass duct construction shall conform to the SMACNA *Fibrous Glass Duct Construction Standards* or NAIMA *Fibrous Glass Duct Construction Standards*.
4. Field-fabricated and shop-fabricated metal and flexible duct constructions shall conform to the SMACNA *HVAC Duct Construction Standards—Metal and Flexible* except as allowed by Table M1601.1.1. Galvanized steel shall conform to ASTM A653.
5. *Duct systems* shall be constructed of materials having a flame spread index of not greater than 200.
6. Stud wall cavities to be used as transfer air plenums shall comply with the following conditions:
  - 6.1. These cavities or spaces shall not be used as a plenum for supply air.
  - 6.2. These cavities or spaces shall not be part of a required fire-resistance-rated assembly.
  - 6.3. Stud wall cavities shall not convey air from more than one floor level.
  - 6.4. Stud wall cavities and joist-space plenums shall be isolated from adjacent concealed spaces by tight-fitting fireblocking in accordance with Section R602.8.
  - 6.5. Stud wall cavities in the outside walls of building envelope assemblies shall not be utilized as air plenums.
7. **Volume dampers, equipment and other means of supply, return and exhaust air adjustment used in system balancing shall be provided with access.**

**M1601.1.1.1 Use of building cavities in new construction.** Except as allowed by Section M1601.1.1, the use of building cavities for air ducts, or plenums is not allowed in new construction or in an *addition* to an existing structure.

**M1601.1.1.2 Use of building cavities in existing buildings.** The use of building cavities for air ducts or plenums is allowed in the *alteration* or remodel of an existing structure. Gypsum products are permitted to be used to construct air ducts or plenums provided that the air temperature does not exceed 125°F (52°C) and exposed surfaces are not subject to condensation.

Stud wall cavities and the spaces between solid floor joists to be utilized as air ducts or plenums shall comply with the following conditions:

1. Such cavities or spaces shall not be utilized as a duct or plenum for supply air.
2. Such cavities or spaces shall not be part of a required fire-resistance-rated assembly.
3. Stud wall cavities shall not convey air from more than one floor level.
4. Stud wall cavities and joist space ducts or plenums shall comply with floor penetration protection requirements of this code.
5. Stud wall cavities and joist space ducts or plenums shall be isolated from adjacent concealed spaces by tight-fitting fire blocking in accordance with Section R302.11, and sealed to prevent conveyance of air from other spaces.

**M1601.1.2 Underground duct systems.** Underground *duct systems* shall be constructed of *approved* concrete, clay, metal or plastic. The maximum design temperature for **systems utilizing** plastic duct and fittings shall be 150°F (66°C). Metal ducts shall be protected from corrosion in an *approved* manner or shall be completely encased in concrete not less than 2 inches (51 mm) thick. Nonmetallic ducts shall be installed in accordance with the manufacturer's instructions. Plastic pipe and fitting materials shall conform to cell classification 12454-B of ASTM D1248 or ASTM D1784 and external loading properties of ASTM D2412. **Ducts shall slope to a drainage point that has access. Ducts shall be sealed, secured and tested prior to encasing the ducts in concrete or direct burial.** Metallic ducts having an *approved* protective coating and nonmetallic ducts shall be installed in accordance with the manufacturer's instructions.

## Joints, seams and connections.

**M1601.4.1 Joints, seams and connections.** Longitudinal and transverse joints, seams and connections in metallic and nonmetallic ducts shall be constructed as specified in SMACNA *HVAC Duct Construction Standards—Metal and Flexible* and NAIMA *Fibrous Glass Duct Construction Standards*. Joints, longitudinal and transverse seams, and connections in ductwork shall be securely fastened and sealed with welds, gaskets, mastics (adhesives), mastic-plus-embedded-fabric systems, liquid sealants or tapes. Tape shall not be used to seal metal ductwork or be used as the only sealing method between metal duct and flexible or fibrous duct. Tape is permitted to be used with metal duct at connections to equipment requiring future replacement. Tapes and mastics used to seal fibrous glass ductwork shall be *listed* and *labeled* in accordance with UL 181A and shall be marked "181A-P" for pressure-sensitive tape, "181 A-M" for mastic or "181 A-H" for heat-sensitive tape.

Tapes and mastics used to seal metallic and flexible air ducts and flexible air connectors shall comply with UL 181B and shall be marked "181 B-FX" for pressure-sensitive tape or "181 BM" for mastic. Duct connections to flanges of air distribution system equipment shall be sealed and mechanically fastened.

Mechanical fasteners for use with flexible nonmetallic air ducts shall comply with UL 181B and shall be marked 181B-C. Crimp joints for round metallic ducts shall have a contact lap of not less than 1 inch (25 mm) and shall be mechanically fastened by means of not less than three sheet-metal screws or rivets equally spaced around the joint.

Closure systems used to seal all ductwork shall be installed in accordance with the manufacturers' instructions.

**Exceptions:**

1. Spray polyurethane foam shall be permitted to be applied without additional joint seals.
2. Where a duct connection is made that is partially **without access**, three screws or rivets shall be equally spaced on the exposed portion of the joint so as to prevent a hinge effect.
3. For ducts having a static pressure classification of less than 2 inches of water column (500 Pa), additional closure systems shall not be required for continuously welded joints and seams and locking-type joints and seams. **This exception shall not apply to snap-lock and button-lock type joints and seams that are located outside of conditioned spaces.**

## **Ductwork installation.**

**M1601.4.11 Ductwork installation location.** All supply and return ductwork shall be installed within the building thermal envelope in accordance with Section N1105.3.



# CHAPTER 20 BOILERS AND WATER HEATERS

## Pool heaters.

### SECTION M2006 POOL HEATERS

**M2006.1 General.** Pool and spa heaters shall be installed in accordance with the manufacturer's installation instructions. Oil-fired pool heaters shall comply with UL 726. Electric pool and spa heaters shall comply with UL 1261. **Pool and spa heat pump water heaters shall comply with UL 1995 or CSA C22.2 No. 236.**

**Exception:** Portable residential spas and portable residential exercise spas.

## CHAPTER 23 SOLAR THERMAL ENERGY SYSTEMS

### Access.

**M2301.1 General.** This section provides for the design, construction, installation, *alteration* and repair of *equipment* and systems using solar nonpotable space heating or cooling, hot water heating and swimming pool heating.

**M2301.2 Installation.** The installation of solar thermal energy systems shall comply with Sections M2301.2.1 through M2301.2.13.

**M2301.2.1 Access.** Access shall be provided to solar energy *equipment* for maintenance. Solar systems and appurtenances shall not obstruct or interfere with the operation of any doors, windows or other building components requiring operation or access. Roof-mounted solar thermal equipment shall not obstruct or interfere with the operation of roof-mounted equipment, appliances, chimneys, plumbing vents, roof hatches, smoke vents, skylights and other roof penetrations and openings.

### Freezing protection.

**M2301.2.6 Protection from freezing.** System components shall be protected from damage resulting from freezing of heat-transfer liquids at the winter design temperature provided in Table R301.2(1). Freeze protection shall be provided in accordance with ICC 900/SRCC 300. Drain-back systems shall be installed in compliance with Section M2301.2.6.1. Systems utilizing freeze-protection valves shall comply with Section M2301.2.6.2.

**M2301.2.6.1 Drain-back systems.** Drain-back systems shall be designed and installed to allow for manual gravity draining of fluids from areas subject to freezing to locations not subject to freezing, and air filling of the components and piping. Such piping and components shall maintain a horizontal slope in the direction of flow of not less than one-fourth unit vertical in 12 units horizontal (2-percent slope). Piping and components subject to manual gravity draining shall permit subsequent air filling upon drainage and air venting upon refilling.

**M2301.2.6.2 Freeze-protection valves.** Freeze-protection valves shall discharge in a manner that does not create a hazard or structural damage.

## CHAPTER 24 FUEL GAS

### Prohibited appliance locations

**G2406.2 Prohibited locations.** *Appliances* shall not be located in sleeping rooms, bathrooms, toilet rooms, storage closets or surgical rooms, or in a space that opens only into such rooms or spaces, except where the installation complies with one of the following:

1. The *appliance* is a direct-vent *appliance* installed in accordance with the conditions of the listing and the manufacturer's instructions.
2. *Vented room heaters*, wall *furnaces*, vented decorative *appliances*, vented gas *fireplaces*, vented gas *fireplace heaters* and decorative *appliances* for installation in vented solid fuel-burning *fireplaces* are installed in rooms that meet the required volume criteria of Section G2407.5.
3. A single wall-mounted *unvented room heater* is installed in a bathroom and such *unvented room heater* is equipped as specified in Section G2445.6 and has an input rating not greater than 6,000 *Btu/h* (1.76 kW). The bathroom shall meet the required volume criteria of Section G2407.5.
4. A single wall-mounted *unvented room heater* is installed in a bedroom and such *unvented room heater* is equipped as specified in Section G2445.6 and has an input rating not greater than 10,000 *Btu/h* (2.93 kW). The bedroom shall meet the required volume criteria of Section G2407.5.
5. The *appliance* is installed in a room or space that opens only into a bedroom or bathroom, and such room or space is used for no other purpose and is provided with a solid weather-stripped door equipped with an *approved* self-closing device. *Combustion air* shall be taken directly from the outdoors in accordance with Section G2407.6.
6. A clothes dryer is installed in a residential bathroom or toilet room having a permanent opening with an area of not less than 100 square inches (0.06 m<sup>2</sup>) that communicates with a space outside of a sleeping room, bathroom, toilet room or storage closet.

### Metallic pipe

**G2414.4.2 Steel.** *Steel*, *stainless Steel* and wrought-iron *pipe* shall not be lighter than Schedule 10 and shall comply with the dimensional standards of ASME B36.10, 10M and one of the following standards:

1. ASTM A53/A53M.
2. ASTM A106.
3. ASTM A312.

**G2414.5 Metallic tubing.** *Tubing* shall not be used with gases corrosive to the tubing material.

**G2414.5.1 Steel tubing.** *Steel tubing* shall comply with ASTM A254.

**G2414.5.2 Stainless steel.** *Stainless steel tubing* shall comply with ASTM A268 or ASTM A269.

### Appliance shutoff valve

**G2420.5.1 Located within same room.** The shutoff valve shall be located in the same room as the *appliance*. The shutoff valve shall be within 6 feet (1829 mm) of the *appliance*, and shall be installed upstream of the union, connector or quick disconnect device it serves. Such shutoff *valves* shall be provided with *access*. *Shutoff valves serving movable appliances, such as cooking appliances and clothes dryers, shall be considered to be provided with access where installed behind such appliances.* *Appliance shutoff valves* located in the firebox of a *fireplace* shall be installed in accordance with the *appliance manufacturer's instructions*.

### Tubing systems

**G2420.6 Shutoff valves in tubing systems.** Shutoff valves installed in tubing systems shall be rigidly and securely supported independently of the tubing.

### Cooking appliance prohibited locations

**G2447.2 Prohibited location.** Cooking appliances designed, tested, listed and labeled for use in commercial occupancies shall not be installed within dwelling units or within any area where domestic cooking operations occur.

#### Exceptions:

1. Appliances that are also listed as domestic cooking appliances.
2. Where the installation is designed by a licensed Professional Engineer, in compliance with the manufacturer's installation instructions.

### Metallic piping joints and fittings

**G2414.10.1 Pipe joints.** Schedule 40 and heavier *Pipe* joints shall be threaded, flanged, brazed, welded or assembled with press-connect fittings listed in accordance with ANSI LC4/CSA 6.32. *Pipe* lighter than Schedule 40 shall be connected using press-connect fittings, flanges, brazing or welding. Where nonferrous *pipe* is brazed, the *brazing* materials shall have a melting point in excess of 1,000°F (538°C). *Brazing* alloys shall not contain more than 0.05-percent phosphorus.

**G2414.10.2 Copper Tubing joints.** *Copper Tubing* joints shall be assembled with *approved gas tubing* fittings, shall be brazed with a material having a melting point in excess of 1,000°F (538°C) or assembled with press-connect fittings listed in accordance with ANSI LC4/CSA 6.32. *Brazing alloys* shall not contain more than 0.05-percent phosphorus.

**G2414.10.3 Stainless steel tubing joints.** *Stainless steel tubing* joints shall be welded, assembled with approved tubing fittings, brazed with a material having a melting point in excess of 1,000°F (538°C), or assembled with press-connect fittings listed in accordance with ANSI LC4/CSA 6.32.

**G2414.10.4 Flared joints.** *Flared joints* shall be used only in systems constructed from nonferrous *pipe* and *tubing* where experience or tests have demonstrated that the joint is suitable for the conditions and where provisions are made in the design to prevent separation of the joints.

**G2414.10.5 Metallic fittings.** Metallic fittings shall comply with the following:

1. Fittings used with steel, **stainless steel** or wrought-iron *pipe* shall be **steel, stainless** steel, copper alloy, malleable iron or cast iron.
2. Fittings used with copper or copper alloy *pipe* shall be copper or copper alloy.
3. Cast-iron bushings shall be prohibited.
4. Special fittings. Fittings such as couplings, proprietary-type joints, saddle tees, gland-type compression fittings, and flared, flareless and compression-type *tubing* fittings shall be: used within the fitting manufacturer's pressure-temperature recommendations; used within the service conditions anticipated with respect to vibration, fatigue, thermal expansion and contraction; and shall be *approved*.
5. Where pipe fittings are drilled and tapped in the field, the operation shall be in accordance with all of the following:
  - 5.1. The operation shall be performed on systems having operating pressures of 5 psi (34.5 kPa) or less.
  - 5.2. The operation shall be performed by the gas supplier or the gas supplier's designated representative.
  - 5.3. The drilling and tapping operation shall be performed in accordance with written procedures prepared by the gas supplier.
  - 5.4. The fittings shall be located outdoors.
  - 5.5. The tapped fitting assembly shall be inspected and proven to be free of leakage.

# APPENDIX F RADON CONTROL METHODS

## Radon control requirements.

**AF103.1 General.** The following construction techniques are intended to resist radon entry in new residential buildings. These techniques are required in areas where designated by Section AF101.1. See Figures AF103(1), AF103(2) and AF103(3).

## Potential radon entry routes.

**AF103.4.8 Ducts.** Ductwork passing through or beneath a slab shall be of seamless material unless the air-handling system is designed to maintain continuous positive pressure within such ducting. Joints in such ductwork shall be sealed to prevent air leakage.

Ductwork located in crawl spaces shall have seams and joints sealed by closure systems in accordance with Section M1601.4.1.

Where fan systems circulate air to living spaces, all ductwork located in the crawl space shall be positive-pressure ductwork.

**AF103.4.9 Crawl space floors.** Openings around all penetrations through floors above crawl spaces shall be caulked or otherwise filled to prevent air leakage.

**AF103.4.10 Crawl space access.** Access doors and other openings or penetrations between *basements* and adjoining crawl spaces shall be closed, gasketed or otherwise filled to prevent air leakage.

**AF103.5 Crawl space mitigation system.** In buildings with crawl space foundations, a system complying with Section AF103.5.1 shall be installed during construction.

**Exception:** Buildings in which an *approved* mechanical crawl space ventilation system or other equivalent system is installed.

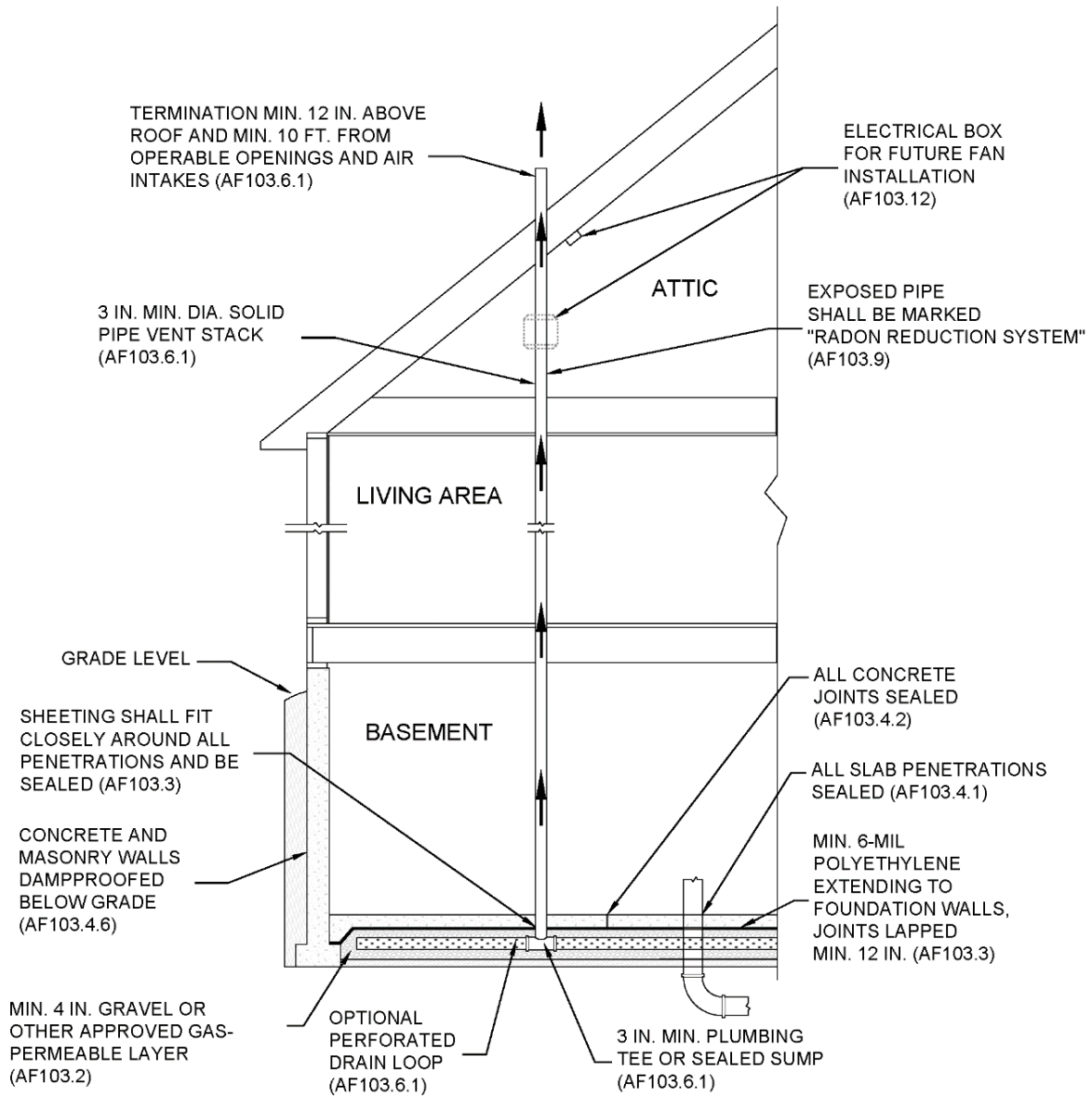
### **AF103.5.1 Passive submembrane depressurization system.**

**AF103.5.1.1 Ventilation.** Crawl spaces shall be provided with vents to the exterior of the building. The minimum net area of ventilation openings shall comply with Section R408.1.

**AF103.5.1.2 Soil-gas-retarder.** The soil in crawl spaces shall be covered with a continuous layer of minimum 6-mil (0.15 mm) polyethylene soil-gas-retarder. The ground cover shall be lapped not less than 12 inches (305 mm) at joints and shall extend to all foundation walls enclosing the crawl space area.

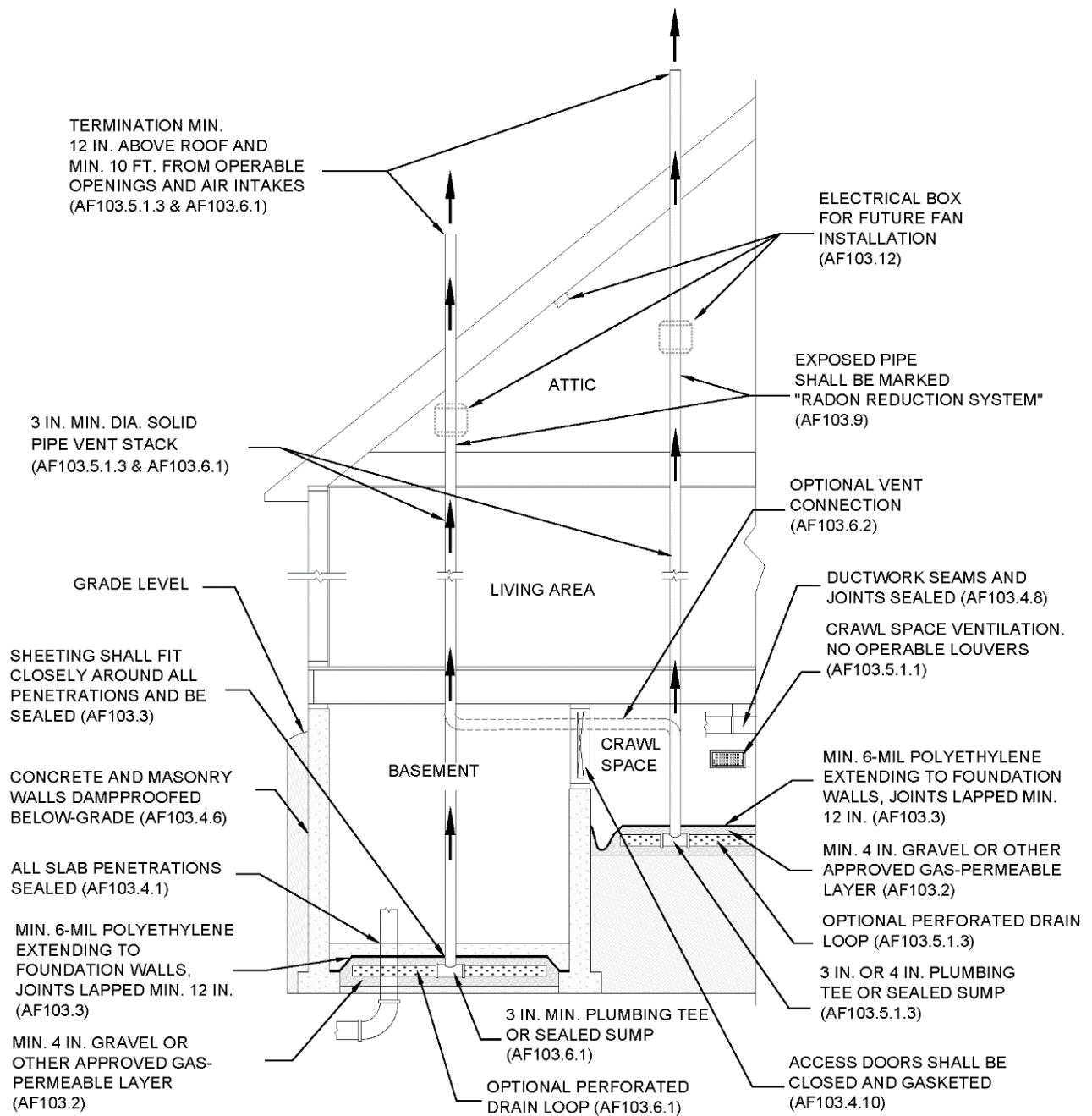
**AF103.5.1.3 Vent pipe.** A plumbing tee or other *approved* connection shall be inserted horizontally beneath the sheeting and connected to a 3or 4-inch-diameter (76 or 102 mm) fitting with a vertical vent pipe installed through the sheeting. The vent pipe shall be extended up through the building floors, and terminate not less than 12 inches (305 mm) above the roof in a location not less than 10 feet (3048 mm) away from any window or other opening into the *conditioned spaces* of the building that is less than 2 feet (610 mm) below the exhaust point, and 10 feet (3048 mm) from any window or other opening in adjoining or adjacent buildings.





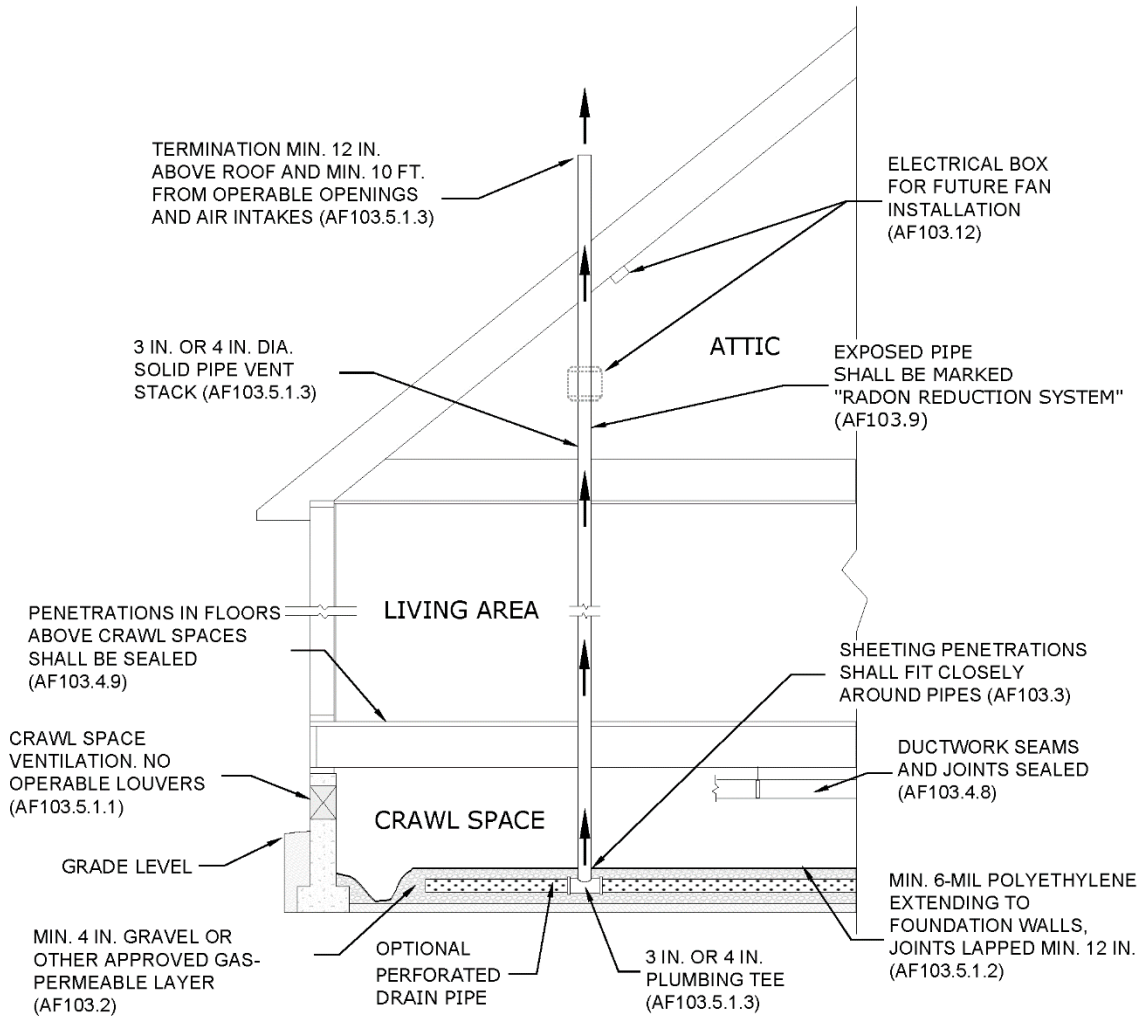
For SI: 1 inch = 25.4 mm.

**FIGURE AF103(1)**  
**RADON-RESISTANT CONSTRUCTION DETAILS FOR BASEMENT FOUNDATIONS**



For SI: 1 inch = 25.4 mm.

**FIGURE AF103(2)**  
**RADON-RESISTANT CONSTRUCTION FOR CRAWL SPACE FOUNDATIONS**



For SI: 1 inch = 25.4 mm.

**FIGURE AF103(3)**  
**RADON-RESISTANT CONSTRUCTION FOR COMBINATION BASEMENT/CRAWL SPACE FOUNDATIONS**