

# SINGULAIR®

INDIVIDUAL HOME  
WASTEWATER TREATMENT PLANT  
with

# BIO-KINETIC® SYSTEM

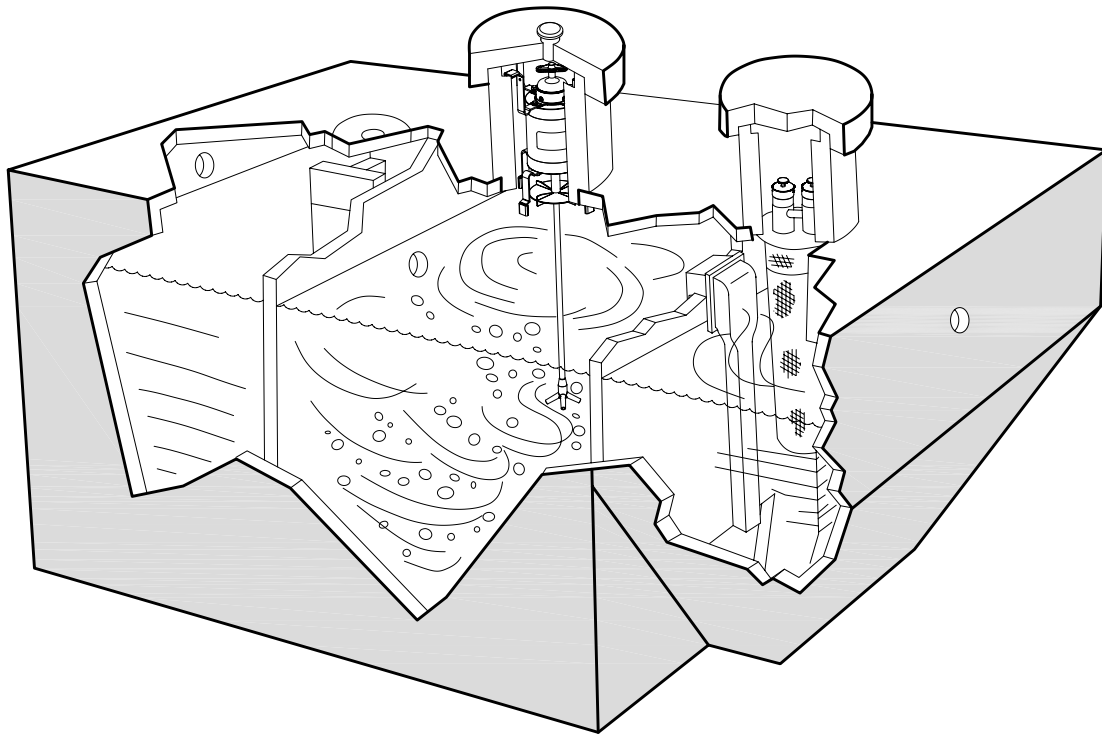

PROGRESS THROUGH *norweco*® SERVICE SINCE 1906

OREGON INSTALLATION MANUAL

# SINGULAIR®

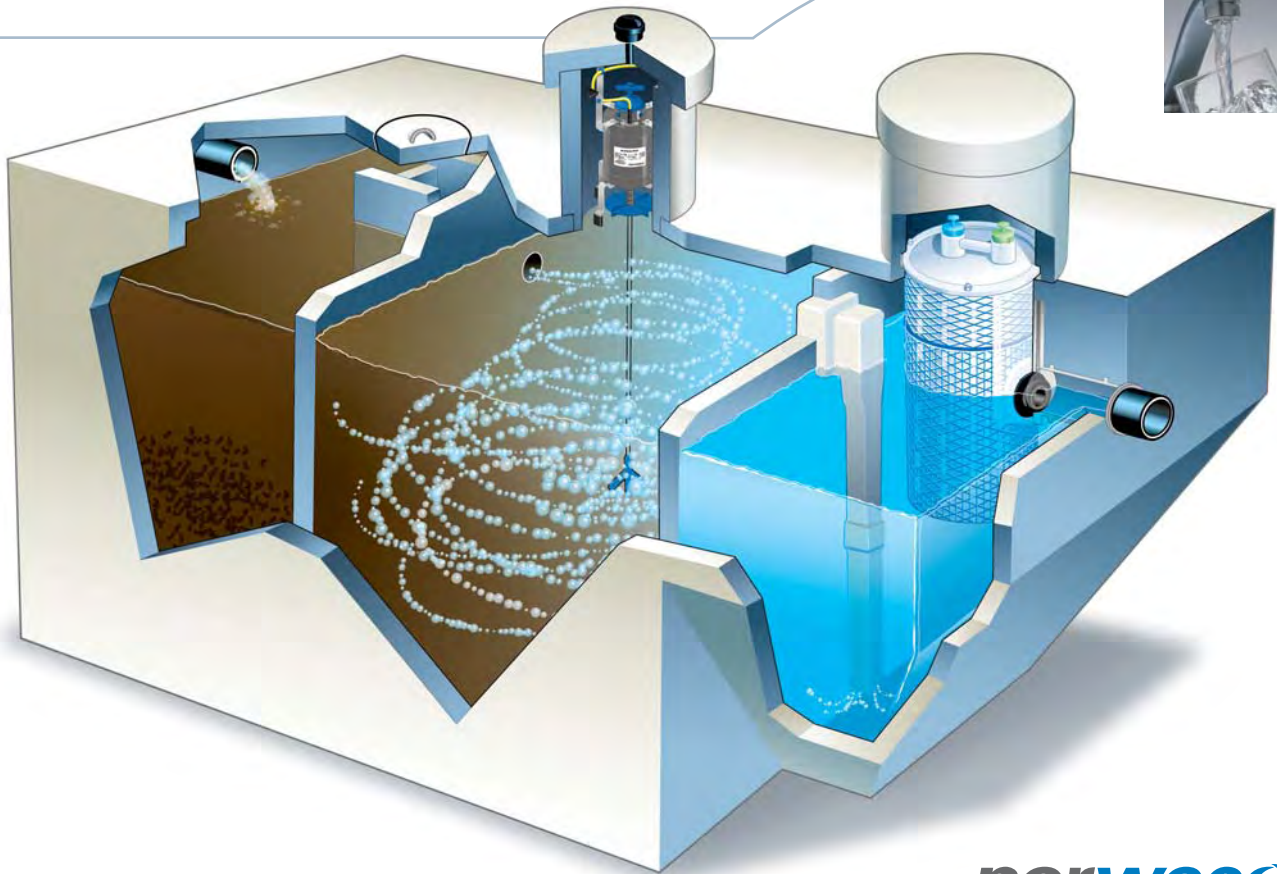

***norweco***®

*Engineering the future of water  
and wastewater treatment*



# SINGULAIR®

A dynamic combination of electro-mechanical equipment, solid state technology and web-based monitoring

that translates to increased property value, performance certified for you

The new state-of-the-art Singulair treatment system is the trouble-free, energy-efficient alternative to that out-dated, unmanageable septic tank. It sets a new standard for properties that are not connected to centralized sewers. It quietly, efficiently and automatically treats all incoming wastewater, returning harmless effluent to the environment in just 24-hours. Because it operates only 30-minutes every hour, the new Singulair uses half the energy required by continuous-run systems.

We've been providing progress through service since 1906. When you consider the facts presented in this brochure, you will see why Norweco is recognized everywhere as providing today's answer for the protection of tomorrow's environment.

solutions in wastewater treatment



Norweco distributors are located throughout the United States and much of the rest of the world. Research, product development, manufacturing, marketing and sales support are conducted inside our offices and factory in Norwalk, Ohio. Everyone at Norweco is committed to shaping the future of our industry.

# engineering the future

of water and wastewater treatment

## Specify Singulair®

Your local Norweco distributor is fully trained to install your Singulair System and any other Norweco product you choose to protect your environment. Each of our distributors has completed a nationally accredited Singulair factory-training program.

The Singulair System comes to you complete, including delivery, tank setting, equipment installation, plant start-up and service. A series of service and adjustment inspections are scheduled for the first two years of operation at the time your system is installed. These inspections are included in the sale so that your system continues to perform at the highest level to protect you and your investment. Extended service contracts are also available from your Norweco distributor.

# Singular® rivals the performance of the world's most advanced treatment equipment

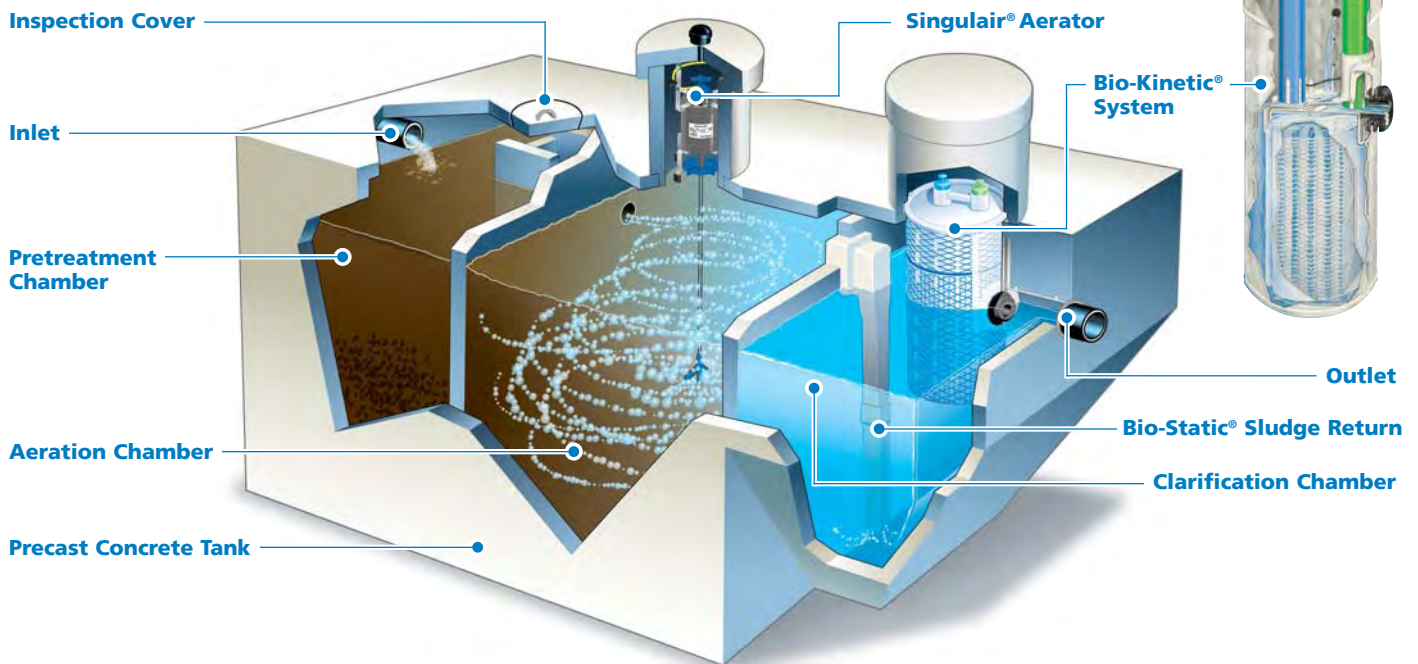

## Inlet

Untreated wastewater enters the system here.

## Pretreatment Chamber

Wastewater enters at the Singular inlet and is equalized here as anaerobic bacteria and gravity precondition it.

## Aeration Chamber

Here, safe, living aerobic bacteria convert the wastewater into stable substances. Flow equalization maximizes this biological oxidation and assures 24-hour retention and treatment.

## Aerator provides complete treatment

Our exclusive aerator infuses the fresh air that safe, living microorganisms require to fully digest and treat wastewater inside the Aeration Chamber. Powered by our 1725 RPM, 115 volt, fractional horsepower motor, our quiet, reliable aerator is inexpensive to operate, reduces heat build up and dramatically increases bearing life. Each aerator is precision engineered, tested and certified to operate only 30-minutes per hour. Only the stainless steel aspirator shaft and reinforced nylon aspirator come in contact with liquid in the Aeration Chamber.

## Clarification Chamber

Flow equalization enhances the settling of biologically active substances inside the Clarification Chamber. Wastewater has now been converted into clarified liquids in this chamber.

## Flow Equalization Ports

They control the flow through all upstream and downstream processes and they regulate the amount of treated effluent that can enter the Bio-Kinetic System.

## Bio-Kinetic® System

Constructed entirely of plastic and rubber components that are impervious to this environment, our Bio-Kinetic System combines filtration, settling, non-mechanical flow equalization, optional disinfection, adjustable outlet weir and optional dechlorination features into a single, revolutionary package.

## Precast Concrete Tank

Every Singular System is constructed of high quality, non-corrosive materials under our rigid quality control standards. The tank, access risers and cover are reinforced precast concrete manufactured locally by your factory-trained, licensed Norweco distributor.

## Inspection Cover

Access is safe and easy.

## Outlet

Only a clear, safe and odorless liquid exits the system here for return to your environment.



## SERVICE PRO® Control Center

EVERY SINGULAR AERATOR IS INSTALLED WITH A SOLID STATE ELECTRICAL CONTROL CENTER. EACH IS EQUIPPED WITH RESETTABLE CURRENT SENSOR, ON/OFF SELECTOR SWITCH, RED WARNING LIGHT, TIME CLOCK, AUDIBLE ALARM, AUXILIARY INPUTS AND FCC LICENSED AUTODIALER FOR REMOTE MONITORING OF INDIVIDUAL COMPONENTS.

Today's Answer for the Protection of Tomorrow's Environment



## comprehensive protection, guaranteed



Singulair is warranted against defects in material and workmanship under normal use and service by a comprehensive 50 year Warranty and Exchange Program.

This 2 year Limited Warranty and 48 year Exchange provides single source protection and covers all system components. Complete Warranty and Exchange information, a Warranty Registration Card and Owner's Manual are included with purchase.

The Singulair Bio-Kinetic System components have been listed, licensed and/or certified by each of the following agencies/organizations.



***norweco***<sup>®</sup>

*Engineering the future of water  
and wastewater treatment*

**220 Republic Street  
Norwalk, Ohio, U.S.A. 44857-1156  
PH: 419.668.4471  
FAX: 419.663.5440  
www.norweco.com**

*Progress Through Service Since 1906*

*We engineer, manufacture, install and maintain advanced water and wastewater treatment technologies for residential properties, communities and commercial properties that are not connected to sewer lines. Norweco treatment systems are in service all over the world.*

*Norweco<sup>®</sup>, Norweco.com<sup>®</sup>, Singulair<sup>®</sup>, Modulair<sup>®</sup>, Travalair<sup>®</sup>, Lift-Rail<sup>®</sup>, Microsonic<sup>®</sup>, Bio-Dynamic<sup>®</sup>, Bio-Sanitizer<sup>®</sup>, Bio-Neutralizer<sup>®</sup>, Bio-Kinetic<sup>®</sup>, Bio-Static<sup>®</sup>, Bio-Gem<sup>®</sup>, Bio-Regeneration<sup>®</sup>, Bio-Perc<sup>®</sup>, Blue Crystal<sup>®</sup>, ClearCheck<sup>®</sup>, ChemCheck<sup>®</sup>, Service Pro<sup>®</sup>, Grease Buster<sup>®</sup> and "BUSTER" logo are all registered trademarks of Norwalk Wastewater Equipment Company, Inc.*

***norweco***<sup>®</sup>

**SINGULAIR<sup>®</sup> BIO-KINETIC<sup>®</sup>**  
**WASTEWATER TREATMENT SYSTEM**  
**MODEL TNT**

**GENERAL SPECIFICATIONS**

The contractor shall furnish and install one complete Singulair Bio-Kinetic wastewater treatment system with all necessary parts and equipment as described in the following specifications. Treatment of the domestic wastewater shall be accomplished by the extended aeration process with non-mechanical flow equalization, pretreatment of the influent, and filtration of the final effluent. The treatment system shall provide primary, secondary, and tertiary treatment of the wastewater flow prior to discharge. All treatment processes shall be contained within reinforced precast concrete tankage meeting the requirements of ACI standard 318. The wastewater treatment system shall be a Singulair Model TNT as manufactured by Norweco, Inc., Norwalk, Ohio, USA. Systems utilizing fiberglass, steel, or plastic tankage are subject to floatation when dewatered and shall not be considered for this application.

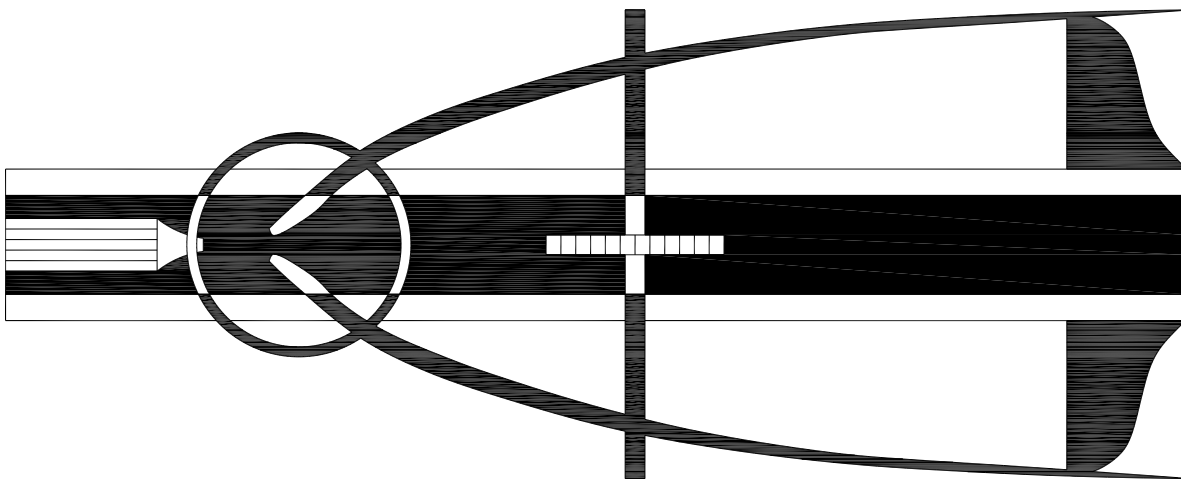

The wastewater treatment system shall include precast concrete tankage providing separate pretreatment, aeration and final clarification chambers. The tankage shall be furnished with cast-in-place inlets, submerged transfer ports, aerator mounting casting with removable cover, cast-in-place molded plastic vent assembly, cast-in-place outlet couplings and Bio-Kinetic system mounting casting with removable cover. Principal items of electro-mechanical equipment supplied with the Singulair system shall be a 1725 RPM mechanical aerator, UL listed Service Pro control center with MCD technology, Bio-Static sludge return and Bio-Kinetic tertiary treatment device for flow equalization and final filtration of system effluent.

**SPECIFICATIONS**

# SINGULAIR®

## OPERATING CONDITIONS

Total holding capacity of the system shall provide a minimum of 48 hour retention of the daily flow. The pretreatment chamber shall provide at least 18 hour retention, the extended aeration chamber shall provide at least 24 hour retention, and the clarification chamber shall provide at least 6 hour retention. The non-mechanical flow equalization device shall increase each individual chamber and total system retention time in direct proportion to loading. Design of the system shall include a compartmented tank and non-mechanical flow equalization device to insure successful treatment performance without upset even when the significant runoff period is six hours. Hydraulic design considerations of the system and flow equalization device shall be such that intermittent peak flow factors as high as four shall not upset hydraulic reliability within the system. Capability of the system to perform as outlined, when built by an approved manufacturer, shall be certified by an independent testing laboratory and approved for use by the local governing regulatory agency.

## PRETREATMENT CHAMBER

The pretreatment chamber shall be an integral part of the wastewater treatment system. All domestic wastewater shall be preconditioned and flow equalized while passing through the pretreatment chamber prior to being introduced to the extended aeration chamber. The outlet of the pretreatment chamber shall be equipped with a discharge tee that extends vertically into the liquid so that only the preconditioned equalized flow from the center area of the chamber is displaced to the extended aeration chamber. The discharge tee and transfer port shall be of adequate size to handle a peak flow factor of 4 without restricting the outlet and disturbing hydraulic displacement to the extended aeration chamber. A removable inspection cover shall be cast into the top of the pretreatment chamber to allow tank and transfer tee inspection. As a safety measure, the uncovered opening shall be small enough to insure that the tank cannot be entered for inspection or service.

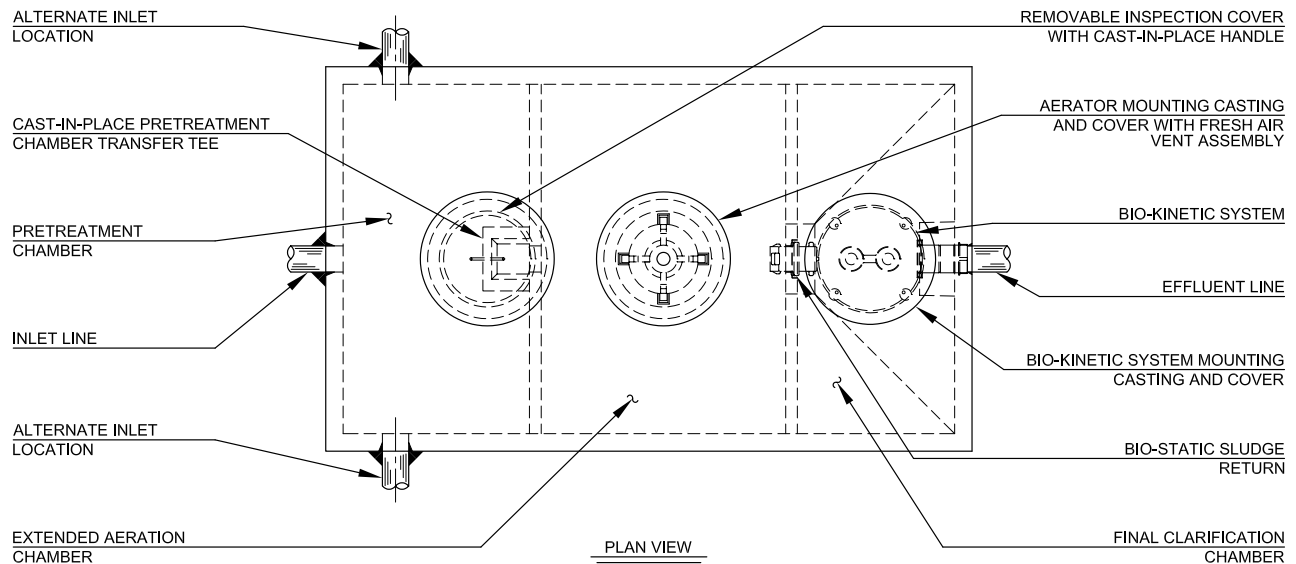

## AERATION CHAMBER

The extended aeration chamber shall provide in excess of 24 hour retention of the equalized daily flow. The chamber shall be of sufficient size to provide a minimum of 80 cubic feet of tank capacity per pound of applied BOD. The aeration chamber length-width-depth ratio shall be designed to insure uniform tank mixing and provide optimum treatment. The aeration chamber(s) shall be an integral part of the system flow path and constructed of properly reinforced 5,000 PSI, 28 day compression strength precast concrete. All castings used to construct the precast concrete tankage shall be monolithic units with external and internal walls incorporated into each section.



# FINAL CLARIFICATION CHAMBER

The final clarification chamber shall consist of 5 functionally independent zones operating together to provide satisfactory settling and clarification of the equalized flow. An inlet zone shall be provided and shall dissipate transfer turbulence at the flow inlet of the clarification chamber. Its performance shall also eliminate turbulence in other zones of the clarifier. Liquid shall be hydraulically displaced from the inlet zone to the sludge return zone. Hydraulic currents shall sweep settled sludge from the hoppers and return these solids via the inlet zone to the aeration chamber. As solids are removed, liquid is displaced to the hopper zone of the clarifier. In this zone, settling by gravity takes place. Three of the four sidewalls are slanted to form a hopper which directs all settled material back to the sludge return zone. Clarified liquid from the hopper zone shall be displaced into the final settling zone to provide additional clarification of the liquid. The liquid is finally displaced to the outlet zone for final filtration and discharge from the system. Non-mechanical equalization of the flow, through all 5 independent zones, shall provide optimal settling and clarification.

## BIO-STATIC® SLUDGE RETURN

A Bio-Static sludge return shall be installed into the cast-in-place opening(s) in the aeration/clarification chamber wall to provide positive return of settled solids. Aeration chamber hydraulic currents shall enter the sludge return(s) and be directed into the sludge return zone of the clarification chamber. The Bio-Static sludge return shall accomplish resuspension and return of settled solids without disturbing the clarified liquid in the final settling zone and outlet zone.

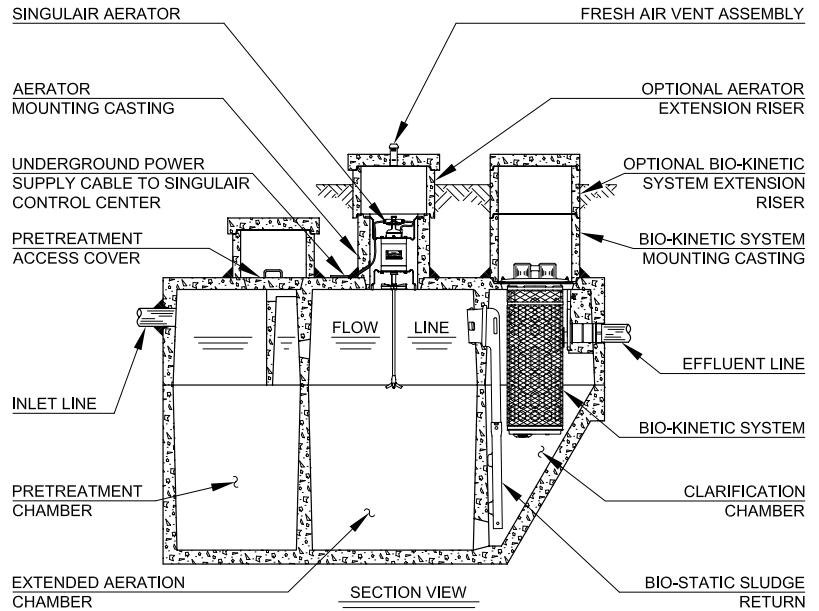

## MECHANICAL AERATOR

Each Singlair aerator shall be installed in a concrete aerator mounting casting above the aeration chamber. Fresh air shall be supplied through a molded plastic vent assembly cast into the concrete access cover above the aerator. The Singlair aerator shall include plated mounting brackets, NEMA 6 rated electrical connector, fractional horsepower motor, molded plastic lifting handle, molded plastic air intake screens, molded plastic foam restrictor, stainless steel aspirator shaft and molded glass-filled nylon aspirator tip. The motor shall contain precision manufactured o-ring type seals installed between the motor shell and the machined aluminum endbells to insure watertight integrity is maintained. Molded Viton elastomer shaft seals shall be utilized to protect the bearings from contamination. Only the stainless steel aspirator shaft and glass-filled nylon aspirator tip shall be installed in contact with the liquid. There shall be no submerged electrical motors, bearings, or fixed air piping in the aeration system. Singlair aerator motors shall be designed not to exceed the motor nameplate rating when installed and operated as recommended for the system. The fractional horsepower aerator motor shall be equipped with a foam restrictor to protect the motor against high water and foam. The motor shall be 4 pole, 1725 RPM, 115 volt, 60 Hertz, single phase, ball bearing constructed with a 1.0 service factor. It shall draw less than 4.0 amps when operating at the rated nameplate voltage. Aerator motors operating at speeds in excess of 1800 RPM experience increased bearing wear, increased operating costs and heat build up, and shall not be considered for this application.

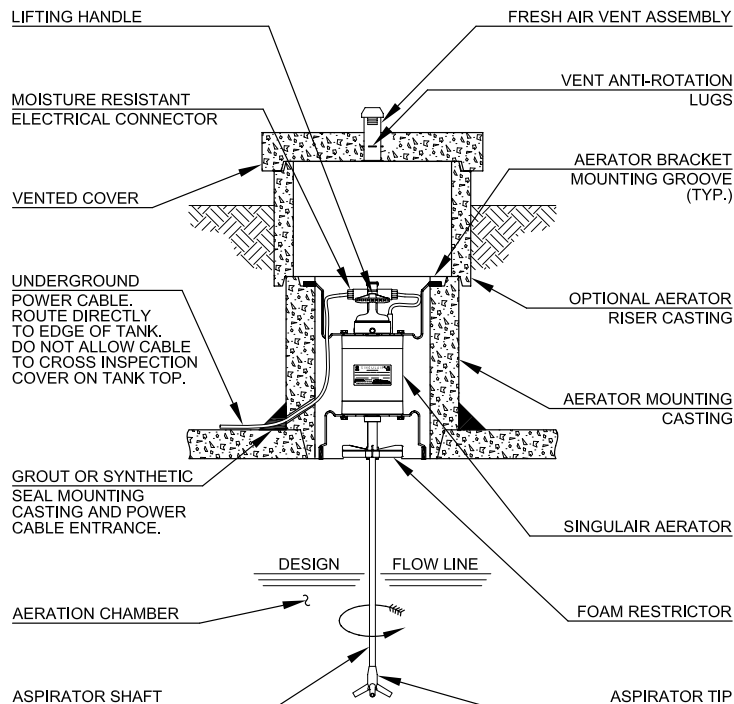

# BIO-KINETIC®

## SERVICE PRO® CONTROL CENTER

The Service Pro control center with MCD technology shall provide Monitoring, Compliance and Diagnostic functions for the Singular treatment plant using a microprocessor based platform. The Service Pro control center shall contain nonvolatile memory to prevent loss of programming in the event of a power failure. The pre-wired controls shall be mounted in a lockable NEMA rated enclosure designed specifically for outdoor use. Each Service Pro control center shall be a UL listed assembly and shall include an alarm light, reset button, power switch, power light, phone light, aerator alarm light and three auxiliary alarm lights. The control center shall monitor all treatment system operating conditions including aerator over current, aerator under current or open motor circuit. In the event the control center detects one of these conditions, power to the aerator shall be interrupted, a diagnostic sequence shall begin and the visual alarm shall activate. After a programmed recovery interval, an automatic restart attempt shall be initiated. If normal aerator operation does not resume during 24 programmed recovery and restart cycles, the audible alarm shall activate and the telemetry system shall report the specific condition to the Service Pro monitoring center. In the event that any of the auxiliary inputs detect abnormal operation of the treatment system auxiliary equipment, the audible and visual alarms shall immediately activate and the telemetry system shall report the alarm condition to the monitoring center. The service provider shall automatically be notified by the Service Pro monitoring center of the specific alarm condition using phone, fax or email.

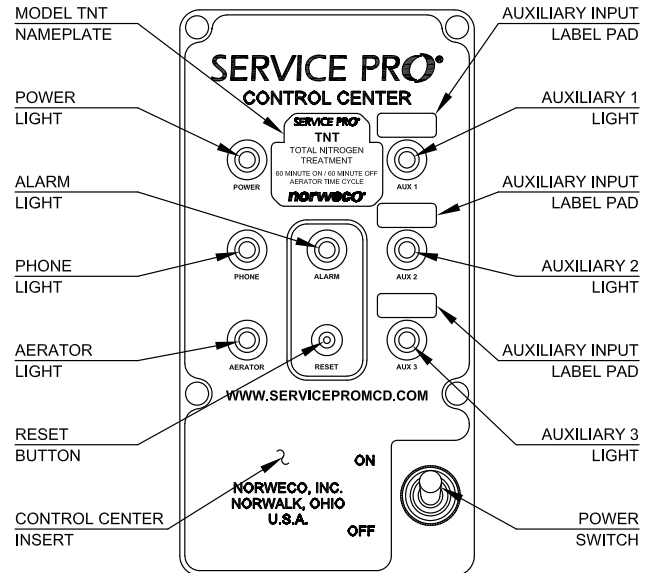

## SERVICE PRO® MONITORING CENTER

The Service Pro monitoring center shall include a 128 bit encrypted password protected website for interface with the monitoring center database. Access to the secure website shall be obtained through a unique user name and password that provides tiered access to data from monitored treatment systems. Tiered access levels shall include distributors, service providers, regulatory agencies and individual system owners. Distributors and service providers shall be able to create accounts, maintain service records and grant regulatory agencies access to the information. Individual system owners shall be able to view information regarding their own systems, as well as download instructional information. Integrity of stored data shall be maintained through the use of multiple servers maintained in geographically isolated locations.



# SPECIFICATIONS

## BIO-KINETIC® SYSTEM

A Bio-Kinetic system shall be installed in the mounting casting(s) above the clarification chamber. Each Bio-Kinetic system shall provide non-mechanical flow equalization through all plant processes including pretreatment, aeration, clarification, tertiary filtration, chlorination and dechlorination. The assembly shall be supplied with locking lugs and removable moisture/vapor shield and shall consist of a design flow and peak flow micronically molded filter, baffled perimeter settling zone, flow distribution deck, lifting handles, level indicator, adjustment lugs, unbaffled perimeter settling zone, solids contact zone, vertical inlet zone, compartmented settling zone consisting of 42 baffled chamber plates, effluent stilling well, final discharge zone, adjustable outlet weir, outlet zone and gasketed discharge flange. All components shall be manufactured from inert synthetic materials or rubber, assembled in circular fashion and connected to a plastic outlet coupling. The outlet coupling shall accept a 4" diameter, Schedule 40, PVC pipe. Each Bio-Kinetic system shall be installed with the inverts of the design flow equalization ports located at the normal liquid level of the clarifier. If intermittent flow rates exceed the capacity of the design flow ports, flow shall be held upstream until the intermittent flow dissipates. If the intermittent flow continues to increase, the liquid level may reach a pair of sustained flow equalization ports. With four ports in use, flow through the system increases while continuing to provide flow equalization to all upstream and downstream processes. Peak flow equalization ports are supplied but should not be required in a properly sized system.

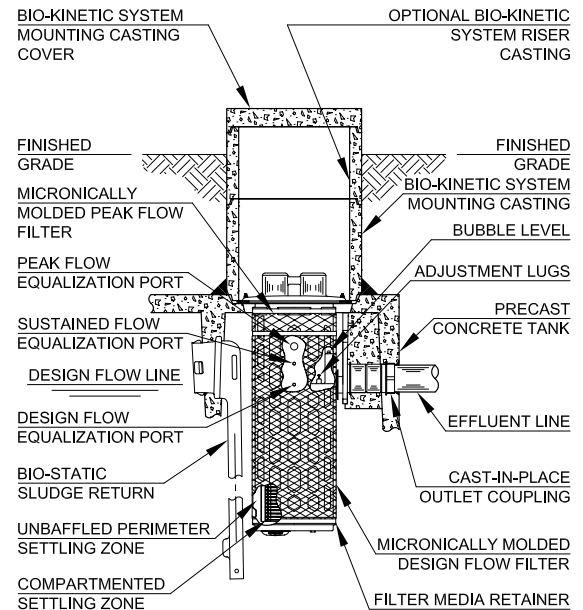

## FLOW EQUALIZATION

The wastewater treatment system shall include a non-mechanical, demand use, flow equalization device. The device shall control normal residential flow rates and reduce typical residential flow surges. The flow equalization rate shall be dependent upon the specific loading pattern and the duration of flow surges. At the 500 gallon per day NSF Standard 40 design loading schedule, minimum performance of the device shall equalize daily flow an average of 48%.

## WARRANTY AND EXCHANGE PROGRAM

The manufacturer shall provide a two year limited warranty for the Singulair aerator, Service Pro control center, Bio-Kinetic system and Singulair precast concrete tank. A comprehensive exchange program offers Singulair owners an additional forty-eight years of equipment protection. The distributor shall provide warranty and exchange program details to the regulatory agency, contractor and customer as required.



## EQUIPMENT MANUFACTURER

The equipment specified herein shall be the product of a manufacturer having a minimum of seven years experience in the construction of prefabricated wastewater treatment equipment and systems. Bids shall be prepared on the basis of the equipment and material specified herein for purposes of determining the low bid. This is not done, however, to eliminate other products or equipment of equal quality and efficiency. If equipment is to be substituted, approval of such substitution must be made prior to execution of any order. It is assumed that substitution will result in a reduction of cost to the contractor and that if accepted, these savings will be passed along by a reduction in the base bid.

## SINGULAIR® MODEL TNT DATA CHART

Designation:	500 GPD
Daily Treatment Capacity (Gallons Per Day)	500
Number of Singulair Aerators	1
Number of Bio-Kinetic Systems	1
Number of Bio-Static Sludge Returns	1
Drawing Number (PC-5)	7102

**PROGRESS THROUGH SERVICE SINCE 1906**

***norweco***®

*Engineering the future of water  
and wastewater treatment*

220 REPUBLIC STREET  
NORWALK, OHIO, USA 44857-1156  
TELEPHONE (419) 668-4471  
FAX (419) 663-5440  
www.norweco.com

**DISTRIBUTED LOCALLY BY:**

Norweco®, Norweco.com®, Singulair®, Modulair®, Travalair®, Lift-Rail®, Microsonic®, Bio-Dynamic®, Bio-Sanitizer®, Bio-Neutralizer®, Bio-Kinetic®, Bio-Static®, Bio-Gem®, Bio-Regeneration®, Bio-Perc®, Blue Crystal®, ClearCheck®, ChemCheck®, Service Pro®, Grease Buster® and "BUSTER" logo® are registered trademarks of Norwalk Wastewater Equipment Company, Inc.

©MMVII NORWECO, INC.

# ***norweco***® **SINGULAIR**®

## **BIO-KINETIC® WASTEWATER TREATMENT SYSTEM INSTALLATION INSTRUCTIONS**

Each Singulair Bio-Kinetic wastewater treatment system is sold complete including: delivery and installation of the tank and Bio-Static sludge return; installation and start-up of the mechanical aerator, control center and Bio-Kinetic system; two-year limited warranty with four prescheduled service inspections at six month intervals; and fifty-year aerator exchange program. A clear outline of responsibilities when the order is placed will simplify installation of the system and establish a sound working relationship with the installing contractor and local health department.

### **INSTALLATION PROCEDURE**

Installation of the Singulair system normally occurs in two phases. First, the precast concrete tankage is delivered and installed at the contractor's convenience. Each electrical control center, underground electrical service cable and Bio-Static sludge return is also installed at this time. Only when the system is ready for start-up are the Singulair aerators and Bio-Kinetic systems delivered and installed. When the Singulair installer has completed equipment installation, he should also start-up and test the entire system and familiarize the owner with its operation. This installation procedure will assure efficient use of the contractor's and installer's time and protect equipment from possible damage or unauthorized start-up.

### **CONTACT THE LOCAL HEALTH DEPARTMENT**

The contractor must contact the local health department prior to installation of the Singulair system and apply for an installation permit. The local Singulair distributor will have drawings, specifications and performance data for the system on file with the health department. Normally, the contractor will not be required to supply this information to receive the installation permit. The health department may request a drawing showing the proposed method of effluent disposal and location of the Singulair system in relation to the building, property lines and potable water supply. The health department may wish to inspect the site and proposed point of discharge, take soil samples or run percolation tests before issuing an installation permit. The contractor must find out if an inspection of the Singulair tank and sewer line will be required before backfilling is allowed.

### **DELIVERY TRUCK ACCESSIBILITY**

Inform the contractor of the dimensions and weight of the delivery truck. The excavation must be accessible without interference from trees, shrubbery, power lines or other obstacles. Earth from the excavation must be piled outside the working area needed to operate the truck. Remind the contractor that extra charges will apply if the excavation is not complete and readily accessible.

### **POSITIONING THE EXCAVATION**

The Singulair tankage has three potential inlet locations. They are located on the inlet end wall and both inlet sidewalls at the same elevation. Any one of these inlets may be used. The position of the system with respect to the building, inlet sewer line and point of discharge will dictate the best inlet choice. It is not necessary to position the system with the inlet end wall facing the building. The pretreatment tank should be located in-line with the Singulair tank and the excavation should be sized approximately one foot wider and one foot longer than the pretreatment tank dimensions. Allow for a short distance between the tanks for installation of the submerged transfer port.

### **EXCAVATION SIZE AND DEPTH**

The Singulair tank is 9' 3" long and 5' 6" wide. To allow adequate room for tank installation, the excavation should be at least 10' 6" long by 6' 6" wide. Additional overdig will be required on deeper installations or for safety where the excavation side walls are unstable. If the system requires an external pretreatment chamber, the excavation size must be increased accordingly.

The excavation depth is calculated using two factors. First, note the elevation of the sewer line as it leaves the building. From this sewer line elevation, subtract  $\frac{1}{8}$ " per foot from the building to the system location. Next, subtract the dimension from the outside bottom of the tank to the inlet invert of the system as determined from the following chart:

<b>SYSTEM SIZE</b>	<b>INLET INVERT</b>
500 GPD	5' 0"

Confirm the dimension from your pretreatment tank before excavation takes place. The remainder is the finished excavation depth. Fall through the system from inlet invert to outlet invert is 0' 4". Therefore, the outlet line from the system must be installed four inches lower than the point where the inlet sewer line joins the system.

# INSTALLATION INSTRUCTIONS (Cont.)

## TANK LEVELING PAD

To insure that the tank bottom will be bearing the weight evenly, all tanks should be set on a four inch thick pad of gravel, sand or fine crushed stone. The pad should be installed and leveled by the contractor before delivery and setting of any tank takes place. The tank pad must be leveled to within 1/4" from side to side and end to end.

## BACKFILLING THE TANKAGE

**CAUTION:** Do not allow dirt, debris or other material to enter the Singulair system during installation or backfilling. The Singulair system must be backfilled immediately after installation. Any fine, granular jobsite material or backfill may be used. Large clumps of earth, rocks or debris should never be used to backfill around the system. The slanted endwall beneath the clarifier must be backfilled with particular care. Be sure it is completely backfilled so that future settling will not cause a low spot in the finished lawn or place an undue strain on the outlet line.

## FILLING THE SYSTEM WITH WATER

The Singulair system should be filled with clean water immediately after installation. Water should be added as the tank is being backfilled to equalize internal and external tank pressure. Fresh water is preferred but water from a nearby pond may be used if it is free of silt and other debris. A septic tank pumping service should never be used to fill the Singulair system. If this is done, large amounts of biologically untreatable materials may be deposited in the system and they could interfere with system operation and performance.

## INLET SEWER LINES

Only domestic wastewater must be allowed to enter the Singulair system. It is not intended to handle flows from roofing down spouts, basement footer drains, sump pump piping or garage and basement floor drains. If the sanitary sewer system must be used for disposal of these liquids, it must be connected downstream of the Singulair system. Water softener backwash will affect system performance and must not flow into the Singulair system.

## ELECTRICAL POWER SUPPLY

A dedicated 115 volt AC single phase, 10 amp (minimum) 60 Hertz circuit must be provided in the main electrical service panel for each Singulair control center.

## FINISH GRADING AND LANDSCAPING

A precast concrete aerator mounting casting with vented cover is provided for each aerator and extends twenty inches above the top of the Singulair tank. The top of each cover must project a minimum of 6" above finished grade. Individual precast concrete riser castings may be added in

12" increments when necessary. If possible, determine if riser sections will be needed before tank installation is scheduled.

A precast concrete system mounting casting with non-vented cover is provided for each Bio-Kinetic system. The top of each cover must project a minimum of 6" above finished grade. Individual precast Bio-Kinetic system riser castings may be added in 12" increments when necessary. If possible, determine if riser sections will be needed before tank installation is scheduled.

## PRETREATMENT CHAMBER ACCESS

A precast concrete system mounting casting with non-vented cover is provided to bring the pretreatment chamber access opening above grade. The top of each cover must project a minimum of 6" above finished grade. Individual precast riser castings may be added in 12" increments when necessary.

MANUFACTURED BY

***norweco***<sup>®</sup>

*Engineering the future of water  
and wastewater treatment*

**NORWECO, INC.  
NORWALK, OHIO  
U.S.A. 44857**

**[www.norweco.com](http://www.norweco.com)**

# **norweco® SINGULAIR®**

## **BIO-KINETIC® WASTEWATER TREATMENT SYSTEM TANK DELIVERY AND SETTING**

To insure that all work proceeds safely and efficiently, check these items prior to delivery of the Singulair tankage.

- ✓ Does the driver have complete and accurate directions to the installation?
- ✓ Does the driver have the Singulair installer's tool kit?
- ✓ Are the appropriate number of aerator mounting castings, Bio-Kinetic system mounting castings, extension riser castings and vented and non-vented access covers included?
- ✓ Is there an adequate supply of sealing material for the tank and all plumbing connections?
- ✓ Does the truck have the proper pick-up bar and cable (or chain)?
- ✓ Are the proper quantity and size of Bio-Static sludge returns installed?
- ✓ Are the proper quantity of Singulair control centers available for delivery with the tanks?
- ✓ Is there sufficient underground electrical cable to reach from the control center location to the tank?

**PLEASE NOTE:** *The Singulair tank is constructed of monolithic castings and, if possible, the joints should be sealed at your plant before setting. This will minimize tank loading, unloading and setting time at the site. The castings may be set individually and sealed at the site if necessary. These instructions are written as if the castings will be installed separately and sealed at the site. However, the tank should be assembled and sealed in your plant if your tank handling and delivery equipment will allow it. Otherwise, proceed with tank setting as outlined herein.*

### **CHECKING THE EXCAVATION**

Before tank setting begins, the length, width and depth of the excavation should be checked. The excavation should have sufficient overdig to allow for a minimum of 6" of clearance around the entire perimeter of the Singulair system. Additional overdig will be required on deep installations or where unstable soil conditions exist. Safe working conditions must be established and maintained during the entire installation procedure.

Check the influent and effluent sewer line trenches. The depth should correspond with the Singulair system inlet and outlet connections and the trenches should be smooth to prevent damage to the sewer lines.

A tank leveling pad should be installed in the bottom of the excavation. The pad should be a minimum of 4" thick and leveled to within  $\frac{1}{4}$ " from side to side and end to end. The elevation of the top of the leveling pad should correspond to the outside bottom of the Singulair precast concrete tankage when installed.

Extreme care should be used any time personnel or equipment are in the vicinity of any excavation. A delivery truck can place excessive loading on excavation sidewalls and care must be taken in its positioning. Unstable soil

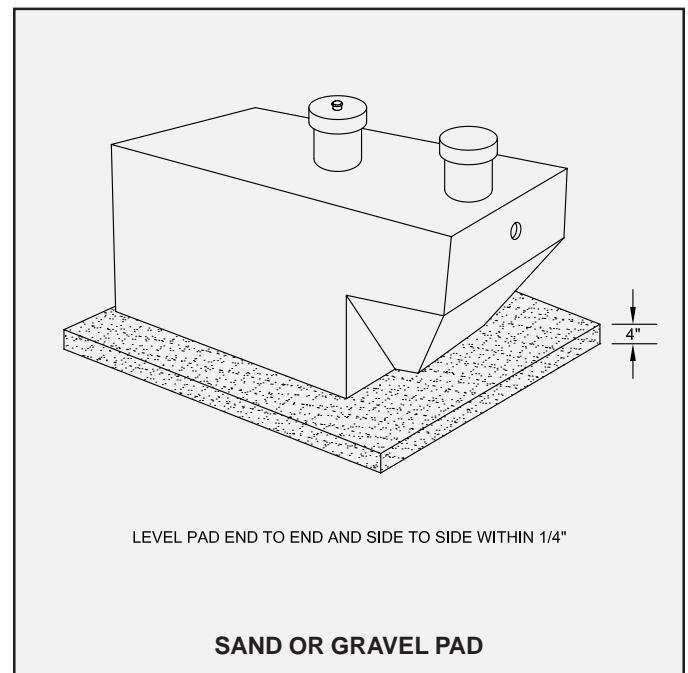

conditions require constant monitoring of the site to insure safety. Construction and installation procedures, equipment, tools, materials and personnel should always comply with applicable safety regulations and federal, state and local codes.

## TANK DELIVERY AND SETTING (Cont.)

### SINGULAIR TANK SEALING

While the tank bottom is still on the delivery truck, remove any concrete chips, stones, mud or debris from the groove in the casting and from the floor of the pretreatment and aeration chambers. Be sure the transfer port is clean and unrestricted. Apply a good quality mastic sealant into the groove of the bottom casting around the entire perimeter and fully across both internal baffles. Inspect the sealant after application to eliminate any gaps or uneven spots. A non-shrinking grout sealant may be used in place of mastic, but mastic will allow the tank to be filled with water immediately after its installation.

### TANK SETTING AND SAFETY

With the delivery truck in position at the excavation, make sure that its outriggers are firmly placed on stable soil. All personnel must be out of the excavation and a safe distance from the tank. Before lifting the tank, check all lifting chains to be sure they are properly seated in the casting pick-up grooves. Lift the tank bottom section and place it directly into the excavation. Do not set it down. Stop the casting several inches above the excavation floor and position it in the desired location. Now lower it carefully until all tension is off the lifting cable or chain.

truck. The casting should then be reset after the excavation has been properly leveled.

The top casting may now be set. Remove all debris from the bottom of the casting along the tongue sealing section. Do not reach or get under any portion of the casting. Carefully position the top and lower one corner into the groove. Align the sides of the casting and lower the top into position. Before proceeding with Bio-Static sludge return assembly and installation, recheck the tank for level from side to side and end to end.

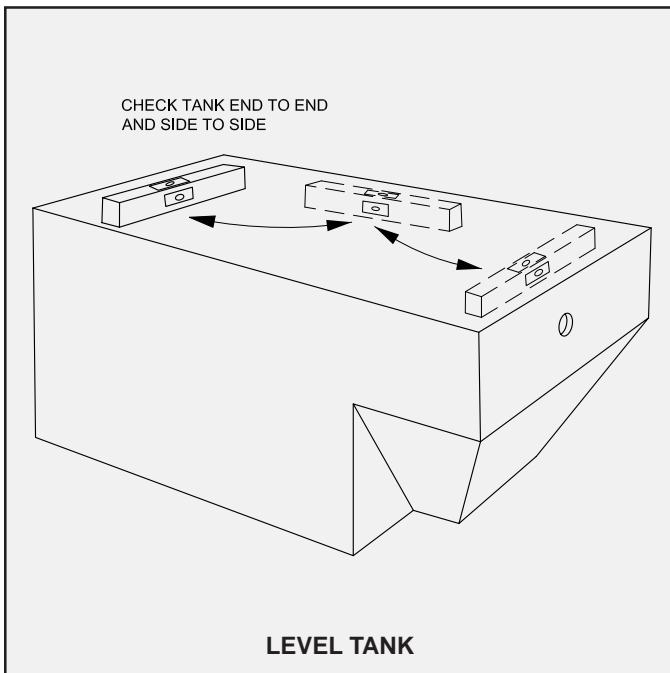

Place a level on the exposed joint and check the casting for level from end to end and side to side (if the tank is set as one piece, check for level on the top). It must be level within 1/4" from end to end and from side to side. The casting may need to be raised slightly so additional leveling pad material can be applied before level is achieved. If the casting needs to be raised more than six inches to apply leveling material, the contractor's personnel should move to a safe location so the casting can be fully returned to the bed of the delivery

MANUFACTURED BY

***norweco***<sup>®</sup>

*Engineering the future of water  
and wastewater treatment*

**NORWECO, INC.  
NORWALK, OHIO  
U.S.A. 44857**

**[www.norweco.com](http://www.norweco.com)**



# SINGULAIR® BIO-KINETIC®

## WASTEWATER TREATMENT SYSTEM

### TANK DELIVERY AND SETTING (Cont.)

#### BIO-STATIC SLUDGE RETURN ASSEMBLY

Bio-Static sludge returns consist of inlet and extension sections and must be assembled prior to installation in the Singulair tank. Insert the small end of the inlet section into the socket end of the extension section until the retainer pins snap into position. A two piece assembly is used for 500 GPD systems.

#### BIO-STATIC SLUDGE RETURN INSTALLATION

All Bio-Static sludge returns must be installed through the openings in the top of the clarification chamber, prior to installation of the Bio-Kinetic system mounting castings. A single Bio-Static sludge return assembly is installed in 500 GPD systems. After the sludge return has been assembled to the correct length, it should be installed into the opening in the clarification chamber wall. Securely grasp the assembled sludge return by the inlet with the opening facing away from you. Lower the assembly through the clarification chamber access opening in the top of the tank. Firmly push the inlet of the sludge return through the opening in the clarification chamber wall until the four retainer lugs snap

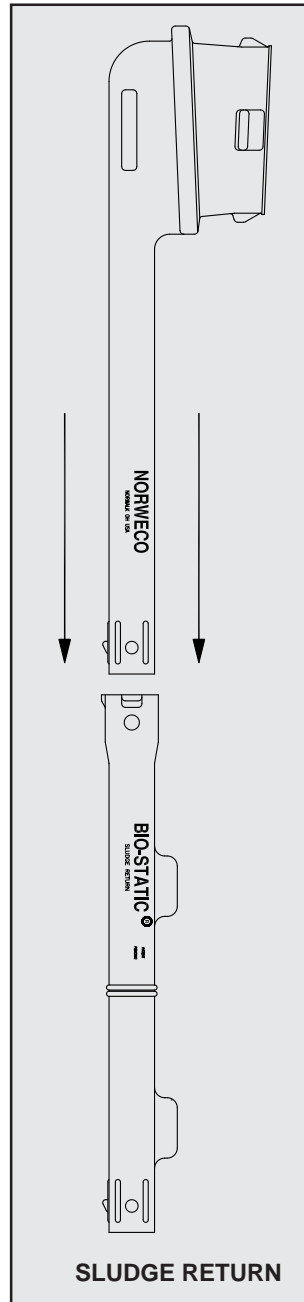

into position and the assembly is securely mounted. The standoff on the lower most extension piece should be touching the clarification chamber wall just above the transfer port. Repeat these steps when two Bio-Static sludge returns are required.

#### MOUNTING CASTING AND OPTIONAL EXTENSION RISER INSTALLATION

Locate the power cable entrance in each aerator mounting casting. It should be inspected for flash or sharp edges. Be sure it extends all the way through the casting side wall. Remove the cast-in access cover from the top of each aeration chamber. Apply a strip of mastic sealant around the perimeter of each access opening. Position and install each aerator mounting casting with the power cable entrance facing the tank side wall that is closest to the building. Be sure that each mounting casting is properly seated on the tank top and evenly sealed with mastic. If extension riser castings are required, install them as needed above each aerator mounting casting. Apply mastic sealant to all joints between castings. Do not apply sealant to the top of the mounting casting or riser that will receive the vented access cover.

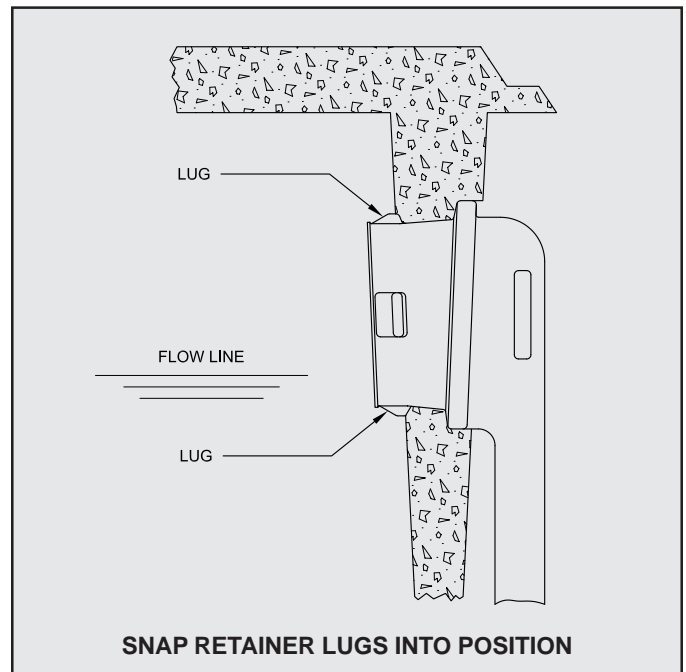

## TANK DELIVERY AND SETTING (Cont.)

The pretreatment chamber can be made accessible at grade or left below grade, as required by local regulation or owner preference. The inspection cover on the pretreatment chamber must at least be developed to within twelve inches of finished grade. Pretreatment chamber access covers should never be vented and should be sealed with mastic. Be sure all cast-in access opening covers that are not extended to grade are properly aligned, seated and secured in place. Tank covers which have been replaced by Bio-Kinetic or aerator mounting castings should be returned to your plant with the delivery truck. Install all covers for aerator mounting castings, Bio-Kinetic system mounting castings, risers and inspection ports before backfilling begins.

### SEWER LINE INSTALLATION

Sewer lines may be installed as soon as the Singulair concrete tankage has been leveled and sealed. Sewer line trenches must be smoothly excavated and free of debris or sharp-pointed objects that could damage the installation. The trenches must allow sewer lines to be laid with  $\frac{1}{8}$ " of fall per lineal foot of run along the entire length of the line. Influent and effluent sewer lines must be at least four inches in diameter. The influent line should be grouted into the Singulair system tank inlet. The effluent line should be PVC pipe, solvent welded into the Singulair outlet coupling. Inlet and outlet lines must be laid continuously and unspliced from the tank to undisturbed earth beyond the limits of the tank excavation. High quality PVC or other

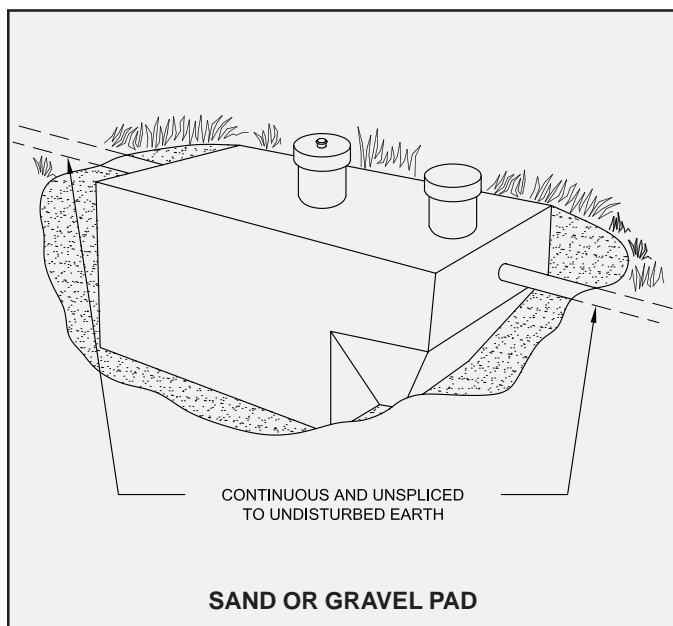

similar materials may be used for sewer lines, subject to the approval of local codes. Be sure the sewer lines are constructed with compatible fittings and joining materials throughout. Underground electrical cable for electrical service to each Singulair aerator should be installed in the sewer line trench before backfilling. Refer to Electrical Wiring and Control Center Installation instructions for complete details.

### BACKFILLING

The Singulair tankage should be backfilled immediately after sewer lines and underground electrical cable are installed. Fine, loose earth should be used to backfill the tank excavation and sewer line trenches. Be sure it is completely free of rocks, large clumps of earth and construction debris. Backfill evenly around the entire perimeter of the tank rather than all at once on each side. Take care to completely fill in the cavity beneath the slanted clarifier end wall. Final grading should be six inches below the top of each access cover and should slope away from the tank so surface runoff will drain away from the Singulair system. Use extreme care in backfilling. Do not allow dirt or mud to enter any part of the Singulair system or sewer lines. If dirt or mud enters any portion of the system, it must be removed to insure proper system operation. Removing the dirt or mud may require repeated flushing and tank pumping.

### TANK HOLD DOWN WATER

Each compartment in the Singulair system must be filled with clean water. The water should be free of leaves, mud, grit, oils or other materials that might possibly interfere with system operation. The tankage should be filled with water as it is backfilled to reduce stress on the precast concrete tank. Do not fill the Singulair tank with water through the opening in the top of the clarification chamber. The clarification chamber will be filled by adding water to the aeration chamber. In systems with more than one aeration chamber, each aeration chamber should be filled separately. In all systems, pretreatment chambers should be filled through their access openings.

This completes the portion of the installation that requires a delivery truck for tank lifting and setting. Installation of the electrical control center and underground electrical cable are normally completed by the delivery truck driver before leaving the site. Refer to Electrical Wiring and Control Center Installation instructions for details.

MANUFACTURED BY

***norweco***<sup>®</sup>

Engineering the future of water  
and wastewater treatment

**NORWECO, INC.  
NORWALK, OHIO  
U.S.A. 44857**

**[www.norweco.com](http://www.norweco.com)**

# ***norweco***® SERVICE PRO®

## CONTROL CENTER WITH MCD TECHNOLOGY

# INSTALLATION AND OPERATION INSTRUCTIONS

The advanced integrated circuitry of the Service Pro control center simplifies the Singulair installation, improves system performance and allows for communication with the Service Pro website. The control center insert and enclosure provide space for wiring connections and allow removal of the insert via a convenient plug connector. The integrated circuitry continually monitors both motor over current and under current conditions and minimizes nuisance alarm conditions using the automatic restart feature. To reduce unnecessary service calls, the control center shuts down the Singulair aerator in the event of an over current or an under current alarm condition, illuminates the alarm light and begins an automatic two hour aerator restart attempt sequence before activating the audible alarm and telemetry system.

Each Service Pro control center is equipped with an automatic telemetry system programmed with a toll free telephone number. In the event of an alarm condition that cannot be corrected by the control center's self-diagnostic sequence, the dialer calls out to the Service Pro remote monitoring center. Upon receipt of the call, the monitoring center identifies the alarming control center and logs the call time and specific alarm condition reported. The monitoring center then automatically updates the website and notifies the responsible Norweco distributor or service provider by email, fax or telephone. In addition to documenting alarm conditions, the website tracks the date, time and duration of service visits, service contract renewals and maintains a complete database for every Singulair system registered. Access to the information is password protected and available to licensed distributors, sponsored service providers, health departments and system owners.

These instructions are not intended to be a complete electrical or telecommunication system installation reference. Telecommunication system policies and electrical code requirements vary according to geographic area. Consult your local policies and regulations prior to installing the Service Pro control center. Refer to the Electrical Wiring and Control Center Installation instructions for additional details. These instructions are intended to give an understanding of the unique features of the Service Pro control center.

### INSTALLATION OF ELECTRICAL CONTROL CENTER

Although the aerator is not installed until system start-up, the Service Pro control center should be wired for operation when the tank and underground electrical cable are installed. Complete steps 1 through 10 of the "Underground Electrical Cable Installation" section of the Electrical Wiring and Control Center Installation instructions. The control center should be located so the warning light can be seen and the audible alarm heard. The mounting location should minimize exposure to direct sunlight, freezing rain or conditions that might prevent routine inspection or access. The control center should always be mounted out of the reach of children. If the Singulair system is to be remotely monitored, the steps in the Getting Started Website Instructions can be completed either before or after Service Pro control center installation.

Detach the control center cover from the enclosure and remove the insert from the mounting posts. Squeezing the top and bottom latches of the four pin power connector, unplug it and set the control center insert aside. Remove the three 1/2" knockouts in the bottom of the control center enclosure and install a conduit connector in each opening. Remove the knockout for the telephone grommet only if the control center's automatic telemetry feature will be used. For installations requiring a NEMA 3R rated enclosure, remove the 1/8" drain opening knockout. Exposed wiring to

or from the control center should always be enclosed in conduit. **NOTE: Be sure to assemble the hub to the conduit before connecting the hub to the enclosure.** Mount the enclosure securely using masonry nails, wood screws or common nails as appropriate. The following steps

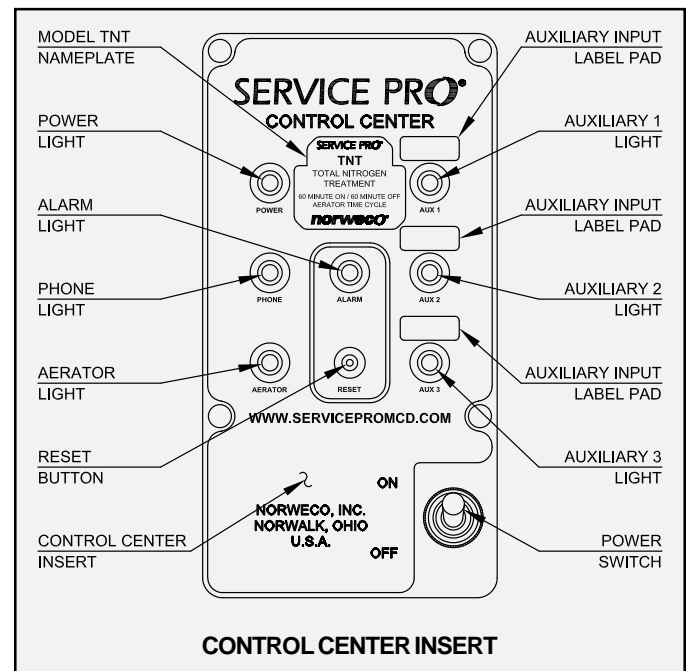

# SERVICE PRO® CONTROL CENTER INSTRUCTIONS (Page 2 of 6)

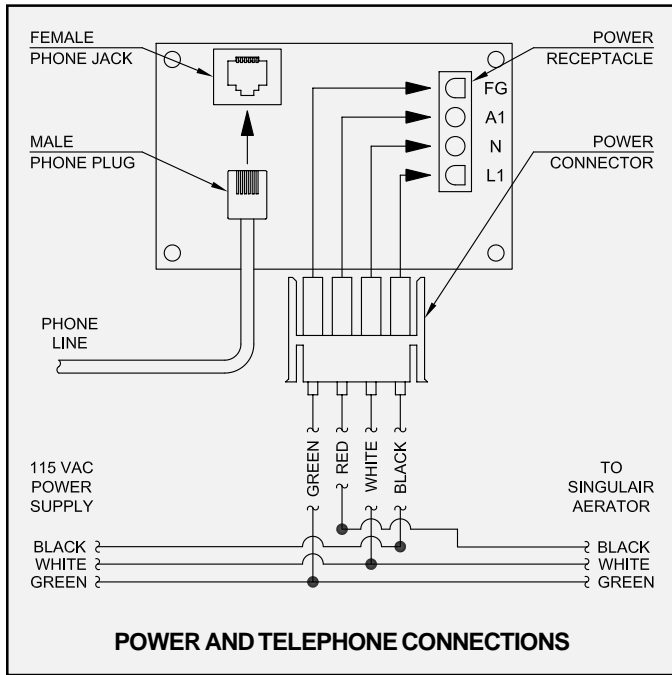

together and secure the connection with a yellow wire nut connector.

**CAUTION: Never allow the white neutral leads and ground leads to be spliced together or connected to common terminals. Failure to connect the Service Pro control center to a proper ground will void the Singlair system warranty.**

5. Connect the black lead of the underground electrical cable from the aerator to the red wire attached to the four pin power connector. Use at least #14 AWG black solid copper wire. To connect to the power connector lead, strip off the insulation jacket  $\frac{7}{16}$ " from the end of each wire lead. Twist the stripped leads together and secure the connection with a yellow wire nut connector.
6. If auxiliary alarm inputs are being used, skip to AUXILIARY ALARM INPUTS.
7. Inspect your work to make sure there are no breaks in wiring insulation and that all connections are secure.
8. Before installing the control center insert, energize the circuit breaker in the main electrical service panel and with your electrical multi-meter, test the voltage being supplied. Set up the meter to read AC voltage on the 0-150 volt scale. Place one probe of the meter on the power connector pin attached to the black lead and one probe on the power connector pin attached to the white lead. It should read between 109 and 121 volts. If it is within these limits, place one probe of the multi-meter

should be performed by the installing electrician to complete system wiring:

1. Use a dedicated 115 volt AC, single phase, 15 amp (maximum) circuit breaker in the main electrical panel for service to each Singlair aerator.

**CAUTION: Make sure the circuit is de-energized. Check it with an electrician's test light before proceeding. Remember that other circuits in the service panel may remain energized as you are working. Use only tools with insulated handles, stand in a dry location and work with extreme care.**

2. Run black wire from the dedicated breaker in the main service panel to the black wire attached to the four pin power connector. Use at least #14 AWG black solid copper wire. To connect to the wire leads, strip off the insulation jacket  $\frac{7}{16}$ " from the end of each insulated wire lead. Twist the stripped leads together and secure the connection with a yellow wire nut connector.
3. Wire from the neutral in the main service panel to both the neutral wire in the underground electrical cable from the Singlair aerator and the white wire attached to the four pin power connector. Use at least #14 AWG white solid copper wire. Strip off the insulation jacket  $\frac{7}{16}$ " from the end of each insulated wire lead. Twist the three stripped leads together and secure the connection with a yellow wire nut connector.
4. Install a grounding conductor from the ground lug in the main service panel to the control center. This wire, along with the non-insulated ground lead in the aerator underground electrical cable, must be connected to the green wire attached to the four pin power connector. Strip off the insulation jacket  $\frac{7}{16}$ " from the end of the insulated wire lead. Twist the three ground leads

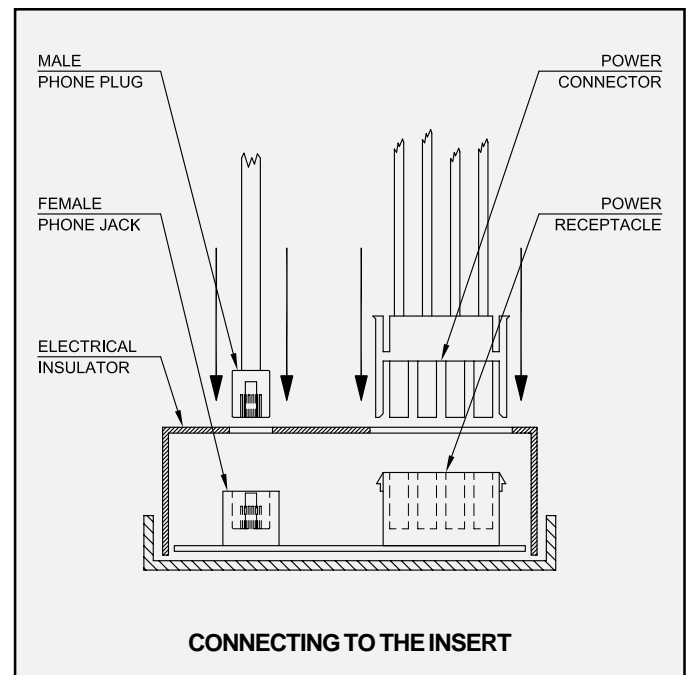

**MANUFACTURED BY**

***norweco***<sup>®</sup>

*Engineering the future of water and wastewater treatment*

**NORWECO, INC.**  
**NORWALK, OHIO**  
**U.S.A. 44857**  
**www.norweco.com**

# SERVICE PRO®

## CONTROL CENTER WITH MCD TECHNOLOGY

### INSTALLATION AND OPERATION (Page 3 of 6)

on the power connector pin attached to the red lead and one probe on the power connector pin attached to the white lead. The meter should read 0 volts. Once these readings are confirmed, place the dedicated circuit breaker in the main service panel in the “off” position. The conduit openings in the control center must now be sealed using duct seal. **IMPORTANT:** The conduit openings must be sealed to prevent corrosive gas from entering the control center enclosure and causing a fire or explosion. Failure to properly seal all conduit openings will void the Singulair system warranty.

9. Close the insulator and plug the four pin power connector into the control center insert until the latches are secure. Snap the insert into position.
10. When the auxiliary inputs are used, label the corresponding alarm light located on the front of the Service Pro control center insert using the labels provided.

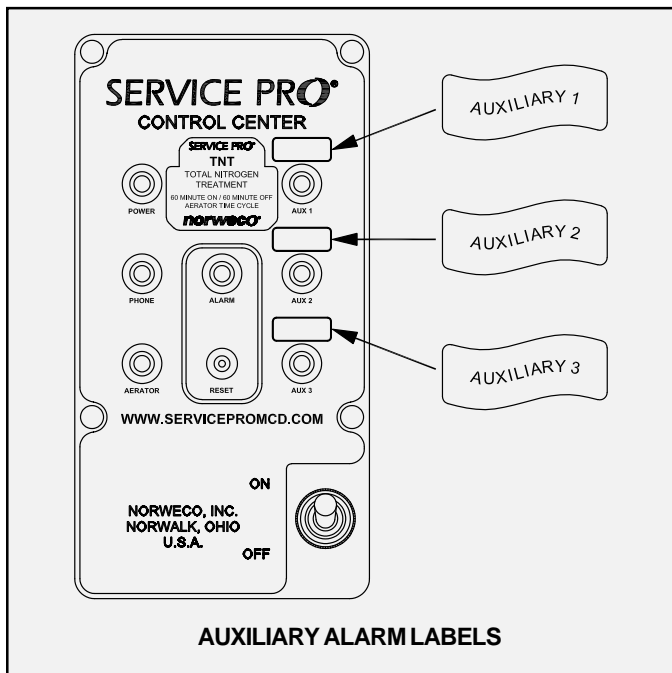

11. Clearly label the dedicated circuit used for each Singulair aerator on the door of the main service panel. Replace the service panel dead front and enclosure cover.
12. Make sure the selector switch in the control center is in the “off” position.
13. Complete the steps outlined in the “Before Leaving” section of the Electrical Wiring and Control Center Installation instructions.

#### AUXILIARY ALARM INPUTS

The Service Pro control center will accept alarm inputs that generate four different types of output: a 115 volt AC signal, a 5 to 24 volt AC or DC signal, a normally open relay circuit

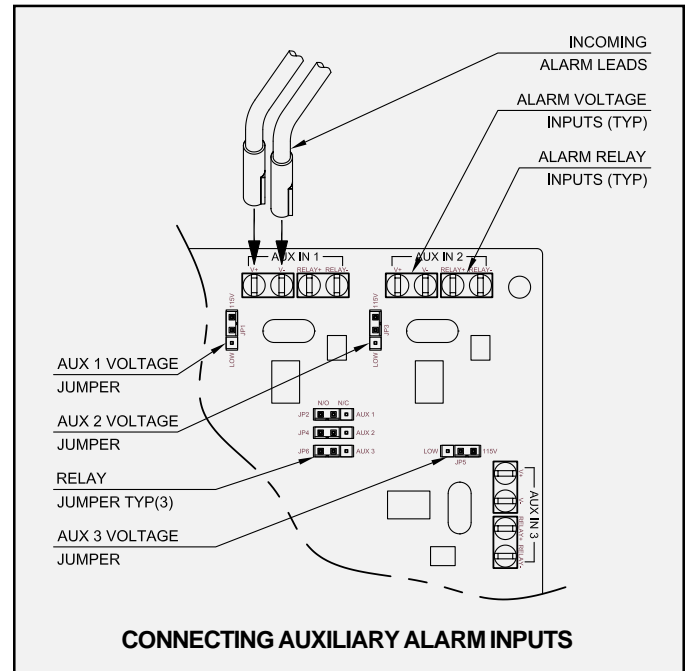

or a normally closed relay circuit. The inputs on the control center are male 0.110" quick connect terminals and accept standard female 0.110" insulated quick connect receptacles.

When connecting to the three auxiliary alarm inputs:

1. Determine the type of output that is generated by the alarm device you wish to connect.
2. Route the leads through one of the electrical conduit knock outs in the bottom of the enclosure. Be sure to pull enough wire to comfortably reach the two auxiliary terminals you will be connecting to on the back of the control center insert.
3. Crimp the insulated female 0.110" quick connect receptacles to the ends of the alarm leads.
4. Connect the leads to the corresponding auxiliary alarm inputs. When connecting a relay circuit, connect to the “RELAY +” and “RELAY -” terminals. For a high or low voltage input, connect the leads to the auxiliary alarm terminal marked “V+” and “V-”.
5. When connecting a device that uses a voltage output, you will need to adjust the voltage jumper for the correct voltage level. For high voltages (115V) set the jumper over the two poles closest to the 115V label. For low voltages, set the jumper over the two poles closest to the LOW label.
6. When connecting a device that uses a relay contact setting, you will need to set the relay jumper for the correct relay orientation. If the alarm circuit is normally closed, place the jumper over the two jumper terminals closest to the N/C label. If the alarm circuit is normally open, place the jumper over the two jumper terminals

# SERVICE PRO® CONTROL CENTER INSTRUCTIONS (Page 4 of 6)

closest to the N/O label (see CONNECTING AUXILIARY ALARM INPUTS on Page 3 for reference).

## TELEPHONE LINE INSTALLATION REQUIREMENTS

In order to utilize the telemetry system, a telephone cable must be installed between the control center and the telephone service box. This cable must be unspliced from the telephone box to the control center enclosure. Telecommunication systems and equipment used to supply service vary. Before installing the telephone wire, familiarize yourself with the equipment and policies of the local telephone service provider. The Service Pro control center is compatible with digital telephone service as long as it is installed downstream of the digital /analog converter. The following steps must be performed to complete system wiring. If a telephone cable is not available, one will need to be installed using the connector and methods specified by the telephone service provider.

1. Make sure the dedicated circuit breaker in the main service panel is in the "off" position. Using the grommet provided, run the telephone cable into the bottom of the control center enclosure.
2. Remove the insert and insert the telephone plug through the opening in the electrical insulator on the control center insert and plug into the female phone jack provided. Connect the other end of the phone line to the existing telephone system.
3. Snap the control center insert into position. Close the control center cover and secure it with a Norweco tamper evident seal.

## SERVICE PRO REGISTRATION

Refer to the Getting Started Website Instructions for step by step instructions on registering a new installation on the Service Pro website. If you do not have access to the internet, fill in all information fields on the registration card that came with the control center and place the card in the mail after affixing proper postage. The information is necessary to register the Singulair system at [www.servicepromcd.com](http://www.servicepromcd.com). In the Notification Method field, indicate your preferences for notification should an alarm condition occur. Your choices are email, fax or telephone call (an additional fee applies for telephone notification). Return the registration form to Norweco, and the information will be entered into the monitoring center for you. You will then be provided with Service Pro website information, including a username and password. The username and password will allow access to the Service Pro website in order to view all operating information on each Service Pro control center installation.

## RESET BUTTON

The reset button mounted in the insert of the control center is used to perform multiple tasks during installation and

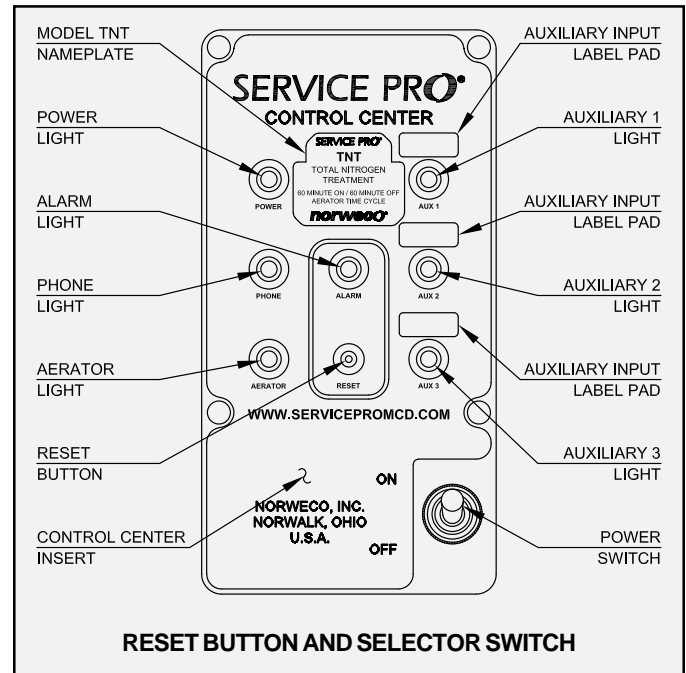

operation. The position of the reset button is fixed and it does not extend (pop out) in the event of an alarm condition. To activate the reset button, use your index finger to apply slight pressure. The button is actuated when a "click" is heard. The reset button can be used to silence the audible alarm, turn on the aerator when it is in an off cycle or to restart the run cycle when the aerator is currently running. The reset button can be used to test the control center audible and visual alarms and telemetry system. **NOTE:** Excessive pressure on the reset button should be avoided.

To test the alarms, press and hold the reset button for approximately five seconds until the audible and visual alarms activate, and then release the button. After five seconds, the dialer will call out and deliver an alarm test message to the Service Pro monitoring system. Once the call is complete, the control center will return to normal operation.

The reset button can also be used to record service visits. When arriving on site, press and hold the reset button for five seconds until the alarm test feature activates, then release the button. Once system service has been completed, press and hold the reset button again for five seconds until the alarm test feature activates. The Service Pro control center will register two alarm test calls received within a four hour period as a service visit. The date, time and duration of the service visit will be logged in the database for future reference.

**MANUFACTURED BY**

***norweco***<sup>®</sup>

*Engineering the future of water and wastewater treatment*

**NORWECO, INC.**  
**NORWALK, OHIO**  
**U.S.A. 44857**  
**[www.norweco.com](http://www.norweco.com)**

# SERVICE PRO®

## CONTROL CENTER WITH MCD TECHNOLOGY

# INSTALLATION AND OPERATION (Page 5 of 6)

### DIALER COMMISSIONING

Each control center is shipped with the integrated telemetry system disabled. All other monitoring, diagnostic and local alarm functions will operate as designed. The reset button is used to enable the integrated telemetry system when telephone service has been connected. This process is referred to as commissioning the dialer. Commissioning notifies the Service Pro monitoring center that the control center is functional and ready to transmit information.

To commission the dialer, insure the dedicated circuit breaker in the main service panel is in the "on" position and the telephone line is properly installed. Place the control center selector switch in the "off" position. While holding in the reset button, place the selector switch in the "on" position. Continue to hold the reset button for five seconds. Release the reset button and allow the telemetry system up to sixty seconds to call out and complete the commissioning process. The phone light will illuminate during the call out process.

If commissioning is successful, the alarm light will flash at a steady rate for a period of five seconds as verification. If

commissioning is unsuccessful, the alarm light will flash in a pattern of one to five short flashes followed by a long pause. The pattern will repeat every few seconds. If commissioning is not successful, refer to the table below for troubleshooting information.

### ALARM CONDITION OPERATING SEQUENCE

When the control center detects an over current or an under current alarm condition, the alarm light will activate and flash a code that specifies the alarm condition that was detected. If an under current or open motor condition is detected, the alarm light will flash two short flashes followed by one long flash. If a high water or over current condition is detected, the alarm light will flash steadily. If either an over current or an under current alarm condition is detected, the Singulair aerator is shut down and an automatic system restart sequence begins. With the alarm light flashing, the control center will automatically attempt to restart the aerator every five minutes for a period of two hours (24 restart attempts). The control center monitors motor current during each restart attempt. If the proper level of current is detected, the control center returns the aerator to normal operation and turns off the alarm light. Pressing the reset button while the alarm

ALARM LIGHT DIAGNOSTIC CODES	
CONDITION	LIGHT FLASH PATTERN
Successful commissioning	Flash evenly for 5 seconds and stop
Alarm test	
Service visit start	
Service visit end	
Phone line not plugged in	Flash 1 short, 1 long - pause 3 seconds & repeat
Phone line in use in home	Flash 2 short, 1 long - pause 3 seconds & repeat
Number called is busy	Flash 3 short, 1 long - pause 3 seconds & repeat
Remote monitoring center error	Flash 4 short, 1 long - pause 3 seconds & repeat
Service Pro panel error	Flash 5 short, 1 long - pause 3 seconds & repeat
Aerator under current	Flash 2 short - pause 3 seconds & repeat
Aerator open motor	Flash 2 short - pause 3 seconds
Aerator over current	Flash evenly until serviced
Auxiliary one	
Auxiliary two	
Auxiliary three	

# SERVICE PRO® CONTROL CENTER INSTRUCTIONS (Page 6 of 6)

light is flashing causes the control center to attempt to restart the aerator and counts toward the 24 restart attempts. If the aerator does not restart after 24 attempts, the audible alarm and the alarm light activate.

After both audible and visual alarms are activated, press the reset button and the control center will attempt to restart the aerator again. If the proper current level is not detected, the audible alarm beeps three times, then silences. The alarm light continues to flash and the control center interrupts power to the aerator. If the alarm condition is not corrected and the control center reset after 48 hours, the audible alarm will automatically reactivate.

If an auxiliary alarm condition is detected, the audible alarm and the corresponding auxiliary alarm light will activate.

If the telemetry system on the Service Pro control center has been commissioned, the system will then attempt to call out after a five minute delay and deliver an alarm message. The system will call the Service Pro monitoring center every 48 hours until the alarm condition is corrected and the control center is reset. The Service Pro control center uses advanced diagnostic technology to monitor the Singulair system for proper operation. In the event an alarm condition is encountered, the control center will display a series of flashes from the alarm light located in the center of the control panel (refer to the Alarm Light Diagnostic Codes chart on Page 5 for further reference).

## SYSTEM HEARTBEAT FEATURE

The Service Pro control center contains a system heartbeat feature that will call out every 30 days to inform the monitoring center that the Singulair system is functioning as designed. If the heartbeat call is not received, the monitoring center will notify the distributor or service provider that service is required at that location.

## FCC COMPLIANCE

This equipment complies with Part 68 of the FCC rules and the requirements adopted by the ACTA. The label on the inside of the control center cover contains, among other information, a product identifier in the format US:NK1MM00BLTS00700. If requested, this number must be provided to the telephone company.

If the Service Pro control center causes harm to the telephone network, the telephone company will notify you in advance that temporary discontinuance of service may be required. But if advance notice isn't practical, the telephone company will notify the customer as soon as possible. Also, you will be advised of your right to file a complaint with the FCC if you believe it is necessary.

The telephone company may make changes in its facilities, equipment, operations or procedures that could affect the

operations of the equipment. If this happens the telephone company will provide advance notice in order for you to make necessary modifications to maintain uninterrupted service.

If trouble is experienced with the Service Pro control center, for repair or warranty information, please contact Norweco, Inc. If the equipment is causing harm to the telephone network, the telephone company may request that you disconnect the equipment until the problem is resolved.

## SERVICE PRO WEBSITE

The telemetry system that comes standard with every Service Pro control center is engineered to interface with the Service Pro monitoring center. The Service Pro monitoring center allows the homeowner, service provider, licensed Norweco distributor and authorized regulatory entities access to Singulair wastewater treatment system records online. Records generated by the Service Pro control center throughout the life of the Singulair system (heartbeat record, alarm conditions, service records) can then be accessed at [www.servicepromcd.com](http://www.servicepromcd.com).

When a monitoring contract is initiated, the user will be issued a password that will allow them website access to the information pertaining to their system. Once a Service Pro control center has been installed and the homeowner has decided to use the Service Pro website, please refer to the Getting Started Website Instructions on how to proceed with setting up the user account. A control center can be commissioned either before or after the new account has been formally registered with the Service Pro monitoring center. However, if the commissioning step is performed first, the registration of the new account must be completed within thirty (30) days of commissioning. Additionally, the Service Pro monitoring service agreement must be signed and returned to Norweco before system monitoring will begin.

MANUFACTURED BY

***norweco***®

Engineering the future of water  
and wastewater treatment

**NORWECO, INC.  
NORWALK, OHIO  
U.S.A. 44857**

**[www.norweco.com](http://www.norweco.com)**



# *norweco*® SINGULAIR®

## INTEGRATED SYSTEM CONTROLS

# ELECTRICAL WIRING & CONTROL CENTER INSTALLATION

When Singulair wastewater treatment systems are installed in conjunction with pumped effluent disposal systems, the optional integrated system controls allow both aerator and pump operations to be managed from a single panel. Integrated system controls are available in simplex aerator/simplex pump, duplex aerators/simplex pump and duplex aerators/duplex pumps configurations to accommodate the corresponding aerator and effluent pump quantities required for the specific Singulair model being installed. These installation instructions should be followed for each individual aerator or pump associated with the Singulair system installation.

The information contained in these instructions is not intended to be a complete electrical installation reference, as code requirements vary according to geographic area. These instructions focus only on the specific requirements for the optional integrated system controls. They do not cover all installation aspects of the underground electrical cable and control center, preliminary inspection, testing and service of the control center or troubleshooting. Complete instructions are contained in the Bio-Kinetic Wastewater Treatment System Electrical Wiring and Control Center Installation yellow sheet. All electrical work must be performed in accordance with the latest edition of the National Electrical Code and all applicable local codes.

### UNDERGROUND ELECTRICAL CABLE INSTALLATION

1. A separate underground electrical service cable must be installed for each aerator within the Singulair system. Each cable must be UL or CSA approved, type UF, #14/2 AWG minimum and must have a full-size center ground. Larger cable is required if the underground service needs to be run more than 80 feet. A separate underground electrical service cable must also be installed for each effluent pump and float switch. Consult your electrician for details on pump and float cable sizing based on the specific pumps used and the length of the cable run. **NOTE:** Each float switch cable (other than alarm float switch cables) may carry the full electrical load of the pump and must be sized according to the same requirements as the pump power cord.
2. Each underground cable must be continuous and unspliced from the integrated control center to each aerator, pump and float switch.
3. Underground cable must be protected in conduit anytime the cable path passes directly across a tank or underground structure.
4. Uncoil the electrical service cables into the excavation influent sewer line trench. Extend the aerator cable to the aerator mounting casting and the pump and float electrical service cables to the pump station chamber. Leave sufficient slack in the cables so that they will not be stressed or pulled tight during backfill or settling.
5. All underground electrical cables should have at least two feet of earth cover. If the proposed finish grade will not permit at least two feet of earth coverage, all cables should be installed from the control center to the appropriate component using an approved conduit .

### INSTALLATION OF ELECTRICAL CONTROL CENTER

Although aerators and effluent pumps are not installed until the system is ready for start-up, the control center should be wired for operation when the tankage and underground electrical cables are installed. The integrated system controls should be located so that all warning lights can be readily seen and the audible alarm heard. The mounting location should minimize exposure to direct sunlight, freezing rain or conditions that might prevent routine inspection or access. The control center should always be mounted out of the reach of children.

Drill the appropriate openings in the bottom of each control center and install a conduit connector in each opening to be used. Exposed wiring to or from the control center should always be encased in conduit. Mount the control center securely using masonry nails, wood screws or common nails as appropriate.

1. Use a dedicated 115-volt AC single-phase circuit breaker in the main electrical panel for service to the integrated control center. The breaker must be sized according to the table on the next page. **CAUTION: Make sure that this breaker is de-energized. Check it with an electrical multi-meter before proceeding. Remember that other circuits in the service panel may remain energized as you are working. Use only tools with insulated handles, stand in a dry location and work with extreme care.**

# ELECTRICAL WIRING AND CONTROL CENTER INSTALLATION (Cont.)

## WIRE SIZING TABLE

Control Center Configuration	Main Circuit Breaker Size	AWG Wire Size	Maximum Wire Length*
Simplex aerator/simplex pump	20 amp	#10	75 feet

\*Where longer wire lengths are required, consult a local electrician for proper wire size.

2. Wire from a dedicated breaker in the main service panel to the terminal marked L1 (incoming power) in the integrated control center using copper wire with black insulation. The wire must be sized according to the table above.
3. Wire from the neutral in the main service panel to the incoming power terminal marked N in the integrated control center using copper wire with white insulation. The wire must be sized according to the table above.
4. Install a ground conductor (sized according to the table above) from the ground in the main service panel to the control center. This wire, along with the ground lead(s) of the underground electrical cables for the aerator(s) and pump(s), must be installed into the ground lug of the control center. **IMPORTANT:** Never allow the white neutral leads and ground leads to be spliced together or connected to common terminals.
5. Connect the underground electrical cable from each aerator, pump, float switch and optional chlorine alarm to the appropriate terminal in the integrated control center.
6. Inspect your work to make sure that there are no breaks in wiring insulation and that all connections are secure. Tighten all screws on the terminal board.
7. If the integrated control center is equipped with the optional telemetry system, a telephone line must be connected to the auto-dialer. A telephone line modular connector is located on the top of the dialer. Plug the incoming telephone line into the modular connector.
8. Carefully form all wiring neatly into the lower part of the Singulair control center. Do not allow the wires to make contact with other electrical components in the control center.
9. Seal all conduit openings with Duct Seal compound or similar appropriate material.
10. Replace the service panel dead front and enclosure cover. Clearly label the dedicated circuit breaker used for the integrated control center inside the door of the main service panel.
11. Place all selector switches and circuit breakers in

the Singulair control center in the "off" position. Close and secure the control center cover.

### ISC TANK MOUNT EQUIPMENT PACKAGE

The ISC tank mount equipment package simplifies the installation of Integrated System Controls that are mounted to the top of a Singulair tank or pump chamber. The electrical connections for the Singulair effluent pump, float switches, the optional ChemCheck Chemical Detection System and the optional telemetry system are all made inside a sealed, weatherproof enclosure.

Beneath the gasketed cover of the enclosure is a color-coded wiring harness that is connected to the ISC terminal strip. The color-coded leads of the wiring harness are matched to the leads from the effluent pump, float switches and the optional telemetry system during system installation. The 1 1/2" conduits that enter the control enclosure are sealed at the factory, preventing moisture and harmful gases from entering the enclosure and damaging ISC components. The tank mount equipment package protects the ISC, minimizes installation time and improves serviceability.

### BEFORE LEAVING

Complete all of the remaining steps outlined in Bio-Kinetic wastewater treatment system Electrical Wiring and Control Center Installation. Check to insure that all electrical controls, circuits and wiring for the Singulair system are de-energized. Be sure the red warning tag and distributor identification label are attached to the control center.

<b>MANUFACTURED BY</b>	
	<b>NORWECO, INC.</b> <b>NORWALK, OHIO</b> <b>U.S.A. 44857</b>
<i>Engineering the future of water and wastewater treatment</i>	

# ***norweco***® **SINGULAIR**®

## **BIO-KINETIC® WASTEWATER TREATMENT SYSTEM AERATOR INSTALLATION**

Installation of the aerator and Bio-Kinetic system should take place when the Singulair system is ready for start-up. Refer to the Bio-Kinetic System Installation instructions for additional details. Your delivery truck driver should have instructed the contractor or owner to contact your office and make arrangements for equipment installation to coincide with occupancy and sanitary sewer use. Review your Singulair tank setting records weekly to insure that you do not have equipment installations that are overdue. If you suspect that adequate time has passed for system start-up and you have not yet heard from the owners, contact them to schedule equipment installation. For Singulair Bio-Kinetic wastewater treatment systems requiring more than one aerator installation, follow these instructions for each aerator to be installed.

### **PRE-INSTALLATION CHECKLIST**

- ✓ The installer should have accurate directions to the facility and a list of service inspections due at other installations in the vicinity.
- ✓ The service vehicle should carry the Bio-Kinetic Tool Kaddy fully stocked with tools, spare parts and test equipment for use during installation.
- ✓ Someone should be present at the location to allow installer access to the control center and electrical service panel.
- ✓ The main electrical service panel wiring must be complete so each aerator may be started-up and tested.
- ✓ All chambers of the Singulair tankage should be full to the flow line.
- ✓ A Bio-Static sludge return should have been installed in each opening in the aeration/clarification chamber wall.
- ✓ The installer must have the proper model and quantity of aerators for the installation.
- ✓ The serial number on each aerator must match the service and warranty record card.

### **AERATOR START-UP PROCEDURE**

When you arrive on site, introduce yourself to the owner and ask to see the main electrical service panel and Singulair control center. Be certain each circuit for the Singulair system in the main electrical service panel is de-energized and that the selector switch in the Singulair control center is placed in the "off" position. Explain to the owner that you will be installing the aerator in the tank and you will need access to the main electrical service panel for system start-up after the aerator has been installed. Carry the aerator in its shipping carton to the tank site. Place the Singulair Bio-Kinetic Tool Kaddy nearby for easy access to tools and test equipment. Remove the vented cover from the aerator mounting casting. Carefully remove the aspirator shaft from the shipping carton. Do not bump or bend the aspirator shaft. Lay the shaft on the vented cover. Grip the outside bottom of the shipping carton with your feet and lift the aerator to remove it. Lay the aerator on its side with the brackets resting on the vented cover near the aerator mounting casting. Uncoil the underground electrical service cable from inside the aerator mounting casting and extend it out of the casting. Test the exposed leads with the electrical multi-meter from the Tool Kaddy before proceeding. The circuit should not be energized and voltage should not be evident when the leads are tested with the multi-meter.

### **WIRING THE ELECTRICAL CONNECTOR**

The moisture resistant electrical connector must be properly wired to insure system operation and protect components. Carefully follow these steps to completely wire the electrical connector:

1. Uncouple the two halves of the electrical connector on the Singulair aerator. Unscrew the three captive stainless steel screws from the face of the female half of the assembly. They will stay in the body of the receptacle. Lift out the rigid internal receptacle body.
2. Unscrew the compression nut on the strain relief connector assembly at the small end of the female half of the connector. Do not misplace the compression ring. Insert the electrical service cable through the compression nut, compression ring and neoprene grommet, which is contained in the molded plastic sleeve of the female connector.
3. Strip the outer insulation back 1 1/4" on the underground electrical service cable and expose the three individual leads. Use extreme care to be sure the insulation jackets on the individual black and white leads are not scarred or damaged while stripping the outer jacket. Check them carefully. If even slight damage is noticed, cut off the end of the cable just below your work and begin again.

## AERATOR INSTALLATION (Cont.)

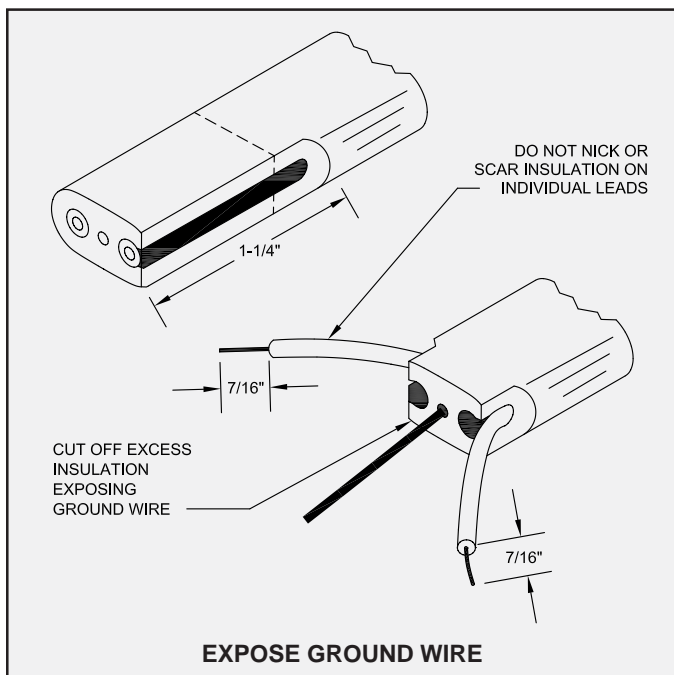

- Strip off the insulation jackets  $\frac{7}{16}$ " from the ends of the black and white leads.
- Insert the black lead end into the hole adjacent to the brass-colored screw and tighten the screw securely.
- Insert the white lead end into the hole adjacent to the silver-colored screw and tighten the screw securely.
- Insert the bare copper ground lead into the hole that is adjacent to the green colored screw and tighten the screw securely.
- Inspect your work to see that no two uninsulated leads are in contact with each other and that all screws are tight. Also be sure the wire insulation is not captured in the terminal. All power cable leads must be connected to the correct terminals in the female receptacle for proper aerator operation. The back of the insert body is clear, making it easy to verify that each wire is in place before tightening the terminal screws. Improper wiring or electrical hook-up will void the warranty.
- Locate the insert key above the grounding pole on the side of the rigid receptacle body and align it with the keyway molded on the inside of the rubber receptacle sleeve. Grasp the connector and insert the receptacle body fully into the sleeve.
- Engage the three captive stainless steel screws on the face of the receptacle body and tighten them.
- Press the neoprene grommet onto the small end of the female half of the electrical connector. Tighten the compression nut and clear plastic compression ring against the grommet. The compression nut achieves maximum torque by hand-tightening. Do not over-tighten the compression nut.

**NOTE:** Any time the female connector is not in use, secure the closure cap in the end of the receptacle.

### ASPIRATOR SHAFT INSTALLATION

Each Singulair aerator is manufactured and tested to a critical straightness tolerance from the aerator motor to the aspirator. Remember that the operating life of the aerator often depends on the straightness of the aspirator shaft. It must not be bumped or allowed to contact anything except the aeration tank liquid.

- With the Singulair aerator lying on its side and the brackets propped up on the vented cover, rotate the foam restrictor until the stainless steel set screws in the intermediate shaft are facing up.
- Loosen the two set screws that are located closest to the foam restrictor.
- Examine the upper end of the aspirator shaft and locate the alignment mark permanently affixed during factory testing. Insert the aspirator shaft into the intermediate shaft so that the alignment mark on the aspirator shaft meets the corresponding mark on the intermediate shaft. Be sure both set screws have been loosened before inserting the aspirator shaft. The aspirator shaft must be fully inserted to the depth of the stop shoulder that has been machined in the outside of the aspirator shaft. Use a tee-handle allen wrench to tighten both set screws finger tight only. Overtightening may dish the side of the aspirator shaft and compromise the straightness tolerance.

### INSTALLATION IN THE MOUNTING CASTING

- Lower the aerator into the aerator mounting casting carefully to avoid any contact between the aspirator shaft, aspirator tip and concrete side walls.
- Make sure that the weight of the aerator is evenly distributed on all four mounting brackets and that the brackets are seated in the four precast grooves on the top of the aerator mounting casting.
- Arrange the underground power cable in the mounting casting so that it does not touch or come into contact with the side of the Singulair aerator.
- Make sure the blades on the male half of the electrical connector are clean and dry. Plug the two halves of the watertight electrical connector together making sure the multiple lip seal is securely engaged. Arrange the aerator power cord, electrical connector and underground electrical cable around the aerator, and secure them into the mounting clips attached to the aerator upper brackets. Before replacing the aerator mounting casting lid, make sure these electrical connections are not resting against the top of the aerator.

MANUFACTURED BY

**norweco**<sup>®</sup>

*Engineering the future of water  
and wastewater treatment*

**NORWECO, INC.**  
**NORWALK, OHIO**  
**U.S.A. 44857**

**www.norweco.com**

# *norweco*® SINGULAIR®

## BIO-KINETIC® WASTEWATER TREATMENT SYSTEM USING THE UNIVERSAL TOOL

The universal tool is available to assist in the installation and service of the Bio-Kinetic system. This device incorporates a swab tool, locking lug tool, lifting tool and disassembly tool into one convenient package. The swab tool simplifies the application of Bio-Kinetic lubricant to the outlet components of the Singulair tank. The locking lug tool engages and disengages the locking lugs of the Bio-Kinetic system beneath the concrete lip of the mounting casting. The lifting tool assists in the installation and removal of the Bio-Kinetic system from the Singulair tank. The disassembly tool allows the inner components of the Bio-Kinetic system to be removed and reinstalled without removing the entire assembly.

### USING THE SWAB TOOL

The swab tool is used to apply Bio-Kinetic lubricant to the rubber and plastic outlet connection components. Proper lubrication will insure the outlet connection engages easily without leaks. To prepare the swab tool for use, place a clean cloth through the eyelet of the swab tool and apply Bio-Kinetic lubricant to the cloth.

Examine the receiving flange cast into the outlet of the Singulair tank. The grooves and face of the receiving flange should be free from debris. Using the swab tool, apply a liberal amount of Bio-Kinetic lubricant to the grooves and face of the receiving flange. Locate the gasketed discharge flange assembly installed in the outlet of the Bio-Kinetic system. Remove any debris from the gasket with a clean cloth. Lubricate the gasket using the swab tool.

**CAUTION:** Bio-Kinetic lubricant has been specially formulated. Use of other lubricants, especially petroleum based lubricants, can cause degradation of the rubber components and will void the warranty.

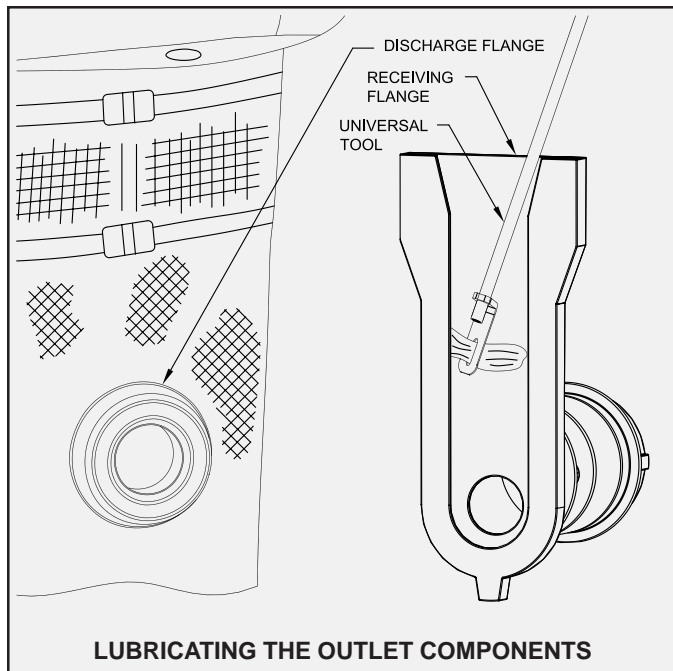

LUBRICATING THE OUTLET COMPONENTS

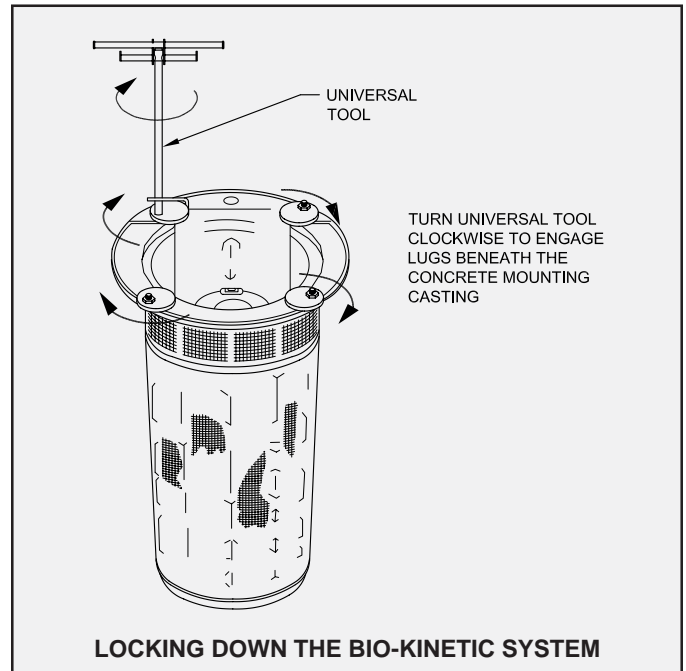

LOCKING DOWN THE BIO-KINETIC SYSTEM

### USING THE LOCKING LUG TOOL

The locking lug tool engages and disengages the locking lugs beneath the concrete lip of the mounting casting. When locked into position, the locking lugs hold the Bio-Kinetic system in place. The locking lugs must be disengaged to allow the Bio-Kinetic system to be removed from the Singulair tank for service.

To engage or disengage the locking lugs, remove the clarification chamber access cover and place it upside down next to the mounting casting. Remove the service cover from the Bio-Kinetic system. Place the locking lug tool, located opposite the fixed handle, over one of the locking lug bolts of the Bio-Kinetic system. Turn the locking lug tool clockwise to engage or disengage lugs beneath the concrete lip of the mounting casting.

# USING THE UNIVERSAL TOOL (Cont.)

## USING THE LIFTING TOOL

The lifting tool assists in the installation and removal of the Bio-Kinetic system from the Singlair tank. The Bio-Kinetic system will need to be removed from the clarification chamber periodically for cleaning and service.

To remove the Bio-Kinetic system, remove the clarification chamber access cover and place it upside down on the ground near the mounting casting. Remove the service cover from the Bio-Kinetic system. Follow the instructions on the previous page to disengage the locking lugs.

The universal tool is equipped with a fixed handle and a movable handle. Lower the fixed handle into the open top of the Bio-Kinetic system. The fixed handle of the lifting tool should be aligned with two opposing locking lugs to allow the tool to drop into the lifting rib on the Bio-Kinetic system. Insert the end of the fixed handle that is opposite the flat area on the Bio-Kinetic system into the lifting rib. Lower the other end of the fixed handle down by the side of the flat area and into the lifting rib. Turn the handle until the lifting tool is engaged into the lifting rib. Guide the Bio-Kinetic system out of the mounting casting as it is being dewatered. Once completely dewatered, remove the Bio-Kinetic system from the mounting casting.

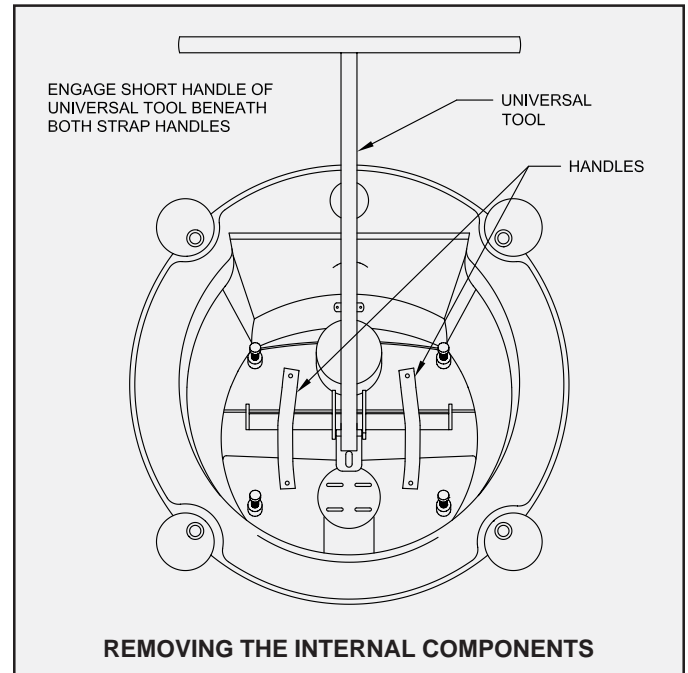

## USING THE DISASSEMBLY TOOL

The disassembly tool allows the deck plates, flow deck, and inner baffle of the Bio-Kinetic system to be removed for service without removing the entire system from the clarification chamber. It is not necessary to dewater the Bio-Kinetic system before removing the internal components.

To remove the internal components, remove the Bio-Kinetic system access cover and place it upside down on the ground near the mounting casting. Remove the service cover from the Bio-Kinetic system. Do not disengage the locking lugs.

The universal tool is equipped with a fixed handle and a movable handle. Lower the movable handle into the open top of the Bio-Kinetic system. The movable handle of the disassembly tool should be positioned so that each end of the movable handle is beneath the plastic handles on top of the flow deck. Lift the internal components with the disassembly tool to remove them from the Bio-Kinetic system. When service has been completed, use the disassembly tool to lower the internal components back into the Bio-Kinetic system.

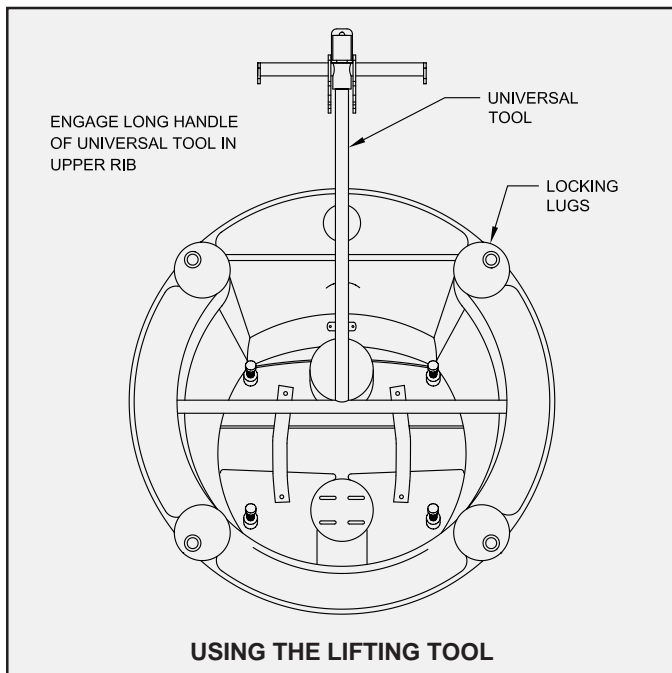

PROGRESS THROUGH

**norweco**  
www.norweco.com

SERVICE SINCE 1906

# ***norweco***® **SINGULAIR**®

## **BIO-KINETIC® WASTEWATER TREATMENT SYSTEM**

### **INSTALLATION OF THE BIO-KINETIC® SYSTEM**

The Bio-Kinetic system is installed in the final clarification chamber of the Singulair tank. This unique device accomplishes tertiary treatment and flow equalization in one compact assembly for any application where extremely high quality effluent is desirable. Installation of the Bio-Kinetic system can take place as soon as the tank is ready for storage or immediately after the tank is installed in a prepared excavation.

Drain and fill valves built into the Bio-Kinetic system allow it to be installed within the Singulair tank any time after the tank has been poured and stripped. This allows faster Singulair system installation and less time at the installation site. When installing the Bio-Kinetic system before tank delivery, make sure the tank is stored in a level position to avoid stress on the cast-in-place receiving flange, the Bio-Kinetic discharge flange or to prevent damage to the outer chamber filter media.

#### **BIO-KINETIC® SYSTEM PRE-INSTALLATION CHECKLIST**

- ✓ All chambers of the Singulair tank should be full to the flow line with clean hold down water as soon as the tank is placed in the excavation and backfilling begins. When the owner calls for start-up, ask him to check the liquid level in the Singulair system. If the liquid level has not reached the outlet invert, have the owner add clean water until full.
- ✓ These instructions consider the use of concrete as well as plastic risers and lids. The Bio-Kinetic system access opening pan, designed to accommodate the locking lugs into the tank top, must be used when installing plastic risers over the clarification chamber access opening.

#### **PREPARING THE SINGULAIR TANK**

1. Bio-Kinetic system mounting castings or plastic risers should be used for access to the clarification chamber. Additional riser castings or plastic risers may be added as necessary to reach finished grade.
2. When a mounting casting is used, it must be carefully sealed to allow the locking lugs of the Bio-Kinetic system to engage into the groove created when the mounting casting is installed on the tank top. Excess sealant in this groove may prevent the locking lugs from properly engaging. Other sealing procedures for the tank, mounting castings and risers are detailed in Singulair Tank Delivery and Setting instructions.
3. When plastic risers and lids are used to replace the concrete system mounting castings, make sure that the proper access opening pan has been used to create the grooves that are necessary for securing the locking lugs. Seal and secure the plastic risers to the manufacturer's specifications.
4. The Bio-Kinetic system should only be installed in a concrete mounting casting or plastic riser with a non-vented concrete or plastic cover above it. Do not seal the cover to the mounting casting or plastic riser. All mounting castings, risers and covers must be in place before backfilling the tank to prevent fill material from entering the Singulair tank.
5. The proper quantity of Bio-Static sludge returns should have been installed in the aeration/clarification chamber wall when tank delivery and setting was completed. Check to be sure that a Bio-Static sludge return is installed in each of the cast-in opening(s) in

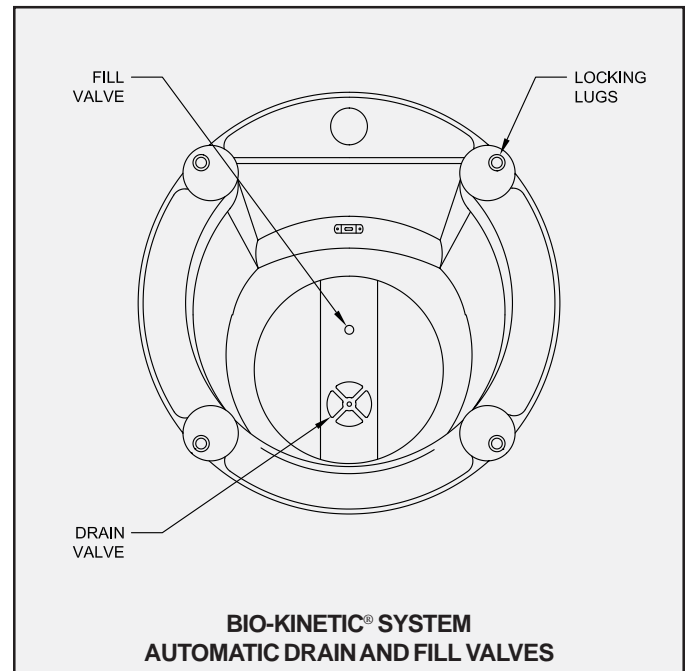

6. the aeration/clarification chamber wall.
6. If the Singulair tank is in an excavation, it should already be filled with clean water. The water should be free of dirt, mud, leaves, grit, oils or other materials that might possibly interfere with operation of the system. The tank should be filled with water inside, at the same time it is backfilled outside, to reduce stress on the precast tank. The aeration and clarification chambers will both be filled if the hose is installed in the aeration chamber access opening. The pretreatment chamber should be filled separately through its access opening.

## INSTALLATION THE OF BIO-KINETIC® SYSTEM (Cont.)

- Influent and effluent sewer lines must be installed and connected to the system as soon as it is set and before backfilling to prevent entry of mud or debris.
- When a Singular system is being installed to replace a failed onsite wastewater treatment system, the old septic tank need not be abandoned. However, be sure the Singulair system is installed downstream of the old septic tank and that the entire obsolete system is completely pumped and cleaned before the Singulair tank is installed. If the owner prefers, the obsolete system may be totally removed or filled in and abandoned in the ground.
- Check to see that roofing down spouts, footer drains, sump pump piping or garage and basement floor drains are not connected to the sanitary sewer. The Singulair system may not operate properly if hydraulic flows greatly exceed the rated treatment capacity. If the facility is equipped with a water softener, locate the backwash discharge line. The backwash line must not be connected to the Singulair system.

### BIO-KINETIC SYSTEM INSTALLATION PROCEDURE

Remove the Bio-Kinetic system from the shipping carton. Lift off the Bio-Kinetic system service cover and set it aside. Use the disassembly tool to remove the internal components and discard the shipping sleeve. Reinstall the internal components. Rotate the round, black locking lugs inward to allow installation.

The Bio-Kinetic system discharge flange must engage the plastic receiving flange that has been cast into the outlet of the Singulair tank. Carefully examine the condition of the outlet coupling and receiving flange. Any concrete residue or aggregate that has accumulated in the grooves of the receiving flange or inside of the outlet coupling must be removed and the grooves and face of the receiving flange should be wiped clean. Use the swab tool to apply a liberal amount of Bio-Kinetic lubricant to the entire face of the receiving flange and the inside of the grooves. Apply the lubricant evenly until all interior surfaces of the receiving flange and the grooves are thoroughly coated. Locate the gasketed discharge flange assembly installed in the outlet of the Bio-Kinetic system. Check to make sure that the assembly is tight and fully engages the discharge opening of the Bio-Kinetic system. Using the swab tool, apply a liberal amount of lubricant to the exterior surfaces of the gasketed discharge flange. Apply the lubricant evenly over the entire face of both sides and along the edges of the discharge flange.

**CAUTION:** Bio-Kinetic lubricant has been specially formulated. Use of other lubricants, especially petroleum based lubricants, can cause degradation of the rubber components and will void the warranty.

### SELF FILL VALVE

Use the lifting tool to lower the Bio-Kinetic system into the mounting casting. Be careful to align the discharge flange with the receiving flange that is cast into the tank. The Bio-Kinetic system is equipped with a pressure sensitive valve to aid in the filling process for new systems that are not yet filled and the draining process during service or removal. The fill valve is engineered to open when the pressure outside the Bio-Kinetic system reaches 16 inches of head. When the tank water level reaches 16 inches on the outer chamber of an empty Bio-Kinetic system, the fill valve will open. The valve will remain open until the water level inside

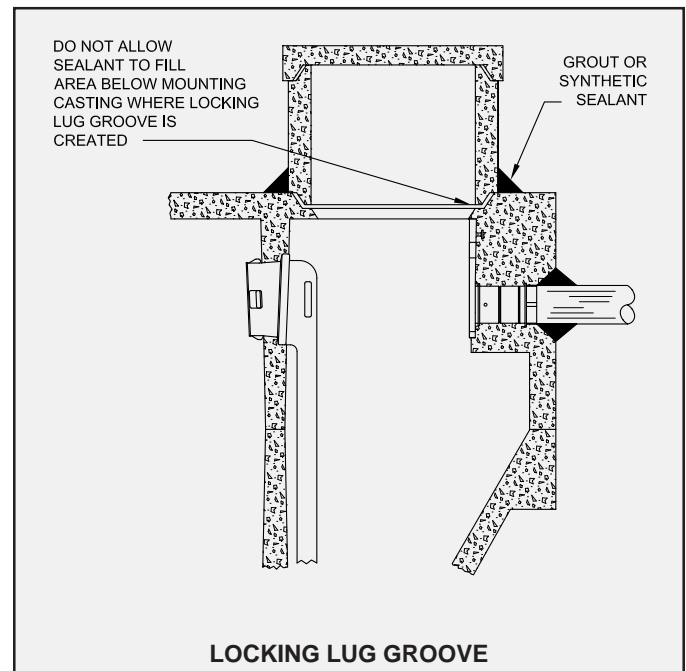

the filter reaches 4 inches below the water level outside the filter. At this point, the valve will close. For operation instructions on the drain valve system, refer to "Clarification Chamber and Bio-Kinetic Service." Carefully guide the system through the center of the opening using the lifting tool. Be sure to maintain the Bio-Kinetic system in a vertical position. If allowed to tilt, the system could rub the edge of the concrete opening and be damaged. **NOTE:** Use the viewing port to be sure proper alignment and engagement of the outlet connection takes place. The discharge flange must engage the top of the cast in place receiving flange.

Continue to lower the system until the discharge flange fully engages the receiving flange and the top collar of the

MANUFACTURED BY

**norweco**®

Engineering the future of water  
and wastewater treatment

**NORWECO, INC.**  
NORWALK, OHIO  
U.S.A. 44857

[www.norweco.com](http://www.norweco.com)



# SINGULAIR® BIO-KINETIC®

## WASTEWATER TREATMENT SYSTEM

### INSTALLATION OF THE BIO-KINETIC® SYSTEM (Cont.)

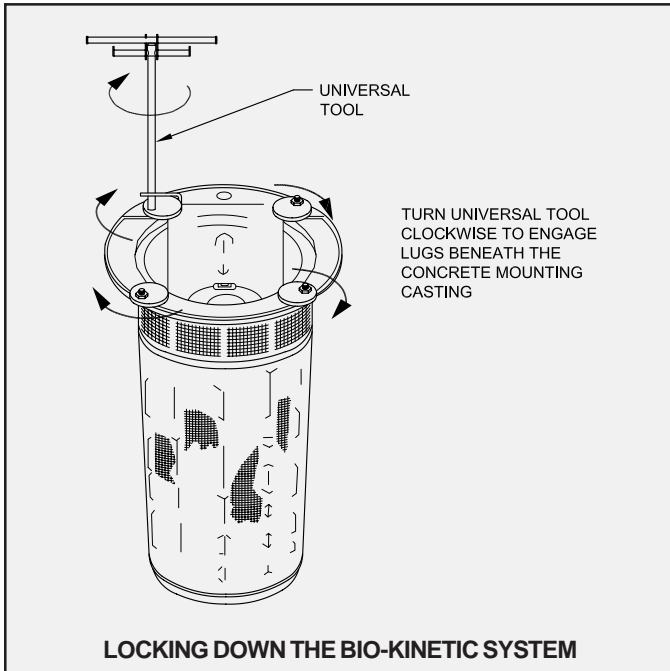

Bio-Kinetic system rests on the concrete ledge of the clarification chamber access opening. To confirm that the discharge flange and receiving flange are fully engaged, look through the viewing port in the top collar. Use the locking lug tool to twist each of the round, black locking lugs clockwise, so that each locking lug is positioned directly beneath the concrete lip of the mounting casting.

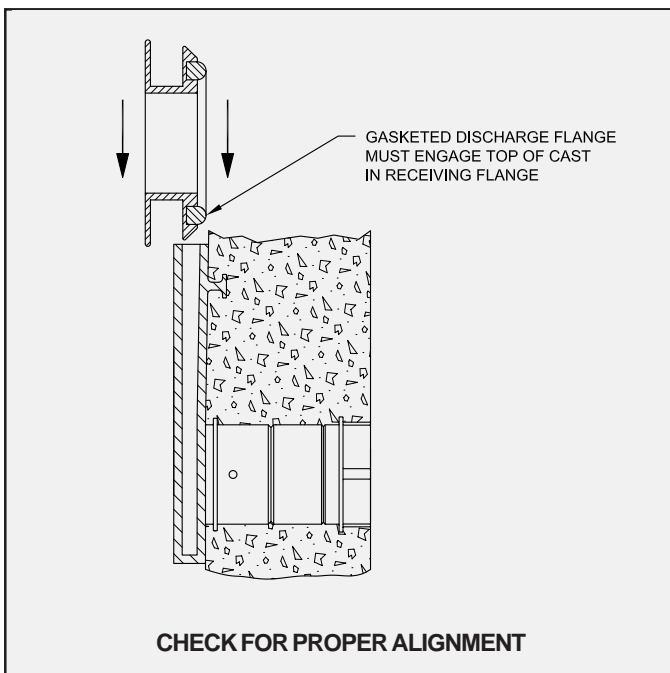

#### PLACING THE BIO-KINETIC SYSTEM ON LINE

Locate the level indicator mounted above the outlet of

the Bio-Kinetic system flow distribution deck. The bubble should be resting squarely between the two lines in the clear plastic case. If the location of the bubble indicates the system is not installed in a level position, the flow distribution deck should be leveled using the four adjustment lugs provided for this purpose. With the ratchet drive, extension and  $\frac{7}{16}$ " socket from the Tool Kaddy, turn each of the adjustment lugs the minimum amount necessary for the bubble to rest squarely between the two lines in the clear plastic case. Leveling of the flow distribution deck is essential for proper operation of the flow equalization ports and effluent weir within the Bio-Kinetic system. The system service cover can now be placed into position.

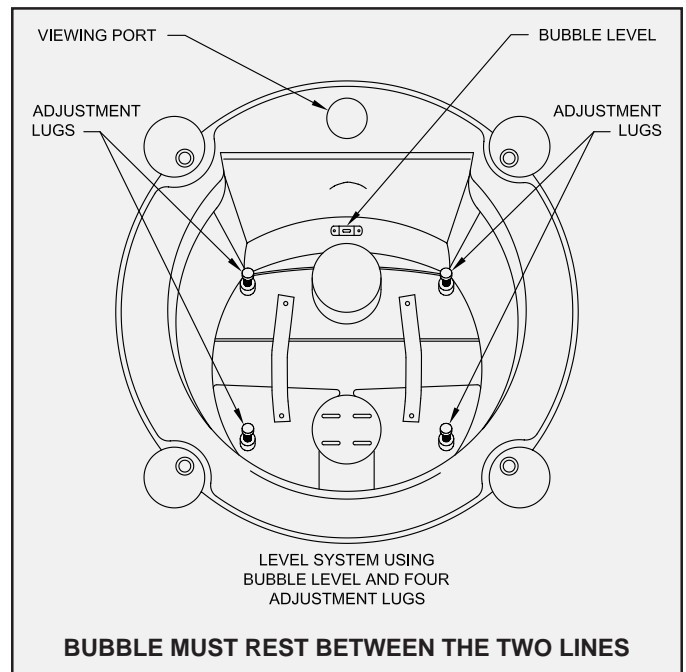

Install the cover, handle side up, aligning the four holes in the cover with the four locking lug bolts. The cover will come to rest on the collar of the Bio-Kinetic system. There is no need to add fasteners to the locking lug bolts.

#### SERVICING THE BIO-KINETIC SYSTEM

Each Singulair installation equipped with the Bio-Kinetic system should be inspected and serviced during each six-month prescheduled service inspection. Refer to the Bio-Kinetic System Service instructions for service procedures and recordkeeping policies.

MANUFACTURED BY

***norweco***®

Engineering the future of water  
and wastewater treatment

**NORWECO, INC.**  
**NORWALK, OHIO**  
**U.S.A. 44857**

**www.norweco.com**

# ***norweco***® **SINGULAIR**®

## BIO-KINETIC® WASTEWATER TREATMENT SYSTEM

### SINGULAIR® SYSTEM FINAL CHECK & SYSTEM START-UP

Immediately following installation of each Singulair aerator and Bio-Kinetic tertiary treatment device, the entire Singulair system should be given a final check and start-up. All tests should be performed to insure equipment is installed and operating properly. After all tests are satisfactorily completed, the selector switch in each control center should be set to the "automatic" position for electro-mechanical panels, or the "on" position for Service Pro control centers. Aerators should not be turned off, even during extended vacation periods. Some model Singulair systems require multiple aerators, control centers and Bio-Kinetic systems. Follow the instructions below for each aerator, control center and Bio-Kinetic system provided.

**CAUTION:** Any time an aerator or electrical test equipment is connected or disconnected, first shut off the selector switch in each control center. Failure to do so could result in personal injury or equipment damage.

#### PRELIMINARY ELECTRICAL INSPECTION

Inspect the control center for damage that might have occurred after its installation. Inspect all visible wiring to and from the control center. Report any damage to the owner at once; it must be corrected before proceeding with electrical testing.

Make sure the circuit breaker which supplies power to the Singulair system in the main electrical service panel is in the "off" position. Open the control center cover and place the selector switch in the "off" position. Proceed to the Singulair system and unplug the watertight electrical connector from the aerator power cord. Secure the closure cap in position on the electrical connector and return to the control center.

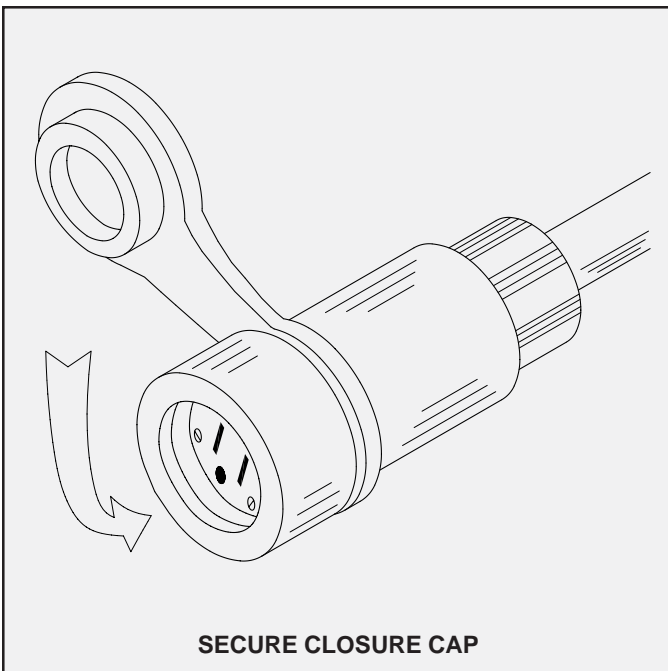

#### VOLTAGE TEST OF CONTROL CENTER

If the system is equipped with a Service Pro control center, unplug the power connector from the circuit board. For electromechanical control centers, remove the terminal strip insulator. Energize the circuit breaker in the main electrical service panel.

For Service Pro control centers, place one probe of the meter from the Tool Kaddy on the power connector terminal pin attached to the black wire and one probe on the pin attached to the white wire. It should read between 109 and 121 volts. Place one probe of the meter on the terminal pin connected to the red wire and one probe on the pin connected to the white wire. The meter should read zero volts.

For electromechanical control centers, place one probe of the meter on the terminal marked L1 and one probe on the terminal marked N. It should read between 109 and 121 volts. Place one probe of the meter on the terminal marked A1 and one probe on the terminal marked N. The meter should read zero volts. Once these readings are confirmed, place the selector switch in the "off" position, carefully reinstall the terminal strip insulator and proceed to the aerator.

#### VOLTAGE TEST OF AERATOR

Remove the polarity tester from the Tool Kaddy and insert it into the receptacle of the electrical connector. When the circuit is energized, the polarity tester should indicate proper wiring of the connector and control center. Remove the polarity tester and insert one probe of the multi-meter into each slot of the electrical connector. It should read between 109 and 121 volts. Do not energize the Singulair system if an electrical problem is found. Advise the owner and return only when the problem condition has been corrected by a qualified electrician.

# SINGULAIR® SYSTEM FINAL CHECK & SYSTEM START-UP (Cont.)

## AMPERAGE TEST

Remove the electrical test pigtail from the Tool Kaddy and place the current sensor of the multi-meter around the exposed black lead of the test pigtail. Plug the test pigtail in line between the two halves of the watertight electrical connector. When energized, read the current draw of the aerator. The initial reading should never be greater than 4.2 amps. After 48 hours of operation, break-in of the mechanical seals will allow the amp draw to drop to 3.8 amps or less. If an excessive current reading is obtained, de-energize the aerator immediately and do not re-energize it until the cause is found and corrected. When the test is complete, place the control center selector switch in the "off" position, unplug the test pigtail at both ends and plug the aerator directly into the receptacle on the underground electrical service cable. Make sure the two halves of the connector are firmly engaged to insure the integrity of the multiple lip seal for a moisture proof connection. Place the control center in "continuous" run operation.

## AERATOR INSPECTION

Check the aerator to make sure it is running smoothly without vibration. Make sure the four brackets are properly seated in the four cast-in grooves. Arrange the power cord assembly and electrical connector so they are secured in the mounting clips and are not touching the top of the aerator. Confirm that the debris screens are in place in the air intake ports. Replace the vented cover over the aerator mounting casting and check for excessive noise. Listen for evidence of debris in the aeration chamber striking the aspirator shaft. Occasionally, discarded construction materials may enter the sewer line and Singulair tank. They must be removed at once so that the aspirator shaft straightness tolerance is not compromised. Inspect the vent cap openings to assure the unrestricted passage of air.

## FINAL INSPECTION OF BIO-KINETIC SYSTEM

Remove the concrete cover from the clarification chamber access opening. Remove the Bio-Kinetic system service cover. Inspect the black locking lugs to make sure they are fully engaged beneath the concrete mounting casting. Inspect the level indicator to be sure that the Bio-Kinetic system is installed in a level position to insure proper operation. Replace the system service cover. Replace the concrete access cover.

## INSPECTION OF EFFLUENT DISPOSAL SYSTEM

Inspect the final discharge point to make sure that the outlet is unrestricted. If you suspect any possibility of a drainage problem, report it to the owner and request that corrective action be taken immediately. The system could be subjected to high water and liquid may back up into the inlet sewer line if not corrected. Locate the ground water

relief point and insure it is clean and unobstructed.

When an effluent lift pump or other accessory equipment has been installed as part of the Singulair system, these items must be started-up, and placed into operation at this time. Refer to the individual start-up instructions furnished with accessory equipment and test them accordingly.

## WHEN YOUR INSPECTIONS ARE COMPLETE

Place the selector switch in the Singulair control center in the "automatic" or "on" position, depending upon the model. Latch the control center cover and secure it with a tamper evident seal. Notify the owner that the Singulair system is operating properly. Ask if there are any questions regarding system operation. Most start-up problems are caused by improper or incomplete installation of the system or because of a misunderstanding on the part of the contractor or owner. Refer to the Singulair Trouble-Shooting guide for direction if a problem is discovered during start-up.

MANUFACTURED BY

***norweco***®

Engineering the future of water  
and wastewater treatment

**NORWECO, INC.  
NORWALK, OHIO  
U.S.A. 44857**

**[www.norweco.com](http://www.norweco.com)**

# ***norweco***® **SINGULAIR**®

## INTEGRATED SYSTEM CONTROLS

# SINGULAIR® SYSTEM FINAL CHECK & SYSTEM START-UP

When Singulair wastewater treatment systems are installed in conjunction with effluent disposal systems requiring pumping, the optional integrated system controls allow both aerator and pump operations to be controlled from a single panel. Based on the specific Singulair model number and the corresponding quantity of aerators and effluent pumps required, integrated system controls are available in simplex aerator/simplex pump, duplex aerators/simplex pump and duplex aerators/duplex pumps configurations. Optional features allow chemical level monitoring, failsafe pump control and telemetry.

These instructions are directed only to the specific requirements of the optional integrated system controls. They are not intended to cover all aspects of preliminary inspection of the Singulair system. Additional instructions are contained in Bio-Kinetic wastewater treatment system Singulair System Final Check and System Start-up.

### PRELIMINARY ELECTRICAL INSPECTION

**CAUTION:** Before initiating any electrical component inspection, turn off all power to the Singulair system and test for voltage with the electrical multi-meter from the Service Pro Tool Kaddy. Inspection and repairs should always be made by a qualified electrician using proper procedures and safe tools. Make sure all circuits are properly grounded. Do not stand in damp locations when making electrical system tests. Always use tools with insulated handles for electrical repairs. Inspect the Singulair integrated system controls for damage that may have occurred after its installation. Inspect all visible wiring to and from the control center. Report any damage to the owner at once. Any damage must be corrected before proceeding with electrical testing.

Make sure that the circuit breaker which supplies power to the Singulair system from the main electrical service panel is in the "off" position. Open the control center cover and make sure all circuit breakers and selector switches are in the "off" or "normal" position. Proceed to the Singulair system and unplug each watertight electrical connector. Secure the closure cap in position on each electrical connector and return to the control center.

### VOLTAGE TEST OF CONTROL CENTER

Energize the circuit breaker in the main electrical service panel, as well as all circuit breakers in the integrated system controls. If the control center is equipped with the optional failsafe pump control feature, the alarms may activate. If this occurs, place the ALARM SILENCE switch in the "silence" position. Remove the electrical multi-meter from the Tool Kaddy to test the voltage being supplied. Set up the meter to read AC voltage on the 0-150 volt scale. Place one probe of the meter on the terminal marked L1 and one probe on the adjacent terminal marked N. It should read between 109-121 volts. If it is within these limits, place one

probe of the multi-meter on one of the terminals marked A1 and one probe on the adjacent terminal marked N. The meter should read 0 volts. Repeat this step for all other terminals marked AERATOR POWER. If zero voltage is indicated at all terminals marked A1 or A2, move the control center selector switch to the "continuous" position and the ALARM SILENCE switch to the "normal" position. The meter should now read the same as the incoming voltage between each set of terminals marked AERATOR POWER. Check the voltage at all sets of terminals marked A1 or A2 and N. If the voltage reads the same as incoming voltage, move the control center selector switch to the "automatic" position. Rotate the aerator timer knob until voltage is read. The meter should now read the same as the incoming voltage between each set of terminals marked AERATOR POWER. Manually rotate the aerator timer knob approximately 1/2 turn until the meter reads 0 volts. Once these readings are confirmed for all sets of terminals marked AERATOR POWER, place the aerator selector switch in the "off" position.

### ALARM TESTING

Test the alarm functions by placing the SYSTEM TEST switch in the "alarm test" position. The audible alarm should sound and the warning lights should illuminate. Place the ALARM SILENCE switch in the "silence" position. The audible alarm should not sound, but the all warning lights should continue to illuminate. Return both the SYSTEM TEST and ALARM SILENCE switches to the "normal" position.

Place the control center selector switch in the "continuous" position. Test the yellow aerator alarm light by de-energizing the aerator circuit breaker. The yellow aerator alarm light should illuminate and the audible alarm will sound. Re-energize the aerator circuit breaker.

Check the pump tank to see that all floats are hanging down, which is the "off" position. Place one probe of the

## SINGULAIR® SYSTEM FINAL CHECK & SYSTEM START-UP (Cont.)

multi-meter on a terminal marked P1 and the other probe on the adjacent terminal marked N. The meter should read 0 volts. Repeat this step for all other terminals marked PUMP POWER. If zero voltage is indicated at all terminals marked PUMP POWER, be sure the trippers on the pump timer in the enabled (outboard) position are in alignment with the triangular indicator on the inner face of the timer unit. At the pump tank, raise the lowest float (in the case of a 3 float pump station, or the lowest two floats in the case of a 4 float pump station), and secure them in the vertically "up" position. Return to the control center and again check the voltage at the terminals marked PUMP POWER. One set of terminals in the simplex pump panel and one of the two sets of terminals in the duplex panel should now read the same as the incoming voltage. Rotate the pump timer dial clockwise until the trippers in the disabled (inboard) position are in alignment with the triangular indicator on the inner face of the timer unit. All sets of PUMP POWER terminals should now read zero volts. In the case of a duplex pump panel, rotate the pump timer dial clockwise until the trippers in the enabled (outboard) position are in alignment with the triangular indicator on the inner face of the timer unit. Again, check the voltage at the terminals marked PUMP POWER. The alternate set of terminals should now read the same as the incoming voltage.

Return to the pump tank, invert the alarm float and secure it in the vertically "up" position. The audible and red visual alarms should be activated. Invert the highest float to a vertically "up" position and secure it. Check the voltage at all sets of terminals marked PUMP POWER. The meter should now read the same as the incoming voltage at each set of terminals. Return all floats to their vertically "down" position. If the integrated control center is equipped with duplex pump controls, press reset. The audible alarm should stop sounding and the red warning light should go off.

Check to make sure the trippers on the pump timer are enabled only during the time required by local regulations. Turn the outer ring dial of the pump timer until the correct time of day is currently displayed opposite the triangular indicator on the inner ring of the timer. Place the aerator selector switch in the "off" position.

### OPTIONAL TELEMETRY SYSTEM

Systems equipped with the optional telemetry feature must be programmed prior to being placed into operation. Begin programming the auto-dialer by placing the power switch on the dialer in the "on" position. Press the MODE button to select the PROGRAM mode. "Program" should appear on the dialer display. Press all of the digits of the first number to be dialed. The display can be used to check accuracy, as it will display every number pressed. Momentarily press the MEMORY button after the entire phone number has been entered. Next, press the 1 key. This number is now stored in memory location 1. To program a phone number into memory location 2, enter all of the digits for the second

number to be dialed, momentarily press the MEMORY button, then press the 2 key. Repeat this process for memory locations 3 and 4, if desired.

Record an outgoing voice message that identifies the location of the Singulair system by locating the microphone in the lower right corner of the speaker. When recording a message, talk of a normal voice about 10 inches from the microphone. Place the unit in the PROGRAM mode by pressing the MODE button. Next, press the 1 button. To record, press and hold the VOICE button down to initiate the 16 second recording process. The word "Voice" will appear on the display during recording. The VOICE button must be pressed for the entire time of recording. When the VOICE button is released, the word "Voice" will disappear from the display indicating that the recording process is complete.

To test the telemetry system, first notify all individuals that the system is programmed to call. Next, place the SYSTEM TEST switch in the "alarm test" position. The audible and visual alarms should activate. The audible portion of the alarm may be disabled by placing the ALARM SILENCE switch in the "silence" position. The dialer system is equipped with a built in three minute delay. After three minutes, the display should read "Alarm On." Allow the system several minutes to dial out. Place the SYSTEM TEST switch back into the "normal" position. Press the MODE button on the dialer until the display reads "Operate." Call each number the dialer was programmed to call and verify that the recorded voice message was received.

MANUFACTURED BY

***norweco***®

Engineering the future of water  
and wastewater treatment

**NORWECO, INC.  
NORWALK, OHIO  
U.S.A. 44857**

# ***norweco*® SINGULAIR®**

## **INTEGRATED SYSTEM CONTROLS**

# **FINAL INSTRUCTIONS TO THE OWNER**

When Singulair wastewater treatment systems are installed in conjunction with effluent disposal systems requiring pumping, the optional integrated system controls allow both aerator and pump operations to be controlled from a single panel. Based on the specific Singulair model number, the corresponding quantity of aerators, and quantity of effluent pumps required, integrated system controls are available in simplex aerator/simplex pump, duplex aerators/simplex pump and duplex aerators/duplex pumps configurations.

These instructions are directed only to the specific requirements of the optional integrated system controls. They are not intended to cover all aspects of service of the control center or troubleshooting. Additional instructions are contained in Bio-Kinetic wastewater treatment system Final Instructions to the Owner and Aerator Troubleshooting.

### **CONTROL CENTER SERVICE**

**CAUTION:** If your visual inspection of the Singulair control center reveals a problem, be sure to shut off the appropriate circuit breaker in the main service panel, then test all circuits with the electrical multi-meter to be sure they are de-energized prior to proceeding.

Control center service should be performed during each service inspection and should follow all parameters outlined in the Singulair Service Manual.

**NOTE:** The performance of the Singulair Model TNT system has been tested and certified with the aerator(s) operating on a 60 minute on / 60 minute off time cycle.

1. If there is no evidence of an electrical problem, check the main service panel to see that the circuit breaker is in the "on" position.
2. Check to see that all circuit breakers within the integrated control center are in the "on" position.
3. Check the aerator selector switch in the Singulair integrated control center to make sure that it is set to "automatic" operation.
4. Check all alarm selector switches in the Singulair control center to see that all alarm functions are in the "normal" position.
5. Verify that your company's identification label is affixed to the Singulair control center and is legible. Replace the label if necessary.
6. Inspect wiring from the control center to the aerator(s) and pump(s) as far as it is visible, and notify the owner if you see any damaged areas.
7. As you leave, make sure that the Singulair control center is set for "automatic" operation for all aerators and pumps.

### **ELECTRICAL TROUBLESHOOTING**

**CAUTION:** Before initiating any electrical component

**inspection or repair, turn off all power to the Singulair system by switching off the dedicated circuit breaker in the main electrical service panel and then test with the electrical multi-meter. Repairs should always be made by a qualified electrician using proper procedures and safe tools. Make sure that all circuits are properly grounded. Do not stand in damp locations when making electrical system tests. Always use tools with insulated handles for electrical repairs.**

No electrical power from electrical service panel to control center

Follow instructions detailed in "Electrical Troubleshooting Section" of the Singulair Service Manual

No electrical power from control center to aerator

Follow instructions detailed in "Electrical Troubleshooting Section" of the Singulair Service Manual

No electrical power from control center to pump

Check to see that pump circuit breaker is in the "on" position.

Check to see that "on" float in pump station wet well is elevated to its "closed" position.

Check all wiring from control center to pump.

Aerator will not start

Follow instructions detailed in "Electrical Troubleshooting Section" of the Singulair Service Manual

Pump will not start

See instructions contained in Pump Operation and Maintenance Manual

Replace defective float

## FINAL OWNER INSTRUCTIONS (Cont.)

The owner should be advised to make the following periodic checks of the system to insure that it continues to operate at maximum performance levels:

1. The Singulair control center should be checked daily. If the red warning light is glowing and the audible alarm sounding, depress the reset button on the control center cover. The light should go off and the audible alarm should be silenced. If the alarms activate again, call the local distributor for service.
2. Check the fresh air openings in each vented cover monthly to make sure the passage of air into the Singulair tank has not been restricted.
3. Inspect the effluent discharge point and ground water relief point monthly to make sure there are no restrictions to the effluent flow.
4. Make sure the pretreatment chamber is inspected at least every three years. Have it pumped only when necessary. See Singulair Tank Pumping Instructions to determine when pretreatment chamber pumping is required.

### FOR BEST RESULTS

Be sure the owner understands the system's capabilities and purpose. Discuss the importance of the following items with the owner to maximize system performance.

#### *Always*

1. *Repair any leaking faucets or toilets promptly.*
2. *Discharge only biodegradable wastes into the system.*
3. *Divert down spouts and other surface water away from the system.*
4. *Keep mounting casting and riser covers accessible for service and inspection.*
5. *Consult your Norweco distributor before using enzymes, tank activators or similar additives.*
6. *Call your Norweco distributor if you have problems or questions.*

#### *Never*

1. *Connect roofing down spouts, footer drains, sump pump piping or garage and basement floor drains into the sewer line of the Singulair system.*
2. *Allow backwash liquid from a water softener to enter the system.*
3. *Dispose of items such as lint, cooking grease, scouring pads, diapers, sanitary napkins, cotton balls, cotton swabs, cleaning rags, dental floss, strings, cigarette filters, rubber or plastic products, paints and thinning agents, drain cleaners or other harsh chemicals in the domestic wastewater plumbing.*
4. *Dispose of disinfectants, pesticides, poisons or toxic materials down your drain.*
5. *Use the power supply to the aerator as a service receptacle for lawn and garden tools.*
6. *Interrupt power to the Singulair control center, even during extended periods of non-use. If you anticipate a long term vacancy, contact the local distributor for proper procedures.*

### BEFORE LEAVING THE SITE

Remind the owner that the limited Warranty Registration Card must be filled in and mailed as soon as possible. Explain that your company's telephone number is found on the Singulair control center. Offer to remove and return the Warranty Registration Card for the owner. Have them sign the card and return it to your office to be mailed to Norweco. As you leave, remind the owner to call your office if any questions arise.

MANUFACTURED BY

***norweco***<sup>®</sup>

Engineering the future of water  
and wastewater treatment

**NORWECO, INC.  
NORWALK, OHIO  
U.S.A. 44857**

**www.norweco.com**

# ***norweco***® **SINGULAIR**®

## **BIO-KINETIC® WASTEWATER TREATMENT SYSTEM**

### **FINAL INSTRUCTIONS TO THE OWNER**

When the initial start-up of the Singulair Bio-Kinetic system has been completed, take a few minutes to review the system and its operation with the owner. Although no owner maintenance is required, several precautions should be taken to insure maximum performance of the system. Emphasize the continued benefits and protection available through the two year limited warranty, prescheduled service inspections and fifty year aerator exchange program which have been included in the purchase of the Singulair system. These instructions, used with a review of the Owner's Manual, will give the owner a basic understanding of the Singulair Bio-Kinetic wastewater treatment system.

#### **PRESCHEDULED SERVICE INSPECTIONS**

During the two year limited warranty period, service inspections will be made on a semi-annual basis to insure proper system operation. Written reports on the condition of the equipment and quality of the effluent will automatically be made to the owner and to the local health department. Costs for travel and labor during this period are included in the purchase price of the Singulair system. If emergency service covered by the warranty is needed during the two year warranty period, it will also be provided at no additional owner expense.

#### **CONTINUOUS OWNER PROTECTION PROGRAM**

At the conclusion of the limited warranty period, continued service inspections may be made semi-annually under a Singulair Service Contract available from the licensed distributor for a reasonable charge. Written reports will continue to be made automatically. Costs for travel and labor during service inspections are at no additional charge and emergency service is guaranteed within forty-eight hours. The owner will automatically be mailed a service contract with a letter outlining the advantages of continuing service and a fee quotation before the limited warranty period is about to expire.

#### **NO OWNER MAINTENANCE**

No owner maintenance is required on the Singulair aerator, electrical controls or Bio-Kinetic tertiary treatment device. System operation and individual components will be thoroughly checked by the service technician during each routine service inspection. The aerator motor is factory lubricated for the life of the unit. The Singulair control center has no user-serviceable parts inside and is secured with a tamper evident seal. Disassembly of any component part will void the limited warranty. Instruct the owner to contact the local distributor with questions and service requests.



#### **TWO YEAR LIMITED WARRANTY**

The Singulair precast concrete tank, aerator, control center and Bio-Kinetic system are warranted to be free from defects in material and workmanship under normal use and service for a period of two years from the date of system installation, provided the customer completes and returns the Warranty Registration Card to the factory. Registration is important: if the card is not received, the warranty will be recognized in effect for two years from the date the aerator, control center and Bio-Kinetic system were shipped from the factory. To qualify for service under warranty, the owner must not disassemble any component part. The defective component must be returned to the factory by the local distributor. It may not be returned directly to Norweco by the owner. The warranty is limited to the replacement of defective parts and does not cover damage resulting from accident, abuse, improper installation, unauthorized disassembly, faulty wiring or failure to follow operating instructions.



## FINAL OWNER INSTRUCTIONS (Cont.)

The owner should be advised to make the following periodic checks of the system to insure that it continues to operate at maximum performance levels:

1. The Singulair control center should be checked daily. If the red warning light is glowing and the audible alarm sounding, depress the reset button on the control center cover. The light should go off and the audible alarm should be silenced. If the alarms activate again, call the local distributor for service.
2. Check the fresh air openings in each vented cover monthly to make sure the passage of air into the Singulair tank has not been restricted.
3. Inspect the effluent discharge point and ground water relief point monthly to make sure there are no restrictions to the effluent flow.
4. Make sure the pretreatment chamber is inspected at least every three years. Have it pumped only when necessary. See Singulair Tank Pumping Instructions to determine when pretreatment chamber pumping is required.

### FOR BEST RESULTS

Be sure the owner understands the system's capabilities and purpose. Discuss the importance of the following items with the owner to maximize system performance.

#### *Always*

1. *Repair any leaking faucets or toilets promptly.*
2. *Discharge only biodegradable wastes into the system.*
3. *Divert down spouts and other surface water away from the system.*
4. *Keep mounting casting and riser covers accessible for service and inspection.*
5. *Consult your Norweco distributor before using enzymes, tank activators or similar additives.*
6. *Call your Norweco distributor if you have problems or questions.*

#### *Never*

1. *Connect roofing down spouts, footer drains, sump pump piping or garage and basement floor drains into the sewer line of the Singulair system.*
2. *Allow backwash liquid from a water softener to enter the system.*
3. *Dispose of items such as lint, cooking grease, scouring pads, diapers, sanitary napkins, cotton balls, cotton swabs, cleaning rags, dental floss, strings, cigarette filters, rubber or plastic products, paints and thinning agents, drain cleaners, gasoline, motor oil or other harsh chemicals in the domestic wastewater plumbing.*
4. *Dispose of disinfectants, pesticides, poisons or toxic materials down your drain.*
5. *Use the power supply to the aerator as a service receptacle for lawn and garden tools.*
6. *Interrupt power to the Singulair control center, even during extended periods of non-use. If you anticipate a long term vacancy, contact the local distributor for proper procedures.*

### BEFORE LEAVING THE SITE

Remind the owner that the limited Warranty Registration Card must be filled in and mailed as soon as possible. Explain that your company's telephone number is found on the Singulair control center. Offer to remove and return the Warranty Registration Card for the owner. Have them sign the card and return it to your office to be mailed to Norweco. As you leave, remind the owner to call your office if any questions arise.

**PROGRESS THROUGH**

***norweco***<sup>®</sup>  
www.norweco.com

**SERVICE SINCE 1906**

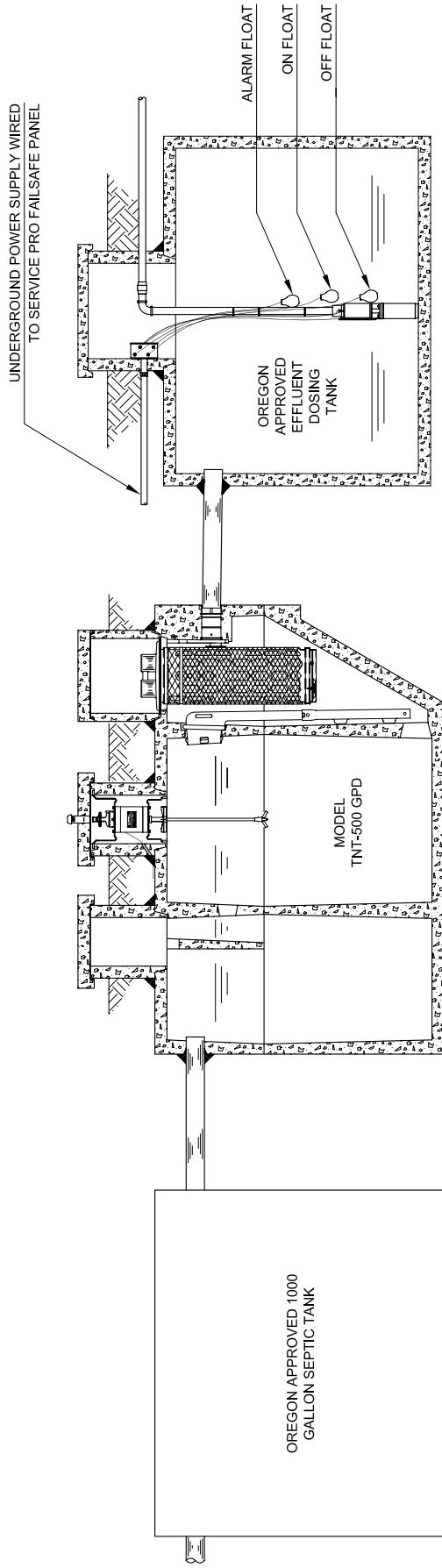

TREATMENT STANDARD #1 - PRESSURE DISTRIBUTION TO RECEIVING ENVIRONMENT

GENERAL NOTES:

1. FAILSAFE CONTROLS WILL SHUT DOWN EFFLUENT PUMP IF THERE IS A MALFUNCTION IN THE AERATOR OPERATION.
2. FAILSAFE CONTROLS WILL ALARM AND NOTIFY THE SERVICE PROVIDER IN THE EVENT OF A MALFUNCTION.
3. FAILSAFE CONTROLS WILL ALARM IF EFFLUENT LEVEL REACHES THE ALARM FLOAT.

PART NUMBER:		REVISED DATE	ISSUED DATE
		10-18-07	D
U.S. AND FOREIGN PATENTS PENDING		DESIGNED BY	BDS
		DRAWN BY	JMM
		DATE	8-29-07
		CHECKED BY	NTS
		DATE	PC-5-9935
		TREATMENT STANDARD #1 FLOW THROUGH SCHEMATICS	
<small>THIS DOCUMENT IS THE PROPERTY OF NORWECO. IT IS TO BE USED ONLY FOR THE PROJECT AND LOCATION SPECIFICALLY IDENTIFIED ON THE DRAWING. IT IS NOT TO BE REPRODUCED OR TRANSMITTED IN ANY FORM OR BY ANY MEANS, ELECTRONIC OR MECHANICAL, INCLUDING PHOTOCOPYING, RECORDING, OR BY ANY INFORMATION STORAGE AND RETRIEVAL SYSTEM.</small>			

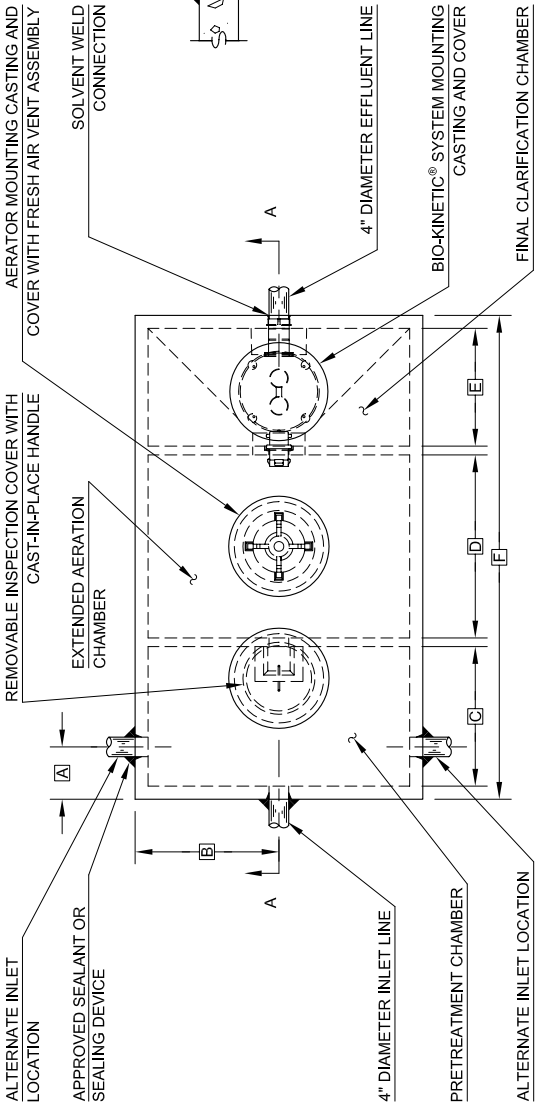

PLAN VIEW

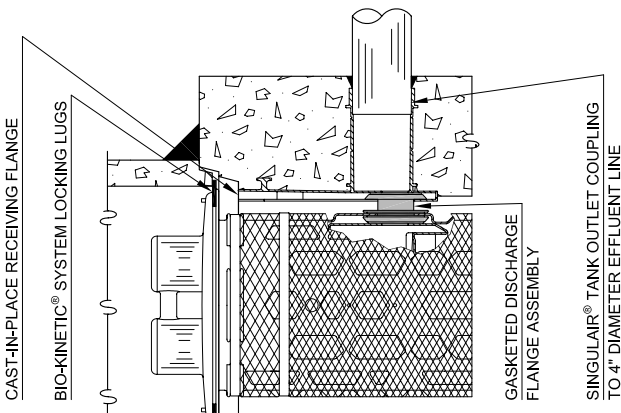

BIO-KINETIC® SYSTEM DISCHARGE DETAIL

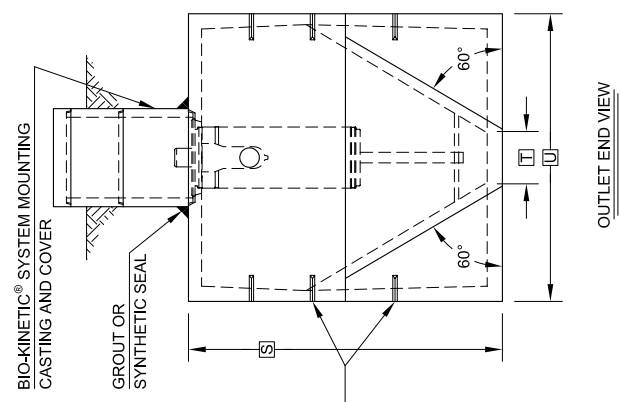

NOTE: TOTAL SYSTEM CAPACITY: 1,300 GALLONS  
 RATED CAPACITY: 500 GALLONS PER DAY

GENERAL NOTES:

- ① SINGULAIR® AERATOR, AS TESTED AND ACCEPTED BY NSF, OPERATING 60 MINUTES ON / 60 MINUTES OFF.
- ② FALL THROUGH SINGULAIR® PLANT FROM INLET INVERT TO OUTLET INVERT IS FOUR INCHES. INLET INVERT IS TWELVE INCHES BELOW TANK TOP.
- ③ ON DEEPER INSTALLATIONS, PRECAST RISERS MUST BE USED TO EXTEND AERATOR MOUNTING CASTING AND BIO-KINETIC® SYSTEM MOUNTING CASTING TO GRADE. INSPECTION COVER ON PRETREATMENT CHAMBER MUST BE DEVELOPED TO WITHIN TWELVE INCHES OF GRADE.
- ④ TANK REINFORCED PER ACI STD. 318.
- ⑤ REMOVABLE COVERS ON RISERS WEIGH IN EXCESS OF SEVENTY-FIVE POUNDS EACH TO PREVENT UNAUTHORIZED ACCESS.
- ⑥ CONTACT THE LOCAL, LICENSED SINGULAIR® DISTRIBUTOR FOR ELECTRICAL REQUIREMENTS.

PROJECT ENGINEER'S APPROVAL:  
 I (WE) HEREBY CERTIFY THAT THIS DRAWING HAS BEEN CHECKED AND IS APPROVED FOR USE IN CONFORMITY WITH THE CONTRACT DOCUMENTS.

DATE: \_\_\_\_\_

NAME: \_\_\_\_\_

CONTRACTOR'S CERTIFICATION:  
 I (WE) HEREBY CERTIFY THAT THIS DRAWING HAS BEEN CHECKED AND IS APPROVED FOR USE IN CONFORMITY WITH THE CONTRACT DOCUMENTS.

DATE: \_\_\_\_\_

NAME: \_\_\_\_\_

CRITICAL DIMENSIONS

A	1'-0"	N	0'-3"
B	2'-9"	O	0'-6"
C	2'-8"	P	0'-2 1/2"
D	3'-7"	Q	1'-4"
E	2'-3"	R	4'-8"
F	9'-3"	S	6'-0"
G	1'-0"	T	1'-0"
H	5'-0"	U	5'-6"
I	0'-3"	V	
J	0'-3"	W	
K	1'-0"	X	
L	0'-2"	Y	
M	4'-6"	Z	

U.S. AND FOREIGN PATENTS PENDING

**norweco**

SINGULAIR® BIO-KINETIC® WASTEWATER TREATMENT SYSTEM MODEL NT-800 GPD

REGISTERED COMPANY  
 BDS  
 APPROVED JMM  
 DATE 9-13-07  
 SHEET NTS  
 PROJECT PC-57105

**GENERAL NOTES:**

- ① SINGULAIR® AERATOR, AS TESTED AND ACCEPTED BY NSF, OPERATING 60 MINUTES ON / 60 MINUTES OFF.
- ② FALL THROUGH SINGULAIR® PLANT FROM INLET INVERT TO OUTLET INVERT IS FOUR INCHES. INLET INVERT IS TWELVE INCHES BELOW TANK TOP.
- ③ ON DEEPER INSTALLATIONS, PRECAST RISERS MUST BE USED TO EXTEND AERATOR MOUNTING CASTING AND BIO-KINETIC® SYSTEM MOUNTING CASTING TO GRADE.
- ④ TANK REINFORCED PER ACI STD. 318.
- ⑤ REMOVABLE COVERS ON RISERS WEIGH IN EXCESS OF SEVENTY-FIVE POUNDS EACH TO PREVENT UNAUTHORIZED ACCESS.
- ⑥ CONTACT THE LOCAL, LICENSED SINGULAIR® DISTRIBUTOR FOR ELECTRICAL REQUIREMENTS.

PROJECT ENGINEER'S APPROVAL:  
I (WE) HEREBY CERTIFY THAT THIS DRAWING HAS BEEN CHECKED AND IS APPROVED FOR USE IN CONFORMITY WITH THE CONTRACT DOCUMENTS.

DATE: \_\_\_\_\_

NAME: \_\_\_\_\_

CONTRACTOR'S CERTIFICATION:  
I (WE) HEREBY CERTIFY THAT THIS DRAWING HAS BEEN CHECKED AND IS APPROVED FOR USE IN CONFORMITY WITH THE CONTRACT DOCUMENTS.

DATE: \_\_\_\_\_

NAME: \_\_\_\_\_

**CRITICAL DIMENSIONS**

A	1'-0"	N	0'-3"
B	2'-9"	O	0'-6"
C	6'-2"	P	0'-2 1/2"
D	3'-7"	Q	1'-4"
E	2'-3"	R	4'-8"
F	12'-9"	S	6'-0"
G	1'-0"	T	1'-0"
H	5'-0"	U	5'-6"
I	0'-3"	V	
J	0'-3"	W	
K	1'-0"	X	
L	0'-2"	Y	
M	4'-6"	Z	

U.S. AND FOREIGN PATENTS PENDING

**norweco**

SINGULAIR® BIO-KINETIC® WASTEWATER TREATMENT SYSTEM MODEL TNT WITH 1000 GALLON PRETREATMENT CHAMBER

U.S. PATENT NO. 5,310,702

U.S. PATENT NO. 5,310,703

U.S. PATENT NO. 5,310,704

U.S. PATENT NO. 5,310,705

U.S. PATENT NO. 5,310,706

U.S. PATENT NO. 5,310,707

U.S. PATENT NO. 5,310,708

U.S. PATENT NO. 5,310,709

U.S. PATENT NO. 5,310,710

U.S. PATENT NO. 5,310,711

U.S. PATENT NO. 5,310,712

U.S. PATENT NO. 5,310,713

U.S. PATENT NO. 5,310,714

U.S. PATENT NO. 5,310,715

U.S. PATENT NO. 5,310,716

U.S. PATENT NO. 5,310,717

U.S. PATENT NO. 5,310,718

U.S. PATENT NO. 5,310,719

U.S. PATENT NO. 5,310,720

U.S. PATENT NO. 5,310,721

U.S. PATENT NO. 5,310,722

U.S. PATENT NO. 5,310,723

U.S. PATENT NO. 5,310,724

U.S. PATENT NO. 5,310,725

U.S. PATENT NO. 5,310,726

U.S. PATENT NO. 5,310,727

U.S. PATENT NO. 5,310,728

U.S. PATENT NO. 5,310,729

U.S. PATENT NO. 5,310,730

U.S. PATENT NO. 5,310,731

U.S. PATENT NO. 5,310,732

U.S. PATENT NO. 5,310,733

U.S. PATENT NO. 5,310,734

U.S. PATENT NO. 5,310,735

U.S. PATENT NO. 5,310,736

U.S. PATENT NO. 5,310,737

U.S. PATENT NO. 5,310,738

U.S. PATENT NO. 5,310,739

U.S. PATENT NO. 5,310,740

U.S. PATENT NO. 5,310,741

U.S. PATENT NO. 5,310,742

U.S. PATENT NO. 5,310,743

U.S. PATENT NO. 5,310,744

U.S. PATENT NO. 5,310,745

U.S. PATENT NO. 5,310,746

U.S. PATENT NO. 5,310,747

U.S. PATENT NO. 5,310,748

U.S. PATENT NO. 5,310,749

U.S. PATENT NO. 5,310,750

U.S. PATENT NO. 5,310,751

U.S. PATENT NO. 5,310,752

U.S. PATENT NO. 5,310,753

U.S. PATENT NO. 5,310,754

U.S. PATENT NO. 5,310,755

U.S. PATENT NO. 5,310,756

U.S. PATENT NO. 5,310,757

U.S. PATENT NO. 5,310,758

U.S. PATENT NO. 5,310,759

U.S. PATENT NO. 5,310,760

U.S. PATENT NO. 5,310,761

U.S. PATENT NO. 5,310,762

U.S. PATENT NO. 5,310,763

U.S. PATENT NO. 5,310,764

U.S. PATENT NO. 5,310,765

U.S. PATENT NO. 5,310,766

U.S. PATENT NO. 5,310,767

U.S. PATENT NO. 5,310,768

U.S. PATENT NO. 5,310,769

U.S. PATENT NO. 5,310,770

U.S. PATENT NO. 5,310,771

U.S. PATENT NO. 5,310,772

U.S. PATENT NO. 5,310,773

U.S. PATENT NO. 5,310,774

U.S. PATENT NO. 5,310,775

U.S. PATENT NO. 5,310,776

U.S. PATENT NO. 5,310,777

U.S. PATENT NO. 5,310,778

U.S. PATENT NO. 5,310,779

U.S. PATENT NO. 5,310,780

U.S. PATENT NO. 5,310,781

U.S. PATENT NO. 5,310,782

U.S. PATENT NO. 5,310,783

U.S. PATENT NO. 5,310,784

U.S. PATENT NO. 5,310,785

U.S. PATENT NO. 5,310,786

U.S. PATENT NO. 5,310,787

U.S. PATENT NO. 5,310,788

U.S. PATENT NO. 5,310,789

U.S. PATENT NO. 5,310,790

U.S. PATENT NO. 5,310,791

U.S. PATENT NO. 5,310,792

U.S. PATENT NO. 5,310,793

U.S. PATENT NO. 5,310,794

U.S. PATENT NO. 5,310,795

U.S. PATENT NO. 5,310,796

U.S. PATENT NO. 5,310,797

U.S. PATENT NO. 5,310,798

U.S. PATENT NO. 5,310,799

U.S. PATENT NO. 5,310,800

U.S. PATENT NO. 5,310,801

U.S. PATENT NO. 5,310,802

U.S. PATENT NO. 5,310,803

U.S. PATENT NO. 5,310,804

U.S. PATENT NO. 5,310,805

U.S. PATENT NO. 5,310,806

U.S. PATENT NO. 5,310,807

U.S. PATENT NO. 5,310,808

U.S. PATENT NO. 5,310,809

U.S. PATENT NO. 5,310,810

U.S. PATENT NO. 5,310,811

U.S. PATENT NO. 5,310,812

U.S. PATENT NO. 5,310,813

U.S. PATENT NO. 5,310,814

U.S. PATENT NO. 5,310,815

U.S. PATENT NO. 5,310,816

U.S. PATENT NO. 5,310,817

U.S. PATENT NO. 5,310,818

U.S. PATENT NO. 5,310,819

U.S. PATENT NO. 5,310,820

U.S. PATENT NO. 5,310,821

U.S. PATENT NO. 5,310,822

U.S. PATENT NO. 5,310,823

U.S. PATENT NO. 5,310,824

U.S. PATENT NO. 5,310,825

U.S. PATENT NO. 5,310,826

U.S. PATENT NO. 5,310,827

U.S. PATENT NO. 5,310,828

U.S. PATENT NO. 5,310,829

U.S. PATENT NO. 5,310,830

U.S. PATENT NO. 5,310,831

U.S. PATENT NO. 5,310,832

U.S. PATENT NO. 5,310,833

U.S. PATENT NO. 5,310,834

U.S. PATENT NO. 5,310,835

U.S. PATENT NO. 5,310,836

U.S. PATENT NO. 5,310,837

U.S. PATENT NO. 5,310,838

U.S. PATENT NO. 5,310,839

U.S. PATENT NO. 5,310,840

U.S. PATENT NO. 5,310,841

U.S. PATENT NO. 5,310,842

U.S. PATENT NO. 5,310,843

U.S. PATENT NO. 5,310,844

U.S. PATENT NO. 5,310,845

U.S. PATENT NO. 5,310,846

U.S. PATENT NO. 5,310,847

U.S. PATENT NO. 5,310,848

U.S. PATENT NO. 5,310,849

U.S. PATENT NO. 5,310,850

U.S. PATENT NO. 5,310,851

U.S. PATENT NO. 5,310,852

U.S. PATENT NO. 5,310,853

U.S. PATENT NO. 5,310,854

U.S. PATENT NO. 5,310,855

U.S. PATENT NO. 5,310,856

U.S. PATENT NO. 5,310,857

U.S. PATENT NO. 5,310,858

U.S. PATENT NO. 5,310,859

U.S. PATENT NO. 5,310,860

U.S. PATENT NO. 5,310,861

U.S. PATENT NO. 5,310,862

U.S. PATENT NO. 5,310,863

U.S. PATENT NO. 5,310,864

U.S. PATENT NO. 5,310,865

U.S. PATENT NO. 5,310,866

U.S. PATENT NO. 5,310,867

U.S. PATENT NO. 5,310,868

U.S. PATENT NO. 5,310,869

U.S. PATENT NO. 5,310,870

U.S. PATENT NO. 5,310,871

U.S. PATENT NO. 5,310,872

U.S. PATENT NO. 5,310,873

U.S. PATENT NO. 5,310,874

U.S. PATENT NO. 5,310,875

U.S. PATENT NO. 5,310,876

U.S. PATENT NO. 5,310,877

U.S. PATENT NO. 5,310,878

U.S. PATENT NO. 5,310,879

U.S. PATENT NO. 5,310,880

U.S. PATENT NO. 5,310,881

U.S. PATENT NO. 5,310,882

U.S. PATENT NO. 5,310,883

U.S. PATENT NO. 5,310,884

U.S. PATENT NO. 5,310,885

U.S. PATENT NO. 5,310,886

U.S. PATENT NO. 5,310,887

U.S. PATENT NO. 5,310,888

U.S. PATENT NO. 5,310,889

U.S. PATENT NO. 5,310,890

U.S. PATENT NO. 5,310,891

U.S. PATENT NO. 5,310,892

U.S. PATENT NO. 5,310,893

U.S. PATENT NO. 5,310,894

U.S. PATENT NO. 5,310,895

U.S. PATENT NO. 5,310,896

U.S. PATENT NO. 5,310,897

U.S. PATENT NO. 5,310,898

U.S. PATENT NO. 5,310,899

U.S. PATENT NO. 5,310,900

U.S. PATENT NO. 5,310,901

U.S. PATENT NO. 5,310,902

U.S. PATENT NO. 5,310,903

U.S. PATENT NO. 5,310,904

U.S. PATENT NO. 5,310,905

U.S. PATENT NO. 5,310,906

U.S. PATENT NO. 5,310,907

U.S. PATENT NO. 5,310,908

U.S. PATENT NO. 5,310,909

U.S. PATENT NO. 5,310,910

U.S. PATENT NO. 5,310,911

U.S. PATENT NO. 5,310,912

U.S. PATENT NO. 5,310,913

U.S. PATENT NO. 5,310,914

U.S. PATENT NO. 5,310,915

U.S. PATENT NO. 5,310,916

U.S. PATENT NO. 5,310,917

U.S. PATENT NO. 5,310,918

U.S. PATENT NO. 5,310,919

U.S. PATENT NO. 5,310,920

U.S. PATENT NO. 5,310,921

U.S. PATENT NO. 5,310,922

U.S. PATENT NO. 5,310,923

U.S. PATENT NO. 5,310,924

U.S. PATENT NO. 5,310,925

U.S. PATENT NO. 5,310,926

U.S. PATENT NO. 5,310,927

U.S. PATENT NO. 5,310,928

U.S. PATENT NO. 5,310,929

U.S. PATENT NO. 5,310,930

U.S. PATENT NO. 5,310,931

U.S. PATENT NO. 5,310,932

U.S. PATENT NO. 5,310,933

U.S. PATENT NO. 5,310,934

U.S. PATENT NO. 5,310,935

U.S. PATENT NO. 5,310,936

U.S. PATENT NO. 5,310,937

U.S. PATENT NO. 5,310,938

U.S. PATENT NO. 5,310,939

U.S. PATENT NO. 5,310,940

U.S. PATENT NO. 5,310,941

U.S. PATENT NO. 5,310,942

U.S. PATENT NO. 5,310,943

U.S. PATENT NO. 5,310,944

U.S. PATENT NO. 5,310,945

U.S. PATENT NO. 5,310,946

U.S. PATENT NO. 5,310,947

U.S. PATENT NO. 5,310,948

U.S. PATENT NO. 5,310,949

U.S. PATENT NO. 5,310,950

U.S. PATENT NO. 5,310,951

U.S. PATENT NO. 5,310,952

U.S. PATENT NO. 5,310,953

U.S. PATENT NO. 5,310,954

U.S. PATENT NO. 5,310,955

U.S. PATENT NO. 5,310,956

U.S. PATENT NO. 5,310,957

U.S. PATENT NO. 5,310,958

U.S. PATENT NO. 5,310,959

U.S. PATENT NO. 5,310,960

U.S. PATENT NO. 5,310,961

U.S. PATENT NO. 5,310,962

U.S. PATENT NO. 5,310,963

U.S. PATENT NO. 5,310,964

U.S. PATENT NO. 5,310,965

U.S. PATENT NO. 5,310,966

U.S. PATENT NO. 5,310,967

U.S. PATENT NO. 5,310,968

U.S. PATENT NO. 5,310,969

U.S. PATENT NO. 5,310,970

U.S. PATENT NO. 5,310,971

U.S. PATENT NO. 5,310,972

U.S. PATENT NO. 5,310,973

U.S. PATENT NO. 5,310,974

U.S. PATENT NO. 5,310,975

U.S. PATENT NO. 5,310,976

U.S. PATENT NO. 5,310,977

U.S. PATENT NO. 5,310,978

U.S. PATENT NO. 5,310,979

U.S. PATENT NO. 5,310,980

U.S. PATENT NO. 5,310,981

U.S. PATENT NO. 5,310,982

U.S. PATENT NO. 5,310,983

U.S. PATENT NO. 5,310,984

U.S. PATENT NO. 5,310,985

U.S. PATENT NO. 5,310,986

U.S. PATENT NO. 5,310,987

U.S. PATENT NO. 5,310,988

U.S. PATENT NO. 5,310,989

U.S. PATENT NO. 5,310,990

U.S. PATENT NO. 5,310,991

U.S. PATENT NO. 5,310,992

U.S. PATENT NO. 5,310,993

U.S. PATENT NO. 5,310,994

U.S. PATENT NO. 5,310,995

U.S. PATENT NO. 5,310,996

U.S. PATENT NO. 5,310,997

U.S. PATENT NO. 5,310,998

U.S. PATENT NO. 5,310,999

U.S. PATENT NO. 5,311,000

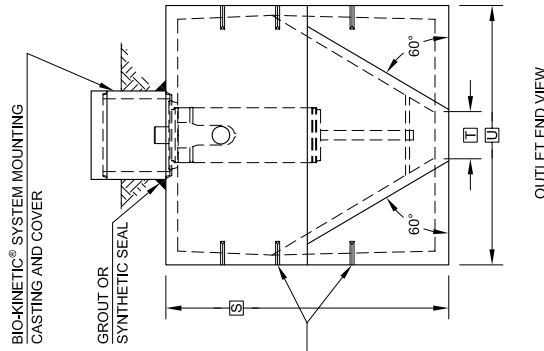
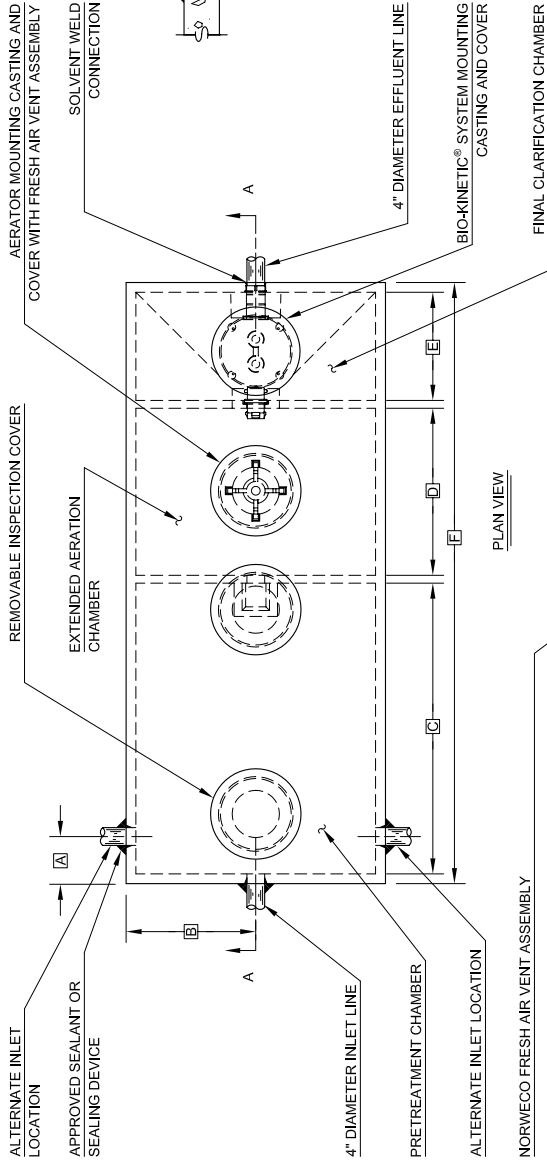
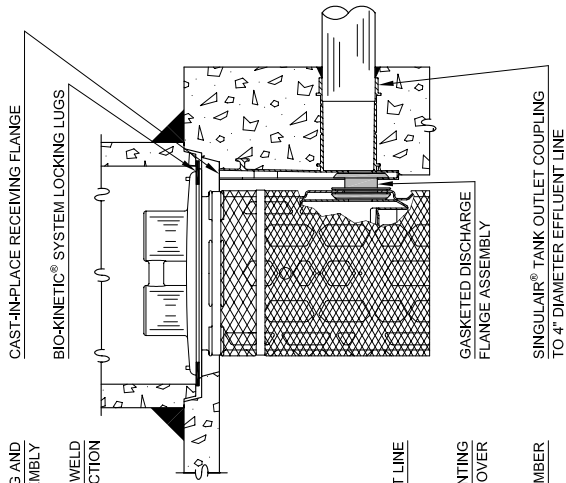

NOTE: TOTAL SYSTEM CAPACITY: 1,850 GALLONS  
RATED CAPACITY: 500 GALLONS PER DAY

**SECTION A-A**

BIO-STATIC® SLUDGE RETURN

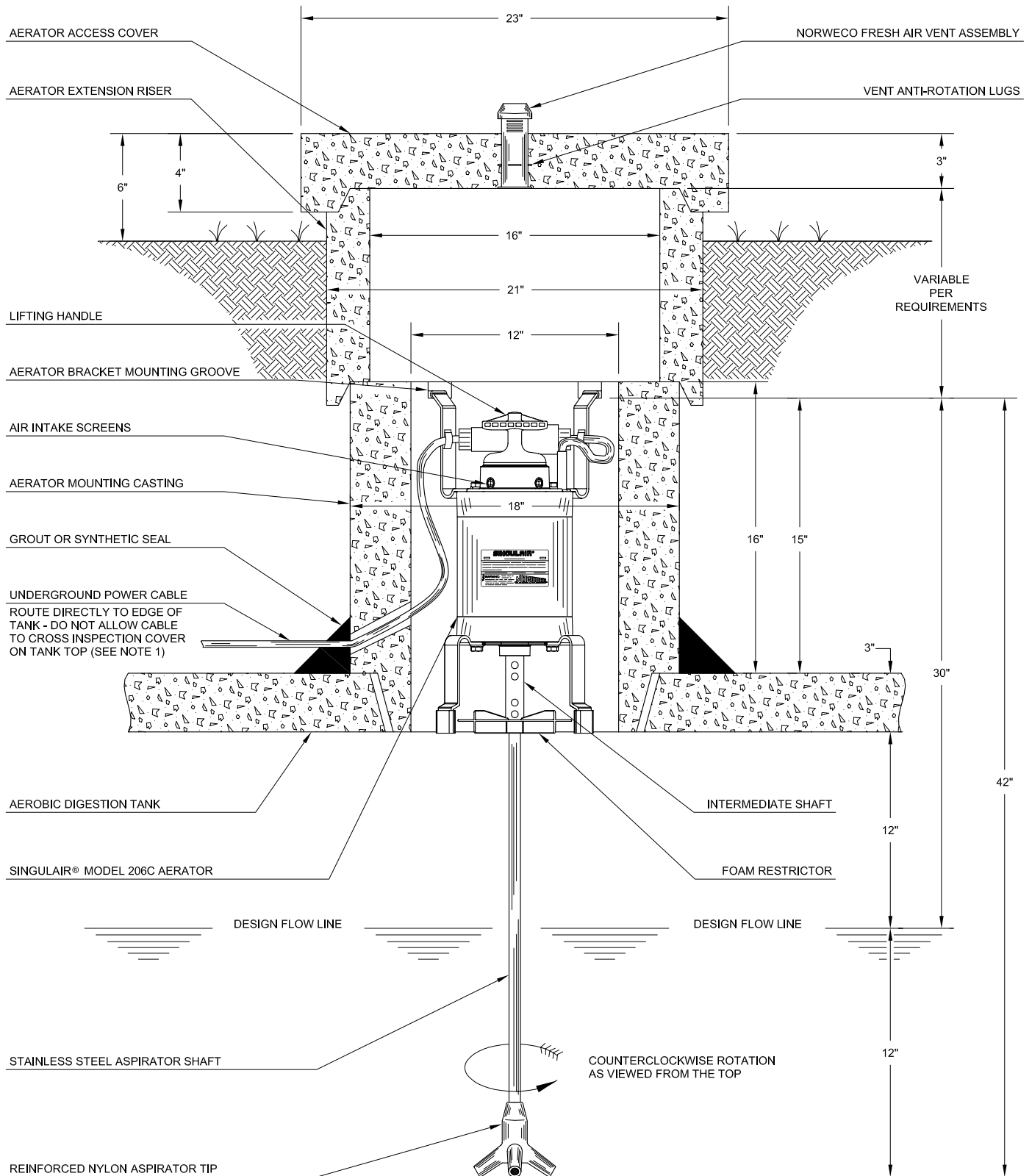

**GENERAL NOTES:**

1. UNDERGROUND POWER SUPPLY MUST BE WIRED INTO AN APPROVED SINGULAIR® CONTROL CENTER.
2. SINGULAIR® CONTROL CENTER MUST BE WIRED INTO A SEPARATE 10 AMP CIRCUIT BREAKER AT MAIN ELECTRICAL SERVICE PANEL IN THE FACILITY.
3. AERATOR AND AERATOR CONTROL CENTER MUST BE PROPERLY GROUNDED.
4. THE LOCAL, LICENSED NORWECO DISTRIBUTOR WILL PLACE THE AERATOR INTO SERVICE.

U.S. AND FOREIGN PATENTS PENDING  © MMVI	<b>norweco</b>		APPROVED BY: 7-6-06 DRAWN BY: JMM
	MODEL 206C SINGULAIR® AERATOR MOUNTING AND INSTALLATION DETAIL		APPROVED BY: GJS DATE: 1-8-95 SCALE: NTS
	THIS DRAWING IS THE PROPERTY OF NORWECO. NO PARTS OF THIS DRAWING OR ANY INFORMATION CONTAINED HEREIN SHALL BE REPRODUCED OR TRANSMITTED IN ANY FORM OR BY ANY MEANS, ELECTRONIC OR MECHANICAL, INCLUDING PHOTOCOPYING, RECORDING, OR BY ANY INFORMATION STORAGE AND RETRIEVAL SYSTEM, WITHOUT THE WRITTEN PERMISSION OF NORWECO.		DRAWING NO.: PC-5-7600

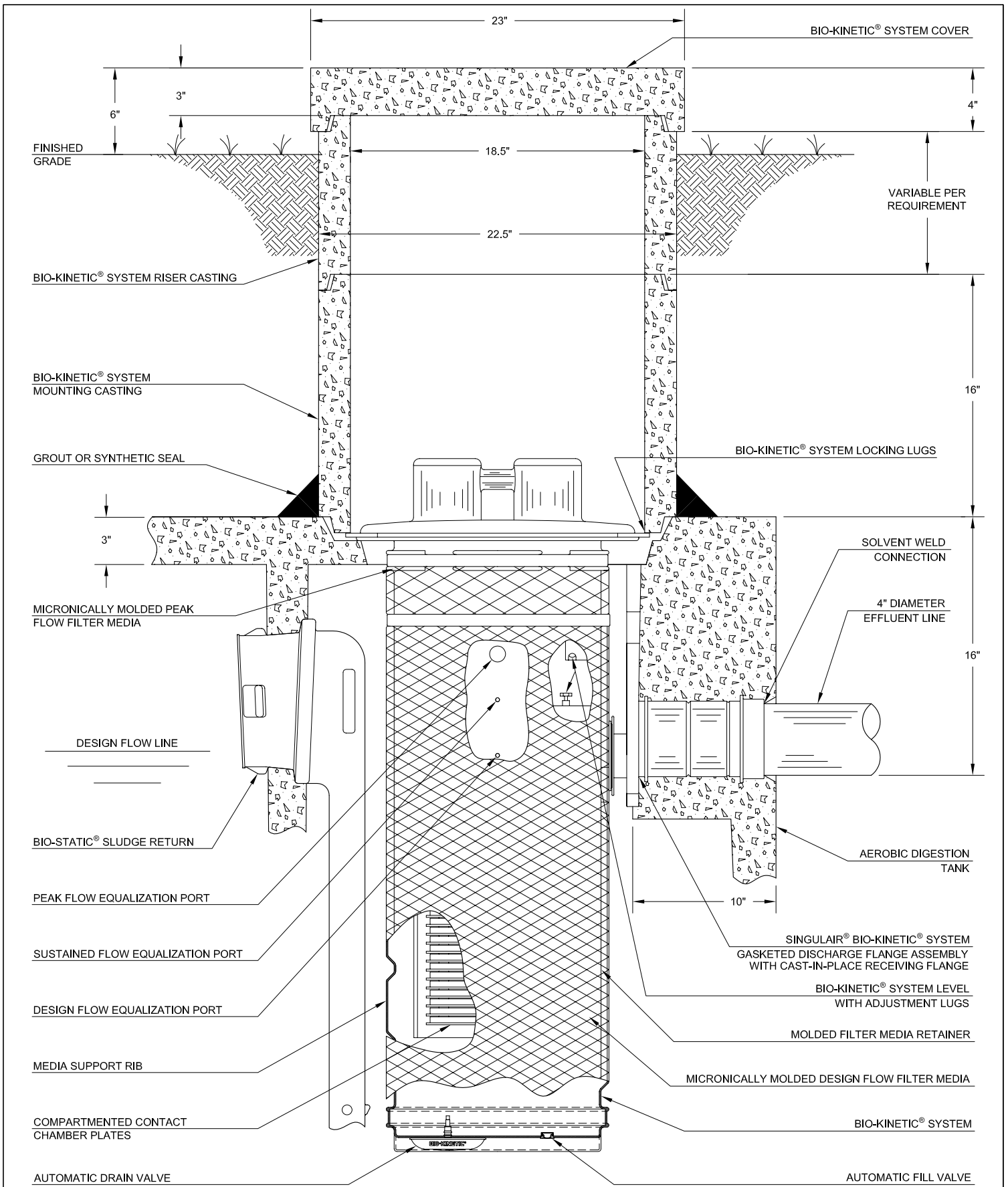

**GENERAL NOTES:**

- ① AFTER INSTALLATION, ALL CHAMBERS OF THE SINGLAIR TANK SHOULD BE FULL TO THE FLOW LINE WITH CLEAN HOLD DOWN WATER.
- ② INTERNAL AND EXTERNAL PRESSURE EQUALIZATION ON THE BIO-KINETIC SYSTEM IS MANAGED AUTOMATICALLY BY THE DRAIN VALVE AND FILL VALVE.

U.S. AND FOREIGN PATENTS PENDING  © MMVII	<b>norweco</b>	REVISION DATE	REVISION
	BIO-KINETIC <sup>®</sup> MOUNTING AND INSTALLATION DETAIL	APPROVED BY	BDS
		DATE	JMM
		SCALE	9-13-07
		CONTROL NO.	NTS
			PC-5-7106

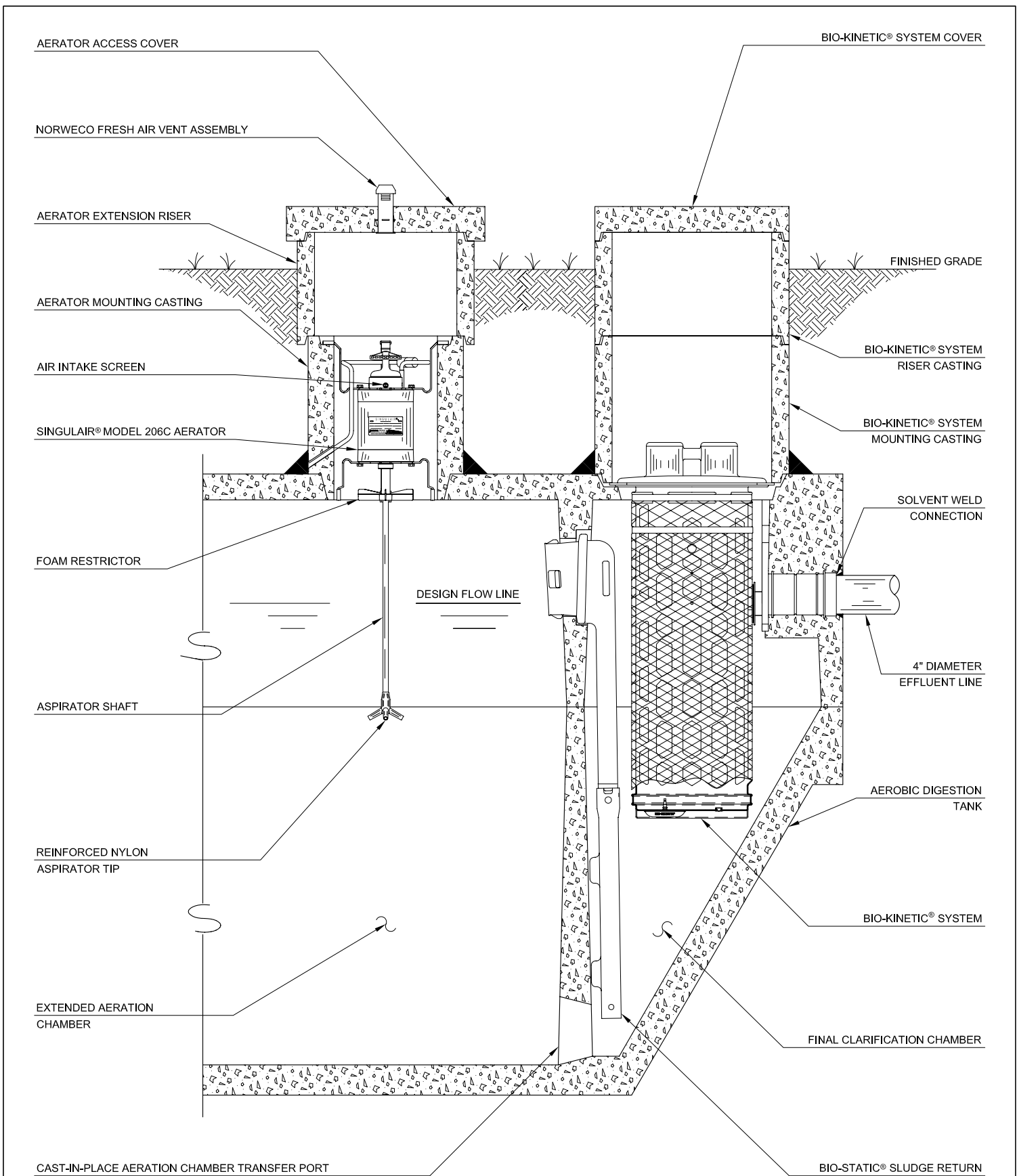

**GENERAL NOTES:**

- ① BIO-STATIC® SLUDGE RETURNS MUST BE INSTALLED PRIOR TO INSTALLATION OF THE BIO-KINETIC® SYSTEM MOUNTING CASTINGS.
- ② ONE BIO-STATIC® SLUDGE RETURN ASSEMBLY IS REQUIRED FOR 500 GPD, 750 GPD AND 1000 GPD SYSTEMS. TWO BIO-STATIC® SLUDGE RETURN ASSEMBLIES ARE REQUIRED FOR 1250 GPD AND 1500 GPD SYSTEMS.
- ③ THE BIO-STATIC® SLUDGE RETURN IS INSTALLED IN THE FINAL CLARIFICATION CHAMBER DURING TANK SETTING.
- ④ ONCE INSTALLED, THE BIO-STATIC® SLUDGE RETURN REMAINS IN PLACE AND NEEDS NO SERVICE OR MAINTENANCE.

U.S. AND FOREIGN PATENTS PENDING  © MMVII	<b>norweco</b>	REVISION DATE	REVISION
	BIO-STATIC® SLUDGE RETURN MOUNTING AND INSTALLATION DETAIL	DRAWN BY	BDS
		APPROVED BY	JMM
		DATE	9-13-07
		SCALE	NTS
		DRAWING NO.	PC-5-7107

# 120 VOLT - 1Ø - 60 Hz - 20 AMP SERVICE

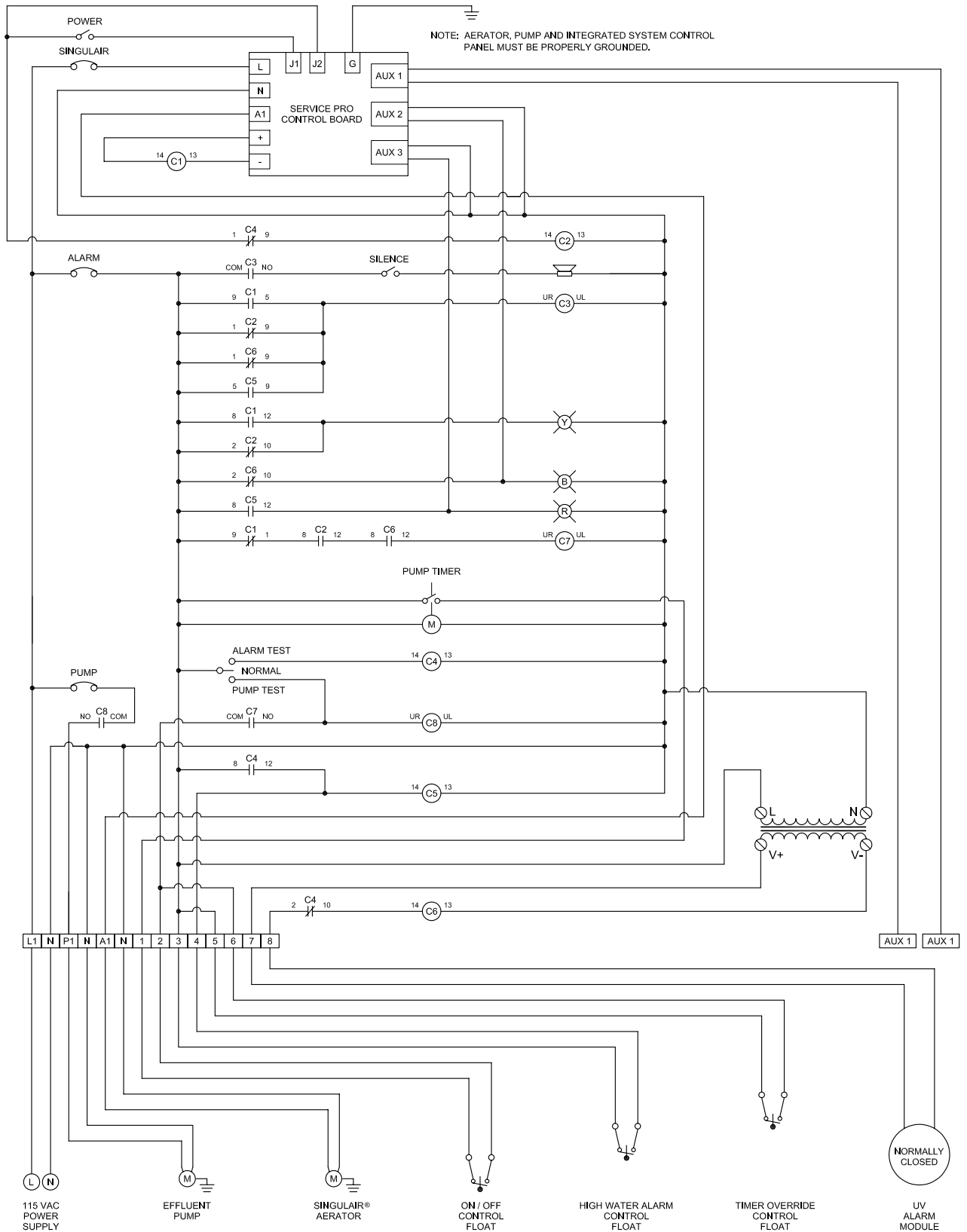

**GENERAL NOTES:**

- ① A DEDICATED 20 AMP CIRCUIT BREAKER AT MAIN SERVICE PANEL SHOULD NOT BE ENERGIZED UNTIL THE AERATOR IS INSTALLED AND READY TO BE PLACED INTO OPERATION.
- ② INSURE THE AERATOR IS OPERATING WHEN THE FACILITY IS OCCUPIED.
- ③ THE LOCAL, LICENSED NORWECO DISTRIBUTOR WILL PLACE THE AERATOR INTO SERVICE.

PART NUMBER: LTS00275			
U.S. AND FOREIGN PATENTS PENDING  © MMVII	<b><i>norweco</i></b>	DRAWN BY: 6-15-07 CHECKED BY: BDS APPROVED BY: JMM DATE: 6-11-07 SCALE: NTS	REVISION: B DATE: 6-11-07 SCALE: NTS
	SERVICE PRO ISC HYBRID SIMPLEX / SIMPLEX TNT DRIP FAIL-SAFE WIRING DIAGRAM		
	THIS DOCUMENT IS THE PROPERTY OF NORWECO. IT IS LOANED TO YOUR FACILITY FOR YOUR USE ONLY. IT IS NOT TO BE REPRODUCED OR TRANSMITTED IN ANY FORM OR BY ANY MEANS, ELECTRONIC OR MECHANICAL, INCLUDING PHOTOCOPYING, RECORDING, OR BY ANY INFORMATION STORAGE AND RETRIEVAL SYSTEM.		
	DRAWING NO. PC-2-0538		



# ***norweco***® **SINGULAIR**®

## BIO-KINETIC® WASTEWATER TREATMENT SYSTEM **RECOMMENDED INSTALLATION INSPECTION GUIDANCE STATE OF OREGON**

This checklist summarizes the installation inspection procedures to be performed during a routine Singulair Bio-Kinetic installation inspection.

### INSPECTION CHECKLIST

Date \_\_\_\_\_

Site Address \_\_\_\_\_

Permit Number \_\_\_\_\_

City \_\_\_\_\_ County \_\_\_\_\_ State \_\_\_\_\_

System Installer \_\_\_\_\_

System Owner \_\_\_\_\_

#### INSTALLATION DOCUMENTATION

- Permit Available
- Approved Plans Available
- Benchmark & Baseline Visible

#### CONDITION OF SITE AND TANKS

- Installation Complete Per Approved Plans
- Tank Installation Level
- All Access Opening At or Above Grade
- Access Covers in Position
- Vented Cover Over Aeration Chamber
- Inlet and Outlet Piping Connected

#### ELECTRICAL WIRING & CONTROL CENTER INSTALLATION

- Underground Power Cable Installed
- Main Electrical Distribution Box Viewable
- Control Center Installation Complete
- Telephone Line Connected to Control Center
- Control Center Operating

#### INTERNAL COMPONENTS

- Aerator Installed
- Electrical Connector Wire
- Aerator Operational
- Bio-Kinetic System Installed
- System Locking Lugs Engaged
- Station(s) Operational

NOTES/COMMENTS: \_\_\_\_\_

\_\_\_\_\_

\_\_\_\_\_

**PROGRESS THROUGH**

***norweco***®  
www.norweco.com

**SERVICE SINCE 1906**