

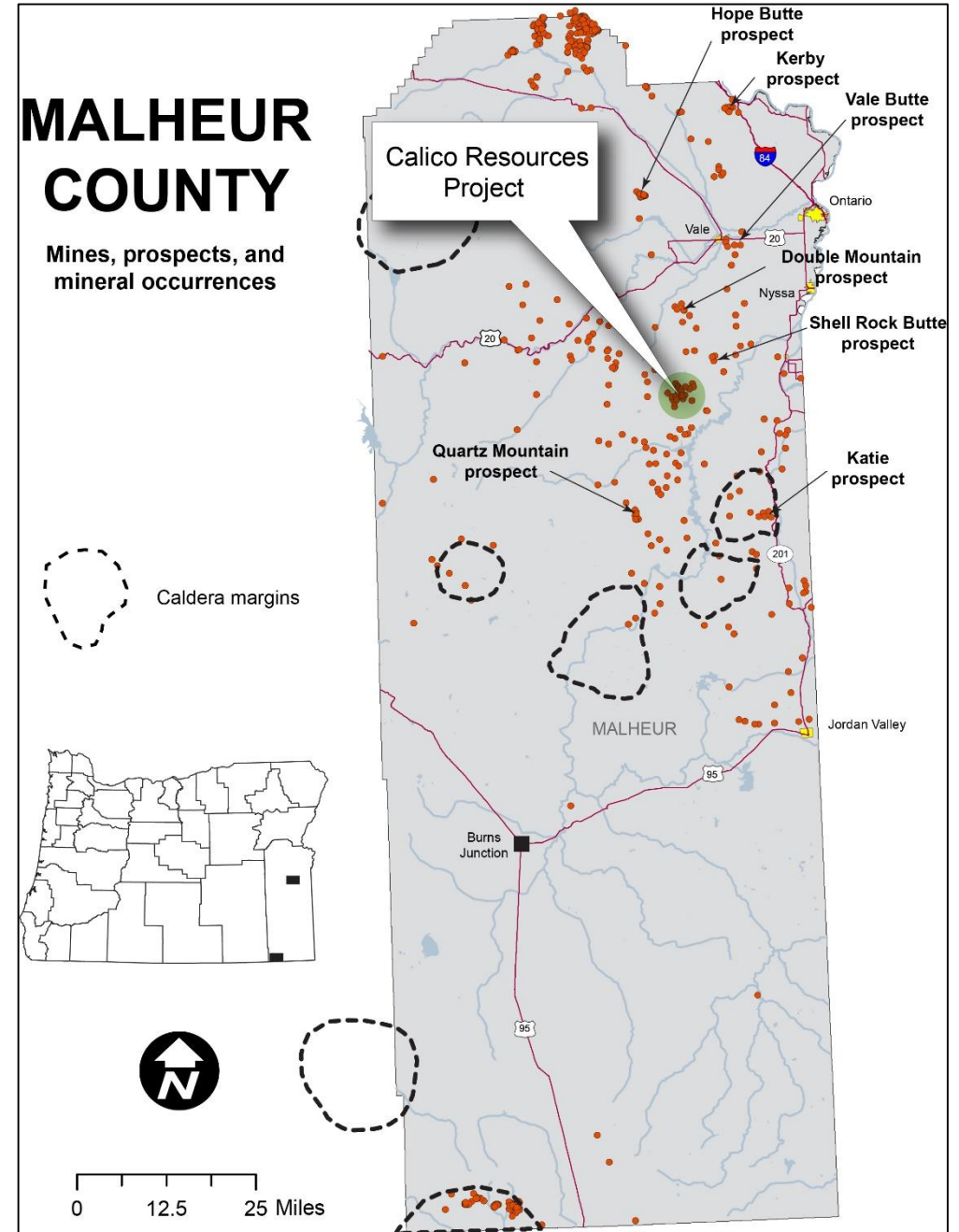

Grassy Mountain Project Malheur County, Oregon: A Summary

Bob Houston, RG
Hydrocarbon & Metallic Ore Geologist



Grassy Mountain Timeline

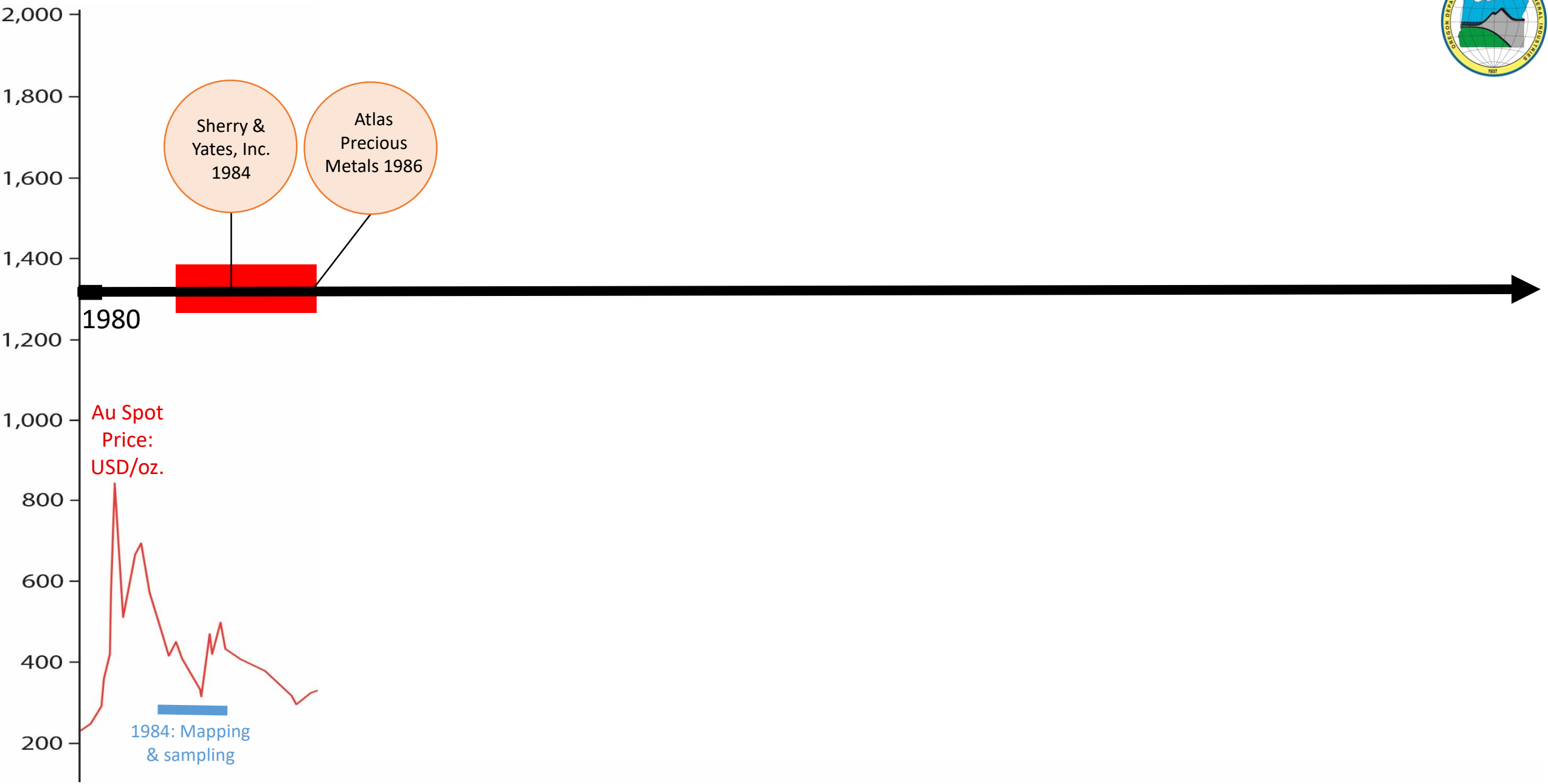
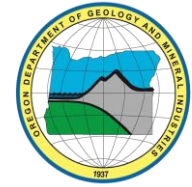

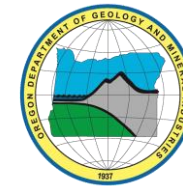

Regional Geologic Map and Lithologic Units

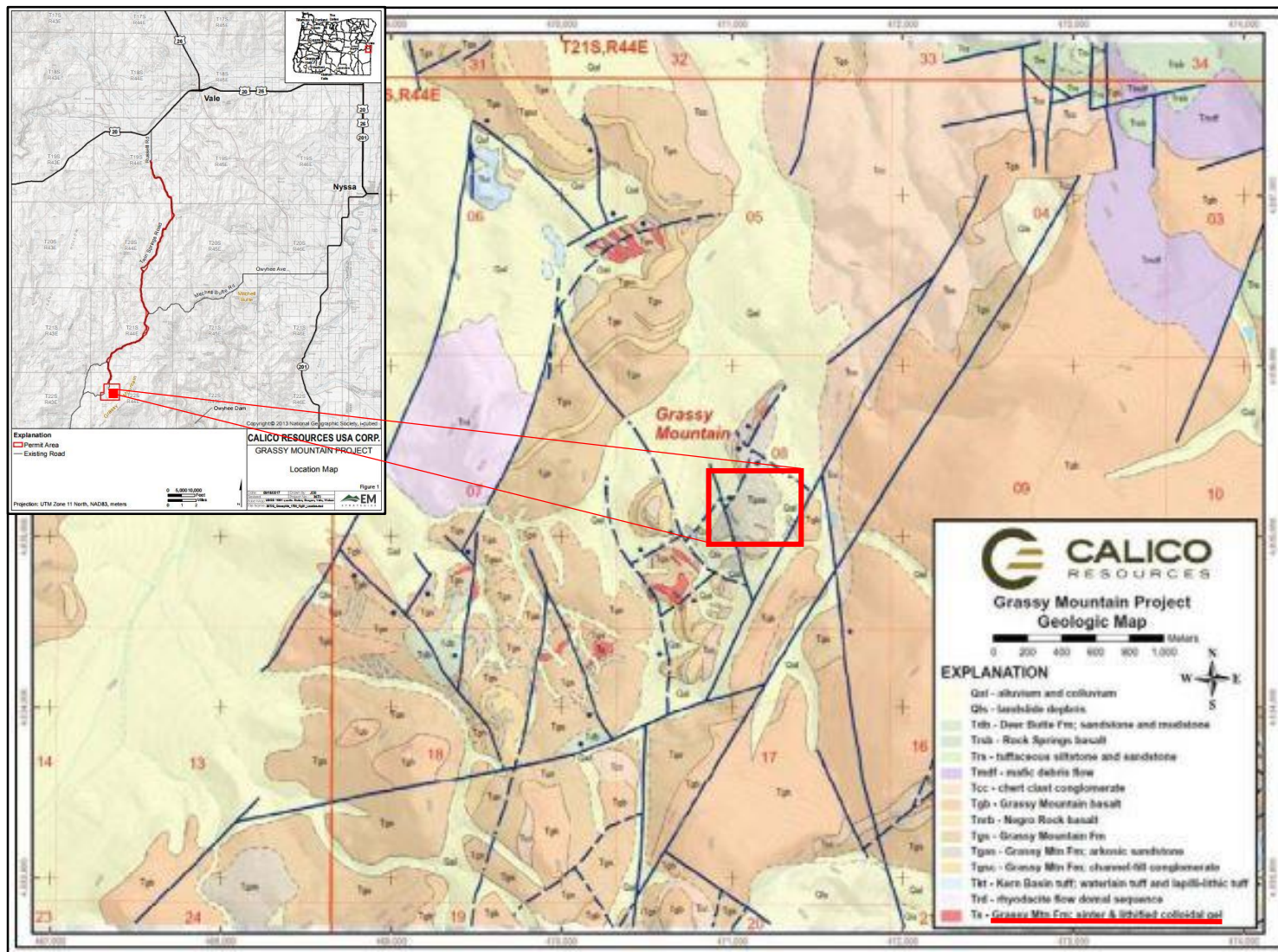

Grassy Mountain

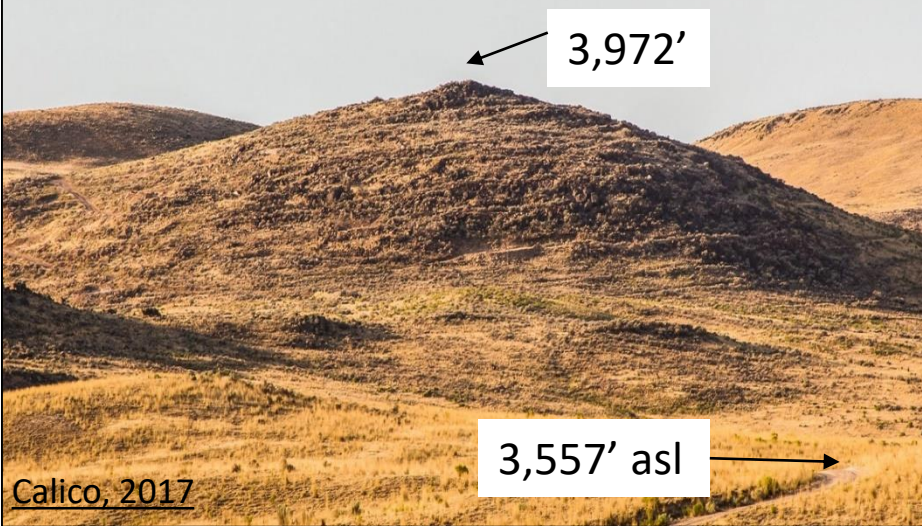
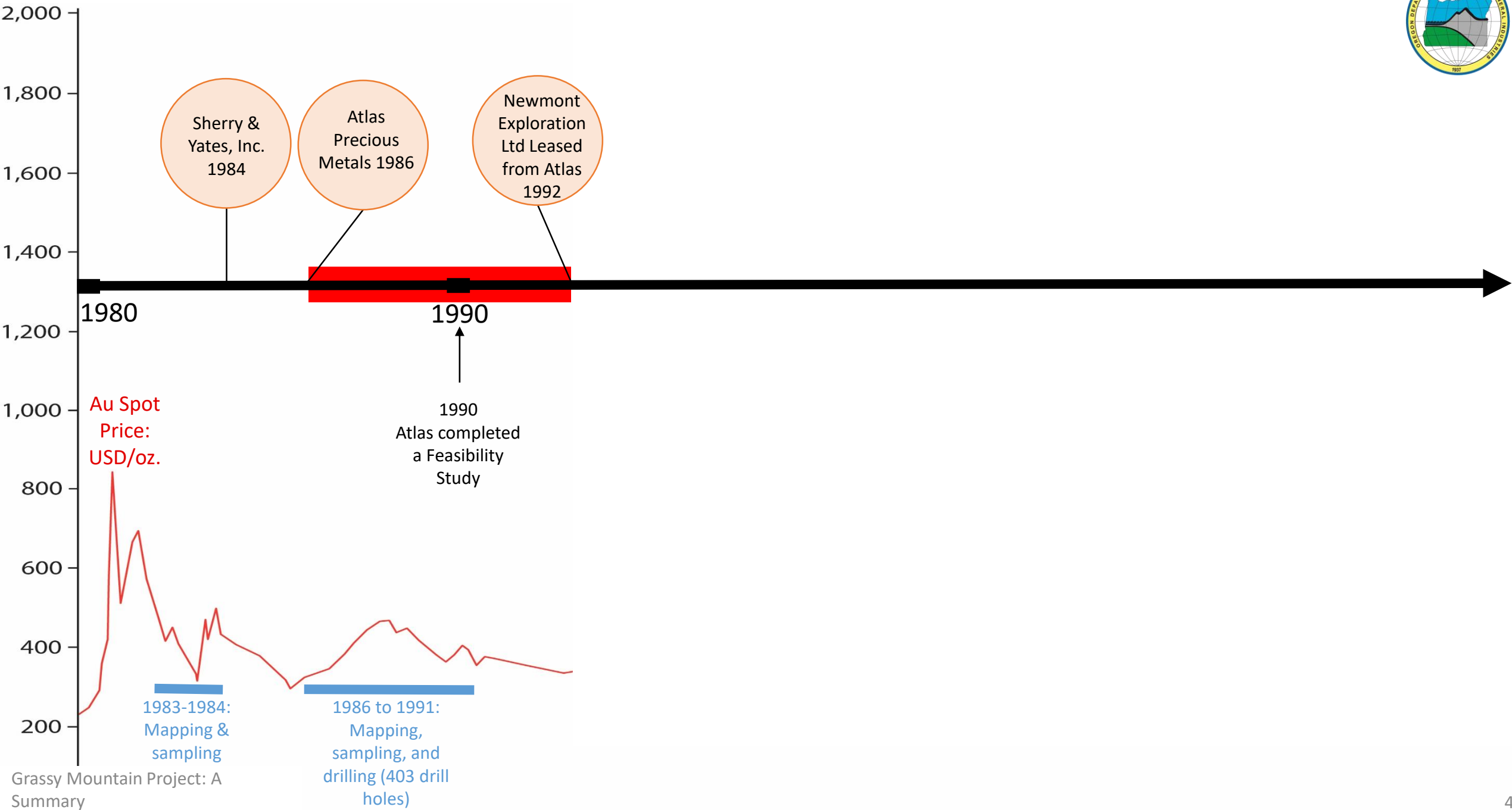
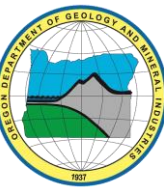
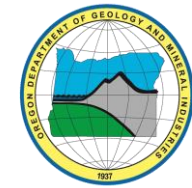

Figure modified from Metal Mining Consultants Inc., (2015)

Grassy Mountain Timeline





Exploration phase: Continuous

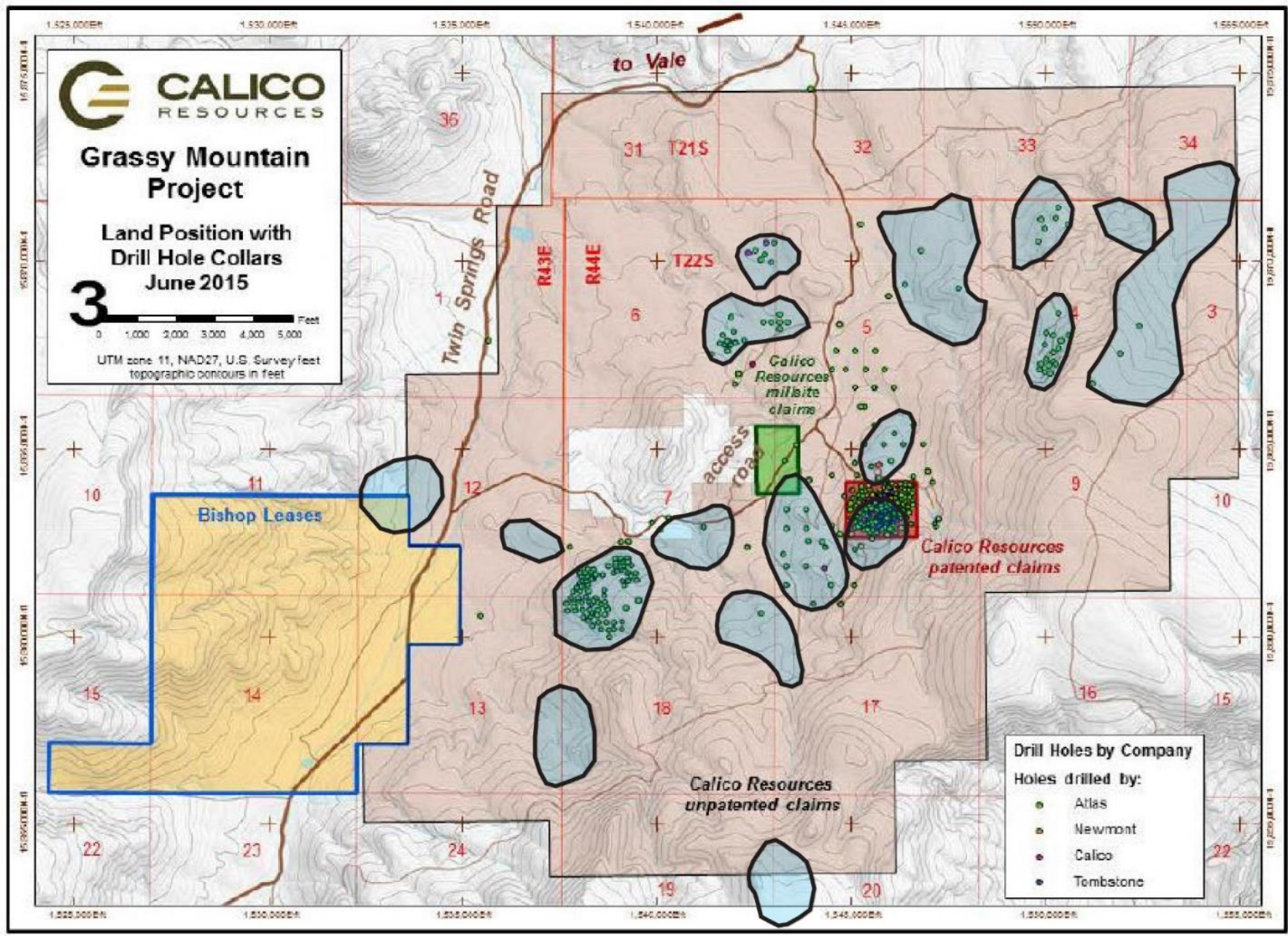

Figure modified from Metal Mining Consultants Inc., (2015)

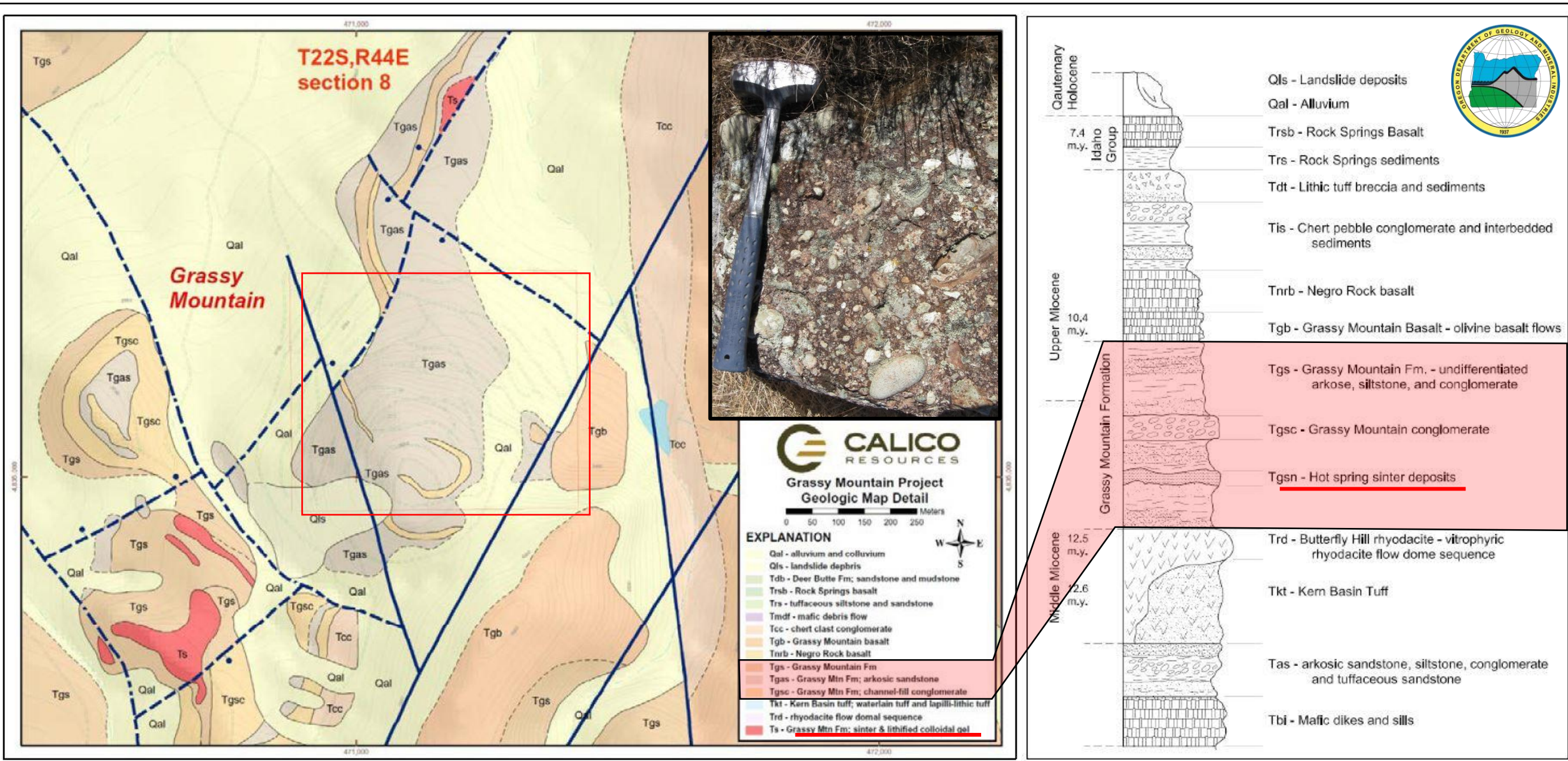
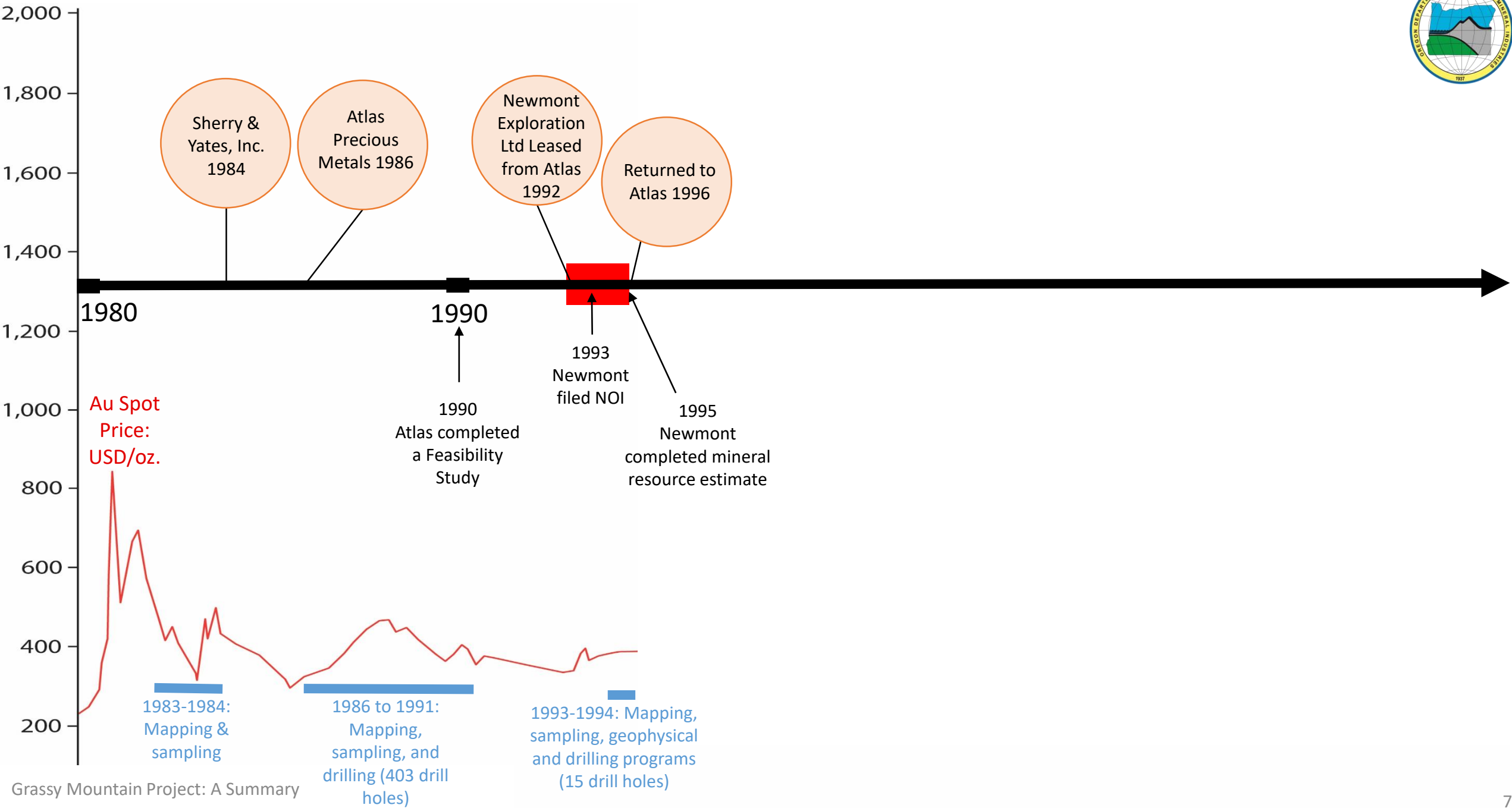
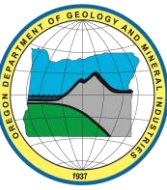
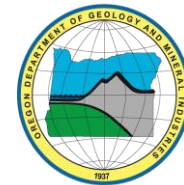

Figure modified from Metal Mining Consultants Inc., (2015)

Figure modified from Metal Mining Consultants Inc., (2015)

Grassy Mountain Timeline





Exploration phase: Continuous

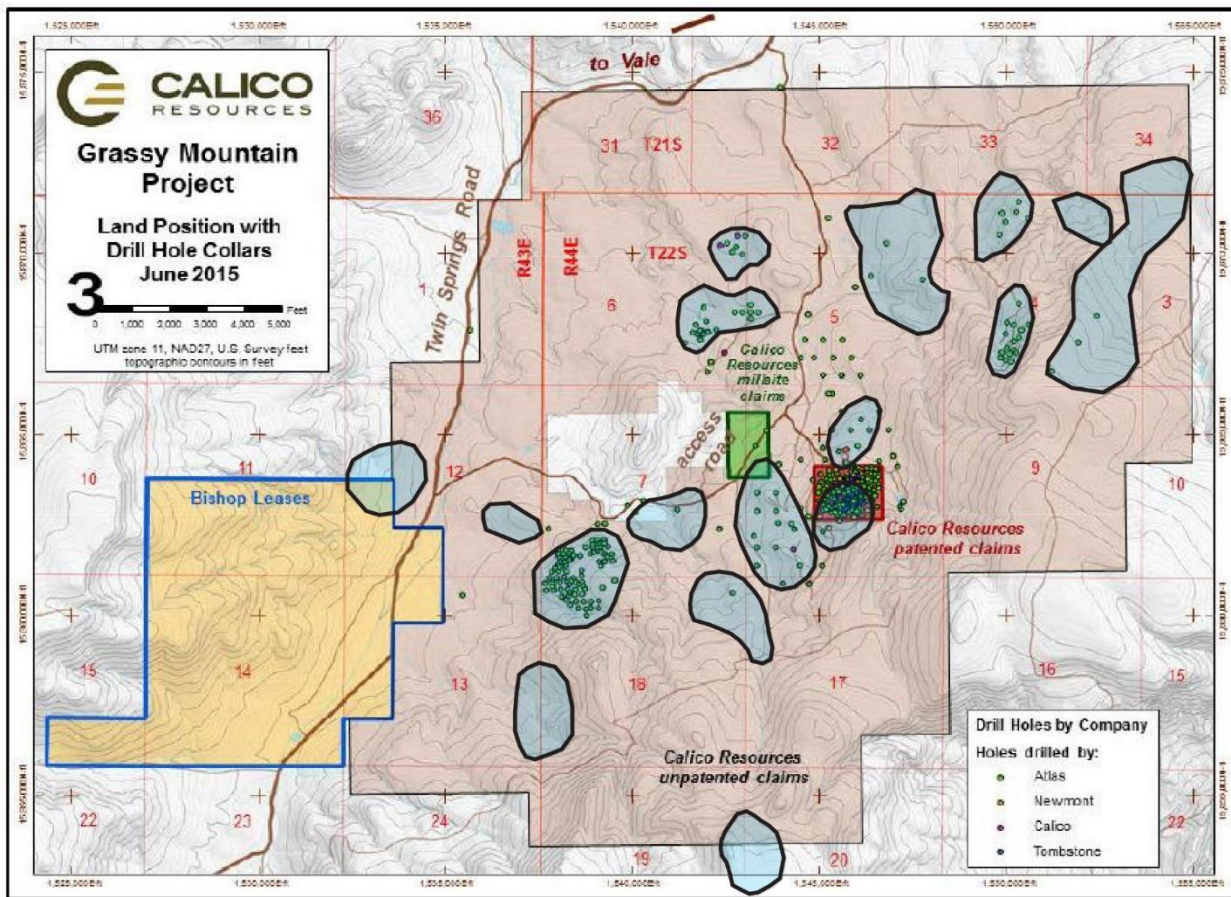
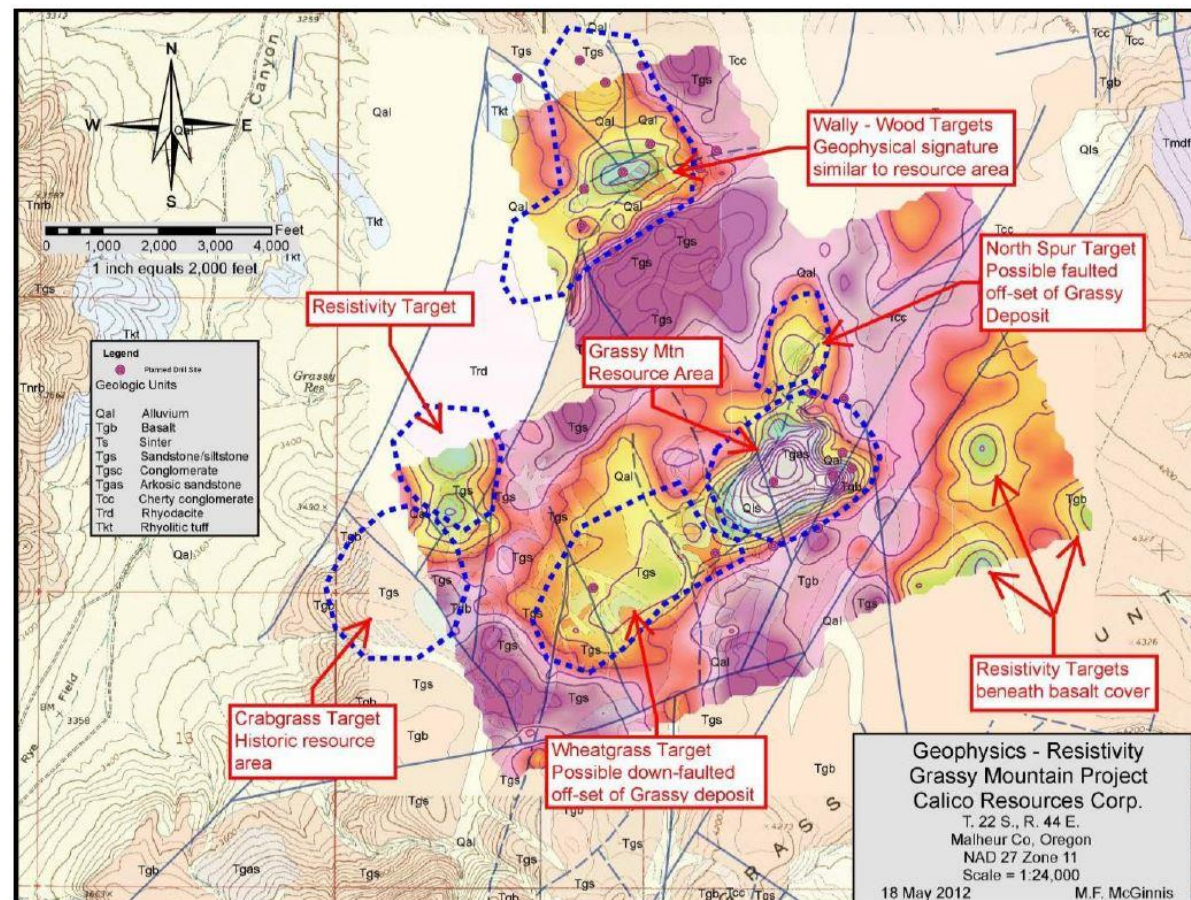

Figure modified from Metal Mining Consultants Inc., (2015)



Metal Mining Consultants Inc., (2015)

Grassy Mountain Timeline

Building a detailed geologic model

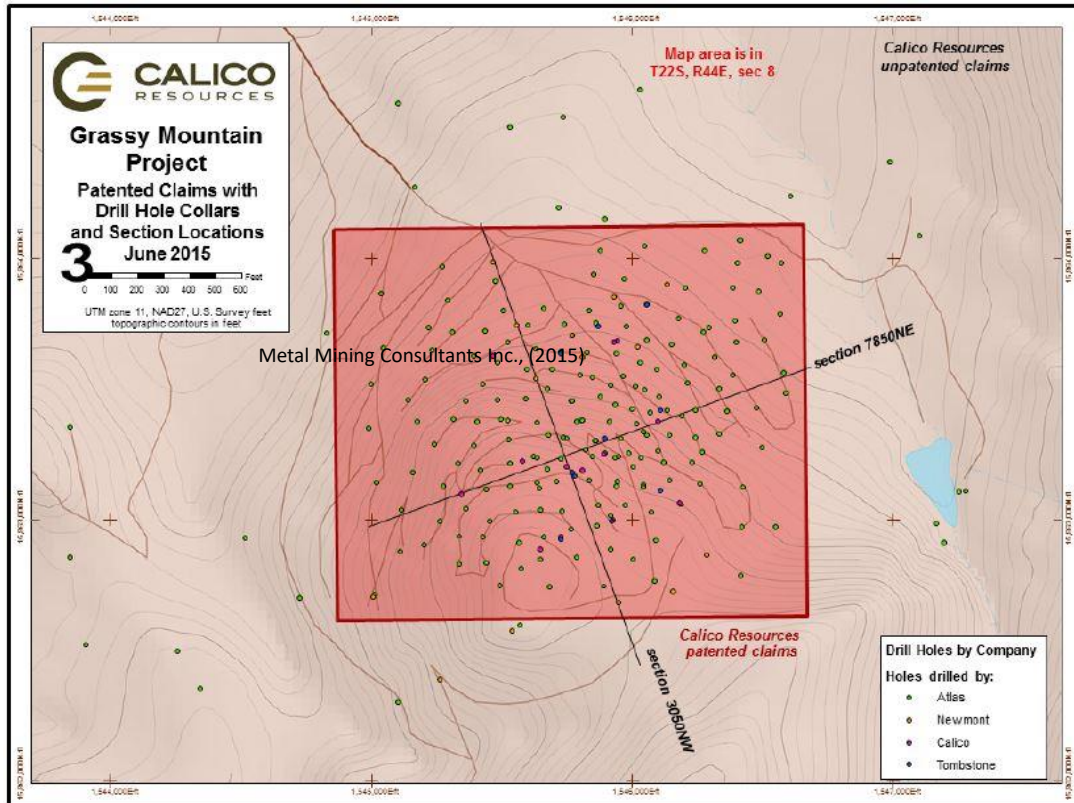

Metal Mining Consultants Inc., (2015)

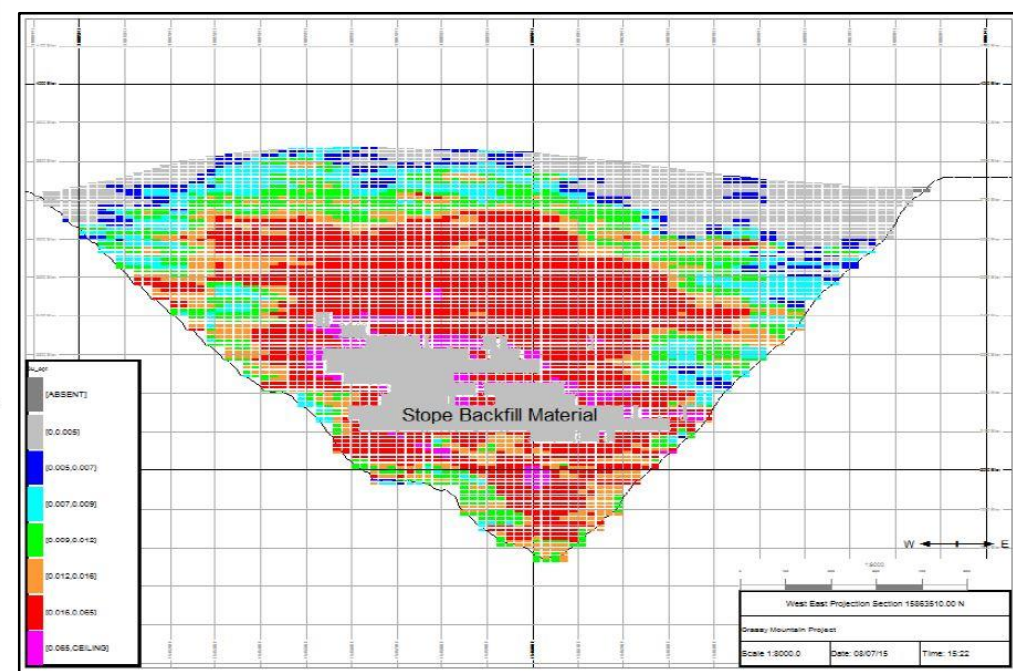
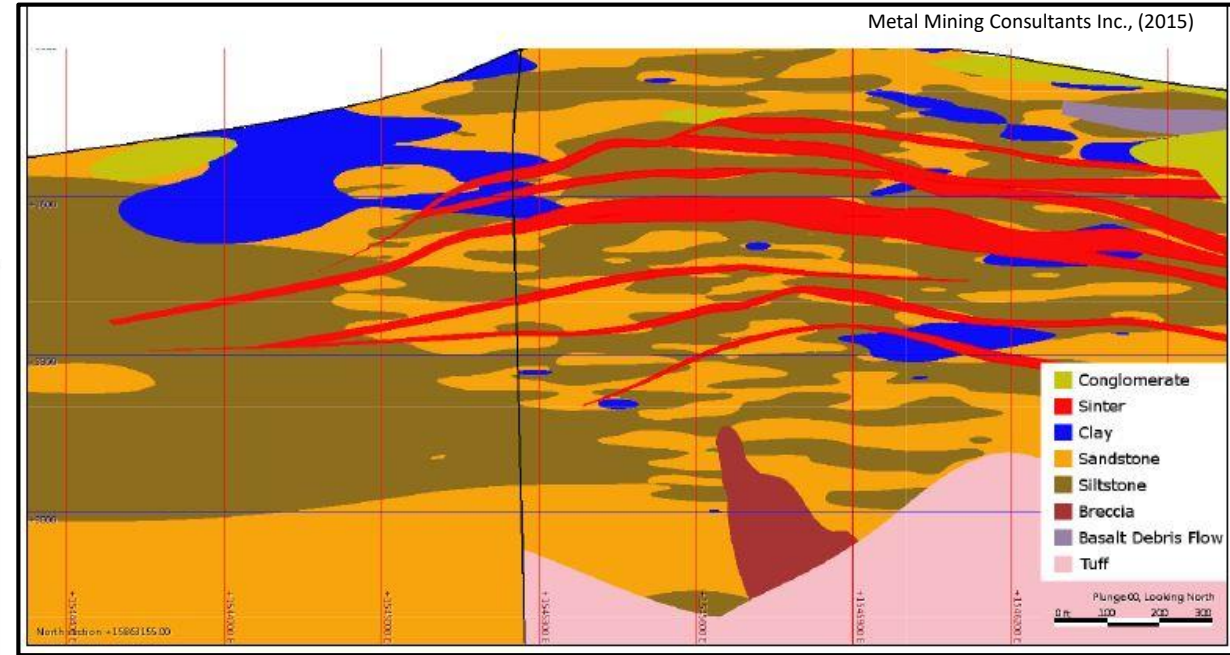

Metal Mining Consultants Inc., (2015)

Metal Mining Consultants Inc., (2015)



Grassy Mountain Timeline

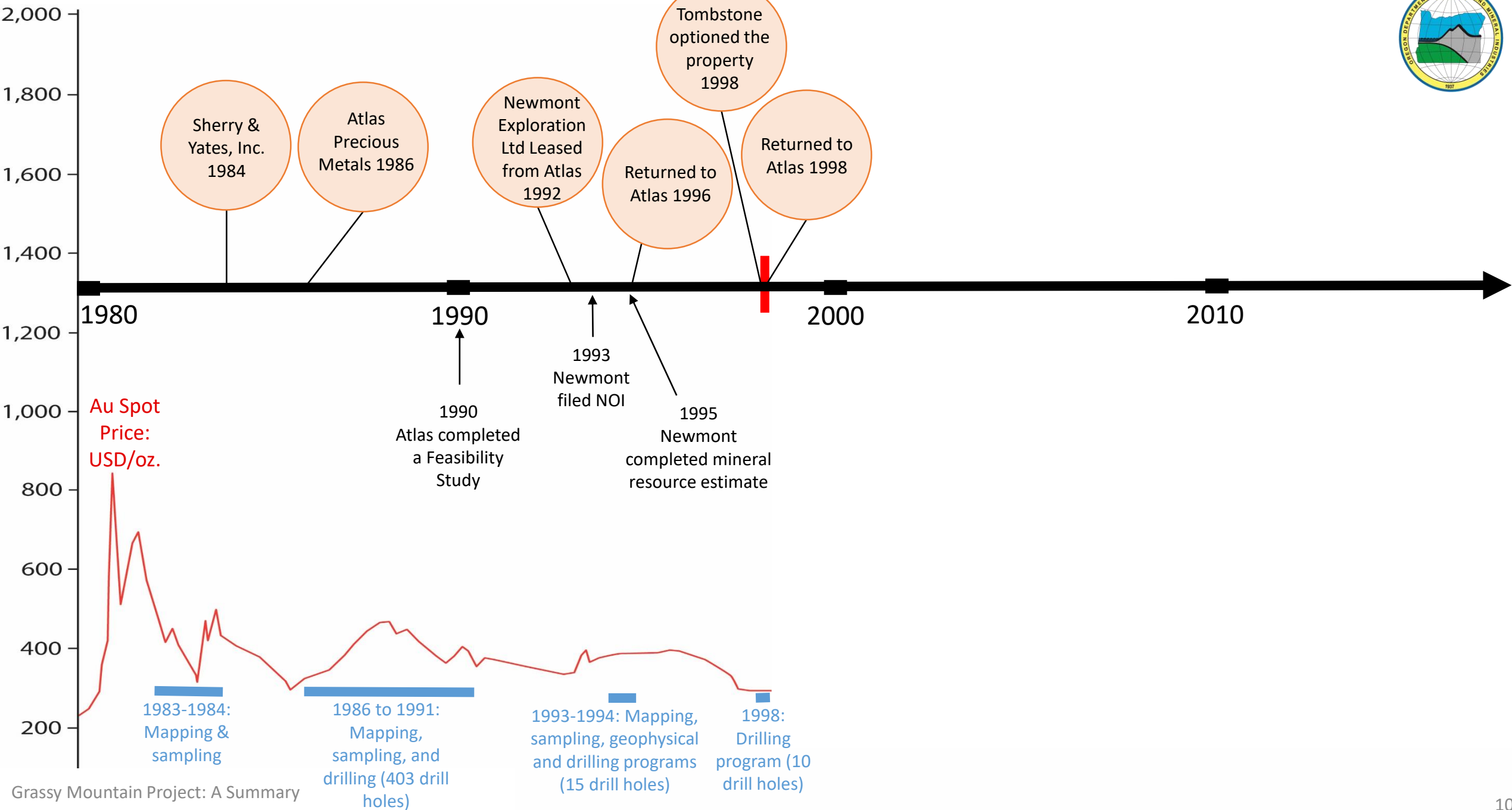
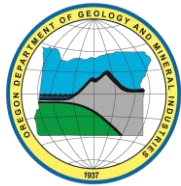

Data Collection

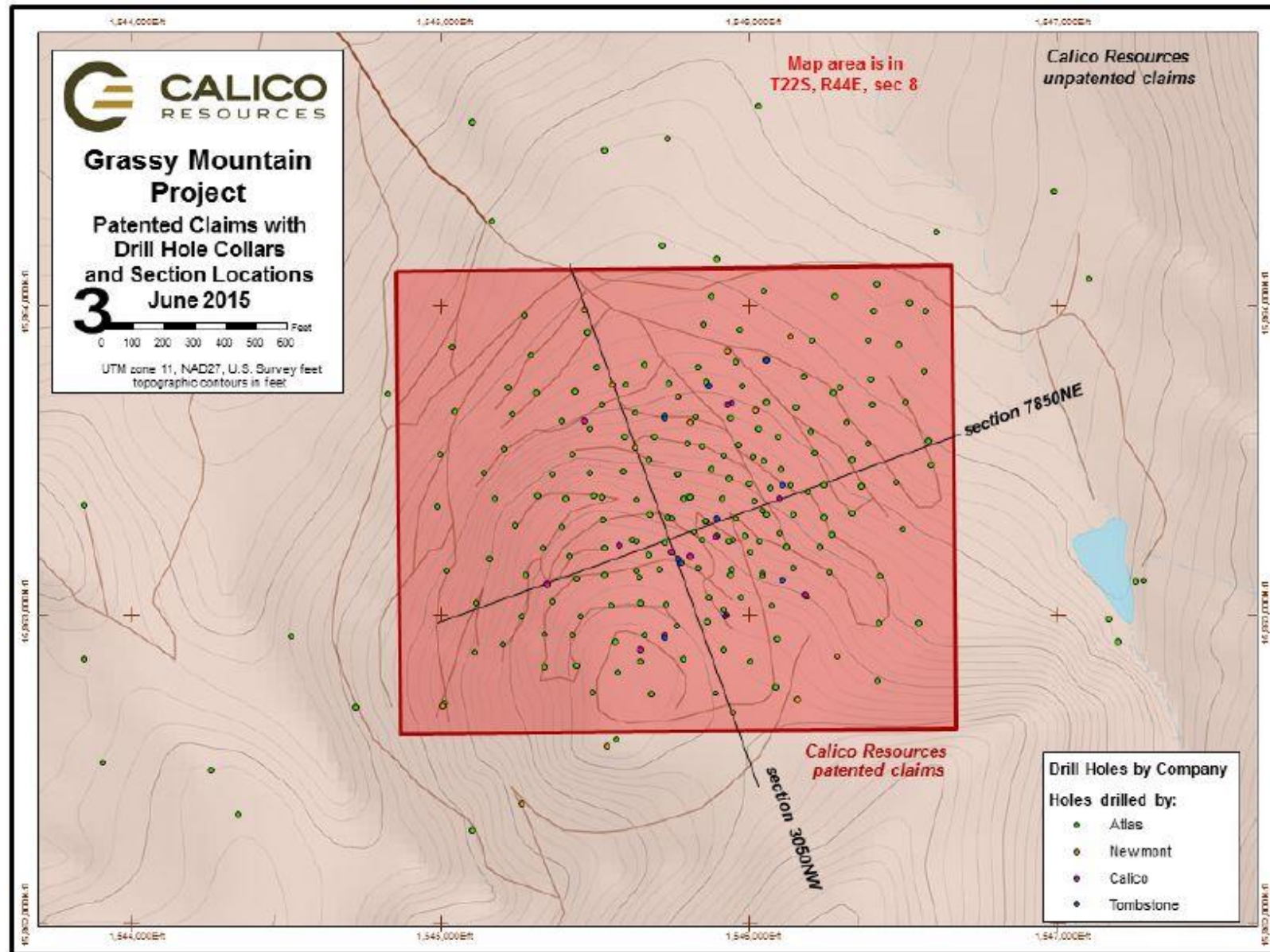
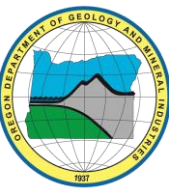

Metal Mining Consultants Inc., (2015)

Grassy Mountain Timeline

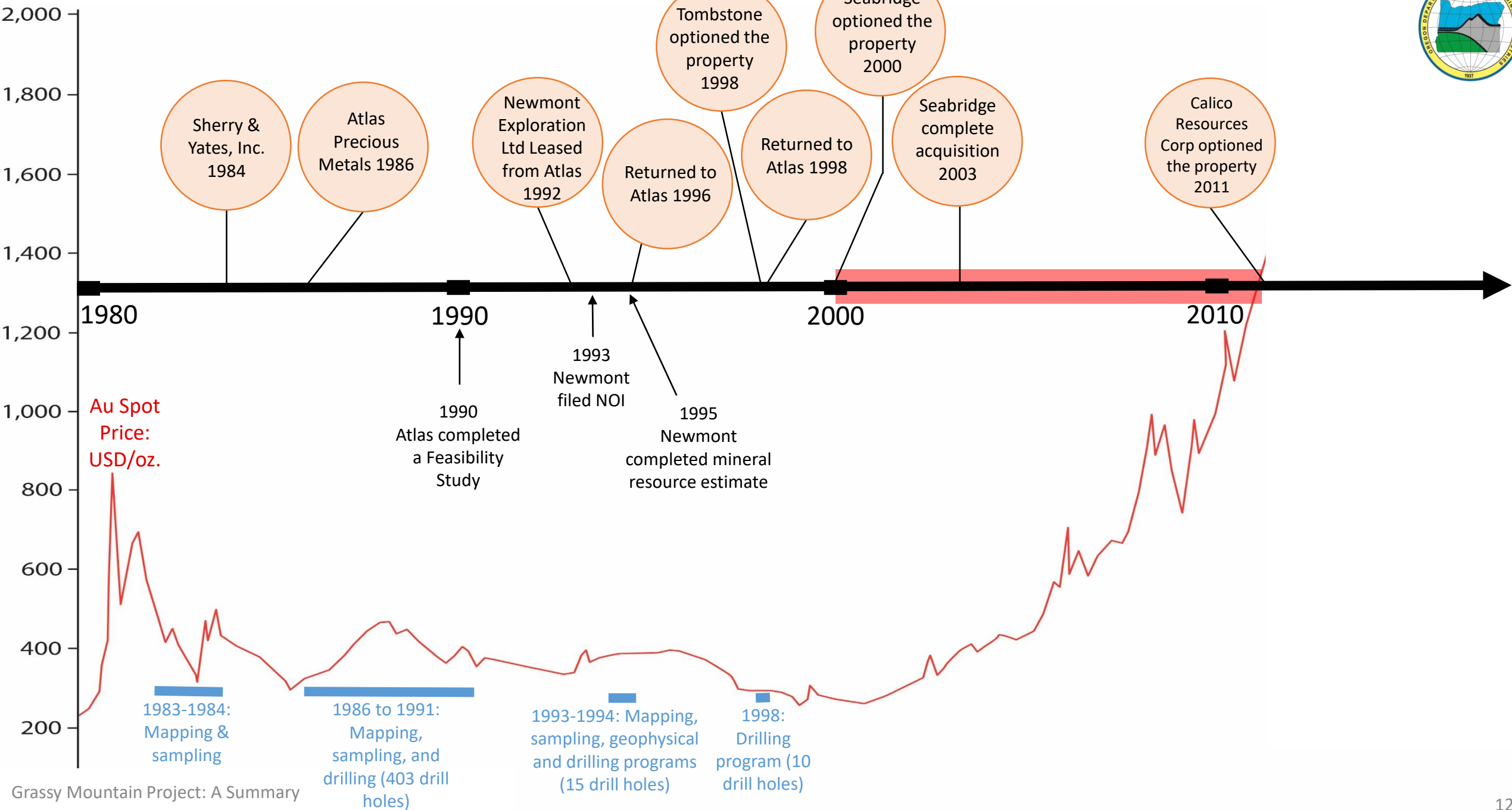
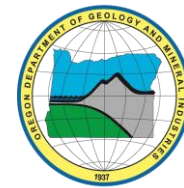

Grassy Mountain Timeline

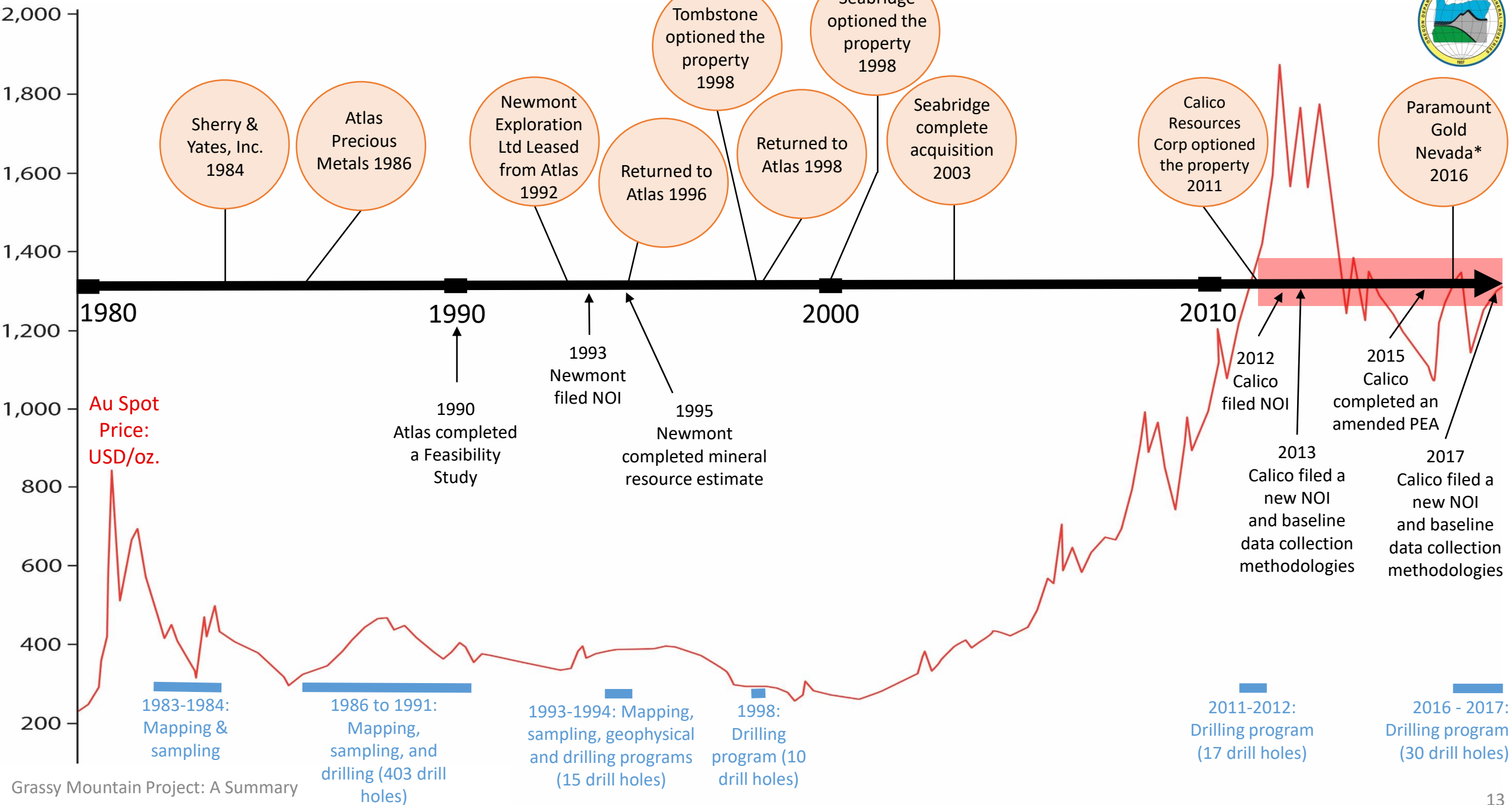

Grassy Mountain Timeline

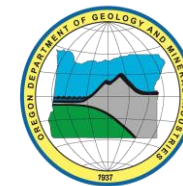

2017 NOI Boundary
Mine and Process Area: 886 acres
Access Road Area: 876 acres
Total Permit Area: 1,762 acres

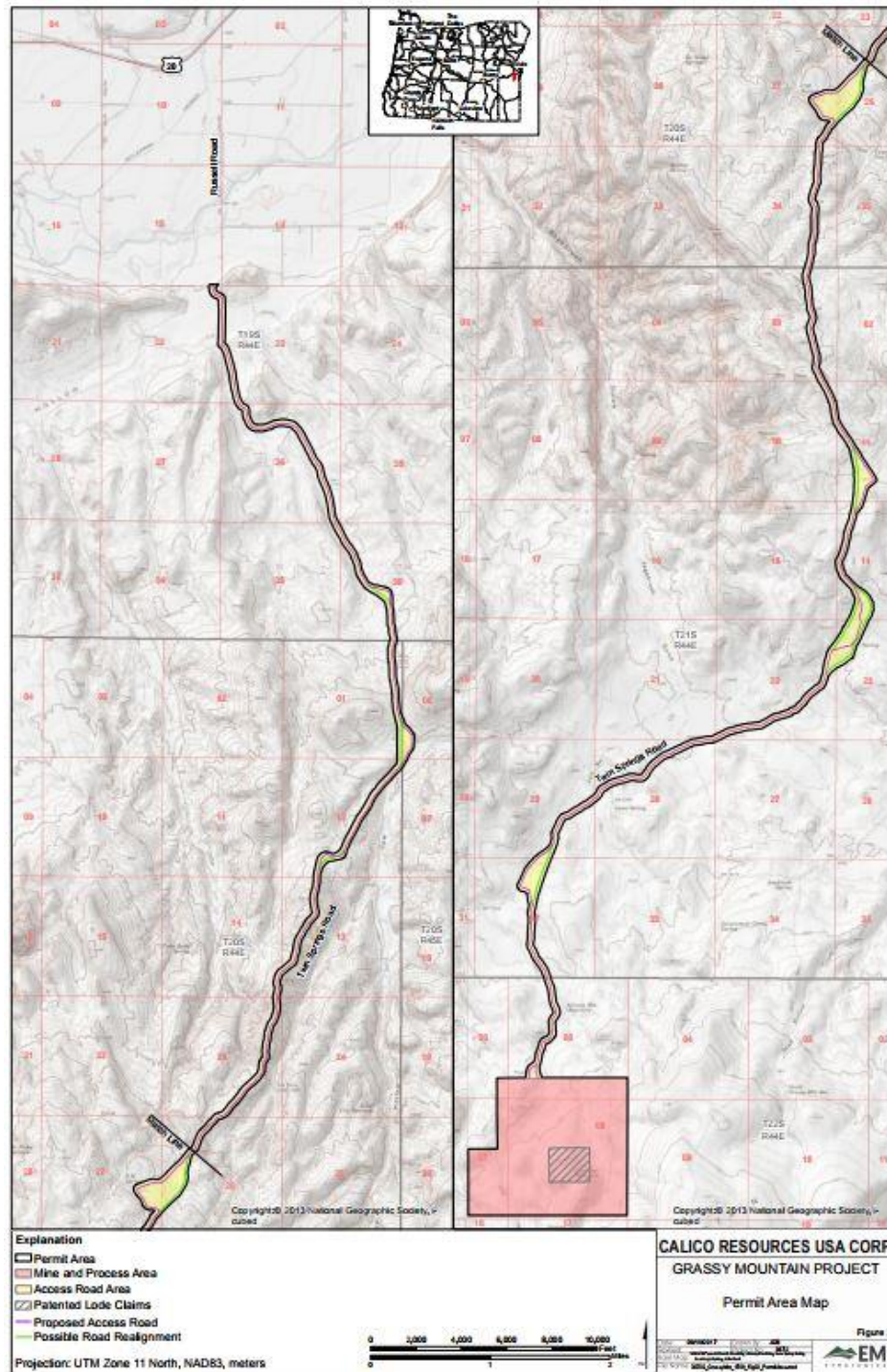

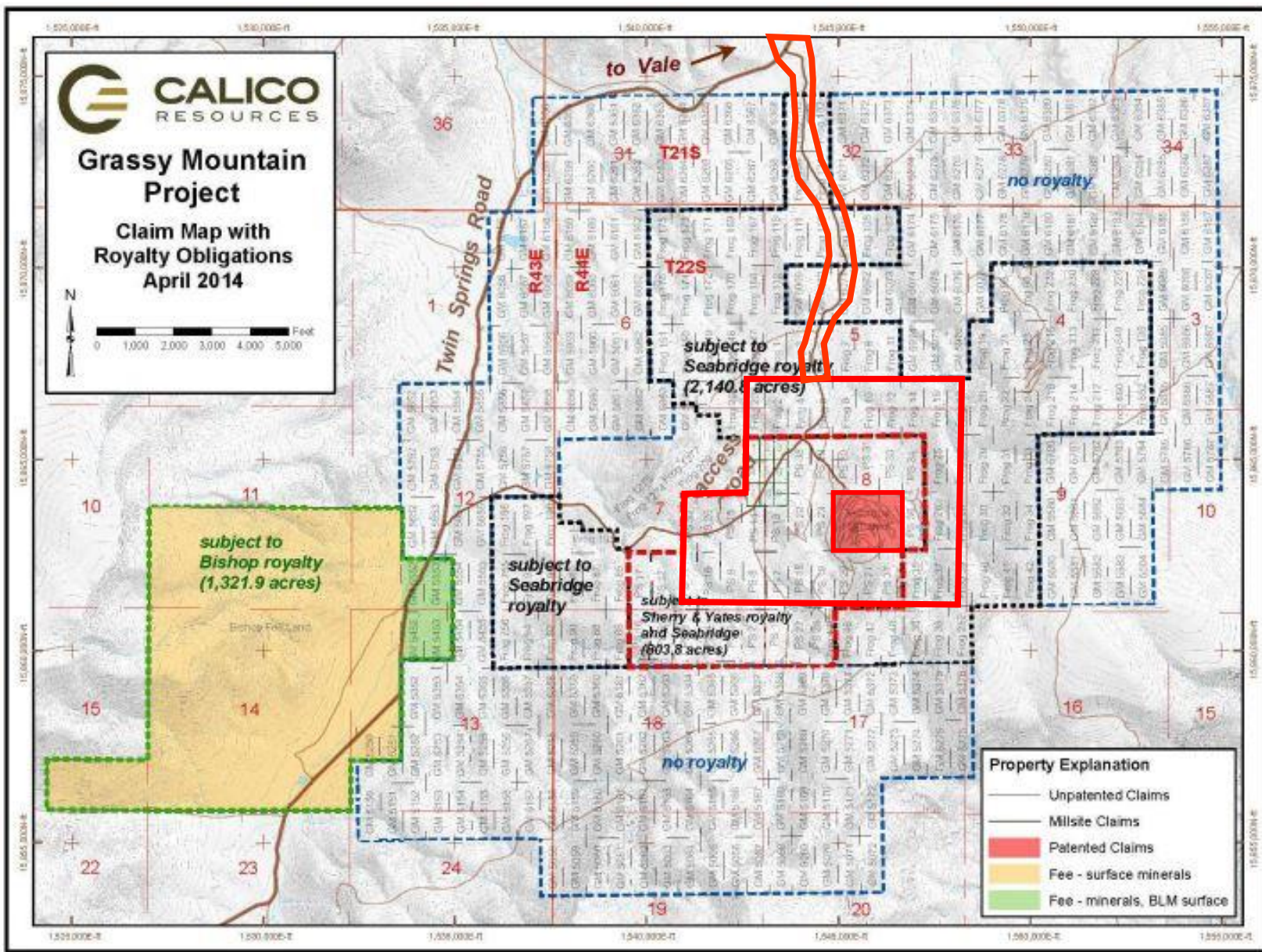
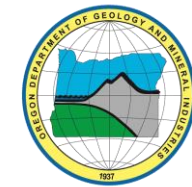

Calico reports associated claims totaling 9,300 acres

- 3 patented (private) lode claims where the deposit is located,
- 418 unpatented lode claims,
- 9 mill site claims,
- 6 associated placer claims, and
- various leased fee land surface and surface/mineral rights.

(<http://www.paramountnevada.com/projects/grassy-mountain-gold-project/>)

Figure modified from Metal Mining Consultants Inc., (2015)



Continued drilling and filed Baseline Data Collection Methodologies

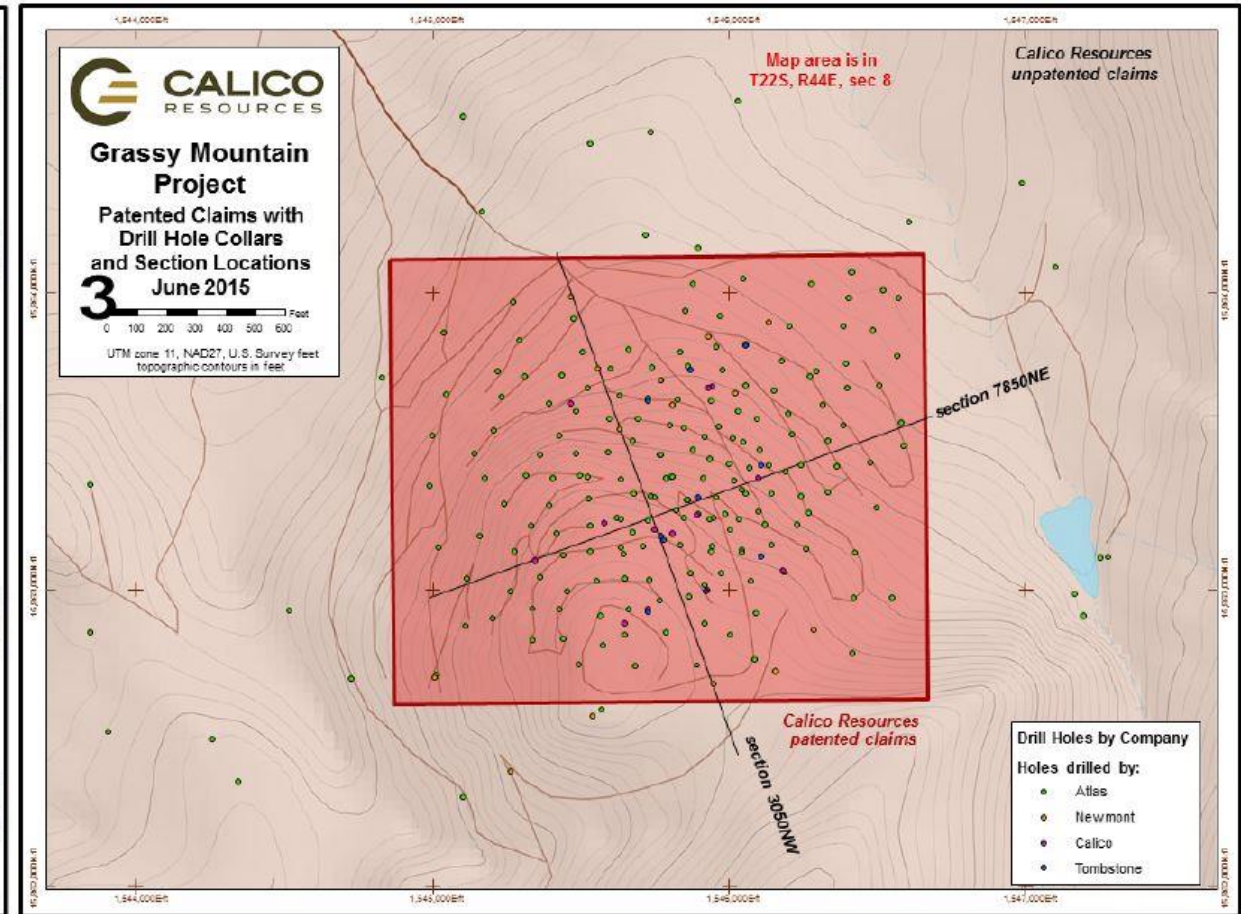
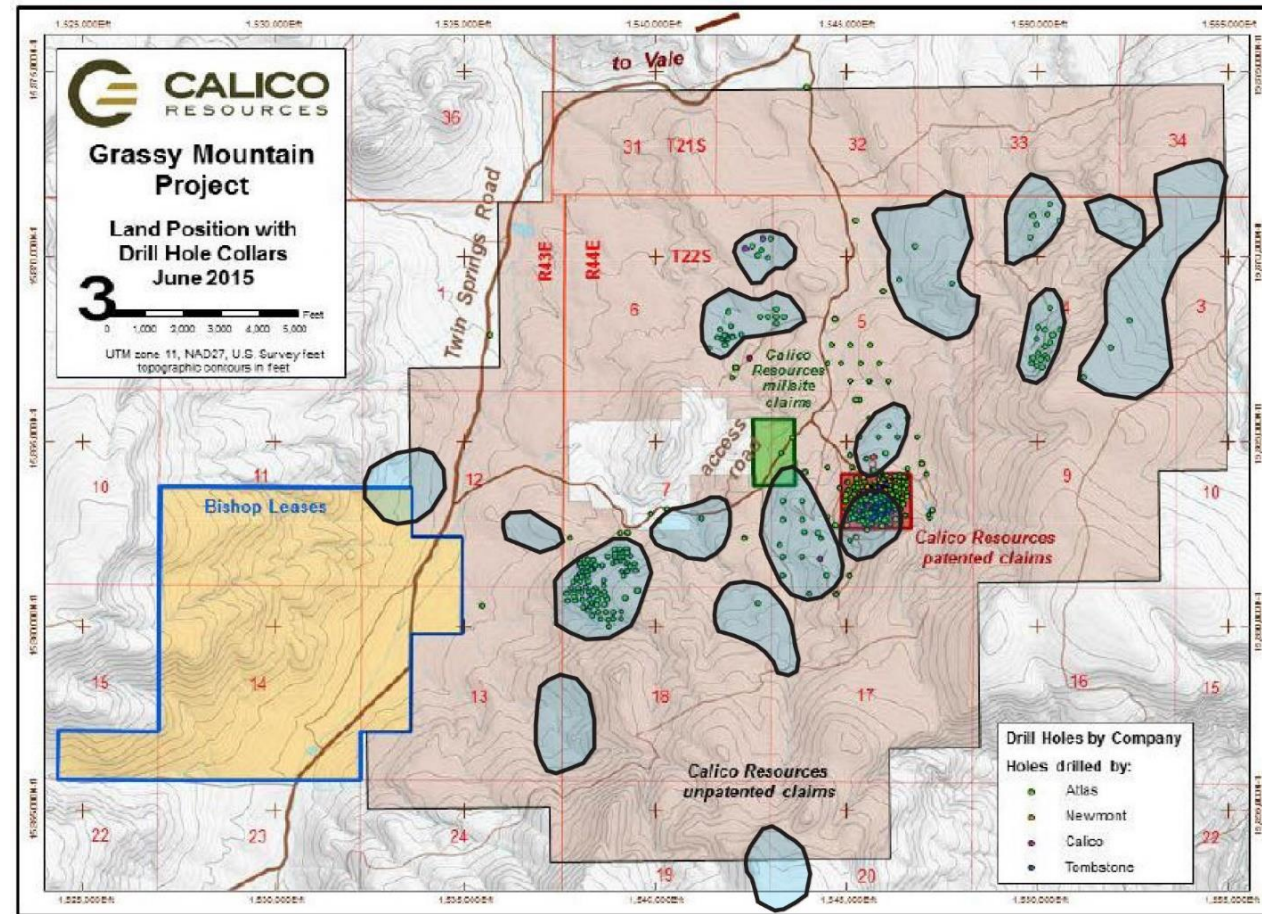

Figure modified from Metal Mining Consultants Inc., (2015)

Metal Mining Consultants Inc., (2015)

Grassy Mountain Timeline

Metal Mining Consultants Inc., (2015)

Building a detailed geologic model

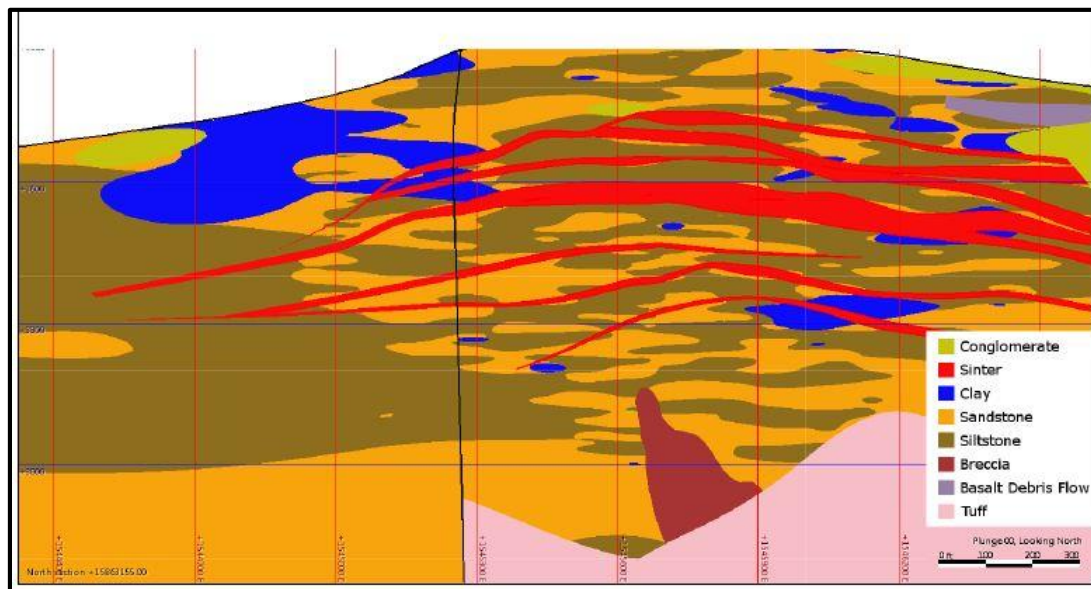

Measured					
	Tons (000s)	Au opt	Ounces Au (000s)	Ag opt	Ounces Ag (000s)
Underground (0.065 opt cog)	3,157.2	0.155	490.5	0.263	828.9
Open Pit (0.005 opt cog)	52,644.6	0.020	1,027.1	0.072	3,783.6
Indicated					
	Tons (000s)	Au opt	Ounces Au (000s)	Ag opt	Ounces Ag (000s)
Underground (0.065 opt cog)	88.3	0.149	13.2	0.163	14.4
Open Pit (0.005 opt cog)	12,802.8	0.010	121.9	0.027	349.8
Measured plus Indicated					
	Tons (000s)	Au opt	Ounces Au (000s)	Ag opt	Ounces Ag (000s)
Underground (0.065 opt cog)	3,245.5	0.155	503.7	0.260	843.2
Open Pit (0.005 opt cog)	65,447.4	0.018	1,149.0	0.063	4,133.3
Inferred					
	Tons (000s)	Au opt	Ounces Au (000s)	Ag opt	Ounces Ag (000s)
Underground (0.065 opt cog)	0.0	0.000	0.0	0.000	0.0
Open Pit (0.005 opt cog)	221.3	0.007	1.5	0.010	2.2

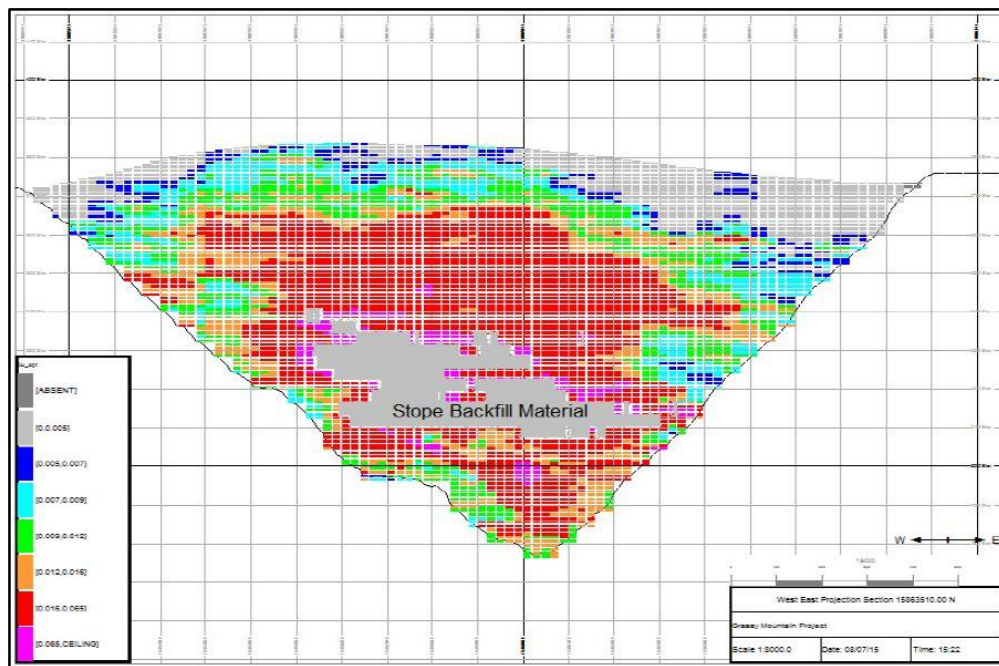

Metal Mining Consultants Inc., (2015)

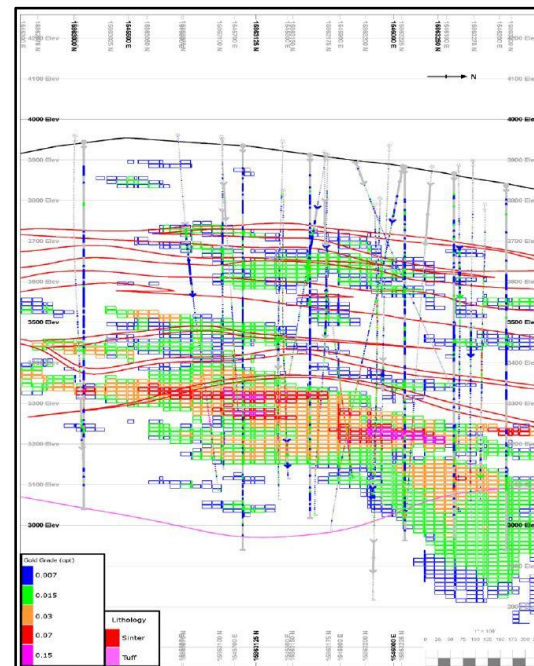

Metal Mining Consultants Inc., (2015)

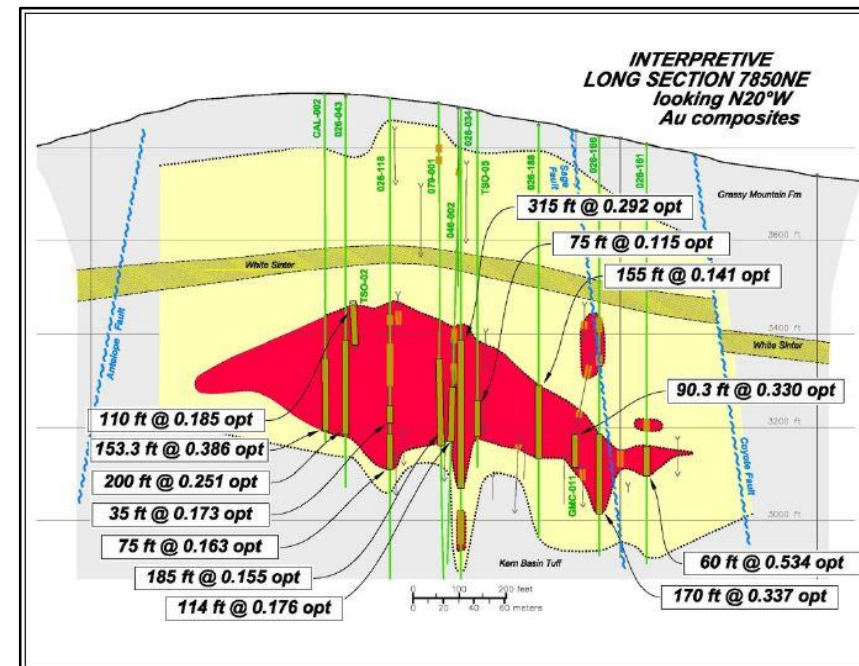

Metal Mining Consultants Inc., (2015)



A Conceptual Mine Plan and Processing Facilities

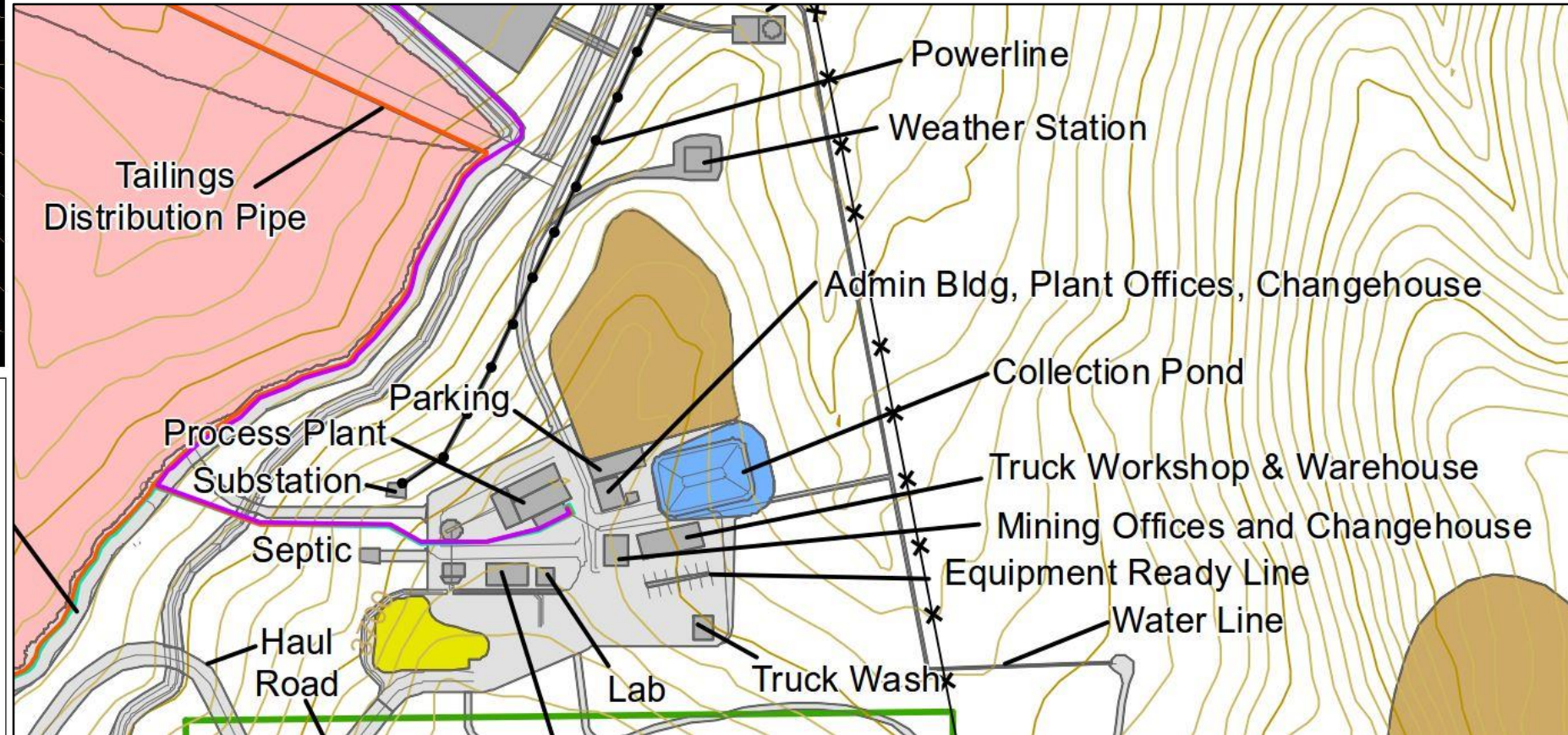
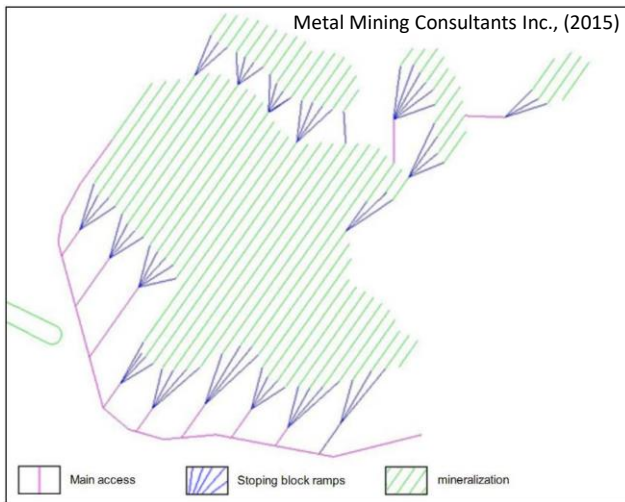

Metal Mining Consultants Inc., (2015)

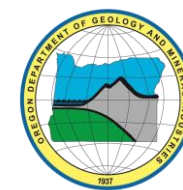

Processing Facilities (conceptual)

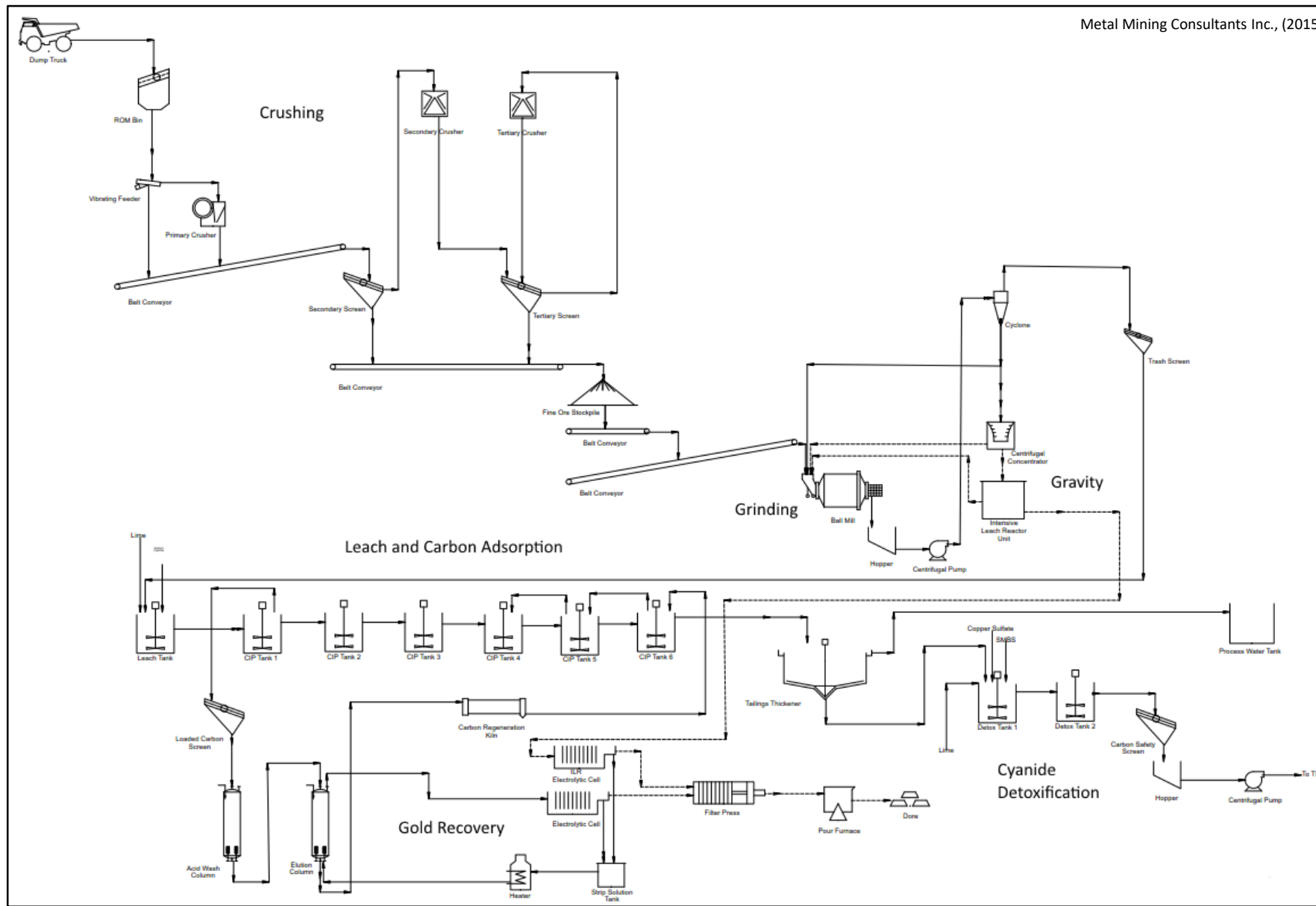

THANK YOU

References:

Metal Mining Consultants Inc., 2015, Amended Preliminary Economic Assessment Calico Resources Corp. Grassy Mountain Project Malheur County, Oregon, USA, 176 p.

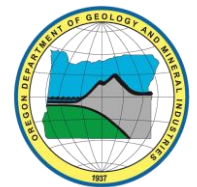

**Oregon Department of Geology and
Mineral Industries**