

Construction

General

The installation of traffic signals may consist of any or all of the following items: wood poles, mast arm or strain poles, pedestals, conduit, junction boxes, signal heads, controllers, detectors and loops, interconnects, illumination and various incidental items required to provide a properly operating signal.

Each of the following pages in this section acquaints the inspector with an area/phase of construction or type of equipment used when installing a traffic signal. The pages are loosely arranged in the order in which an inspector should encounter the subject.

Each page suggests action to be taken prior to construction, installation sequence or tips, and cautions against common pitfalls and oversights. The information given is rudimentary, so studying the appropriate section of the Standard Specifications, Special Provisions, project specific plan sheets and standard drawings is recommended prior to installation.

Illustrations have been provided to demonstrate construction practices and clarify equipment installation procedures.

ALWAYS READ THE SPECIAL PROVISIONS BEFORE BEGINNING CONSTRUCTION. The information contained within refers to modifications to the Standard Specifications or Standard Drawings and takes precedence over both.

Changes to the Plans & Specifications

Any changes made in the field are subject to the approval of the **ENGINEER OF RECORD**. The Inspector should note the changes as they occur, so that it will be easier to record these changes on the **As-Constructed** drawings. If the inspector is unfamiliar with the item being changed, he/she should talk to the Contractor, the designer, or their supervisor so they can answer any questions. This will help the inspector understand in more detail what to look for during the installation and inspection of the traffic signal, and to help reduce future costs that may occur in maintaining the signals.

ELECTRICAL SERVICE

The Project Manager coordinates with the Contractor for the electric service hook-up.

PRIOR TO INSTALLATION

- Read 00960.49
- Electrical service should be installed as shown on the project plans unless field conditions indicate otherwise.
- If relocation is required, the Inspector should consider the locations of the utility company power source, the location of underground utilities, and the location of the Controller, and then call the Engineer of Record for assistance.

INSTALLATION

- Utility companies should be notified at least two weeks in advance of the time power is needed at the site to allow them time to make adjustments or install equipment and wiring as necessary.

CAUTION-POTENTIAL PROBLEMS

- Considerable time and expense can be saved if the power source is agreed upon prior to construction. Changes made at this stage are the least expensive to incorporate into the construction plans.

TELEPHONE HOOK-UP

A telephone hook-up may be needed on your project.

PRIOR TO INSTALLATION

- Determine an EA to charge the installation/material costs to. Can be anything from the maintenance EA to a project EA.
- Need a site address for the signal controller cabinet. Could be the same as the power meter if it has a site address on the billing statement.
- Need a billing address to send the phone bills to. Typically to the Lead Region Electrician's address.

INSTALLATION

- Contact Information Systems 503-986- 3225. They will send out the TSO through DAS and contact the local phone company engineer or rep to meet on site to discuss the details.
- Meet on site. May be good to have Region Traffic and ODOT Electrician at the site visit.
- Electrical contractor to install the conduit, phone box and pull string based on site meeting. Typically, the phone company's require a 2 inch conduit.

CAUTION-POTENTIAL PROBLEMS

- There could be a cost to getting the site address but not normally be the case. Typically getting an address has been through a Public Works Department, City Hall, or the local 911 Administrator.

SIGNAL HEAD LOCATION

Head location must be established before pole layout can be finalized.

- Signal heads must be located over lanes in accordance with the Manual on Uniform Traffic Control Devices and ODOT Design Policy. The Engineer may allow 2' leeway i.e. (1' either direction)

PRIOR TO INSTALLATION

- Lay out preliminary lane lines.
- Lay out curbs and back of walk or edge of pavement
- "Roughly" locate poles from plans.
- "Roughly" locate path of span or arm
- Verify signal head alignments

INSTALLATION

- Locate lane-dimensioned head (from plans) under imaginary path of span or arm, then measure back to pole from that head using sum of dimensions from plan.

CAUTION-POTENTIAL PROBLEMS

- Lane lines on road plan or striping plan may not match lanes on signal plans, contact Engineer of Record.
- Distance back to pole may not match actual measurement to your 'rough' pole location, see pole layout.
- If these distance very consult Engineer of Record. A different design/pole size may be needed.

LOCATING SIGNAL HEADS

*40' Mast Arm total length
minus 9' total dimensions from end
equals 31' measurement to
determine pole location (center pole)*

*Adjust the pole along
this line to back of
sidewalk.(parallel to
lane line)*

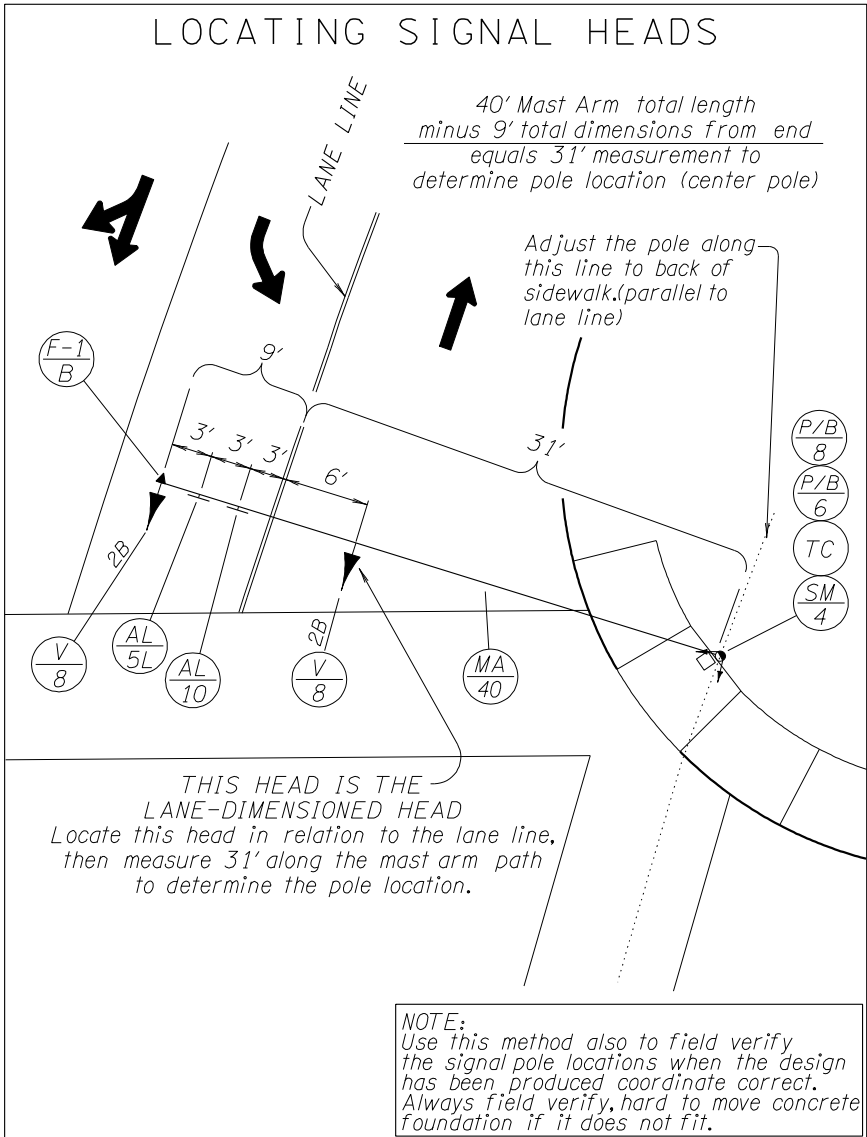

POLE LAYOUT

Pole layout is a function of field construction; poles must be field verified. Designs should be coordinate correct in regards to the base map. Final pole location may need adjustment due to utility conflicts, radius changes, striping changes, ADA walk designs, etc. Perform head location first.

- Poles should be 5' min. from face of curb.
- Poles should be 6' from edge of pavement.
- Pole islands must be raised and have a minimum area of 75 square feet.
- Poles with ped. heads on them should be in crosswalk alignment projection.

PRIOR TO INSTALLATION

- Lay out curb or edge of pavement radius.
- Lay out back of sidewalk, including ADA ramp/bypass (if such).
- Lay out raised island (if such).

INSTALLATION

- Mast arm poles can be moved parallel with the viewing traffic lanes to better fit radius, but no more than 1' either way perpendicular. (Using same arm).
- Strain poles can usually be moved any direction if necessary
- Consult Engineer of Record on any potential issues.

CAUTION-POTENTIAL PROBLEMS

- Changing pole location may require different type strain or mast arm pole.
- Changing pole location may mean auxiliary equipment (i.e. push-button posts, pedestrian pedestals, etc.) will be needed.
- Mast arms come in 5' increments, thus relocations requiring different poles and arms should be in 5' increments.
- A longer or shorter mast arm may require a different type pole and foundation.
- Major moves may affect illumination.
- Fit poles to ADA ramps, back of walk, out of bypass.

CHANGING POLE LOCATION

Note that the relationship between the lane line and the lane dimensioned head remains the same. Try to move pole parallel (in line) with lane.

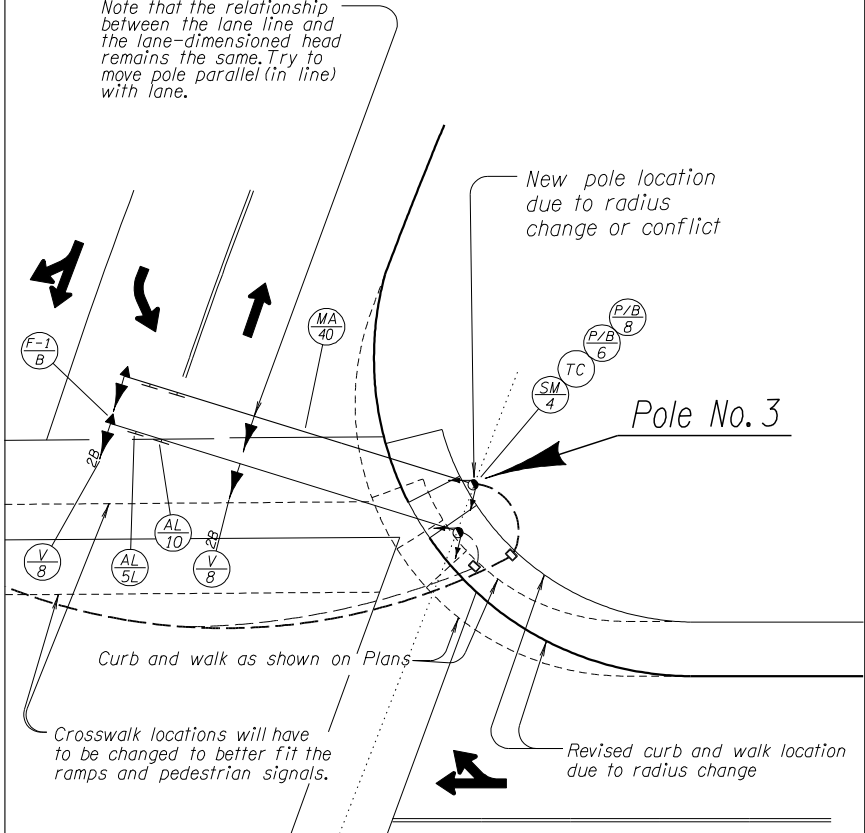

WHAT TO DO IF THE STAKED RADIUS DOESN'T MATCH THE PLAN RADIUS

JUNCTION BOX (JB) LOCATIONS

Junction box locations are approximate; changes can be made to better fit site.

- JBs are to be no more than 300' apart; intermediate JBs may not be on plans, but 300' is the maximum, unless specified differently.
- Apron type junction boxes may be installed in gravel shoulders where incidental traffic may occur.
- Only cast iron JBs in traffic areas. ie. Concrete or AC roadway surface
- Concrete JB's in concrete walks and pedestrian landings may be subject to incidental traffic.
- Do not install cast iron junction boxes for signal installations in non-paved areas or without concrete envelope in paved areas.

PRIOR TO INSTALLATION

- Read 00960.44, TM472, TM480, Special Provisions.
- Layout curb radius, concrete walk, crosswalks and wheelchair ramps.
- Layout edge of pavement and pedestrian landings in non-curbed sections.
- Layout approximate location of detector loops.

INSTALLATION

- Stake JBs relative to locations on plans.

CAUTION-POTENTIAL PROBLEMS

- Compare signal plans to Roadway plans (or existing facilities) and verify JB type (see Junction Box Section).
- Concrete JBs in pedestrian landings should be located by pole, away from edge of pavement, or installed with a concrete apron.

CHANGING JUNCTION BOX LOCATIONS

NOTE:
Plans originally called for edge of pavement, but were later changed to a curb and sidewalk section.

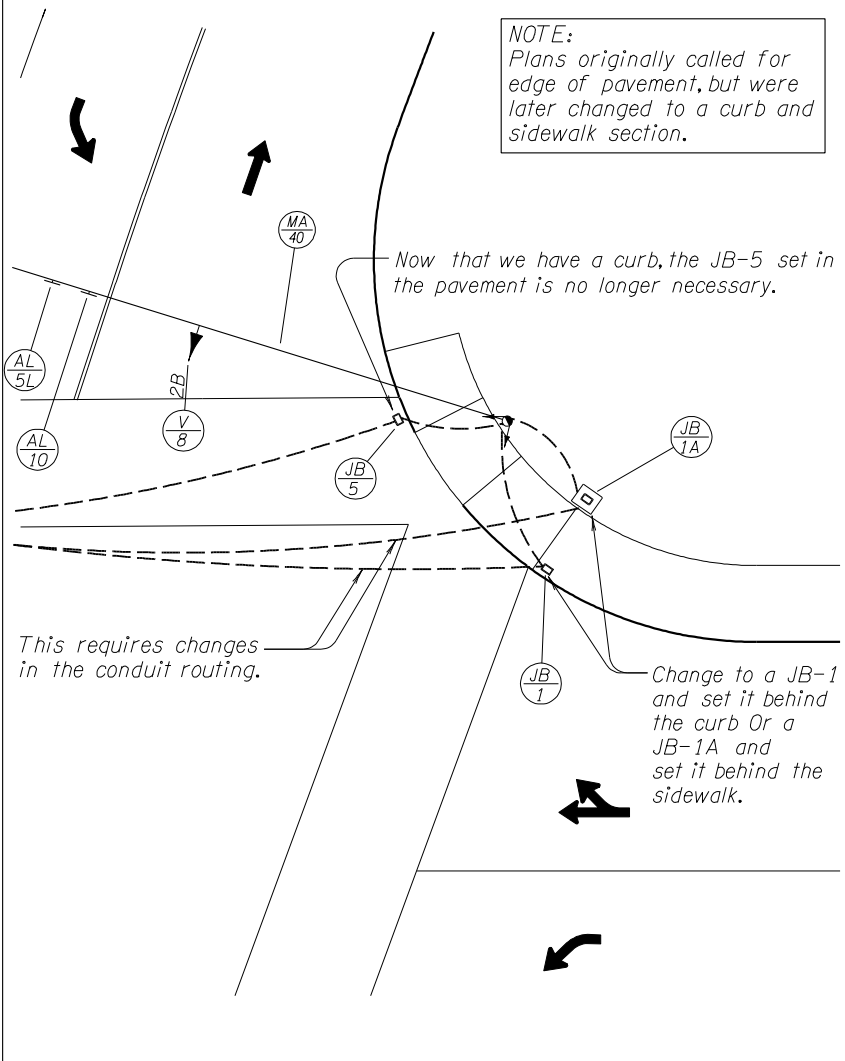

POLE AND PEDESTAL FOUNDATIONS

Pole and pedestal foundations are poured against undisturbed material, some minor back-fill is allowed with well compacted materials.

- Most pole foundations are 36"-42" square.
- Depth varies according to pole type and site conditions which will be shown in the project plans.
- Vehicle pedestal foundations are 3' (min.) square x 4' (min.) deep. See TM457.
- Pedestrian pedestal foundations are 2' (min.) square x 3' (min.) deep. See TM457

PRIOR TO INSTALLATION

- Read 00962.43, 00963, TM450, TM452, TM457, TM458, TM650 thru TM 653, TM660, TM661
- Verify location and finish grade before excavating.
- Determine anchor rod alignment.
- Inspect poles for damage or defects. Measure anchor rod diameter & rod circle of pole.

INSTALLATION

- Inspect cage for bar size, ties, and clearance.
- Verify correct number and sizes of FIBERGLASS conduit bends are installed and bundled at top.
- Conduits are not to be spliced/coupled at foundation edge.
- Inspect anchor rods for diameter, length, and proper alignment in template.
- Foundations are constructed with one continuous concrete pour, except for 4" pad at top.
- Ground rods must be outside of foundation for mast arm and strain poles.

CAUTION-POTENTIAL PROBLEMS

- Steel cage and template can be displaced by pour or vibratory equipment.
- Improper anchor rod alignment may cause rejection of foundation.
- Temp. casings used during construction must be removed.
- All conduits in foundations FIBERGLASS.
- Put spacers between conduits when bundling to allow for bushing installation later.

POLE AND PEDESTAL FOUNDATIONS

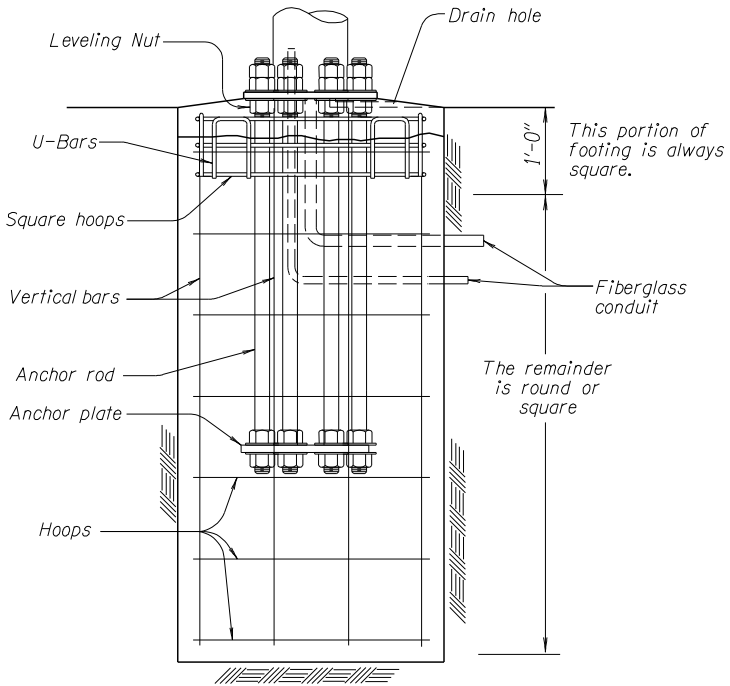

NOTE:
Pour against undisturbed material or backfill with well compacted material. Continuous pour except for the last 4" closure pour.

TYPICAL FOOTING FOR SIGNAL POLES

Rebar Size Number: Each number equals 1/8"
So a #5 bar is 5/8"

TRENCHING FOR CONDUIT

Trenching for conduit shall be accomplished in the general pattern shown on the plans. Actual location of conduit runs may vary as necessary to avoid obstructions. Runs should be straight as possible without crossing loop locations. Most trenching will be done with a backhoe. It also may be done with a trencher, but care must be taken to provide proper backfill of a narrow trench. Some conduits may be installed by horizontal directional drilling so as not to disturb the existing roadway and traffic. If horizontal directional drilling is not under roadway, 'Buried Conduit' marker posts may be required, due to marking tape not being installed over the conduit in the trench.

- Utilities shown on plans are approximate. Always.

PRIOR TO INSTALLATION

- Read 00960.41
- Utilities shown on plans are approximate. Always request a 'locate' before trenching.
- Lay out all poles, JB's and controller before trenching.

INSTALLATION

- Trench adequate depth to provide minimum cover for conduit, as spelled out in Section 960.41(c) of the Standard Specifications.
- Saw-cut pavement before trenching. A pavement saw must be used.
- Hold trench width to a practical minimum.

CAUTION-POTENTIAL PROBLEMS

- Un-located utilities (expensive and dangerous).
- Check local jurisdictions to ensure that greater trench depths aren't required.
- 'Hand-trenching' may be necessary in landscape, irrigated areas, under curb lines or for utility conflicts.

TRENCHING FOR CONDUITS

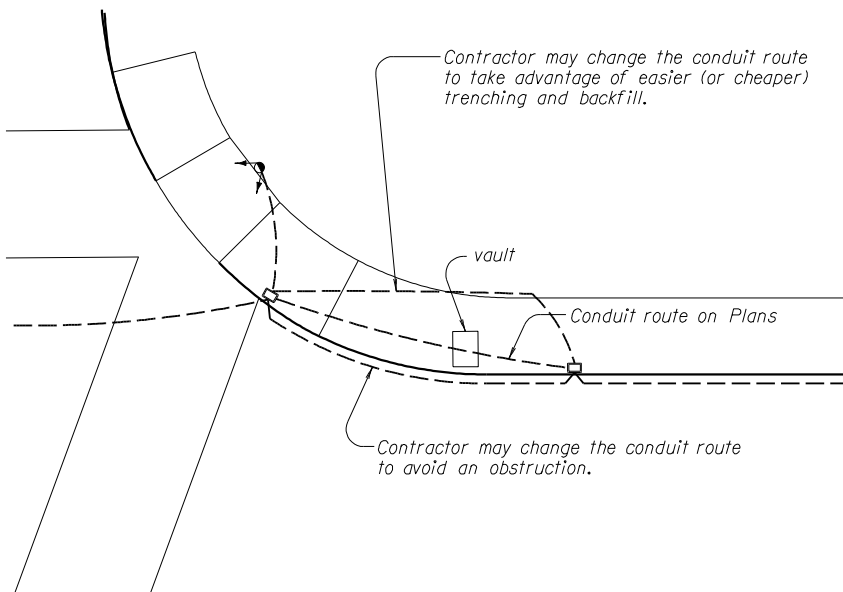

CONDUIT ROUTING IS ONLY SCHEMATIC

NOTE:

Standard specifications 00960.41 (a) requires that all excavations in paved areas be cut to a depth of at least 2" with an approved pavement saw. An "Earth Saw", "Conduit Wheel", etc., will not be approved. The conduit trench edges shall be sharp, well-defined with no evidence of cracking or stressing.

Conduit crossings of existing pavement may be required to be drilled. This is so that the conduit installation will not disturb the existing surfacing and traffic.

CONDUITS

Conduits approved for use on signal projects are non-metallic (PVC, HDPE, and Fiberglass) and galvanized rigid metal conduit.

- Conduit must be same size outlet-to-outlet (no reducers).

PRIOR TO INSTALLATION

- Read 00960.42, 002920.10-.11-.12, Special Provisions.
- Place 2" sand bedding in bottom of trench before laying PVC conduit unless CLSM is to be used.
- Smooth bottom of trench for metal conduit.

INSTALLATION

- Rigid metal conduit must be reamed and threaded and joined with a coupling. Coat threads with rust preventative compound.
- PVC conduit ends must be clean, dry, primed, and free of burrs before cementing.
- The contractor has the option to increase the conduit size for their convenience. (At no extra cost to the Agency)
- Conduit elbows must be FIBERGLASS. See 00960.42(f).
- Risers in junction boxes are PVC.

CAUTION-POTENTIAL PROBLEMS

- In corrosive soils, plans & specs. will call for coated or wrapped metal conduit. (Also around high voltage electrical devices, i.e. MAX in Portland)
- See Standard Specifications for HDD rules.
- See National Electrical Code for conduit type requirements not specified by plans.
- Conduit for future use shall be installed with polyethylene pull line, and capped.
- Conduit must be installed by licensed Electrician.
- Conduit **MUST** be inspected by Region Electrician before backfill (see 00960.42(e)).

INSTALLING CONDUITS

Minimum practical width to allow for compaction

Match existing surface thickness

4" min.

Concrete backfill required (CLSM mix as per 00442)

Match existing surfacing depth

2" sand layer above and below PVC conduit is REQUIRED.

Paved Areas Under Traffic

Unpaved Areas or Non-Traffic Paved Areas

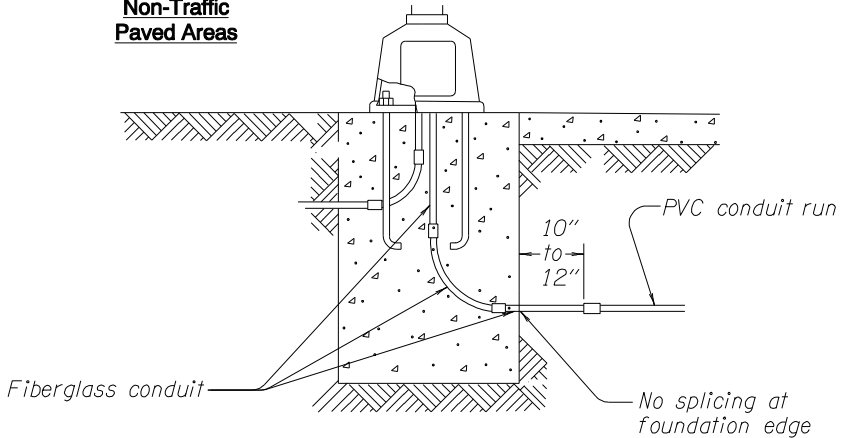

CONCRETE or POLYMER CONCRETE JBs

Concrete or polymer concrete JBs are open-bottom boxes installed in sidewalks, in gravel shoulders (with apron), behind curbs in landscaping, behind guardrail, or in A.C. pedestrian landings.

- Do not install in traffic areas.
- Do not install in gravel shoulders. (Unless plans call for apron type).
- Must be fitted with galvanized cast iron, galvanized steel, or cast aluminum, or concrete polymer recessed lid, loading rated for incidental traffic.
- Lids are held down with two stainless steel or brass bolts and nuts.

PRIOR TO INSTALLATION

- Read 00960.44, 002920.14 and TM472.
- Determine finish grade for top of JB.
- Excavation for JB must be adequate for 12" (min.) depth of $\frac{3}{4}$ " – 0" gravel bedding.
- All FIBERGLASS conduit bends and PVC risers must enter box from underneath and be concentrated at either end of box.

INSTALLATION

- Place box on bedding, backfill sides with well compacted material.
- Verify finish grade.
- Locate box at back of curb.
- Bond metallic lid if 120v + power is present.

CAUTION-POTENTIAL PROBLEMS

- Be sure junction box is not resting on conduits.
- Junction boxes with common conduit runs are to be spaced no more than 300' apart.
- Marked with post and paddle were appropriate (see 00960.44(b) and TM570).
- Have appropriate lid with appropriate label. (Traffic Signals, Communications, Street Lighting or power)

CONCRETE JUNCTION BOX INSTALLATION

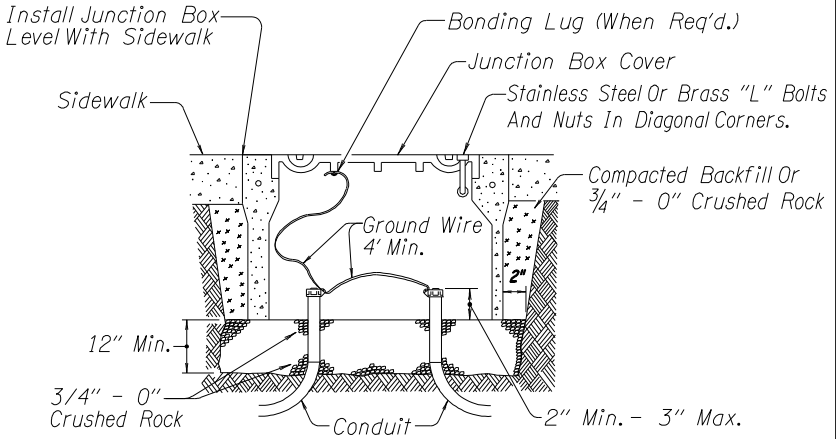

INSTALLATION IN SIDEWALK OR AT BACK OF CURB

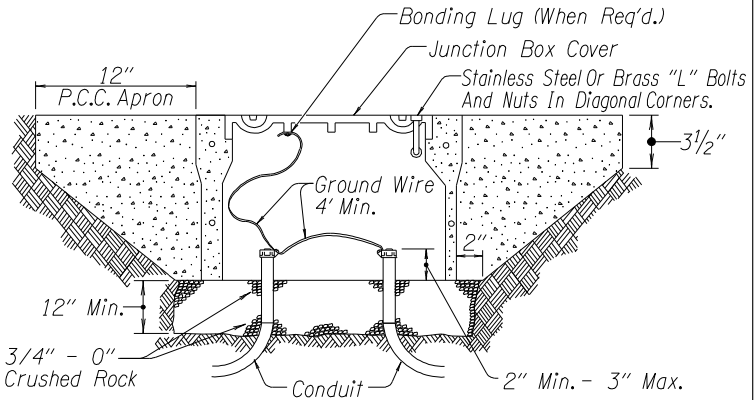

INSTALLATION WITH PORTLAND CEMENT CONCRETE APRON

(For Incidental Travel Areas Only; Gravel Shoulders, Behind Guardrail, Etc.)

CAST IRON JUNCTION BOXES

Cast iron junction boxes are sealed, gasketed boxes installed in traffic areas, or in paved shoulders. Fitted with gasketed steel cover. For traffic areas lids shall be recessed type and for surface mount they shall be overlapping type.

- Cover held down with stainless steel cap screws or Hex bolts.

PRIOR TO INSTALLATION

- Read 00960.44, 02920.14 and TM480.
- Determine finish grade for top of JB. In pavement areas leave box down 1/4" from finish grade.
- JB must be a minimum of 12" from E.P. or curb.
- Provide 6" of bedding and 4" of Portland Cement Concrete under JB.
- Provide 4" of PCC Concrete on all sides of JB. A.C. will not provide adequate support. (Street boxes for loop wire entrances may also be install by this method)

INSTALLATION

- Drill bottom of box for conduit entrances.
- Install metal conduit bends/risers into JB using malleable iron conduit hubs.
- Verify finish grade and secure JB in place during concrete pour around box.
- Finish concrete, sloping up 1/4" to finish grade.

CAUTION-POTENTIAL PROBLEMS

- JBs installed without PCC concrete envelope will break conduit ends and sever conductors. Must be Portland Cement Concrete not Asphalt Concrete.
- 5/8" drain conduit must be imbedded into gravel bedding in order to function. (No drain conduit in street box).
- Junction boxes with common conduit runs are to be spaced no more than 300' apart.
- To prevent sloughing of roadway, do not install JB's within 12" of top of slope.

CAST IRON JUNCTION BOX INSTALLATION

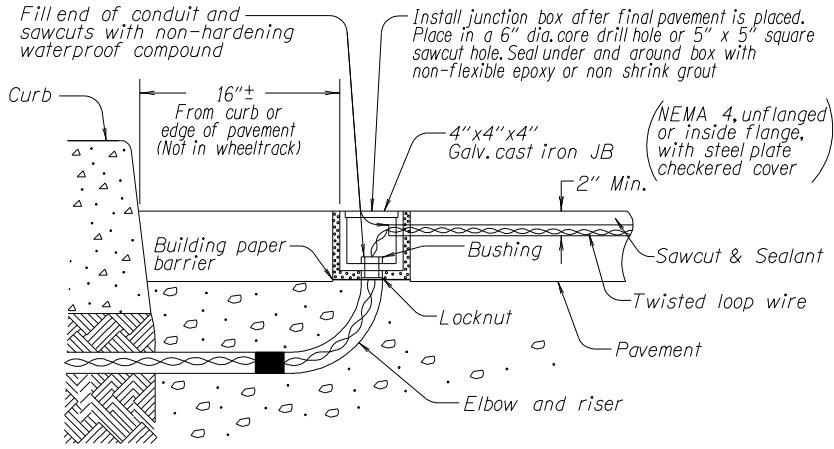

STREET BOX (Loop Wire Entrance)

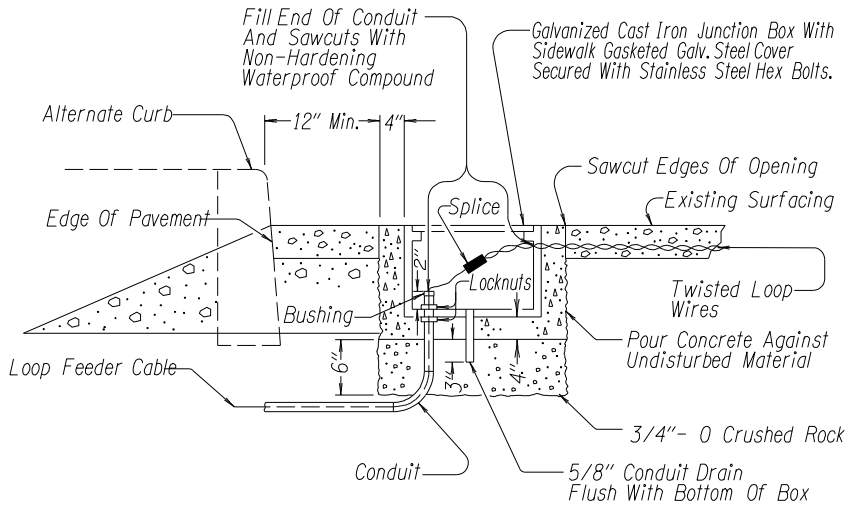

GALVANIZED CAST IRON JUNCTION BOX INSTALLATION IN PAVEMENT

CONDUIT TRENCH BACKFILL

Conduit trench backfill under pavement can be accomplished with either compacted selected granular material (paved non-traffic) or CLSM (controlled low strength material) backfill (traffic areas). Trenches outside of paved areas can be backfilled with compacted selected general (native) material free of clods and rocks.

CONDUIT CROSSINGS MAY BE REQUIRED TO BE HORIZONTAL DIRECTIONAL DRILLED (TRENCHLESS INSTALLATION)

PRIOR TO INSTALLATION

- Read 00960.41, 00960.42 & Special Provisions.
- PVC conduit to be backfilled with granular material or native material must have 2" sand bedding and 2" sand cover.
- PVC conduit to be backfilled with CLSM needs no bedding.
- CLSM BACKFILL IS REQUIRED IN ALL EXISTING TRAFFIC AREA (ROADWAY & SHOULDER) TRENCHES.

INSTALLATION

- Backfill and compact in 6" layers up to 6" below finish grade.
- Place underground marking tape in ALL TRENCHES NOT using CLSM for backfill.
- CLSM backfill requires little compaction and no underground marking tape.
- Finish final 6" to match surrounding surface.

CAUTION-POTENTIAL PROBLEMS

- Contractor should be cautioned "Do not cover conduit runs until inspected" as required by 00960.42(e).
- Make sure that at least one trench/backfill is inspected by an Agency Electrician.
- Make sure conduit doesn't 'float up' when using CLSM backfill.
- Plug all conduit ends during backfill operation, to keep debris from entering conduit. Keep plugged until wire is pulled.

BACKFILLING TRENCHES

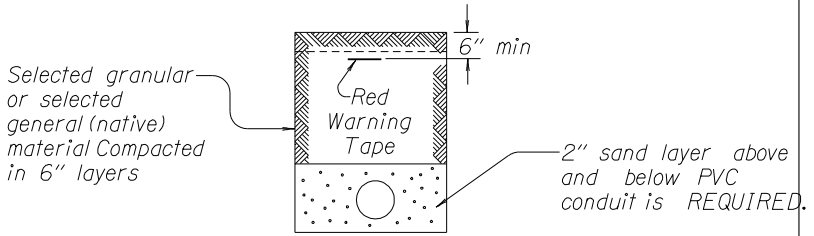

Unpaved Areas or Non-Traffic Paved Areas

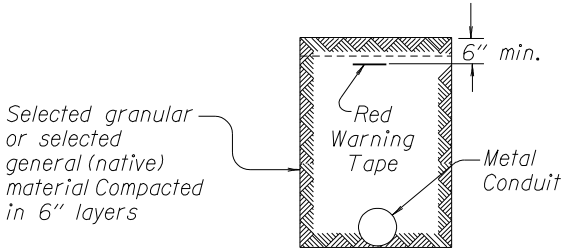

Unpaved Areas or Non-Traffic Paved Areas

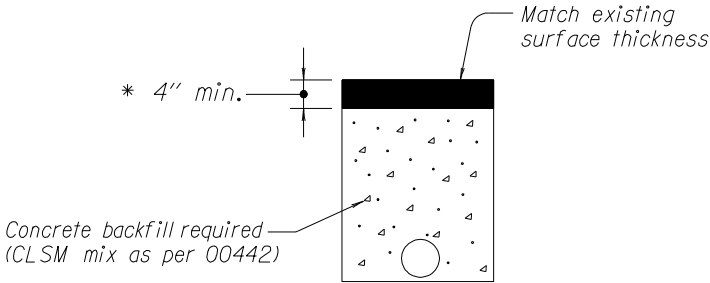

(Smooth Bottom) PVC or Metal conduit Paved Traffic Areas

BONDING AND GROUNDING

Bonding and grounding is typically necessary for all conduits with 120+volt A.C. conductors and ground rod shall be installed for all major equipment. The ground rod may be located in an adjacent pull box.

- Bonding & Grounding can get rather complicated so this is one area where requesting assistance from Agency Electricians is **STRONGLY** suggested.
- Generally a bond wire is necessary in most conduits.
- Bonding is not required in a non-metallic junction box with non-metallic lid since the elbows, risers, and bushings are all non-metallic.
- Bonding is required in a metallic junction box or with metallic lids if there is any 120V+ circuits in the box.

PRIOR TO INSTALLATION

- Read 00960.50, TM450, TM452, TM455, TM457, TM472, and TM485
- Identify which conduits will have 120+A.C. circuits and which will have only low voltage circuits.
- Choose appropriate location for ground rods at all poles, pedestals, and cabinets.

INSTALLATION

- Install bonding lugs on conduits were needed.
- Drive ground rods, attach #6 AWG ground wire to rod and grounding lug. Bond conduit to ground rod if needed.
- Bond metallic JB lids to conduit bonding lug (if 120+AC power present) with adequate length to remove cover.

CAUTION-POTENTIAL PROBLEMS

- Remember to connect bond wires to conduit bonding lugs when conductors are pulled.
- Ground rods must be installed in minimum JB/1's. On wood poles, all equipment less than 8' above ground shall be bonded at each pole as per T.M.S. Dwg. TM455.
- All ground and bond wires must be stranded conductors

BONDING AND GROUNDING

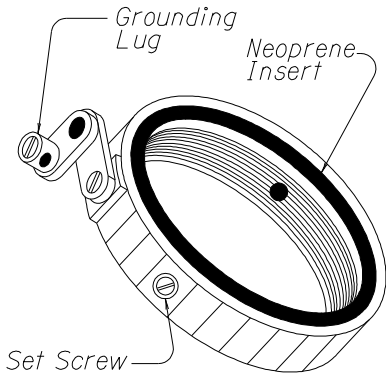

METALLIC BUSHING WITH BONDING LUG
(shall not be aluminum)

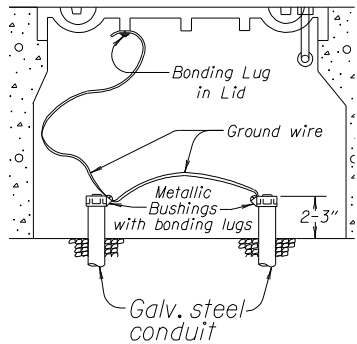

JUNCTION BOX GROUNDING AND BONDING

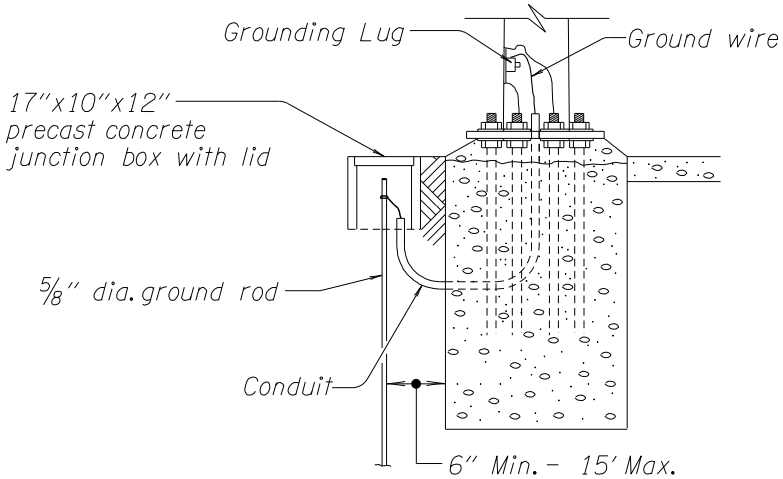

POLE FOUNDATION GROUNDING AND BONDING

PULLING WIRES AND CABLES

Pulling wires and cables is always done by hand, using approved lubricants when inserting conductors into conduit.

- Do not use any mechanical means to apply or multiply pulling force.
- Do not tie or tape conductors or cables together inside conduit.

PRIOR TO INSTALLATION

- Read 00960.45.
- Be sure all insulated conduit bushings (with or without) bonding lugs are installed before pulling wires.
- Be sure bond wire is included with wire and cables (if required).

INSTALLATION

- Always pull wires and cables in a straight line with the conduit opening, using a pulley device if necessary to achieve a straight line.
- Use approved lubricant to reduce pulling strain and prevent insulation damage.
- Requires one person pulling the wire and one person feeding the wire in the conduit.

CAUTION-POTENTIAL PROBLEMS

- Be sure conduit is clean and dry before pulling wires.
- Inspect pulled ends of conductors for insulation damage, replace if damage is discovered.
- No splicing is allowed outside of terminal cabinets except loop wire to feeder cable splices in junction boxes.

PULLING WIRE AND CABLE

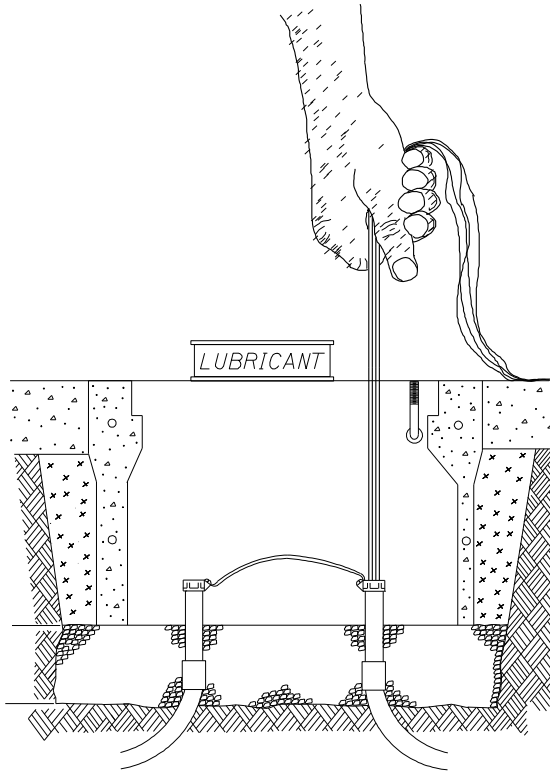

NOTE:

**THIS IS THE ONLY APPROVED
METHOD FOR PULLING WIRES
AND CABLES THROUGH CONDUIT!**

WOOD POLES

Wood poles are normally used as strain poles for temporary signal installations. See TM455 for details.

- Wood poles may be used for temporary power service for signal installations.

PRIOR TO INSTALLATION

- Read 002120.10.
- Inspect poles for splits or in-transit damage.

INSTALLATION

- Locate utilities before drilling holes.
- Verify setting depths.
- Rake pole away from the applied load.
- Install anchors opposite the applied load.
- Backfill around pole with granular material.
- ALL wiring on pole shall be in a conduit.

CAUTION-POTENTIAL PROBLEMS

- Bond all equipment within 8' of finish grade at each pole.

WOOD POLES AND ANCHORS

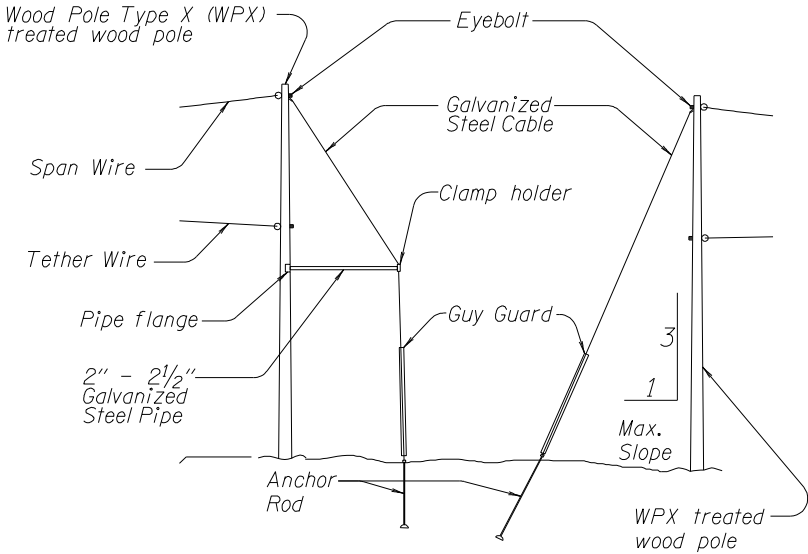

Anchor Cone

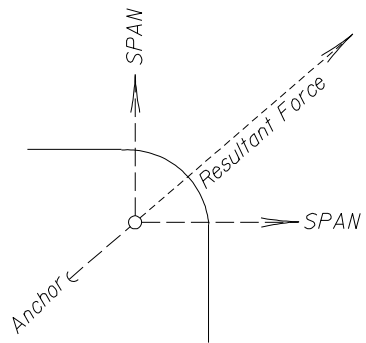
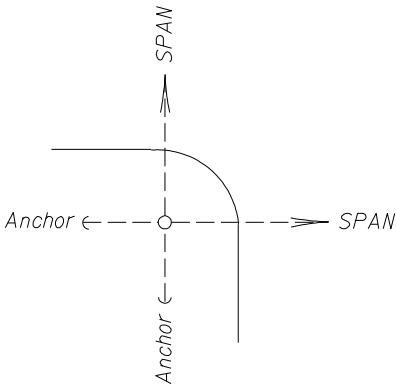

STRAIN POLES

Strain poles are tall 30' ± galvanized steel poles to which spans are attached. These spans suspend signal equipment over the roadway.

- Concrete foundations require 7 days minimum of cure before pole shafts can be erected. Don't load pole until foundation reaches design strength. See 00962.43 then Table 00540-1. Break concrete test cylinders to verify see 00440.

PRIOR TO INSTALLATION

- Read 00440, 00962, TM660, TM661.
- Check pole tag for proper information.
- Inspect pole welding & 'thredolet' welding.
- Check for wire hanger hook and grounding lug.
- Repair galvanizing damage from handling.
- Install eyebolts and pole cap.

INSTALLATION

- Install leveling nut & washer on anchor rods.
- Install top washer & nut, rake pole to counteract load using leveling nuts.
- Pour Grout (concrete) pad with weep hole, 3/4" pole drain.

CAUTION-POTENTIAL PROBLEMS

- Tighten anchor rods according to 00962.46(j)
- Poles and arms can be round or octagonal but two types shall not be mixed on project.
- Reinstall handhole cover until wiring can be completed.

STRAIN POLE ATTACHMENTS

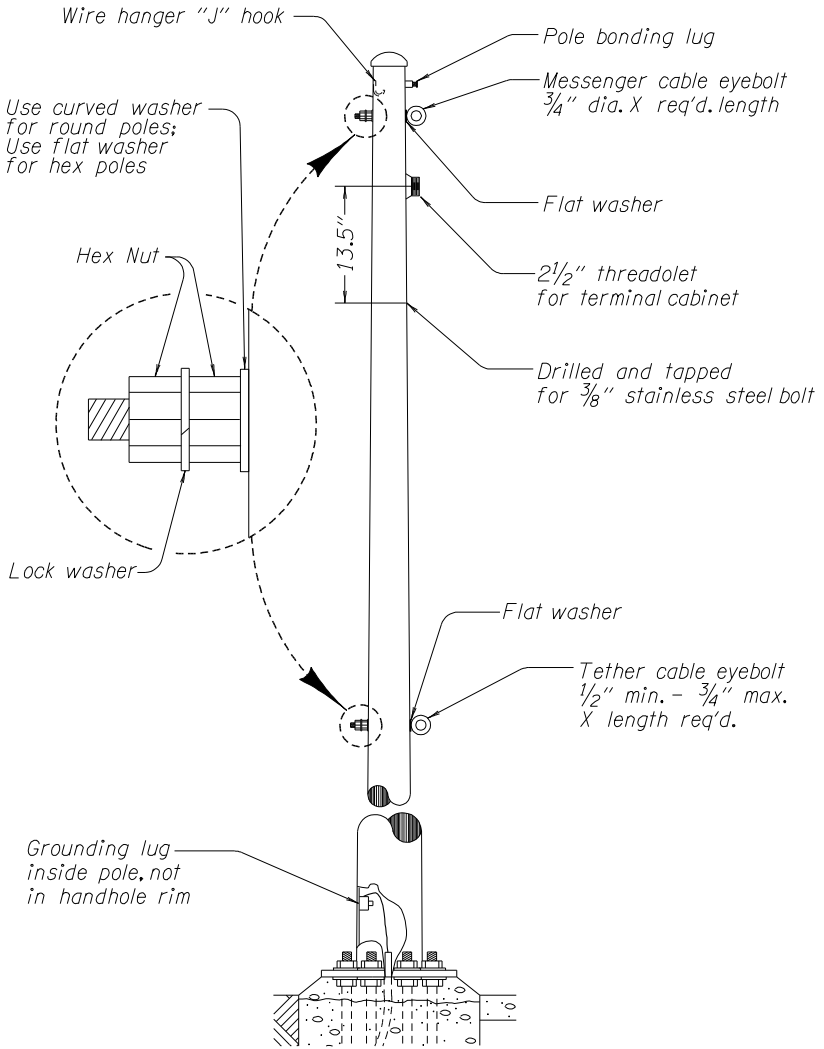

MAST ARM POLES

Mast arm poles are relatively short 20'± poles with cantilevered arms used to support signal equipment over the roadway.

- Concrete foundation requires 7 days of cure before pole shaft can be erected. Don't load pole until foundation has reached design strength. See 00962.43 then Table 00540-1. Break concrete test cylinders to verify see 00440.

PRIOR TO INSTALLATION

- Read 00440, 00962, TM650, TM651, TM652, TM653.
- Check pole tag for proper information.
- Inspect pole welding.
- Check pipe sleeve at mast arm mount for proper rounding.
- Check for wire hanger hook and grounding lug.
- Repair galvanizing damage from handling.

INSTALLATION

- Install leveling nut and washer on anchor rods.
- Install top washer and nut, rake pole to counteract load using leveling nuts.
- Pour concrete/grout pad with weep hole, 3/4" pole drain.

CAUTION-POTENTIAL PROBLEMS

- Tighten anchor rods according to 00962.46(j)
- Poles and arms can be round or octagonal, but two types shall not be mixed on a project.
- Reinstall hand-hole cover until wiring can be complete.
- Verify signal head and sign clearances. May require different mounting from plan. (Due to manufacturers arm upsweep angle variances.)
- Check for mast arm mounting plate fit/bolting. (plate warp or bolts not seating)

MAST ARM POLES

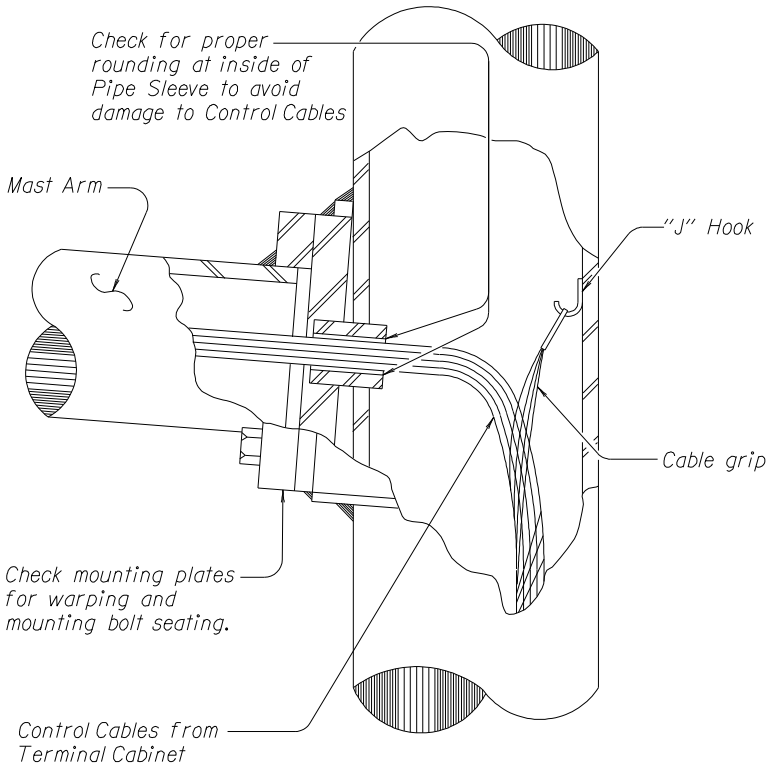

TERMINAL CABINETS

Terminal cabinets are mounted on poles and used for converting single conductors to control cables on mast arm and strain poles, or multiple conductor control cables to multiple smaller control cables on a span.

- Size 18"x8"x6"

PRIOR TO INSTALLATION

- Read 00990.41, 02925.40, TM488.
- Check galvanizing and/or powder coating.
- Check for 3 lines of brackets for single sectional terminal blocks (quantity & size as needed).
- Check pole for thredolet and that lower mounting hole has been drilled & tapped.

INSTALLATION

- Mount to pole with close nipple into factory installed thredolet and conduit hub. Lower TC mount is 3/8" stainless steel bolt with pipe spacer.
- Terminal cabinets for strain poles should have watertight compression fittings in bottom for control cable entrance, and bonding lug on outside.
- Label all terminals with mechanically printed labels.

CAUTION-POTENTIAL PROBLEMS

- Required number of terminal blocks varies, but should be distributed equally amongst the three lines.
- 2 spare terminal blocks required in all TCs.
- Do not bring bond wire into TC. Bond messenger cable to pole.
- Do not terminate Fire Pre-Emption or Illumination in terminal cabinet.

TERMINAL CABINETS

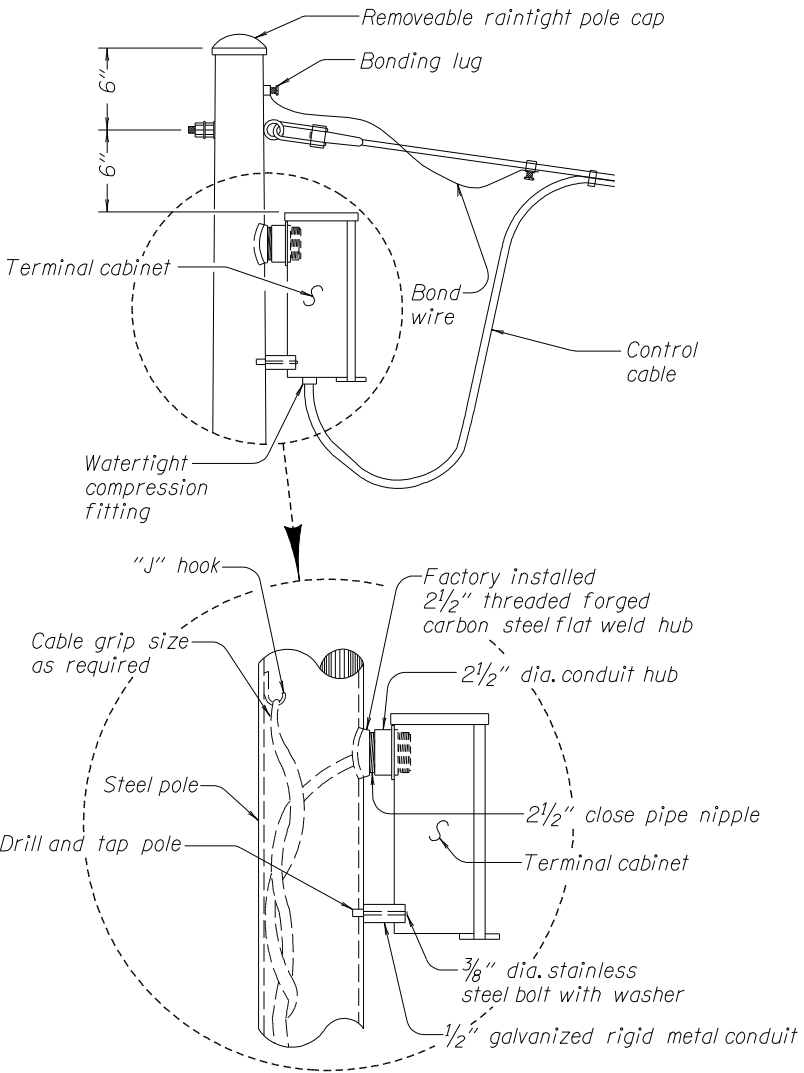

MESSENGER CABLE

Messenger cable is 3/8" galvanized 7-strand steel cable used to suspend equipment over the roadway.

- Rated at 11,500 lb break strength.
- Utilities grade cable.

PRIOR TO INSTALLATION

- Read 02920.22, TM452, TM453.
- Install 3/4" galvanized eyebolt as specified.
- Install strandwise bail onto eyebolt.

INSTALLATION

- Insert messenger cable into strandwise.
- Take up slack to minimum sag. (5% sag = 1.5' drop in 30' span).
- Trim off excess cable.
- One span per eyebolt.

CAUTION-POTENTIAL PROBLEMS

- Messenger cable does not use 'S' Hooks or turnbuckles.
- Bond messenger cable to pole.

MESSENGER CABLE AND ATTACHMENT

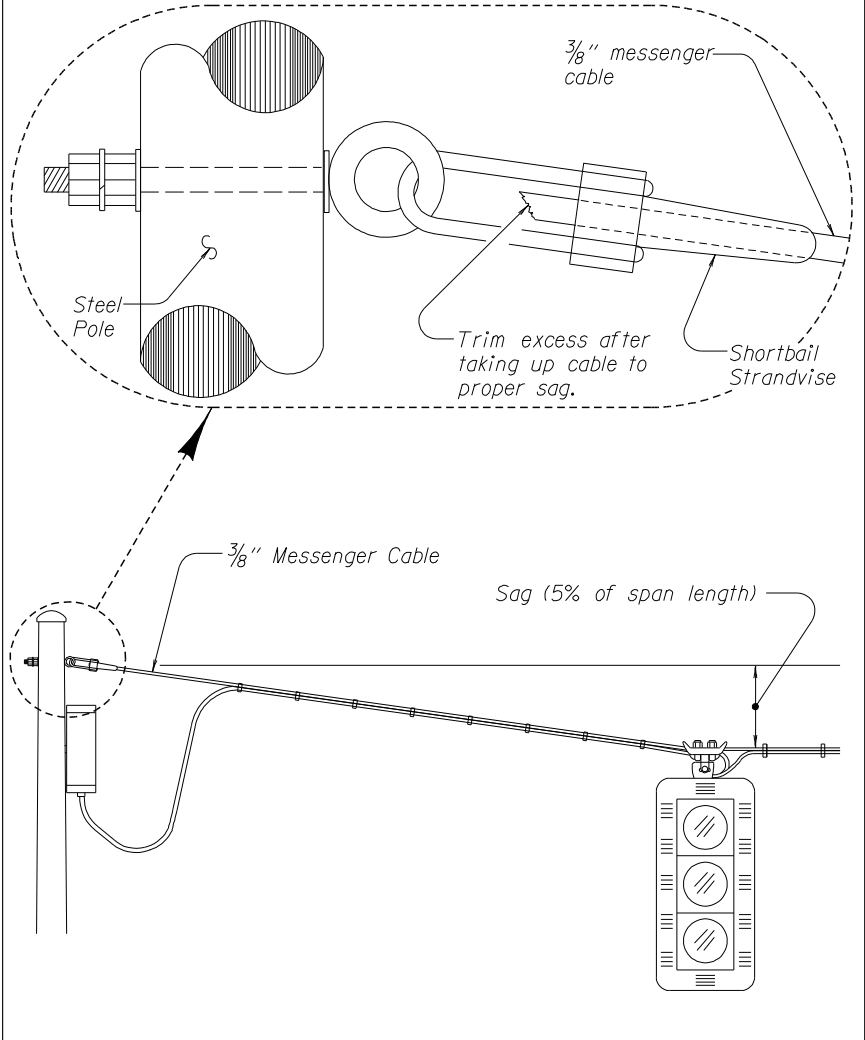

TETHER AND STABILIZER CABLE

Tether and stabilizer cable is ¼” galvanized steel cable used to prevent movement of equipment suspended from messenger cable.

- Common grade.
- Do not use high strength or larger cable. May not break when snagged.

PRIOR TO INSTALLATION

- Read 02920.22, TM452, TM453.
- Install 1/2” - 3/4” galvanized eyebolt as specified.
- Install 'S' hook onto eyebolt, turnbuckle onto 'S' hook, strandvise bail onto turnbuckle.
- 'S' hooks are State furnished by TSSU call 503-378-2956.

INSTALLATION

- Insert tether cable into strandvise and take up tension with turnbuckle.
- Trim excess cable.
- For stabilizer system see TM453.
- Close “S” hook on eyebolt side. (pole side only)

CAUTION-POTENTIAL PROBLEMS

- Tether & stabilizer cable requires the use of 'S' hooks and turnbuckles on both ends.
- See TM463 for tether clamp details (cable is installed below lock bolts and is wrapped in lead sheeting).

TETHER CABLE AND ATTACHMENT

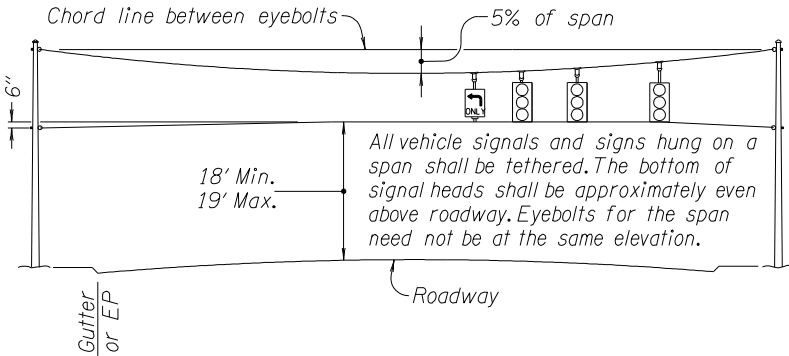
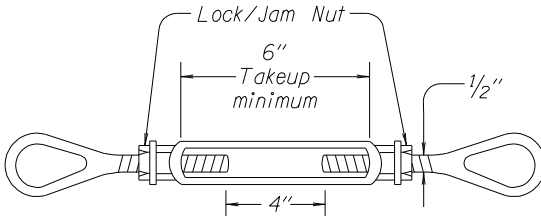
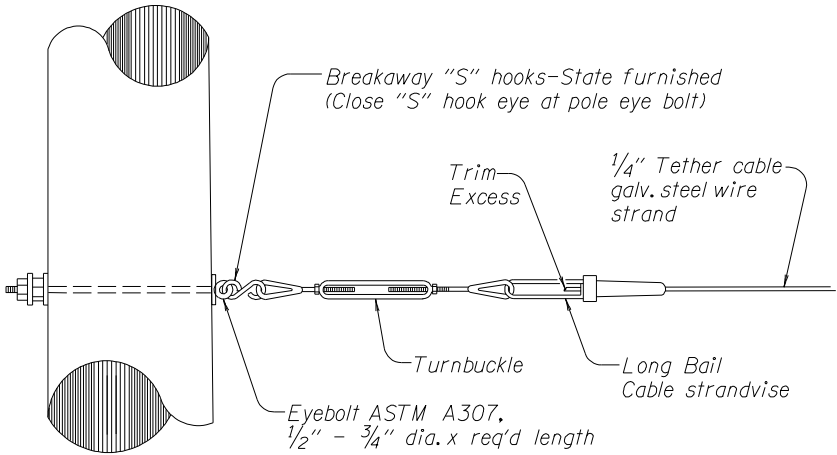

WIRING POLES

Wiring poles consists of single conductors brought into terminal cabinets via underground conduit, then distributed to various pieces of equipment. Some local jurisdictions use control cable in underground conduit.

- Signal heads normally use No. 14 AWG.
- Illumination on signal poles normally use AWG No. 10.
- Signal conductors are stranded copper, THWN wire.
- Illumination and power conductors are stranded copper, XHHW wire.

PRIOR TO INSTALLATION

- Read 00960.45, 00990.40, 02920.22, 02920.23, TM470.
- Verify 'J' hooks at terminal cabinet entrance to strain pole and at mast arm connection on mast poles.
- Become familiar with the color code and wiring from plans.

INSTALLATION

- Use cable grips to support wires or cables at "J" hooks (strain pole TC & mast arm connection).
- Wire mast arms with control cables (1-4 or 1-6 wire cable per vehicle head). Signal heads (same phase) on spans are wired individually.
- Span-wire control cables exit bottom of TC (using watertight compression fittings) and are attached to messenger cable with tie wraps every 6".

CAUTION-POTENTIAL PROBLEMS

- Observe color code.
- Install 3 spare conductors per plan if shown.
- Span-wire control cables can bypass TC. ie. fire preemption cable and power feed conductors
- Tape off ends of extra conductors.
- No splices are allowed – ANY WHERE
- Follow slack guideline (see 00990.40).

WIRING DETAILS

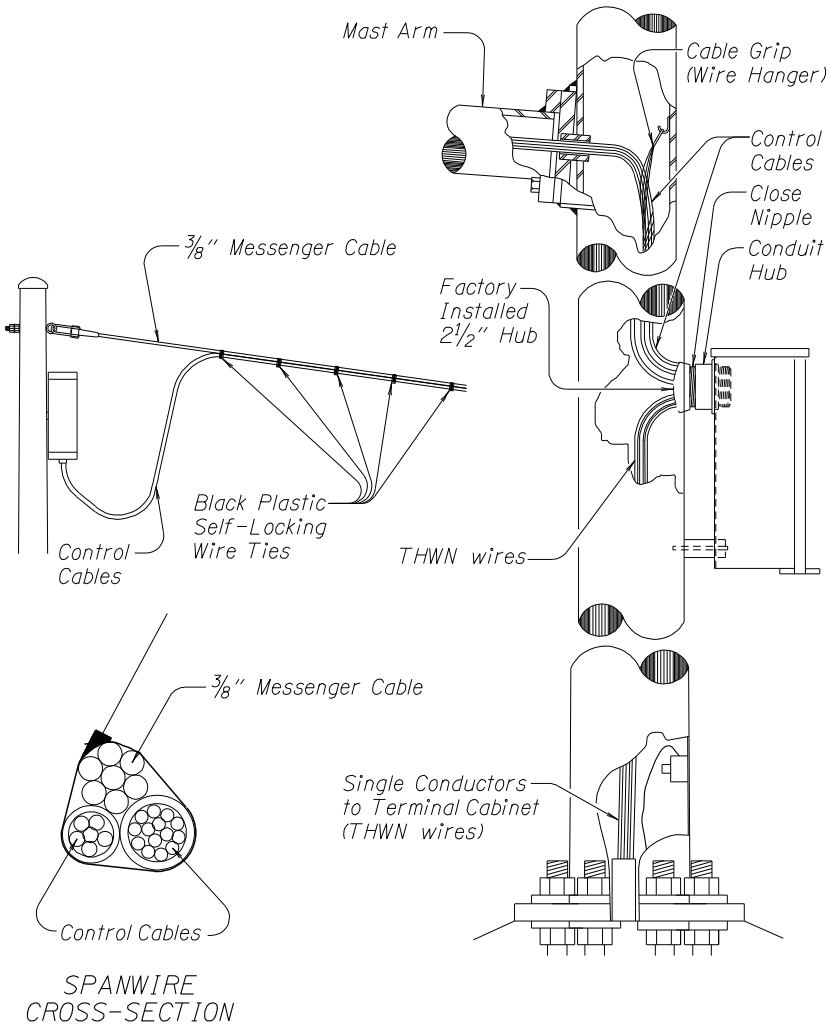

SPANWIRE HANGERS AND ADJ. BRACKETS

Spanwire hangers and adj. brackets are used to suspend equipment from messenger cables and mast arms. They also provide a cable entrance into the equipment.

- Spanwire hanger - Cast bronze.
- Adjustable brackets – Cast aluminum.

PRIOR TO INSTALLATION

- Install hardware with anti-seize compound.
- Read 02925.62 and TM462, TM463, and TM465.
- Check dimensions for specified head-to-travel lane relationship.
- Verify head/sign clearance for appropriate conduit length for spanwire hangers.

INSTALLATION

- Install hardware with anti-seize compound.
- Cable can be wrapped with sheet lead for tighter clamping.
- Extension shall be 1 ½” galvanized rigid conduit drilled and tapped to accept set-screw on hanger.

CAUTION-POTENTIAL PROBLEMS

- Bind control cable into a drip loop that is lower than the throat of the hanger.
- Control cable which bypasses must be arched over the hanger clamps to avoid damage.
- Span wire hangers use ‘U’ bolts for attachment, not ‘J’ or ‘L’ bolts.
- Adj. brackets require a safety cable.

SPAN WIRE HANGERS AND ADJUSTABLE BRACKETS

MESSENGER CABLE ATTACHMENT

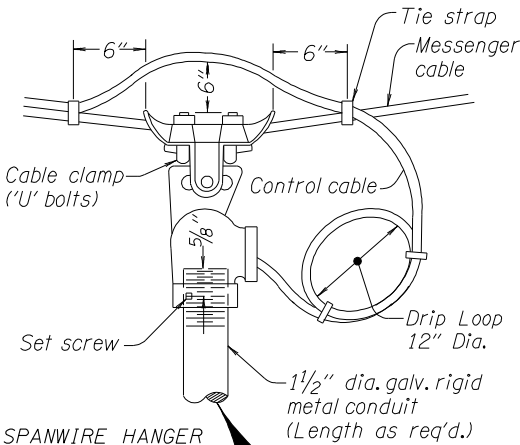

SPANWIRE HANGER

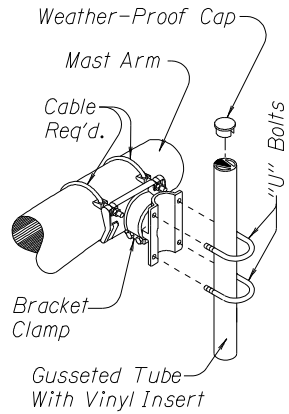

Silicone Seal

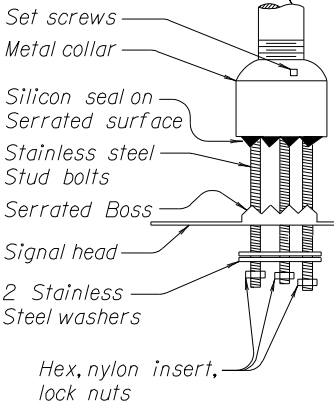

TRI-STUD ADAPTER

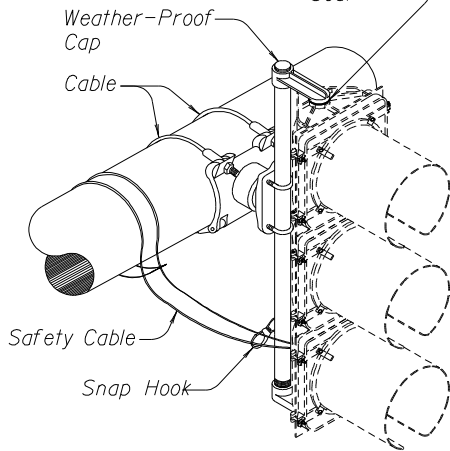

ADJUSTABLE BRACKET

PEDESTRIAN SIGNAL MOUNTS

Pedestrian signal mounts are clamshell type (standard).

- Hinged mounting brackets (clamshell mounts) are a two-piece, ready-to-use assembly into which the pedestrian signal is installed.

PRIOR TO INSTALLATION

- Read 02925.65, TM467.
- Drill pole for flange mount & ½” NF stainless steel, allen head, mounting bolts.
- Drill pedestal for set-screws on top mount.

INSTALLATION

- Mount terminal compartment and assemble.

CAUTION-POTENTIAL PROBLEMS

- Check visibility from far end of crosswalk, adjust as necessary.
- **PLUMBING PIPE AND FITTINGS** are not permitted.
- Clamshells must be mounted with the hinge at the rear of the pedestrian signal housing but may need to be reversed to allow for the opening of the ped. Head. Make sure that the ped. heads can be opened for maintenance.
- Make sure crosswalk lines up with ped. poles. (any pole with peds. on it)

PEDESTRIAN SIGNAL MOUNTS

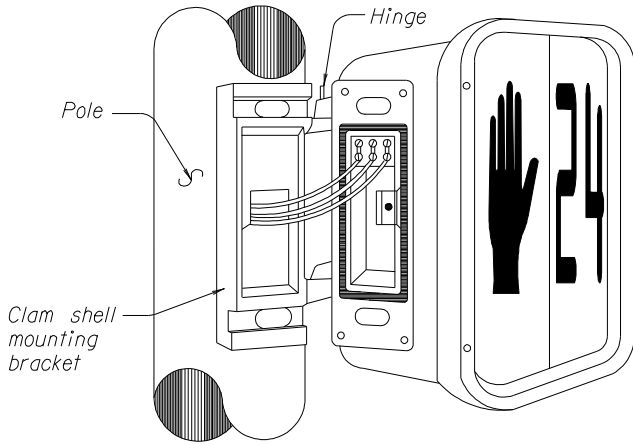

DETAIL VIEW
CLAMSHELL MOUNT
(Standard)

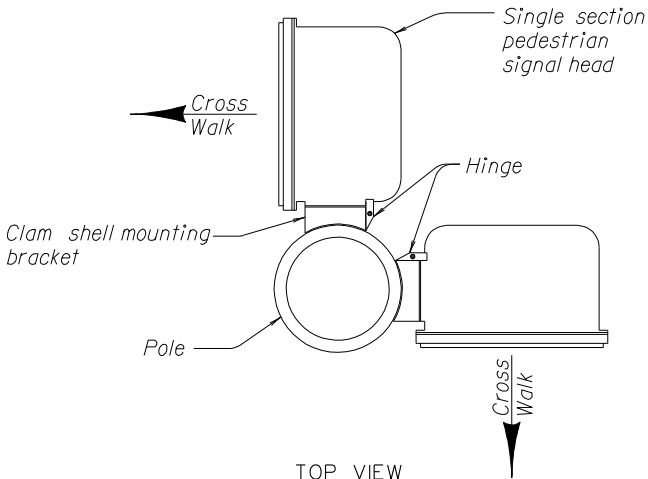

TOP VIEW
CLAMSHELL MOUNT

PEDESTRIAN SIGNALS & PUSH-BUTTONS

Pedestrian signals and push buttons are installed at crosswalks which do not have "CROSSWALK CLOSED" barricades or signs.

- Pedestrian signal heads consist of one section housing and use LED hand/man or LED countdown hand/man modules.
- Push-buttons are installed in a one-piece aluminum 'H' extrusion which includes the legend.
- Sign legend shall read "PUSH BUTTON FOR " , walking man symbol and include directional arrow when needed (see Pole Entrance Chart).
- Housing, doors and visors shall be powder coated aluminum or polycarbonate.

PRIOR TO INSTALLATION

- Read 00990.42(d), 00990.43(a), 002925.65, TM467.
- Verify that pole has been drilled at proper location (see Pole Entrance Chart).
- Verify direction of directional arrows on H frame.

INSTALLATION

- Bolt clam shell to pole, draw wiring from pole & connect to contact terminals.
- Bolt 'H' Frame to pole, draw wiring from pole & connect to contact terminals.

CAUTION-POTENTIAL PROBLEMS

- No fluorescent or neon lamps on pedestrian signals.
- Tamper-proof.

PEDESTRIAN SIGNALS & PUSH BUTTONS

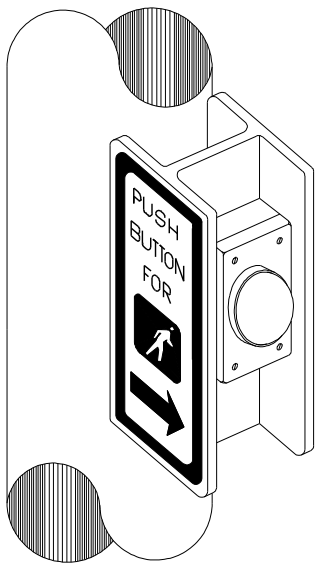
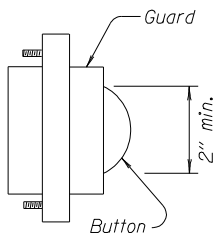

'H' FRAME WITH LEGEND
(Standard)

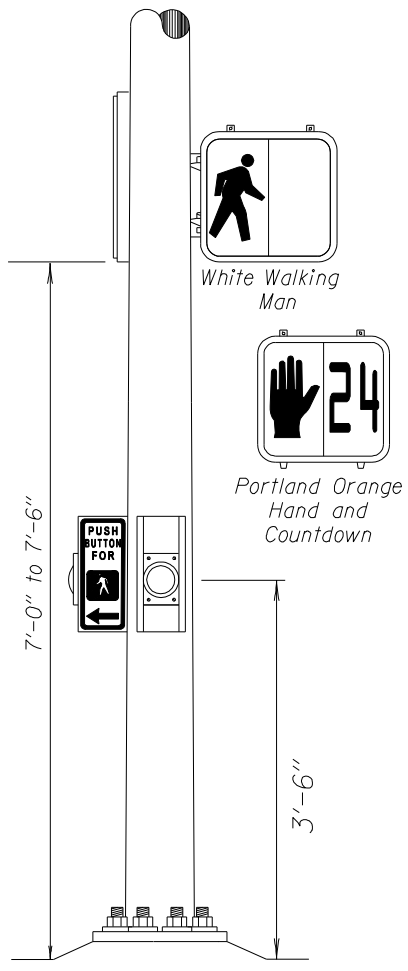

STANDARD VEHICLE SIGNALS

Standard vehicle signals are comprised of individual signal face sections configured to serve any particular intersection. All hardware and fasteners shall be stainless steel.

- Suspended from span wires with hangers, conduit nipples, and tri-stud adapters.
- Mounted to mast arms with adjustable brackets.
- Shall be aluminum powder coated 'flat black' or polycarbonate (head, visor, and backplate).
- Indications shall be LED. Refer to 00990.42 and 02920.51 for project specific requirements.
- Visors attach with stainless steel screws and washers.

PRIOR TO INSTALLATION

- See 00990.42, 02925.51, 002925.65, TM460, and TM462.
- Install hardware onto span wire, or install hardware onto signal head for mast arm/pole mounts.
- Install tether clamp hardware to bottom of signal for spanwire mount.

INSTALLATION

- Mount spanwire head to tri-stud using lock-nuts (or lock washers and Hex nuts), form control cable into drip loop, thread through hanger into signal head. Terminate wire and install tether.
- Mount adj. bracket on mast arm.
- Use anti-seize compound on all stainless steel fasteners.

CAUTION-POTENTIAL PROBLEMS

- All set-screws go through wall of conduit. With conduit extending 5/8" beyond set screw.
- Always seal tri-stud adapters with silicon seal.
- Adjust length of conduit nipple to achieve proper mounting height.
- Install back plates on all signal heads.
- Install tunnel visors unless plans specify another visor type.
- Cover signal heads until signal is activated.
- Install bottom hole plug.
- Drill 1/4" drain hole in bottom plug or case.

STANDARD VEHICLE SIGNALS

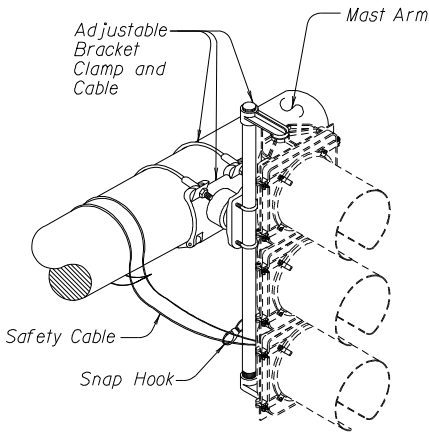
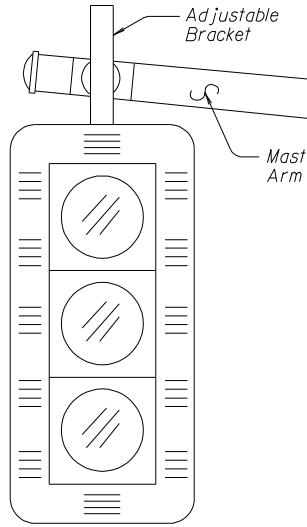
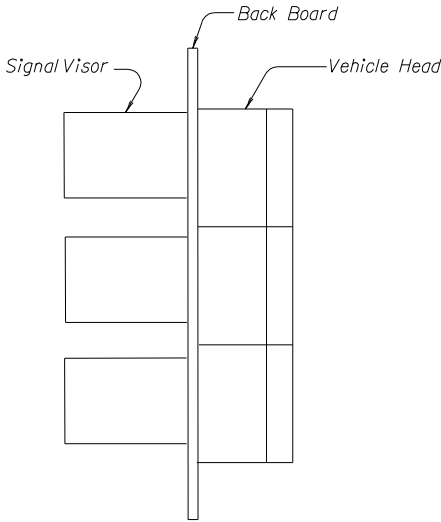

ADJUSTABLE BRACKET

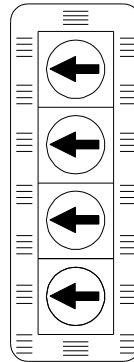

*Lens Arrangement "In Line"
Left Turn Protected /
Permitted To Be Mounted On
An Adjustable Bracket*

TYPE 6L
FLASHING YELLOW ARROW
ARRANGEMENT

PROGRAMMED SIGNAL HEADS

Programmed signal heads are designed to selectively limit the visibility zone. This may be necessary for acute approach angles, lane use, or special phasing.

- Special phasing or overlaps are the most common uses for programmed heads.
- Intersections that are too close together. (For restricted visibility from the other signal location)

PRIOR TO INSTALLATION

- Read 00990.42(c), TM450, TM460, TM462.
- Shim spanwire hanger so as to better restrict movement which could vary the visibility zone.

INSTALLATION

- Installation is essentially the same as for standard signal heads.
- Program (aka mask of portions of the lens) the head before placing the signal installation into operation.

CAUTION-POTENTIAL PROBLEMS

- Same as standard signal heads, except that programmed signal heads use cutaway visors.
- Standard signal heads may be used with geometrically programmed louver inserts into the visor.

PROGRAMMED SIGNAL HEADS

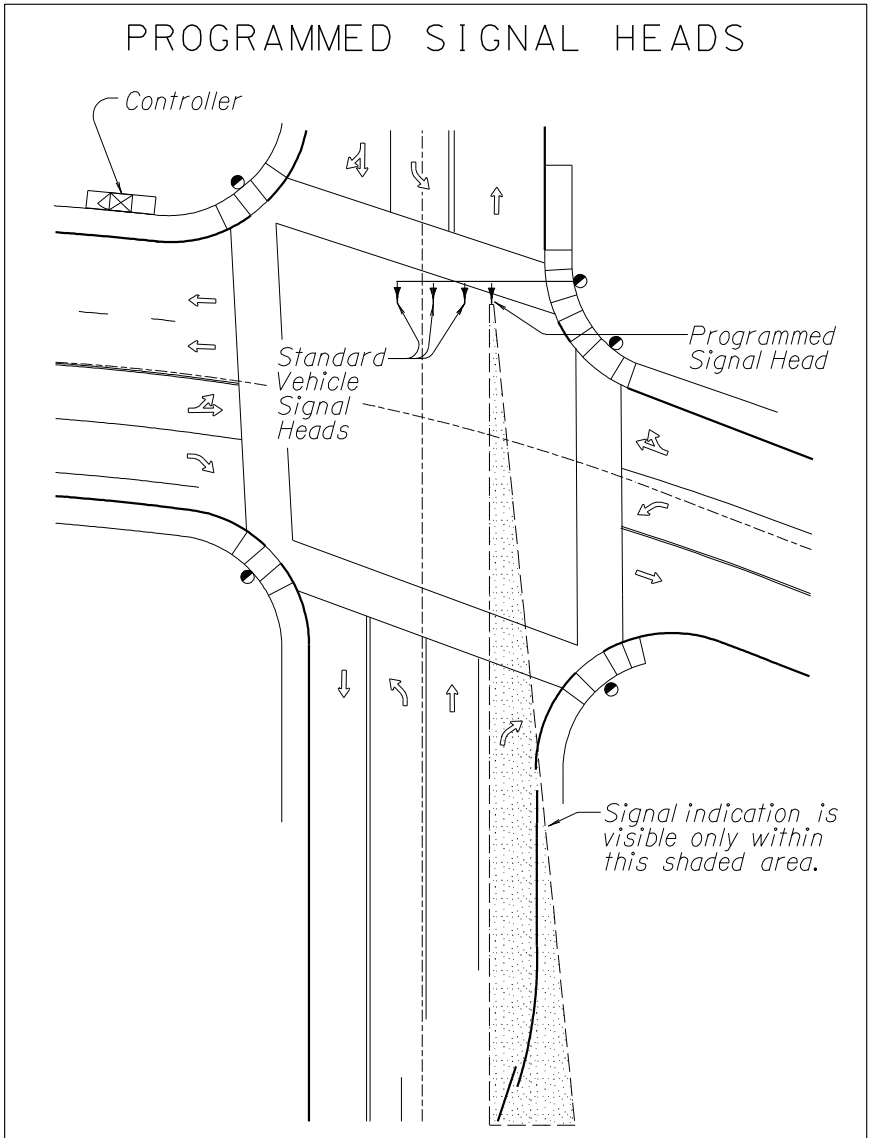

SAWCUTTING DETECTOR LOOPS

Sawcutting detector loops provides a trench into which the DUCTED XHHW loop wires are installed.

- Detector loop installations are the most failure-prone portion of a signal. Careful construction according to specifications greatly reduces this failure rate.
- Do not sawcut and seal NEW open graded mix, install in base lift AC.
- For EXISTING open graded mix, Consult Traffic Design for options. (Older AC, May install seal ½” low)

PRIOR TO INSTALLATION

- Read 00990.43(b), TM475.
- Mark out loop locations and loop wire returns.
- Loop wire returns cannot be routed through adjacent loops.
- Avoid sharp corners for loop wire returns. (Round off all corners, (NO MORE THAN 90° AT ANY ANGLE POINT)

INSTALLATION

- Sawcuts shall be at least ½” wide.(wider for loop returns)
- Sawcuts shall be deep enough to allow 2” cover over all wires placed in slot. (Deeper for old existing Open Graded Mix) Sawcut may be widened to accommodate multiple loop wire returns if pavement depth is inadequate.
- Flush sawcut with high pressure water stream before cuttings dry, blow out water and debris with high pressure/volume air, check the entire slot for any foreign debris, dry slot thoroughly with air or use vacuum/extractor system.
- Enter and exit round loops at approx. 90° angle.

CAUTION-POTENTIAL PROBLEMS

- Round corners to prevent insulation damage.
- Check thoroughly for rock shards in bottom of slot.
- Smooth edges of cuts into cast iron junction boxes or street boxes.
- Install PVC sleeve joint crossings as per TM475.
- Each loop must have loop wire return. Loops cannot be series'd in roadway.
- Loop wire returns are twisted 4-6 turns per foot.
- Pavement too thin to obtain cover, consult engineer of record for options.

SAWCUTTING DETECTOR LOOPS

DO NOT SAWCUT WEARING SURFACE OF OPEN GRADED MIX PAVEMENT, INSTALL LOOP IN BASE

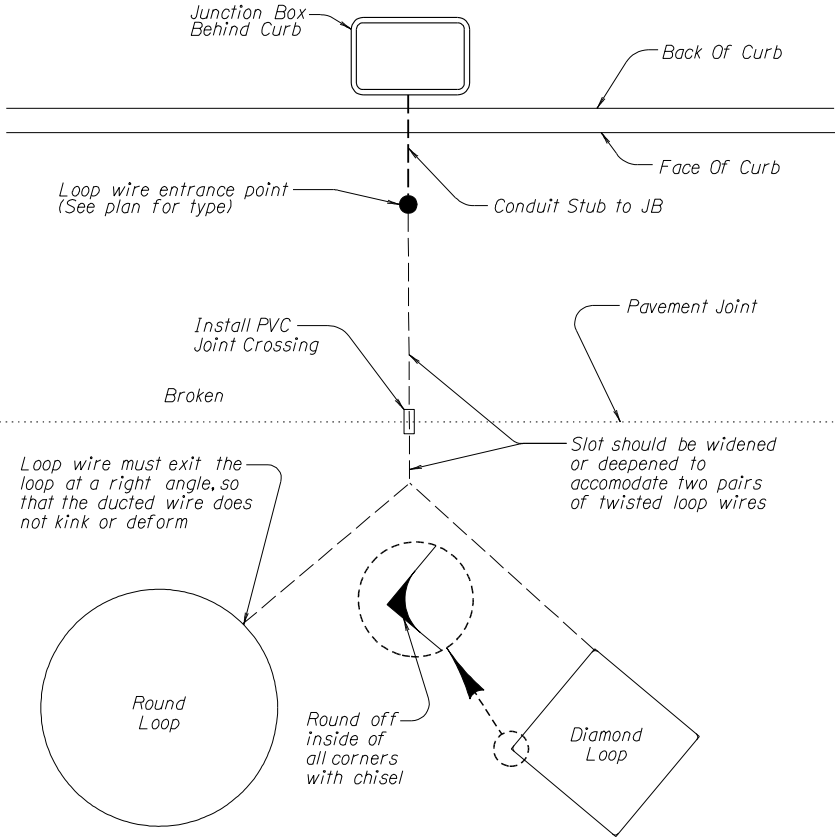

SAWCUT SLOTS FILLED WITH LOOP SEALANT, IN EXISTING OPEN GRADED PAVEMENT, MAY FORM WATER DAMS CAUSING PUDDLES OR ICE PATCHES. INSTALL SEALANT 1/2" BELOW EXISTING SURFACE TO MINIMIZE THIS EFFECT.

INSTALLING DETECTOR LOOP WIRES

Installing detector loop wires requires good practices and great care to avoid damage which is not readily apparent.

- Detector loops are failure-prone, loops may function initially, then fail months later when moisture intrudes through minor damage to the wire insulation.

PRIOR TO INSTALLATION

- Read 00990.43(b), TM475.
- Recheck slot for adequate width & depth.
- Recheck slot for foreign debris.

INSTALLATION

- Press loop wire into slot using a blunt, non-metallic tool. Do not force wire; The No. 14 AWG wire with duct should slip effortlessly into a 1/2" wide slot. If it doesn't, find out why, before duct or wire insulation is damaged.
- If two (or more) loops are to be installed in series, each pair of loop wires must return to the junction box before connecting loops in the series.
- Wedge 1" lengths of backer rod into all slots as loop wire hold-downs. Hold-downs should be placed no more than 12" apart and 6" from any corners.
- Test (megger) loops before placing loop sealant.

CAUTION-POTENTIAL PROBLEMS

- All loops are to be wound clockwise. (4 turns).
- Twisted pairs in a too-narrow slot can hang up requiring excess force to properly seat in bottom of slot.
- Avoid kinking or deforming ducted wire
- Wider slot required for loop returns, due to twisting and/ or multiple sets of ducted wires.

INSTALLING LOOP WIRES

Flush sawcut with high pressure water before rock dust dries, then blow out water and debris with high pressure/volume air or use vacuum extractor system. Dry slot thoroughly. Check for sharp rock shards.

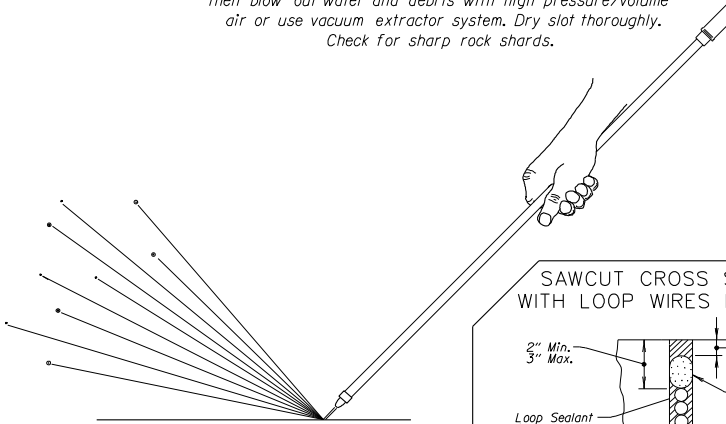

LOOPS SHALL NOT BE PLACED IN OPEN GRADED MIXES, THEY WILL NEED TO BE INSTALLED IN BASE LIFT.

SAWCUT CROSS SECTION WITH LOOP WIRES INSTALLED

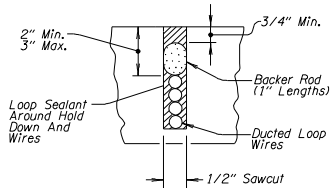

THIS DETAIL NOT FOR OPEN GRADED MIX

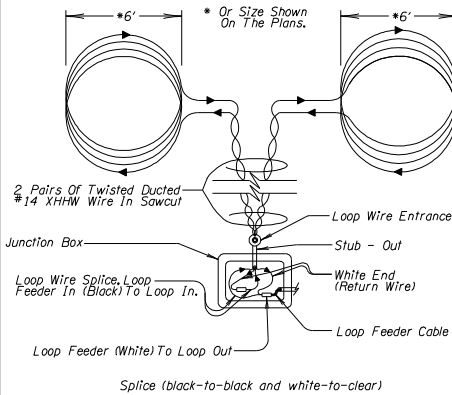

TWO LOOPS IN SERIES (TYPICAL WIRING DIAGRAM)

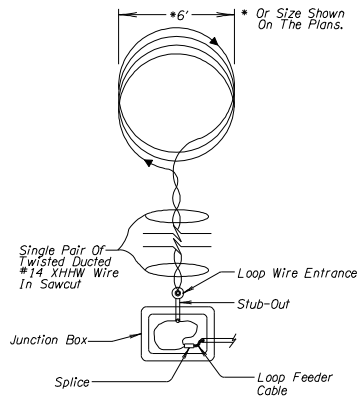

SINGLE LOOP

LOOP WIRE ENTRANCE

Loop wire entrance installations provide loop wire access to junction box conduit stubs.

- PVC CONDUIT OPTION-6” PVC conduit sleeve with AC cold mix cap/seal.
- SAND POCKET OPTION-6” max. opening cut into pavement, filled with sand and capped with AC cold mix.
- In the event of loop failure, the loop can be re-cut into these entrance points.

PRIOR TO INSTALLATION

- Read TM480.
- Use option, as called for, on plan sheets.
- Sawcut 6”x6” maximum opening or 4” diameter core drill opening for plan option.
- Take care not to damage conduit stub.

INSTALLATION

- Center conduit sleeve in hole and fill around box or sleeve with hard, non-flexible epoxy (not loop sealant).
- After epoxy cures, sawcut loop wire slots through epoxy and pvc sleeve.
- After installing wires, seal conduit with approved sealer, fill with sand and cap with cold mix AC.

CAUTION-POTENTIAL PROBLEMS

- Improperly sealed sawcut into sleeve or pocket may allow loop sealant migration into the conduit.
- Seal loop access points with cold mix AC, not loop sealant.

LOOP WIRE ENTRANCE INSTALLATIONS

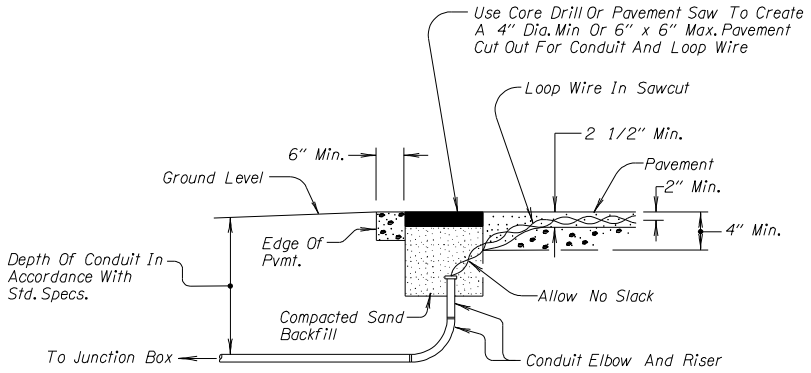

SAND POCKET OPTION

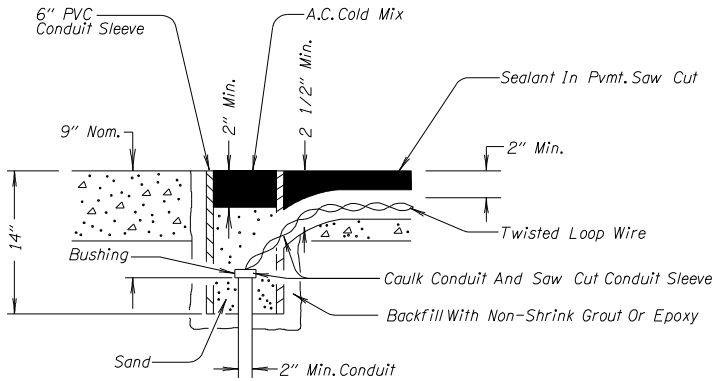

PVC CONDUIT OPTION

SEALING DETECTOR LOOPS

Sealing detector loops protects the loop wires from moisture and wear. Use only QPL listed sealants.

- Loop sealants shall be proportioned, mixed, and installed in accordance with manufacturer recommendations.

PRIOR TO INSTALLATION

- Read 00990.43(b), TM475.
- Test loop with 500 volt megger.
- Be sure backer rods are in place.
- Be sure end of sawslot at street box, sleeve or pocket (or cast iron junction box) is sealed with non-hardening compound.

INSTALLATION

- Place sealant directly into slot, using method recommended by manufacturer.
- High temperature sealants must be placed in lifts to avoid heat damage to insulation.
- Surface of sealant should be within 1/8" of pavement surface without protruding.
- Surface of sealant may be installed 1/2" low for old Open Graded Mix AC. (Consult Traffic Design for options)
- Retest loop after sealant is fully cured.

CAUTION-POTENTIAL PROBLEMS

- **DO NOT INSTALL** in wearing course of **NEW** open graded mix. Install in base course AC for new pavement.
- On sloped sections, duct tape can be used to contain sealant in sawslot. Remove tape after sealant is fully cured.
- If sealant runs or puddles on pavement surface, discontinue operation until contractor corrects his placement method.
- **DO NOT QUICK COOL SEALANT WITH WATER.**
- Maintain clean and **DRY** saw slot before sealing.
- **DO NOT** seal loops at temperatures below 40°F. (As per manufactures instructions)

SEALING DETECTOR LOOPS

Non-open graded AC pvmt.
0" - 1/8" down

Extg open graded AC pvmt.
1/2" - 5/8" down

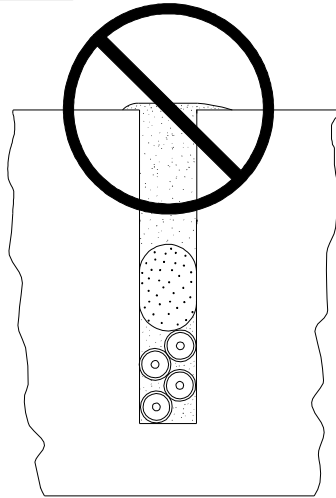
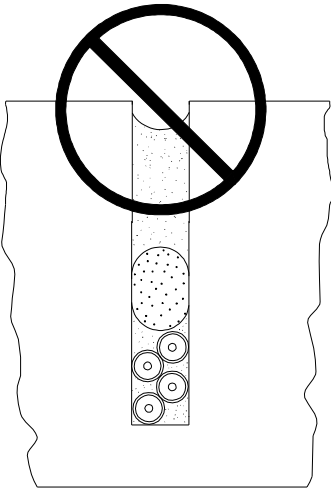
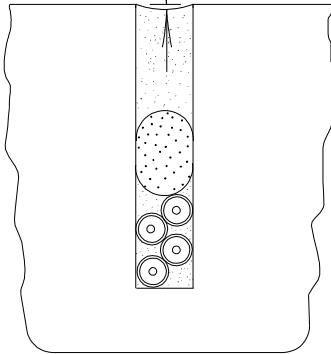

PREFORMED DETECTOR LOOPS

Preformed detector loops are to be used in thin pavement areas and concrete surfaces. They may be installed during the paving operation in the base lift of AC.

- We are now accepting a number of new systems; hydraulic hose, PVC conduit, etc. consult designer when new systems are called for by plans.
- Preformed loops are sealed systems from loop to junction box.

PRIOR TO INSTALLATION

- Read 00960.42, TM478.
- Mark out loop locations and loop return trench.
- Prepare surface in keeping with proposed loop system.

INSTALLATION

- Saw cut pavement for loop trench, clean & dress trench bottom & sides as for standard loop slots. Place preformed loop and return in trench and bed with sand to bottom of adjacent surfacing.
- Repave trench with material matching adjacent surfacing.

CAUTION-POTENTIAL PROBLEMS

- Preformed loops to be poured into bridge decks (or P.C.C. pavement) should be supported throughout at 2"-4" below finish grade. (See Bridge plans for further details.)
- All loops are wound clockwise, be sure the preformed loop is not installed upside-down (i.e. counter-clockwise).
- Meg Loops before backfilling.
- ALL preformed loops should be marked for direction wire is wound and IN and OUT wires.

PREFORMED DETECTOR LOOPS

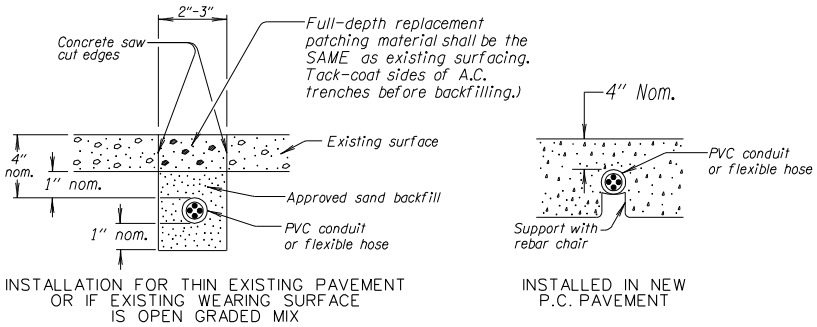
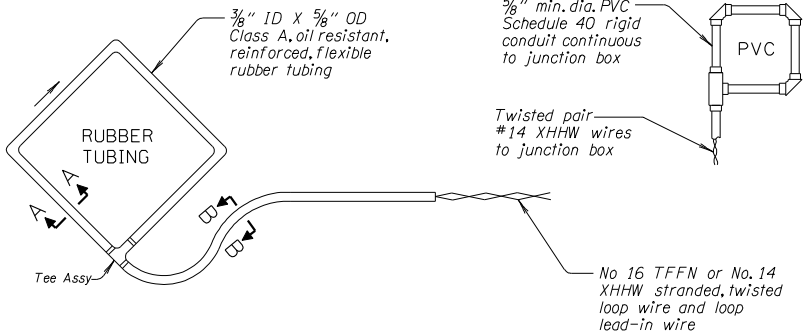

TYPICAL CROSS SECTIONS FOR FLEXIBLE PREFORMED LOOPS

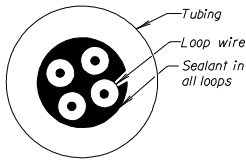

NOTE: Pave over installation has minimum cover requirement. See special provisions

FILLED LOOP
PAVE OVER OR SAWCUT
(FLEXIBLE HOSE)
SECTION A-A

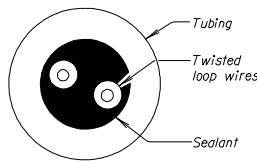

FILLED LEAD-IN
FOR PAVE OVER OR SAWCUT
(FLEXIBLE HOSE)
SECTION B-B

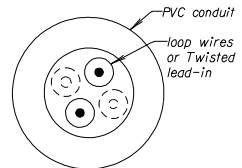

UNFILLED LOOP AND LEAD-IN
FOR PAVE OVER OR SAWCUT
(RIGID PVC LOOP)
SECTION B-B

LOOP WIRE SPLICES

Loop wire splices are made between pairs of loop wires and between loop wires and loop feeder cable.

- All splices for permanent installations must be made inside junction boxes not loop access.

PRIOR TO INSTALLATION

- Read 00990.43, TM475.
- Remove outer jacket of loop feeder, cut & remove drain wire and woven shield to 3" back of intended splice.
- Remove duct 3" back from splice.

INSTALLATION

- Remove insulation from conductors, install screw on silicon grease filled wire connector, install black plastic self locking straps, turn back wire connectors, insert into two piece plastic enclosure filled with silicon grease.
- Label loop feeder cables and loop wires with loop number. (both ends)

CAUTION-POTENTIAL PROBLEMS

- Do not ground shield or drain wire in J.B.

LOOP WIRE SPLICE

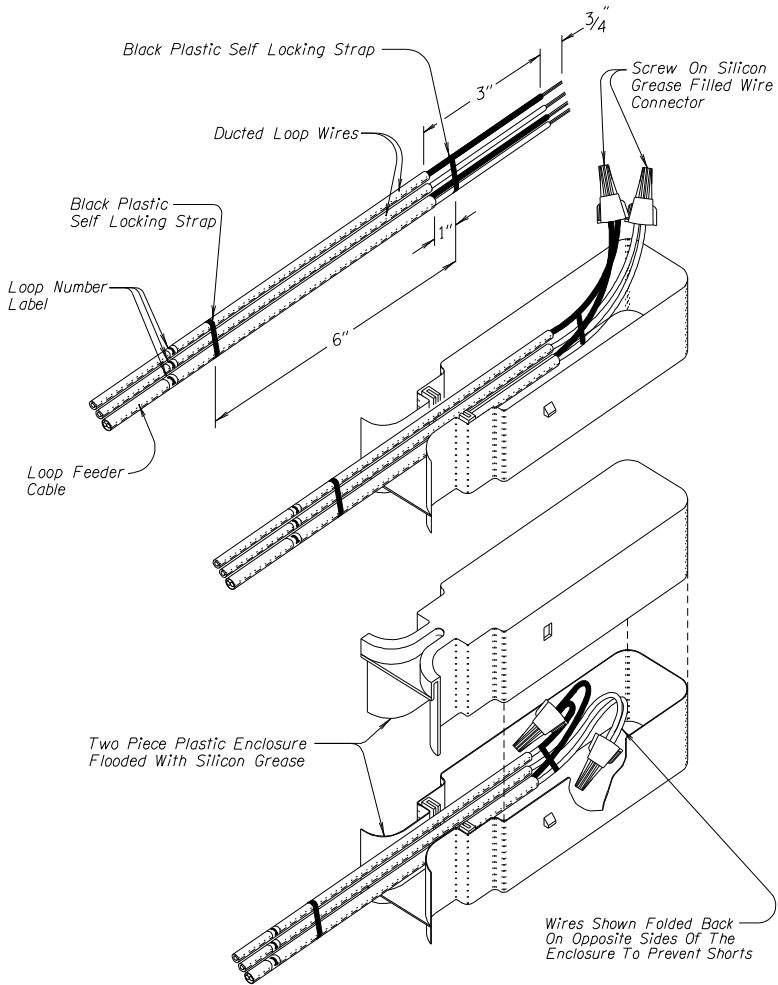

FIRE PREEMPTION SYSTEMS

Fire preemption systems are installed at some intersections.

- Fire preemption detectors are installed as part of the signal system.
- Fire department vehicles with the proper light emitters can disrupt normal phasing to provide a green light for their direction of travel. Normal phasing resumes after the fire vehicle crosses the intersection.
- Some systems may include a priority for other than emergency vehicles.

PRIOR TO INSTALLATION

- Read 00990.46, TM465.
- Examine physical layout of intersection to ensure proper placement of detectors. Change placement if necessary to provide an uninterrupted line-of-sight for 1000' of approaching lane.
- Extremely curvy approach to intersection may require the placement of a remote fire preemption detector unit.

INSTALLATION

- Mount detector unit using appropriate method dependent upon placement.
- Connect detector unit to controller with single, unspliced length of preemption detector feeder cable.

CAUTION-POTENTIAL PROBLEMS

- Remember to knock out appropriate weep hole.
- Pole mounted detector units must be mounted at least 19' above roadway surface.
- One-way detectors may have two input tubes. Aim both at 1000' approach point.
- Cable is never spliced and bypasses terminal cabinets

TYPICAL MOUNTING DETAILS FOR FIRE PREEMPTION DETECTOR UNIT

Use U-bolt clamp when detector is hung upside down from span wire

Detector cable

12" Drip loop

Before mounting, apply waterproof tape to threads as directed by manufacturer

NOTE:
Knock out weep hole before installing

SPAN WIRE INSTALLATION

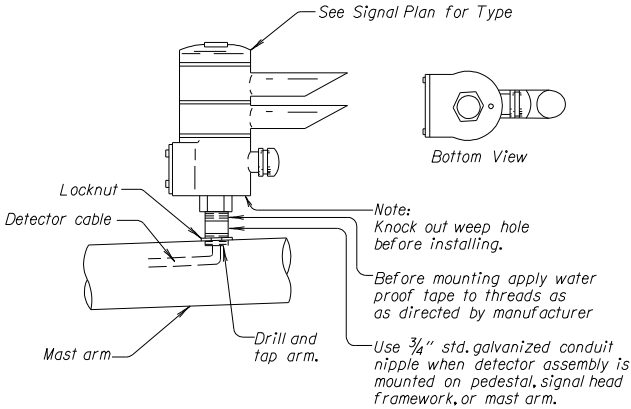

MAST ARM MOUNTING

LUMINAIRES

Luminaires are often included in traffic signal installations.

- Poles with luminaire extensions will have an 'L' suffix and will include the luminaire mounting height in the legend.
- Plans specify luminaire arm length and luminaire type, and wattage.

PRIOR TO INSTALLATION

- Read 00970, TM650, TM660, TM465.
- Locate and verify pole position.
- Wiring for illumination is not routed through the controller.
- Service cabinets for signals with illumination normally include a test switch.
- Mount photoelectric cell as per 00970.43. (20'-36' up pole).

INSTALLATION

- Luminaires must be installed level.
- If roadway profile grade is greater than 4 percent, rotate luminaire on arm so side-to-side so position of leveling pad is parallel with roadway grade.
- Attach lamp target to luminaire or arm.
- Mark lamp base with month & year installed.
- Support conductors with cable grip at top of pole.
- Some local agencies use a photocell on each luminaire rather a system photocell.

CAUTION-POTENTIAL PROBLEMS

- If a pole location is changed more than 6' laterally or 3' perpendicular, consult ENGINEER OF RECORD. Luminaire or arm length may need to be changed.

INSTALLING LUMINAIRES

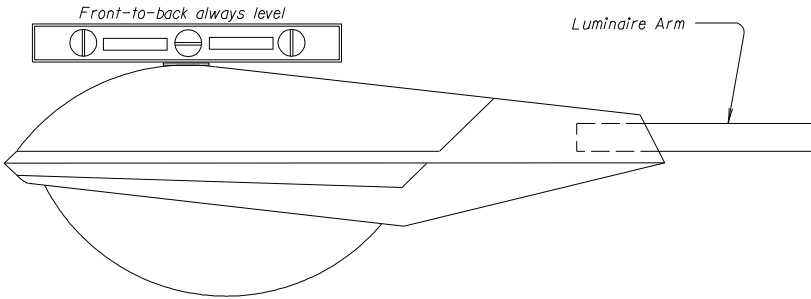

SIDE VIEW

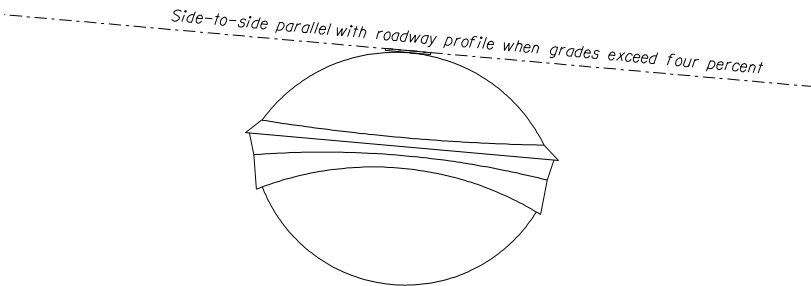

FRONT VIEW

SERVICE CABINETS

Service cabinets are Base Mounted Service (BMC) cabinets.

- Power to permanent signals typically is underground, up into BMC cabinet.

PRIOR TO INSTALLATION

- Read 00960.49, 00990.41, 02925.40, and TM485.
- Locate service in a safe and protected area.

INSTALLATION

- Wire power service out to controller in separate conduit.
- Do not wire illumination circuit through controller cabinet.
- Install 2 ground rods 6' minimum apart in JB/1's, with pvc conduit between JB's and RPS or BMC.

CAUTION-POTENTIAL PROBLEMS

- Check with local power company for meter base mounting height.
- Contractor obtains the required permits and arranges for utility to inspect power service.
- Project Manager arranges for electrical hookup.
- NEVER mount service equipment on controller cabinets.
- Check service cabinet for damage to galvanizing and/or powder coating, repair as needed.
- Check meter base for damage to powder coating, repair or replace cabinet if damaged coating can not be repaired.

BASE MOUNTED SERVICE CABINETS

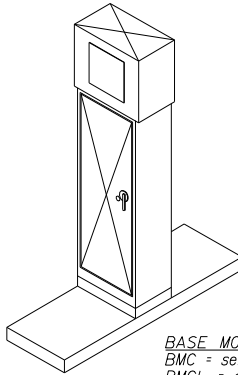

BASE MOUNTED SERVICE OPTIONS
 BMC = service for signal system
 BMCL = service for signal and illumination
 BMCF = service for flashing beacon system

BASE MOUNTED SERVICE (STANDARD)

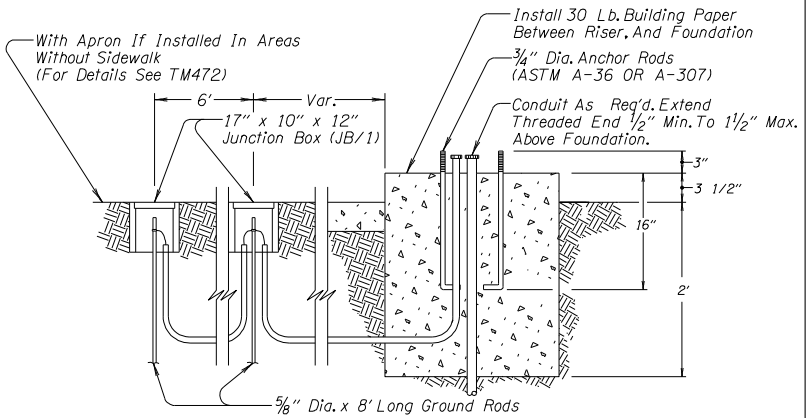

BASE MOUNTED SERVICE & CONTROL CABINET FOUNDATION

MODEL 332 CONTROLLER CABINETS

Model 332 controller cabinets are specified for most signal installations.

- All traffic signal control equipment must be submitted for physical, functional, and environmental testing.
- After testing, the control cabinet will be released to the contractor for installation.
- The TSSU will deliver and install all internal control equipment.

PRIOR TO INSTALLATION

- Read 00990.70, 02925.40, TM482.
- Install riser frame to new foundation. Adapter plates or bolted riser frames may be used to install cabinets onto existing foundations.
- Verify ground rod is in place.

INSTALLATION

- Install building paper gasket between riser frame and foundation. Install non-hardening water-tight seal between riser frame and controller cabinet.
- Bond all conduits together and ground to the lug inside the cabinet.

CAUTION-POTENTIAL PROBLEMS

- Ground rod may be installed inside controller cabinet in conduit area.
- Slack wire coiled neatly in bottom of cabinet.
- Locate controller in protected area, behind pole and away from traffic.
- Protect controller with metal pole barrier, from automobile damage near parking lots.

332 CONTROLLER CABINET FOUNDATION

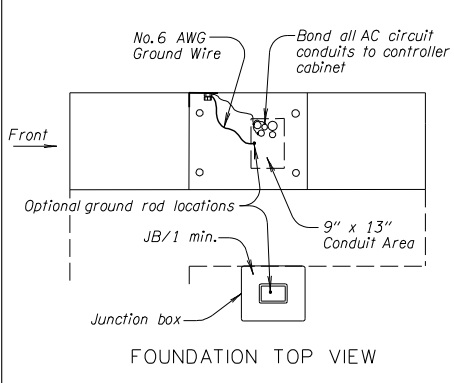
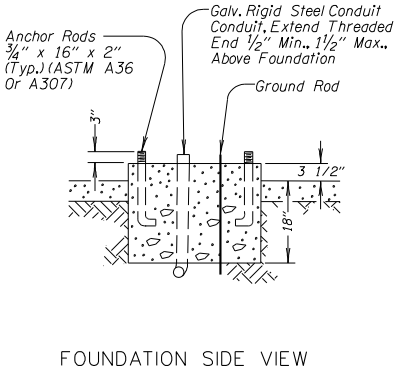
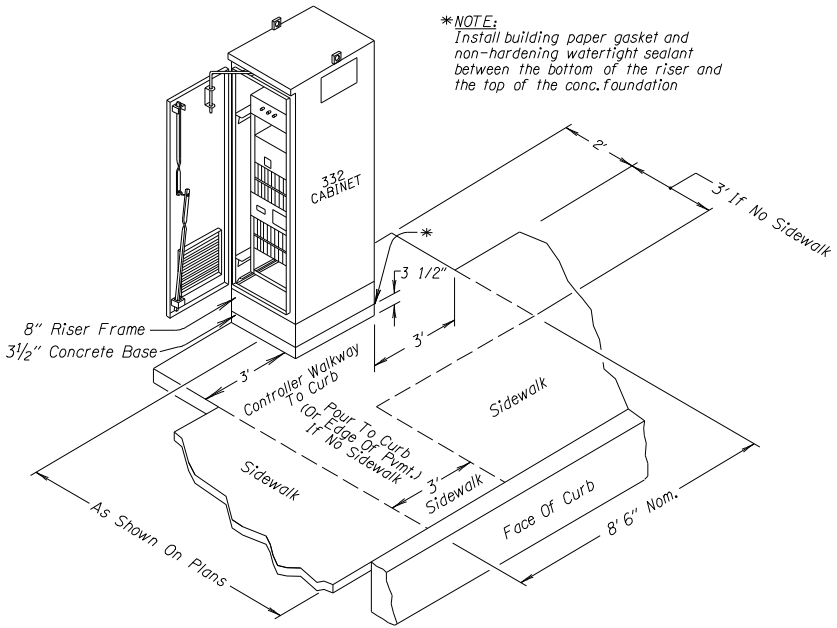

MODEL 336 CONTROLLER CABINETS

Model 336 controller cabinets are pole mounted for signal installations needing minimal inputs and outputs, or for downtown city installations with sidewalk clutter limitations.

- All traffic signal control equipment must be submitted for physical, functional and environmental testing.
- After testing, the control cabinet will be released to the contractor for installation.
- The TSSU will deliver and install all internal control equipment.

PRIOR TO INSTALLATION

- Read 00990.70 & 02925.40.
- Check welding of galvanized 3" to 2½" reducer bushing in pole, install conduit nipple.
- Install 'LB' conduit fitting onto nipple, and close couple nipple onto 'LB' fitting.
- Check to see that cabinet bottom is solid.

INSTALLATION

- Install cabinet onto close couple nipple.
- Mount cabinet onto pole with Nom. ¾" wide galvanized steel or stainless steel bands.
- Ground is provided through mechanical attachment to pole.

CAUTION-POTENTIAL PROBLEMS

- Intake vent must be screened and cooling fan operational for controller to function properly.
- Maintain access to cabinet when used at a temporary signal installation
- DO NOT locate controller cabinet on back of pole in path of pedestrians. Locate on side of pole away from traffic.

WOOD POLE MOUNTED CONTROLLER CABINET

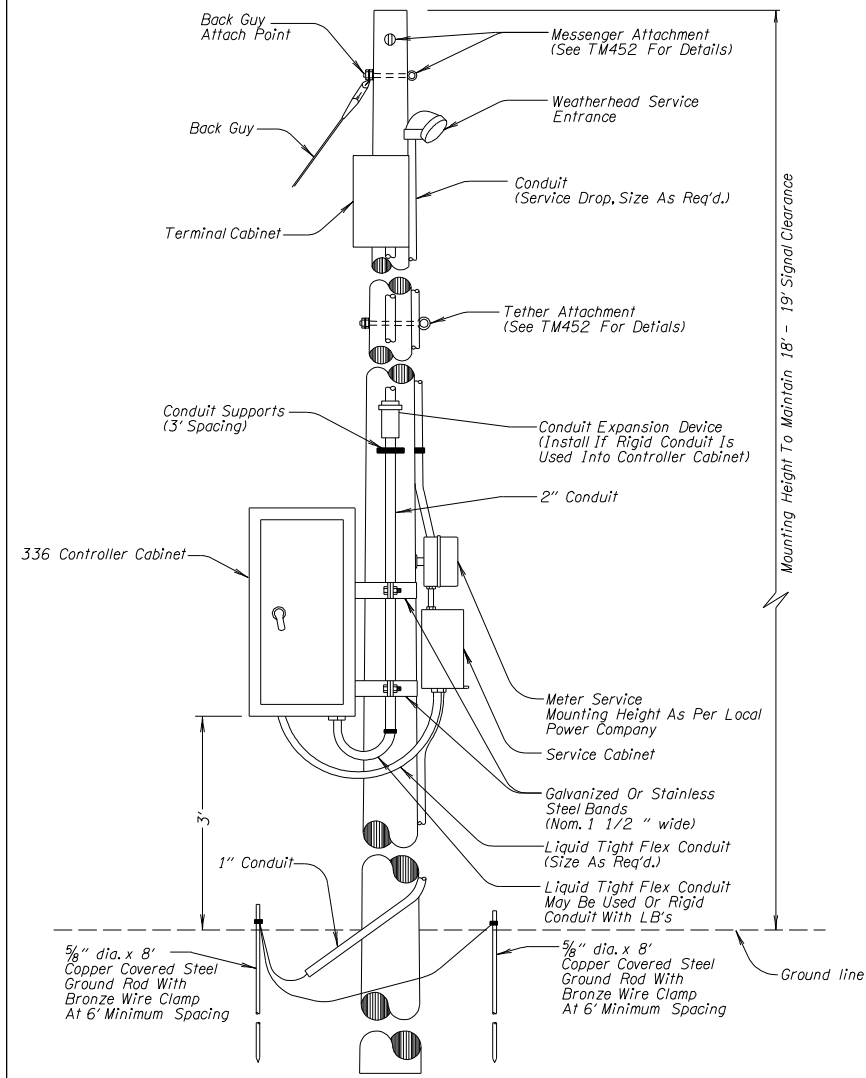

FIELD INSPECTION & SIGNAL TURN-ON

The Project Manager (in conjunction with Agency Electricians and Region Traffic Staff) establishes the date and time of the signal turn-on when the contractor notifies the Inspector/Project Manager of their estimated completion date. The Agency Electricians will also schedule a Field Inspection to take place prior to the signal turn-on date.

After traffic signals are turned on and operating as designed (or in some cases upon project completion), the agency ultimately responsible for maintenance will assume operation and maintenance of the signal. The Contractor then starts the warranty period for their workmanship on the project.

TURN-ON DOES NOT CONSTITUTE FINAL APPROVAL.

FIELD INSPECTION & SIGNAL TURN-ON (CONT.)

PRIOR TO TURN-ON

- Read 00990.70
- Coordinate with Region Traffic, Agency Electricians and Contractor when establishing the Field Inspection and Turn-on schedule.
- Ensure the Contractor completes the “punch list” items provided by the Agency Electrician’s Field Inspection prior to the Turn-on date.

DAY OF TURN-ON

- Contractor is required to present during the signal turn-on to un-bag signal heads and allow for quick correction of any problems encountered.
- Flaggers and associated TP&DT should be on-site and ready. Turning-on a new signal can typically be done safely without flaggers, but turning-on a re-built signal always requires flaggers.

CAUTION-POTENTIAL PROBLEMS

- **NO SIGNAL TURN-ON’S ON FRIDAYS OR THE DAY BEFORE A HOLIDAY.**
- Note the required advance notice timeframes – good communication is essential to keep the turn-on date on schedule, especially if problems arise.
- Ensure that all striping (either temporary or permanent) is in place, such as stop bars, crosswalks, lane lines, and lane use arrows. Striping may be installed up to two weeks prior to scheduled signal turn-on date.
- Ensure that all necessary signing (either temporary or permanent) is in place, such as “signal ahead” signs, lane use signs, etc.
- Ensure that any inappropriate/conflicting signing (STOP signs, “stop ahead” signs) or striping is promptly removed or covered up as per the Standard Specifications.

FINAL CLEAN-UP & FINAL INSPECTION

When the signals on the project have been successfully turned-on and all work (including punch list items) and clean-up has been satisfactorily completed, the project is ready for final inspection.

When, in the opinion of the Project Inspector and agency electricians, the Contractor has fulfilled all requirements of the contract, he must notify the Project Manager and the agency who will assume maintenance responsibility that the project is ready for the Final Inspection. The party responsible for maintenance and the Project Manager should review the project together so that the permitting agencies Electrical Inspector can sign off on the project. Upon acceptance, the Contractor is notified and relieved of responsibility. At the same time, the agency designated to assume responsibility for the maintenance of the signal should be notified in writing. This notification should include the specific date and time of the maintenance responsibility transfer. For ODOT, Traffic Signal Services Unit should also be notified of this date.

On some projects, the special provisions may provide for the acceptance and transfer of maintenance when the signal is turned on.

Upon completion of the work installing the traffic signal, and before acceptance of the project, the Contractor must clean and remove all rubbish and equipment on the highway right-of-way which is a result of the contract work.

The Contractor must also remove all excess excavated material resulting from the construction of boring pits, pole foundations, conduit trenches, or any other excavation required to complete the project. All materials removed must be disposed of at an approved location. Disposing of these materials on property adjacent to the highway will not be considered acceptable unless approved by the Project Manager. All excavations should be finished to the existing contours of the ground-line surrounding the work area. All landscaping and underground utility systems disturbed by the Contractor shall be returned to original condition by the Contractor at his expense.

AS CONSTRUCTED DRAWINGS

Once the signal installation has been accepted, as constructed (red line, not modified CADD) drawings will need to be made and sent in with the semi-final records. ANY part of the installation of the traffic signal that differs from the original design needs to be noted so that others will have accurate information as to how it was built.

Especially important to note are changes in:

- location of junction boxes
- vehicle signal heads
- conduit runs
- wiring
- pole locations
- Utilities

The changes noted on the drawings need to be detailed/complete enough to accurately amend the original plans. The as constructed drawings you submit will be reviewed by the Traffic-Roadway Section and the final mylars will be altered to reflect construction changes.

Traffic Roadway Section will send copies of the final mylars to the appropriate region and district offices and electrical crew for their records. They rely on the drawings to be accurate and to aid them in the maintenance of the traffic signals and illumination.